

243054

JPRS-CST-88-012

12 JULY 1988



**FOREIGN  
BROADCAST  
INFORMATION  
SERVICE**

# ***JPRS Report***

# **Science & Technology**

***China***

DTEC QUALITY INSPECTED 2

19981125 136

REPRODUCED BY  
NATIONAL TECHNICAL  
INFORMATION SERVICE  
U.S. DEPARTMENT OF COMMERCE  
SPRINGFIELD, VA. 22161

10  
133  
A07

12 JULY 1988

SCIENCE & TECHNOLOGY

CHINA

CONTENTS

SCIENCE & TECHNOLOGY POLICY

Wuxi To Become Southern 'Silicon Valley'; Establishment of Microelectronics Base Speeded Up (RENMIN RIBAO, 28 Mar 88) .....	1
Technology Exports Expand (JISHU SHICHANG BAO, 27 Jan 88) .....	2
FRG's AEG To Set Up Training Centers (JISHU SHICHANG BAO, 6 Feb 88) .....	3
Digital Switchboard Agreement With Philips (DIANZI SHICHANG, 25 Feb 88) .....	4

AEROSPACE

Major Institutes' Role in Nation's Space Effort Outlined (Chen Daming; HANGTIAN, No 2, 26 Mar 88) .....	5
Theoretical Investigation of Separated Vortex Motion, Vortex Breakdown Feature (Lin Bingqiu; KONGQIDONGLIXUE XUEBAO, No 1, Mar 88) .....	10
Viscous/Inviscid Interaction Algorithm To Analyze Transonic Airfoil Flows With Separation (Zhang Huiliu, et al.; KONGQIDONGLIXUE XUEBAO, No 1, Mar 88) .....	11

Calculation of Ground Effect on Flow About Airfoil With Rear Separation (Jiang Linbo, et al.; KONGQIDONGLIXUE XUEBAO, No 1, Mar 88) .....	12
Vortex System, Pressure Distribution of Slender Bodies With Elliptical Cross Section Nose at High Angle of Attack (Xiong Shanwen, et al.; KONGQIDONGLIXUE XUEBAO, No 1, Mar 88) .....	13
Formation Mechanism of Asymmetric Spatial Vortex of Slender Bodies at High Angle of Attack (Wang Zixing, Su Dai; KONGQIDONGLIXUE XUEBAO, No 1, Mar 88) .....	14
Aerodynamic Characteristics of Vortex Flap, Combination With Apex Flap (Zhuang Fenggan, et al.; KONGQIDONGLIXUE XUEBAO, No 1, Mar 88) .....	15
Experimental Investigation of Formation Mechanism of Effect of Spin Nose to Asymmetric Vortices on Slender Body at High Angle of Attack (Su Dai, Wang Zixing; KONGQIDONGLIXUE XUEBAO, No 1, Mar 88) .....	16
Experimental Investigation of Formation, Decay of Vortex Under Interaction of Jet With Crossflow (Sheng Chunhua, et al.; KONGQIDONGLIXUE XUEBAO, No 1, Mar 88) .....	17
Vortex Interaction of Two Wing-Body Missile Configurations (Feng Yanan, et al.; KONGQIDONGLIXUE XUEBAO, No 1, Mar 88)	18
Characteristics of Asymmetric Vortices, Methods To Alleviate Off-Plane Forces, Moments (Zeng Guangcun, et al.; KONGQIDONGLIXUE XUEBAO, No 1, Mar 88) .....	19
Shanghai Develops Launch Vehicle for Nation's First Weather Satellite (JIEFANG RIBAO, 3 Apr 88) .....	20
Simulation Facility Has Major Role in Manned Space Program (RENMIN RIBAO, 20 Apr 88) .....	21
Medium-Wave Navigation Units (DIANZI SHICHANG, 4 Feb 88) .....	24

ADVANCED MATERIALS

Measurement of Infrared Optical Constant Dispersion Curves of Free-Standing Thin Polyester Film by Kramers-Kronig Relationship (Wang Yongtai, et al.; HONGWAI YANJIU, No 1, Feb 88) ....	25
Polarity Study of Rubidium Acid Phthalate (RAP) Single Crystals (Shi Zikang, et al.; HONGWAI YANJIU, No 1, Feb 88) .....	26
Parallel Digitized Interferometer Proposed (Wang Zhaoshen, et al.; HONGWAI YANJIU, No 1, Feb 88) ...	27
Studies on Diffusion Process of Fissioning Nuclear System.* I. Analysis of Process Approaching Equilibration (Feng Renfa, et al.; YUANZIHE WULI, No 1, Feb 88) .....	28
Study of ( $\alpha$ , p) Three Nucleon Transfer Reactions of Odd a Nuclei in $1f_{1/2}$ Shell (Yuan Rongfang, et al.; YUANZIHE WULI, No 1, Feb 88) ....	29
Small Angle, Total Elastic Scattering Cross Sections of Fast Neutrons (Li Jingde, et al.; YUANZIHE WULI, No 1, Feb 88) .....	30
Theoretical Analysis of Effects of Misalignments in Nonlinear Beam Transport System (Liu Chunliang, et al.; YUANZIHE WULI, No 1, Feb 88) ....	31
Electron Stripping Cross Section of Ions by Atoms (Zhang Xixiang, et al.; YUANZIHE WULI, No 1, Feb 88) ....	32
Study of Wear Resistance of Steel Samples Implanted With $N^+$ Ions or Nitrided (Wang Tianmin, et al.; HE JISHU, No 3, Mar 88) .....	33
Influence of Ion Implantation on Friction Properties of Soft Metal Materials (Hu Zhengqiong, et al.; HE JISHU, No 3, Mar 88) .....	34
Improvement of Oxidation Resistance of Steel Samples by Ion Beam Mixing (Liu Xianghuai, et al.; HE JISHU, No 3, Mar 88) .....	35
Effects of Implantation With N, B, Cr, Mo Ions on Corrosion Behavior, Microhardness of Pure Iron Samples (Lu Haolin, et al.; HE JISHU, No 3, Mar 88) .....	36

Effects of Ion Implantation on Performance of Electric Contacts (Xu Shiru, et al.; HE JISHU, No 3, Mar 88) .....	37
Surface Modification of Aero-Bearing (Wang Yirong, et al.; HE JISHU, No 3, Mar 88) .....	38
Anodic Polarization of Hard Aluminum: Influence of Ion Beam Twice Mixing on Corrosion Behavior (Wang Peilu, et al.; HE JISHU, No 3, Mar 88) .....	39
Nitrogen Determination Near Surface of Nitriding Steel Using Nuclear Reaction Analysis (Liao Changgeng, et al.; HE JISHU, No 3, Mar 88) .....	40

#### BIOTECHNOLOGY

Determination of Effect of Mutation in TS20, DNA Mutant of Balb/3T3 Cells on DNA Topoisomerase II (Zeng Gui-chao; BEIJING YIKE DAXUE XUEBAO, No 2, Apr 88)	41
Rapid Detection of Heat-Labile E. Coli Enterotoxin by Immune Hemolysis (Li Shuqin; WEISHENGWUXUE TONGBAO, No 1, Feb 88) .....	48
Effect of Light Rare Earth Nitrates on Growth of Enteric Bacteria (Xu Shuxian; WEISHENGWUXUE TONGBAO, No 1, Feb 88) .....	49
Preliminary Study of Relationship Between Shigella Dysenteriae Coccus-Type and Tolerability Type (Pei Biao, et al.; WEISHENGWUXUE TONGBAO, No 1, Feb 88)	50
Isolation of Pathogenic L-Type Bacteria (Li Jinbao; WEISHENGWUXUE TONGBAO, No 1, Feb 88) .....	51

#### CHEMICAL ENGINEERING

Britholite-(Y) Discovered in China (Song Chunliu, et al.; KUANGWU XUEBAO, No 1, Mar 88) ....	52
Structural, Chemical Characteristics of Naturally-Occurring Uranium Oxides in China (Cai Genqing, et al.; KUANGWU XUEBAO, No 1, Mar 88) .....	53

#### COMPUTERS

New Battlefield-Hardened Computer Hardware (Xuan; JISUANJI SHIJIE, 20 Jan 88) .....	54
Zhonghuan, Changjiang Learning Computers Debut (Mu Gong; JISUANJI SHIJIE, 20 Jan 88) .....	55

Large-Capacity Disk Technology, Technical Hurdles Outlined (Gong Binliang, Zhang Yunpeng; JISUANJI SHIJIE, 20 Jan 88) .....	57
Problems in R&D, Production of Hard-Disk Drives Addressed (Huang Xuchen; JISUANJI SHIJIE, 20 Jan 88) .....	61
New Software for Taiji 2220 Undergoes Evaluation (Shao; JISUANJI SHIJIE, 27 Jan 88) .....	64
New Shenyang Microcomputers (DIANZI SHICHANG, 4 Feb 88) .....	65
First 32-Bit-CPU Workstation (JISUANJI SHIJIE, 2 Mar 88) .....	66
Automatic Chinese-Character Reading Machine (JISUANJI SHIJIE, 2 Mar 88) .....	67
5-1/4-Inch Diskette Drive (JISUANJI SHIJIE, 2 Mar 88) .....	68
Domestically Made North Star AT (JISUANJI SHIJIE, 2 Mar 88) .....	69
GF-10/11 Array Processor Completed (JISUANJI SHIJIE, 16 Mar 88) .....	70
High-Quality Chinese-Character Processing (JISUANJI SHIJIE, 16 Mar 88) .....	71
Improved Supermicrocomputer (JISUANJI SHIJIE, 16 Mar 88) .....	72
Programmable Controller Unveiled (JISUANJI SHIJIE, 16 Mar 88) .....	73
Interface for Secure Telecommunications (JISUANJI SHIJIE, 16 Mar 88) .....	74
Universal Microcomputer Structural Analyzer (GUANGMING RIBAO, 19 Mar 88) .....	75
New Great Wall Microcomputers (RENMIN RIBAO, 21 Apr 88) .....	76
TP-Series Microcomputers on World Market (RENMIN RIBAO, 21 Apr 88) .....	77
Briefs	
Computer Corp. Aims at International Market	78
Distributed Database Unveiled at Wuhan	78

Multifunctional Speech Processing System	78
1987 Computer Product Imports/Exports	79
High-Speed Data Acquisition System	79
'Kind' IC CAD System	79
First Automatic Network Monitoring System	80
Prototype Relational Knowledge Base Computer	80
First Domestic Ethernet LAN System	80
Advanced Development/Parallel Processing System	80
Shanghai Software Lab Products	81
Microcomputer Acceleration Board	81
Achievements of High-Tech Development Co.	81

#### EARTH SCIENCES

Policy Study on Offshore Pollution (Rao Beiya, Jiang Xia; ZHONGGUO HUANJING BAO, 1 Mar 88)	82
Determination of Trace Zirconium in Rocks, Minerals Containing Rare Earths, Uranium, Titanium by Derivative Spectrophotometry (Wang Changfa; YANKUANG CESHI, No 1, Mar 88) .....	84
Separation of Heavy Rare-Earth Elements by Thin-Layer Chromatography (Wang Jun, et al.; YANKUANG CESHI, No 1, Mar 88) .....	85
Briefs	
Radioactive Waste Plan Formulated	86

#### FACTORY AUTOMATION, ROBOTICS

Briefs	
Domestically Made Programmable Controller	87
Robot Vision System	87

#### LASERS, SENSORS, OPTICS

Error Analysis, Optimal Operational Area for Laser Ship-Model Tracking Instrument (Xu Gaoyue; SHANGHAI JIAOTONG DAXUE XUEBAO, No 2, Mar 88)	88
New Grating Sensor (JISHU SHICHANG BAO, 17 Feb 88) .....	90
Radiation of Dye Mixtures Pumped by N <sub>2</sub> Laser (Lei Jie, et al.; ZHONGGUO JIGUANG, No 3, 20 Mar 88) ....	91
Experimental Study of Self-Generated Magnetic Field in Corona Area of Laser Plasmas (Zhang Huihuang, et al.; ZHONGGUO JIGUANG, No 3, 20 Mar 88) .....	92

Cooperative Effects of Near-Resonance Electronic Raman Scattering in Pb Vapor (Huo Yunsheng, et al.; ZHONGGUO JIGUANG, No 3, 20 Mar 88)	93
Experimental Investigation of Cavity Configurations for CVL Pumped Dye Lasers (Tang Chuanshun, et al.; ZHONGGUO JIGUANG, No 4, 20 Apr 88) .....	94
Beam Divergence of Copper Vapor Laser Versus Efficiency of Dye Laser Pumped With It (Liang Peihui, et al.; ZHONGGUO JIGUANG, No 4, 20 Apr 88)	95
Expanding of Pulse Duration of Two-Channel Synchronous XeCl Excimer Laser (Cao Hongru, et al.; ZHONGGUO JIGUANG, No 4, 20 Apr 88)	96
Energy Levels, Spectroscopic Characteristics of BHA:Cr <sup>3+</sup> Crystals (Hu Zhiwei, et al.; ZHONGGUO JIGUANG, No 4, 20 Apr 88)	97
Briefs New-Generation Synthetic Aperture Radar	98

MICROELECTRONICS

100-Kilowatt High-Frequency Transmitter (DIANZI SHICHANG, 25 Feb 88) .....	99
Picosecond Time-Resolved Detection of Plasma Formation and Phase Transitions in Silicon (Ma Haiming, et al.; BANDAOTI XUEBAO, No 2, Mar 88) .....	100
Research on Application of Double Gettering Technique for CCD Fabrication and Its Increased Gettering Effect (Zhou Shiren, et al.; BANDAOTI XUEBAO, No 2, Mar 88) ....	100
Investigation of UV-VB-IR Spectra for Amorphous Semiconductor Superlattices (Mao Guomin, et al.; BANDAOTI XUEBAO, No 2, Mar 88) .....	101
Low-Temperature Ohmic Contacts on High-Resistivity Silicon (Li Gang, et al.; BANDAOTI XUEBAO, No 2, Mar 88) .....	101
Cross-Sectional TEM Observation of Non-Uniformity in Multiple Quantum Well Structures (Fan Tiwen; BANDAOTI XUEBAO, No 2, Mar 88) .....	101
High-Quality MBE GaAs-AlGaAs Quantum Well Structures (Liang Jiben, et al.; BANDAOTI XUEBAO, No 2, Mar 88) ....	102
Modifying the SiO <sub>2</sub> Surface State (Han Jieping, et al., BANDAOTI XUEBAO, No 2, Mar 88).....	102

## SUPERCONDUCTIVITY

New Superconducting Oxide Thin Film (WEN HUIBAO, 12 Feb 88) .....	103
Superconductivity Above 70 K in Ba-La-Cu Oxide (Cui Changgeng, et al.; DIWEN WULI XUEBAO, No 1, Mar 88)	104
Preparation of Ultra-Fine Ba-Y-Cu-O System Powder, Superconductivity (Zhang Han, et al.; DIWEN WULI XUEBAO, No 1, Mar 88) ....	105
Preparation of Ceramic Superconductor From Ultrafines by Freeze- Dry Process in Ba-Y-Cu-O System (Chen Zuyao, et al.; DIWEN WULI XUEBAO, No 1, Mar 88) ...	106
Research on Formation Energy of MPZ ( $E_{\min}$ ), Propagation of Normal Zone in Various Winding Techniques (Jiao Zhengkuan, et al.; DIWEN WULI XUEBAO, No 1, Mar 88)	107
Observation of Microstructure in NbTi/Cu Superconductors by SEM (Wu Xiaozu, et al.; DIWEN WULI XUEBAO, No 1, Mar 88) ....	108
R-H Superconducting Phase Transition in Nb <sub>3</sub> Sn Alloyed With Ti (Mao Xianglei, et al.; DIWEN WULI XUEBAO, No 1, Mar 88)	109
Briefs	
Superconductor Excitation Device	110
Superconductor Research Breakthroughs	110
Superconductor Motor	110

## TELECOMMUNICATIONS R&D

Achievements of MPT's Institute 10 (JISHU SHICHANG BAO, 3 Feb 88) .....	111
Digital Multiplexing Equipment (JISHU SHICHANG BAO, 6 Feb 88) .....	112
Subminiature Linear Predictive Vocoder (JISHU SHICHANG BAO, 13 Feb 88) .....	113
First 4-mm Diffraction Radiation Oscillator (JISHU SHICHANG BAO, 17 Feb 88) .....	114
Asynchronous Communications Modem (DIANZI SHICHANG, 18 Feb 88) .....	115
Minister Discusses Rural Radio, TV Development (Beijing Domestic Service, 7 May 88) .....	116

Radio Minister Investigates Hunan Situation (Hunan Provincial Service, 6 May 88) .....	117
---	-----

Briefs

Broadband Varactor Tuning for Radars	119
Microcomputer Target Monitoring System	119
Fiber-Optic Telephone System	119
High-Efficiency Communications Network	119
High-Frequency Tuning Module	120
2d-Generation Satellite Tracking and Control System	120
3-Meter Satellite Receiving Antenna	120
New Satellite TV Products	121
First 11.6-M Satellite Earth Station Antenna	121
Distributed Ethernet Integrated Communications System	121
Domestically Made Monitor for Comsat Launches	121
Asia's Largest Wangnet Computer Network	122
New Millimeter-Wave Device	122
Satellite Earth-Station Antenna	122
3-Meter Satellite Receiving Antenna	122
Urumqi Satellite Earth Station	122

/7310

## WUXI TO BECOME SOUTHERN 'SILICON VALLEY'; ESTABLISHMENT OF MICROELECTRONICS BASE SPEEDED UP

40080099 [Editorial Report] Beijing RENMIN RIBAO [PEOPLE'S DAILY] (Overseas Edition) in Chinese on 28 March 1988 reported on page 1 that establishment of the Wuxi Microelectronics Base--Southern China's "Silicon Valley," located in Jiangsu Province--is being speeded up; second-phase construction formally began on 5 March. According to an article in XINHUA RIBAO, this Silicon Valley is bounded by Taihu [Lake Tai], Hui Shan [Mount Hui], and the Beijing-Hangzhou Grand Canal.

The already completed first-phase construction centered on the Jiangnan Radio Equipment Factory and on Institute 24 of the Ministry of Electronics Industry, which are now China's largest discrete semiconductor components and IC research and production centers, respectively. Their products are widely used in computers, TV broadcasting, satellite communications, and precision instruments.

Second-phase construction, which closely borders on the northern side of the previous phase's work, covers an area of over 100 mu (i.e., over 6 2/3 hectares), with the buildings themselves occupying more than 100,000 square meters. Efforts are being concentrated on the erection of the multi-storied production and research buildings. The project is scheduled to be completed in 3 years, at which time the base's yearly output of models and linear integrated circuits will dramatically leap from the current 30 million to 100 million. This will be over 40 percent of China's production. Farther ahead, plans call for a yearly introduction of 30 to 50 new large-scale integrated-circuit products.

The importance of this base is indicated by the fact that top party and government leaders--including Zhao Ziyang, Li Peng, and Peng Zhen--have come to inspect the facilities. In addition, over 100 factories, research institutes, and schools have sent delegations totaling 50,000 visitors.

/06662

SCIENCE & TECHNOLOGY POLICY

Technology Exports Expand

40080102a Tianjin JISHU SHICHANG BAO [TECHNOLOGY MARKET NEWS] in Chinese  
27 Jan 88 p 1

[Summary] According to State statistics, 120 foreign contracts for technological exports totaling US\$160 million were signed in 1987, an eight-fold increase over 1986. Industries involved include astronautics, electronics, medical apparatus and instruments, computers, metallurgy, and agricultural chemicals. These goods are destined for the US, Japan, Hong Kong, France, the FRG, Austria, Poland, Indonesia, and Nepal.

/12223

SCIENCE & TECHNOLOGY POLICY

FRG's AEG To Set Up Training Centers

40080101a Tianjin JISHU SHICHANG BAO [TECHNOLOGY MARKET NEWS] in Chinese  
6 Feb 88 p 1

[Summary] The Federal Republic of Germany's AEG signed separate agreements a few days ago with the Ministry of Metallurgical Industry (MMI), the Ministry of Coal Industry (MCI), and the China National Nonferrous Metals Industry Corporation to set up the following training centers: a metallurgical automation research institute for MMI, a coal-mining technological development company for MCI, and a center at China North Industries University. According to the agreements, China will soon send the first group of six specialists to the FRG to receive training in AEG automated systems. AEG will provide equipment and instructors without charge to the centers, and within 5 years will invest over DM 1 million in each center.

/12223

Digital Switchboard Agreement With Philips

40080101b Beijing DIANZI SHICHANG in Chinese 25 Feb 88 p 1

[Summary] On 7 February, the Suzhou Wired Telecommunication Plant No 1, representing the China National Technical Import and Export Corporation, signed a contract with the Netherlands' Philips to import SOPHO-S program-controlled digital subscriber switchboard production technology with a designed capacity of 100,000 lines per year. According to the contract, Philips will transfer the switchboard technology, help to set up the production line, provide materials, and train technical personnel. This imported technology will create favorable conditions for establishing integrated services digital networks in China, and for developing computerized and noncomputerized telephone, television, teletype, and facsimile network-hookup methods.

/12223

Major Institutes' Role in Nation's Space Effort Outlined

40080106 Beijing HANGTIAN [SPACEFLIGHT] in Chinese No 2, 26 Mar 88 pp 28-29

[Article by Chen Daming [7115 6671 2494]: "Aerospace Colleges and Departments in China"]

[Text] At the request of the readers and to assist students in choosing an aerospace college or department, we publish this introduction to China's major institutes in aerospace and related disciplines. It must be pointed out that space science covers a broad scope. In addition to the colleges and departments listed here, students trained in many other science and engineering disciplines can also pursue a career in aerospace in the future.

Space College, Harbin Industrial University

Harbin Industrial University is a major university with a variety of disciplines. Aerospace engineering departments were established in 1945 and 1959. In June 1987, an Aerospace College was set up to train aerospace majors and graduate students, and to provide advanced specialists in aerospace research, design, manufacture, testing and teaching. The major has a 4-year program and applications from everywhere in China are accepted. The College has the following disciplines:

Automatic control. Training of advanced specialists in automatic flight guidance, vehicle control, computer control, and the control of the manufacture process.

Semiconductor physics and devices. Training of advanced specialists in the development and production of semiconductor devices.

Communications engineers. For the training of specialists in space communication (satellite communications, remote sensing and control), and other communications systems.

Electronic engineering. Training of advanced specialists in guidance, radar, image processing, language processing, and biomedical electronics.

Electronics and measurement technology. Training of specialists in automatic signal acquisition and processing, intelligent instrumentation, automatic measurements, and computer controlled measurements.

Engineering mechanics. For the training of specialists in structural strength calculation and design of space vehicles. This discipline includes solid mechanics, general mechanics, and flight mechanics.

The following departments of the Harbin Industrial University also train specialists in space flight: Department of precision instruments, department of dynamics engineering, department of computer science, department of electrical engineering, department of mechanical engineering, department of metal material and technology, department of applied chemistry, department of applied physics, department of applied mathematics, department of architecture engineering, and the college of management. The location of the university is on Sidazhi Street in the city of Harbin.

#### University of Defense Science and Technology

This is a major university in China and trains research, design, production, and testing specialists for China's defense technology. The university has a department of space technology and the following disciplines:

Aerodynamics. Studies of the movement of air and the interaction between object (flight vehicle) and gas. This discipline provides theoretical bases for the design of flight vehicles.

Structural strength of flight vehicles. Investigates the strength, rigidity, stability and other material related mechanical properties of missiles, satellites, and other vehicles under different conditions. The goal is to solve the structural strength and safety reliability problems in the design of flight vehicles.

Liquid and solid rocket engines. Studies the power system of missiles and satellites. Training of advanced specialists in the analysis, design, and testing of liquid and solid rocket engines.

Automatic control of vehicles. Training of specialists in the analysis, design, and development of the automatic control systems for satellites, missiles, and other space vehicles.

Space dynamics and flight testing. Investigating the laws of motion of space vehicles in flight, changing orbit, crossing and meeting. Studies the guidance, attitude dynamics, accuracy analysis, and testing optimization. Training of specialists in ballistic design, guidance method, testing and analysis, and accuracy evaluation.

Electronics engineering. The training of advanced specialists in system analysis, design, and computer signal processing for electronics systems including radar.

Signal processing, display, and recognition. Training of personnel in the analysis, design, and application of numerical image processing, color graphics display systems.

Microwave technology. Training of specialists in analyzing, designing and applying microwave antenna and microwave network using electromagnetic field theory.

Information engineering. Training of advanced specialists in the analysis, design, and application of satellite communications and modern signal transmission facilities and systems.

Metallic materials and heat treatment. Training of advanced technical personnel in metals research, analysis, testing, application and treatment.

Composite materials. Training of advanced technical personnel in composite properties, manufacture techniques, and product testing.

Solid propellant. Solid propellants are the new solid fuels for space vehicles. This discipline trains advanced technical personnel for designing, testing and producing solid rocket propellants.

Flight system engineering. This discipline trains engineers to conduct system planning, tactical analysis, subsystem coordination, parameter selection, performance analysis and computation, whole system optimization, and system testing for rockets and other space vehicles. The engineers are trained to use the basic theories and methods and to make use of modern scientific tools such as modelling, optimization, computer simulation, and automatic control.

Meters and testing instrumentation systems. This discipline mainly studies transduction measurement techniques, automatic testing, signal and data processing.

The university accepts applications from anywhere in China and has undergraduate and graduate programs. It is located in Changsha, Hunan.

#### Beijing Space College

This is also a major university and trains advanced personnel for China's aerospace industry. The following departments in the college are closely related to space: missile design, structural strength of vehicles, solid rocket engines, flight vehicle automatic control, inertia, guidance and instrumentation, flight dynamics, space vehicle production engineering, electronics engineering, metals and heat treatment, and high-polymer materials. The university has undergraduate and graduate programs. The undergraduate program is a 4-year program and accepts applications nationwide. The college is located on Xueyuan Road in Beijing.

## Beijing Polytechnical University

This is a major university in China. The following disciplines provide advanced specialists and technical personnel for the space enterprise: missile design, solid fuel rocket engine, launching facility and technique, automatic control, vehicle engineering, electronics engineering, and precision chemical engineering. The undergraduate program is 4 years and accepts applications nationwide. The school is located on Baishiqiao Road in Beijing.

## Space Engineering Department, Northwestern Polytechnical University

The Northwestern Industrial University is a major university in China. The Space Engineering Department was established in 1958 and has the following disciplines: missile design, solid fuel rocket engines, automatic control of flight vehicles, and flight dynamics. The department has undergraduate and graduate students and trains advanced personnel for China's aerospace undertaking. The university is on the 4-year system, accepts applications nationwide, and is located on Xianning Road in Xi'an, Shaanxi.

## Nanjing Aeronautical Engineering College

This college is also a major university in China. It trains advanced specialists and technical personnel for China's aeronautical industry. The following disciplines are closely related to space: engines, automatic control of space vehicles, inertial guidance and instrumentation, electronics engineering, aircraft manufacture, and aerodynamics. The university has undergraduate and graduate students, is on the 4-year system and accepts applications nationwide. It is located on Yudao Street in Nanjing, Jiangsu.

## Northwest Telecommunications Industrial College, Xi'an

This major university trains advanced specialists and technical personnel for China's electronics industry and aeronautics and space industry. The following disciplines are closely related to space science: telecommunications engineering, signal engineering, electronics engineering, automatic control, testing technology and instrumentation, computers and applications, precision electronic machinery, semiconductor physics and devices, photonics and microwave technology. The university has undergraduate and graduate students and accepts applications nationwide. It is on the 4-year system and is located on Taibai Road in Xi'an Shaanxi.

## Aerospace Engineering Department, Harbin Shipbuilding Engineering College

The college is a major one. The department has the following specialties: missile design, thermal energy engineering (solid-fuel rocket engine), automation of production process (automatic control of space vehicles), and electronics engineering (missile guidance). It has both undergraduate and graduate programs and accepts applications from all over China. It runs on a 4-year schedule and is located on Wenmiao Street in Harbin, Heilongjiang.

### Shanghai Jiaotong University

Jiaotong university in Shanghai is a major university in China and the following disciplines at Jiaotong University provide training for aerospace industry: automation, radio technology, telecommunications engineering, engineering mechanics, precision instrumentation, and computer and applications. The university trains undergraduate and graduate students. The undergraduate program is 4 years long and accepts applications throughout the country. The university is on Huashan Road in Shanghai.

### Qinghua University

Qinghua is a major university in China. It has the following space related disciplines: radio technology and signal systems, semiconductor physics and devices, automation and control, engineering mechanics, engineering thermal physics, precision instruments, environmental engineering, computer applications, and high polymer chemical engineering. Qinghua has undergraduate as well as graduate programs. The undergraduate program takes 5 years and accepts applications nationwide. The location is on the Qinghua campus in Haiding, Beijing.

### Beijing University

Beijing University is a major university in China. Space-related disciplines in this university are: space physics, astrophysics, geophysics, meteorology, mechanics, and applied chemistry. It has undergraduate and graduate students, accepts nationwide applications and is located in Loudouqiao, Haiding, Beijing.

### Aerospace Engineering Department, Beijing United University

This university was established to train advanced engineering and technical personnel for the space industry. It has the following specialties: mechanical design and manufacture, electronics and measurement technology, computer software, and industrial management. The undergraduate program is 4 years and the technical program is 3 years. It only accepts local students. The university is located on Gaoyuan Road, Donggaodi, in Fengtai, Beijing.

### North China Aerospace Industrial College

This is a three-year technical college under the Ministry of Aerospace Industry. It provides advanced application oriented technical personnel for the space industry. The following specialties are available: machine building and equipment, tool and die design and manufacture, testing techniques and equipments, radio technology, telecommunications engineering, computer applications, engineering management, industrial accounting, and industrial and civilian architecture. It accepts applicants nationwide and is located in Langfeng, Hebei.

9698/9738

THEORETICAL INVESTIGATION OF SEPARATED VORTEX MOTION, VORTEX BREAKDOWN FEATURE

40090090a Mianyang KONGQIDONGLIXUE XUEBAO [ACTA AERODYNAMICA SINICA] in Chinese Vol 6 No 1, Mar 88 pp 19-24

[English abstract of article by Lin Bingqiu [2651 3521 4428] of Beijing Institute of Aerodynamics]

[Text] This paper investigates some important problems involving a separated vortex, including the solution of incompressible and compressible viscous vortex core equations, the vortex breakdown region, the effects of the initial and outer-flow parameters on the vortex breakdown and the vortex breakdown mechanism. A theoretical method simulating the separated vortex breakdown over the leading edge of the slender delta-wing is presented. The results of the effects of the initial parameters on the vortex breakdown during high speed motion, the motion feature of the compressible viscous vortex and the effect of the compressibility are especially emphasized.

9717

VISCOUS/INVISCID INTERACTION ALGORITHM TO ANALYZE TRANSONIC AIRFOIL FLOWS WITH SEPARATION

40090090b Mianyang KONGQIDONGLIXUE XUEBAO [ACTA AERODYNAMICA SINICA] in Chinese Vol 6 No 1, Mar 88 pp 38-44

[English abstract of article by Zhang Huiliu [1728 1979 7511], et al., of Nanjing Aeronautical Institute]

[Text] Transonic flows of airfoils are analyzed with viscous/inviscid interaction concepts in this paper. A full potential airfoil code is coupled with the direct or inverse differential boundary layer method. The AF2 schemes and C-S box method are used for potential flow and boundary layer calculations, respectively. The modification to the turbulence model in separation regions makes the computed results correspond better to those of the experiments, indicating that the viscous/inviscid interaction concepts can be applied to the separated flows.

9717

CALCULATION OF GROUND EFFECT ON FLOW ABOUT AIRFOIL WITH REAR SEPARATION

40090090c Mianyang KONGQIDONGLIXUE XUEBAO [ACTA AERODYNAMICA SINICA] in Chinese Vol 6 No 1, Mar 88 pp 51-57

[English abstract of article by Jiang Linbo [5592 2651 3134], et al., of Beijing Institute of Aeronautics and Astronautics]

[Text] The ground effect is calculated using a new method in which the distribution of the source or vortex, rather than the imaginary system, is used to simulate the ground effect. The strength of singularities on the ground is simultaneously solved with the strength of singularities on the airfoil. The analytical solution is compared with the solution of the imaginary method, and they are in good agreement. In the present paper, the ground effect on the airfoil is calculated at a high angle of attack.

9717

VORTEX SYSTEM, PRESSURE DISTRIBUTION OF SLENDER BODIES WITH ELLIPTICAL CROSS SECTION NOSE AT HIGH ANGLE OF ATTACK

40090090d Mianyang KONGQIDONGLIXUE XUEBAO [ACTA AERODYNAMICA SINICA] in Chinese Vol 6 No 1, Mar 88 pp 64-69

[English abstract of article by Xiong Shanwen [3574 0810 2429], et al., of Beijing Institute of Aeronautics and Astronautics]

[Text] Vortex flow pattern visualizations and surface pressure measurements of slender bodies with elliptical cross section noses at a high angle of attack were conducted in water and wind tunnels at low speeds. The present investigation confirms the correlation between the nose shape and its complicated vortex system and the corresponding variation of cross-section pressure distributions and local side force along the axis at a high angle of attack and sideslip. By means of understanding the entire flow in detail, the mechanism of how a flattened nose shape contributes directional stability to the body is revealed.

9717

FORMATION MECHANISM OF ASYMMETRIC SPATIAL VORTEX OF SLENDER BODIES AT HIGH ANGLE OF ATTACK

40090090e Mianyang KONGQIDONGLIXUE XUEBAO [ACTA AERODYNAMICA SINICA] in Chinese Vol 6 No 1, Mar 88 pp 75-80

[English abstract of article by Wang Zixing [3076 1311 5281] of Nanjing Aeronautical Institute; Su Dai [5685 3782] of East China Institute of Technology]

[Text] The fluorescent mini-tuft method has been used to investigate the formation mechanism of the asymmetric spatial vortex of slender bodies at a high angle of attack in a low speed tunnel without sideslip. This investigation clearly shows the formation mechanism of the asymmetric spatial vortex. The strength and size of the vortex are increased with increments in the angle of attack. When the width of the leeside is not enough for the development of both side vortices, the weak vortex is pushed upward by the strong vortex. This investigation also shows the occasional and inevitable features of the asymmetric vortex. The effects of turbulence and adverse pressure are also discussed.

9717

## AERODYNAMIC CHARACTERISTICS OF VORTEX FLAP, COMBINATION WITH APEX FLAP

40090090f Mianyang KONGQIDONGLIXUE XUEBAO [ACTA AERODYNAMICA SINICA] in Chinese Vol 6 No 1, Mar 88 pp 81-90

[English abstract of article by Zhuang Fenggan [8369 6646 3927], et al., of Beijing Institute of Aeronautics and Astronautics]

[Text] Experimental methods, including aerodynamic pressure and force measurements, a seven-hole probe survey as well as new techniques using hydrogen bubbles and laser beams for flow visualization, were conducted to study the aerodynamic characteristics of three kinds of vortex flaps (i.e., constant chord, segmented and stepped) with a 74 degree swept delta wing as a basic planeform.

It has been found that the variation in planeforms and geometrical parameters has little effect on drag reduction to low lift under low angle of attack conditions. In order to improve the aerodynamic characteristics, two new devices formed by adding apex- and trailing-edge flaps to the basic delta wing have been studied. Experimental results show that these devices are capable of increasing lift with less drag penalty if the separated vortices shedding from the apex-flap are kept from breaking down by properly deflecting the apex-flap.

9717

EXPERIMENTAL INVESTIGATION OF FORMATION MECHANISM OF EFFECT OF SPIN NOSE TO  
ASYMMETRIC VORTICES ON SLENDER BODY AT HIGH ANGLE OF ATTACK

40090090g Mianyang KONGQIDONGLIXUE XUEBAO [ACTA AERODYNAMICA SINICA] in  
Chinese Vol 6 No 1, Mar 88 pp 98-103

[English abstract of article by Su Dai [5685 3782] of East China Institute of  
Technology; Wang Zixing [3076 1311 5281] of Nanjing Aeronautical Institute]

[Text] Experimental results of the spin nose of a slender body at a high  
angle of attack are presented, and the formation mechanism of the spatial  
vortices are also explained in this paper. The experimental results show  
that the vortex cannot be changed rapidly with the nose spin rate and,  
therefore, the asymmetric vortices on slender bodies at a high angle of  
attack can be inhibited.

9717

EXPERIMENTAL INVESTIGATION OF FORMATION, DECAY OF VORTEX UNDER INTERACTION OF  
JET WITH CROSSFLOW

40090090h Mianyang KONGQIDONGLIXUE XUEBAO [ACTA AERODYNAMICA SINICA] in  
Chinese Vol 6 No 1, Mar 88 pp 104-109

[English abstract of article by Sheng Chunhua [4141 2504 5478], et al., of  
Nanjing Aeronautical Institute]

[Text] Three different vortex systems exist in the flow field under the  
interaction of a jet with a crossflow--the bound vortex, wake vortex and shear  
vortex. In this paper, the mechanism of vortex formation is suggested, and  
interference among vortices is investigated based on observation and measure-  
ment by the fluorescent filament method and seven-hole probes. The major  
factors influencing the development and decay of the streamwise vortex are  
also analyzed and discussed.

9717

## VORTEX INTERACTION OF TWO WING-BODY MISSILE CONFIGURATIONS

40090090i Mianyang KONGQIDONGLIXUE XUEBAO [ACTA AERODYNAMICA SINICA] in Chinese  
Vol 6 No 1, Mar 88 pp 116-121

[English abstract of article by Feng Yanan [7458 0068 0589], et al., of  
Beijing Institute of Aeronautics and Astronautics]

[Text] Interactions in the vortex structures of two missile configurations with a cruciform set of wing panels at the incidence of 0-25 degrees have been investigated using the dye line, hydrogen bubble and laser sheet flow visualization in a water channel. A difference in the vortex structures of the wing-body combinations with "+" and "x" configurations was observed. The path and bursting point of the wing vortex core have been measured.

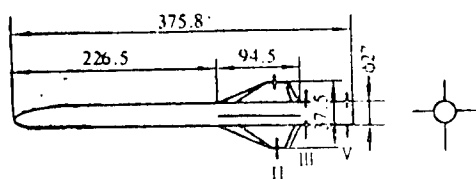

Figure 1. Model Dimensions  
(unit = mm). II, III, IV are  
cross section flow observation  
points.

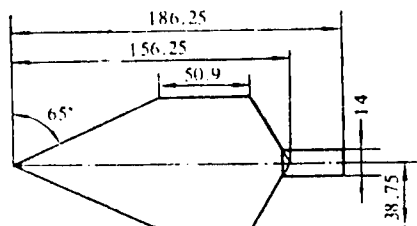

Figure 2. Wing Dimensions and  
External Configuration (unit = mm).

9717

CHARACTERISTICS OF ASYMMETRIC VORTICES, METHODS TO ALLEVIATE OFF-PLANE FORCES, MOMENTS

40090090j Mianyang KONGQIDONGLIXUE XUEBAO [ACTA AERODYNAMICA SINICA] in Chinese Vol 6 No 1, Mar 88 pp 137-141

[English abstract of article by Zeng Guangcun [2582 1639 1317], et al., of Beijing Institute of Aerodynamics]

[Text] This paper studies the phenomenon of off-surface forces and moments due to asymmetric vortices on cylindrical bodies [tactical missiles and combat aircraft] with Ogive noses at high angles of attack in subsonic and transonic flows. Methods to alleviate undesirable forces and moments are discussed. An appropriate nose configuration has been designed and tested. The results of wind tunnel experiments and laser vapor screen flow observation have proven the configuration to be effective. An unsteady region during the transition from symmetric vortices to asymmetric ones has been discovered.

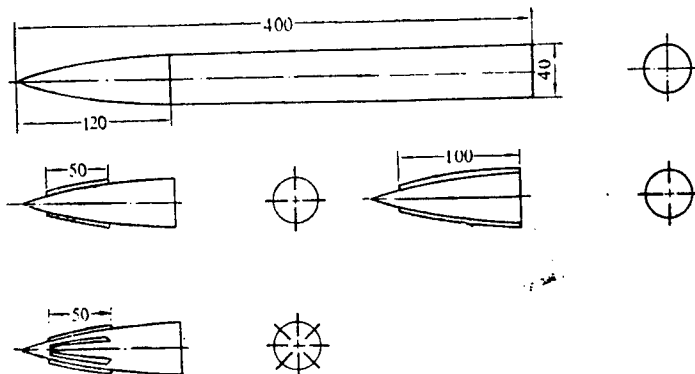

External design configuration for elimination of off-plane forces and moments.

9717

## Shanghai Develops Launch Vehicle for Nation's First Weather Satellite

40080113 Shanghai JIEFANG RIBAO in Chinese 3 Apr 88 p 1

[Excerpts] The Shanghai Space Complex is stepping up the development of a new launch vehicle in preparation for the launch of China's first meteorological satellite. This was announced yesterday at a meeting held in Shanghai to celebrate the successful launch of China's third communications satellite.

This new rocket has been independently designed, researched, and developed by the Shanghai Space Complex. The launch vehicle will be used to place China's first meteorological satellite into a polar, solar-synchronous orbit. The first of a new generation of satellite ground control stations will be used in the launch of this satellite; this facility was just completed the other day by the Shanghai Scientific Instruments Plant of the Ministry of Astronautics Industry and will be shipped to its base for installment and "debugging" shortly.

The head of the Shanghai testing unit, Shi Jinmiao [2457 6855 5379], states that his organization includes a dozen or so units of the Shanghai Space Agency and 152 personnel from the Shanghai Huadong Computer Institute, more than 100 of whom are S&T workers. He added that the communications satellite--launched on 7 March without a hitch by a Shanghai-developed Long March-3 rocket--had been placed in orbit at an altitude of 36,000 kilometers. The satellite continues to function normally in its mission to relay both broadcast and television communications. It will enjoy a longer service life than the previous two communications satellites.

/6091

Simulation Facility Has Major Role in Manned Space Program

40081064 Beijing RENMIN RIBAO (Overseas Edition) in Chinese 20 Apr 88  
p 4

[Article: "A Glimpse of China's Space Medico-Engineering Institute"]

[Text] In the field of space science research, scientists of the Chinese Institute of Space Medico-Engineering have put together more than 400 projects involving man-machine environmental systems engineering, combined Chinese traditional and Western medicine, and multi-discipline comprehensive research methods to create a complete manned ground simulation facility constructed for space medical engineering research. Having overcome some tough life support medical problems encountered in space, it is laying a solid foundation for a Chinese manned space program.

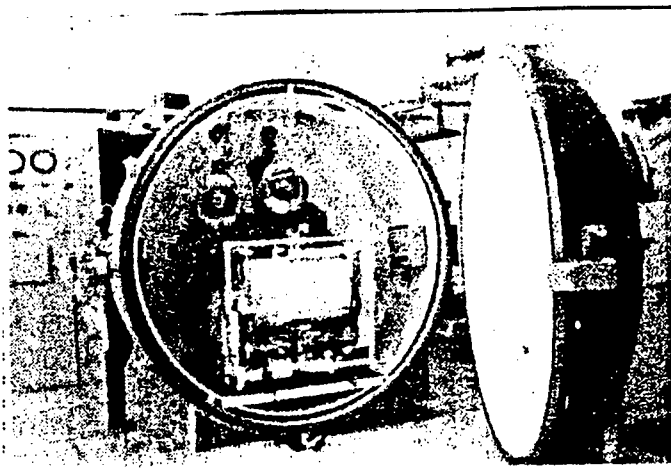

The life support system environment simulation test chamber used in spacecraft explosive decompression tests.

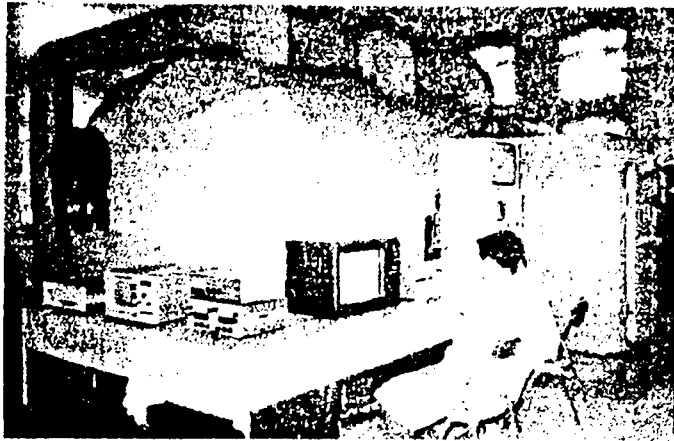

The Chinese-made spacecraft environment simulation facility used in selecting and training astronauts and for conducting scientific experiments.



Hydraulically powered rotating seat used in the astronaut selection and training program.

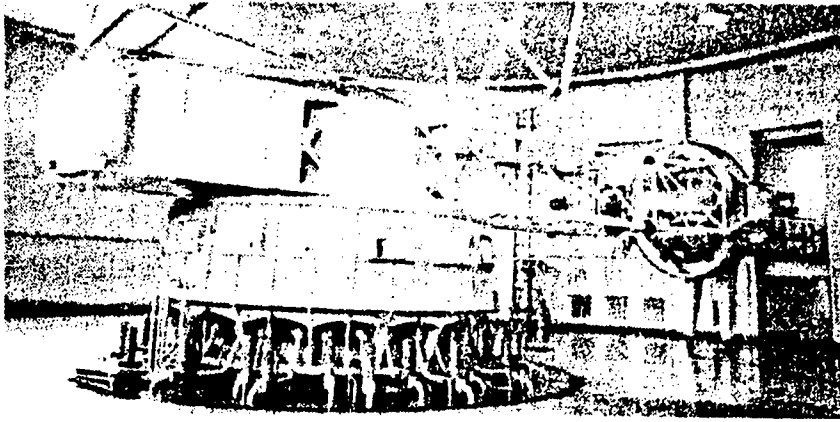

Chinese-made centrifuge used in astronaut selection and training and in conducting scientific experiments is the largest in Asia.

/12223

Medium-Wave Navigation Units

40080102c Beijing DIANZI SHICHANG in Chinese 4 Feb 88 p 2

[Summary] The models KDD-624 and KDD-625 medium-wave navigation units, certified at the ministry level and manufactured by the state-run Plant 8400, are intended for the Ministry of Aviation Industry's overall equipment replacement. These products use technologies such as semiconductor ICs, high power synthesis, and pulse-width-modulation switched voltage-regulated power sources. Features include fault warning, remote-control signal detection, and dual-unit automatic switchover. The 50 trial-production sets tested over the past year by Air Force, Navy, and civil-aviation authorities demonstrate that the units' performance is stable and that their emission power and efficiency are high. These products have applications for airports, oil-drilling platforms, large-scale shipping, and short/long-range aircraft navigation.

/12223

MEASUREMENT OF INFRARED OPTICAL CONSTANT DISPERSION CURVES OF FREE-STANDING THIN POLYESTER FILM BY KRAMERS-KRONIG RELATIONSHIP

40090078a Shanghai HONGWAI YANJIU [CHINESE JOURNAL OF INFRARED RESEARCH] in Chinese Vol 7A No 1, Feb 88 pp 15-21

[English abstract of article by Wang Yongtai [3769 3057 3141], et al., of the Central Laboratory, Nankai University]

[Text] The transmittance spectrum of free-standing thin polyester film is recorded with Fourier transform infrared spectroscopy. The interference fringes present in the above spectrum have been used to measure the refractive index in the high wave number region and the film thickness. The dispersion curves of the extinction coefficient  $K(\nu)$  and refractive index  $n(\nu)$  ( $3100-700 \text{ cm}^{-1}$ ) are obtained based on the continuous Kramers-Kronig analysis and the spectroscopic simulated calculation from the observed spectrum. The disturbance of the interference fringes has been thoroughly eliminated in these dispersion spectra. This method is suitable for all kinds of free-standing solid films.

9717

POLARITY STUDY OF RUBIDIUM ACID PHTHALATE (RAP) SINGLE CRYSTALS

40090078b Shanghai HONGWAI YANJIU [CHINESE JOURNAL OF INFRARED RESEARCH]  
in Chinese Vol 7A No 1, Feb 88 pp 39-46

[English abstract of article by Shi Zikang [0670 1311 1660], et al., of  
Fujian Institute of Research on the Structure of Matter, Chinese Academy of  
Sciences]

[Text] The pyroelectric properties related to polarity, including the pyroelectric effect, dielectric property and DC-conductivities of rubidium acid phthalate (RAP) crystal, are studied in this paper. Using differential temperature analysis (DTA) and weight loss analysis, a qualitative explanation is given of the temperature dependence of high-temperature thermoelectricity. The positron annihilation technique (PAT) is used to successfully determine the negative single vacancy distribution in the positive and negative directions of the polar axis. The authors' experiment verifies that the DC-conductivities of the RAP crystals are caused by the thermal defect in the crystal.

9717

PARALLEL DIGITIZED INTERFEROMETER PROPOSED

40090078c Shanghai HONGWAI YANJIU [CHINESE JOURNAL OF INFRARED RESEARCH]  
in Chinese Vol 7A No 1, Feb 88 pp 61-68

[English abstract of article by Wang Zhaoshen [3769 0340 3947], et al., of  
the Institute of Plasma Physics, Chinese Academy of Sciences]

[Text] The concept of a parallel-digitized interferometer used for the phase  
measurement of a transient process is proposed. The interferometer system,  
software design and measurement errors are discussed. The details of a  
35 GHz model and its experimental results are given. The results show that  
the parallel-digitized system provides good performances and will have many  
applications in plasma research and other areas.

9717

STUDIES ON DIFFUSION PROCESS OF FISSIONING NUCLEAR SYSTEM.\* I. ANALYSIS OF  
PROCESS APPROACHING EQUILIBRATION

40090073a Beijing YUANZIHE WULI [CHINESE JOURNAL OF NUCLEAR PHYSICS] in  
Chinese Vol 10 No 1, Feb 88 pp 16-23

[English abstract of article by Feng Renfa [7458 0088 4099], et al., of the  
Institute of Atomic Energy, Beijing]

[Text] The diffusion motion of a fissioning system by the propagator method  
used to solve the Fokker-Planck equation is described. More attention is  
paid to the process approaching equilibration for a fissioning system from  
the ground state over the saddle point to the scission point, and the time  
evolution of the distribution, the fission rate at saddle point and the  
mean value, as well as the variance of the kinetic energy at the scission  
point, are computed for different friction coefficients and temperatures.

\* Project supported by National Natural Science Foundation of China.

9717

STUDY OF ( $\alpha$ , p) THREE NUCLEON TRANSFER REACTIONS OF ODD A NUCLEI IN  $1f_{1/2}$  SHELL

40090073b Beijing YUANZIHE WULI [CHINESE JOURNAL OF NUCLEAR PHYSICS] in Chinese Vol 10 No 1, Feb 88 pp 39-45

[English abstract of article by Yuan Rongfang [5913 1369 5364], et al., of the Institute of Atomic Energy, Beijing]

[Text] Using 25.7 MeV alpha particles, the differential cross sections are measured for the ground state ( $0^+$ ), 0.835 MeV ( $2^+$ ) state and 1.824 MeV ( $4^+$ ) state of  $^{54}\text{Cr}$  corresponding to the  $^{51}\text{V}(\alpha, p)^{54}\text{Cr}$  reaction, and for the 0.81 MeV ( $2^+$ ) state, 1.675 MeV ( $2^+$ ) state and 2.08-2.26 MeV ( $4^+$ ,  $3^+$ ,  $0^+$ ) state of  $^{58}\text{Fe}$  corresponding to the  $^{55}\text{Mn}(\alpha, p)^{58}\text{Fe}$  reaction. The angular distributions of the different states for the two reactions are calculated for various possible transfer angular momenta. Calculations are carried out using the zero range DWBA theory with a quasi-triton process. The results show that, in the case of the odd A nuclei, although the transfer angular momenta are not the only value, in the fitting it can be found that only one transfer angular momentum is dominated in the angular distribution. The ( $\alpha$ , p) reactions on the odd A nuclei also have j-dependence for  $\ell=3$  transition, but not as strong as for the  $\ell=1$  transition.

9717

SMALL ANGLE, TOTAL ELASTIC SCATTERING CROSS SECTIONS OF FAST NEUTRONS

40090073c Beijing YUANZIHE WULI [CHINESE JOURNAL OF NUCLEAR PHYSICS] in Chinese Vol 10 No 1, Feb 88 pp 46-51

[English abstract of article by Li Jingde [2621 2529 1795], et al., of the Institute of Nuclear Science and Technology, Sichuan University, Chengdu]

[Text] The 14.2 MeV neutron elastic scattering differential cross sections of Al, Ti, Fe, Cu and Cd are measured by the associated particle time of flight method at small angles. The corrections for neutron fluence attenuation, multiple scattering and finite geometry are performed using the Monte-Carlo method. The experimental results are compared with the optical model calculations. The total elastic scattering cross sections of Al, Ti, Fe, Cu, Cd, Pb, Bi and  $^{238}\text{U}$  are given.

9717

THEORETICAL ANALYSIS OF EFFECTS OF MISALIGNMENTS IN NONLINEAR BEAM TRANSPORT SYSTEM

40090073d Beijing YUANZIHE WULI [CHINESE JOURNAL OF NUCLEAR PHYSICS] in Chinese Vol 10 No 1, Feb 88 pp 75-85

[English abstract of article by Liu Chunliang [0491 4783 0081], et al., of Xi'an Jiaotong University]

[Text] The effects of the misalignments of the transport elements in a nonlinear beam transport system are analyzed theoretical, and the influence of the misalignments on the phase space trajectories of charged particles is studied. The third order transfer equations of the mean vector and the second order central moments are derived by the moment method in which the known misalignments and uncertain misalignments, respectively, are taken into consideration.

9717

ELECTRON STRIPPING CROSS SECTION OF IONS BY ATOMS

40090073e Beijing YUANZIHE WULI [CHINESE JOURNAL OF NUCLEAR PHYSICS]  
in Chinese Vol 10 No 1, Feb 88 pp 93-96

[English abstract of article by Zhang Xixiang [1728 6932 4382], et al., of the University of Science and Technology of China, Hefei; Tsutomu Watanabe of the Institute of Physical and Chemical Research, Wakoshi, Japan]

[Text] Electron stripping cross sections of  $Cq^+$  and  $Neq^+$  ( $q = 1-5$ ) ions by collisions with the target atom H are calculated using the binary encounter approximation. The electron velocity distribution in the ion is obtained by the Thomas-Fermi statistical model. The velocity distribution of electrons in the H target is given by the wave function of H. Electron stripping cross sections of ions by collisions of ions, electrons with the nucleus and electrons of the target are calculated respectively, and their values are compared. Finally, comparisons of the calculated values with the experimental data are made.

9717

STUDY OF WEAR RESISTANCE OF STEEL SAMPLES IMPLANTED WITH  $N^+$  IONS OR NITRIDED

40090087a Shanghai HE JISHU [NUCLEAR TECHNIQUES] in Chinese Vol 11 No 3,  
Mar 88 pp 3-6, 58

[English abstract of article by Wang Tianmin [3769 1131 3046], et al., of Lanzhou University; Wu Meizhen [0702 5019 3791], et al., of the Institute of Modern Physics, Chinese Academy of Sciences]

[Text] Steel samples of 9Cr18, GCr15 and Cr12MoV were subjected to different treatments, i.e., ion implantation, gas and ion nitridation and quenching. Lower load wear tests of the specimens were performed. The wear resistance of  $N^+$  implanted samples were found to be the best. Results showed that the more elements formed the nitrides, the more significant was the improvement in wear resistance. AES, XPS, TEM and X-ray diffraction examinations were performed to study comprehensively the structures and compositions of the samples.

9717

INFLUENCE OF ION IMPLANTATION ON FRICTION PROPERTIES OF SOFT METAL MATERIALS

40090087b Shanghai HE JISHU [NUCLEAR TECHNIQUES] in Chinese Vol 11 No 3,  
Mar 88 pp 6-9, 58-59

[English abstract of article by Hu Zhengqiong [5170 2973 8825], et al., of  
Beijing Institute of Aeronautics and Astronautics]

[Text] Silver samples and bronze samples coated with boron, silver, indium or tin films through vacuum deposition were bombarded with nitrogen ions. Wear tests were conducted on the samples under different conditions--either a lower spin rate with lower loads and dry friction or a high spin rate with heavy loads and oil lubrication. Results show that the coefficients of friction became much smaller for most of the ion-implanted samples. Discussions of the mechanism of the friction reduction effect are presented.

9717

IMPROVEMENT OF OXIDATION RESISTANCE OF STEEL SAMPLES BY ION BEAM MIXING

40090087c Shanghai HE JISHU [NUCLEAR TECHNIQUES] in Chinese Vol 11 No 3,  
Mar 88 pp 9-12

[English abstract of article by Liu Xianghuai [2692 5980 2037], et al., of  
Shanghai Institute of Metallurgy, Chinese Academy of Sciences]

[Text] Specimens of the heat resistant steel 4Cr9Si2 were deposited with 60 nm  $\text{Si}_3\text{N}_4$  or Si films and implanted with  $5 \times 10^{16} \text{ cm}^{-2}$  of 120 keV  $\text{N}^+$  or  $\text{Ar}^+$  ions. Oxidation kinetics and SEM studies showed that the oxidation resistance of the steel samples was significantly improved after ion beam mixing. It was found that the lifetime of the dies made of the steel and used for making glass covers for bus lamps was lengthened by the ion beam mixing. TEM, AES and XPS examinations and Monte Carlo simulations were conducted to study the effects.

9717

EFFECTS OF IMPLANTATION WITH N, B, Cr, Mo IONS ON CORROSION BEHAVIOR,  
MICROHARDNESS OF PURE IRON SAMPLES

40090087d Shanghai HE JISHU [NUCLEAR TECHNIQUES] in Chinese Vol 11 No 3,  
Mar 88 pp 15-17, 59-60

[English abstract of article by Lu Haolin [4151 3185 3829], et al., of the  
Institute of Atomic Energy of China]

[Text] Studies of anodic polarization in 0.5 mol/l  $H_2SO_4$  were conducted to examine the corrosion behavior and microhardness of surface alloys formed by implanting N, B, Cr and Mo ions into pure iron specimens. No notable change in the corrosion potential was observed. The critical and passive current densities, however, decreased markedly. It was found that the range of passivity increased and the microhardness improved. The results also suggested that multi-element ion implantation is better than single-element ion implantation.

9717

EFFECTS OF ION IMPLANTATION ON PERFORMANCE OF ELECTRIC CONTACTS

40090087e Shanghai HE JISHU [NUCLEAR TECHNIQUES] in Chinese Vol 11 No 3,  
Mar 88 pp 21-24, 60

[English abstract of article by Xu Shiru [1776 1709 1172], et al., of Xi'an Jiaotong University; Zheng Tianpi [6774 1131 0012] of the State Manufactory No 792]

[Text] Two kinds of electric contacts were implanted with  $1 \times 10^{17}/\text{cm}^2$   $\text{N}^+$  and  $\text{N}_2^+$ , then a make and break test was conducted with the low voltage electric apparatus. Parameters such as the weight loss of the contacts, temperature rise, contact resistance and transfer of material between two contacts were measured, and some valuable results have been obtained. All the parameters decreased in the contacts implanted with ions when compared with those unimplanted after the make and break. It is shown that ion implantation shows promise for improving the performance of electric contacts.

9717

SURFACE MODIFICATION OF AERO-BEARING

40090087f Shanghai HE JISHU [NUCLEAR TECHNIQUES] in Chinese Vol 11 No 3,  
Mar 88 pp 25-26, 60-61

[English abstract of article by Wang Yirong [3769 1355 2837], et al., of Chengdu Aeroengine Company; Lu Haolin [4151 3185 3829], et al., of the Institute of Atomic Energy of China; Wang Peilu [3769 1014 6922], et al., of the Institute of Nuclear Science and Technology, Sichuan University]

[Text] Different ion beam techniques, i.e., ion beam mixing and ion implantation by either single- or multi-element ions, were adopted to modify surface properties of aero-bearing samples that were made of GCr15 or Cr4Mo4V alloys. Results show that the corrosion behavior and wear resistance of the samples treated with any of the techniques were significantly improved.

9717

ANODIC POLARIZATION OF HARD ALUMINUM: INFLUENCE OF ION BEAM TWICE MIXING  
ON CORROSION BEHAVIOR

40090087g Shanghai HE JISHU [NUCLEAR TECHNIQUES] in Chinese Vol 11 No 3,  
Mar 88 pp 47-50, 63

[English abstract of article by Wang Peilu [3769 1014 6922], et al., of the  
Institute of Nuclear Science and Technology, Sichuan University]

[Text] Protective layers on the hard aluminum substrate have been formed by Cr ion beam once mixing, twice mixing and oxidizing. The anodic polarization curves and annular polarization curves of every sample have been measured with the three electrode potentiodynamic scanning method in 3 percent NaCl solution. The electrochemical parameters of the samples with ion beam twice mixing treatment are superior to those of samples with once mixing or oxidizing treatments. RBS analysis gives the Cr concentration profile in the samples, showing that Cr is well mixed with the matrix on the surface during ion beam twice mixing.

9717

NITROGEN DETERMINATION NEAR SURFACE OF NITRIDING STEEL USING NUCLEAR REACTION ANALYSIS

40090087h Shanghai HE JISHU [NUCLEAR TECHNIQUES] in Chinese Vol 11 No 3, Mar 88 pp 55-57, 64

[English abstract of article by Liao Changgeng [1675 1603 1649], et al., of the Institute of Nuclear Research, Lanzhou University]

[Text] The optimum conditions for nitrogen determination near the surface of nitriding steel using a  $^{15}\text{N}(p, \alpha\gamma)^{12}\text{C}$  nuclear reaction have been investigated. The detection limit of nitrogen for nitriding steel is about 0.03 wt percent at incident proton energy  $E_p = 1$  MeV. The practical measurements show that the surface nitrogen content is  $(9.1 \pm 0.6)$  wt percent for the 40Cr steel sample placed in the middle of a nitriding furnace and is obviously decreased for samples placed at the upper or lower positions near the edge. The depth profile of nitrogen in nitriding steel near the surface is also discussed.

9717

Determination of Effect of Mutation in TS20, DNA Mutant of Balb/3T3 Cells on DNA Topoisomerase II

40081067 Beijing BEIJING YIKE DAXUE XUEBAO [JOURNAL OF BEIJING MEDICAL UNIVERSITY] in Chinese Vol 20 No 2, Apr 88

[Article by Zeng Gui-chao [2582 2710 6389] Department of Biochemistry, Beijing Medical University]

[Text] A temperature-sensitive mutant of Balb/3T3 cells, ts20, is defective in an early step of DNA chain elongation. Previous work has shown an association of the defect with the activity of DNA topoisomerase I. In the studies presented herein we looked for evidence implicating the activity of DNA topoisomerase II. Mutuant, revertant and wild-type cells were equally sensitive to killing by novobiocin, a drug that inhibits the activity of DNA topoisomerase II. The degree of inhibition of cell DNA synthesis *in vivo* and *in vitro* in mutant cells at restrictive temperature was also unaltered by the presence of the drug. The mutation had no effect on cell chromatin conformation or on supercoiling of mature polyomavirus DNA molecules. Our results provide evidence that DNA topoisomerase II is not affected by the mutation in ts20.

Ts20 is a temperature-sensitive mutant derived from Balb/3T3 cells. The defect inhibits polyomavirus and cell DNA synthesis at an early step of chain elongation and is expressed *in vitro*<sup>(1)</sup>. Although the ts gene product is essential for both cell and virus DNA replication, the block to cell DNA synthesis is reversible while the block to virus DNA synthesis is not<sup>(1,2)</sup>. Analysis of virus DNA synthesized *in vitro* in the mutant under restrictive conditions shows a series of DNA topoisomers migrating between form I and form II DNA on agarose gel electrophoresis. There is also an associated decrease of DNA topoisomerase I activity<sup>(3)</sup>.

There are two types of topoisomerases. The biological functions of the enzymes are not clear<sup>(4)</sup>. The activity of both type I and type II enzymes may be associated with cell proliferation<sup>(5)</sup>, and malignant cell growth<sup>(6)</sup>. Novobiocin specifically inhibits the activity of type III topoisomerases by competing for ATP binding sites<sup>(7,8)</sup>. Inhibition of DNA topoisomerase II by novobiocin results in changes in superhelicity of DNA<sup>(9,10)</sup>. Inhibition of Simian virus 40 DNA synthesis by hypertonic block to the type II enzyme causes an accumulation of catenated dimer DNA molecules<sup>(11)</sup>. Since our previous work had implicated DNA topoisomerase I in the defect in ts20, it was of interest

to learn whether DNA topoisomerase II was also affected. In the experiment reported here, we show that mutant, revertant and wild-type cells were equally sensitive to novobiocin and that restrictive conditions caused no change in the conformation of cell chromatin or mature polyomavirus DNA.

## Materials and Methods

### Cells and Virus

We have described previously our methods of culturing mutant ts20 cells, revertant ts20R cells and wild-type Balb/3T3 cells and infecting with polyomavirus<sup>(1)</sup>.

### DNA Synthesis In Vitro and In Vitro

Infected and uninfected cells were maintained at 33°C or 39°C and containing <sup>3</sup>H-thymidine (5 µCi/ml, 74 Ci/mmol, New England Nuclear). The pulse time was 30 min. Radioactivity synthesis in vitro was determined by precipitation with trichloroacetic acid (TCA)<sup>(1)</sup>. Cell and virus DNA synthesis in vitro was performed in lysed-cell DNA synthesizing system we previously described<sup>(1)</sup> in which cells are lysed with low concentrations of Brij-58. If infected cells were used, the ratio of <sup>3</sup>H-dTTP on non-radioactive dTTP in the in vitro reaction mixture was increased four-fold above that used ordinary<sup>(1)</sup> to obtain sufficient incorporation of radioactivity. The in vitro reaction was carried out at 33°C or 39°C for 60 min. The samples were diluted three-fold with 50 mmol/L HEPES, pH 7.8, and 10 mmol/L EDTA. The virus DNA was extracted by the Hirt procedure<sup>(12)</sup>. Then, the virus DNA in the Hirt supernatant was analyzed by agarose gel electrophoresis as described previously<sup>(3)</sup>.

### Velocity Sedimentation of Cell DNA in the Presence of Ethidium Bromide

Cell DNA was analyzed according to the procedure described by Cook and Brazell<sup>(13)</sup> modified as follows. Cells were grown to a density of 2.5x10<sup>5</sup> cells per 60 mm culture dish at 33°C. They were maintained at 33°C for 12 h and labeled with <sup>14</sup>C-thymidine (0.05 µCi/ml, 60 mCi/mmol) for 2 h before harvest or shifted to 39°C for 12 h and labeled with <sup>3</sup>H-thymidine (5 µCi/ml, 74 Ci/mmol) for 2 h before harvest. Then, they were washed with phosphate-buffered saline (PBS), collected and resuspended in PBS (5x10<sup>6</sup> cells/ml). 50 µl of cell suspension labeled with <sup>3</sup>H was mixed with 50 µl of suspension of the same cell type labeled with <sup>14</sup>C. Mixed cell suspensions were layered on top of 5 ml linear density gradients of 5 to 30% (wt/vol) sucrose in 50 mmol/L Tris-HCl, pH 7.8, 10 mmol/L EDTA, 1.0 mol/L NaCl and different concentrations of ethidium bromide. 100 µl of lysed bugger (50 mmol/L Tris-HCl, pH 7.8, 10 mmol/L EDTA, 1.0 mol/L NaCl and 1% Triton X-100) was added to the cell layer and lysis was allowed to proceed for 20 min at room temperature. Centrifugation was carried out in a SW50.1 rotor at 6,000 rpm for 60 min at 20°C. Fractions were collected from the bottom and analyzed for acid-insoluble radioactivity by TCA precipitation.

## Equilibrium Gradients of Polyomavirus DNA in the Presence of Ethidium Bromide

Determination of the degree of supercoiling of virus DNA was performed as described by Edenberg<sup>(10)</sup>. Cells were infected with polyomavirus and incubated at 33°C for 24 h. Then, infected cells incubated at 33°C or 39°C for a further 12 h were labeled with <sup>14</sup>C-thymidine (0.1 µCi/ml) or <sup>3</sup>H-thymidine (25 uCi/ml) for 30 min. Virus DNA was isolated by the Hirt procedure and the Hirt supernatant was deproteinized with chloroform-isoamyl alcohol (24:1). <sup>3</sup>H-labeled DNA was mixed with <sup>14</sup>C-labeled DNA isolated from the same kind of cells, adjusted to a refractive index of 1.388 with cesium chloride, buffer (10 mmol/L Tris-HCl, pH 8.0, 10 mmol/L NaCl, 1.0 mmol/L EDTA) and ethidium bromide (final concentration of 0.27 mg/ml). Centrifugation was carried out in a Beckmen VTi 80 rotor at 70,000 rpm for 8 h at 20°C. Fractions were collected from the bottom and analyzed for acid-insoluble radioactivity by TCA precipitation.

Concentration of Novobiocin (µg/ml)

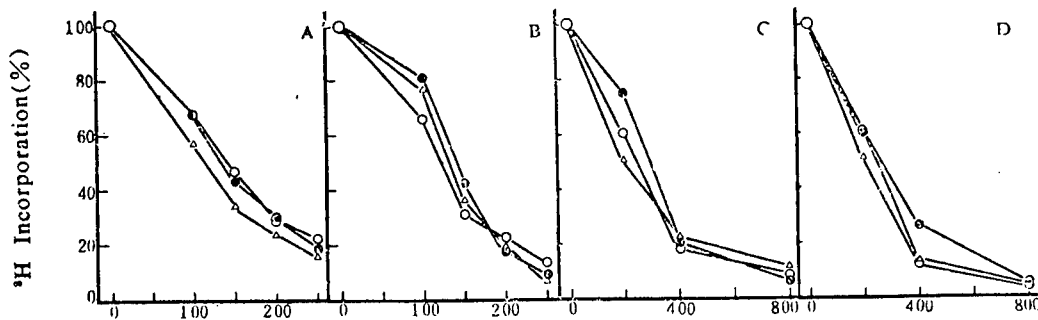

Figure 1. DNA Synthesis in the Presence of Novobiocin

(A) and (B): in vivo DNA synthesis.  $5 \times 10^5$  cells were incubated in the presence of varying concentrations of novobiocin (A) at 33°C and (B) at 39°C for 12h. DNA synthesis was measured as described in text. (C) and (D): in vitro DNA synthesis.  $2.5 \times 10^6$  cells were (C), maintained at 33°C, or (D), shifted to 39°C for 12h. After lysis with 0.01% Brij-58, in vitro DNA synthesis in the presence of novobiocin was performed (C), at 33°C, or (D), at 39°C for 60 min with <sup>3</sup>H-dTTP. dTTP incorporation was calculated as described previously<sup>(1)</sup>. (·)ts20 cells, (°)3T3 cells, and (◊) revertant ts20R cells.

Ethidium Bromide (µg/ml)

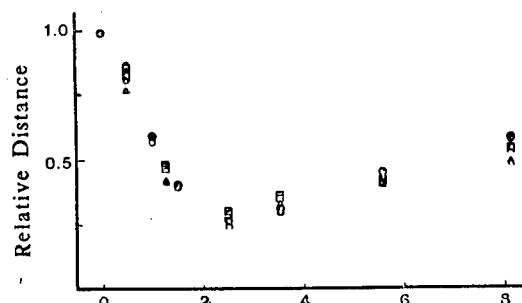

Figure 3. Ethidium Bromide Titration of Supercoiled Cell DNA

Cells were labeled with <sup>14</sup>C-thymidine at 33°C or with <sup>3</sup>H-thymidine at 39°C lysed on top of 5-30% neutral sucrose gradients and centrifuged in the

presence of ethidium bromide. The data are plotted as the ratio of the distance of the DNA sedimented in the presence of ethidium bromide to that in the absence of ethidium bromide. Wild-type 3T3 cells at 33°C (•) and at 39°C (◦); mutant ts20 cells at 33°C (△) and at 39°C (◦); revertant ts20R cells at 33°C (■) and at 39°C (◻).

## Results

We grew mutant, wild-type and revertant cells in the presence of 0 to 250 µg/ml of novobiocin. The survival of cells was determined by colony formation at the permissive temperature of 33°C. The viability of all cell lines decreased with doses of novobiocin above 50 µg/ml. There was no enhanced sensitivity in mutant cells to killing by the antibiotic (data not shown). We then determined the inhibition of DNA synthesis by novobiocin at permissive and restrictive temperature, in vivo and in vitro. The inhibition of DNA synthesis at the permissive temperature in vivo (Figure 1A) and in vitro (Figure 1C) by the antibiotic was quite similar in mutant and control cells. At the restrictive temperature, DNA synthesis in mutant cells in the absence of novobiocin decreased to 40 percent of that at the permissive temperature, but further inhibition in the presence of novobiocin was similar in vivo (figure 1B) and in vitro (Figure 1D) to control cells.

Polyomavirus DNA synthesized in the lysed mutant cells at the permissive temperature in the presence of novobiocin was analyzed by electrophoresis (Figure 2). It decreased as the concentration of novobiocin increased. The drug caused an accumulation of replicative intermediates and the disappearance of mature form I DNA but no accumulation of less supercoiled topoisomers characteristic of the mutant phenotype. The experiment showed the effect of novobiocin was different from that of the ts mutation. Novobiocin is considered an inhibitor of DNA topoisomerase II. Since the pattern of virus DNA obtained in its presence is totally different from that obtained with ts20 does not have a defect in DNA topoisomerase II activity.

We examined cell chromatin conformation by velocity sedimentation in the presence of ethidium bromide as described by Cook and Brazell<sup>(14)</sup> with cells incubated at 33°C or 39°C. In brief, mutant cells, wild-type cells and revertant cells incubated at 33°C were pulse-labeled with <sup>14</sup>C-thymidine while those incubated at 39°C for 12 h were pulse-labeled with <sup>3</sup>H-thymidine. <sup>3</sup>H- and <sup>14</sup>C-labeled cells were mixed, lysed and centrifuged in the presence of ethidium bromide. The results are shown in Figure 3. The velocity sedimentation of dye-bound DNA changed as the concentrations of ethidium bromide increased. The curves obtained from mutant cells and control cells at 33°C and 39°C were similar. There were no significant differences in sedimentation among three types of cells or between the two temperatures, indicating that the mutant phenotype had no effect on chromatin conformation.

Edenberg<sup>(10)</sup> reported that SV40 DNA synthesized in the presence of novobiocin exhibits less negative supercoiling. This was demonstrated by equilibrium centrifugation of virus DNA in ethidium bromide-CsCl gradients. It was of interest to see whether this procedure could detect a difference in mature polyomavirus DNA molecules synthesized in control and mutant cells.

$^3\text{H}$ -labeled virus DNA was extracted from infected mutant cells and control cells that had been incubated at  $39^\circ\text{C}$  for 12 h.  $^{14}\text{C}$ -labeled virus DNA was extracted from cells maintained at  $33^\circ\text{C}$ . Mixture of  $^3\text{H}$ - and  $^{14}\text{C}$ - DNA were subjected to cesium chloride equilibrium gradients in the presence of  $270\ \mu\text{g/ml}$  ethidium bromide. The results in Figure 4 showed no difference in buoyant densities of virus DNA prepared from three types of cells at  $33^\circ\text{C}$  and  $39^\circ\text{C}$ . This meant that the ts defect in mutant cells had no effect on the supercoiled density of mature virus DNA.

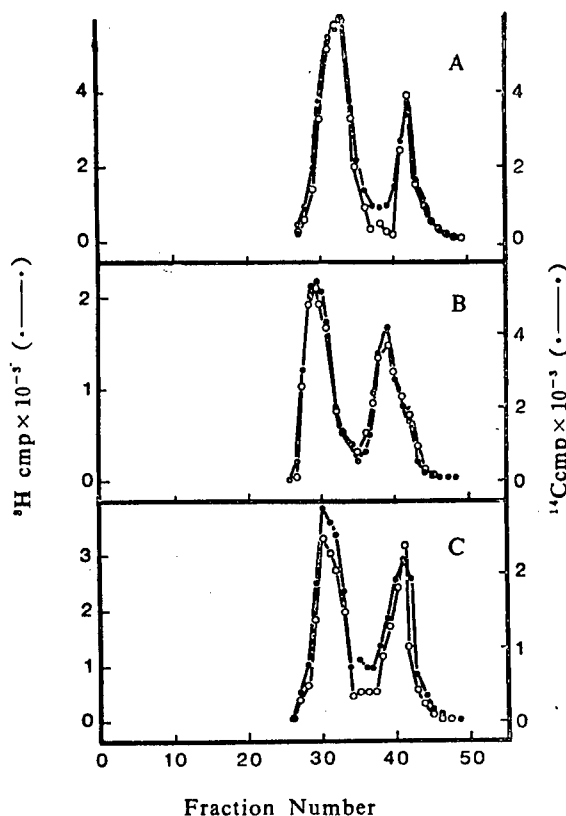

Figure 4. Ethidium Bromide-Cesium Chloride Equilibrium Gradients of Virus DNA

After infection with polyomavirus, (A) wild-type 3T3 cells, (B) mutant ts20 cells and (C) revertant ts20R cells were maintained at  $33^\circ\text{C}$  for 36 h and labeled with  $^{14}\text{C}$ -thymidine for 30 min ( $\bullet$ ), or at  $33^\circ\text{C}$  for 24 h and then shifted to  $39^\circ\text{C}$  for 12 h and labeled with  $^3\text{H}$ -thymidine for 30 min ( $\circ$ ). The Hirt supernatants were extracted with chloroform/isoamyl alcohol (24:1).  $^3\text{H}$ - and  $^{14}\text{C}$ -labeled DNAs prepared from the same kind of cells were mixed and adjusted to a refractive index of 1.388 with CsCl and ethidium bromide (final concentration of  $0.27\ \text{mg/ml}$ ). Centrifugation was carried out in a Beckman VTi80 rotor at 70,000 rpm for 8 h at  $20^\circ\text{C}$ . Fractions were collected from the bottom.

#### Discussion

Our early results show that the mutation in ts20 is associated with DNA topoisomerase I activity.<sup>(3)</sup> Here we examined whether a defect in DNA topoisomerase II activity could also be implicated. We were unable to detect activity of type II enzymes in the crude cytosol extracts by catenation

reactions in the presence of ATP (data not shown). This might have been due to low activity of DNA topoisomerase II or interference from excess DNA topoisomerase I activity. However, we were able to get some indication by indirect means of whether the enzyme is affected by the mutation. Three pieces of evidence suggest that it is not. First, DNA synthesis in ts20 cells do not exhibit enhanced sensitivity to novobiocin under restrictive conditions. Novobiocin inhibits DNA topoisomerase II activity in prokaryotes<sup>(7)</sup> and eukaryotes.<sup>(9,14)</sup> The mutant tsA1S9 in which the defective protein is required for the activity of DNA topoisomerase II has enhanced sensitivity to killing by novobiocin.<sup>(15,16)</sup> Second, inhibition of polyomavirus DNA synthesis in mutant cells at 33°C by novobiocin resulted in the accumulation of replicative intermediates. Analysis of polyomavirus DNA synthesized in vitro at 39°C reveals an accumulation of topoisomers migrating between form I and form II<sup>(2,3)</sup>. Thus, the effect of the drug, a topoisomerase II inhibitor, was different from the mutation. Third, the mutation did not alter cell chromatin conformation or the supercoiled density of mature virus DNA. Decreased DNA topoisomerase II activity should have affected both since changes in the superhelicity of cell chromatin and virus DNA can be detected when DNA synthesis is inhibited by novobiocin<sup>(9,10)</sup> or by the mutation in tsA1S9<sup>(15,16)</sup>. Overall, these results provide strong evidence that the mutation in ts20 does not affect DNA topoisomerase II.

#### Acknowledgements

This original research work was supported by grants from the Medical Research Council of Canada, and the National Natural Science Foundation of China, grant number 3860324.

#### References

1. Zeng GC, et al. Characterization of a ts mutant of Balb/3T3 cells and correction of the defect by in vitro addition of extracts from wild-type cells. *Mol Cell Biol* 1984;4:1815.
2. Zeng GC, et al. further characterization of the phenotype of a DNA<sup>t<sup>s</sup></sup> Mutant of Balb/3T3 cells. *Exp Cell Res* 1985;160:184.
3. Zeng GC, et al. Defective DNA topoisomerase I activity in a DNA<sup>t<sup>s</sup></sup> mutant of Balb/3T3 cells. *Somat Cell Mol Genet* 1985;11:557.
4. Zeng GC, Recent studies on DNA topoisomerases. *Chinese Biochem J* 1986;2:1.
5. Tricoli V, et al. DNA topoisomerase I and II activities during cell proliferation and cell cycle in cultured mouse embryo fibroblasts. *Exp Cell Res* 1985;158:1.
6. Zeng GC, et al. A comparative study of the biological activity of DNA topoisomerase I. *Chinese Biochem. J* 1988,4(2).

7. Gellert M, et al. Novobiocin and coumermycin inhibit DNA supercoiling catalyzed by DNA gyrase. PNAS 1976, 73:4474
8. Mizuuchi K, et al. DNA gyrase: subunit structure and ATPase activity of the purified enzyme. PNAS 1978;75:5960.
9. Mattern MR, Painter B. Dependence of mammalian DNA replication on DNA supercoiling II. Effect of novobiocin on DNA synthesis in Chinese hamster ovary cells. Biochim Biophys Acta 1979;563:306
10. Edenberg HJ. Novobiocin inhibition of Simian virus 40 DNA replication. Nature 1980;286:529.
11. Sudin O, Varshavsky A. Terminal stages of SV40 DNA replication proceed via multiply intertwined catenated dimer. Cell 1981;21:103.
12. Hirt B. Selective extraction of polyoma DNA from infected mouse cell culture. J Mol Biol 1967;26:365.
13. Cook PR, Brazell IA. Supercoils in human DNA. J Cell Sci 1975;19:261.
14. Miller KG, et al. A homogeneous type II DNA topoisomerase from HeLa cell nuclei. J Biol Chem 1981;256:9334.
15. Colwill RW, Sheinin R. Novobiocin sensitivity and chromatin conformation in wild-type and temperature-sensitive mouse L cells. Can J Biochem 1982;60:195.
16. Colwill RW, Sheinin R. TsA1S9 locus in mouse L cells may encode a novobiocin binding protein that is required for DNA topoisomerase II activity. PNAS 1983;80:4644.
17. Gourlie BB, et al. Poliovirus minichromosomes: A soluble in vitro replication system. J Virol 1981;38:805.

/12232

Rapid Detection of Heat-Labile E.coli Enterotoxin by Immune Hemolysis

40081061a Beijing WEISHENGWUXUE TONGBAO [MICROBIOLOGY] in Chinese  
Vol 15 No 1, Feb 88 pp 22-24

[Article by Li Shuqin [2621 3219 3830], Beijing Basic Medical Institute  
of Military Medical Academy]

[Excerpts] The heat-labile toxin, heat-stable toxin or both heat-labile and heat-stable toxins-producing E.coli are important dysentery-causing bacteria. Many methods have been developed to detect the pathogens, all of which are time-consuming and costly. In this article, an improved Passive Immune Hemolysis (PIH) was conducted to compare the results performed under different culture media, anti-cholera toxin serum (CT), and anti-heat-labile toxin (LT) serum. The results demonstrated that the improved method is fast, easy, sensitive, and specific after testing on 236 strains human-origin and 24 strains swine-origin E.coli.

/12223

Effect of Light Rare Earth Nitrates on Growth of Enteric Bacteria

40081061b Beijing WEISHENGWUXUE TONGBAO [MICROBIOLOGY] in Chinese  
Vol 15 No 1, Feb 88 pp 24-27

[Article by Xu Shuxian [1776 2579 7359], Institute of Military Medicine,  
Shijiazhuang [4258 1367 8369], Beijing Military Region]

[Excerpts] Although research has been conducted on light rare earth nitrate application in the field of microbiology in recent years, no reports have been published. In order to screen a culture medium capable of accelerating bacteria growth, light rare earth nitrate was added to culture enteric bacteria to study optimal concentration for bacterial growth. The enteric bacteria tested were: 4 strains *Shigella* Castellani et Chalmers; 3 strains *Salmonella* Lignieres; 3 strains *Escherichia* Castellani et Chalmers; 2 strains *Bacterium alcaligenes*; 1 strain *Bacterium aerogenes* (Kruse) Chester; 1 strain *Citrobacter freundii* (Braak) Werkman et Gillen; 2 strains *Proteus* Hauser; 1 strain *Proteus vulgaris* Hauser; 1 strain *Vibrio aquatilis* Gunther; 1 strain *Pseudomonas aeruginosa* (Schroeter) Migula. The results indicated that meat broth culture media containing 1 mg/ml crude light rare earth nitrate is the optimal concentration to stimulate growth of 16 strains of shigella, salmonella, and *E.coli* bacteria without being affected by quantity of inoculated bacteria, and cultured time (within 24 hrs.), but no effect found to the 3 strains of proteus vulgaris, vibrio aquatilis, and pseudomonas aeruginosa. The effective concentration of the rare earth nitrate to stimulate bacterial growth was 0.2-1.4 mg/ml, growth was inhibited with the increase of the concentrations.

/12223

Preliminary Study of Relationship Between Shigella Dysenteriae Coccus-Type and Tolerability Type

40081061c Beijing WEISHENGWUXUE TONGBAO [MICROBIOLOGY] in Chinese  
Vol 15 No 1, Feb 88 pp 30-31

[Article by Pei Biao [5952 2871], Peng Junfu [1756 0193 3940], Zue Xuelan [1563 1331 5695], Sanitation and Antiepidemic Station, Funing Xian [7079 1337 4905], Jiangsu]

[Excerpts] Due the the wide application of antibiotics and sulfonamides, the transmission of drug-resistant factor R plasmid causes continuous increase of shigella bacterial drug-resistant rates and mutation rates of multidrug-resistant strains. In this experiment, 111 strains (83 strains shigella flexneri, 27 strains shigella sonnei, 1 strain shigella boydii), and 12 antibiotics (kanamycin, amikacin, penicillin, gentamycin, erythromycin, neomycin, streptomycin, ampicillin, chloramphenicol, trimethoprim (sulfanilamide + TMP), tetracycline, cephalosporin) were tested. The results indicated that the wider the bacterial drug-resistant spectra, the higher the R plasmid diversion rates, therefore, the smaller the curability of antibiotics and the greater the drug-resistant bacterial population in the shigella dysenteriae, the 111 strains shigella dysenteriae have not only wide drug-resistant spectra (79.28 % resistant to more than 6 antibiotics), but also high multidrug-resistant frequency, and shigella flexneri has the highest multidrug-resistant rate among the three strains tested.

/12223

Isolation of Pathogenic L-Type Bacteria

40081061d Beijing WEISHENGWUXUE TONGBAO [MICROBIOLOGY] in Chinese  
Vol 15 No 1, Feb 88 pp 32, 48

[Article by Li Jinbao [2621 6651 1405], People's Hospital, Huaibin Xian  
[3232 3453 4905], Henan Province]

[Summary] The defective-cell-wall deformed bacteria by long-term intake  
of antibiotics are called L-type bacteria, 14 kinds of L-type bacteria  
including 9 Staphylococcus aureus, 3 E.coli, 2 Proteus Hauser, were  
isolated and were tested penicillin resistant, chloromycin and  
gentamycin resistant.

/12223

## BRITHOLITE-(Y) DISCOVERED IN CHINA

40090079a Guizhou KUANGWU XUEBAO [ACTA MINERALOGICA SINICA] in Chinese Vol 8 No 1, Mar 88 pp 19-24

[English abstract of article by Song Chunliu [1345 2504 2692], et al., of the Geological Survey Team No 3, Henan Geological Bureau, Nanyang; Zhang Jianhong [1728 1696 3163] of the University of Geology of China, Beijing]

[Text] Britholite-(Y) occurs in a rare metal-bearing granite in Henan Province, and has been discovered for the first time in China. The mineral is a silicate mineral with an apatite-type structure. It is creamy, rose and brown, with a measured specific gravity of 4.35.  $\omega = 1.784$ ,  $\epsilon - \omega = 0.007$ . As determined by electron microprobe, its formula is  $(Y_{3.17}Ca_{1.56}Dy_{0.22})((Si_{0.29}P_{0.83})O_4)_3(OH,F)$ . Space group:  $P6_3/m$ ,  $a = 9.426 \pm 0.008$ ,  $c = 6.806 \pm 0.007$  Å. The strongest lines in the powder diffraction pattern are 2.81 (10), 2.76 (8), 2.72 (7), 1.935 (6), 1.834 (6), 1.445 (6), 1.245 (5) and 1.102 (7). Infrared spectral analysis shows that it has strong absorption bands at 3450 and 940  $cm^{-1}$ , and moderate absorption bands at 570, 520 and 290  $cm^{-1}$ . The replacement mechanism among cations, anions and extra anions in the mineral species with an apatite-type structure are also discussed in this paper.

9717

STRUCTURAL, CHEMICAL CHARACTERISTICS OF NATURALLY-OCCURRING URANIUM OXIDES  
IN CHINA

40090079b Guizhou KUANGWU XUEBAO [ACTA MINERALOGICA SINICA] in Chinese Vol 8  
No 1, Mar 88 pp 72-80

[English abstract of article by Cai Genqing [5591 2704 1987], et al., of the  
Institute of Uranium Geology, Beijing]

[Text] All naturally-occurring uranium oxides found in China constitute a successive evolution series, from  $UO_{2.03}$  to  $UO_{2.85}$ , and possess a cubic structure of the fluorite model of  $UO_2$  ( $UO_{1.75}$ - $UO_{2.30}$ ). That is to say, variations in the O/U ratio of uranium oxides do not result in corresponding changes in the structural phase. However, their physical characteristics will change with their chemical composition, especially their O/U ratios. Their spectral characteristics (infrared absorption spectra, differential thermal spectra, etc.) show the same tendency as their physical characteristics. The conflict between chemical composition and structural phase is believed to be ascribed to hexa-valence  $(U)^{6+}$ , which is neither incorporated into the crystal lattice nor exists in the form of hexagonal and orthorhombic phases, but exists as  $UO_2^{2+}$  or  $(UO_3 \cdot nH_2O)$  in the crystal lattice. The amounts of  $(UO_2)^{2+}$  and  $(UO_3 \cdot nH_2O)$  incorporated in naturally-occurring uranium oxides have a great bearing on the geological setting during their formation, especially the O fugacity and S fugacity of the system during precipitation, which determines not only the properties of the uranium oxides formed, but also the variation in their O/U ratios. Pitchblende is a mixture of  $UO_2$ ,  $(UO_2)^{2+}$  and  $(UO_3 \cdot nH_2O)$ . Therefore, the variation in the O/U ratio of the minerals will not lead to their phase transformation.

9717

## New Battlefield-Hardened Computer Hardware

40080070a Beijing JISUANJI SHIJIE [CHINA COMPUTERWORLD] in Chinese 20 Jan 88  
p 2

[Article by Xuan [1357]: "Battlefield-Hardened Diskette Drive, Tape Drive and Head Developed by China"]

[Text] Three pieces of peripheral equipment suitable for use under harsh field conditions have been developed by Institute 706 of the Ministry of Astronautics Industry and they were recently certified by the ministry. Experts believe that their introduction meets the need in China. They are: the Model FD5222-R reinforced diskette drive, reinforced magnetic tape drive (SCS-880R) and Model F96 double-sided floppy disk head.

A battlefield-hardened diskette drive is not available in China. Other countries are banning the shipment of this equipment to China. Most of the components of this drive are manufactured in China and a standard circuit board is used. The unit was tested by experts and put to work with a DPS-6 computer. It was found to be stable and reliable and comparable to similar products made in other countries. It provides dust protection and interference resistance, and also dissipates heat well.

The streaming tape drive is an ideal backup for the Winchester disk drive which has received more attention in recent years. The Model SCS-880R was tested by experts and found to be well designed. It has a compact internal structure, good seal and high structural rigidity. The tape path is simple. The circuit is comprised of small boards. A portion of the circuitry uses heat sinks to dissipate heat. It is suitable for use in a tank.

The Model F96 double-sided floppy disk head also passed the certification. The head is made of a ferrite ceramic structure. All components are made in China. It was rigorously tested based on the requirements for a reinforced diskette drive and the EIAJ class 1 standard in Japan. After putting it to use in a Model FD5222-R reinforced diskette drive and a CDC Model 940PT diskette drive, it was found to be stable and reliable. It is compatible with similar foreign products (Sankyo). Experts believe that this is the first 96TPI head successfully developed in China and they feel that it can be batch produced.

12553/6091

Zhonghuan, Changjiang Learning Computers Debut

40080070b Beijing JISUANJI SHIJIE [CHINA COMPUTERWORLD] in Chinese 20 Jan 88  
p 9

[Article by Mu Gong [4476 1872]: "Zhonghuan Learning Computers Pass Evaluation"]

[Text] The Zhonghuan series of learning computers developed by Tianjin Radio Plant No 2 is a key project sponsored by the Science Committee of Tianjin. It includes Models ZH01, 02 and 03. They passed design review a few days ago and will be put in production soon.

The Zhonghuan ZH01 and 03 learning computers belong to the Zhonghua series of learning computers, using a 6502 CPU. The ZH01 is a simple version without a disk drive interface. Instead, it uses a cassette as external storage. It has a standard 53-key standard ASCII keyboard and a printer interface. It can be connected to a monitor and it has an RF modulator for connection to a TV set. In addition, it has a standard Chinese-character system on cassette. It is compatible with the Apple II computer and a large number of learning programs, games and recreation programs for Apple II have been converted for use on this computer. Furthermore, music software programs and the LOGO language have been developed. The computer costs approximately 650 yuan. It is suitable for teaching in elementary and secondary schools. The ZH03 computer is Apple compatible. It has 320 K ROM, 64 K RAM and two floppy disk drives. In addition to a monitor, it is equipped with an RF modulator to be connected to a black-and-white or color TV set. It uses a standard 69-key ASCII keyboard. The mother board has a printer interface and a piano keyboard interface. Furthermore, it is capable of handling graphics. In addition to having a second-level Chinese character database and the standard Chinese-character matrix database, it can use a compressed Chinese-character database which is a low-cost feature. The ZH03 is a very powerful learning computer which is also a general-purpose microcomputer.

The ZH02 uses a Z80A as the CPU and it operates at 4 MHz. It has 48 K RAM and 48 K ROM and has a compressed Chinese-character database and an optical pen interface. A cassette is used for external storage. It is not only suited for teaching in elementary and secondary schools but also for process control.

Shanghai Microcomputer Plant of Changjiang Computer Corporation introduced the Changjiang 1 Zhonghua learning computer which is suitable for computer education in elementary and secondary schools and for intellectual development at home. The computer uses a 6502 as the CPU. A basic unit includes the computer, display and printer. It has full functionality at a low cost. A high proportion of the components, 65 percent, is made in China. More than 2,000 units have been sold to date.

12553/6091

## Large-Capacity Disk Technology, Technical Hurdles Outlined

40080070c Beijing JISUANJI SHIJIE [CHINA COMPUTERWORLD] in Chinese 20 Jan 88  
p 24

[Article by Gong Binliang [7895 3453 5328] and Zhang Yunpeng [1728 0061  
7720]: "Large-Capacity Disk Technology in China"]

[Excerpts] Current Status

The disk development effort began in the Sixth 5-Year Plan with the disk drive for the 665 computer. The capacity of the drive was 6 MB. After importing the 29 MB disk drive from Bulgaria, China successfully developed 29 MB, 50 MB and 58 MB drives. In 1986 a new 58 MB disk drive was developed in China for a new computer. The Institute of Computing of the Chinese Academy of Sciences developed a 200 MB system and successfully developed a servo track writing device. After the successful development of a 50 MB disk drive, Institute 15 of the Ministry of Electronics Industry and Northwest Institute of Telecommunications Engineering jointly developed a 100 MB drive and a servo surface writing device for the 100 MB drive. It successfully used the servo track location technique. The associated 100 MB disks were developed by Huadong Institute of Computers and Plant 4509.

Magnetic heads equivalent to that used on an IBM 3370 are being assembled at Shenzhen Magnetic Head Factory in a quantity of 500,000 per year. They are being sold overseas. Small Winchester drives have been in production on imported production lines at Plant 4507 in Huaihua, Plant 4509 in Hangzhou, Huangpu Instrument Plant in Shanghai and Fujian Magnetic Recording Equipment Plant to meet a portion of the market needs in China. Certain higher learning institutions such as Huazhong Institute of Engineering, Shanghai Jiaotong University and Northwest Institute of Telecommunications Engineering have considerable technical strength as potential backup for the magnetic disk industry in China.

### Major Technical Hurdles and Approach

The key components of a large capacity drive include the disk, head, main motor, motor drive for the high-speed access arm, lubricant and special chips (for read/write amplification and gate-array control). There are technical hurdles associated with these components. Whether the mechanical

and materials industries in China can support this effort needs to be investigated. Because China does not have a well-established base for the manufacture of printers, recorders, computers and computer peripherals, these hurdles are difficult to overcome.

The output value of disk drives is almost equal to those of VLSI, LSI and SI combined. They all belong to micron-level technology. The rate of development, complexity and difficulty are comparable. Specifically:

#### (1) Disk and Medium

The aluminum substrate must have ultra-high density. There should be absolutely no pores which require a special smelting technique.

Cobalt doped  $\gamma$ -Fe<sub>2</sub>O<sub>3</sub> is added to the medium. The coercive force H<sub>c</sub> is 600 oersted. Br reaches 1,000-2,000 gauss. After adding CrO<sub>2</sub>, H<sub>c</sub> becomes 700-1,500 oersted and Br 1,000-2,000 gauss. For a sputtered medium, H<sub>c</sub> is 1,500 oersted and Br 6,000-12,000 gauss. The difficulties are super-thin medium, corrosion resistance and high coercive force.

#### (2) Gap Between Disk and Head

The hurdle is in the dynamic and static measurement techniques for determining the consistency of the 0.2-micron gap of the Mn-Zn ferrite head.

The head float height is moving from 0.2 micron to 0.1 micron. To solve the 0.1-micron unformatted disk problem, the first issue to resolve is the dynamic measurement of the head gap. We have to design the optimal float surface and develop a manufacturing process for the float module. The head gap is limited by the mean free path of the air (0.06 micron).

The thin-film head requires thick-film deposition technology and magnetic-film deposition technology.

#### (3) Lubrication

To further reduce the float height of the head, the collision between the head and the disk is unavoidable. Hence, lubrication is an important factor affecting the life of new disks.

Two types of lubricants, liquids and solids, are used.

A liquid lubricant is usually a hydrocarbon compound. A solid lubricant is generally a layer of SiO<sub>2</sub> or carbon.

#### (4) Disk Drive Seal

The pressure inside and outside the case must be balanced to sustain atmospheric pressure and to prevent dust from entering the drive. The pressure difference should be less than 1 lb/in<sup>2</sup>. At 80 percent relative humidity, the head and the disk should not stick together. The seal must reduce drag and improve heat conduction.

## (5) Improvement of Transmission Rate

To improve the transmission rate it is necessary to speed up the response time of the access arm motor drive. The goal is 17-19 ms access time.

## (6) Application-Specific Chips (ASIC's)

This area requires the assistance of the Chinese microelectronics industry in designing and developing ASIC's for read, write and control.

The following measures must be taken to overcome these technical hurdles.

Strengthen the fundamental research on the technology associated with the disk drive, such as head float theory, float height control technique, high-density head and recording medium, high-efficiency coding and error correction, high speed precision location technique, microelectronic control technology and the development of key electrical components.

High-capacity disk technology reflects the technology of the generation. It is no less difficult than that of the integrated circuit. The amount invested in this area by the Chinese Government is less than one-tenth of that in IC's. Together with the mainframe computer and VLSI, it is a cornerstone of the Chinese computer industry. We must increase the investment proportion in order to produce it in quantity.

Let us focus on medium-capacity disks which are upward and downward compatible to meet the needs of large computers and microcomputers. In particular, we must concentrate on producing only a few models which have a wide coverage. Medium-capacity disks are relatively standardized. In addition, the OEM market is highly competitive which will help China to get technical and key component support from other countries.

The density of the coated recording medium has not reached its limit. The recording density of the Mn-Zn ferrite head still has some untapped potential. Its cost performance ratio is acceptable. China should build a special plant to meet domestic needs and to export to other countries. These areas are well established in China. Substantial savings can be realized when we invest in them.

The current demand in China cannot support a disk-drive industry. Based on user psychology, it is easier to develop a domestic market for a product marked for export. China actually needs all the information processing equipment. Therefore, both domestic and foreign markets must be used in determining the scale of the plant.

Lateral cooperation should be encouraged to create the proper situation for development of high-capacity disks.

Under the current situation, there is no capital, no manpower and no technology. The optimal development approach is to coordinate the industry to create a mutually dependent entity where every organization specializes in a

certain area. In this new setting, research and production are integrated into one organization.

The "tax break" policy of the State Council should be implemented to improve the cost performance ratio to allow domestic products to compete with foreign products. Export should be encouraged. The tax abatement from export goods should be set aside for expansion.

A coordination unit must be established to hold meetings periodically.

12553/6091

## Problems in R&amp;D, Production of Hard-Disk Drives Addressed

40080070d Beijing JISUANJI SHIJIE [CHINA COMPUTERWORLD] in Chinese 20 Jan 88  
p 25

[Article by Huang Xuchen [7806 2485 2525] of China Magnetic Recording Equipment Corporation: "Problems Associated With the Research, Development and Production of Hard-Disk Drives in China"]

[Text] Recently, the Planning Office of the Shanghai Economic Zone conducted a survey on the conversion to production of microcomputers and their peripheral accessories in China. Through on-site observation and various meetings, we felt that the hard-disk-drive industry has made some progress after the technology import and construction over the past several years. However, we also felt common problems such as long production cycle, slow construction speed, low production capacity and poor competitiveness in the marketplace.

In China, the importance of the disk drive in computer development is recognized. In order to accelerate the growth of the disk-drive industry, the Chinese Government invested a great deal of manpower, materials and money to build and modify institutes and plants involved in the R&D and production of disk drives. In some institutions of higher learning, a special field in this area is established. A preliminary disk-drive industrial system consisting of research, teaching, development and production. We successfully developed the 29 MB movable disk drive, 6 MB and 24 MB cassette drives, 5.25-inch 10 MB and 20 MB Winchester drives, and 14-inch removable 200 MB drive. Some of the products can be produced in small batches.

Especially in recent years, advanced equipment, test instruments and complete sets of technical documents have been brought into China. After going through the process of "import, digest and absorb," a group of key technical personnel have been trained to enhance the ability to develop products in China. This is a foundation for developing premium disk drives and for raising the ability to manufacture them in China.

Through "import, digest, absorb," we controlled several key technologies:

1. Clean environment for the production of Winchester drives--a class 10,000 to 100 clean room with monitoring instruments has been obtained.

2. Static prevention in the production of Winchester drives--a set of anti-static equipment and monitoring devices has been obtained.
3. Servo read/write technique--ability to develop servo read/write equipment in China has been obtained.
4. Track error formatting--we are in the process of "digesting and absorbing" track error formatting with the 8-inch Winchester disk. On this basis, we are developing the equipment for track error formatting with 5.25-inch Winchester drives.
5. HDA (head disk assembly) sealing technique and equipment.
6. Technique and equipment for semi-automatic positioning and insertion of components.
7. Wave soldering of printed circuit boards and on-line pc board testing technology and equipment.
8. Quality assurance from product development to production.

Based on the situation described above, China has the ability to develop its own hard-disk drives. However, a disk drive is a capital and technology intensive product which involves magnetism, optics, electrical engineering, chemical engineering and precision machining. The industrial base in these areas is very weak in China. Therefore, in terms of variety, quality, compatibility and production capacity, China is falling far behind the rest of the world. To accelerate the growth of the disk drive industry, the author suggests:

1. We must address the speed of construction when we bring in a project. A disk drive is a high-technology product which becomes obsolete fast. The key to profitability is the speed of product development. Based on the survey done on several hard-disk manufacturers in the Shanghai Economic Zone, each project took 3 to 5 years from inception to completion. In other countries, hard-disk drives are turned over very rapidly. The market cycle is usually only 2-3 years. By the time the project is finished, the product is already obsolete.

2. With regard to the computer and peripherals market, the government should have control over the big picture and be flexible in fine details. The government should exercise control but not be too rigid; it should be flexible but not allow confusion to occur; it must be determined to control the import of complete systems in large quantity. Various computers that need to be imported must be rigorously reviewed and controlled to avoid abuse of the import system. Of course, to absolutely forbid import is deleterious to the domestic industry. However, unlimited import will impact the domestic market which will harm the young computer and peripherals industry in China. We know that Changcheng 0520CH is a good computer. It was a hot item in the first quarter of 1987. In the second quarter, the market was shrinking. In the third quarter, it was unmarketable. Since a price cut on 1 September,

the turnaround is still slow. The reason for this is that market control was relaxed. A large number of foreign-made microcomputers rushed into the marketplace. According to a survey, more than 40,000 microcomputers were imported either legally or illegally through various conduits in the first three quarters in 1987. This is an important reason why the market for Chinese-made microcomputers and peripheral equipment is shrinking. The government must use its economic leverage (such as pricing policy and complete accessory policy) and the necessary administrative intervention to persuade the user to drop the attitude that "the more advanced the better, regardless of the actual need." This will give new Chinese-made products a certain market life. Otherwise, once a product is developed it is obsolete; it will never be produced in quantity. Not only is the economic benefit poor but also the expansion of computer applications will be harmed.

3. The government should not expand new hard-disk-drive production facilities to repeatedly import assembly lines for low-price disk drives. We should speed up the technology reform of the current imported projects to build up the capability to produce a complete set of accessories in volume to improve the return on investment. In order to avoid the situation where "the product is obsolete once the project is finished," the government should concentrate its limited funds on accelerating technological reform of the current production lines for Winchester disk drives to make them adaptable to the production of premium disks. On the basis of "digest and absorb," key equipment on the production lines must be modified. Special equipment that cannot be resolved can be imported.

4. Let us recognize the significance of making disk drives in China in order to accelerate this process. In the second annual meeting on domestic production of computers, it was proposed that more than 60 percent of computers and peripherals was to be made in China in 1987 and 1988. The goal was to save over 40 percent of the foreign exchange. To accomplish this goal, there are many technical and policy problems. Let us use the 5.25-inch Winchester disk drive as an example: Most of the foreign exchange consumed in production is used on the VLSI, disk, head, main motor and position motor. They account for 76 percent of the CKD import cost. Hence, VLSI and the other four special parts are the key issues in the production of 5.25-inch Winchester disk drives in China. While VLSI and disks must be imported, heads and motors can be developed and produced in China. The government must make the proper arrangements based on priority and financial ability. Currently, disk-drive manufacturers generally indicate that the higher the degree of domestic production, the higher the manufacturing cost and the less competitive the product is. This shows that certain key accessories are technically feasible. Nevertheless, there is not enough quantity to bring the cost down. To solve this problem, in addition to improving the quality and reducing the cost of the product, the government should adopt a policy of encouraging disk drives made of a high degree of domestically produced components. Otherwise, there is no incentive to manufacture disk drives in China.

5. The business must undergo a transition to open the overseas market. The low labor cost should be used to attract foreign disk-drive manufacturers to set up joint ventures or processing plants. We can thereby not only get some advanced equipment and learn new technology, but also can earn some hard currency. The disk manufacturers can gradually be independent of foreign exchange support by the government.

### New Software for Taiji 2220 Undergoes Evaluation

40080070e Beijing JISUANJI SHIJIE [CHINA COMPUTERWORLD] in Chinese 27 Jan 88  
p 2

[Article by Shao [6730]: "Graphics Support Software NCI-GKS for Taiji 2220 Passes Technical Evaluation"]

[Text] Northern Computer Institute Computer Graphics and Computer Vision Laboratory (NCI-CGCVL) successfully developed a kernel system NCI-GKS-2B-FOR for graphics. It passed technical evaluation in Beijing on 12 January. GKS is the first international standard in computer graphics; it was issued by ISO in 1985. The NCI-GKS developed by Northern Computer Institute fully complies with the specifications of ISO GKS 2B and with the supplemental regulations on Chinese characters in the GKS national standard. This is the first software to pass the rigorous GKS test. Its performance and functionality are comparable to those of similar foreign products developed in the mid-1980's. Because it also includes input/output of Chinese characters at levels 1 and 2 and has a Chinese menu, it is superior to other imported GKS software.

The successful development of NCI-GKS is a major breakthrough in microcomputer-supported graphics software in China. The system has a FORTRAN interface which can support a number of graphics monitors and plotters. In addition to the Taiji 2220 system, it can be used on all VAX compatible machines.

12553/6091

## COMPUTERS

### New Shenyang Microcomputers

40080102d Beijing DIANZI SHICHANG in Chinese 4 Feb 88 p 2

[Summary] The XY II-0314 microcomputer, manufactured by the Shenyang Computer Plant, underwent technical evaluation in November 1987. At a sales price of 4800 yuan apiece, 5000 sets will be turned out yearly. This model is the plant's improved version of the Apple II, with which it is completely compatible. It is designed for office and industrial data processing and can be used in schools for computer literacy. The model uses a 6502 microprocessor for its CPU and operates at a 1-MHz basic frequency. It has an 8-bit word length, an 8-line data bus, and a 16-line address bus, and comes with a color or monochrome monitor, two 5-1/4-inch diskette drives, and a CP-80 compatible printer. The software configuration is per the DOS 3.3CP operating system using BASIC, FORTRAN, PASCAL, and COBOL. The XY IIe-0314 microcomputer, made by Shenyang Computer's Plant No 2, underwent design finalization in November 1987. The plant can manufacture 2000 sets per year at a sales price of 5000 yuan each. This model is compatible with the Apple IIe, uses a 6502 IC for its CPU, has a 64K internal memory, and operates at a basic frequency of 1 MHz. Uses include industrial control, document processing, archives management, financial management, teaching, and research. The 12K ROM contains a monitor program and an APPLESOFT interpreter. The system comes with a 5-1/4-inch diskette drive, a color or monochrome monitor, a printer, and a tape drive. The software configuration includes DOS3.3, APPLESOFT, INTBASIC, the CP/II operating systems (MBASIC, GBASIV, COBOL-80, FORTRAN80, etc.), the PASCAL operating system, and MONITOR.

/12223

**First 32-Bit-CPU Workstation**

40080110a Beijing JISUANJI SHIJIE [CHINA COMPUTERWORLD] in Chinese  
2 Mar 88 p 1

[Summary] China's first independently developed 32-bit-CPU workstation system, with digital and analog circuit processing functions, underwent MEI evaluation in Shanghai on 7 January. This workstation, the "FD-1 Circuit System CAD Center," was developed by Fudan University's Electronic Engineering Department; it can be used for design of overall circuits (for TV broadcasting, instruments, etc.) and for analysis and optimized design of individual ICs. The analog circuit system functions include simulation, Monte Carlo statistical analysis and optimized design, tolerance analysis, and design centralization of component parameters, and is suitable for circuits of several hundred nodes. The digital circuit system, intended for circuits of under 5000 gates, can carry out logic simulation, timing simulation, and line simulation. The system host is the PC/XT, improved with the addition of the DSI-780 coprocessor board (NMC 68020 CPU, 16.67 MHz clock frequency, floating-point processor, and 1-4 MB internal memory). The system's operational capability is comparable to that of the VAX 780 superminicomputer. The FD-1 will soon be installed in television factories (such as Shanghai TV Plant No 1) and in instrument factories.

/12223

## COMPUTERS

### Automatic Chinese-Character Reading Machine

40080110b Beijing JISUANJI SHIJIE [CHINA COMPUTERWORLD] in Chinese  
2 Mar 88 11 p 1

[Summary] The automatic Chinese-character reading machine developed by the Computer & Systems Science Department of Tianjin's Nankai University and currently undergoing evaluation represents a major breakthrough in character-recognition technology. The system can not only recognize commercially printed books and magazines, but also generate computer documents, in national standard code. Its recognition speed for various fonts runs from 10 to 14 characters per second with a recognition rate of 99.8-99.9%. Using this system, the 300,000-character book A Compilation of the Laws and Regulations of the People's Republic of China was entered onto two 5-inch diskettes in only two-plus days. System hardware consists of an IBM-PC/XT microcomputer, a 300-pixels-per-inch graphical scanner, and an appropriate interface; the software packages are for character recognition, user programming, and user self-instruction.

/12223

## 5-1/4-Inch Diskette Drive

40080110c Beijing JISUANJI SHIJIE [CHINA COMPUTERWORLD] in Chinese  
2 Mar 88 p 1

[Summary] It has been learned at the MEI-supported design finalization of the ZPC-14 500K 5.25-inch diskette 2D drive that batch production of this domestically made product is planned within a year. This diskette drive is a critical component--up to now imported--in the Chinese-made Chang Cheng (Great Wall) 0520-series microcomputers. After several years of research and experimentation, the Electronics Institute of Guangdong Province developed the large-scale-integration control ASIC (application-specific integrated circuit) which is a key part of the drive; this has permitted an overall exchange-rate savings of 93%. In the past year, the institute has completed additional work on the diskette drive, a key project in the Seventh 5-Year Plan. The drive will go into production at the Hunan Jiannan Machinery Plant, the Beijing No 3 Factory of External Computer Facilities, the Suzhou Electronic Equipment Plant, and the Guangdong Shaoguan Computer Plant.

/12223

## COMPUTERS

### Domestically Made North Star AT

40080110d Beijing JISUANJI SHIJIE [CHINA COMPUTERWORLD] in Chinese  
2 Mar 88 p 2

[Summary] The domestically made North Star AT high-level Chinese transaction system developed by the Jiangsu Radio Plant recently underwent municipal-level evaluation in Nanjing. This 16-bit microcomputer is compatible with the IBM-PC/AT. In addition to preserving all the functions of that original computer, this system has its own features such as a Chinese-character operating system (Sinicized XENIX) and Chinese inputting technique, and can display and print the national standard GB2312-80 middle level (7,445) of Chinese characters. The system can also carry out Chinese-character processing of DOS 3.3 files and is compatible with CCDOS.

/12223

## GF-10/11 Array Processor Completed

40080110e Beijing JISUANJI SHIJIE [CHINA COMPUTERWORLD] in Chinese  
16 Mar 88 p 1

[Summary] The GF-10/11 functionally distributed array processor (AP) jointly developed by China University of Science & Technology and the Chinese Academy of Science's (CAS) Institute of Computing Technology--and jointly completed by the CAS Software Institute and the Xinjiang Physics Institute--underwent CAS-level accreditation last October 9-10 in Hefei, Anhui Province. The GF-10/11 consists of two parts: a system supervisor using M68000 microprocessors and an independently designed AP. The AP has a 32-bit word length, a 4.25-MHz clock frequency, a 2M (megabyte) main memory, a 4K auxiliary memory, a 16K list memory, a 160K control memory, and 84M disk storage. Its maximum operating speed of 8.5 megaflops is faster than that of the MicroVAX II--with respect to a representative applications program--by 1-2 levels of magnitude. The arithmetic banks contain 242 microprograms, expandable to 1024. Software includes a distributed operating system based on UNIXV.7, VECTRAN, and Vector Assembly Language. This system is especially appropriate for scientific computation in areas such as petroleum prospecting, image processing, and digital signal processing. The GF-10/11 is the low-end model in and the last model of the GF-10 series; the other two models, the GF-10/12 and GF-10/13, were completed in 1986. The GF-10/12's highest operating speed is 14 megaflops and uses software compatible with the GF-10/11. The GF-10/13 prototype AP has a 9.8-nanosecond clock cycle and a maximum operating speed of 200 megaflops.

/12223

High-Quality Chinese-Character Processing

40080110f Beijing JISUANJI SHIJIE [CHINA COMPUTERWORLD] in Chinese  
16 Mar 88 p 1

[Summary] The North Star AT CXENIX1.10 Chinese-character information processing system--a multiuser, multitask high-quality microcomputer operating system--has been jointly developed by the Jiangsu Radio Plant and Nanjing University. This improved implementation of AT&T's UNIX system for an AT computer has performance norms that are stronger than those of DOS, to which it is similar in many areas. The system, which can accommodate 10 terminals, displays 25 lines of characters using a 15x16 dot-matrix pattern. The CXENIX system has a maximum data storage of 64K. Software programs include a data file conversion program from dBASE III to the INFORMIX relational database.

/12223

Improved Supermicrocomputer

40080110g Beijing JISUANJI SHIJIE [CHINA COMPUTERWORLD] in Chinese  
16 Mar 88 p 2

[Summary] The Zhonghuan 0674 microcomputer series is the Tianjin Computer Plant's domestically made and improved version of the UV68 series of microcomputers. Newly Chinese-made boards include the TP I/O interface, the CP-32, CM-4096, and CC-1, critical parts of the 0674. Tianjin Computer is planning to convert the 0674 into the 0684 high-quality microcomputer which will incorporate a completely 32-bit CPU board using the 68020 chip; trial manufacture of the 0684 is now in the preparatory phase.

/12223

Programmable Controller Unveiled

40080110h Beijing JISUANJI SHIJIE [CHINA COMPUTERWORLD] in Chinese  
16 Mar 88 p 17

[Summary] The NK-40 programmable controller developed by the Guangzhou Nanyang Electrical Equipment Plant through an absorption of advanced foreign technology recently underwent accreditation in Guangzhou. The NK-40 uses trapezoidal graphic language programming; its basic unit has a 24-port input and a 16-port output. The system comes with 16 timers, 16 calculators, 192 auxiliary relays, and an 890-step memory. Functions include logical operation, timing tabulation, power-loss protection, and automatic internal fault detection. This system, which meets international standards of the early eighties, is intended for automatic control of single machines or a small-to-medium-size production lines in industries such as machinery, metallurgy, light manufacturing, and chemical engineering.

/12223

COMPUTERS

Interface for Secure Telecommunications

40080110i Beijing JISUANJI SHIJIE [CHINA COMPUTERWORLD] in Chinese  
16 Mar 88 p 19

[Text] A certain unit of the Second Artillery [i.e., Missile Forces] has recently developed an approximately book-size interface device to connect classified microcomputers with single-sideband transceivers. This interface, used for fast and reliable secure radio transmission of [printed] Chinese characters, has a high resistance to atmospheric interference and to fading.

/12223

## COMPUTERS

### Universal Microcomputer Structural Analyzer

40080110j Beijing GUANGMING RIBAO in Chinese 19 Mar 88 p 1

[Summary] It has been learned from the accreditation conference organized by the State Education Commission for the SAP84 microcomputer universal structural-analysis program that the microcomputer can now be used to assume major computational tasks! According to the technical specialists, the overall performance of this program, developed by a Beijing University Mechanics Department team led by Associate Professor Yuan Mingwu [5913 2494 2976] is at the worldwide state-of-the-art. This program has been applied by over 200 users in over 20 ministries, including civil engineering, water resources and electrical power, communications, and machinery building.

/12223

## COMPUTERS

### New Great Wall Microcomputers

40080110k Beijing RENMIN RIBAO [PEOPLE'S DAILY] (Overseas Edition)  
in Chinese 21 Apr 88 p 1

[Summary] Chang Cheng (Great Wall) Computer has recently put out a new-generation 32-bit supermicrocomputer system, the Chang Cheng 386, and four enhanced microcomputer systems. The independently developed CMGA Chinese-language enhanced color system and the CMGA Chinese-language monochrome-monitor system have improved character-processing and graphics capabilities.

/12223

## COMPUTERS

### TP-Series Microcomputers on World Market

400801101 Beijing RENMIN RIBAO [PEOPLE'S DAILY] (Overseas Edition) in Chinese 21 Apr 88 p 4

[Summary] The high-performance, low-cost TP-series microcomputers, widely used domestically in recent years in manufacturing, national defense, transportation, scientific research, education, and medical treatment, are now being marketed worldwide. This series, produced by Beijing Industrial University and exported in collaboration with two joint ventures set up in Hong Kong and Shekou--Guang Yuan [1639 0337] Electronic Technology Ltd. and Guang Hua [1639 5478] Electronic Technology Ltd.--is available in Southeast Asia, the FRG, Australia, and Hong Kong, where it has received unanimous praise. Economic returns are also notable: from June 1981 to June 1987, total output of all products was over 105,000, with sales reaching 120 million yuan. Of this amount, over 60 million yuan in taxes has been turned over to the government; the university has increased its income by 27 million yuan.

/12223

## BRIEFS

Computer Corp. Aims at International Market--In cooperation with the Yanbian Korean Autonomous Prefecture Scientific Research Institute in Jilin Province, the Beijing Xintong Computer Technology Corporation has developed a new product needed by international markets. The product is an IBM-XT, Korean-language DOS operating system. It enjoys good sales in South Korea, Japan, and the United States: through the end of last year, the product generated over US\$400,000 in remittances. Xintong is a civilian-run science and technology industrial corporation organized in 1984 with the help of the Chinese Academy of Sciences (CAS). The New Technology Development Bureau of CAS has determined that this operating system meets international standards. The Qianlima language is used to load 11,172 Korean characters into the computer after which Korean texts can be created through the keyboard. After the deputy director of the Academy of Sciences of the Democratic People's Republic of Korea visited China, he was pleased with the system, and invited Xintong to visit North Korea in order to exchange ideas. Because in many ways this system is superior to the Korean-language microcomputer system developed by the Japanese, Korean merchants in Hong Kong and Southeast Asia are now showing a willingness to be Xintong Corporation's agents. [Summary] [40080129a Beijing GUOJI SHANGBAO in Chinese 11 Feb 88 p 2] /6091

Distributed Database Unveiled at Wuhan--A general-purpose distributed database system, DDBASE, recently developed by the Fourth Communications Station of the Guangzhou Military Area, underwent certification a few days ago. This system integrates Ethernet and dBASE II, while preserving all the functions and operational features of the latter. In its file management, the system uses three directory formats: 1) a Global File, which can be accessed by each node in the system; 2) a Relational File, which can be accessed by some of the nodes in the system; and 3) a Local File, which can be accessed only by the nodes which created the file. The data file has an automatic restoration function and is highly secure: both the data file and the command file can be entered only through a password. The system takes specific encryption measures to guarantee the security of the data file. [Summary] [40080129b Beijing JISUANJI SHIJIE [CHINA COMPUTERWORLD] in Chinese No 7, 24 Feb 88 p 1] /6091

Multifunctional Speech Processing System--Institute 710 of the Ministry of Astronautics Industry has developed a Chinese-speech integrated processing system, the CSIPS2000, which was certified a few days ago. Utilizing

character-to-speech conversion, this system can read aloud and proofread an inputted computer manuscript, and also has Chinese-speech-recognition and telephone-answering functions. The CSIPS2000, which employs two Texas Instruments speech boards and a microcomputer, has a 9600 bps Chinese tone-regulator speech bank capable of producing over 1300 syllable-tones. [Summary] [40080129c Beijing JISUANJI SHIJIE [CHINA COMPUTERWORLD] in Chinese No 7, 24 Feb 88 p 1] /6091

1987 Computer Product Imports/Exports--It has been learned from Customs authorities that imports of computer products last year cost US\$459 million [all figures in U.S. dollars], while the total exchange value of computer product exports was only \$45 million, or about 1/10 that of the imports. Detailed figures of exports and the foreign exchange earned are as follows: 13,485,000 calculators, \$25,592,000; 1,567 16-bit-and-under computer systems, \$2,627,000; 70 16-bit-and-over computer systems, \$196,000; 203 complete CPU's, \$89,000; peripheral equipment (including keyboards, tape drives, plotters, card units, power sources, and magnetic cores), \$16,616,000. In terms of progress in the campaign for domestic production, imports of 16-bit-and-under computer systems were reduced almost 25 percent compared to the previous year. Imports of 16-bit-and-over computer systems increased over 18 percent. [Excerpts] [40080129d Beijing JISUANJI SHIJIE [CHINA COMPUTERWORLD] in Chinese No 7, 24 Feb 88 p 2] /6091

High-Speed Data Acquisition System--A new high-speed data acquisition system suitable for an IBM-PC/XT (or AT) has recently been developed by the CAS' Anhui Optical Machinery Institute. It has a 10M (megabyte) or 20M single-use continuous acquisition capacity via hard-disk storage, and an A/D conversion resolution of 12 bits. The data acquisition board uses high-speed CMOS chips to permit a sampling period for datastream acquisition and disk inputting on the order of 35 microseconds. Its fastest sampling period is about 6 microseconds. This system is primarily intended for use in an aircraft radiometer and is especially suited for continuous data-acquisition projects. [Summary] [40080129e Beijing JISUANJI SHIJIE [CHINA COMPUTERWORLD] in Chinese No 7, 24 Feb 88 p 15] /6091

'KIND' IC CAD System--China's first independently designed large-scale two-dimensional IC CAD system (the KIND system)--jointly developed in Beijing by Qinghua University, Fudan University, and eight other institutions--underwent accreditation on 29 February with the support of the State Economic Commission. The appearance of this high-performance system, some of whose software has reached the worldwide state-of-the-art, is a major step forward for domestic industrial production of IC's. This supermicrocomputer-based LSI CAD system is applicable to 8-micron to 3-micron technology, including logical simulation, circuit analysis, region-based design and verification, and test-code generation. It serves as a tool for design of MOS digital circuits, bipolar circuits, and various linear IC's. The system comes with 190 executable programs, 600,000 source programs, and 20M object code. Statistics show that use of KIND's interactive graphics editor is 4-5 times as efficient as manual design of chips, and use of the automatic design instrument can raise this to 10-20 times. Maximum design capacity is for semi-custom circuits of 1,200 gates and for fully custom circuits of up to

10,000 components (2,000 gates). Costing less than half that of the imported product, this system can be used with the HP9000, MicroVAX, Apollo DN3000, and Sun workstations. [Summary] [40080129f Beijing JISUANJI SHIJIE [CHINA COMPUTERWORLD] in Chinese No 9, 9 Mar 88 p 1] /6091

First Automatic Network Monitoring System--China's first on-line automatic communications-network fault monitoring system, the DJ-85, developed after over 2 years by the First Communications Station Technology Laboratory of the Jinan Military Area and now formally installed at the Area's Communications Hub, has passed certification. This computer-controlled technology, a major advance in automatization and modernization of long-distance communications, has received a state patent. It is designed for networks of 1,000 lines in the 2,600-li [1300-km] range, and is over 50 times as efficient as the traditional manual method of fault detection. [Summary] [40080129g Beijing JISUANJI SHIJIE [CHINA COMPUTERWORLD] in Chinese No 9, 9 Mar 88 p 1] /6091

Prototype Relational Knowledge Base Computer--The National Defense University of Science & Technology's Computer Institute, using Intel's 86-310 and four 8612 single-board computers, has developed China's first prototype relational knowledge base computer, which passed accreditation in Changsha on 10 February. Distinctive features are as follows: 1) A new type of unified search mechanism and high-efficiency data structure. 2) High speed--an average of 20 times as fast, per inquiry, as the GKD-PROLOG/RMX interpretation system. 3) High performance, expandability, user friendliness; it can be operated on dBASE III, and has expanded applications. This prototype, a valuable tool for theoretical research on new-generation computers, can support minicomputer knowledge-base management and expert systems. [Summary] [40080129h Beijing JISUANJI SHIJIE [CHINA COMPUTERWORLD] in Chinese No 11, 23 Mar 88 p 1] /6091

First Domestic Ethernet LAN System--The L300, China's first domestically manufactured microcomputer Ethernet system, jointly developed by MEI's Institute 6, Qinghua University, and Nanfang [Southern] Information Company, underwent ministry-level design-finalization accreditation in Beijing on 22 March. This completely Chinese-made local area network (LAN) system for over 10 microcomputers complies with the IEEE Ethernet standard 802.3, and is fully compatible with the U.S. company 3COM's Ethernet (Etherseries and 3+ net). It has received favorable user reviews from trials in the State Seismological Bureau's Office Automation System and in the Ministry of Water Resources and Electric Power's Communications Network System. Observers at the accreditation unanimously agreed that the system's performance meets international standards of the eighties for LAN's. It has been learned that MEI has arranged for immediate batch production of this product, long available only by import. [Summary] [40080129i Beijing JISUANJI SHIJIE [CHINA COMPUTERWORLD] in Chinese No 12, 30 Mar 88 p 1] /6091

Advanced Development/Parallel Processing System--At the end of last year, the China Software Technology Development Center unveiled its ATD-C25 development system/image parallel processing system for digital signals, which uses the Texas Instruments 32-bit signal processor chip TMS 320C25

(40MHz clock frequency). The ATD-C25 system can be implemented as a plug-in board for the XT/AT/386 models. As a development system, it uses ALD320C25-series software, version 4.0. The entire system's resources include a 32K fast programming area (35 nanoseconds), a 64K data area, a 68-chip hardware emulation interface, a bidirectional-register communications interface, and a hardware semiautomatic overflow monitor. [Summary] [40080129j Beijing JISUANJI SHIJIE [CHINA COMPUTERWORLD] in Chinese No 12, 30 Mar 88 p 1] /6091

Shanghai Software Lab Products--The Shanghai Computer Software Laboratory, recently established at the Shanghai Computing Institute, has now put out a line of products, including the following: 1) ESET (Expert System Environment), which permits one to express form from skeletal knowledge. The system's knowledge editor uses syntax to control and guide editing, with a menu format and multiple windows. ESET utilizes TurboPROLOG language implemented on an IBM PC, but is easily transplanted to other machines. It is especially suited for medical diagnosis, testing, and image processing. 2) LIDBSE, an expert system environment based on the LIDBS relational database. 3) A "General-Purpose Syntax-Controlled Editing and Execution Environment," which is an integrated program design environment. 4) A software comprehension support tool called GAUSS (General Automatic Program Graph Generating System), for structural analysis and generation of source programs in the C language. Intended for an IBM PC (XT or AT), GAUSS is easily transplanted to the MicroVAX-II and other systems. 5) "Execution Pascal," a high-level-language program design environment. 6) ERATO (Extensible Requirement Analysis Tools), an integrated environment that supports interactive information system development; it is run on a MicroVAX-II. [Summary] [40080129k Beijing JISUANJI SHIJIE [CHINA COMPUTERWORLD] in Chinese No 13, 6 Apr 88 p 2] /6091

Microcomputer Acceleration Board--Institute 23 of the Ministry of Astronautics Industry, a research institute working on high-level radar ground equipment, recently developed a new microcomputer acceleration board, the DSI68020. This high-integration, completely 32-bit single board device occupies an area slightly larger than that of two palms. Inserted into a commonly used microcomputer's slot, it can expand the computer's capacity by a factor of 4 and the operational speed by a factor of over 100, which can bring the speed up to 2MHz to 10MHz, in the range of a minicomputer or mid-size computer. This inexpensive device can be easily applied to microcomputers--of which there are 240,000 in China, according to statistics--to expand their power. [Summary] [400801291 Beijing BEIJING KE JI BAO [BEIJING SCIENCE & TECHNOLOGY NEWS] in Chinese 6 Apr 88 p 3] /6091

Achievements of High-Tech Development Co.--The Computing Institute New Technology Development Company, established 3 years ago by the Institute of Computing Technology of the Chinese Academy of Sciences, has realized economic returns of 91 million yuan over its lifetime. The Computing Institute is the first integrated facility for research on computer science and technology and has almost 1,000 personnel. Its New Technology Development Company, with 220 employees (80 percent in science and technology) carries out all phases of research and development, including trial manufacture, production, sales, and service. [Summary] [40080129m Beijing GUANGMING RIBAO in Chinese 17 Apr 88 p 1] /6091

## EARTH SCIENCES

### POLICY STUDY ON OFFSHORE POLLUTION

40081057a Beijing ZHONGGUO HUANJING BAO in Chinese 1 Mar 88 p 1

[Article by reporters Rao Beiya [7437 0554 0068], and Jiang Xia [3068 1115]]

[Summary] Two research projects in marine environmental protection-- "Forecast and Policy Study For Offshore Pollution by Year 2000" and "Survey of Land-Origin Pollutants in Coastal Areas" were recently completed by a research group including experts from the Transport Ministry, the Ministry of Agriculture, Animal Husbandry, and Fisheries, and the Ministry of Water Resources and Electric Power. Since March 1985, a team led by the State Environmental Protection Bureau has been studying inland-origin pollutants and offshore area pollution including harbors, merchant ships, fishing boats, naval vessels, platforms, and coastal construction areas. The results revealed that China's marine environment today is generally in good condition, but offshore areas have suffered various degrees of pollution with damage to the marine ecology being heavy in those areas adjacent to large cities, harbors, bays estuaries. In order to effectively control marine environmental pollution and to prevent deterioration of the marine ecology before 1990, and to basically solve the problems by 2000, the researchers pointed out that the following steps must be taken now:

- (1) Control of key pollutants and polluted areas near the shore;
- (2) Division of the functions of the water areas. Make water quality plans to conduct a more planned control of coastal pollution;
- (3) Develop self-cleansing capability of water areas;
- (4) Provide proper industrial layouts;
- (5) Implement control of total pollutant discharged;
- (6) Establish and tighten marine environmental forecasts and appraisal systems;
- (7) Tighten prevention and control of pollution in the ship-breaking industry;

- (8) Establish an emergency system to handle catastrophe;
- (9) Establish a sound administrative system to deal with marine pollution;
- (10) Emphasize research on pollution protection.

/9604

DETERMINATION OF TRACE ZIRCONIUM IN ROCKS, MINERALS CONTAINING RARE EARTHS,  
URANIUM, TITANIUM BY DERIVATIVE SPECTROPHOTOMETRY

40090077a Beijing YANKUANG CESHI [ROCK AND MINERAL ANALYSIS] in Chinese Vol 7  
No 1, Mar 88 pp 1-6

[English abstract of article by Wang Changfa [3769 7022 4099] of Tianjin  
Geological and Mineralogical Research Institute]

[Text] A new method has been developed to determine trace zirconium by derivative spectrophotometry. A zirconium-arsenazo III complex was formed in a perchloric acid medium. Using fourth-derivative and  $\Delta\lambda = 10$  nm, the apparent derivative molar absorption coefficient of this complex is  $4.19 \times 10^5 \cdot \text{L} \cdot \text{mol}^{-1} \cdot \text{cm}^{-1}$ , which is 2.57 times higher than that of ordinary spectrophotometry. The detection limit is  $0.016 \mu\text{g}/10$  ml zirconium. A linear calibration curve is obtained in the range of  $0-10 \mu\text{g}/10$  ml zirconium. This method has excellent selectivity and can be used to determine the ppm level of zirconium in ordinary rocks containing rare earths, uranium, thorium, titanium phosphate and fluoride without separation. It is characterized by its simple operation procedure, good reproducibility and high accuracy. It has been successfully applied to the determination of zirconium in various standard rock samples.

9717

SEPARATION OF HEAVY RARE-EARTH ELEMENTS BY THIN-LAYER CHROMATOGRAPHY

40090077b Beijing YANKUANG CESHI [ROCK AND MINERAL ANALYSIS] in Chinese Vol 7  
No 1, Mar 88 pp 10-14

[English abstract of article by Wang Jun [3769 0193], et al., of the Department  
of Chemistry, East China Teachers University; Zheng Jieheng [6774 0094 1854]  
of Shanghai Reagent Plant No 1]

[Text] Two thin-layer chromatographic methods are reported for the separation  
of heavy rare-earth elements. Silica gel, ammonium nitrate and CMC were used  
as the stationary phase, with di(2-ethylhexyl) phosphoric acid/isopropyl ether/  
ether/nitric acid (System I) (v/v 1:10:6:1.1) and mono(2-ethyl-hexyl) phos-  
phoric acid/isopropyl ether/ether/nitric acid (System II) (v/v 1:8:8:1.1) as  
developers. Using either System I or II, La, Sm, Eu, Gd, Tb, Dy, Ho, Er, Tm,  
Yb, Lu and Y can be separated from one another, although the separating  
efficiency of System II is better.

9717

## BRIEFS

RADIOACTIVE WASTE PLAN FORMULATED--Although no evidence has been found that nuclear industry development over the past 30 years has caused any noticeable effect on either public health or environmental safety, the potential hazard from increasing production of radioactive waste by increasing numbers of nuclear plants as a result of the shift from military production to economic production does exist. In order to prevent these problems, e.g., environmental pollution created by improper storage of radioactive wastes due to poor handling techniques, and to safeguard against potential hazards, the Ministry of Nuclear Industry launched a comprehensive study on radioactive waste problems in 1986. A planning team made up of nuclear experts, technicians and management personnel with specific expertise was organized to study nuclear management technology, from solidifying the highly radioactive liquid waste, handling medium and low radioactive liquid waste to treatment of high, medium, and low radioactive gaseous waste. From this study, a draft of a short-term (before the year 1990) and a mid-term (before the year 2000) nuclear waste control plan have been preliminarily formulated. [Summary] [40081057b Beijing ZHONGGUO HUANJING BAO in Chinese 23 Feb 88 p 1] /9604

## BRIEFS

Domestically Made Programmable Controller--A Chinese-made programmable controller with a high performance-to-cost ratio recently passed its technical assessment in Beijing and will be batch produced at the Chunshu Electronic Instrument Factory there. This model, the BCM-PIC, was jointly developed by the Beijing Municipal Computing Institute and the Chunshu Factory. It uses an 8085AH CPU, 6MHz basic frequency. User programming area in the internal memory is 4K, which can hold 2048 PIC (programmable instruction configuration) instructions. I/O ports vary from 40 to 352. This industrial control device meets the standards of foreign products as of the early eighties. A batch tried out for over 3 months at the Beijing General Gear Factory has increased productivity approximately 25 percent. [Summary] [40080128a Beijing JISUANJI SHIJIE [CHINA COMPUTERWORLD] in Chinese No 7, 24 Feb 88 p 2] /6091

Robot Vision System--The GKD-1 Robot Vision System developed by the National Defense University of Science & Technology's Automatic Control Department passed accreditation not long ago in Changsha. It consists of five basic parts: 1) a two-faceted inputting technique using a pickup camera and a scanner; 2) an image processing system, including a PC VISION board and an image monitor; 3) a computer control system, either an IBM PC/XT or a Chang Cheng [Great Wall] 0520; 4) an execution mechanism consisting of an RM501 robot and an improved electronic organ; and 5) a laser light source. Its functions include: 1) recognition and comprehension of simple part assembly drawings, and planning of robotic movement sequences; 2) recognition and position-fixing of components on a worktable via a two-dimensional vision system; 3) fixing of the three-dimensional orientation (all three coordinates) of geometrical shapes via a single-camera three-dimensional vision system; and 4) limited recognition of handwritten musical notation and control of the electronic organ in playing that music. With a recognition accuracy of 95 percent and a position-fixing accuracy of  $\pm 2$  mm, the GKD-1 can not only be a useful tool for laboratory research, but also can serve as the "eyes" for industrial and other robots. [Summary] [40080128b Beijing JISUANJI SHIJIE [CHINA COMPUTERWORLD] in Chinese No 12, 30 Mar 88 p 1] /6091

Error Analysis, Optimal Operational Area for Laser Ship-Model Tracking Instrument

40080134 Shanghai SHANGHAI JIAOTONG DAXUE XUEBAO [JOURNAL OF SHANGHAI JIAOTONG UNIVERSITY] Vol 22 No 2, Mar 88 pp 84-92

[Article by Xu Gaoyue [1776 7559 6885], Applied Physics Dept. Received 9 Jul 86]

[Abstract] The laser ship-model tracking instrument we have developed is an automatic laser measuring system for a ship's track and two-dimensional attitude. It uses two laser scanning goniometers and the triangulation method to obtain track and attitude data. The relationship between the random error inherent in the goniometric system and error in the position of the ship is analyzed through error formulas, and precise curves are derived for error analysis over a specified area. Finally, the question of optimal operational area is discussed. The results provide a foundation for more precise use of this instrument, which is superior to other similar domestic or foreign systems both in precision and in function.

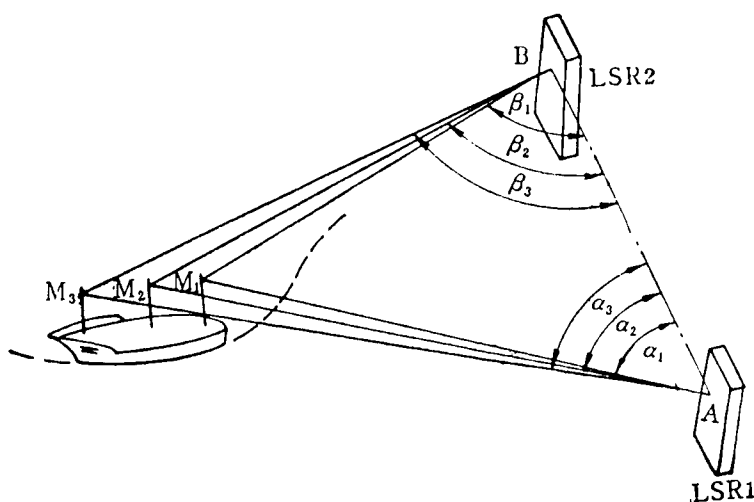

Schematic of basic operating principle

#### REFERENCES

1. Besteliankov [phonetic], V.B. Radio Navigation Goniometric Systems, National Defense Industries Publishing House (1964).
2. Xu Gaoyue, ZHONGGUO ZAOCHUAN [CHINA SHIPBUILDING], 3 (1986) 80.
3. Zhu Yajun [2612 0068 6511] et al., SHANGHAI JIAO DA KE JI [SHANGHAI JIAOTONG UNIVERSITY SCIENCE & TECHNOLOGY], 2 (1986) 64.

/9604

New Grating Sensor

40080102h Tianjin JISHU SHICHANG BAO [TECHNOLOGY MARKET NEWS] in Chinese  
17 Feb 88 p 1

[Text] A miniature circular grating coder-- a sensor widely used in numerically controlled machine tools, robotics, naval vessels, aviation, and measuring instruments--developed by the CAS's Nanjing Astronomical Instrument Factory recently underwent technical appraisal. This sensor has a broad frequency band, good stability under changes of temperature and power, a high resistance to interference, and a high rotation limit velocity, and provides full output information and a precise null-line position.

/12223

RADIATION OF DYE MIXTURES PUMPED BY N<sub>2</sub> LASER

40090083a Shanghai ZHONGGUO JIGUANG [CHINESE JOURNAL OF LASERS] in Chinese  
Vol 15 No 3, 20 Mar 88 pp 134-137

[English abstract of article by Lei Jie [7191 2638], et al., of the Department  
of Physics, Yunnan University, Kunming]

[Text] The emission spectra of four dye mixtures pumped by the N<sub>2</sub> laser are studied. These mixtures are rhodamine 6G + crestyl violet, rhodamine B + crestyl violet, rhodamine 6G + rhodamine B and rhodamine 6G + rhodamine B + crestyl violet. The energy transfer processes in the mixtures are discussed. It is shown that the broadening tuning range of dye lasers, the increase in laser efficiency of some dyes and dual wavelength laser oscillation in the dye mixtures are feasible.

9717

EXPERIMENTAL STUDY OF SELF-GENERATED MAGNETIC FIELD IN CORONA AREA OF LASER PLASMAS

40090083b Shanghai ZHONGGUO JIGUANG [CHINESE JOURNAL OF LASERS] in Chinese Vol 15 No 3, 20 Mar 88 pp 153-155, 137

[English abstract of article by Zhang Huihuang [4545 6540 3552], et al., of the Shanghai Institute of Optics and Fine Mechanics, Chinese Academy of Sciences]

[Text] The self-generated magnetic field in the corona area of laser plasmas has been measured using the Faraday-rotation method of a 630.3 nm probe beam. Experimental results prove that the "thermal force source" suggested theoretically by Colombant is one of the important sources of a self-generated magnetic field.

9717

COOPERATIVE EFFECTS OF NEAR-RESONANCE ELECTRONIC RAMAN SCATTERING IN Pb VAPOR

40090083c Shanghai ZHONGGUO JIGUANG [CHINESE JOURNAL OF LASERS] in Chinese  
Vol 15 No 3, 20 Mar 88 pp 170-173

[English abstract of article by Huo Yunsheng [7202 5366 3932], et al., of  
Shanghai Institute of Optics and Fine Mechanics, Chinese Academy of Sciences]

[Text] Cooperative effects have been observed in the near-resonance electronic Raman scattering experiments involving XeCl excimer laser pulses in Pb vapor. The Raman-radiation pulse shapes obtained by numerically solving the two-level Bloch-Maxwell equations were found to be qualitatively consistent with the experimental results.

9717

EXPERIMENTAL INVESTIGATION OF CAVITY CONFIGURATIONS FOR CVL PUMPED DYE LASERS

40090082a Shanghai ZHONGGUO JIGUANG [CHINESE JOURNAL OF LASERS] in Chinese  
Vol 15 No 4, 20 Apr 88 pp 193-196

[English abstract of article by Tang Chuanshun [0781 0278 5293], et al., of  
the Department of Physics, Zhejiang University, Hangzhou]

[Text] Four kinds of cavity configurations of dye lasers transversely pumped  
by high PRF CuBr lasers are investigated and their operating characteristics  
compared. The double prism expander with a Littrow mounted grating cavity  
is found to be the optimum. The linewidth achieved is 0.0012 nm in the  
598-640 nm range and the conversion efficiency is 7.5 percent. An amplified  
spontaneous emission of 1.5 percent and single longitudinal mode operation  
are obtained.

9717

BEAM DIVERGENCE OF COPPER VAPOR LASER VERSUS EFFICIENCY OF DYE LASER PUMPED WITH IT

40090082b Shanghai ZHONGGUO JIGUANG [CHINESE JOURNAL OF LASERS] in Chinese  
Vol 15 No 4, 20 Apr 88 pp 197-200

[English abstract of article by Liang Peihui [2733 1014 6540], et al., of  
Shanghai Institute of Optics and Fine Mechanics, Chinese Academy of Sciences]

[Text] Experimental results are presented which show that, at the pumping level of 5 W, when the beam divergence of a copper vapor laser is reduced from 8 mrad to 1 mrad, the output of the dye laser pumped with it will be doubled or greater. Further improvement of the divergence, however, will only result in a slight increase in the dye laser's efficiency. This conclusion is in good agreement with the simple analysis of geometric optics. Therefore, an injection locked unstable resonator is the best arrangement for the copper vapor laser as the pumping source for dye lasers.

9717

EXPANDING OF PULSE DURATION OF TWO-CHANNEL SYNCHRONOUS XeCl EXCIMER LASER

40090082c Shanghai ZHONGGUO JIGUANG [CHINESE JOURNAL OF LASERS] in Chinese  
Vol 15 No 4, 20 Apr 88 pp 204-206

[English abstract of article by Cao Hongru [2580 3163 1172], et al., of Anhui  
Institute of Optics and Fine Mechanics, Chinese Academy of Sciences, Hefei]

[Text] A new two-channel discharge pumped excimer laser is reported. Two sets of LC pulse forming were line-connected with the main discharge capacitors respectively and, controlled by a common spark gap, discharged to their own channels. A pulse duration of 60 ns from the XeCl excimer laser was obtained, which was operated at fine synchronism (jitter time  $\leq \pm 4$  ns). The energy of each laser beam was 120 mJ.

9717

ENERGY LEVELS, SPECTROSCOPIC CHARACTERISTICS OF BHA:Cr<sup>3+</sup> CRYSTALS

40090082d Shanghai ZHONGGUO JIGUANG [CHINESE JOURNAL OF LASERS] in Chinese  
Vol 15 No 4, 20 Apr 88 pp 250-252

[English abstract of article by Hu Zhiwei [5170 1807 0251], et al., of  
Shanghai Institute of Optics and Fine Mechanics, Chinese Academy of Sciences]

[Text] A new crystal, BeO:3Al<sub>2</sub>O<sub>3</sub>:Cr<sup>3+</sup>, grown by the Czochralski method, is reported. The absorption and fluorescence spectra at room temperature have been measured. Three sharp lines of the fluorescence spectrum are at 695, 692.5 and 691 nm. The <sup>4</sup>T<sub>2</sub> emission is from 700 to 900 nm. The crystal-field levels have been calculated according to the static electronic field model. Such parameters as the crystal field strength D<sub>q</sub>, Racach parameter B and C and ΔE were calculated to be 1663, 643, 3180 and 589 cm<sup>-1</sup>, respectively.

9717

## LASERS, SENSORS, OPTICS

### BRIEFS

NEW-GENERATION SYNTHETIC APERTURE RADAR--Beijing (Xinhua), 20 Apr--The new-generation synthetic aperture radar developed by China--a multiple polarization imagery synthetic aperture radar system with multiple surveying and mapping channels--underwent national-level accreditation today in Beijing. This synthetic aperture side-looking radar, a new model used for remote sensing of the environment and of natural resources, can provide excellent bearing, range, and resolving power, and captures images similar to optical photography. Unlike the typical radar, synthetic aperture radar uses a small constantly moving airborne radar antenna which effectively becomes a large antenna; through two-dimensional signal processing, it achieves excellent resolution. Currently only two [other] countries in the world--the United States and the FRG--can manufacture this kind of radar. Specialists at the accreditation feel that this radar system's development fills a domestic gap; its main performance norms have reached the worldwide state-of-the-art. [Text] [40080109 Beijing RENMIN RIBAO [PEOPLE'S DAILY] (Overseas Edition) in Chinese 21 Apr 88 p 4]

## MICROELECTRONICS

### 100-Kilowatt High-Frequency Transmitter

40080102k Beijing DIANZI SHICHANG in Chinese 25 Feb 88 p 1

[Summary] The 100,000-watt high-frequency transmitter developed by the Beijing Broadcasting Equipment Plant has received the State's Major Technological Installation award, signed and issued by Premier Li Peng. This apparatus, which provides a reliable power source for China's first electron-positron collider (see JPRS-CST-88-001, 14 Jan 88, p 1), combines eight 200-Hz continuous-wave 30-kw high-frequency transmitters, through separate electrical bridges, into two 100-kw linear power amplifiers. The controlled high-frequency power is sent to the main ring of the collider in order to accelerate the electrons and to make up for power lost to synchrotron photoradiation depletion. This equipment has reached the international state-of-the-art and costs less than half that of the imported product. This will not only generate great savings on foreign exchange, but will also improve overall standards in the electronics industry.

/12223

Picosecond Time-Resolved Detection of Plasma Formation and Phase Transitions in Silicon

40090089 Beijing BANDAOTI XUEBAO [CHINESE JOURNAL OF SEMICONDUCTORS] in Chinese Vol 9 No 2, Mar 88 pp 163-168

[English abstract of article by Ma Haiming et al., Department of Physics, Fudan University, Shanghai]

[Text] Picosecond time-resolved reflectivity and transmission changes have been measured to study the electron-hole plasma formation and phase transitions in silicon induced by 0.53-micron 30-ps laser pulses. The experimental results provide evidence of ultrafast energy transfer from the laser pulse to the lattice and of lattice heating and phase transition within 30 ps. It has been pointed out that Auger recombination can limit the increment of electron-hole plasma density. Some electron-hole plasma parameters under high excitation are also deduced from the experimental data. (Received 6 Dec 86.)

Research on Application of Double Gettering Technique for CCD Fabrication and Its Increased Gettering Effect

40090089 Beijing BANDAOTI XUEBAO [CHINESE JOURNAL OF SEMICONDUCTORS] in Chinese Vol 9 No 2, Mar 88 pp 169-174

[English abstract of article by Zhou Shiren et al., Harbin Institute of Technology; Mai Zhenhong and Dai Daoyang, Institute of Physics, CAS, Beijing; and Yang Jiade and Chen Muzhang, Chongqing Research Institute of Photoelectric Technology]

[Text] The application of double gettering technique in the fabrication of CCD is introduced and its general applicability is proved. Based on observation of the etched defect patterns and study of the microimage by electron microscopy, it is shown that the gettering effect of the phosphorus is greater than that of the defects. This result is also proved by estimation using the ion pair model. In comparison to defect gettering only, therefore, the double gettering process is a technique which can greatly increase the gettering effect. (Received 23 Dec 86.)

## Investigation of UV-VB-IR Spectra for Amorphous Semiconductor Superlattices

40090089 Beijing BANDAOTI XUEBAO [CHINESE JOURNAL OF SEMICONDUCTORS] in Chinese Vol 9 No 2, Mar 88 pp 181-188

[English abstract of article by Mao Guomin et al., Department of Physics and Solid State Physics Institute, Nanjing University]

[Text] The successful creation of amorphous semiconductor superlattices of a-Si:H/a-SiN<sub>x</sub>:H films consisting of 28-102 periods of 10-200 Å thick a-Si:H and 60 Å a-SiN<sub>x</sub>:H by periodic alternation of the plasma gas mixture in a single reaction chamber of a plasma deposition system is reported. The results of TEM and XPS show the smooth and sharp boundaries between the layers. The vibration modes of (Si-H)N stretchbonds and extra hydrogen bonded at the interface are discovered by analyzing the fine structure of (Si-H) stretch mode in wavenumbers 2400-1800 cm<sup>-1</sup>. The results of investigation of UV-VB spectra indicate that the shift of optical energy gap E<sub>g</sub><sup>opt</sup> in a-Si:H/a-SiN<sub>x</sub>:H superlattices is induced by a quantum well effect. (Received 19 Jan 87.)

## Low-Temperature Ohmic Contacts on High-Resistivity Silicon

40090089 Beijing BANDAOTI XUEBAO [CHINESE JOURNAL OF SEMICONDUCTORS] in Chinese Vol 9 No 2, Mar 88 pp 208-210

[English abstract of article by Li Gang et al., Semiconductor Materials Institute, Zhejiang University, Hangzhou]

[Text] A method employing laser-induced diffusion is developed to make low-temperature ohmic contacts (77-300K) on high-resistivity P-type silicon (room-temperature resistivity greater than 15,000 ohm-cm). The effect of laser parameters on the low-temperature specific contact resistance of ohmic contacts is discussed in combination with the theoretical calculation of the laser-induced regions. Two different welding techniques are compared. (Received 7 Jan 87.)

## Cross-Sectional TEM Observation of Non-Uniformity in Multiple Quantum Well Structures

40090089 Beijing BANDAOTI XUEBAO [CHINESE JOURNAL OF SEMICONDUCTORS] in Chinese Vol 9 No 2, Mar 88 pp 211-212

[English abstract of article by Fan Tiwen, Institute of Semiconductors, CAS; Beijing Laboratory of Electron Microscopy, CAS, Beijing]

[Text] Cross-sectional TEM observation of GaAs-Al<sub>x</sub>Ca<sub>1-x</sub>As multiple quantum well structures grown by molecular beam epitaxy is carried out. Results show that the broadened emission band of photoluminescence is probably due to non-uniform size of the wells. (Received 19 Jan 87.)

### High-Quality MBE GaAs-AlGaAs Quantum Well Structures

40090089 Beijing BANDAOTI XUEBAO [CHINESE JOURNAL OF SEMICONDUCTORS] in Chinese  
Vol 9 No 2, Mar 88 pp 213-216

[English abstract of article by Liang Jiben et al., Institute of Semiconductors, CAS]

[Text] High-quality GaAs-AlGaAs QW structures are prepared by a homemade MBE system. The line width of the PL spectrum of  $n=1$  electron-heavy hole free exciton recombination is very narrow and its full width at half maximum (FWHM) is only 1.2meV for well width 141Å at 10.5K. This indicates that the fluctuation of well width and flatness of interface is less than one monolayer. The emission is kept excitonic from low temperature to room temperature. (Received 22 Dec 86.)

### Modifying the SiO<sub>2</sub> Surface State

40090089 Beijing BANDAOTI XUEBAO [CHINESE JOURNAL OF SEMICONDUCTORS] in Chinese  
Vol 9 No 2, Mar 88 pp 221-223

[English abstract of article by Han Jieping, Wang Peida, et al., Microelectronics Research and Development Center, CAS, Beijing; Institute of Semiconductors, CAS]

[Text] A novel technique for modifying the SiO<sub>2</sub> surface state is presented. After the SiO<sub>2</sub> surface is bombarded by electrons of a certain energy, the variation in etching rate is observed. The rate for unbombarded SiO<sub>2</sub> is about 700-1000 Å/min. However, no obvious etching is observed for bombarded samples. (Received 31 Aug 87.)

## SUPERCONDUCTIVITY

### New Superconducting Oxide Thin Film

40080102f Shanghai WEN HUIBAO in Chinese 12 Feb 88 p 3

[Excerpts] Beijing University recently developed a new type of superconducting oxide thin film, containing no rare-earth elements, that is claimed to be so far unreported in the world. Composed of bismuth, strontium, calcium, copper, and oxygen, this film has a zero-resistance temperature of 73K. Beijing University previously has developed new superconducting oxide materials consisting of similar elements and has made initial modeling studies of the crystal structure of these materials.

/12223

## SUPERCONDUCTIVITY ABOVE 70 K IN Ba-La-Cu OXIDE

40090075a Beijing DIWEN WULI XUEBAO [CHINESE JOURNAL OF LOW TEMPERATURE PHYSICS] in Chinese Vol 10 No 1, Mar 88 pp 1-3

[English abstract of article by Cui Changgeng [1508 7022 1649], et al., of the Institute of Physics, Chinese Academy of Sciences, Beijing; He Yeye [0149 2814 0396] of the Cryogenic Laboratory, Chinese Academy of Sciences, Beijing]

[Text] In December 1986, a Ba-La-Cu oxide was prepared and the temperature dependence of resistance was measured by the four-point method. Zero resistance temperatures were found to be 53 K and 67 K for samples A and B, respectively. The results of resistance transition under 10 kbar show  $T_c$  (onset) is 94 K for sample B. About 2 months later the mutual-inductance method was adopted to measure the ac magnetic susceptibility using a new measuring system. The onset of diamagnetism was 83 K and 79 K for samples A and B, respectively.

9717

## PREPARATION OF ULTRA-FINE Ba-Y-Cu-O SYSTEM POWDER, SUPERCONDUCTIVITY

40090075b Beijing DIWEN WULI XUEBAO [CHINESE JOURNAL OF LOW TEMPERATURE PHYSICS] in Chinese Vol 10 No 1, Mar 88 pp 4-7

[English abstract of article by Zhang Han [1728 6799], et al., of the Department of Applied Chemistry and the Department of Physics, University of Science and Technology of China, Hefei]

[Text] This paper introduces the research involving the preparation of ultra-fine Ba-Y-Cu-O system powder and its superconductivity. The ultra-fine Ba-Y-Cu-O powder is obtained by reacting the aqueous solutions of  $\text{Ba}(\text{NO}_3)_2$ ,  $\text{Cu}(\text{NO}_3)_2 \cdot 3\text{H}_2\text{O}$  and  $\text{Y}(\text{NO}_3)_3$  at  $\text{pH} > 14$ , i.e., 2.2415 g of  $\text{Ba}(\text{NO}_3)_2$  is mixed with 7.7488 g of  $\text{Cu}(\text{NO}_3)_2 \cdot 3\text{H}_2\text{O}$  and 1.8284 g of  $\text{Y}_2\text{O}_3$  (dissolved in 1:1  $\text{HNO}_3$ ). KOH solution is added to reach  $\text{pH} > 14$ . The reaction time is 24 hours at  $70^\circ\text{C}$ . The precipitate is washed several times, then filtered and dried at  $100^\circ\text{C}$ . X-ray analysis, electron diffraction and TEM show that the powder consists of very fine particles of about 100 Å. Made into a superconductor, it has  $T_c$  (onset) = 150 K,  $T_c$  (min) = 93 K and  $T_c$  ( $\rho = 0$ ) = 90.5 K, and it has a higher melting point and greater strength than that made by the ceramic method.

9717

PREPARATION OF CERAMIC SUPERCONDUCTOR FROM ULTRAFINES BY FREEZE-DRY PROCESS  
IN Ba-Y-Cu-O SYSTEM

40090075c Beijing DIWEN WULI XUEBAO [CHINESE JOURNAL OF LOW TEMPERATURE  
PHYSICS] in Chinese Vol 10 No 1, Mar 88 pp 8-11

[English abstract of article by Chen Zuyao [7115 4371 5069], et al., of the  
Department of Applied Chemistry, University of Science and Technology of  
China; Rong Jingfang [2051 2533 5364] of the Department of Modern Chemistry,  
University of Science and Technology of China; Zhao Yong [6392 0516], et al.,  
of the Department of Physics, University of Science and Technology of China]

[Text] The freeze-dry technique is reported for the first time for preparing  
ceramic ultrafines. The single-phase complex oxide  $Ba_2YCu_3O_{9-\delta}$ , a poly-  
crystallized compound, and ceramic superconductor have been synthesized  
successfully. The experimental results show that not only is the ceramic  
superconductor obtained uniform with fine particles and excellent super-  
conductivity, but also the solid reaction conditions are quite moderate.

9717

RESEARCH ON FORMATION ENERGY OF MPZ ( $E_{\min}$ ), PROPAGATION OF NORMAL ZONE IN VARIOUS WINDING TECHNIQUES

40090075d Beijing DIWEN WULI XUEBAO [CHINESE JOURNAL OF LOW TEMPERATURE PHYSICS] in Chinese Vol 10 No 1, Mar 88 pp 25-34

[English abstract of article by Jiao Zhengkuan [3542 2973 1401], et al., of the Institute of Plasma Physics, Chinese Academy of Sciences, Hefei]

[Text] The dependence of the formation energy of MPZ ( $E_{\min}$ ), propagation velocity of the normal zone ( $V_n$ ) and the minimum propagation current ( $I_p$ ) in Nb-Ti superconducting magnets on the transport current ( $I$ ) and magnetic field ( $B$ ) have been studied. The magnets are wound by the wet process (brushing wax adding  $Al_2O_3$  with high thermal conductivity or  $Gd_2O_3$ ). It is found that  $E_{\min}$  is not obviously raised with the impregnating techniques. The high stability probably occurs from diminishing the movement of the wires.

9717

OBSERVATION OF MICROSTRUCTURE IN NbTi/Cu SUPERCONDUCTORS BY SEM

40090075e Beijing DIWEN WULI XUEBAO [CHINESE JOURNAL OF LOW TEMPERATURE PHYSICS] in Chinese Vol 10 No 1, Mar 88 pp 35-39

[English abstract of article by Wu Xiaozu [0702 2556 4436], et al., of Baoji Institute for Non-ferrous Metal Research]

[Text] The typical SEM microstructure of an excellent critical current density NbTi/Cr superconductor is found to have a very fine and clear sub-band as well as a homogeneously-distributed plate-like precipitate. Its characteristics can be obtained by multiple heat treatment techniques. Obviously, the SEM observation method, with the advantages of easy sample preparation, wide view field and successive magnification, helps to ensure the quality of the NbTi/Cu superconductors in industrial production.

9717

R-H SUPERCONDUCTING PHASE TRANSITION IN  $Nb_3Sn$  ALLOYED WITH Ti

40090075f Beijing DIWEN WULI XUEBAO [CHINESE JOURNAL OF LOW TEMPERATURE PHYSICS] in Chinese Vol 10 No 1, Mar 88 pp 68-74

[English abstract of article by Mao Xianglei [3029 0686 7191], et al., of the Department of Physics, University of Science and Technology of China, Hefei]

[Text] The R-H superconducting transition in  $Nb_3Sn$  alloyed with Ti has been measured under the pulse magnetic field. An ideal superconducting-normal transition curve is obtained when a small measured current is applied. The flux flow resistance and the real  $H_{c2}$  have been determined. The authors have studied the thermal effect under large currents. It is pointed out that defining the starting point of the flux flow resistance as the S-N transition point is correct, no matter how large the measured current applied. The relationship of the disturbance voltage induced by the pulse magnetic field and the properties and size of the material is also discussed in this paper.

9717

## BRIEFS

SUPERCONDUCTOR EXCITATION DEVICE--Liu Erzhong and Cao Zhongsheng, instructors at the China University of Science and Technology graduate school, have developed a new high-temperature superconductor excitation device. Specialists believe this to be significant in that it attempts to break with traditional low-temperature superconductor device design, making it applicable to the characteristics of new high-temperature superconducting materials and expanding the horizons of superconductor applications research. The excitation coil of the device is made of a superconducting ring formed by pressurized sintering of three yttrium-barium-copper oxide materials. Then, when cooled by liquid nitrogen, the magnetic field produced by the induced continuous current drives the rotor to generate electricity. [Summary] [40090132a Beijing RENMIN RIBAO in Chinese 30 Apr 88 p 4]

SUPERCONDUCTOR RESEARCH BREAKTHROUGHS--Making use of barium-yttrium-copper oxide superconducting materials from the Beijing Institute of Nonferrous Metals, China's Institute of Metrology has developed an rf SQUID [superconducting quantum interference device]. On 29 March a flux output wave (triangular wave) was observed for the first time in the liquid nitrogen temperature range, and under the influence of an external magnetic field the wave changed noticeably. The device remained unchanged through many temperature cycles (77K-300K). This achievement has opened the door to a broad range of applications of high-temperature superconductors [Excerpt] [40090132b Beijing RENMIN RIBAO in Chinese 3 Apr 88 p 4]

SUPERCONDUCTOR MOTOR--On 28 March Xi'an Jiaotong University successfully operated China's first superconductor electric motor. The device, which makes use of the Meissner effect, operates at 500 rpm. The principal researcher is 64-year-old Fei Hongfei. [Excerpt] [40090132c Beijing RENMIN RIBAO in Chinese 3 Apr 88 p 4]

Achievements of MPT's Institute 10

40080102b Tianjin JISHU SHICHANG BAO [TECHNOLOGY MARKET NEWS] in Chinese  
3 Feb 88 p 1

[Summary] The 30-plus major technological achievements of the Ministry of Posts and Telecommunications' Institute 10 include 128/256-line microcomputer automatic repeating telegraphic equipment that meets international standards for the eighties and China's first advanced-technology program-controlled long-distance terminal exchange equipment (the model JZD72). The institute's development of a 1024-line program-controlled digital long-distance automatic telephone exchange installation--a key State project for the Seventh 5-Year Plan--was completed at the end of 1987 and is expected to be put into production this year. The current thrust of the institute is toward providing small-to-medium-size cities and numerous rural towns with local automatic telephone network installations. Economic returns are also notable: profits turned over to the State are increasing yearly. In 1987, the institute's output value of almost 20 million yuan resulted in a profit of over 2 million yuan, eight times that of 1977. Over 700,000 yuan in state taxes were paid last year.

/12223

Digital Multiplexing Equipment

40080102e Tianjin JISHU SHICHANG BAO [TECHNOLOGY MARKET NEWS] in Chinese  
6 Feb 88 p 4

[Summary] China's independently designed and developed new models of digital multiplexing equipment--for 8 Mbps, 34 Mbps, and 140 Mbps communications--recently underwent ministry-level evaluation at the Ministry of Posts and Telecommunications' Meishan [4168 1472] Communications Equipment Plant. This equipment, whose equivalent voice-channel capacity has reached 1,920 lines, is characterized by high transmission quality, strong security, low power consumption, and low weight, and requires minimal investment of funds. It can be used in high-capacity long-distance fiber-optic cable, electric-cable, and digital microwave systems.

/12223

Subminiature Linear Predictive Vocoder

40080102g Tianjin JISHU SHICHANG BAO [TECHNOLOGY MARKET NEWS] in Chinese  
13 Feb 88 p 4

[Summary] The CAS's Institute of Acoustics has developed a subminiature linear-predictive-coding vocoder that provides a degree of security which is at the domestic state-of-the-art. Its scrambled output signal is synthesized into speech by a digital signal processor at the receiving end of the transmission. This medium for secure communications is suitable for military command, navigation, aviation, and government departments in charge of confidential work, and also is of major importance for satellite communications, counterintelligence, and safeguarding state security. This low-cost, low-power-consuming third-generation vocoder is a full magnitude smaller than its second-generation predecessor. Stability and reliability are significantly improved, and the score for the clarity of the synthesized speech has improved 7-8 points. Initial testing via local telephone, long-distance telephone, and satellite shows that the aforementioned clarity matches that of similar foreign products. This vocoder uses a standard communications interface, permitting easy linkup to universal networks.

/12223

First 4-mm Diffraction Radiation Oscillator

40080102i Tianjin JISHU SHICHANG BAO [TECHNOLOGY MARKET NEWS] in Chinese  
17 Feb 88 p 1

[Text] China's first 4-mm diffraction radiation oscillator, a millimeter-wave device developed by the High-Energy Research Department of the Chengdu Institute of Telecommunication Engineering, recently underwent evaluation by the Ministry of Electronics Industry. China is only the second country in the world to develop this device, which has broad applications in plasma diagnosis for controlled fusion, high-frequency-stability microwave measurements, radiation-spectrum instruments, communications radars, and materials science.

/12223

Asynchronous Communications Modem

40080102j Beijing DIANZI SHICHANG in Chinese 18 Feb 88 p 2

[Summary] The DS-861 asynchronous communications modem, which underwent design finalization in 1987, is manufactured by the Shenyang Computer Plant and sells for 2000 yuan. It has a maximum range of 10 km and a transmission rate of 300-19,200 bauds. This unit requires no external ac or dc power source, thereby eliminating the problem of interference between the power source and the data cable, and uses an EIA-232-C telecommunications interface. Input sensitivity is less than or equal to 7vpp for transmitting and less than or equal to 100mvpp for receiving. Output amplitude for a 400-ohm load is greater than 350mvpp for 1000-Hz transmission and greater than 300mvpp for 10-Hz transmission; for a 4.7-kilohm load, output amplitude is greater than 7vpp for 0-10-KHz transmission.

/12223

TELECOMMUNICATIONS R&D

Minister Discusses Rural Radio, TV Development

40100025a Beijing Domestic Service in Mandarin 2130 GMT 7 May 88

[From the "News and Press Review" program]

[Text] From 26 April to 6 May, Ai Zhisheng, minister of radio, film, and television, visited 14 counties, some townships and towns, and some peasant households in Hunan's Changde Prefecture, Huaihua City, and Xiangxi Tujia-Miao Autonomous Prefecture, and Hubei's (?Exi) and other localities, conducting a survey of radio and television development in rural areas. He put forward three opinions on the future development of radio and television work in rural areas. He said: First, Broadcasting networks in rural areas are very important. They are indispensable propaganda tools for our party committees and governments at all levels. All of us should fully understand this. We should make broadcasting networks effective tools for conducting ideological and political work in the new situation. Second, peasants like television very much. The speed of television development has been encouraging. However, currently it is a big problem how to provide good television service to peasants. In general, television reception in flatlands is better than in hilly areas, and reception in hilly areas is better than mountain areas. Television reception problems are more serious in mountain areas where some peasants receive only the sound but not pictures. Radio and television departments at all levels should set up a technical force to help peasants in mountain areas improve their television reception. Third, development of radio and television work in rural areas has met with shortages of funds, electrical power, and material resources. Therefore, we should not blindly develop radio and television work in rural areas but give priority to some more important and urgent projects. Except in some special cases, counties should not be encouraged to set up television stations. Television stations at all levels also should not stress the number of programs they have produced but provide good reception for programs aired by the Central Television Station and the local provincial television station. County and township radio stations should relay more programs of the Central Radio Station and the local provincial radio station in order to satisfy the peasants' cultural needs.

/12223

Radio Minister Investigates Hunan Situation

40100025b Changsha Hunan Provincial Service in Mandarin 2200 GMT 6 May 88

[Text] Yesterday [6 May-FBIS], Ai Zhisheng, minister of radio, film, and television, gave a report on his investigation of our province's radio and television to provincial party committee and provincial government leaders. Leading comrades of the provincial party and government, including Xiong Qingquan, Liu Zheng, Wang Xiangtian, and Xia Duanzhong, listened to his report on his investigation.

Minister Ai Zhisheng arrived in our province on 25 April. He mainly investigated and wanted to understand the development of the rural radio and television of our province. Accompanied by (Yang Shifang), director of the provincial Radio and Television Department, and (Li Qinglin), deputy director, he traveled over 2,000 kilometers in 10 days and went deep into dozens of radio and television stations and many peasant families in more than 10 counties and cities in Changsha, Yiyang, Changde, Huaihua, and Xiangxi Autonomous Prefecture to seriously listen to the views of the leaders and the masses of these places on the radio and television work. He especially investigated in detail how the peasants of the remote and poor mountain areas of Xiangxi can listen in radio and watch television well and exchanged views with the leading comrades of the provincial party and government.

Minister Ai Zhisheng said: Rural radio and television is very important. In particular, village radio at the below the county level has become the mouth of the party and government, the legs of the grass-roots cadres, and an indispensable instrument for rural commodity production and cultural life. Solving the problems of listening to the radio and watching television of the masses of these places is a very important matter. Television stations must not blindly concentrate on the increase in programs but must strive to increase the rate of coverage, to improve the quality of the programs, and to step up technological service work on the foundation of relaying the central, provincial, and city programs. Radio stations must do so, too. They must persistently combine wired and wireless broadcasts. Counties to townships and villages must preferably use FM broadcasting while townships to villages and households must use wired broadcasting. The

whole countryside must build up radio and television in light of the realities of the initial stage of socialism and strive to spend less money and to do more work. In general, the units below the county level must not set up a television station.

When Minister Ai Zhisheng was in Yiyang, he heard that Yiyang Prefecture and City jointly ran a station. He said very gladly: This method is good. A city runs a station. It can concentrate its energy to run the station well. A city must not run several stations.

Minister Ai also exchanged views with the leaders of the provincial party committee and provincial government.

While they were dealing with the administration of video recording by the relevant departments, provincial party committee Secretary Xiong Qingquan said: Before the State Council officially sends down a document, we must still act in accordance with central authorities' Document No. 45 of 1985. It must be administered by the Radio and Television Department.

/12223

## BRIEFS

BROADBAND VARACTOR TUNING FOR RADARS--The development of a ka-band suspension microstrip varactor solid-state source by the Applied Physics Department of the Chengdu Institute of Telecommunications Engineering demonstrates that China has mastered broadband varactor tuning technology in the 8-mm-area. This solid-state source is a key component in automatic frequency tracking systems, frequency agile radars, FM continuous-wave radars, phaselock-technique systems, sweep frequency receivers, automatic testing equipment and the like. This totally domestically made product consists of a Gunn diode, a varactor diode, and a copper dielectric substrate. [Summary] [40080130a Tianjin JISHU SHICHANG BAO [TECHNOLOGY MARKET NEWS] in Chinese 24 Feb 88 p 4]

MICROCOMPUTER TARGET MONITORING SYSTEM--The Chongqing Communications Institute of the PLA and the National Economic Information Center have jointly developed a microcomputer monitoring system for moving targets. Once a target appears, the computer controls a 3-frame-per-second videorecorder pickup system and automatically stores the images. It can simultaneously monitor 4-8 moving targets, recall 2,000 images within 5 minutes, and print out a photograph in 15 seconds. [Summary] [40080130b Tianjin JISHU SHICHANG BAO [TECHNOLOGY MARKET NEWS] in Chinese 24 Feb 88 p 4]

FIBER-OPTIC TELEPHONE SYSTEM--Japan's Optical Industrial Technology Promotion Society, which has been making an effort to popularize optical technology applications systems in other countries, is planning to set up a fiber-optic telephone system in the Beijing Posts and Telecommunications Institute, an organization responsible for training executives for the telecommunications and postal networks in the PRC. The fiber-optic telephone system will connect the headquarters of the institute with other buildings on the grounds, and it will be possible to obtain an evaluation of the system while it is being used for technical instruction. Project costs for the system, which is scheduled for completion in JFY 1988, will be something over 100 million yen, although the Chinese will be able to use it free of charge. [Summary] [40080130c Tokyo OPTRONICS in Japanese No 3, Mar 88 p 63]

HIGH-EFFICIENCY COMMUNICATIONS NETWORK--A new domestically advanced high-efficiency communications network--the "Jump" wide-area microcomputer network--recently developed by the Computer Department of Xi'an Jiaotong University has undergone MEI-supported accreditation and has been successfully tried out in public telephone networks in Xi'an and between Xi'an and Beijing. This network provides packet switching of information between computers over local and long-distance lines, unites arbitrary topological structures between

various communications processors, and provides error re-transmission, and adaptive dynamic routing selection. [Summary] [40080130d Tianjin JISHU SHICHANG BAO [TECHNOLOGY MARKET NEWS] in Chinese 5 Mar 88 p 1]

HIGH-FREQUENCY TUNING MODULE--This module, 5,000-10,000 sets of which can be manufactured yearly by the Nanjing Xinlian [2450 5114] Machinery Plant at a unit price of 2,000 yuan, is a key component in satellite television receiver only (TVRO) systems, microwave repeaters, and remote control telemetry systems. It consists of a tracking filter, an image suppressing [jing pin yizhi 6975 7340 2117 0455] mixer filter, a broadband crystal amplifier, a broadband voltage controlled oscillator, and an i-f preamplifier. The module, which passed provincial-level technical certification in December 1987, is 100 percent domestically made, and is used in the model WD-5 TVRO receiver. Its test results all passed norms specified by the State Council's Leading Group for Development of Electronics Industry and by the China Satellite Corporation. With respect to image suppressing, its performance was rated superior to that of similar Japanese products of the eighties. [Summary] [40080130e Beijing DIANZI SHICHANG in Chinese 10 Mar 88 p 2]

2D-GENERATION SATELLITE TRACKING AND CONTROL SYSTEM--An "ultra-short wave unified tracking and control system," a key state military project of the Shanghai Scientific Instrument Plant of the Ministry of Astronautics Industry's China Space Technology Institute in cooperation with Institutes 32 and 39 of the Ministry of Electronics Industry, has been developed after an effort of over 2 years and successfully passed national-level factory-output acceptance check on March 26 in Shanghai. This domestically developed second-generation large-scale ground station tracking and control equipment is designed for monitoring range and velocity, remote control, and remote telemetry of vehicles within a 3,000-km range: low and medium orbit satellites, launch vehicles, and weapons systems. Differentiating it from its predecessor first-generation system is the fact that its four functions, previously dispersed, are not unified. The new system has a total of nine subsystems, including a transmitter, a receiver, and a systems data processing monitoring station. This installation, which was involved in the recent launch [7 March] of an instructional communications satellite, is highly automated and convenient to use; its performance meets international standards of the eighties. [Summary] [Shanghai WEN HUIBAO in Chinese 27 Mar 88 p 1, Beijing DIANZI SHICHANG in Chinese 7 Apr 88 p 1]

3-METER SATELLITE RECEIVING ANTENNA--The model WET-3-4 C-band 3-meter satellite television receive only (TVRO) antenna jointly developed by the Wuxi [Jiangsu Province] Radio Plant No 2 and an institute [No 14] of the Ministry of Electronics Industry passed ministry-level technical certification in December 1987; 300 sets can now be manufactured yearly. The antenna surfaces incorporate advanced technologies such as aluminum plate tension convex shaping and ram pressure shaping. Principal technical indicators are as follows: gain (G) greater than 40dB, G/t ratio greater than 20, efficiency greater than 68.6 percent, system SWR greater than 1.11, and voltage to axis ratio [dianya zhou bi 7193 1090 6519 3024] greater than 1.05. [Summary] [40080130g Beijing DIANZI SHICHANG in Chinese 7 Apr 88 p 2]

NEW SATELLITE TV PRODUCTS--The SR-J32 C-band satellite TVRO receiver, the YH3840 direct broadcast satellite (DBS) TV high-frequency head, the YH11302 satellite four-channel distributor and other new products of the China Zhenhua Electronics Industries Corporation's Yonghua Radio Instrument Plant were recently certified. The SR-J32, a model based on MEI's high-quality SR-531 receiver, is easy to operate and maintain, low in cost, and economical to use. Its development solves the problem of setting up a station in remote underdeveloped areas. [Summary] [40080130h Beijing DIANZI SHICHANG in Chinese 7 Apr 88 p 2]

FIRST 11.6-M SATELLITE EARTH STATION ANTENNA--The 11.6-meter-diameter large-scale satellite earth station receiving antenna system jointly developed by the Xi'an Microwave Equipment Plant and the Xing'an Communications Equipment Plant recently underwent ministry-level technical certification. This key project in MPT's Seventh 5-Year Plan has produced a system which meets international quality standards, according to observers at the certification. In resisting interference and adapting to climatic conditions, it is superior to similar Japanese and South Korean products, and has reached state-of-the-art. The domestic development of this system, ending China's long-standing reliance on imported large-scale satellite receiving antennas, will not only realize for the state an annual foreign-exchange savings of 1 million yuan, but also will stimulate development of domestically manufactured microwave receiving installations. [Summary] [40080130i Tianjin JISHU SHICHANG BAO [TECHNOLOGY MARKET NEWS] in Chinese 16 Apr 88 p 4]

DISTRIBUTED ETHERNET INTEGRATED COMMUNICATIONS SYSTEM-- Qinghua University's Computer Department recently developed a "Distributed Ethernet Integrated Communications System" based on its real-time transmission system for quasi-dynamic graphics, 512x512-dot 256-gray-level images, and speech over a microcomputer LAN. The network needs no centralized [file] server; each computer simply needs to be connected to an Ethernet interface board to use integrated communications software for various kinds of point-to-point real time communications. This system, which is applicable to office automation, industrial management, and distributed processing system,s passed accreditation at Qinghua Park on 5 April. [Summary] [40080130j Beijing JISUANJI SHIJIE [CHINA COMPUTERWORLD] in Chinese No 15, 20 Apr 88 p 1]

DOMESTICALLY MADE MONITOR FOR COMSAT LAUNCHES--The X-500 large-scale color monitor processing system jointly developed by the National Defense University of Science & Technology and Hunan Computer Plant was used for the first time for the launch of China's instructional communications satellite on 7 March. This monitoring system is the largest and most powerful display processing system in the country, and consists of four individual monitors united into one large monitor group. This high-resolution system can handle graphics and provides high-speed image processing. In addition to its 1,600-hue lifelike color stereo images, the system can simultaneously display 6 channels of dissimilar-content graphics and 4 channels of data and characters to monitor

the paths of deep-space (within a 35,700-km range) satellites. System quality meets international standards of the early eighties, and several technical indicators exceed those of similar foreign equipment. [Summary] [40080130k Beijing JISUANJI SHIJIE [CHINA COMPUTERWORLD] in Chinese No 15, 20 Apr 88 p 1]

ASIA'S LARGEST WANGNET COMPUTER NETWORK--The Shanghai Wang Company recently announced in Shanghai that its 20 VS-series computers used for industrial management at the Beijing Capital Iron & Steel Company will be formally joined into a WANGNET network system in June, making it Asia's largest WANGNET system. The Shanghai Wang joint venture has developed steadily since its formation: total sales last year reached US\$10 million, and the number of enterprises in China using Wang computers has reached 400. [Summary] [40080130l Beijing JISUANJI SHIJIE [CHINA COMPUTERWORLD] in Chinese No 16, 27 Apr 88 p 1]

NEW MILLIMETER-WAVE DEVICE--An 8-mm polarization separator--a key component in performance testing systems for mm-wave communications, radar, and transmission equipment--has been developed by Northwest Institute of Telecommunications Engineering, and recently underwent technical certification. Results show that this device's main technical indicators have all reached a level that satisfies the needs of current testing systems. It may be used as a diplexer for mm-wave communications equipment and as a polarization separator for mm-wave transmission performance testing systems. [Summary] [400800117a Beijing WUXIANDIAN [RADIO] in Chinese No 2, Feb 88 p 24] /9274

SATELLITE EARTH-STATION ANTENNA--The satellite earth-station antenna jointly developed by Institute 1 of MPT and the Xi'an Microwave Equipment Plant has undergone ministry-level certification. This 11.6-meter-diameter antenna has ice-dispelling equipment. Via microcomputer control, the antenna can automatically track satellites. [Summary] [400800117b Beijing DIANXIN JISHU [TELECOMMUNICATIONS TECHNOLOGY] in Chinese No 3, Mar 88 p 47] /9274

3-METER SATELLITE RECEIVING ANTENNA--The model WET-3-4 3-meter receive-only satellite antenna jointly developed by the Wuxi (Jiangsu Province) Radio Plant No 2 and Institute 14 of MEI recently underwent ministry-level certification. This antenna, which employs an improved Cassegrain system, has high precision and efficiency, with low noise and low sidelobes. Current production capacity is 500 sets per year. [Text] [400800117c Beijing DIANXIN JISHU [TELECOMMUNICATIONS TECHNOLOGY] in Chinese No 3, Mar 88 p 47] /9274

URUMQI SATELLITE EARTH STATION--Urumqi--MPT has announced that as of today, station No 2 of the Urumqi Satellite Earth Station will begin formal simultaneous transmission of the three TV programs [of China Central Television] to China's instructional communications satellite [launched 7 Mar]. This station's equipment, except for a small number of imported amplifiers, is all manufactured domestically. MPT has decided that the three programs will be simultaneously transmitted to the international satellite at 66° east longitude and to the domestic satellite at 87.5° east longitude through the end of this year. [Summary] [400800117d Beijing RENMIN RIBAO in Chinese 20 Apr 88 p 3] /9274

END