

**Reproduced From  
Best Available Copy**

TECHNICAL MEMORANDUM

3753-1/E-1 (OHE)

6 Apr 98

Distribution List

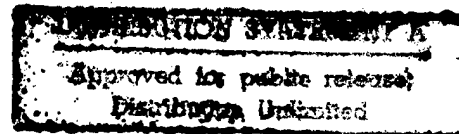

RESULTS OF CONTINUED FREEFALL HELMET IMPACT STUDIES

- Refs:
- A. Adam, J. (1998). Results Of Freefall Helmet Impact Studies. DCIEM Technical Memorandum (In Press).
  - B. Draft European Airborne Sports Helmet Standard. (1992). European Committee for Standardization: Brussels.
  - C. D-87-001-455/SF-001. (1995). Performance Specification - Helmet, Ground Troops and Parachutists for the Canadian Forces. Public Works and Government Services Canada, Revision 4. 31 Dec 1995.

SUMMARY.

A new sample foam insert for the Protec helmet was impact tested along with a standard insert to determine differences in impact protection. This testing was performed to ascertain the suitability of the new protective insert in the role of freefall parachute helmet. The testing showed that the performance of the new insert was better than the standard insert, but did not meet the standards set prior to testing.

BACKGROUND.

1. There is a continuing requirement for a protective helmet for Freefall Parachuting within the Canadian Forces. The impact protection of candidate helmets to be used in the freefall parachute role has been identified as a major concern. As such, the Defence and Civil Institute of Environmental Medicine (DCIEM) was tasked by Director Land Requirements (DLR) to perform impact testing on a new foam liner insert for the candidate helmet (Protec). This testing was to be performed as a continuation of the previous work (Ref A).

AIM.

2. The aim of this project was to measure and analyse the impact performance of a new foam insert for the Protec helmet. Comparison to the original foam insert was to be made, along with performance relative to the standards described below.

## IMPACT TESTING STANDARDS.

3. Two standards were to be used in this testing to analyze the performance of the candidate helmet. One was the European Airborne Sport Helmet Standard (Ref B - enclosed in Annex A). This standard requires the helmet to be tested with a 90 Joule (J) impact on each of the crown, front, back and both sides. The other standard was the Soldier's Helmet Parachute Impact Standard (Ref C), and required 90 J impact on the crown, and 65 J on the front, back and both sides. The pass/fail criterion for both standards was a maximum of 250 G peak headform acceleration, measured as a result of impact on any of the five impact points. The two standards were selected since there is no standard for freefall helmets, and it was felt that they would provide a reasonable standard for an analysis. The aim of the project was to test first using the Soldier's Helmet standard, and if the helmet was performing adequately the intention was then to proceed with the European Standard at a later date.

## IMPACT TESTING PROTOCOL.

4. The impact testing was performed on April 2, 1998 at the Canadian Standards Association (CSA) facility in Rexdale, Ontario. The testing protocol was exactly the same as the previous testing (Ref A). All testing was conducted by Mr. Henry Tran, a technician at CSA who specialises in impact testing.

## RESULTS.

5. As with previous testing, only the ambient temperature condition was tested. This was due to the fact that only two samples (one of each foam insert type) were available for testing. The results for the two samples are summarized in Table 1 below, and a copy of the raw data sheets are located in Annex B. The peak accelerations listed as 500+ were beyond the capability of the impact system to measure. All three impact runs for the standard insert produced peak accelerations greater than 500 G. Because there was a concern that the excessively high peak acceleration values might damage the testing equipment, the testing of the standard insert was halted after only those three individual impact runs. The special insert was tested on all five impact areas, with only the crown exceeding 500 G peak headform acceleration. The mean peak headform acceleration for the helmet with special insert was in excess of 356 G.

**Table 1: Results of impact testing at ambient condition**

Sample	Mass (kg)	Headform Used	Peak Acceleration (G)				
			Crown	Front	Left	Right	Back
Protec Standard Insert	0.411	ISO 'J'	500+	500+			500+
Protec Special Insert	0.519	ISO 'J'	500+	223	412	305	340

Grey areas indicate impact areas that were not tested

#### DISCUSSION.

6. The results indicate that the Protec helmet with the special insert does not meet either of the two standards proposed in the condition tested. The new foam does perform better than the original foam, but greater performance is still required. At this time it is not possible to endorse the use of the Protec helmet with the new liner in roles that require attenuation of impacts in the range of 65 to 90 Joules.

#### CONCLUSIONS.

7. The results of the testing show that even the Protec helmet with the new liner does not provide the required levels of protection in terms of either of the two proposed standards.

#### RECOMMENDATIONS.

8. The following recommendations are offered for the continued development of the Freefall Parachuting Helmet:

- a. The CSA testing technician (Mr. Henry Tran) suggested the use of EPP (expanded polypropylene) or EPS (expanded polystyrene) foam for the helmet liner. Using his extensive helmet testing experience, he felt that these types of foams would be more appropriate for the impact attenuation required.
- b. Further to the above, the liner is composed of three individual segments which do not fully surround the head. A moulded single-piece liner (EPP and EPS would be a solid, moulded liner as opposed to the current flexible liner) would ensure that the entire head is surrounded by foam padding, and that the maximum surface area for impact attenuation is available. This kind of complete coverage could lead to thermal comfort issues, and so should be thoroughly tested with users.

- c. Testing at both low and high temperatures is necessary to ensure that the impact attenuation of the helmet is not compromised by changes in environmental conditions.
9. DCIEM would be prepared to assist in testing further improvements to the Protec helmet, or selection of an alternate helmet that meets the required impact protection standards.

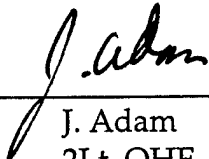
Author:  \_\_\_\_\_  
J. Adam  
2Lt, OHE

Approval: \_\_\_\_\_  
Mr. D Beevis  
H/HES

Distribution List

Action

DLR 5-3

Info

Canadian Parachute Centre

Attachments

- Annex A Draft European Airborne Sports Helmet Standard
- Annex B CSA Impact Testing Datasheets

ANNEX A  
TO 3753-1/E-1 (OHE)  
6 APR 98

EUROPEAN STANDARD  
NORME EUROPEENNE  
EUROPAISCHE NORM

DRAFT  
prEN 966

DRAFT BS DC301952/93 December 1992

UDC

Descriptors :

English version

Airborne sports helmets

Casques pour sports aériens

Luftsportheime

This draft European Standard is submitted to the CEN members for CEN enquiry.  
It has been drawn up by Technical Committee CEN/TC 158.

If this draft becomes a European Standard, CEN members are bound to comply with the CEN/CENELEC Internal Regulations which stipulate the conditions for giving this European Standard the status of a national standard without any alteration.

This draft European Standard was established by CEN in three official versions (English, French, German). A version in any other language made by translation under the responsibility of a CEN member into its own language and notified to the Central Secretariat has the same status as the official versions.

CEN members are the national standards bodies of Austria, Belgium, Denmark, Finland, France, Germany, Greece, Iceland, Ireland, Italy, Luxembourg, Netherlands, Norway, Portugal, Spain, Sweden, Switzerland and United Kingdom.

CEN

European Committee for Standardization  
Comité Européen de Normalisation  
Europäisches Komitee für Normung

Central Secretariat: rue de Stassart 36, B-1050 Brussels

© CEN 1992 Copyright reserved to all CEN members

Ref. No. prEN 966:1992 E

Contents

Foreword

- 1 Scope
- 2 References
- 3 Definitions
- 4 Materials
- 5 Construction
- 6 Performance requirements
- 7 Tests
- 8 Marking
- 9 Information for users

Annex A Positioning of the helmet on the headform

Annex B Test area

Annex C Field of vision

Foreword

This European Standard has been prepared under the direction of the Technical Committee CEN/TC 158 "Protective helmets". It specifies requirements for helmets used in airborne sports activities.

The various helmets for airborne sports are indicated in this European Standard as follows:

- Category HPG: Helmets for paragliding and hang gliding
- Category PC: Helmets for parachuting
- Category UL: Helmets for flying with ultra-light aeroplanes

The requirements cover all categories. Special requirements are contained in the relevant clauses.

The protection given by a helmet depends on the circumstances of the accident and wearing a helmet cannot always prevent death or long term disability.

A proportion of the energy of an impact is absorbed by the helmet, thereby reducing the force of the blow sustained by the head. The structure of the helmet may be damaged in absorbing this energy and any helmet that sustains a severe blow needs to be replaced even if damage is not apparent.

To achieve the performance of which it is capable, and to ensure stability on the head, a helmet should be as closely fitting as possible consistent with comfort. In use it is essential that the helmet is securely fastened, with any chin strap under tension at all times.



Page 4  
prEN 966:1992

3.4 Padding

3.4.1 Protective padding

Material used to absorb impact energy;

3.4.2 Comfort padding

Liner material provided for the wearer's comfort;

3.4.3 Sizing padding

Liner material used for adjustment of the helmet size;

3.5 Retention system

Complete assembly by means of which the helmet is maintained in position on the head, including any devices for adjustment of the system or to enhance the wearer's comfort;

3.6 Chin-strap

Part of the retention system consisting of a strap that passes under the wearer's jaw to keep the helmet in position;

3.7 Basic plane of the human head

Plane at the level of the external ear opening (external auditory meatus) and the lower edge of the eye sockets (orbits);

3.8 Basic plane of a headform

Plane relative to the headform that corresponds to the basic plane of the human head;

3.9 Reference plane

Construction plane parallel to the basic plane of the headform at a distance from it which is a function of the size of the headform;

3.10 Test area

Area of the headform in which impact tests may be conducted which corresponds to the minimum protected area of the human head.

3.11 Chin-cup

Fastening device of the chin-strap that fits round the point of the wearer's chin.

3.12 Visor

Transparent protective screen extending over the eyes and covering part of the face.

3.13 Goggles

Transparent protectors that enclose the eyes.

#### 4 Materials

For those parts of the helmet coming into contact with the skin the material used shall be known not to undergo appreciable alteration from contact with sweat or other substances likely to be found in toiletries. Materials shall not be used which are known to cause skin disorders, including cold injuries due to thermal conductivity.

#### 5 Construction

##### 5.1 General

The helmet normally consists of a shell, either containing or providing the necessary means of absorbing impact energy, and either fitted with or providing means for retaining the helmet on the head in an accident.

The helmet should have good durability and withstand normal handling.

The helmet shall be so designed and shaped that parts of it (visor, rivets, ventilators, edges, fastening device and the like) do not injure the user in normal use.

No accessories may be fitted to or incorporated in the airborne sports helmets unless it is designed in such a way that it will not cause injury and that, when it is fitted to or incorporated in the protective helmet, the helmet still complies with the requirements of this standard.

The construction of helmets category PC should take into account the risk that the lines of the parachutes might be captured by the helmet with the retention system and its accessories.

##### NOTE - Helmets should

- have low weight
- be easy to put on and take off
- be usable together with spectacles
- not significantly interfere with the ability of the user to receive acoustic ambient informations (not valid for helmets category UL)

##### 5.2 Retention system

###### 5.2.1 General

Means shall be provided for retaining the helmet on the wearer's head. All parts of the retention system shall be securely attached to the system or to the helmet.

###### 5.2.2 Chin straps

Any chin strap shall be not less than 15 mm wide.

Chin straps may be fitted with means of enhancing comfort for the wearer.

If the chin strap includes a chin cup all the tests shall be performed with the chin cup.

###### 5.2.3 Fastening devices

Any chin strap shall be fitted with a device to adjust and maintain tension in the strap. The device should be capable of adjustment so it does not come on the jaw bone.

Page 6  
prEN 966:1992

### 5.3 Finish

All edges shall be smooth and rounded. There shall be no rigid projections on the inside of the helmet. Any external projection shall not exceed 5 mm and shall be smoothly faired to the adjacent surface.

### 5.4 Field of vision

When tested in accordance with 7.4 there shall be no occlusion in the field of vision bounded by (see annex C, figures C.1, C.2 and C.3):

- horizontally: two segments of dihedral angles symmetrical in relation to the median longitudinal vertical plane of the headform and situated between the reference and the basic planes. Each of these dihedral angles is defined by the longitudinal vertical medianplane of the headform and the vertical plane forming an angle of not less than 105° with the median longitudinal vertical plane and whose edge is the straight line L K.

- upwards: a dihedral angle defined by the reference plane of the headform and a plane forming an angle of not less than 25° in the case of helmets category HPG and PC and 7° in the case of helmets category UL with the reference plane and whose edge is straight line L<sub>1</sub>, L<sub>2</sub>, the points L<sub>1</sub> and L<sub>2</sub> representing the eyes.

- downwards: a dihedral angle defined by the basic plane of the headform and a plane forming an angle of not less than 45° with the basic plane and whose edge is the straight line K<sub>1</sub> K<sub>2</sub>.

### 5.5 Head mobility

At the rear, the rigid parts and, in particular, the shell shall not be within a cylinder defined as follows (see annex B, figure B.1)

- Diameter 100 mm

- Axis, situated at the intersection of the median plane of symmetry of the headform and of a plane parallel to and 110 mm below the reference plane

### 5.6 Eye protection

It shall be possible that

- helmets category HPG and PC can be used together with goggles

- helmets category UL can be used together with goggles, except if the helmet would be equipped with a visor according to EN ... "Personal eye-protectors, visors for helmets for vehicle users"

## 6 Performance requirements

### 6.1 General

After the performance of one of the prescribed tests, the airborne sports helmet shall not exhibit any breakage or deformation dangerous to the wearer.

### 6.2 Impact absorbing capacity within the test area

The helmet shall give protection to the user's forehead, back of the head, temples and crown of the head.

#### 6.2.1 Shock absorbing capacity

When tested according to clause 7.2.3 the peak acceleration shall not, for each impact, exceed 250 g for the equivalent velocity to a drop height of 1500 mm after conditioning in accordance with any of the procedures described in 7.2.2.

#### 6.2.2 Resistance to penetration

When tested according to clause 7.2.4, the head of the punch shall not come closer than 5 mm, measured vertically, to the headform, after conditioning in accordance with any of the procedures described in clause 7.2.2.

6.3 Retention system performance

6.3.1 Retention system strength

When tested by the method described in 7.3.1, the dynamic extension shall not exceed 35 mm and the residual extension shall not exceed 25 mm. For this purpose, extension includes slippage of the fastening device. Following the test the retention system shall still permit the helmet to be released from the headform by normal operation of the release system.

Damage to the retention system shall be accepted provided that the above requirements are met.

NOTE: In this test, slippage of the fastening device may be measured and recorded separately from other contributions to the extension, but this is for information only and is not subject to separate requirement.

6.3.2 Retention system effectiveness

When tested by the procedure described in 7.3.2 the helmet, selected to be of appropriate size, shall not come off the headform.

After the test the angle between the reference line situated on the crown of the helmet and the reference plane of the headform shall not exceed 30°.

6.3.3 Release of the retention system

The retention system shall open with one hand when it is loaded with a load of 50 kg. The force for opening shall not exceed 30 N.

NOTE: It is recommended that the opening mechanism be marked with red or orange colour.

7 Tests

7.1 Sequence and number of samples to be tested

Total number submitted per helmet type: 11

Number of samples required per performance requirement are given in table 1.

Table 1: Sequence and number of samples

Performance test	Sequence of test	Number of samples tested
Retention system effectiveness	1st	2
Impact absorbing capacity	2nd	10
Resistance to penetration	3rd	1
Retention system strength	4th	4

## 7.2 Determination of impact absorbing capacity

### 7.2.1 Test area

The test area is defined by the area above the line AA-C-F (see annex B, figure B.1), when the helmet is positioned as described in annex A. The test area is subdivided into five zones: front, two sides, crown and rear.

The crown zone shall be that part of the headform and helmet above a horizontal plane through a point on the central vertical axis 10 mm below the top of the headform. The other 4 zones cover the rest of the test area as follows:

The front zone is defined as that subtended by an angle of 60° placed symmetrically about the plane of symmetry of the headform and measured from the central vertical axis.

The rear zone is defined as that subtended by an angle of 90° placed symmetrically about the plane of symmetry of the headform and measured from the central vertical axis.

Two side zones shall consist of the remaining two sections down to within 20 mm of the AA-C-F plane.

### 7.2.2 Conditioning

#### 7.2.2.1 High temperature conditioning

The helmet shall be exposed to a temperature of  $+ 50 \pm 2$  °C for not less than 4 hours and not more than 6 hours.

#### 7.2.2.2 Low-temperature conditioning

The helmets shall be exposed to a temperature of  $- 20 \pm 2$  °C for not less than 4 hours and not more than 6 hours.

#### 7.2.2.3 Ultraviolet-radiation conditioning and moisture conditioning

The outer surface of the airborne sports helmet shall be exposed alternately to:

- ultraviolet irradiation by a 125 W xenon-filled quartz lamp for 48 h at a range of 250 mm
- spraying for 4 to 6 h with water at ambient temperature at the rate of 1 l per minute

### 7.2.3 Shock absorption test

#### 7.2.3.1 Apparatus

##### 7.2.3.1.1 Description

The test apparatus shall comprise:

- An anvil rigidly fixed to a base
- A free fall guidance system
- A mobile system supporting the helmeted headform
- A metal headform fitted with a tridirectional accelerometer and a measuring assembly
- A system by which the point of impact can be brought into correspondence with the centre of the anvil.

A suitable apparatus is shown in figure 1.

7.2.3.1.2 Base

The base shall be monolithic and made of steel or concrete or a combination of these materials and have a mass of at least 500 kg.

No part of the base or anvil shall have a resonance frequency liable to affect the measurements.

7.2.3.1.3 Anvils

A flat steel anvil having a circular impact face of 130 mm ± 3 mm diameter.

A kerbstone anvil (anvil simulating a kerbstone), steel anvil having two faces making an angle of 105°, each inclined at approximately 52,5° to the vertical and meeting along a striking edge with a radius of 15 mm ± 0,5 mm. The height shall be not less than 80 mm and the length not less than 125 mm.

7.2.3.1.4 Mobile system and guides

The mobile system supporting the headform shall be such that its characteristics do not affect the measurement of acceleration at the centre of gravity of the headform. It shall also be such that any point in the area AA-C-F can be positioned vertically above the centre of the anvil.

The guides shall be such that the impact velocity is not less than 95 % of the theoretical velocity.

7.2.3.1.5 Accelerometer and measuring assembly

The tridirectional accelerometer shall be capable of measuring and recording accelerations up to 2000 g. Its maximum mass shall be 50 g.

The measuring system, including the drop assembly, shall have a frequency response in accordance with channel frequency class (CFC) 1000 of ISO 6487.

The measuring system shall include equipment to record the velocity of the headforms.

7.2.3.1.6 Headforms

The headforms to be used shall comply with EN ... and be made of a metal having a low resonance frequency below 3000 Hz.

The general characteristics of the test headforms to be used shall be as follows:

Code letter	Inside circumference of helmet mm	Mass kg
A	500	3,1 ± 0,10
E	540	4,1 ± 0,12
J	570	4,7 ± 0,14
H	600	5,6 ± 0,16
O	620	6,1 ± 0,18

The headform shall contain, near its centre of gravity, a housing for a tridirectional accelerometer.

*Handwritten notes:*  
 $v^2 = 2gh$   
 $v = \sqrt{2 \times 9,81 \times 0,25}$   
 $= 5,22 \text{ m/s}$

7.2.3.2 Procedure

The testing shall be carried out according to table 2.

Table 2 - Testing parameters

Sample number	Helmet size	Conditioning	Anvil
1	Smallest of the size range of the helmet type	High temp	Kerbstone
		No reconditioning	Flat
2		High temp	Flat
		No reconditioning	Kerbstone
3		Low temp	Kerbstone
		No reconditioning	Flat
4		Low temp	Flat
		No reconditioning	Kerbstone
5		UV + moisture	Kerbstone
		UV + moisture	Flat
6	Largest of the size range of the helmet type	High temp	Kerbstone
		No reconditioning	Flat
7		High temp	Flat
		No reconditioning	Kerbstone
8		Low temp	Kerbstone
		No reconditioning	Flat
9		Low temp	Flat
		No reconditioning	Kerbstone
10		UV + moisture	Kerbstone
		UV + moisture	Flat

The helmet shall be impacted in zones that shall be selected by the testing authority to represent the "worst case" conditions and the kerbstone anvil shall be used without any restrictions on its orientation.

Each helmet of each size shall be impacted in two different zones and each zone shall be impacted once with each anvil.

The impact sites on the same sample shall be separated by a distance of minimum 150 mm.

The velocity of the headform shall be equivalent to a drop height of 1800 mm ± 10 mm.

The velocity of the headform shall be measured at a distance not exceeding 60 mm prior to impact, to an accuracy of ± 1 %.

7.2.4 Penetration resistance test

7.2.4.1 Apparatus

7.2.4.1.1 Description

The test apparatus shall comprise:

- A test headform rigidly fixed to a base
- A metal punch and drop hammer
- A inertia-free measuring device

#### 7.2.4.1.2 Base

The base shall be monolithic and made of steel or concrete or a combination of these materials and have a mass of at least 500 kg.

No part of the base or anvil shall have a resonance frequency liable to affect the measurements.

#### 7.2.4.1.3 Rigid headform

The headforms to be used shall be according to annex D and shall be rigidly mounted in a vertical position on the base.

#### 7.2.4.1.4 Metal punch and drop hammer

The testing device shall have the following characteristics:

- Mass of punch : 0,3 kg  $\pm$  10 g
- Angle of cone forming punch head : 60°  $\pm$  1°
- Radius of rounded top of punch head : 0,5 mm
- Mass of drop hammer : 3 kg  $\pm$  25 g
- Height of fall measured between top face of punch and lower face of drop hammer : 1 m  $\pm$  5 mm

#### 7.2.4.1.5 Inertia-free measuring device

During the test the depth to which the point penetrates into shell shall be measured by means of an inertia-free device, such as a photoelectric device, indicating the minimum vertical distance researched, in this test between the head of the punch and the headform.

#### 7.2.4.2 Procedure

The airborne sports helmet shall be subjected to the penetration test at two points within the area of protection at least 75 mm distant from each other and from any earlier point of impact. The helmet shall first undergo the process of conditioning which in the opinion of the test laboratory, gave the least satisfactory results in the impact absorption test.

The helmet shall be placed, with an initial load of 10 N, on a headform oriented in such a way that the plane tangential to the shell at the point selected for the test is substantially horizontal. A metal punch with a conical head rounded at the top shall be placed vertically to touch the shell at the point selected and held in position by a ring. A metal drop hammer shall fall on the top of the punch, and the depth to which the point penetrated into the shell shall be measured.

### 7.3 Retention system testing

#### 7.3.1 Determination of retention system strength

##### 7.3.1.1 Apparatus

##### 7.3.1.1.1 Description

The test apparatus shall comprise:

- Means to hold the helmet with headform and loads
- A headform equipped with a loadbearing device comprising a guide and arrest device and a drop weight
- A measuring device

A suitable apparatus is shown in figure 2.

Page 12  
prEN 966:1992

7.3.1.1.2 Helmet support

A steel plate fitted with a bolt and shaped after the headform. See figure 3.

7.3.1.1.3 Headforms and loadbearing device

The headforms to be used shall comply with EN ....

The loadbearing device with the guide and arrest device shall be aligned with the vertical axis passing through the centre of gravity of the headform.

The mass of the headform equipped with the loadbearing device shall be  $15 \text{ kg} \pm 0,5 \text{ kg}$ , which shall be the preloading on the retention system for determining the position from which the vertical displacement of the point of application of the force shall be measured. The guide and arrest device shall allow a weight with a mass of  $10 \text{ kg} \pm 0,1 \text{ kg}$  to drop in a guided free fall  $300 \text{ mm} \pm 5 \text{ mm}$ .

7.3.1.1.4 Measuring device

A device to measure the vertical displacement of the point of application of the force.

7.3.1.2 Procedure

For each type of helmet take two helmets of each size that have just undergone the shock absorption test, one of which must have been UV-conditioned, the other sample determined by the testing authority.

Position the helmet as prescribed in annex A.

In this position the helmet shall be held by the shell by means of the helmet support at a point traversed by the vertical axis passing through the centre of gravity of the headform.

Release the drop weight and allow it to drop from a height of  $300 \text{ mm} \pm 5 \text{ mm}$ .

During the test measure the dynamic displacement of the point of application of the force.

After two minutes measure the residual displacement of the point of application of the force.

7.3.2 Determination of retention system effectiveness

The helmet shall be fitted to the appropriate headform which should be the smallest claimed for that helmet type.

A device (the total mass being  $3,0 \text{ kg} \pm 0,1 \text{ kg}$ ) to release a falling weight is hooked onto the rear part of the shell in the median vertical plane of the helmet, as shown in figure 4.

The falling weight, the mass of which shall be  $10 \text{ kg} \pm 0,01 \text{ kg}$ , is then released and drops in a guided free fall from a height of  $250 \pm 10 \text{ mm}$ . The guiding devices shall be such as to ensure that the impact speed is not less than 85 % of the theoretical speed.

7.4 Determination of field of vision

To carry out the test, the testing authority shall select the size it considers likely to yield the least favourable result for the helmet type.

Position the helmet on a headform corresponding to its size by the procedure prescribed in annex A.

Check the field of vision according to annex C.



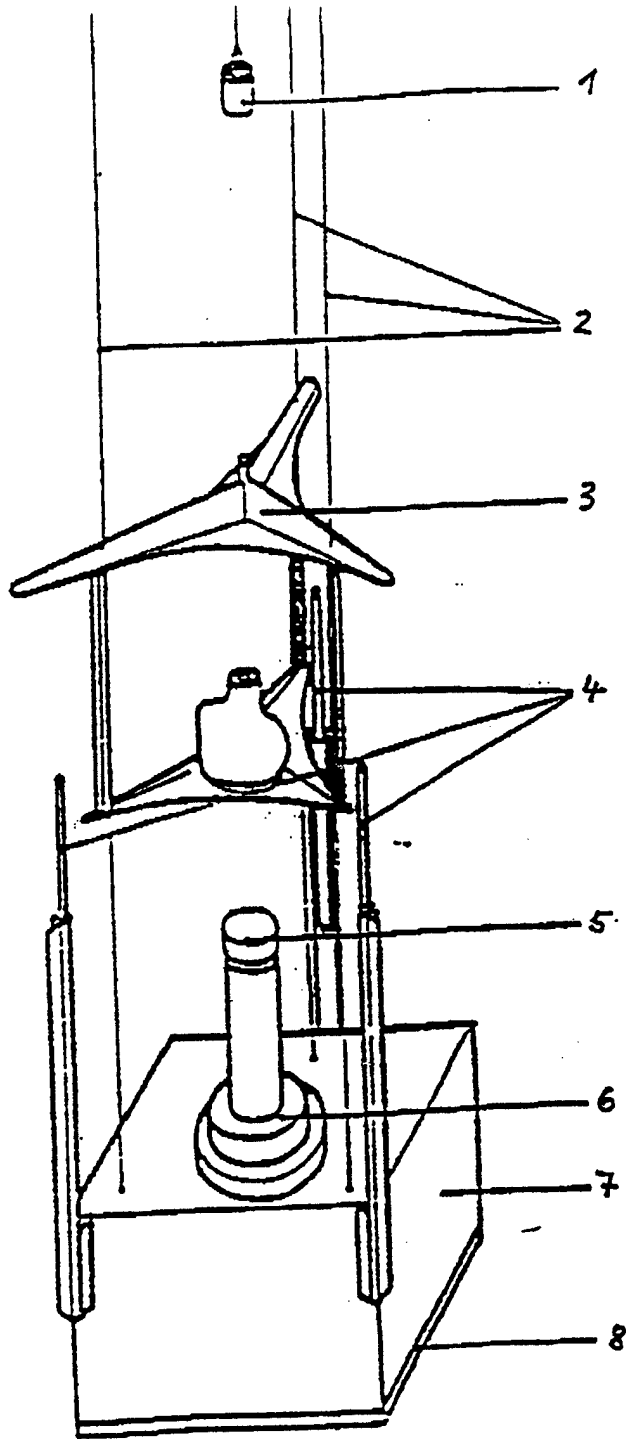

- |                           |                                |
|---------------------------|--------------------------------|
| 1 Electromagnetic dropper | 5 Anvil                        |
| 2 Guide cables            | 6 Plate magnet                 |
| 3 Headform support dolly  | 7 Steel base (at least 500 kg) |
| 4 Dolly dampers           | 8 Rubber slab (50 Shore)       |

Figure 1: Principle for testing shock absorbing capacity

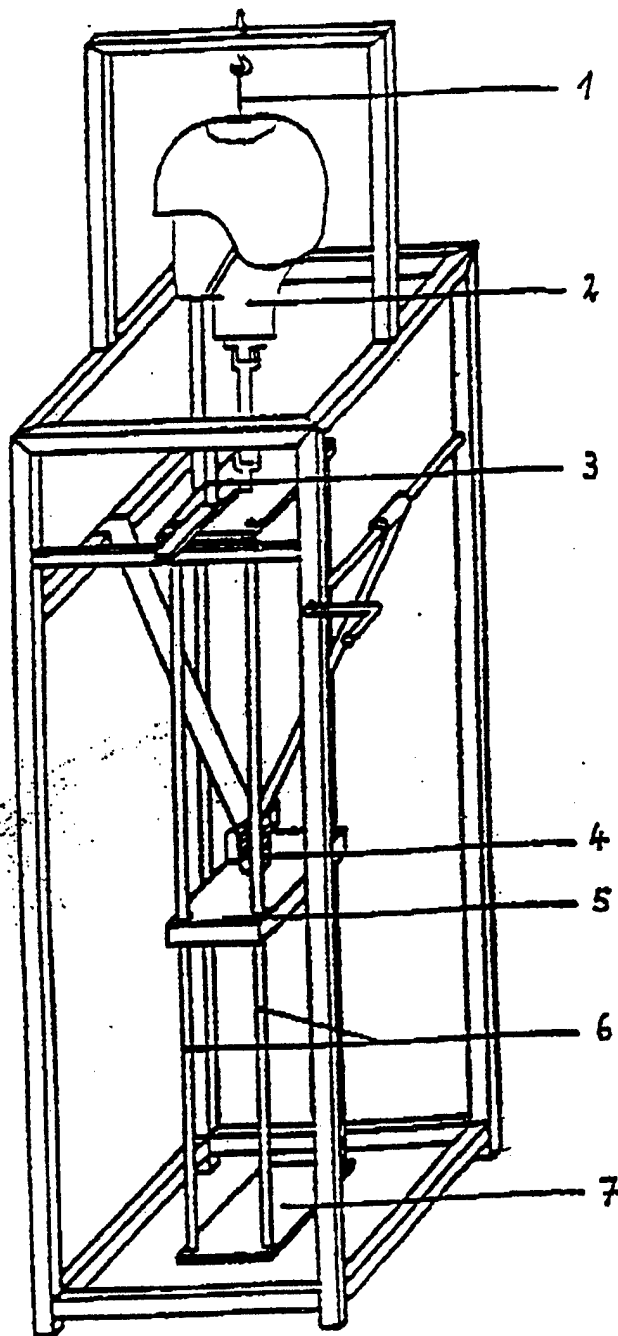

- |                         |                            |
|-------------------------|----------------------------|
| 1 Fixed helmet support  | 5 Drop weight (mass 10 kg) |
| 2 Headform              | 6 Guides                   |
| 3 Displacement recorder | 7 Anvil                    |
| 4 Drop release          |                            |

Figure 2: Apparatus for testing of retention system strength

Dimensions in millimetre.

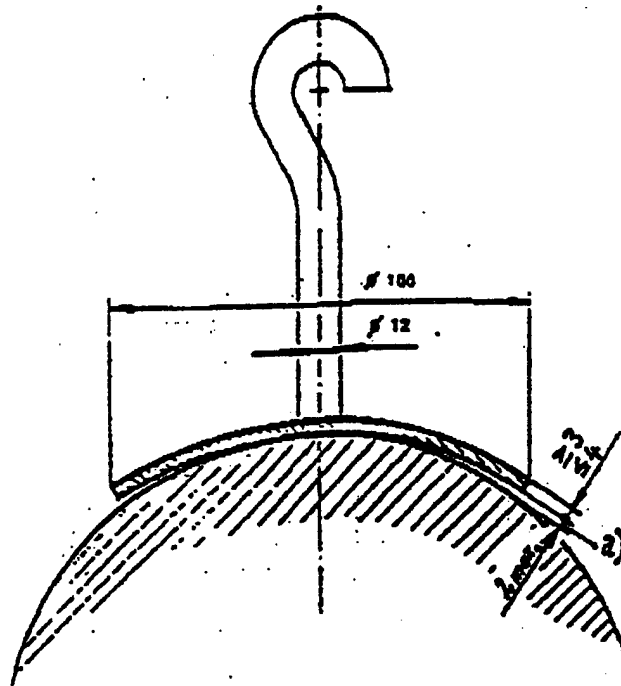

a) Deviation from headform profile.

Figure 3: Helset support

Dimensions in millimetres

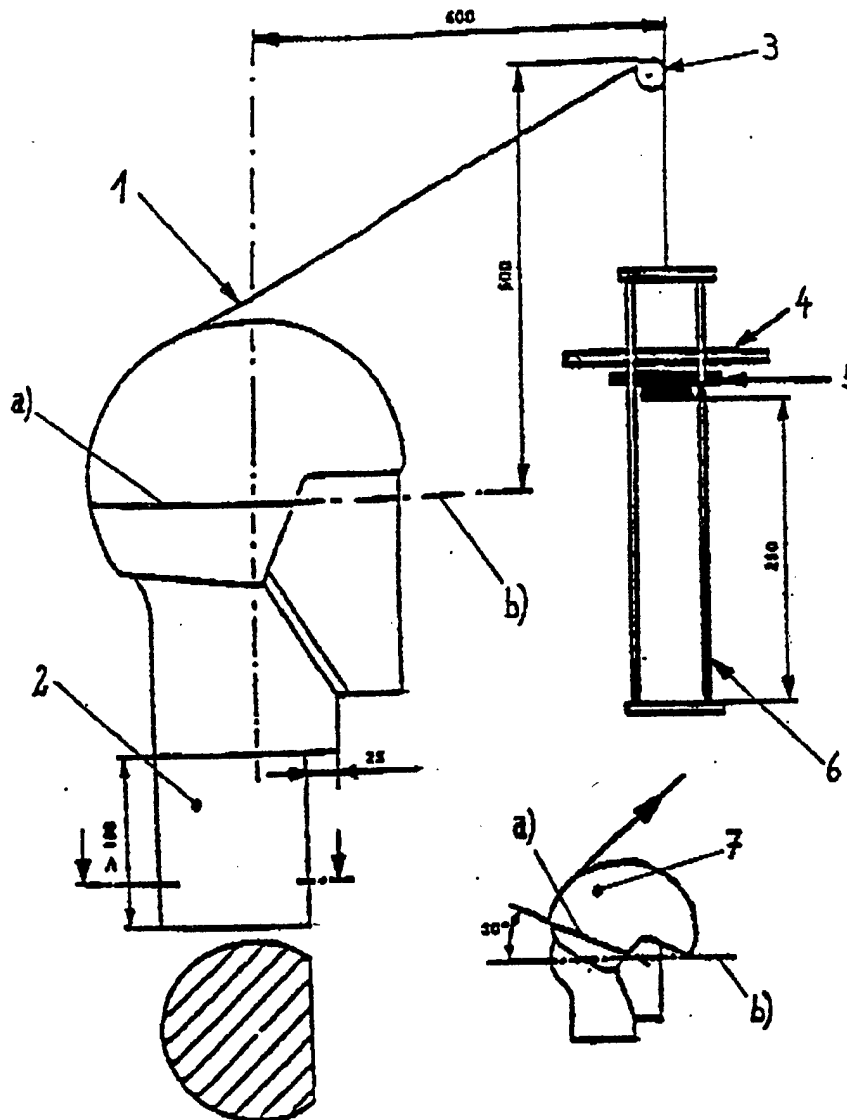

- |   |                             |
|---|-----------------------------|
| 1 Twisted steel wire, $\varnothing$ 3 min | 6 Guiding system, mass 3 kg |
| 2 Base                                    | 7 After testing             |
| 3 Pulley, $\varnothing$ 100               | a) Reference line on helmet |
| 4 Frame                                   | b) Reference plane          |
| 5 Drop weight, mass 10 kg                 |                             |

Figure 4: Principle for testing retention system effectiveness

Positioning of the helmet on the headform

1 The helmet is placed on a headform of appropriate size. A load of 50 N is applied on the crown of the helmet in order to adjust the helmet on the headform. It is ascertained that the vertical median plane of the helmet coincides with the vertical median plane of the headform.

2 The front edge of the helmet is placed against a 25° angle gauge to check the minimum angle for the upward field of vision.

Then check that the requirements for the minimum downward angle and the horizontal field of vision are satisfied.

3 The front edge of the helmet is placed against a 7° angle gauge. In that position the following lines are drawn on the helmet shell:

- a horizontal line at the level of the reference plane of the headform
- the test area limits as defined by the line AA-C-F
- the five zones (front, two sides, crown and rear) as described in 7.2.1.

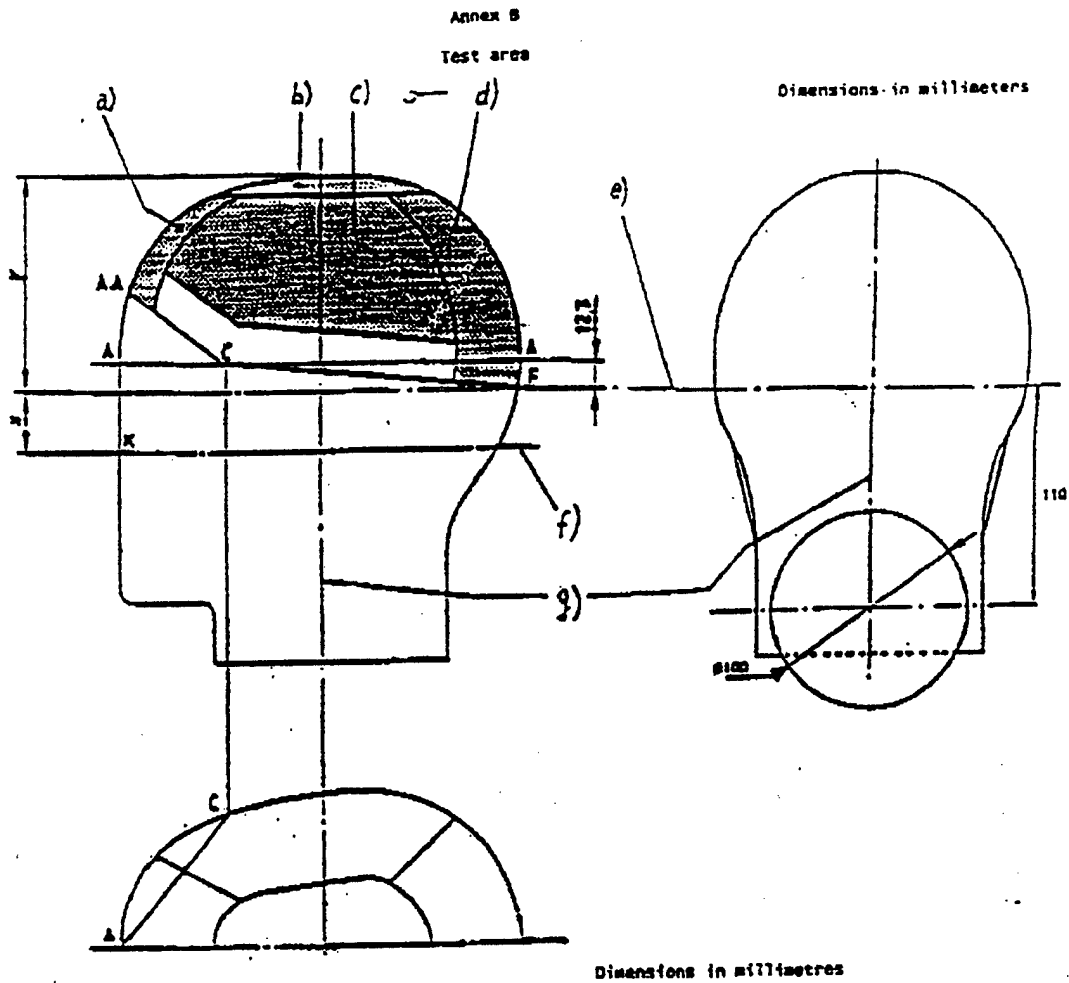

Headform Code letter	Size Inside circumference of helmet	x	y	AC
A	500	24	89,5	80
C	520	25	93	82
E	540	26	96	84
G	560	27	99	86
J	570	27,5	102,5	87
K	580	28	104	88
M	600	29	107	90
O	620	30	110	92

- a) Front zone
- b) Crown zone
- c) Side zone
- d) Rear zone
- e) Reference plane
- f) Basic plane
- g) Central vertical axis

Figure B.1: Definition of test area

Annex C  
 Field of vision

All linear dimensions  
 in millimeters

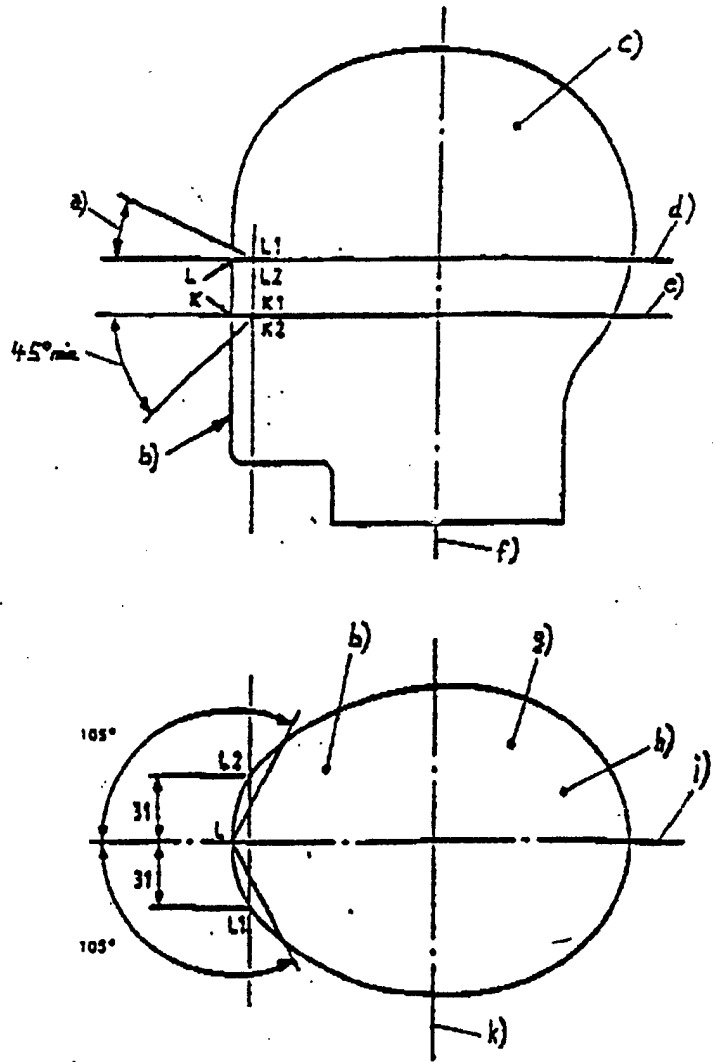

- a) Angle: 25° min in the case of categories HPG and PC and 7° min in the case of category UL
- b) Front
- c) Section of headform in longitudinal vertical plane
- d) Reference plane
- e) Basic plane
- f) Central vertical axis
- g) Section of headform in reference plane
- h) Back
- i) Longitudinal vertical median plane
- k) Central transverse vertical plane

Figure C.1: Peripheral vision



ANNEX B  
TO 3753-1/E-1 (OHE)  
6 APR 98

ACCELERATION vs TIME

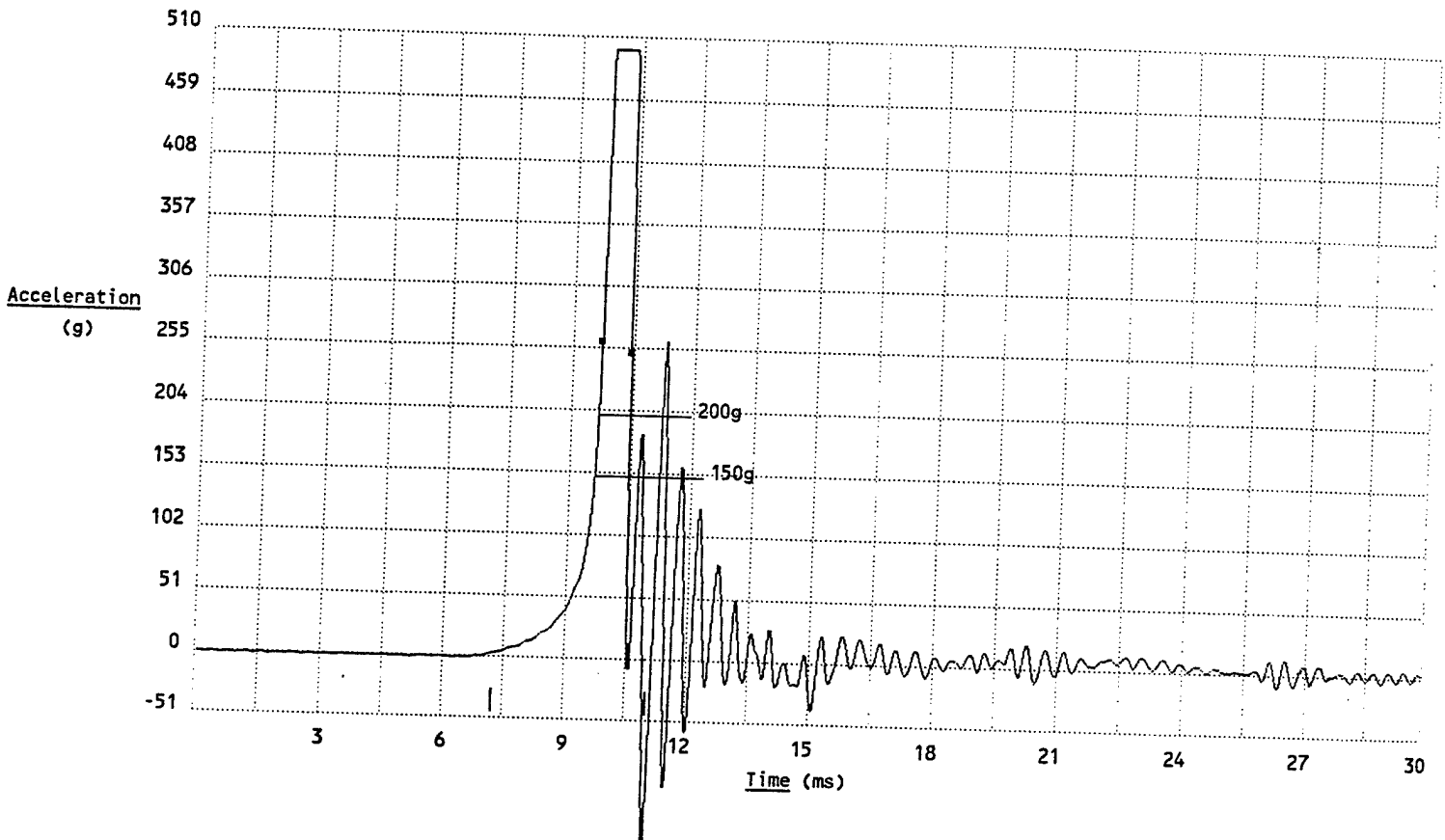

Sample #: #5 (NORMAL INSERT)

Model: PROTEC

Impact Site: CROWN

Impact Energy: 90 J

Drop Height: 1.69 M

Anvil: STEEL FLAT

Headform: ISO 'J'

Conditioning Temp.: 23C

Impact Velocity: 5.40 m/s

Peak Acceleration: 500.7 g

Area: 0.761 gs

Time to peak: 2.68 ms

Pulse width: 3.80 ms

H.I.C.: 3530.8 (between 9.7 ms and 10.4 ms)

Time above 150g: 0.9 ms

Time above 200g: 0.8 ms

DATE: 04-02-1998

ANNEX B  
TO 3753-1/E-1 (OHE)  
6 APR 98

ACCELERATION vs TIME

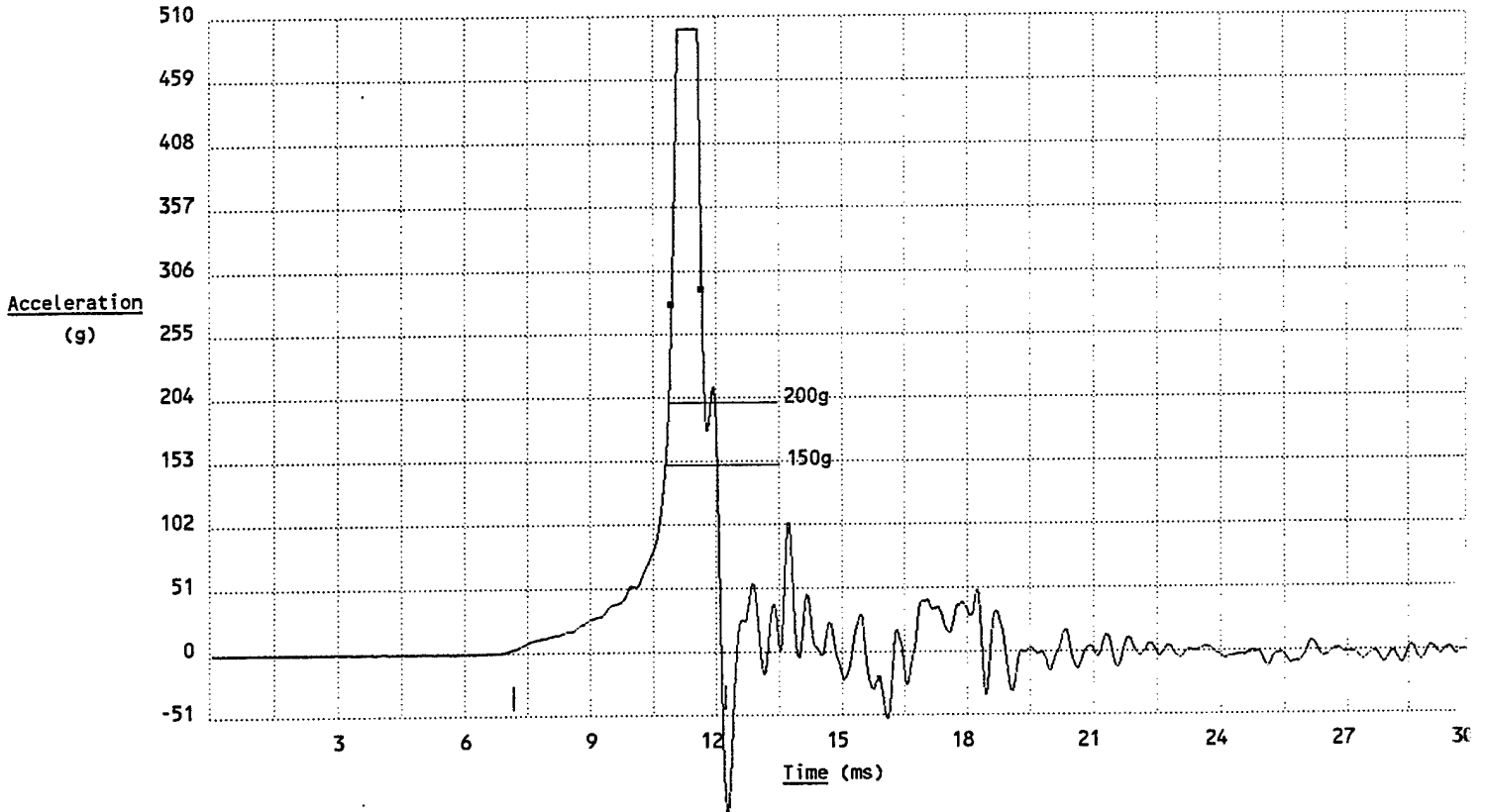

Sample #: #5 (NORMAL INSERT)

Model: PROTEC

Impact Site: FRONT

Impact Energy: 65 J

Drop Height: 1.22 M

Anvil: STEEL FLAT

Headform: ISO 'J'

Conditioning Temp.: 23C

Impact Velocity: 4.87 m/s

Peak Acceleration: 500.6 g

Area: 0.813 gs

Time to peak: 4.02 ms

Pulse width: 5.06 ms

H.I.C.: 3332.1 (between 10.9 ms and 11.6 ms)

Time above 150g: 1.3 ms

Time above 200g: 1.0 ms

DATE: 04-02-1998

ACCELERATION vs TIME

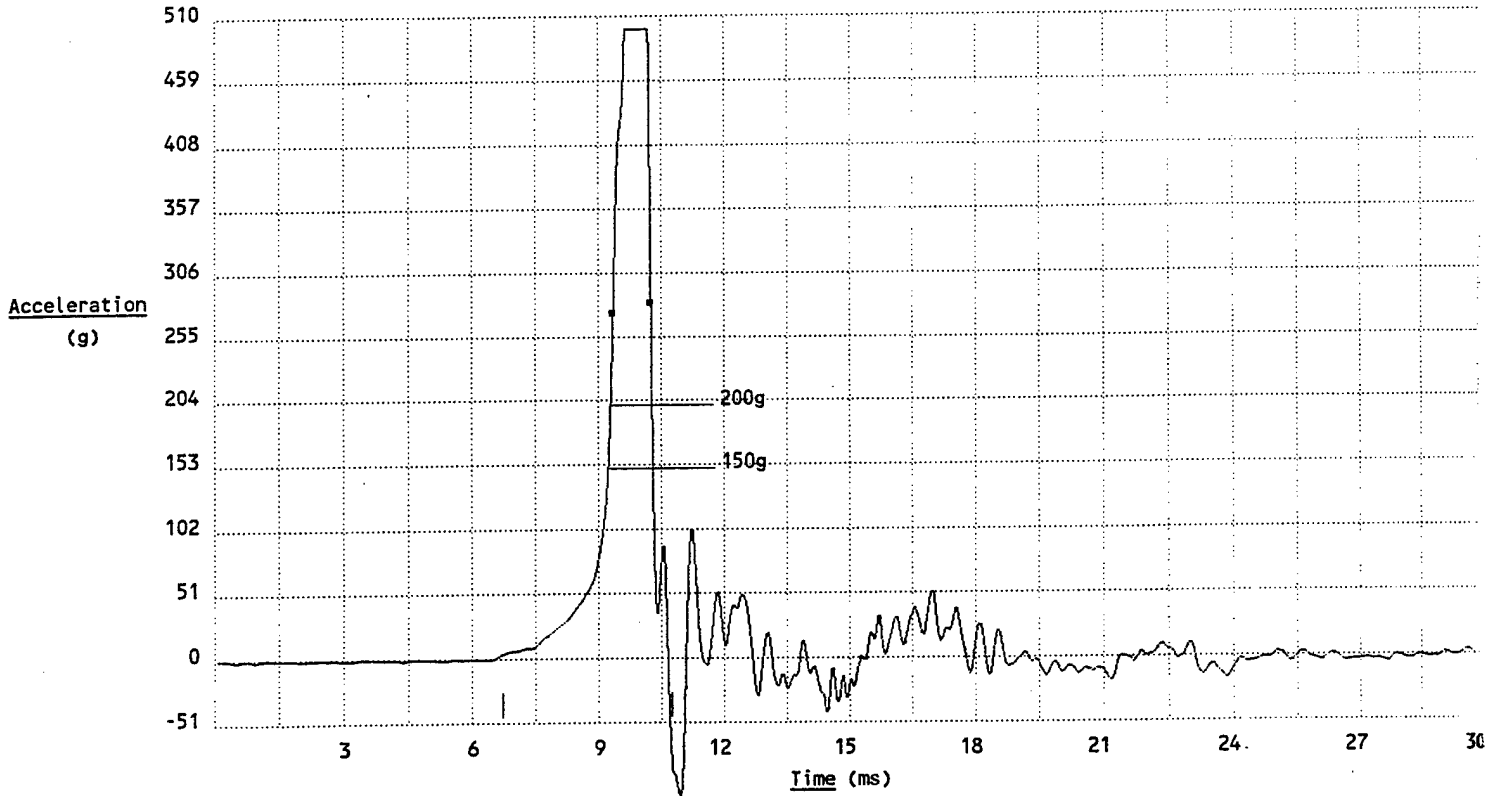

Sample #: #5 (NORMAL INSERT)

Model: PROTEC

Impact Site: REAR

Impact Energy: 65 J

Drop Height: 1.22 M

Anvil: STEELFLAT

Headform: ISO 'J'

Conditioning Temp.: 223C

Impact Velocity: 4.89 m/s

Peak Acceleration: 500.6 g

Area: 0.810 gs

Time to peak: 3.01 ms

Pulse width: 4.03 ms

H.I.C.: 4155.1 (between 9.3 ms and 10.2 ms)

Time above 150g: 1.1 ms

Time above 200g: 1.0 ms

DATE: 04-02-1998



ACCELERATION vs TIME

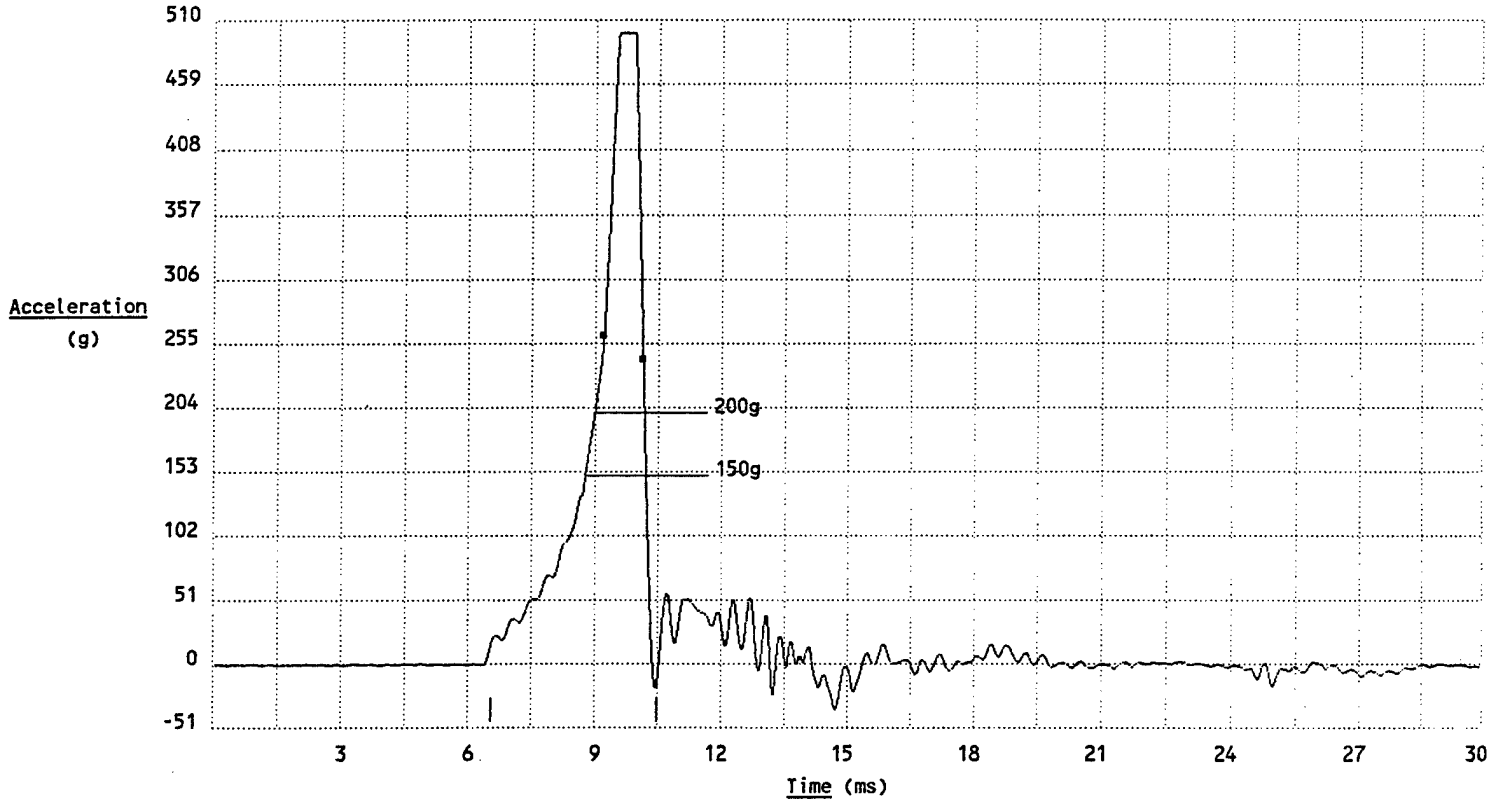

Sample #: #2 (SPECIAL INSERT)

Model: PROTEC

Impact Site: CROWN

Impact Energy: 90 J

Drop Height: 1.66 M

Anvil: STEELFLAT

Headform: ISO 'J'

Conditioning Temp.: 23C

Impact Velocity: 5.63 m/s

Peak Acceleration: 500.5 g

Area: 0.825 gs

Time to peak: 3.09 ms

Pulse width: 3.93 ms

H.I.C.: 3558.2 (between 9.2 ms and 10.1 ms)

Time above 150g: 1.4 ms

Time above 200g: 1.2 ms

DATE: 04-02-1998

ACCELERATION VS TIME

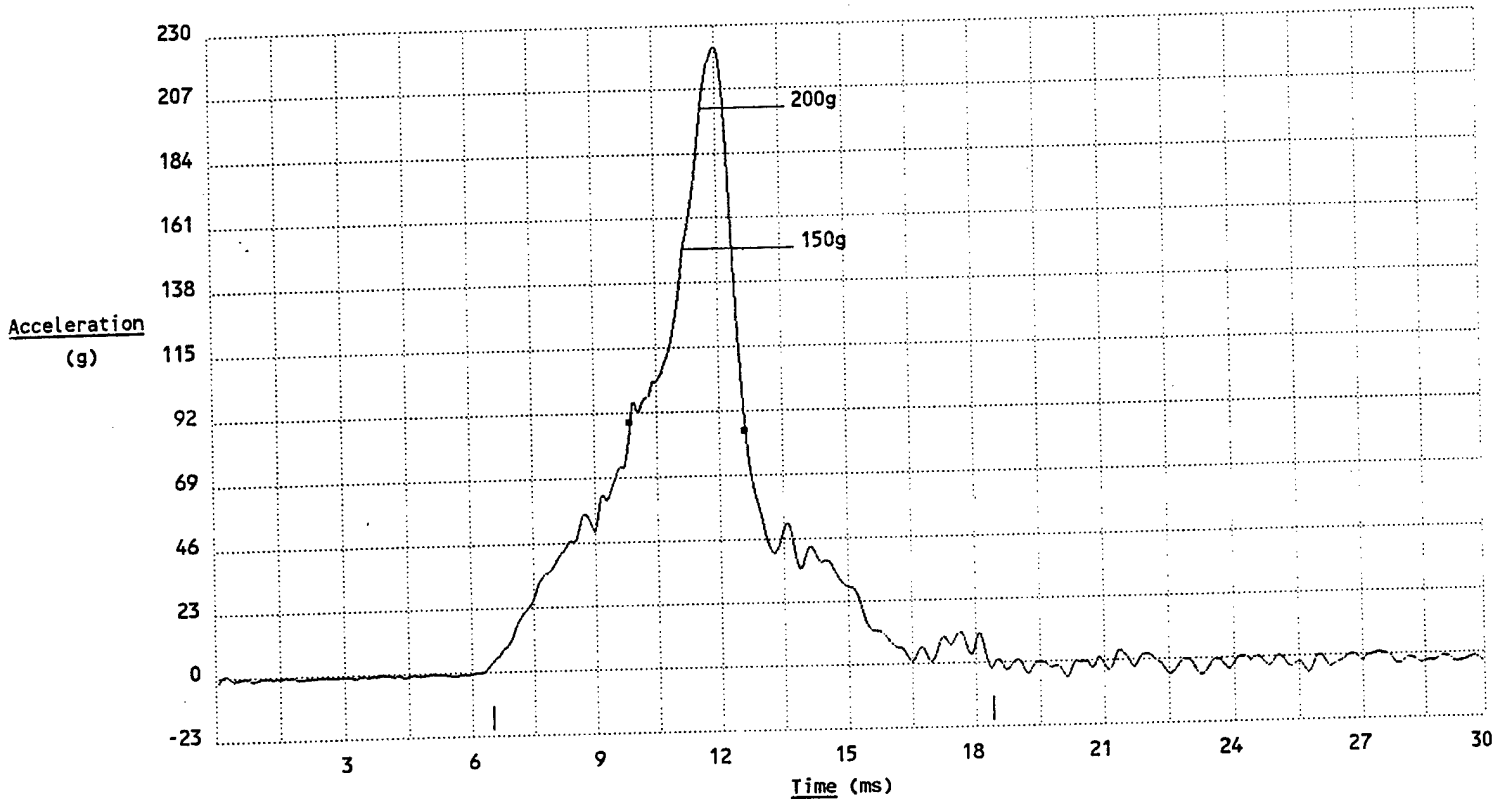

Sample #: #2 (SPECIAL INSERT)

Model: PROTEC

Impact Site: FRONT

Impact Energy: 65 J

Drop Height: 1.2 M

Anvil: STEEL FLAT

Headform: ISO 'J'

Conditioning Temp.: 23C

Impact Velocity: 4.88 m/s

Peak Acceleration: 222.7 g

Area: 0.699 gs

Time to peak: 5.57 ms

Pulse width: 11.90 ms

H.I.C.: 702.7 (between 9.8 ms and 12.6 ms)

Time above 150g: 1.2 ms

Time above 200g: 0.5 ms

DATE: 04-02-1998

ANNEX B  
TO 3753-1/E-1 (OHE)  
6 APR 98

ACCELERATION vs TIME

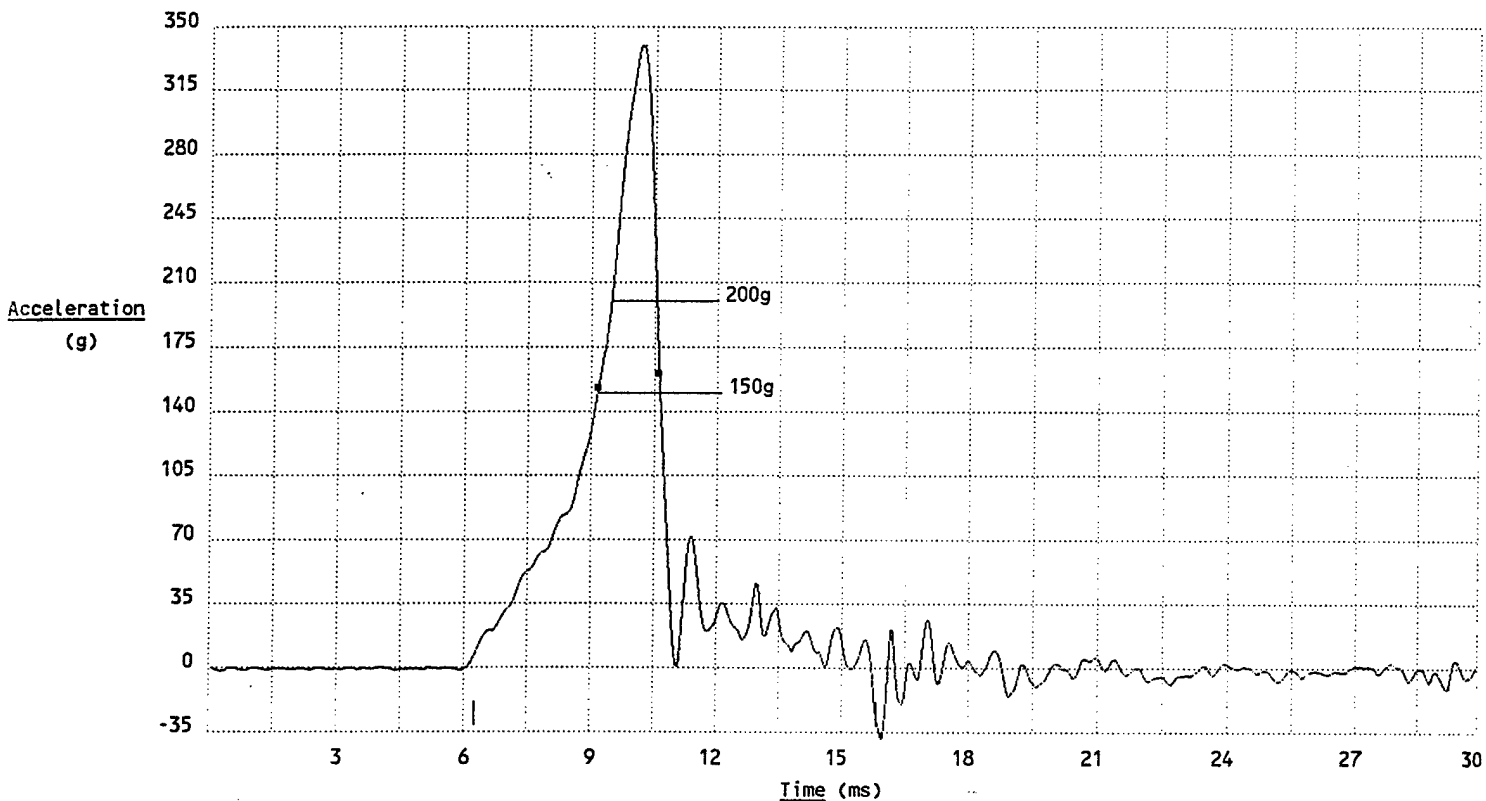

Sample #: #2 (SPECIAL INSERT)

Model: PROTEC

Impact Site: REAR

Impact Energy: 65 J

Drop Height: 1.2 M

Anvil: STEEL FLAT

Headform: ISO 'J'

Conditioning Temp.: 23C

Impact Velocity: 4.86 m/s

Peak Acceleration: 340.2 g

Area: 0.755 gs

Time to peak: 4.02 ms

Pulse width: 9.57 ms

H.I.C.: 1546.2 (between 9.1 ms and 10.6 ms)

Time above 150g: 1.5 ms

Time above 200g: 1.0 ms

DATE: 04-02-1998

ACCELERATION vs TIME

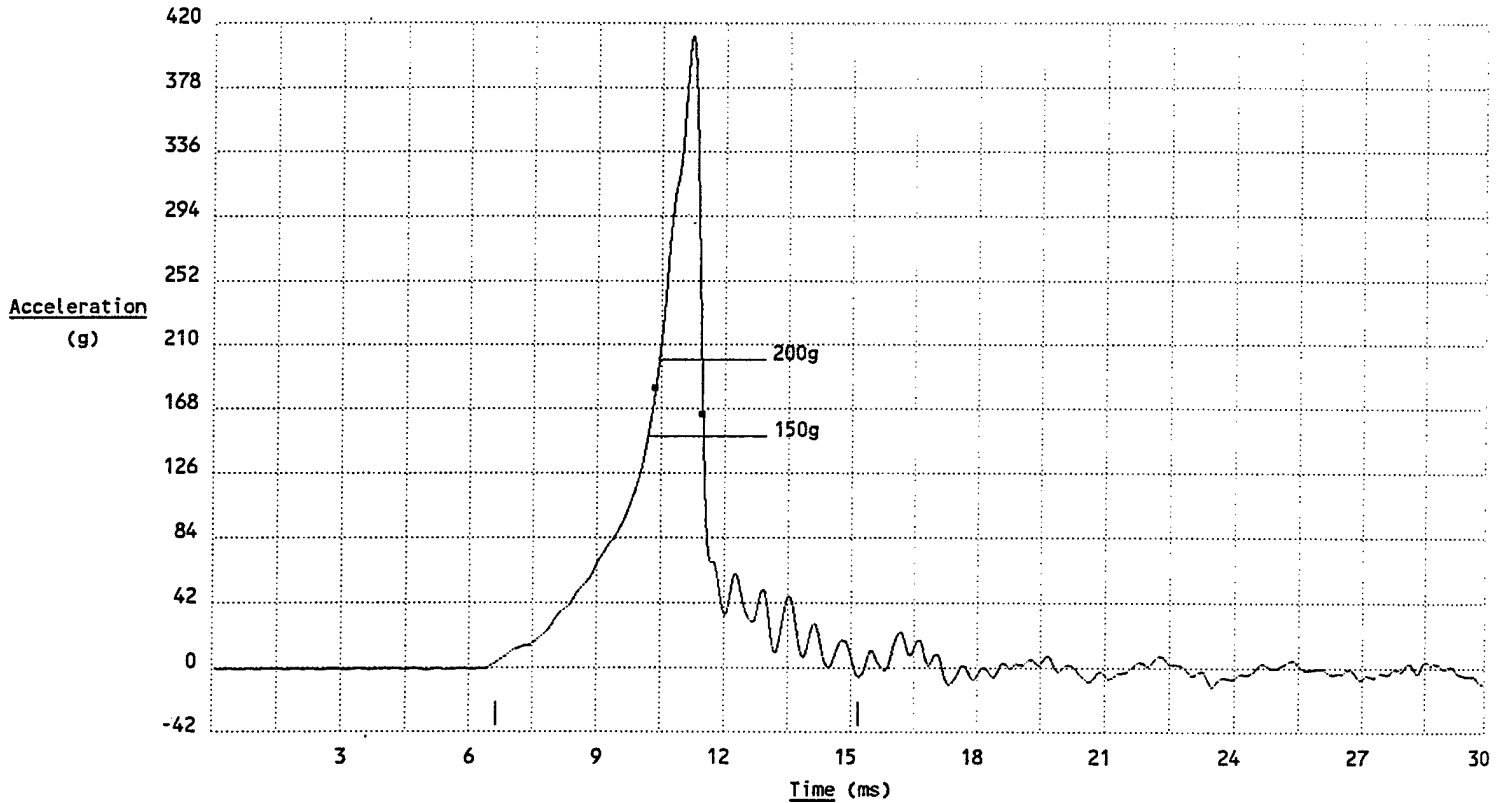

Sample #: #2 (SPECIAL INSERT)

Model: PROTEC

Impact Site: LEFT SIDE

Impact Energy: 65 J

Drop Height: 1.2 M

Anvil: STEEL FLAT

Headform: ISO 'J'

Conditioning Temp.: 23C

Impact Velocity: 4.83 m/s

Peak Acceleration: 412.4 g

Area: 0.735 gs

Time to peak: 4.67 ms

Pulse width: 8.53 ms

H.I.C.: 1750.7 (between 10.3 ms and 11.5 ms)

Time above 150g: 1.3 ms

Time above 200g: 1.0 ms

DATE: 04-02-1998

ACCELERATION vs TIME

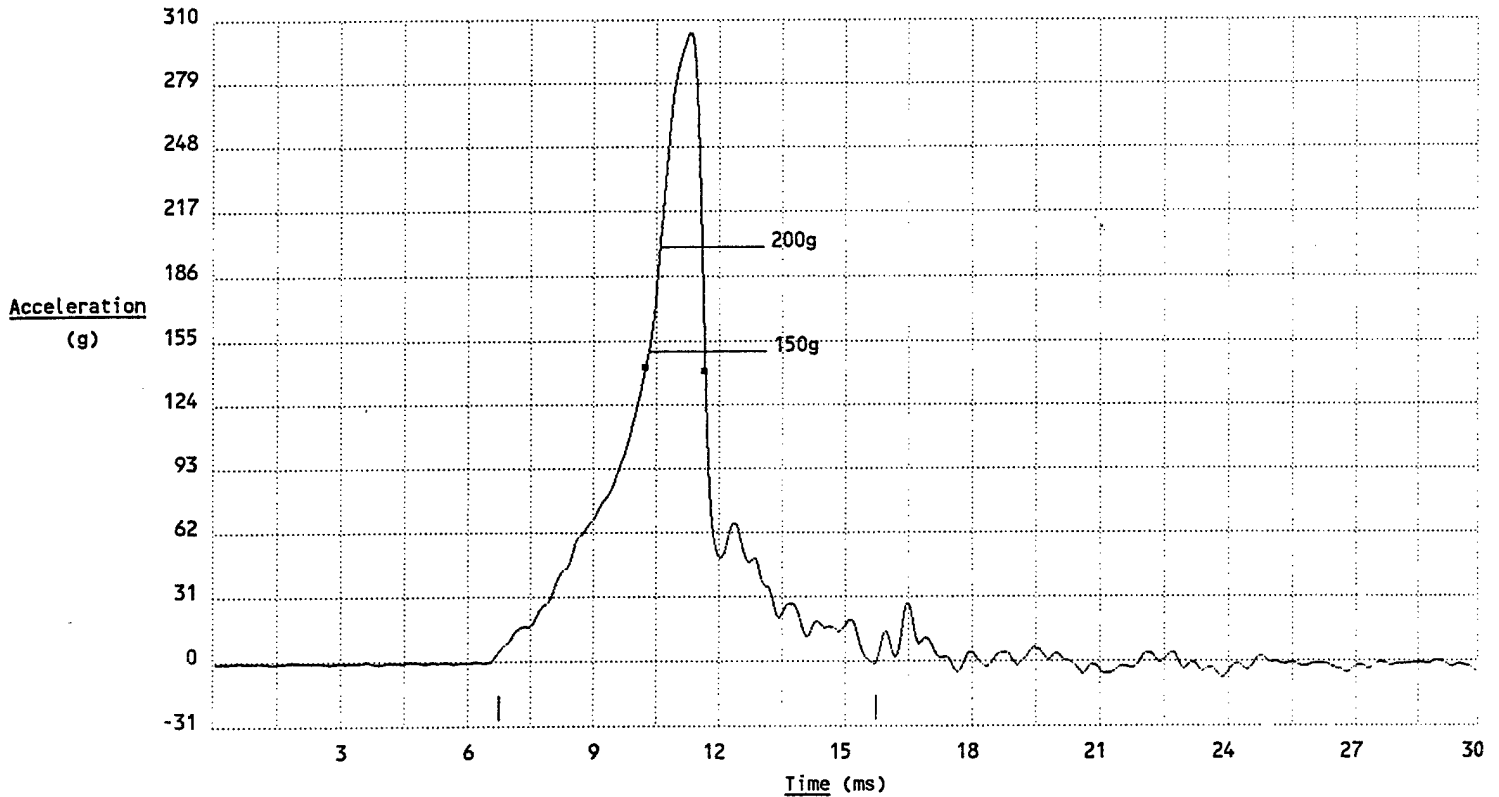

Sample #: #2 (SPECIAL INSERT)

Model: PROTEC

Impact Site: RIGHT SIDE

Impact Energy: 65 J

Drop Height: 1.2 M

Anvil: STEEL FLAT

Headform: ISO 'J'

Conditioning Temp.: 23C

Impact Velocity: 4.83 m/s

Peak Acceleration: 304.7 g

Area: 0.713 gs

Time to peak: 4.68 ms

Pulse width: 8.99 ms

H.I.C.: 1252.5 (between 10.2 ms and 11.6 ms)

Time above 150g: 1.3 ms

Time above 200g: 1.0 ms

DATE: 04-02-1998