

UNITED STATE AIR FORCE  
SUMMER RESEARCH PROGRAM -- 1993  
SUMMER RESEARCH PROGRAM FINAL REPORTS

VOLUME 16

ARNOLD ENGINEERING DEVELOPMENT CENTER  
FRANK J. SEILER RESEARCH LABORATORY  
WILFORD HALL MEDICAL CENTER

RESEARCH & DEVELOPMENT LABORATORIES

5800 Uplander Way  
Culver City, CA 90230-6608

Program Director, RDL  
Gary Moore

Program Manager, AFOSR  
Col. Hal Rhoades

Program Manager, RDL  
Scott Licoscas

Program Administrator, RDL  
Gwendolyn Smith

Program Administrator, RDL  
Johnetta Thompson

DISTRIBUTION STATEMENT A:  
Approved for Public Release -  
Distribution Unlimited

Submitted to:

AIR FORCE OFFICE OF SCIENTIFIC RESEARCH

Bolling Air Force Base

Washington, D.C.

December 1993

Reproduced From  
Best Available Copy

19981127 093

**REPORT DOCUMENTATION PAGE**

Public reporting burden for this collection of information is estimated to average 1 hour per response, including and maintaining the data needed, and completing and reviewing the collection of information. Send comments and suggestions for reducing this burden, to Washington Headquarters Services, Directorate for Information Operations and Reports, 1220 North 17th Street, Arlington, VA 22202-4302, and to the Office of Management and Budget, Paperwork Reduction Project (0704-0188), Washington, DC 20503.

**AFRL-SR-BL-TR-98-**

0766

Department of  
Aeronautics and  
Space Administration,  
Washington, DC, Suite  
3033

1. AGENCY USE ONLY (Leave Blank)		2. REPORT DATE December, 1993	3. REPORT TYPE AND PERIOD Final
4. TITLE AND SUBTITLE USAF Summer Research Program - 1993 High School Apprenticeship Program Final Reports, Volume 16, AEDC, FJSRL, and WHMC			5. FUNDING NUMBERS
6. AUTHORS Gary Moore			
7. PERFORMING ORGANIZATION NAME(S) AND ADDRESS(ES) Research and Development Labs, Culver City, CA			8. PERFORMING ORGANIZATION REPORT NUMBER
9. SPONSORING/MONITORING AGENCY NAME(S) AND ADDRESS(ES) AFOSR/NI 4040 Fairfax Dr, Suite 500 Arlington, VA 22203-1613			10. SPONSORING/MONITORING AGENCY REPORT NUMBER
11. SUPPLEMENTARY NOTES Contract Number: F4962-90-C-0076			
12a. DISTRIBUTION AVAILABILITY STATEMENT Approved for Public Release			12b. DISTRIBUTION CODE
13. ABSTRACT (Maximum 200 words) The United States Air Force High School Apprenticeship Program's (USAF- HSAP) purpose is to place outstanding high school students whose interests are in the areas of mathematics, engineering, and science to work in a laboratory environment. The students selected to participate in the program work in an Air Force Laboratory for a duration of 8 weeks during their summer vacation.			
14. SUBJECT TERMS AIR FORCE HIGH SCHOOL APPRENTICESHIP PROGRAM, APPRENTICESHIP, AIR FORCE RESEARCH, AIR FORCE, ENGINEERING, LABORATORIES, REPORTS, SCHOOL, STUDENT, SUMMER, UNIVERSITIES			15. NUMBER OF PAGES
			16. PRICE CODE
17. SECURITY CLASSIFICATION OF REPORT Unclassified	18. SECURITY CLASSIFICATION OF THIS PAGE Unclassified	19. SECURITY CLASSIFICATION OF ABSTRACT Unclassified	20. LIMITATION OF ABSTRACT UL

**DTIC QUALITY INSPECTED 3**

# Master Index For High School Apprentices

Ackermann, Laura  
7801 Wilshire NE  
La Cueva High School  
Albuquerque, NM 87122-0000

Laboratory: PL/LI  
Vol-Page No: 13- 5

Alexanderson, Sarah  
7173 FM 1628  
East Central High School  
San Antonio, TX 78263-0000

Laboratory: AL/HR  
Vol-Page No: 12-25

Antonson, Stephan  
800 Cypress St.  
Rome Catholic High School  
Rome, NY 13440-0000

Laboratory: RL/IR  
Vol-Page No: 14-12

Arnold, Katherine  
1400 Jackson-Keller  
Robert E. Lee High School  
San Antonio, TX 78213-0000

Laboratory: AL/OE  
Vol-Page No: 12-30

Baits, Mark  
248 North Main Street  
Cedarville High School  
Cedarville, OH 45314-0000

Laboratory: WL/FI  
Vol-Page No: 15-11

Baker, Eugenia  
501 Mosely Dr.  
A. Crawford Mosley High School  
Lynn Haven, FL 32444-0000

Laboratory: AL/EQ  
Vol-Page No: 12-19

Bakert, Jonathan  
Oneida St.  
Sauquoit Valley Central High S  
Sauquoit, NY 13456-0000

Laboratory: RL/ER  
Vol-Page No: 14- 7

Banaszak, Brian  
9830 W. National Rd.  
Tecumseh High School  
New Carlisle, OH 45344-0000

Laboratory: WL/PO  
Vol-Page No: 15-44

Barber, Jason  
1000 10th St.  
Floresville High School  
Floresville, TX 78114-0000

Laboratory: AL/CF  
Vol-Page No: 12- 8

Bautista, Jennifer

Laboratory: WL/MN  
Vol-Page No: 15-26

## HSAP Participant Data

Behm, Jessica  
3301 Shroyer Rd.  
Kettering Fairmont High School  
Kettering, OH 45429-0000

Laboratory: WL/ML  
Vol-Page No: 15-21

Berty, Sara  
4524 Linden Ave.  
Carroll High School  
Dayton, OH 45432-0000

Laboratory: AL/OE  
Vol-Page No: 12-31

Blanchard, William

Laboratory: WL/MN  
Vol-Page No: 15-27

- 0

Bond, Ryan  
North Jackson St.  
Tullahoma High School  
Tullahoma, TN 37388-0000

Laboratory: AEDC/  
Vol-Page No: 16- 1

Bowlby, Andrea  
Mudge Way  
Bedford High School  
Bedford, MA 1730-0000

Laboratory: PL/GP  
Vol-Page No: 13- 1

Brecht, Jason  
5400 Chambersburg Road  
Wayne High Achool  
Huber Heights, OH 45424-0000

Laboratory: WL/FI  
Vol-Page No: 15-12

Brown, David  
12200 Lomas Blvd. NE  
Manzano High School  
Albuquerque, NM 87112-0000

Laboratory: PL/WS  
Vol-Page No: 13-19

Cabral, Aaron  
800 Odelia NE  
Albuquerque High School  
Albuquerque, NM 87102-0000

Laboratory: PL/SX  
Vol-Page No: 13-13

Camero, Lisa  
2515 Navajo St.  
South San Antonio High School  
San Antonio, TX 78224-0000

Laboratory: AL/AO  
Vol-Page No: 12- 2

Campanile, Nicholas  
2660 Dayton-Xenia Rd.  
Beavercreek High School  
Beavercreek, OH 45434-0000

Laboratory: WL/EL  
Vol-Page No: 15- 7

## HSAP Participant Data

Carranza, Jason 505 S. Ludlow St. Chaminade-Julienne High School Dayton, OH 45402-0000	Laboratory: WL/AA Vol-Page No: 15- 1
Carroll, Shawn 1400 Jackson Keller St. Robert E. Lee High School San Antonio, TX 78213-0000	Laboratory: AL/CF Vol-Page No: 12- 9
Casares, Carmen 1215 N. St. Mary's Providence High School San Antonio, TX 78215-0000	Laboratory: AL/AO Vol-Page No: 12- 3
Cayton, Sabrina 5005 Stahl Rd. James Madison High School San Antonio, TX 78247-0000	Laboratory: AL/AO Vol-Page No: 12- 4
Chuang, Eleanore 2660 Dayton-Xenia Rd. Beavercreek High School Beavercreek, OH 45434-0000	Laboratory: AL/CF Vol-Page No: 12-10
Ciomperlik, Kara 7173 FM 1628 East Central High School San Antonio, TX 78263-0000	Laboratory: AL/OE Vol-Page No: 12-32
Cook, Theresa  - 0	Laboratory: WL/MN Vol-Page No: 15-28
Cosgrove, Kathlyn 727 E. Hildebrand Incarnate Word High School San Antonio, TX 78284-0000	Laboratory: AL/CF Vol-Page No: 12- 5
Dalley, Kevin 2660 Dayton-Xenia Rd. Beavercreek High School Beavercreek, OH 45434-0000	Laboratory: WL/AA Vol-Page No: 15- 2
Danelo, David 25 Burwood St. San Antonio Christian School San Antonio, TX 78216-0000	Laboratory: AL/HR Vol-Page No: 12-26

## HSAP Participant Data

Davis, James  
1000 School Ave.  
Rutherford High School  
Panama City, FL 32404-0000

Laboratory: AL/EO  
Vol-Page No: 20

DeBrosse, Nick  
3301 Shroyer Rd.  
Kettering Fairmont High School  
Kettering, OH 45429-0000

Laboratory: WL/PO  
Vol-Page No: 15-45

Decker, Michael  
2601 Oneida St.  
Sauquoit Valley Central School  
Sauquoit, NY 13456-0000

Laboratory: RL/ER  
Vol-Page No: 14- 8

Deibler, Nancy

Laboratory: WL/MN  
Vol-Page No: 15-29

- 0

Dodsworth, Christopher  
4916 National Rd.  
Northmont High School  
Clayton, OH 45315-0000

Laboratory: WL/EL  
Vol-Page No: 15- 8

Dominguez, Janette  
114 E. Gerald Ave.  
Harlandale High School  
San Antonio, TX 78214-0000

Laboratory: AL/HR  
Vol-Page No: 12-27

Ellena, Brandon  
711 Anita Dr.  
Tehachapi High School  
Tehachapi, CA 93561-0000

Laboratory: PL/RK  
Vol-Page No: 13- 9

Ethridge, Blake  
7801 Wilshire Blvd.  
La Cueva High School  
Albuquerque, NM 87122-0000

Laboratory: PL/LI  
Vol-Page No: 13- 6

Felderman, James  
N. Jackson St.  
Tullahoma High School  
Tullahoma, TN 37388-0000

Laboratory: AEDC/  
Vol-Page No: 16- 2

Feucht, Danny  
5833 Student St.  
West Carrollton High School  
West Carrollton, OH 45418-0000

Laboratory: WL/FI  
Vol-Page No: 15-13

## HSAP Participant Data

Finch, David 501 Niagara Ave. Colonel White High School Dayton, OH 45405-0000	Laboratory: AL/OE Vol-Page No: 12-33
Focht, Jeremy 2660 Dayton-Xenia Rd. Beavercreek High School Beavercreek, OH 45434-0000	Laboratory: WL/ML Vol-Page No: 15-22
Foley, Jennifer 2660 Dayton-Xenia Rd. Beavercreek High School Beavercreek, OH 45434-0000	Laboratory: WL/EL Vol-Page No: 15- 9
Foth, Angela 501 Mosley Dr. A. Crawford Mosley High School Lynn Haven, FL 32444-0000	Laboratory: AL/EQ Vol-Page No: 12-21
Fowler, Brendon Chenango Ave. Clinton Senior High School Clinton, NY 13323-0000	Laboratory: RL/C3 Vol-Page No: 14- 2
Garcia, Stephanie 650 Ingram Oliver Wendell Holmes San Antonio, TX 78238-0000	Laboratory: AL/AO Vol-Page No: 12- 6
Garcia, Alejandro 2515 Navajo St. South San Antonio High School San Antonio, TX 78224-0000	Laboratory: AL/CF Vol-Page No: 12-11
Garcia, Andrea 6701 Fortuna Rd. NW West Mesa High School Albuquerque, NM 87121-0000	Laboratory: PL/SX Vol-Page No: 13-14
Gavornik, Jeffrey 5110 Walzem Rd. Roosevelt High School San Antonio, TX 78239-0000	Laboratory: AL/CF Vol-Page No: 12-12
Giles, Mark 1204 Harrison Ave. Bay High School Panama City, FL 32401-0000	Laboratory: AL/EQ Vol-Page No: 12-22

## HSAP Participant Data

Ginger, David  
500 E. Franklin St.  
Centerville High School  
Centerville, OH 45459-0000

Laboratory: WL/ML  
Vol-Page No: 15-23

Gonzalez, Christopher  
1400 Jackson-Keller  
Robert E. Lee High School  
San Antonio, TX 78234-0000

Laboratory: AL/OE  
Vol-Page No: 12-34

Gooden, Christie

Laboratory: WL/MN  
Vol-Page No: 15-30

, - 0

Grabowski, Holly  
Shawsheen Rd.  
Andover High School  
Andover, MA 1810-0000

Laboratory: RL/ER  
Vol-Page No: 14- 9

Gurecki, David  
800 Cypress St.  
Rome Catholic High School  
Rome, NY 13440-0000

Laboratory: RL/C3  
Vol-Page No: 14- 1

Hanna, Melissa  
1312 Utica St.  
Oriskany Central High School  
Oriskany, NY 13424-0000

Laboratory: RL/IR  
Vol-Page No: 14-13

Harrison, Deanna

Laboratory: WL/MN  
Vol-Page No: 15-31

, - 0

Hartsock, David  
3491 Upper Bellbrook Rd.  
Bellbrook High School  
Bellbrook, OH 45305-0000

Laboratory: WL/PO  
Vol-Page No: 15-46

Hayduk, Eric  
800 Cypress St.  
Rome Catholic High School  
Rome, NY 13440-0000

Laboratory: RL/OC  
Vol-Page No: 14-16

Hemmer, Laura

Laboratory: WL/MN  
Vol-Page No: 15-32

, - 0

## HSAP Participant Data

Hill, Thuan  
North Jackson St.  
Tullahoma High School  
Tullahoma, TN 37388-0000

Laboratory: AEDC/  
Vol-Page No: 16- 3

Hodges, Melanie  
5833 Student St.  
West Carrollton High School  
West Carrollton, OH 45418-0000

Laboratory: WL/PO  
Vol-Page No: 15-47

Jeffcoat, Mark

Laboratory: WL/MN  
Vol-Page No: 15-33

- 0

Jost, Tiffany  
Lincoln Rd.  
Lincoln-Sudbury Regional High  
Sudbury, MA 1776-0000

Laboratory: PL/GP  
Vol-Page No: 13- 2

Kitty, Alexandra  
3900 W. Peterson  
Our Lady of Good Counsel High  
Chicago, IL 60659-3199

Laboratory: PL/RK  
Vol-Page No: 13-10

Kozlowski, Peter  
500 E. Franklin St.  
Centerville High School  
Centerville, OH 45459-0000

Laboratory: WL/ML  
Vol-Page No: 15-24

Kress, Barry

Laboratory: WL/MN  
Vol-Page No: 15-34

- 0

Kulesa, Joel  
940 David Rd.  
Archbishop Alter High School  
Kettering, OH 45429-0000

Laboratory: WL/EL  
Vol-Page No: 15-10

Lormand, Bradley  
PO Drawer CC  
Rosamond High School  
Rosamond, CA 93560-0000

Laboratory: PL/RK  
Vol-Page No: 13-11

Maloof, Adam  
251 Waltham St.  
Lexington High School  
Lexington, MA 2173-0000

Laboratory: RL/ER  
Vol-Page No: 14-10

## HSAP Participant Data

Marlow, Chris  
925 Dinah Shore Blvd.  
Franklin County High School  
Winchester, TN 37398-0000

Laboratory: AEDC/  
Vol-Page No: 16- 4

Martin, Amy  
3301 Shroyer Rd.  
Kettering Fairmont High School  
Kettering, OH 45429-0000

Laboratory: WL/FI  
Vol-Page No: 15-15

Matthews, Suzanne  
5323 Montgomery NE  
Del Norte High School  
Albuquerque, NM 87109-0000

Laboratory: PL/SX  
Vol-Page No: 13-15

McEuen, Eric  
800 Odelia Rd. NE  
Albuquerque High School  
Albuquerque, NM 87102-0000

Laboratory: PL/VT  
Vol-Page No: 13-17

McGovern, Scott  
3491 Upper Bellbrook Rd.  
Bellbrook High School  
Bellbrook, OH 45305-0000

Laboratory: WL/AA  
Vol-Page No: 15- 3

McPherson, Sandra  
Jefferson & Grove St.  
Bishop Brossart High School  
Alexandria, KY 41001-0000

Laboratory: WL/ML  
Vol-Page No: 15-25

Menge, Sean  
Route 294  
Adirondack High School  
Boonville, NY 13309-0000

Laboratory: RL/C3  
Vol-Page No: 14- 3

Merrill, Benjamin  
3491 Upper Bellbrook Rd.  
Bellbrook High School  
Bellbrook, OH 45305-0000

Laboratory: WL/FI  
Vol-Page No: 15-16

Middleton, Charles  
4524 Linden Ave.  
Carroll High School  
Dayton, OH 45432-0000

Laboratory: WL/FI  
Vol-Page No: 15-17

Miksch, Virginia  
727 E. Hildebrand  
Incarnate Word High School  
San Antonio, TX 78284-0000

Laboratory: AL/CF  
Vol-Page No: 12-13

## HSAP Participant Data

Moore II, Elliot

Laboratory: WL/MN

Vol-Page No: 15-35

- 0

Mortis, Rebecca

Laboratory: AL/HR

727 E. Hildebrand

Vol-Page No: 12-28

Incarnate Word High School

San Antonio, TX 78284-0000

Morton, Gilbert

Laboratory: AEDC/

2001 McArthur Dr.

Vol-Page No: 16- 5

Coffee County Central High Sch

Manchester, TN 37355-0000

Neitzel, Laura

Laboratory: AL/OE

N. St. Mary's

Vol-Page No: 12-35

Providence High School

San Antonio, TX 78215-0000

Nguyen, Quynhtrang

Laboratory: AL/CF

5833 Student St.

Vol-Page No: 12-14

West Carrollton High School

West Carrollton, OH 45418-0000

Nielsen, Eric

Laboratory: RL/C3

500 Turin Rd.

Vol-Page No: 14- 4

Rome Free Academy

Rome, NY 13440-0000

Northcutt, Chris

Laboratory: AEDC/

925 Dinah Shore Blvd.

Vol-Page No: 16- 6

Franklin County High School

Winchester, TN 37398-0000

Olson, Amanda

Laboratory: AL/EQ

1000 School Ave.

Vol-Page No: 12-23

Rutherford High School

Panama City, FL 32404-0000

Ondrusek, Kimberly

Laboratory: AL/HR

7173 FM 1628

Vol-Page No: 12-29

East Central High School

San Antonio, TX 78263-0000

Ortiz, Benjamin

Laboratory: PL/LI

6701 Fortuna Rd. NW

Vol-Page No: 13- 7

West Mesa High School

Albuquerque, NM 87105-0000

## HSAP Participant Data

Page, Melissa  
501 Mosley Dr.  
A. Crawford Mosley  
Lynn Haven, FL 32444-5609

Laboratory: WL/FI  
Vol-Page No: 15-18

Panara, Michael  
500 Turin St.  
Rome Free Academy  
Rome, NY 13440-0000

Laboratory: RL/C3  
Vol-Page No: 14- 5

Penn, Alexander

Laboratory: WL/MN  
Vol-Page No: 15-36

, - 0

Perry, Kyle  
Crestview High School  
, - 0

Laboratory: WL/MN  
Vol-Page No: 15-37

Pletcher, Mary

Laboratory: WL/MN  
Vol-Page No: 15-38

, - 0

Pletl, Anne  
Burrstone Rd.  
Notre Dame  
Utica, NY 13502-0000

Laboratory: RL/C3  
Vol-Page No: 14- 6

Prevost, Daniel  
3301 Shroyer Rd.  
Kettering Fairmont High School  
Kettering, OH 45429-0000

Laboratory: WL/PO  
Vol-Page No: 15-48

Price, Kristy  
North Jackson St.  
Tullahoma High School  
Tullahoma, TN 37388-0000

Laboratory: AEDC/  
Vol-Page No: 16- 7

Protz, Christopher  
501 Mosley Dr.  
A. Crawford Mosley High School  
Lynn Haven, FL 32444-5609

Laboratory: AL/EQ  
Vol-Page No: 12-24

Rader, Thomas  
1505 Candelaria NW  
Valley High School  
Albuquerque, NM 87107-0000

Laboratory: PL/WS  
Vol-Page No: 13-20

## HSAP Participant Data

Ray, Kristopher  
401 Eagle Blvd.  
Shelbyville Central High School  
Shelbyville, TN 37160-0000

Laboratory: AEDC/  
Vol-Page No: 16- 8

Reed, Tracy  
711 Anita Dr.  
Tehachapi High School  
Tehachapi, CA 93561-0000

Laboratory: PL/RK  
Vol-Page No: 13-12

Riddle, Cheryl  
Highway 55  
Moore County High School  
Lynchburg, TN 37352-0000

Laboratory: AEDC/  
Vol-Page No: 16- 9

Rodriguez, Luis  
5400 Chambersburg Rd.  
Wayne High School  
Huber Heights, OH 45424-0000

Laboratory: AL/CF  
Vol-Page No: 12-15

Rosenbaum, David

Laboratory: WL/MN  
Vol-Page No: 15-39

- 0

Salinas, Carol  
727 E. Hildebrand  
Incarnate Word High School  
San Antonio, TX 78212-0000

Laboratory: AL/CF  
Vol-Page No: 12-16

Schanding, Sarah  
7173 FM 1628  
East Central High School  
San Antonio, TX 78162-0000

Laboratory: AL/CF  
Vol-Page No: 12-17

Schatz, William  
500 Turin St.  
Rome Free Academy  
Rome, NY 13440-0000

Laboratory: RL/IR  
Vol-Page No: 14-14

Schindler, David  
Drawer 1300  
Los Lunas High School  
Los Lunas, NM 87031-0000

Laboratory: PL/LI  
Vol-Page No: 13- 8

Senus, Joe  
500 Turin St.  
Rome Free Academy  
Rome, NY 13440-0000

Laboratory: RL/IR  
Vol-Page No: 14-15

## HSAP Participant Data

Servaites, Jonathan 500 E. Franklin St. Centerville High School Centerville, OH 45459-0000	Laboratory: WL/PO Vol-Page No: 15-49
Shao, Min 869 Massachusetts Ave. Arlington High School Arlington, MA 2174-0000	Laboratory: PL/GP Vol-Page No: 13- 3
Simon, Ryan 701 E. Home Rd. Springfield North High School Springfield, OH 45503-0000	Laboratory: AL/OE Vol-Page No: 12-36
Smith, Adam  Phillips Academy Andover, MA 1810-0000	Laboratory: PL/GP Vol-Page No: 13- 4
Solscheid, Jill 500 E. Franklin St. Centerville High School Centerville, OH 45459-0000	Laboratory: AL/OE Vol-Page No: 12-37
Spry, David 555 N. Hyatt St Tippecanoe High School Tipp City, OH 45371-0000	Laboratory: WL/PO Vol-Page No: 15-50
Starr, Jennifer 221 E. Trotwood Blvd. Trotwood Madison Sr. High Scho Trotwood, OH 45426-0000	Laboratory: WL/AA Vol-Page No: 15- 4
Strickland, Jefferey 501 Mosley Dr. A. Crawford Mosley High School Lynn Haven, FL 32444-0000	Laboratory: WL/FI Vol-Page No: 15-19
Tecumseh, Tony 5323 Montgomery NE Del Norte High School Albuquerque, NM 87110-0000	Laboratory: PL/VT Vol-Page No: 13-18
Terry, Nathan 75 Chenango Ave. Clinton High School Clinton, NY 13323-0000	Laboratory: RL/ER Vol-Page No: 14-11

## HSAP Participant Data

Thomson, Randy

Laboratory: WL/MN  
Vol-Page No: 15-40

, - 0

Triana, Zayda  
727 E. Hildebrand  
Incarnate Word High School  
San Antonio, TX 78212-2598

Laboratory: AL/AO  
Vol-Page No: 12- 7

Trossbach, Christina

Laboratory: WL/MN  
Vol-Page No: 15-41

, - 0

Tseng, Miranda  
3301 Shroyer Rd.  
Kettering Fairmont High School  
Kettering, OH 45429-0000

Laboratory: WL/FI  
Vol-Page No: 15-20

Tutin, Darcie

Laboratory: WL/MN  
Vol-Page No: 15-42

, - 0

Vaill, Christopher  
Route 31  
Vernon-Verona-Sherrill Central  
Verona, NY 13478-0000

Laboratory: RL/OC  
Vol-Page No: 14-17

Ward, Jon

Laboratory: WL/MN  
Vol-Page No: 15-43

, - 0

Waterman, Sara  
North Jackson St.  
Tullahoma High School  
Tullahoma, TN 37388-0000

Laboratory: AEDC/  
Vol-Page No: 16-10

Weidner, Suzanne  
7173 FM 1628  
East Central High School  
San Antonio, TX 78263-0000

Laboratory: AL/OE  
Vol-Page No: 12-38

West, Johnny  
2026 Stapleton Court  
Belmont High School  
Dayton, OH 45404-0000

Laboratory: WL/AA  
Vol-Page No: 15- 5

## HSAP Participant Data

Wick, Matthew  
6400 Wyoming Blvd.  
Albuquerque Academy  
Albuquerque, NM 87109-0000

Laboratory: PL/WS  
Vol-Page No: 13-21

Williams, Scott  
3511 Dayton-Xenia Rd.  
Beavercreek High School  
Beavercreek, OH 45434-0000

Laboratory: WL/AA  
Vol-Page No: 15- 6

Wright, Rudy  
6701 Fortuna Rd. NW  
West Mesa High School  
Albuquerque, NM 87121-0000

Laboratory: PL/SX  
Vol-Page No: 13-16

Young, Matthew  
5005 Stahl Rd.  
James Madison High School  
San Antonio, TX 78247-0000

Laboratory: AL/OE  
Vol-Page No: 12-39

Zimmerman, Amy  
4524 Linden Ave.  
Carroll High School  
Dayton, OH 45432-0000

Laboratory: AL/CF  
Vol-Page No: 12-18

THE POSSIBLE TIME REDUCTION OF CFD SOLUTIONS  
RESULTING FROM GRID SEQUENCING

Ryan B. Bond

Student

Tullahoma High School  
1001 North Jackson Street  
Tullahoma, TN 37388

Final Report for:

High School Apprenticeship Program  
Arnold Engineering Development Center

Sponsored by:

Air Force Office of Scientific Research  
Arnold Air Force Base, TN

August 1993

THE POSSIBLE TIME REDUCTION OF CFD SOLUTIONS  
RESULTING FROM GRID SEQUENCING

Ryan B. Bond  
Student  
Tullahoma High School

Abstract

Grid sequencing, a technique used to reduce run times of solutions in computational fluid dynamics, was studied. A technique was developed to determine the time at which the solution should be transferred from one grid to another. The technique produced sequences that were either the fastest sequence or very close to the fastest sequence on multiple flow solvers using inviscid calculations. The method by which data is transferred from one grid to another was also tested. It was found that , for the inviscid calculations, use of the fourth order interpolator and the linear interpolator produced results with insignificant differences in the same number of iterations.

THE POSSIBLE TIME REDUCTION OF CFD SOLUTIONS  
RESULTING FROM GRID SEQUENCING

Ryan B. Bond

ACKNOWLEDGMENTS

The author would like to thank Stacey G. Rock and Dr. Robert H. Nichols for their guidance and assistance on this work. The author would also like to thank the Air Force Office of Scientific Research, Arnold Engineering Development Center, and Arvin Calspan Corp. for support of the research.

INTRODUCTION

Computational fluid dynamics (CFD) is a link between two fields of engineering, fluid mechanics and computational field simulation. Fluid mechanics is the study of all fluid flow fields, and computational field simulation is a rapidly growing area of engineering that has been enhanced by the development of supercomputers and advanced workstations. Computational field simulation is the representation of any continuous field in a computer by a set of points in a region of three dimensional space. The points have values for certain physical characteristics of the simulated field. These values vary from point to point and develop over time as dictated by the various mathematical techniques involved in computational field simulation.

The physical laws that govern the behavior of continuous mediums can be expressed mathematically by systems of partial differential equations that relate the values assigned to a point to the values of surrounding points. Since the computer cannot solve equations expressed in infinitesimal calculus, the system of partial differential equations must be replaced by a larger set

of algebraic equations. The algebraic equations are only approximations of the partial differential equations. These approximations are most accurate when they are used to relate the values of a point to the values of nearby points. If the system is solved for each point, the result is not the final representation of the physical field, but a closer approximation. The system must be solved repeatedly until a steady state, or converged, solution is reached (i.e. one that exhibits insignificant change upon further computation of the values of the system of points throughout the physical field). Since the partial differential equations have been expressed as a set of algebraic equations, a time step ( $\Delta t$ ) must be set to evaluate the problem. The smaller the time step used, the longer the solution takes to reach convergence; however, if a time step too large is chosen, the values will not be evaluated properly. This steady state solution is the final solution of a continuous physical field.

Since a region of three dimensional space contains an infinite number of points, a complete description of a flow field would involve an infinite amount of data. This would call for an infinite amount of calculations to be done in order to reach a converged solution. Therefore, in order to make the calculations feasible, it is necessary to develop a grid, or mesh, containing a finite number of points. The grid with the most points is capable of producing the most accurate approximation of the flow field, but the grid with the fewest amount of points is capable of producing a solution in the least amount of time, since fewer calculations must be carried out. This addresses the first compromise involved in any computational field simulation, the one between speed and accuracy. The methods used in CFD were known for quite some time before they could be applied to actual problems. The speed and volume of

computations available using supercomputers made application of the complex mathematical sets possible.<sup>1</sup>

The set of partial differential equations that model viscous fluid flow are known as the Navier-Stokes equations. The Navier-Stokes equation set is very large and very complex, so one compromise between speed and accuracy involves reducing the Navier-Stokes set to a smaller set. One way of doing this is to compute an inviscid solution, rather than a viscous one. The most general flow configuration for an inviscid, non-heat-conducting fluid is described by the set of Euler equations. The Euler equations are derived from the Navier-Stokes equations by neglecting all shear stresses and heat conduction terms. Euler calculations are less accurate than Navier-Stokes calculations, but they are acceptable for flow at high Reynolds numbers in areas outside of the viscous regions along the surfaces of a solid model placed within the flow.

The set of Navier-Stokes equations requires assistance from other sets of equations to calculate certain characteristics of the flow. These sets are called turbulence models. The size and complexity of turbulence models can greatly affect both the accuracy and speed of the flow solver; thus another compromise must be reached between speed and accuracy. Turbulence models range from simple algebraic models to first or second order models which are more complex.<sup>2</sup>

Since accuracy must be compromised for speed in so many areas of the simulation, any technique that reduces time can be used to increase accuracy. Increasing the speed of reaching the solution allows the compromises to be re-evaluated in order to increase the accuracy of the flow solver. One such method is called grid sequencing. Grid sequencing is performed by using

multiple grids in different stages of the solution development to analyze one problem. Each successive grid contains more points than its predecessor in the sequence. The finer grid produces a more accurate solution, but it takes more time to complete the same number of iterations. A finer mesh can possibly converge faster if its initial data comes from a rougher representation of the flow field rather than a set of free stream conditions. The rougher solution can be produced by a coarser mesh. In some cases, the final same solution can be produced in less time using grid sequencing. To generate the grids for the series, a program can be written to alter the finest desired grid by throwing out every other point in one or more dimensions. The process can be repeated until the desired number of grids have been generated.

Data must be transferred from one grid to another by analyzing the solution on the current grid and transferring it onto the next grid in the sequence. In the first step of this process, all the grid points that exist on the previous grid are given the same values for each parameter as their corresponding points on the previous grid. The points that are unique to the newer grid are given values for each parameter by one of several methods. One method is a linear interpolation using only adjacent points. Other methods involve higher order interpolations which make use of more surrounding points. While grid sequencing has been proven to reduce the time to convergence on some problems, a best method of executing a grid sequence has not previously been determined.

The time at which the solution is transferred from one grid to another can influence the outcome of a sequence greatly. The purpose of this study was to develop a method that can approximate the optimum time to transition

the grids in a grid sequence and to determine the best method of transferring data from one grid to another.

#### EQUIPMENT

Two flow solving codes were used in this study. One code, XLIM, was used during the development of the method for finding the ideal grid transition point(s). XLIM is capable of solving either the Euler or the Navier-Stokes equations, but since its time to convergence was so long for the inviscid case, it was not used to test the methods capability to determine the ideal transition point for the viscous case. Another code, OVERFLOW<sup>3</sup>, was used to test the method of finding the ideal grid sequencing transition point for both the viscous and inviscid cases. Both codes use Euler calculations for inviscid flow and Navier-Stokes calculations for viscous flow. OVERFLOW uses a Baldwin-Lomax<sup>2</sup> turbulence model. OVERFLOW uses multiple input files to change the time step as the flow field solution approaches convergence. In the inviscid calculations for each sequence,  $\Delta t$  was set equal to one for the first fifty iterations, two for the second fifty iterations, and four for the remainder of the iterations necessary to reach convergence. In the viscous calculations,  $\Delta t$  was set equal to one for the first 100 iterations, then set equal to two for the remainder of the sequence. The time step was not changed after the introduction of a new grid into the sequence. For XLIM, the time step was set equal to ten for all calculations.

The aerodynamic model used in the calculations was a NACA 0012 airfoil<sup>4</sup> with unit chord length = 1. The model was at an angle of attack of three degrees. The free stream Mach number for the inviscid calculations on the

model was 0.75. The Mach number was the same for the viscous calculations, and the Reynold's number was  $3.3 \times 10^6$ .

The coarse grid used on the inviscid calculations with XLIM was  $77 \times 17 \times 5$ , and the one used with OVERFLOW was  $77 \times 17 \times 3$ . XLIM requires a minimum of five planes to simulate two dimensional flow. OVERFLOW requires three planes to simulate two dimensional flow. The intermediate inviscid grid had dimensions  $153 \times 33 \times 5$  for XLIM and  $153 \times 33 \times 3$  for OVERFLOW. The fine grids for XLIM and OVERFLOW were  $305 \times 65 \times 5$  and  $305 \times 65 \times 3$  respectively. The viscous grids contained the same number of points as the inviscid grids; however, on the viscous grid the points are distributed differently to aid in the development of the boundary layer.

#### PROCEDURE

The convergence histories of three existing inviscid grids for a NACA 0012 airfoil were obtained using the XLIM code; then several random sequences were executed. On the random sequences, the fine grid was not allowed to converge; its time to convergence was estimated using the previously acquired convergence history. The information obtained from the convergence histories and the random sequences was used to develop several methods that could possibly determine the optimum grid transition points between each grid in the series. Several factors, including the residuals and forces, were analyzed to see if they could be used to determine the best possible grid transition time. Examining the residual and the lift coefficient ( $C_L$ ) led to the development of several methods. All the methods produced sequences that converged in a significantly lower time than the unsequenced fine grid, but one method involving the lift coefficient produced the fastest sequence.

The method which produced the fastest sequence involved both the ratio of the number of points in the successive grids in the sequence and the  $dC_L$  (the rate of change of the lift coefficient). The only difference in two successive grids in a sequence is the number of points in the grids, so the method of producing the fastest sequence must involve this factor. In certain flow problems (i.e. airfoils and store separation problems), the forces can give a good indication of when the flow has reached a converged solution, and also how fast the flow is approaching the converged solution. The  $dC_L$  term proved a good indicator of the speed at which the solution approached convergence, so it was used in the method. Since the flow solver itself does not compute the forces, another program was employed. The forces were only measured at certain intervals, so the mathematical representation of the method involves the  $\Delta C_L$  (the change in the lift coefficient over a number of iterations) term rather than the  $dC_L$  term. To relate the  $\Delta C_L$  to the ratio of the number of grid points, the  $\Delta C_L$  term was first divided by the  $C_L$  term to produce a unitless number. Since the frequency of  $C_L$  measurements affects the magnitude of the  $\Delta C_L$  term, the number was then divided by the number of steps between each  $C_L$  measurement (1 step = 1 iteration x  $\Delta t$ ). This produced a number that was no longer unitless, so it was multiplied by the total number of steps to convergence of the finest grid. This value was defined as the grid transition index. The formula relating the terms is shown in equation 1.

$$(1) \left| \frac{\Delta C_L \times (\text{total \# of steps to convergence of fine grid})}{C_L \times \Delta \text{steps}} \right| = \frac{\text{\# of points in first grid}}{\text{\# of points in second grid}}$$

↑
↑

grid transition index
grid point ratio

where:

$$1 \text{ step} = 1 \text{ iteration} \times \Delta t$$

The curve of the grid transition index vs. iterations was always exponential for the inviscid calculations on XLIM (Figure 1 and Figure 2).

Since the method was developed on the XLIM flow solver for inviscid flow, its applicability was tested using the OVERFLOW code for both inviscid and viscous solutions. In both cases, several sequences were run to observe the nature of the code, then the method was tested by changing from the first grid to the second grid where the method predicted (within ten iterations), and then varying the transition point by ten iterations in both directions while holding the transition point between the second and third grids constant. Then, the time to convergence was evaluated using the transition point between the second and third grid that the method predicted and varying it by ten iterations in both directions while holding the transition point between the first and second grid constant. All sequences were allowed to converge completely before being evaluated.

To test the method of transferring information from one grid to another, the results of a sequence using a linear interpolator and an identically proportioned sequence using a fourth order interpolator were compared.

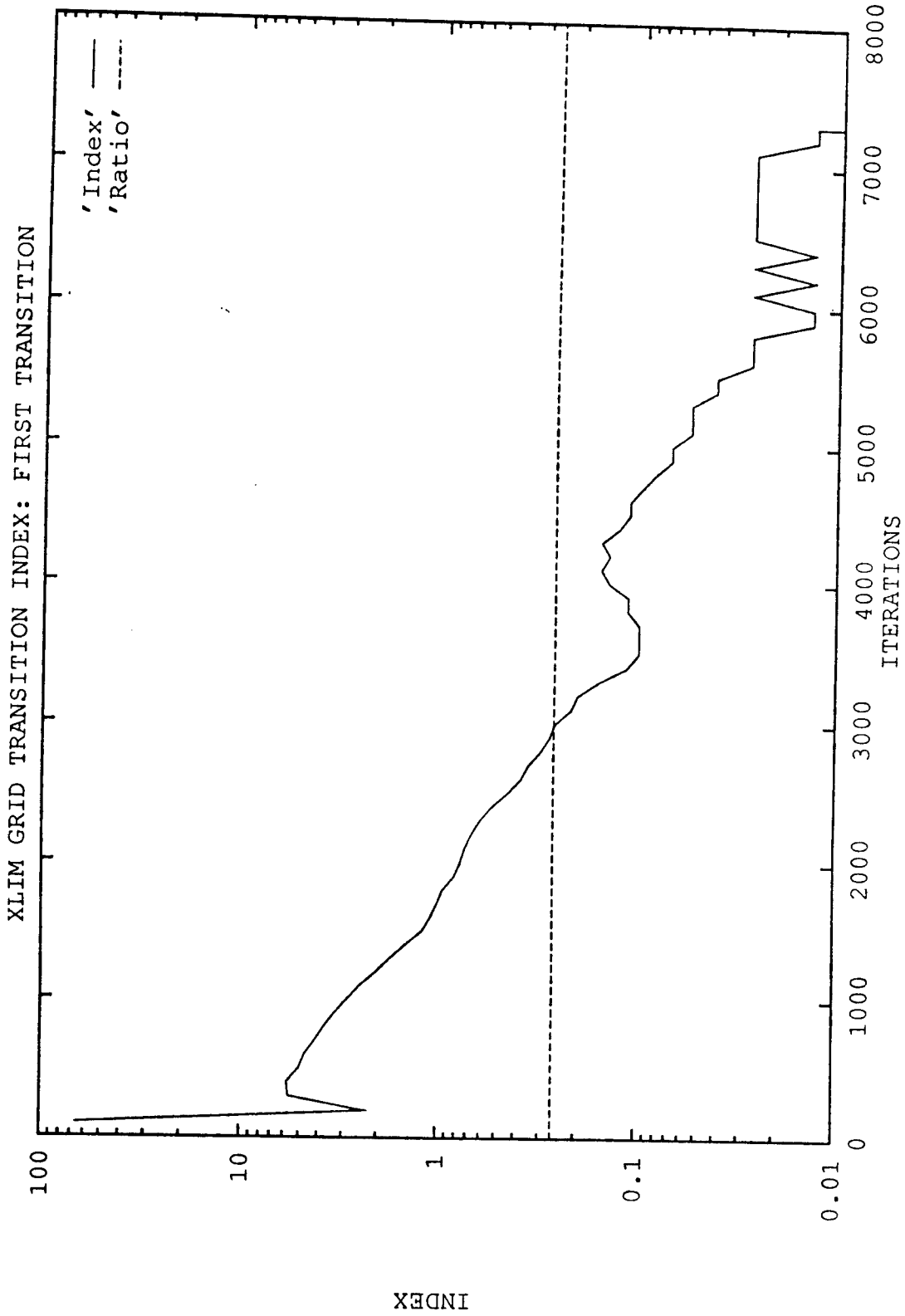

Figure 1

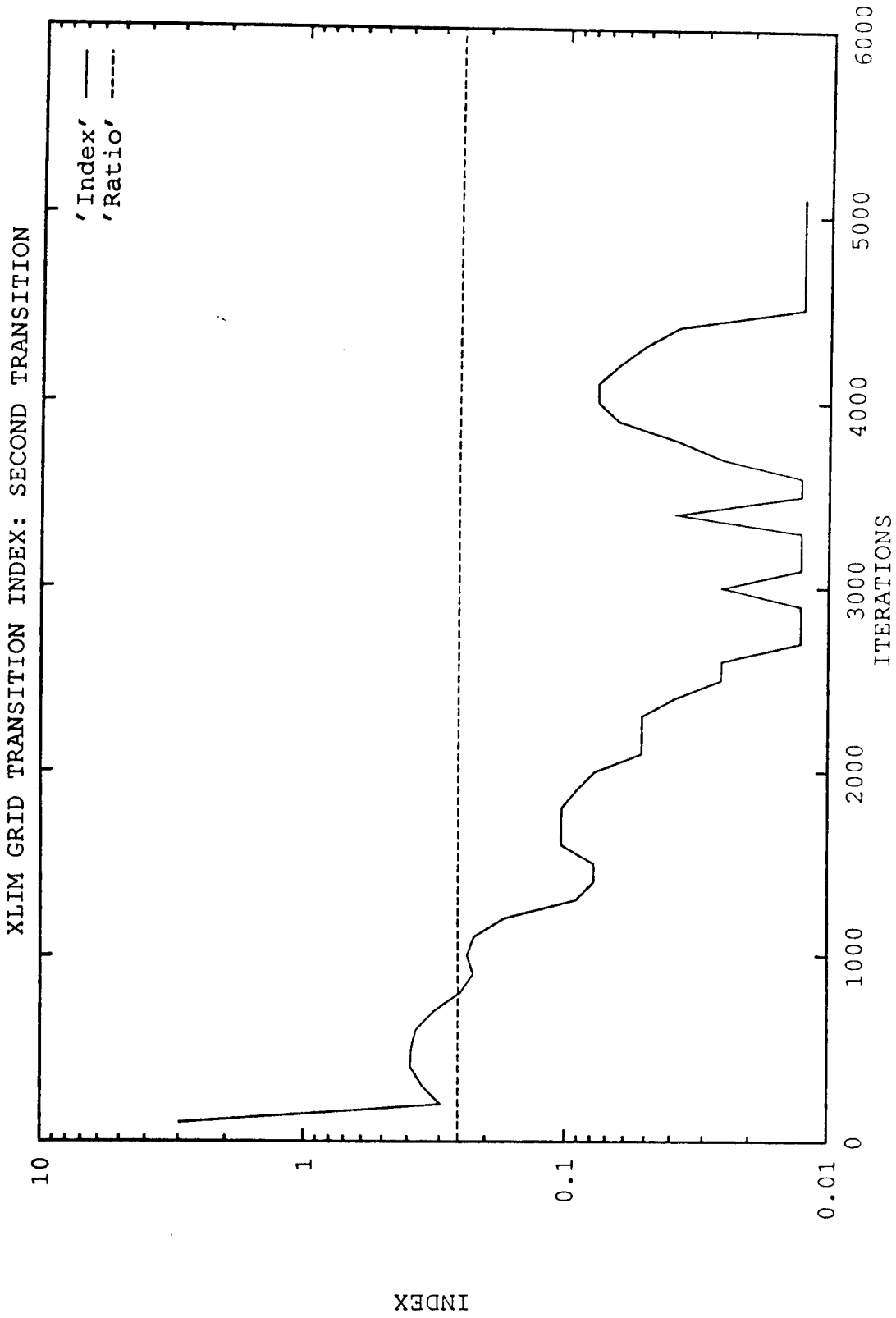

Figure 2

## RESULTS

The graph of the grid transition index vs. iterations for the coarse grid on the OVERFLOW code (Figure 3) was not as smooth of an exponential curve as the graph of the index on the XLIM code. The long term trend in the values of the index was still exponential, but the index values rose and fell dramatically. The reason that the index values fell dramatically in some places is that the lift coefficient curve did not behave logarithmically like the  $C_L$  curve for the XLIM convergence histories. The  $C_L$  curve did approach the final  $C_L$  value asymptotically, but it crossed through the value several times. This created several peaks and troughs where the curve leveled off. If the  $C_L$  values were taken at infinitesimal increments, the  $dC_L$  value would have reached zero in each of these areas. A  $dC_L$  value of zero would indicate that the solution was not moving toward convergence at a rate measurable by the accuracy of the  $C_L$  measurements. The lift coefficient values then would begin moving again. This would indicate that the speed at which the solution was approaching convergence was rising and lowering, which is mathematically impossible. To make the data usable it was modified and then used to influence a smooth exponential curve. If an index value was obtained that was higher than any preceding value, the assumption was made that the higher value was a better indication of the speed at which the solution was approaching convergence. All the preceding points with smaller values were eliminated upon the collection of each data point (this kept the peaks and troughs in the  $C_L$  curve from influencing the index curve). The data was taken and modified in the following manner:

1.  $C_L$  values were taken every five iterations after the final  $\Delta t$  change was implemented.

OVERFLOW GRID TRANSITION INDEX: FIRST TRANSITION

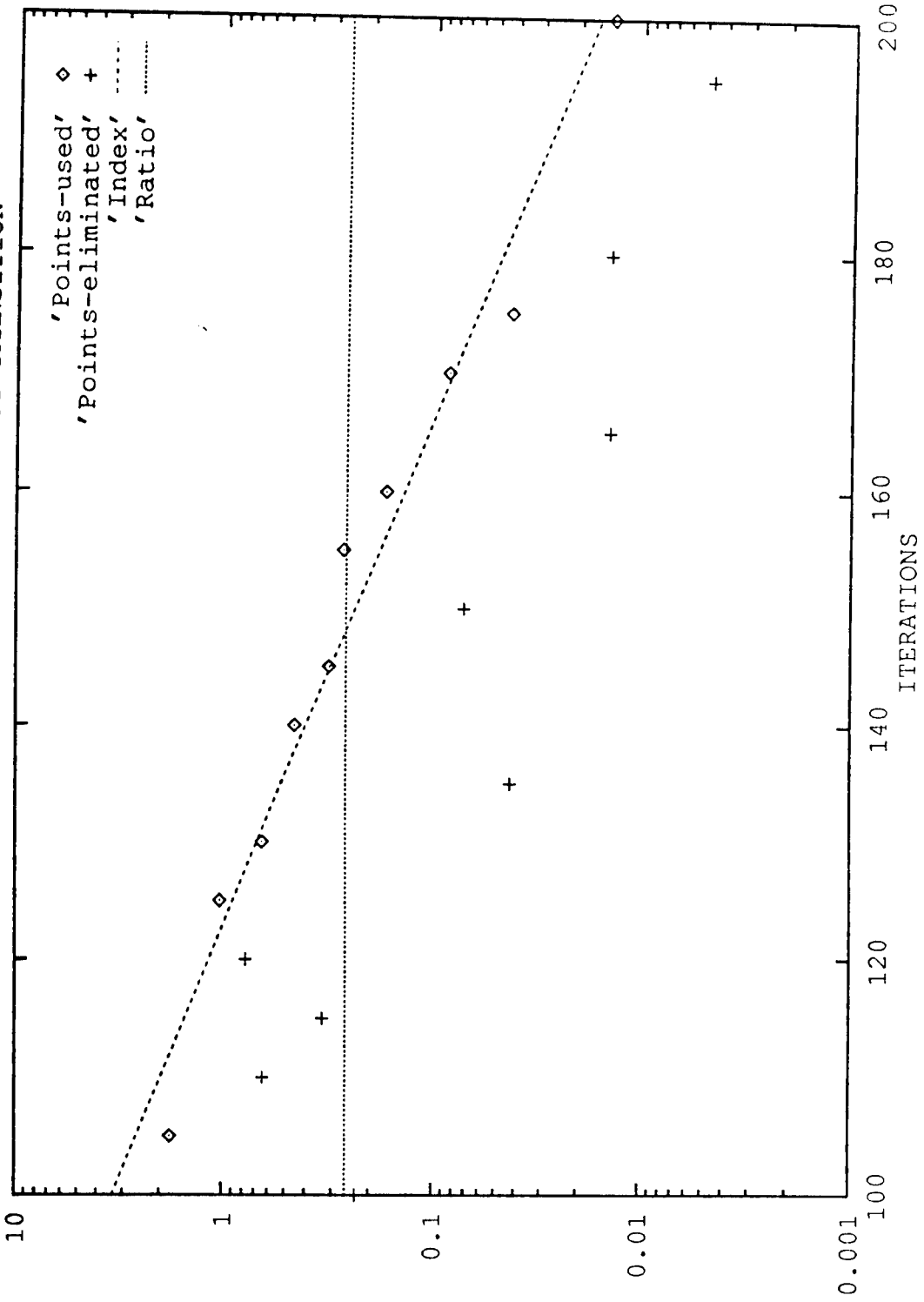

INDEX

Figure 3

2. The grid transition index was calculated for each value of the  $C_L$ .
3. If a value of the index was greater than any previous values of the index, those previous values were eliminated.
4. An exponential curve was drawn using the remaining data points.
5. The values of the exponential curve were compared to the grid point ratio to determine where the method predicted the best transition time.

Figure 3 shows all the data points that were allowed to influence the curve, all the terminated data points, the curve itself, and a line representing the grid point ratio. The curve predicted that the transition between meshes should occur around 150 iterations. The transition between the second and third grid was kept stationary while the transition between the first and second grid was altered. Table 1 shows the sequence designed using the method (Sequence B) and the sequences where the grid change was altered by ten iterations to both sides.

SEQUENCE	ITERATIONS FOR COARSE GRID	ITERATIONS FOR INTERMEDIATE GRID	ITERATIONS TO CONVERGENCE FOR FINE GRID	TOTAL CPU TIME
A	140	20	260	54:07.8
B	150	20	230	48:17.5
C	160	20	220	46:25.1
D	170	20	260	54:28.4

Table 1

All times were computed using averages of many different runs of 100 iterations each.

Since the sequence designed using the method took more CPU time (user time) to converge than the sequence with the transition at a later time, another sequence was used to determine if the optimum transition point would

occur even later. A sequence with the first grid transition at 170 iterations was executed, and its results are shown above.

The times from this table indicated that the CPU time to convergence was higher for this sequence than for the fastest tested sequence and the sequence designed using the method. The data seemed to indicate that the fastest possible sequence with the second transition point held constant at 20 iterations is the one in which the first transition point occurs between 50 and 60 iterations, but closer to sixty. The Figure 4 shows the CPU times for the four sequences listed in the tables above.

*First Transition Variation*

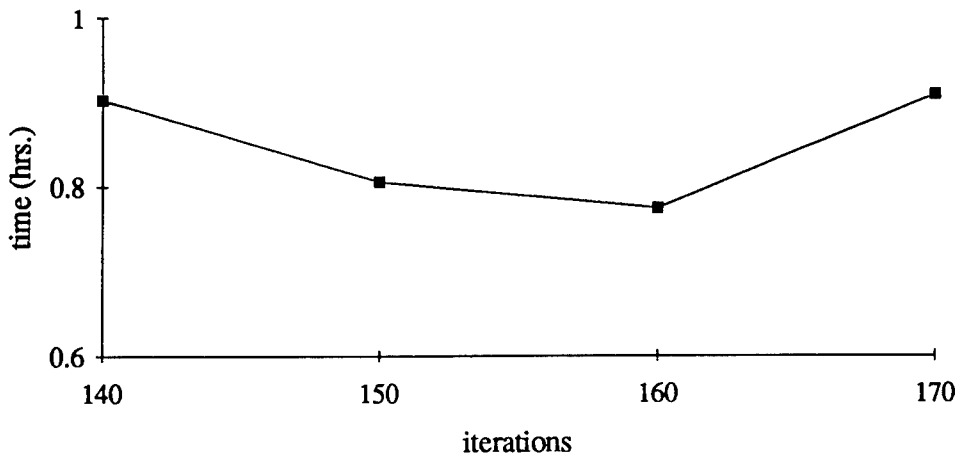
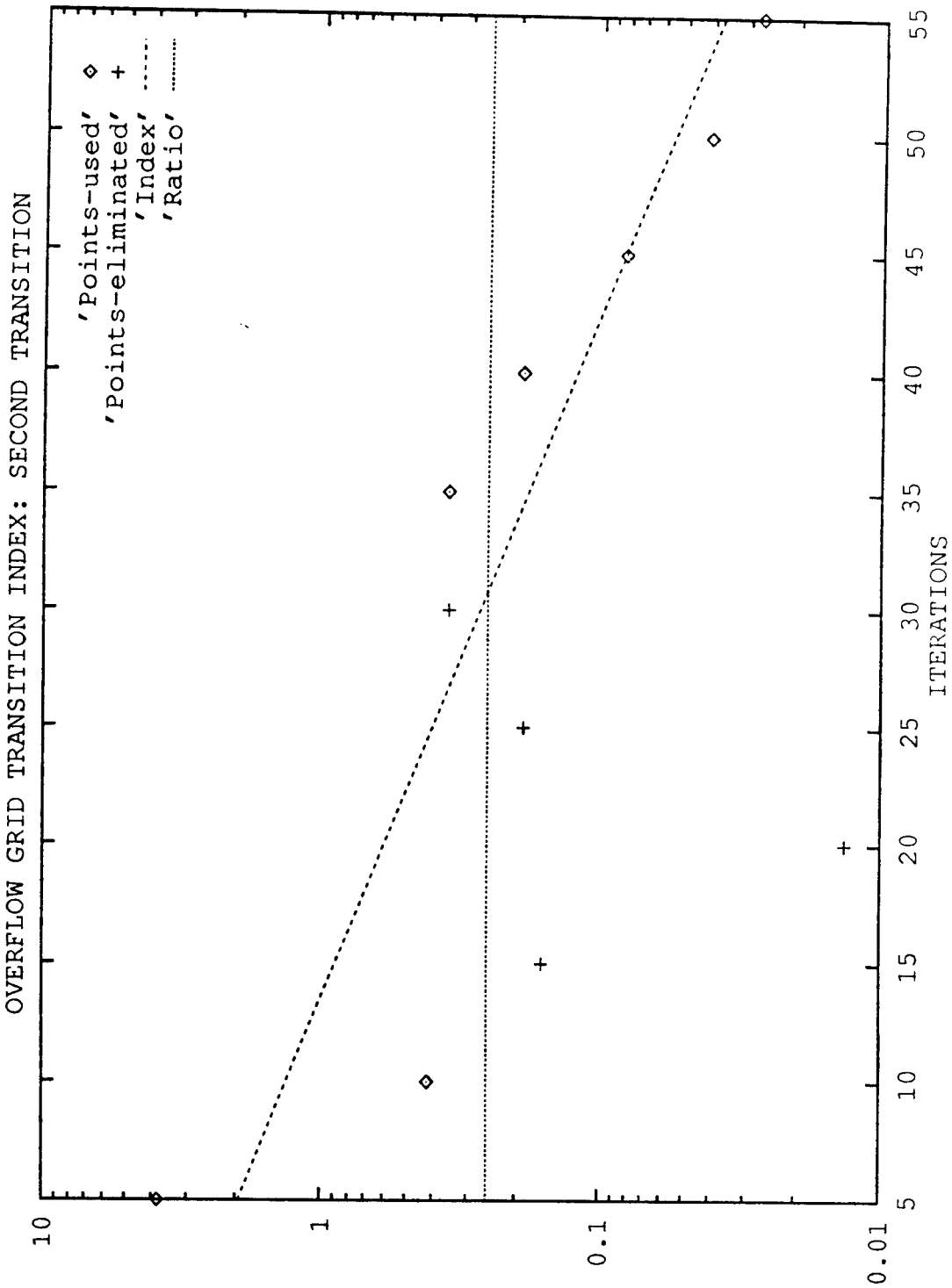

Figure 4

Figure 5 shows where the method predicted the second transition point should be when the first transition point was fixed at 150 iterations. The curve predicted that the transition between meshes should occur around thirty iterations. The transition between the first and second grid was kept stationary while the transition between the second and third grid was altered. Table 2 shows the sequence designed using the method (Sequence F) and the sequences where the grid change was altered by ten iterations to both sides.



INDEX

Figure 5

SEQUENCE	ITERATIONS FOR COARSE GRID	ITERATIONS FOR INTERMEDIATE GRID	ITERATIONS TO CONVERGENCE FOR FINE GRID	TOTAL CPU TIME
E	150	20	230	48:17.5
F	150	30	220	46:46.1
G	150	40	250	53:11.2

Table 2

The CPU times indicated that the transition point of 30 iterations for the second grid was the optimum place. The exact point appears to be between 20 and 30, but closer to 30. The Figure 6 shows the data contained in the above tables.

**Second Transition Variation**

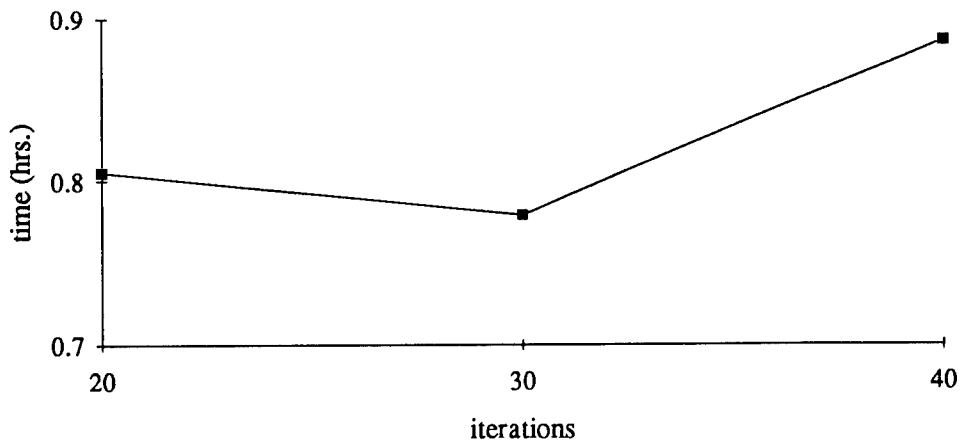

Figure 6

The results of the testing of the two different interpolating methods are contained in Table 3. For inviscid solutions, the linear interpolator seemed to introduce a small amount of error into the solution, but this error was insignificant after the fine grid had been run through all the iterations required to reach convergence.

SEQUENCE	FLOW SOLVER	INTERPOLATOR	ITERATIONS ON COARSE GRID	ITERATIONS ON INTERMEDIATE GRID	ITERATIONS TO CONVERGENCE ON FINE GRID
H	XLIM	LINEAR	3700	1200	1670*
I	XLIM	FOURTH ORDER	3700	1200	1670*
J	OVERFLO W	LINEAR	150	30	220
K	OVERFLO W	FOURTH ORDER	150	30	220

\* THESE SEQUENCES WERE RUN 1000 ITERATIONS, THEN THE REMAINING NUMBER OF ITERATIONS WAS ESTIMATED USING THE RESIDUAL AND THE FORCES

Table 3

### CONCLUSIONS

The method developed to predict the sequence with the lowest CPU time worked very well for inviscid flow patterns. The first predicted transition point that was tested gave a CPU time only 4% slower than the fastest sequence tested with the second mesh change held at 20 iterations. The fastest possible sequence was estimated to have its first transition somewhere between 150 and 160 iterations, and the method indicated that the grids should be changed at 150 iterations. The sequence designed using the method to determine the second mesh transition gave the fastest time of any sequence tested. These results indicate that the method should be effective on multiple flow solvers for inviscid solutions.

For this problem, using inviscid calculations, the method of transferring data from one mesh to another makes insignificant difference in the time taken for the solution to converge on the fine grid.

## REFERENCES

1. Ronald D. Levine. "Supercomputers," Scientific American, January 1982.  
New York: Scientific American, Inc.
2. Charles Hirsch. Numerical Computation of Internal and External Flows,  
Volumes 1 & 2. Chichester: John Wiley and Sons, 1990.
3. Pieter G. Buning, William M. Chan, Kevin J. Renze, douglas L. Sondak, Ing-  
Tsau Chiu, and Jeffrey P. Slotnick. "OVERFLOW User's Manual Version  
1.6ag." 30 April 1993.
4. R. J. Vidal, P. A. Catlin, and D. W. Chudyk. "Two-Dimensional Subsonic  
Experiments with a NACA 0012 Airfoil," Calspan Report No. RK-5070-A-3.

THE MODIFICATION OF A FACILITY DISPLAY  
AND RECORDING SYSTEM

James Cory Felderman  
Graduate, Tullahoma High School  
Freshman Electrical Engineering Student  
Carnegie Mellon University  
Pittsburgh, PA 15213

Mentor: Steven G. Lodholz  
Sverdrup Technology, Inc.

Final Report for:  
AFOSR Summer Research Program

Sponsored by:  
Air Force Office of Scientific Research  
Bolling Air Force Base, Washington, D.C.  
and  
Arnold Engineering Development Center  
Arnold Air Force Base, TN 37389

August 1993

THE MODIFICATION OF A FACILITY DISPLAY  
AND RECORDING SYSTEM

James Cory Felderman  
Graduate, Tullahoma High School  
Freshman Electrical Engineering Student  
Carnegie Mellon University

Abstract

The possible methods of improving the software of a facility display and recording system for the study of jet engine tests were analyzed. The process was begun by reading through the code already written in order to become familiar with the main objectives of the system. Necessary changes and modifications were coded into the programs so that they would be better suited for the testing of turbine engines. In order to accomplish these adjustments, FoxPro 2.0 and QuickBASIC 4.5 handbooks were consulted. Eventually, the programs were adjusted to be more user-friendly and self-explanatory: Few instructions to the users of the programs were necessary, and all that was essential for the displaying and recording of turbine test data was added to the programs.

### Acknowledgments

At this time, I would like to extend a special thanks to Steve Lodholz, my mentor, who provided me with an enjoyable and, above all, an enriching experience. With the additional effort put into his work schedule in order to compensate for an apprentice and to be a hand of guidance, he was able to teach me countless things which will be of much help in years to come as I pursue a career in a field comparable to his. In addition, I would like to show my appreciation for all of those who work along with Steve by thanking them for overlooking the many times I was in their way when I followed Steve as he explained to me his particular tasks and the things electrical engineers should know. Finally, I would like to thank James Mitchell for organizing and administering the High School Apprenticeship Program at AEDC so that I was given the chance to gain experience and knowledge about careers in engineering.

THE MODIFICATION OF A FACILITY DISPLAY  
AND RECORDING SYSTEM

James Cory Felderman

Introduction

The utilization of computers in scientific research has vastly quickened and improved the process of recording and displaying data. In turbine engine testing, computers have proved extremely beneficial for recording, obtaining, and manipulating results. Without the use of computers and their ability to make measurements and calculations in fractions of seconds, much necessary and useful data would be lost. It is advantageous to all involved for the systems utilized in testing to be programmed to meet all the needs of the testing and to be programmed so that they can be run as easily and as quickly as possible. The central problem with adjusting the ASTF facility display and recording system to perform adequately was becoming adept at utilizing programming languages to program efficiently and effectively. This problem was solved in order to allow the facility display and recording system to facilitate the turbine engine testing process.

Background

The facility display and recording system is utilized at the Aeropropulsion Systems Test Facility (ASTF). ASTF is made up of two test cells, C-1 and C-2, for performance and operability testing of large turbojet and turbofan engines. The C Plant at ASTF contains systems that are designed to control the test cell environment and to

simulate realistic flight environment and engine power transients. The ASTF facility display and recording system is a portable data acquisition and display system used to monitor and troubleshoot the various systems in the C Plant. The facility display and recording system is utilized in C Plant, as a device for monitoring test control equipment installed at ASTF. In order to obtain this system, a working copy of the facility display system used for the J4 rocket motor test cell was slightly modified and taken for use at ASTF.

#### Apparatus

The facility display and recording system consists of an 80286-based personal computer equipped with an internal analog to digital convertor card and external signal conditioning equipment. The data acquisition, recording, and display software is written in Microsoft QuickBASIC 4.5, and the database software is written in Microsoft FoxPro 2.0. Necessary handbooks on programming in QuickBASIC 4.5 and FoxPro 2.0 were utilized throughout the modification process.

#### Methodology

The initial step in modifying the original program was acquiring a general idea of its purpose and abilities. The original facility display system was designed to allow the user to visualize several channels of information.

In order for the user to be able to visualize the channel data, an alphagraphic screen was set up. This screen possesses the ability to display eighteen meters (blocks on the screen displaying continuously-

changing readings) sectioned into groups of six with each group shown on a third of the screen; or three graphs, each displayed on a designated third of the screen; or any combination of graphs and groups of six meters. For example, the user could force the screen to display a graph on the first third of the screen and two sections of six meters on the last two thirds of the screen; or he could display two graphs on the first two thirds of the screen and a group of meters on the remaining third of the screen.

Other features of the original facility display and recording system included options for calibrating data and for modifying database files. The option for calibrating data enables the user to manually change the calibration data for each measured channel. Channel data is converted to engineering units (EU) using up to fifth order polynomial expressions derived from the calibration data. The modifying database files option allows the user to choose databases full of measured channel information to be displayed as groups of meters or graphs.

Once the general purpose of the program was understood, additional features were added to augment the abilities of the program. The major addition was addition of calculated parameters. Calculated channel files would allow the user to define channels derived from algebraic calculations with constants and channel data. Calculated channels would then be displayed and recorded with the existing measured channels.

The addition of calculated channel database files called for the creation of options identical to those used when editing, creating, printing, copying, deleting, or designating measured channel files. A new database screen was created to enable the user to choose which

option to use with the calculated channel files and which to use with the measured channel files. The original database screen only allowed for the choice of measured channel file options.

The original system allowed the user to edit or revise measured database files only. With necessary additions, the user could edit database files for calculated channels. This addition required the creation of another screen to be displayed in order to provide the user with a better visual representation of the mathematical setup of the calculated channel file database. Another enhancement enabled the user to create new calculated channel files along with creating new measured channel files. Similar procedures were taken to generate options for the new calculated channel files to be printed, copied, or deleted. However, the creation of another report form, which was cognate to the one used for printing measured channel files, was necessary to permit the user to print calculated channel files.

The original display system allowed the user, along with the aforementioned options, to choose a current measured channel file. The selected file defined the parameter names, units, and equations to be used for EU conversions for each measured channel. The installation of the same type of option, selecting a current calculated channel file, transpired. With this final augmentation, the major change was complete.

Several minor changes were made to enhance the workability of the display system. The most important of all the minor changes was the conversion of all the database files into text files so that the files could be read and displayed.

## Results

After six weeks of programming and consulting manuals, the necessary changes were made to allow the facility display and recording system to meet the immediate needs of ASTF. As can be seen after running the final system (see page 11 for hardcopies of the original run and page 14 for hardcopies of the final run), it is more user-oriented and allows the user more options for testing.

## Observations and Further Learning

It was observed that computer programming can be a very time-consuming and gradual process. Effective debugging tactics may require much experience to obtain. However, with unending determination and the necessary resources, effective programming can be accomplished.

Throughout the modification process, a learning process also took place. The ability to program in FoxPro and QuickBASIC was attained and can be refreshed in the future through the consultation of handbooks-- yet another ability gained. Above all, an increased competence with the handling and usage of computers was achieved.

References

Steven G. Lodholz

Electrical Engineer

Rocket Testing Branch

Sverdrup Technology, Inc.

James D. Mitchell

Flight Dynamics Flight

Technology Division

Test Operations Directorate

# Example of Run from Original System

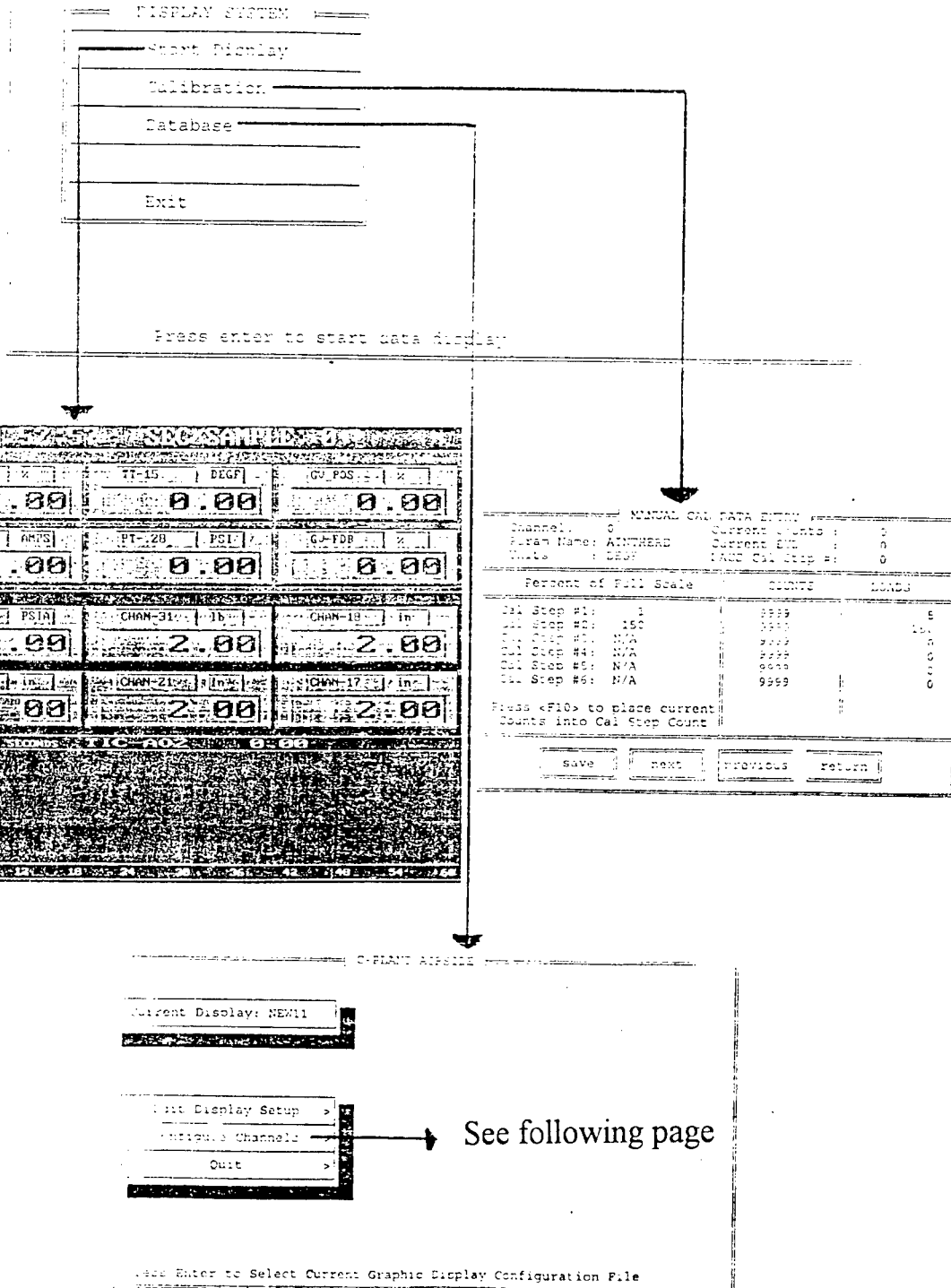

## Configure Channels Option

```

O-PLANT AIRSIDE
Channel Editor

Current Channel Definition File: NEWCH1

Edit Channel Configuration
Create Channel Configuration
Print Channel Configuration
Copy Channel Configuration
Delete Channel Configuration
Quit

Select a channel definition file.

Configure Display System Input Channels.
    
```

```

ASTF001
Number 0
Name AINTHERE
Source XMITTER
Units DEGF
Order 1
Steps
Calstep1 1
Load1 5
Calstep2 150
Load2 150
Calstep3 0
Load3
Calstep4 0
Load4
Calstep5 0
Load5
Calstep6 0
Load6

<F1> = Help <F3> = Print
    
```

# Example of Run from Revised System

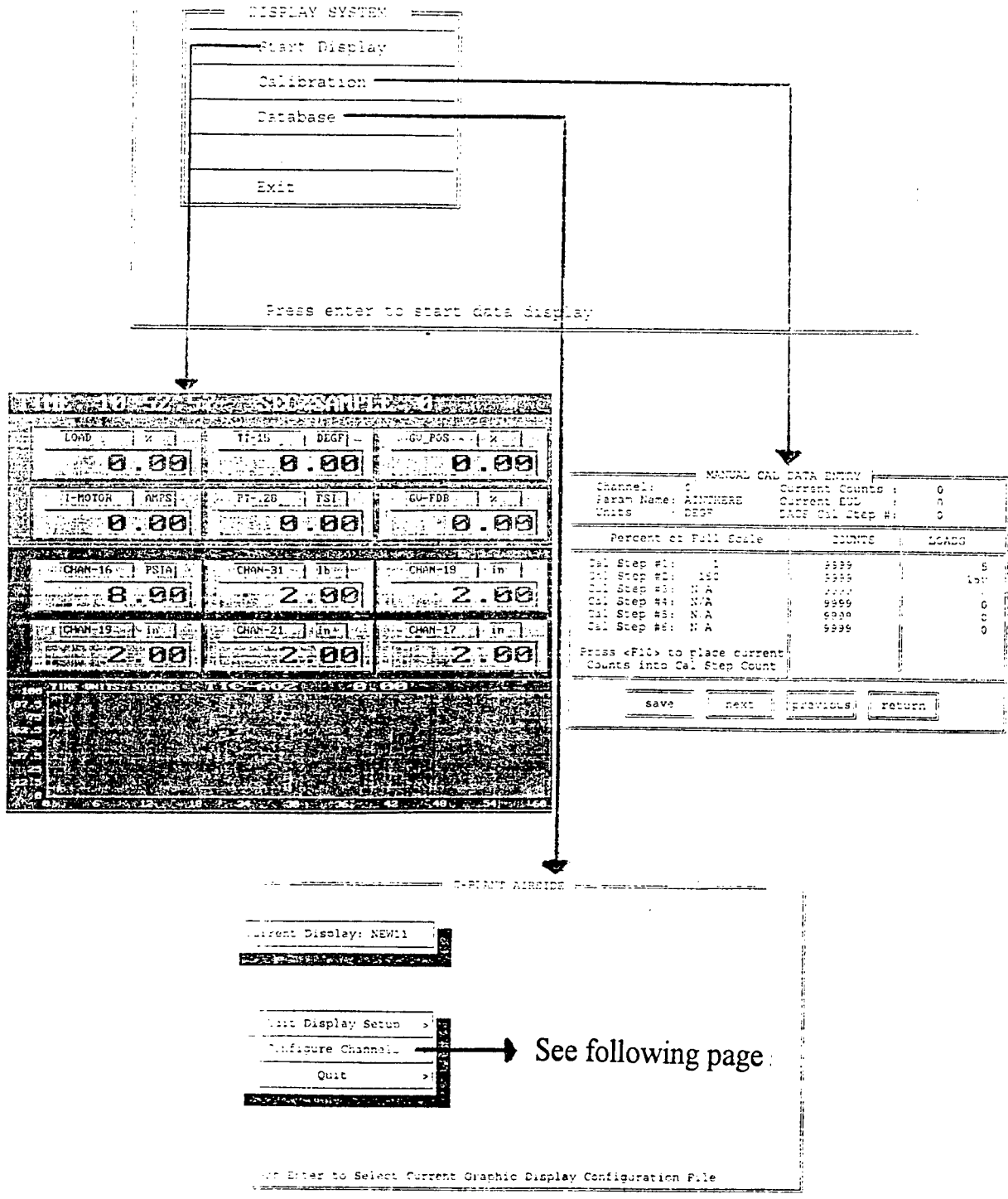

# Configure Channels Option

C-PLANT AIRSIDE  
Channel Editor

Current Measured Channel File: ASTF001  
 Current Calculated Channel File: TEST2

Measured

Edit

---

Create

---

Print

---

Copy

---

Delete

Calculated

Edit

---

Create

---

Print

---

Copy

---

Delete

Quit

Select a measured channel definition file.

Configure Display System Input Channels.

<Esc> = Quit    <PGDN>/<PGUP> = Next/Previous Channel  
 Channel # 16    Name: CHAN-16    Units: psap

	Channel/Constant Operator	
	K	43
	/	/
	K	15
	+	+
	K	1210.00000
	+	+
	K	43
	+	+
	C	2
	+	+
	C	6
	/	/
	K	183.450000
	/	/
	K	2.00

<F1> = Help
<F3> = Print

<Esc> = Quit    ASTF001  
 Number Name    Number

0	AINTHERE	0
1	TT-15	AINTHERE
2	I-MOTOR	Source XMITTER
3	LOAD	Units DEGF
4	GV_POS	Order 1
5	TIC-AO2	Calstep1 1
6	PT-.28	Load1 5
7	PT-34	Calstep2 150
8	GV-FDB	Load2 150
9		Ca'step3 0
10	HGBP-POS	Load3
11	YIC-AO2	Calstep4 0
12		Load4
13		Calstep5 0
14		Load5
15		Calstep6 0
15		Load6

<F1> = Help
<F3> = Print

*J6 Large Rocket Test Facility*  
*Steam System Math Model Validation*

T. Thao Hill

1993 Graduate, Tullahoma High School  
Freshman, Department of Electrical Engineering  
The University of Tennessee College of Engineering  
Knoxville, Tennessee 37996

Mentor: David E. Milleville  
AEDC Sverdrup Technology, Inc.

Final Report for:  
AFOSR Summer Research Program  
Arnold Air Force Base, TN  
Engineering and Analysis Facility

Sponsored by:  
Air Force Office of Scientific Research  
and  
Sverdrup Technology, Inc.  
Arnold Engineering Development Center

August 1993

**J6 Large Rocket Test Facility**

**Steam System Math Model Validation**

T. Thao Hill

1993 Graduate, Tullahoma High School

Freshman, Department of Electrical Engineering

The University of Tennessee College of Engineering

Knoxville, Tennessee 37996

Abstract

The J6 Large Rocket Testing Facility steam system was designed to perform to very specific requirements. A math model for the steam system was developed early in 1993 to provide a tool to be used prior to and during system activation. System data was obtained during a manual blowdown of the system on April 23, 1993. The data was compared to math model simulation data. Results indicated that there was a significant difference between actual and model predicted system performance. Equations of the model were reviewed. Component performances were modified, and the modifications were made in an attempt to be comparable to the real data. In doing so, possible areas of error in the model equations could be detected. These results will be used in the final preparation for activation of the J6 LRTF.

## **J6 Large Rocket Test Facility**

### **Steam System Math Model Validation**

T. Thao Hill

#### Acknowledgments

I would like to offer my deepest appreciation to my mentor, David Milleville, for offering his time and knowledge during my summer program. This type of education has been quite unique, and it would have been impossible without Mr. Milleville's dedication and commitment. The personal treatment and friendship that I have received will be something that I will carry throughout my life. This experience has been educational, exciting, and fun. I would also like to thank Brent Bates, Danny Sells, Barry Bishop, Donna Barnes, Lou Deken, Lynn Sebourn, Rick Burdette, Doug Gerrard, and my neighbor Brian Monroe for making this summer full of work, enrichment, and discussion. Appreciations also are in order to the following people or organizations: Air Force Office of Scientific Research, Arnold Engineering Development Center, AEDC Sverdrup Technology, Inc., and the Analysis Engineering Branch of Sverdrup Tech., EG3.

T. Thao Hill

#### Introduction

Arnold Engineering Development Center's Engine Test Facility (ETF) has been a forerunner in the field of rocket engine testing for decades. Better technology has now allowed these engines to be larger and more powerful; therefore, AEDC, in attempting to maintain top quality and safety, has constructed a new addition to the ETF. The J6 Large Rocket Test Facility is the largest rocket test facility at AEDC (Fig. 1). Unique features of J6 are

many in number, but they are all related to lessons learned from older test facilities. J6 is the combination of all the successes of AEDC rocket testing<sup>1</sup>.

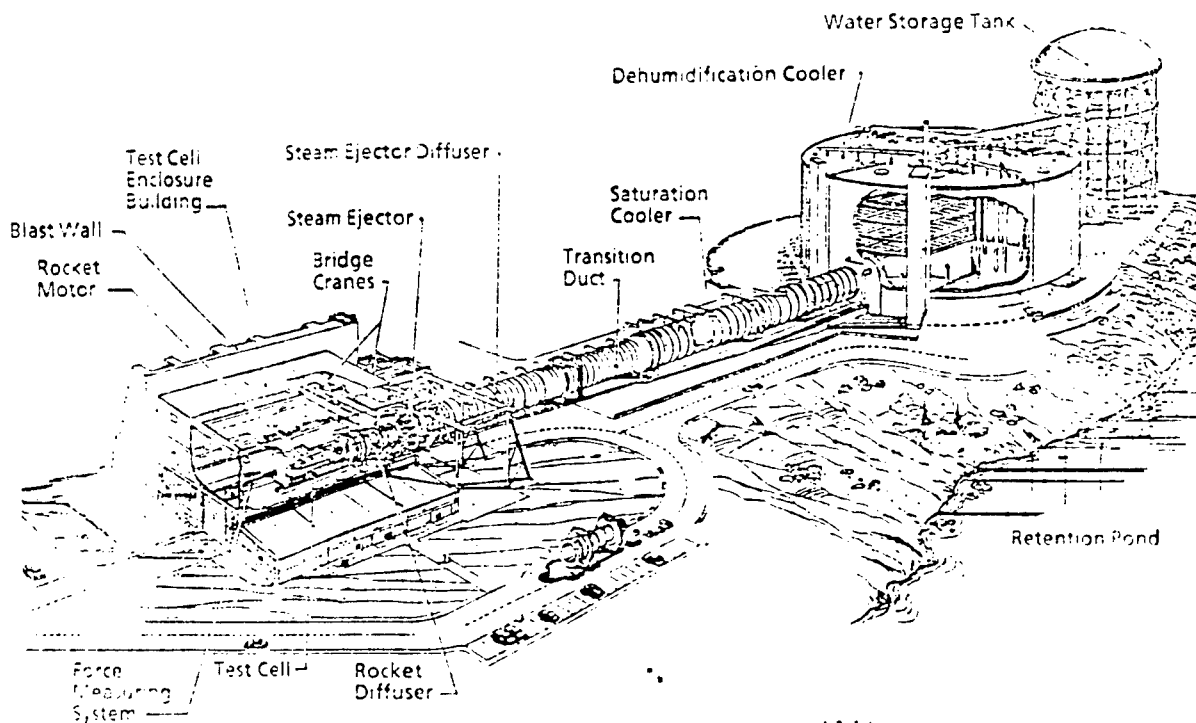

Figure 1. J6 Large Rocket Test Facility

Capability has been provided to test rockets containing up to 100,000 lbs. TNT equivalent of solid propellant and generating up to 500,000 lbs. of thrust<sup>1</sup>. Pressures generated by a rocket motor within the combustion chamber can be quite high. A test cell is incapable of handling such changes in pressure. Also, the rockets will not be flown on ground level, so altitude simulation is integral to a valid rocket test. Because of these problems, devices are needed to set pre-fire and post-fire conditions, gradually changing pressure within the test cell. The steam ejectors do this, and the steam system is the supplier for the ejectors. The steam system provides the ejectors with a determined amount of steam to force the test cell pressure to a desired level. System tests are needed to activate the steam system before

the first motor test can be initiated. These test can be very expensive. Mathematically modeling the system on personal computers can provide needed information prior to system tests, making the activation effort much more efficient.

### Methodology

The method by which to validate a math model includes an understanding of the components involved in modeling. The components in this case are the parts of the J6 Steam System (Fig. 2). From the steam generation plant, steam is stored in high pressure accumulators prior to testing. The six accumulators at J6 are typically filled with 775 psia saturated steam<sup>1</sup>. Steam

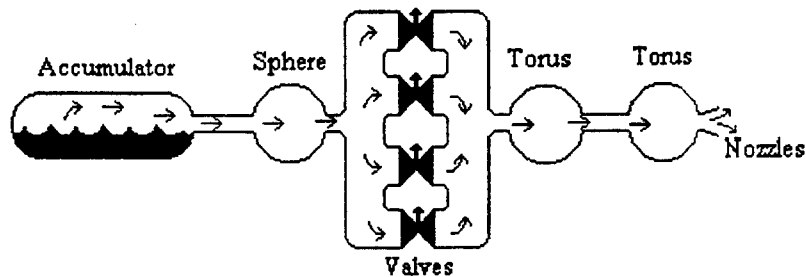

Figure 2. Model of J6 Steam System

flow is controlled by shut-off and pressure control valves. Shut-off valves are gate-style valves, traveling vertically. Pressure control valves are butterfly valves, controlled by hydraulic activators. There are four sets of control valves<sup>1</sup>. There are two toruses downstream of the control valves - an outer and inner torus which contains the steam ejectors. The valve controller is an automatic control which positions the valves in proper sequences.

A math model simulation is a set of equations which describe the system components. In the case of the J6 Steam System model, a FORTRAN code is used, and an input file is manipulated to control specifications during a model run.

Numbers entered into the input file include volumes of steam, number of accumulators, steam ejector area, initial accumulator pressure, and area of valve openings. These numbers are run through the code, and an output file is created as the simulation steps through small time increments. Included in the output are torus pressure, accumulator pressure, valve positions and nozzle flow. There are many other possible outputs, but for this project only the above are considered when validating the model.

### Analysis

By comparing the real data to the model data, significant differences in the two sets can be seen. During the April 23 run, sensors were utilized to help determine flows and pressures. Since the steam model is concerned with torus pressure, accumulator pressure, and valve positions, these results have been recorded from the test run (Fig. 3). Using the data given, one can find total steam mass used from the steam ejectors by converting torus pressure to mass flow and integrating the mass flow curve. This total mass from the steam ejectors can be compared to the total mass used out of the accumulators. The total mass used indicated by the torus pressure curve is 680 lbm.

Finding the mass of steam used from the accumulators can also be determined using a  $\Delta$  height to  $\Delta$  mass formula. During the April 1993 test run, the accumulators dropped 9.0 inches in water level (This does not include a short recharge before the final test). This drop indicates a release of 231K lbm.

Neither the 231K lbm from the accumulators nor the 372K lbm projected mass used are comparable to the 680 lbm from the steam ejectors (Fig. 4). This check reveals a mismatch between the actual data and the equations believed to describe the existing process. The math model is based upon the

same equations which provide the data mismatch. The model was employed to determine what changes to the system equations would correct the mismatch.

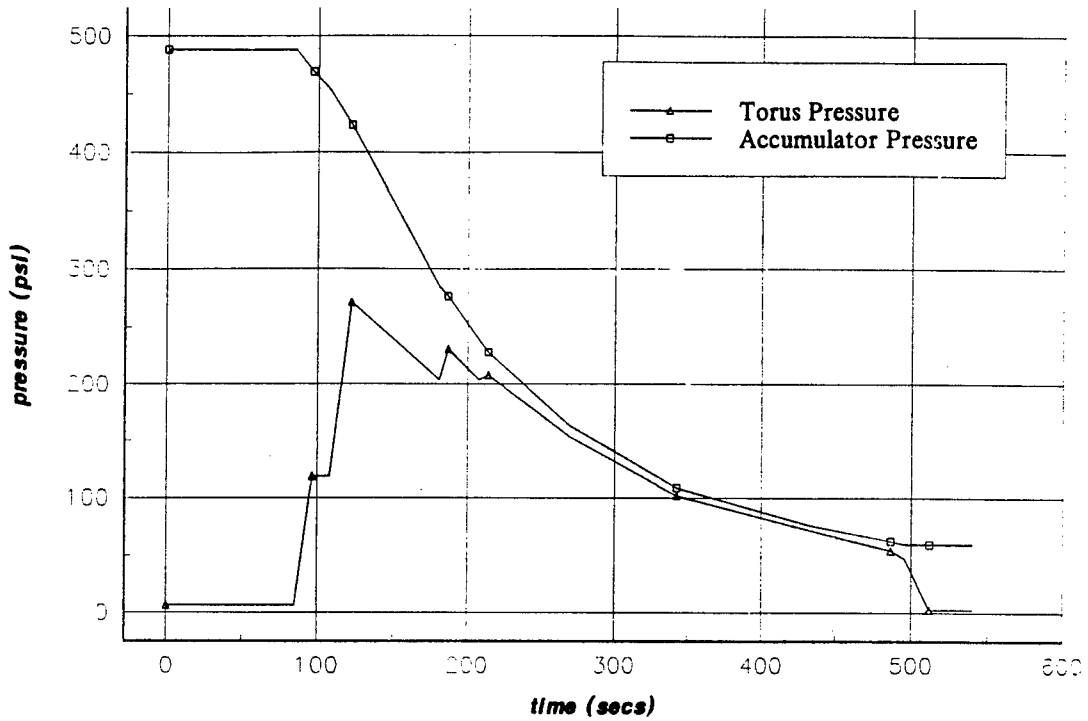

Figure 3. J6 Steam System Test - April 23, 1993

The following paragraphs include the results from four model tests performed. The first model is the "base line" model, or the model which includes component performances closest to the actual steam system. For the other three tests, performances are modified to create the most accurate output. These tests are performed to hypothetically determine which equations might be incorrect.

---

Pressure Drop	372K lbm
Δ height from the Accumulators	231K lbm
Total Mass Used from Ejectors	680K lbm

mass flow equation

$$\dot{m} = p_1 A \sqrt{\frac{\gamma g_c (\gamma + 1)^{\frac{\gamma}{1-\gamma}}}{RT_1}}$$

$$\gamma = 1.3 / R = 85.78 / g_c = 32.2 / A = 962.4$$

---

Figure 4. Results from J6 Steam System Test

**TEST ONE**

This test contains the information given by the mentor. This is referred to as the base line test. This four valve test opens the valves in step sequence. All performances are similar to those of the actual test. The result concerning accumulator pressure is accurate. The torus pressure prediction is lower than the actual data by a factor of 0.55. Graphically, the results are shown in Figures 5a-5b.

**TEST TWO**

In this test, the effective area of the steam ejector nozzle is reduced by a factor of 0.55. This is done in an attempt to increase the torus pressure. Graphs of the results are shown in Figures 6a-6b. Here, a single change produces a good match between actual and predicted data.

### **TEST THREE**

Test Three begins with base line conditions, but then the effective flow areas of the four steam valves are doubled by changing the flow coefficient from 0.3 to 0.6. All other conditions remain the same. The model responds appropriately by causing the accumulator pressure to drop rapidly, due to the larger opening of the valves. Torus pressure responds in a similar fashion. Due to the low accumulator pressure, the torus pressure rises to its peaks but falls too rapidly. Results are shown in Figures 7a-7b.

### **TEST FOUR**

In this final test, conditions are similar to Test Three, but the number of accumulators are increased to ten. This is done in an attempt to keep the pressures high while not decreasing nozzle flow. Accumulator pressure, torus pressure, and nozzle flow are all correct in comparison to the data. However, two changes to the baseline were required and obviously there are only six accumulators. Results from this test are shown in Figures 8a-8b.

### **SYSTEM UNDER AUTOMATIC CONTROL**

Using the same test procedures as shown above, a second set of tests are run using an automatic controller to open the valves to maintain the desired torus pressure profile. In these cases the user enter a torus pressure, unlike the first set of tests in which the valve positions are entered. The automatic controller reads the torus pressures and determines which and how much valves should be open. Since the data from the April steam run are questionable, a standard test procedure is used to obtain a model validation. All four tests show accurate response to the given setpoint torus pressure. All valves respond accordingly, and the system is able to provide stable pressure control throughout the profile.

### Accumulator Pressure

CF=0.3 Area=962 CFN=.98 (BL) Test One

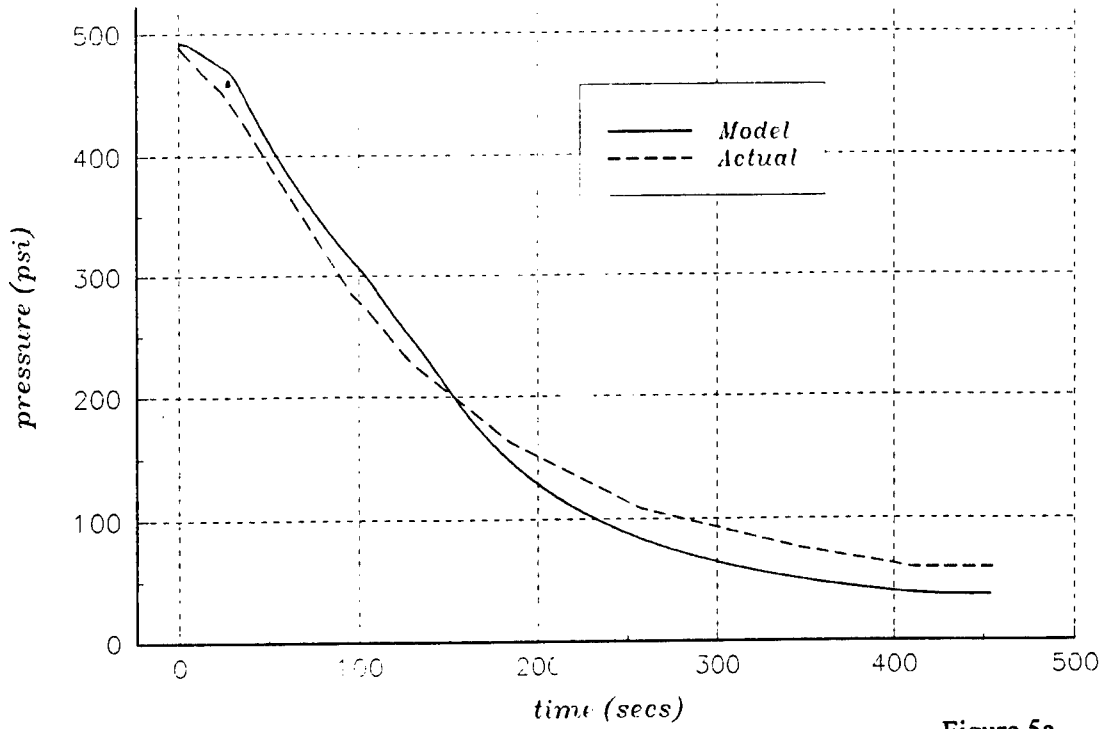

Figure 5a.

### Torus Pressure

CF=0.3 Area=962 CFN=.98 (BL) Test One

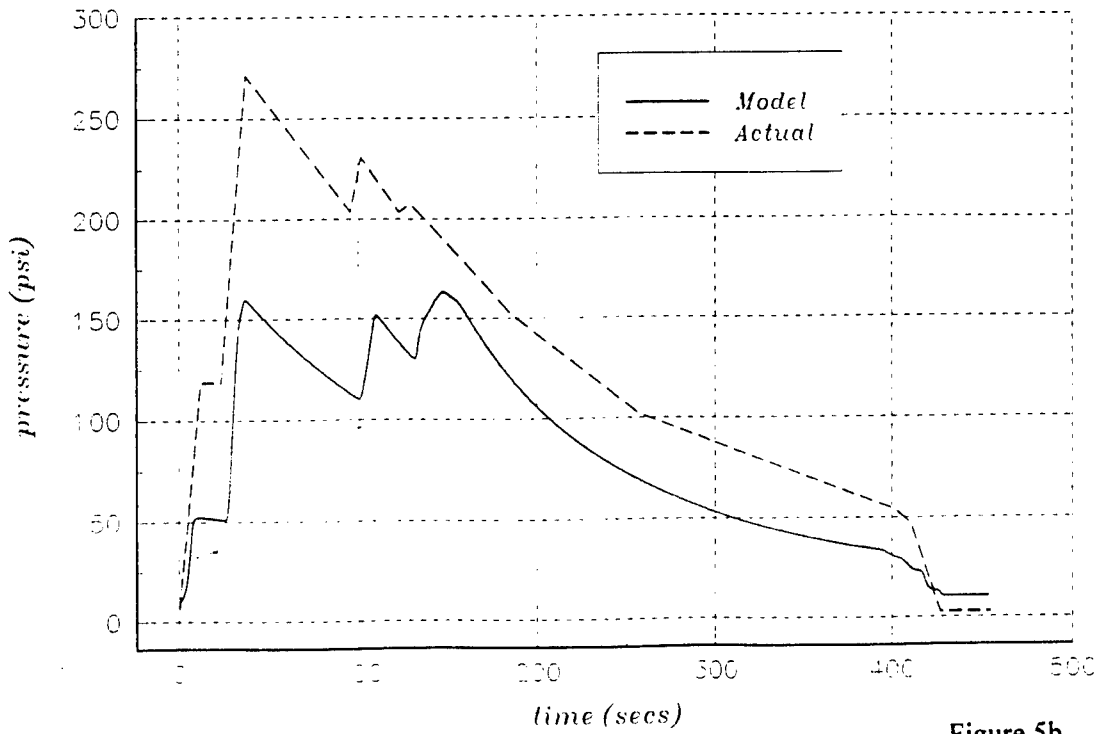

Figure 5b.

### Accumulator Pressure

VCF=0.3 Area=962 CFN=.55 Test Two

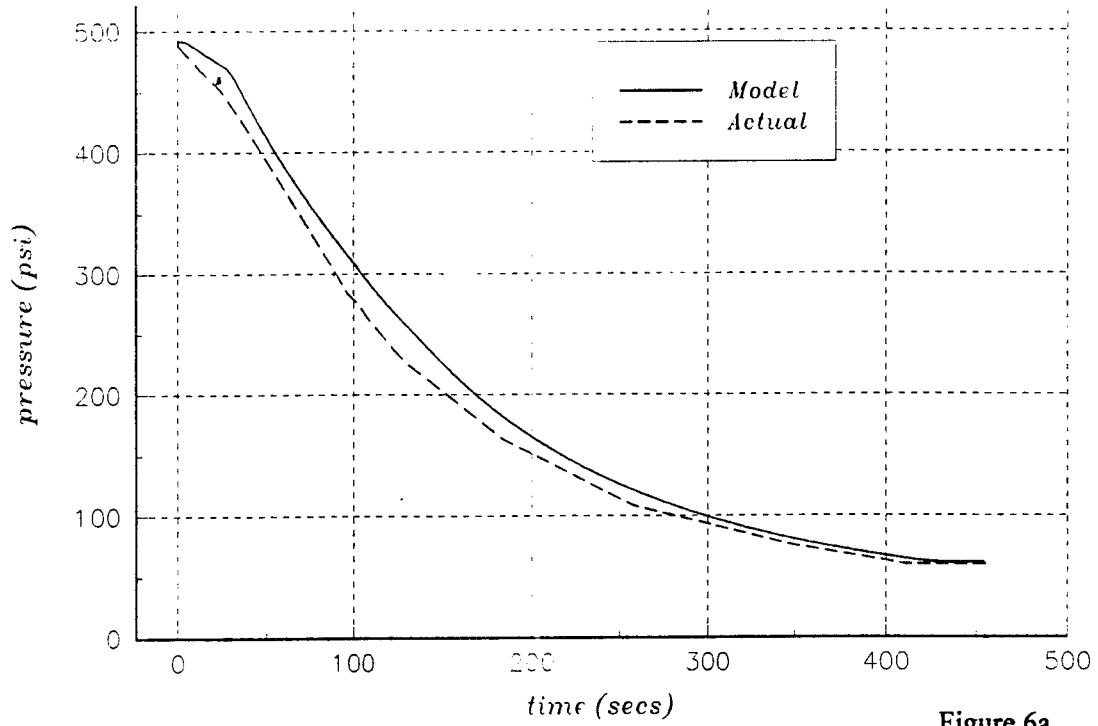

Figure 6a.

### Torus Pressure

VCF=0.3 Area=962 CFN=.55 Test Two

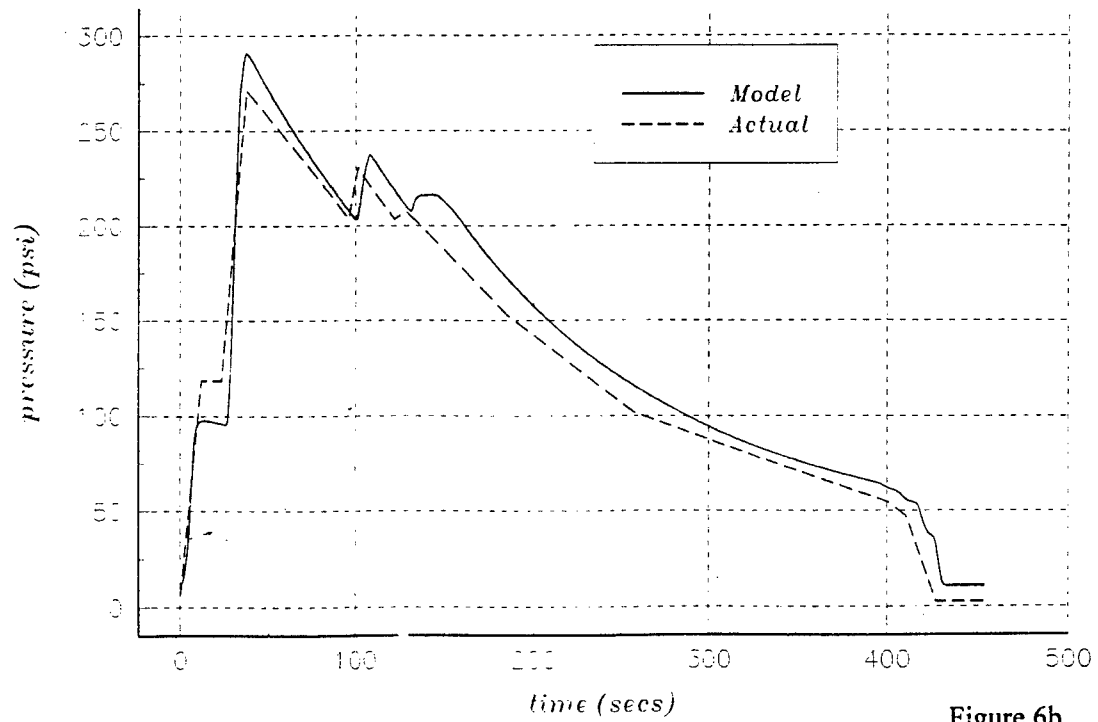

Figure 6b.

### Accumulator Pressure

VCF=0.6 Area=962 CFN=.98 Test Three

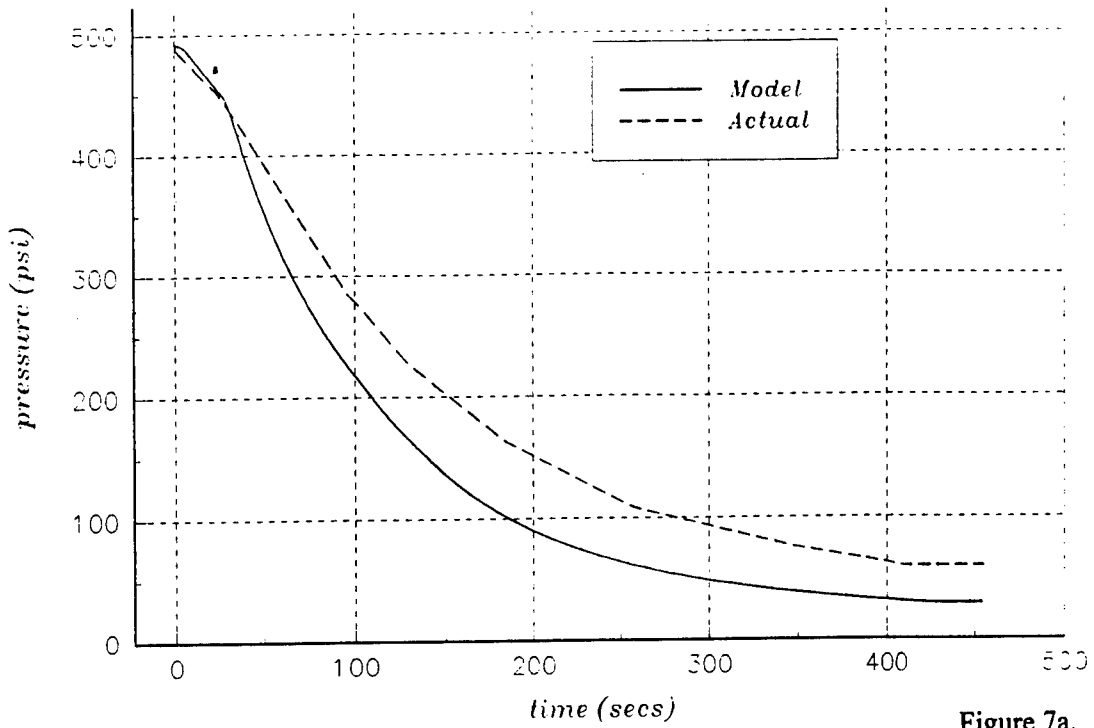

Figure 7a.

### Torus Pressure

VCF=0.6 Area=962 CFN=.98 Test Three

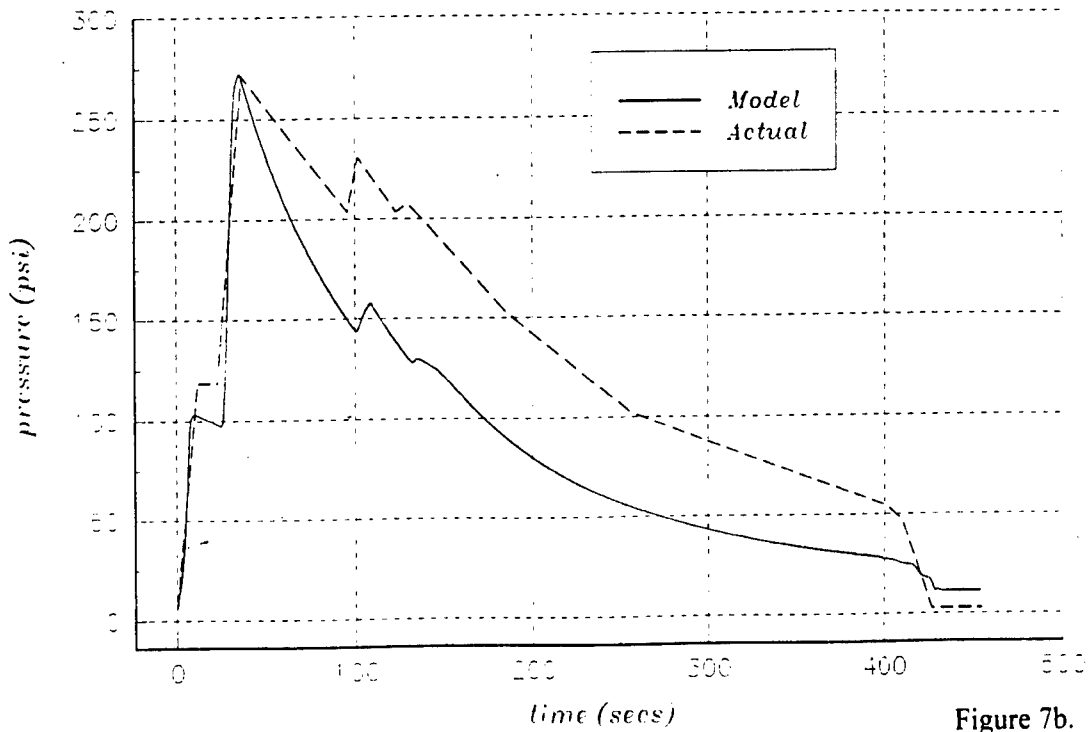

Figure 7b.

### Accumulator Pressure

VCF=3.6 Area=962 CFN=.98 Acc=10 Test Four

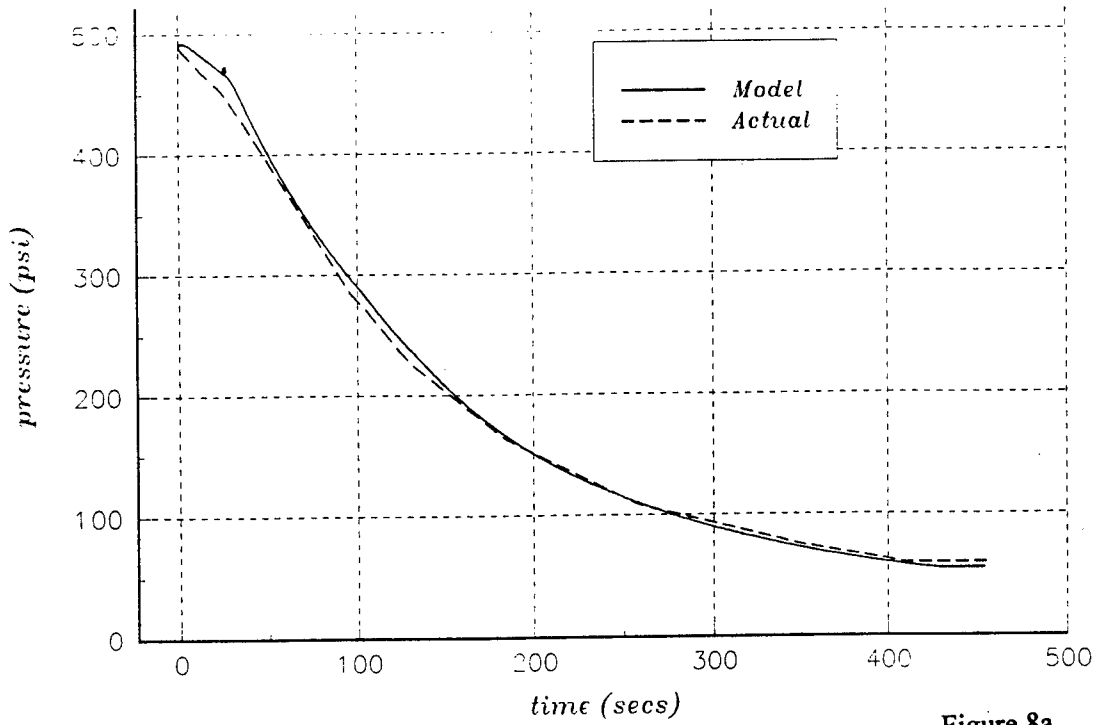

Figure 8a.

### Torus Pressure

VCF=0.6 Area=962 CFN=.98 Acc=10 Test Four

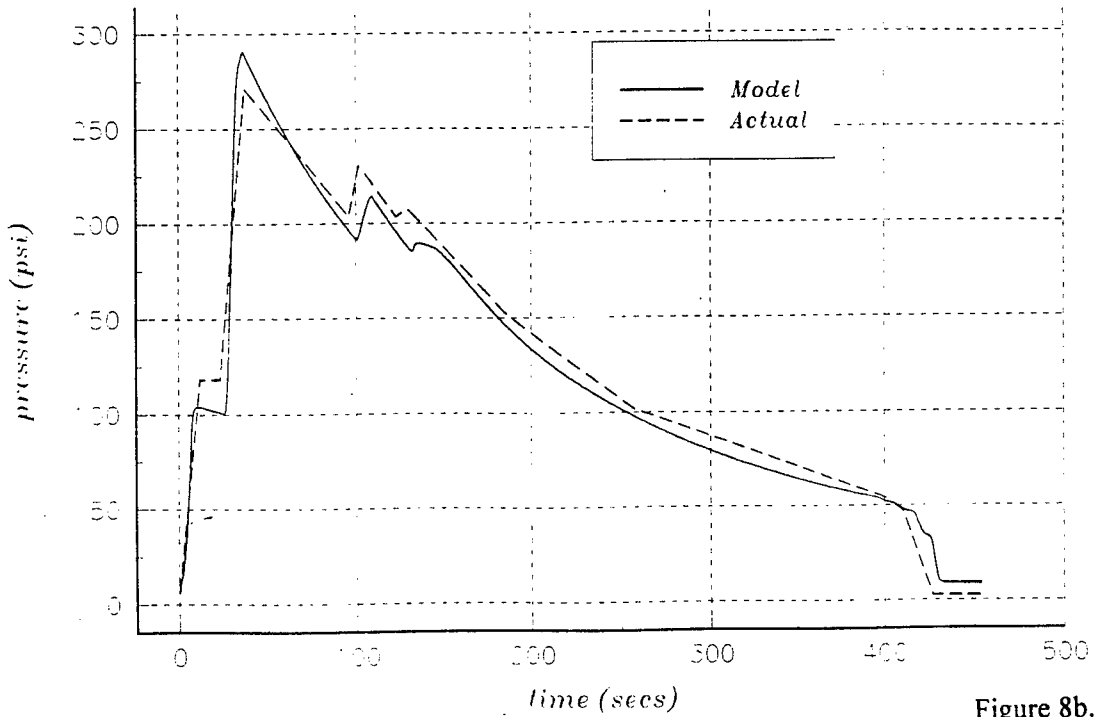

Figure 8b.

### Apparatus

A personal computer was the main apparatus used. The PC served two main purposes. The first was to run the steam system math model validation. The second was to record the output as plots using graphics software. A final presentation was given on August 6, 1993, and the PC was used to prepare the transparencies. Other devices used in calculations were a scientific calculator and an engineering scale. The engineering scale was used to transfer data from a graph into numbers to be entered into the input file used by the model. This device was also used in integrating the pressure curves.

### Conclusion

The four J6 model simulation test runs reveal a mismatch of data. One conclusion that could be made is that the data received from J6 is incorrect. Assuming that this is not true, one of the equations describing the system components must be in error. Of the four simulation tests performed, by decreasing the valve coefficient, a better result was obtained. Also, by increasing the amount of accumulators, a similar result also occurred. Due to the changes that were made, a conclusion can be drawn that if the April 23, 1993 data is correct, the four test runs show that by changing the coefficient of the formulas, better results were obtained. This result can be utilized to complete activation of J6 in the coming months.

**Bibliography**

**Project Book for PDC Number ANZY-970198: Large Rocket Test Facility (J6).**

Volume 1 of 2. Sections A-E. July 1986: Arnold Engineering  
Development Center.

**References**

**David E. Milleville**

Control Algorithm Development  
Analysis Engineering Branch of the Engineering Support Department  
AEDC Sverdrup Technology, Inc.

**L. Brent Bates**

Facility Analysis  
Analysis Engineering Branch of the ESD  
AEDC Sverdrup Technology, Inc.

**James D. Mitchell**

Flight Dynamics Flight  
Directorate of Technology  
Deputy for Operations  
Arnold Engineering Development Center (AFMC)

SGAP MODEL BUILDING

CHRIS MARLOW

TENNESSEE TECH. UNIVERSITY

FINAL REPORT FOR :  
AFOSR SUMMER RESEARCH PROGRAM

ARNOLD ENGINEERING DEVELOPMENT CENTER

CLARK LAWRENCE

CALSPAN  
AEDC

AUGUST 1993

## SGAP MODEL BUILDING

CHRIS MARLOW  
TENNESSEE TECH. UNIVERSITY  
AEDC

### ABSTRACT

The Grid Graphical Analysis Package (GridGAP) computer system was used to obtain computer visualizations of wind tunnel test collisions. The GridGAP software is a derivative of the Store-separation Graphical Analysis Package (SGAP) and both programs require the same model format. The GridGAP computer system displays animated three-dimensional projections on a workstation graphics monitor using store position and orientation data. The views can be translated, rotated, and scaled so that the operator can assume any desired vantage point from which to evaluate the store's movement. Wire-frame or panel computer models of the Captive Trajectory Support System (CTS) for the sixteen foot transonic wind tunnel which ranges from Mach 0.06 to Mach 1.6 were built. SGAP model building involves many steps. Locating dimensions for the part is the first necessary step to build a SGAP geometry model. Critical points must be located and coordinates for the points assigned. The point coordinate data is input into a data file, and an executable program is run which creates an output file in which the points are arranged in facets. With the facets a picture can be drawn and a verification of the dimensions and model accuracy can be made. Once SGAP files have been made for all the individual pieces, they can be put together in the correct configuration in accordance with the wind tunnel test installations. With the configuration files the GridGAP program can be run to show how the CTS, aircraft, and stores react with each other.

### ACKNOWLEDGMENTS

I would like to acknowledge the people who made my visit to Arnold Engineering and Development Center possible. I would like to thank Mr. Clark Lawrence for taking the time to teach me about computers and SGAP, and giving me a new outlook on the engineering field. I would also like to thank everyone in the Stores Integration Section for showing me what engineers really do. I would like to thank AEDC for giving me this opportunity. Finally I would like to give thanks to Research and Development Center for giving me the chance to spend the summer learning about engineering. I have enjoyed these eight weeks, and I feel that they will have an impact on my future career decisions.

## **SGAP Model Building**

Chris Marlow

### INTRODUCTION

The Grid Graphical Analysis Package, commonly called GridGAP, was used this summer to display visual geometry models of the Captive Trajectory Support System, often referred to as CTS, for the sixteen foot transonic wind tunnel which ranges from Mach 0.06 to Mach 1.6. The captive trajectory support is used for on-line trajectory analysis of air-launched stores. The CTS is commanded to drive the store model to a series of pre-selected positions relative to the aircraft. For trajectory calculations, the CTS becomes part of a store-separation simulator which uses the wind tunnel as a six-degree-of-freedom generator for the aerodynamic coefficients. A control system drives the CTS motors by either position commands or velocity commands in accordance with inputs from the computer.

The Grid Graphical Analysis Package computer system was used to obtain computer visualizations of wind tunnel test collisions. The GridGAP software is a derivative of the Store-separation Graphical Analysis Package (SGAP) and both programs require the same model format. The GridGAP computer system displays animated three-dimensional projections on a workstation monitor using store position and orientation data. The views can be translated, rotated, and scaled so that the operator can assume any desired vantage point from which to evaluate the store motion.

The process used to make the visual models involves several steps. Locating dimensions for the part is the first necessary step to build a SGAP geometry model. Critical points must be located and coordinates for the points assigned. The point coordinate data is input in a data file, and an executable program is run which creates an output file in which the points are arranged in facets. With the facets a picture can be drawn and a verification of the dimensions and model accuracy can be made. Once SGAP files have been made for all the individual pieces, they can be put together in the correct configuration in accordance with the wind tunnel test installations. With the configuration files the GridGAP program can be run to show how the CTS, aircraft, and stores react with each other. In summary SGAP is used to provide visual aid, so the user can see how the CTS, aircraft, and store models will move with respect to each other.

### METHODOLOGY

The GridGAP computer system displays animated three-dimensional projections on a workstation monitor using store position and orientation data. The views can be translated, rotated to different views, and scaled to enlarge or reduce the size of the picture so that the operator can assume any desired vantage point from which to evaluate the store motion. Also a printout of the part can be obtained. Some of the pieces modeled with the SGAP are the pitch and yaw housing of the CTS; air launched cruise missile (ALCM) model support strut, adapter, and dummy balance; and various support sting components.

One method of graphically simulating wind tunnel tests on the computer is by using the SGAP software. The SGAP software is run on the Apollo computer workstation. Many steps are involved in making a computer generated visual model. First critical points must be assigned along the part for all corners, curves, and surfaces. The number of critical points will vary depending on how complex and detailed the

part is. Once enough critical points have been assigned to define the surfaces of the part, coordinates must be obtained for these points. These X,Y,Z coordinates can be found by studying extensive drawings, dimensions, and by calculating distances with basic trigonometry functions. The drawings used to find these dimensions are the model assembly drawings and usually lack necessary dimensions needed to build a SGAP geometry model. Sometimes even the actual wind tunnel model must be measured to obtain certain dimensions which are not on the drawings. The points are connected in some logical sequence by a series of straight-line segments to form polygons, referred to as facets, which approximate the surfaces of the geometry. These facets make up the external surfaces of the part which is being modeled. So in a complex part where curves, radiuses, and complex surfaces and angles are to be modeled, many facets would be required to show them. The X,Y,Z coordinates and orders to connect the points are put in a data file, shown in figure 1. An executable program is run to create an output file which contains the data points arranged into facets. A facet file is shown in figure 2, which contains the coordinates of each individual facet.

After geometry files have been built for each individual piece they can be put together in a configuration file. A configuration file is an assembly of specific geometry files, or models, just as a configuration in a wind tunnel test is an assembly of specific model components. The analogy is direct. A configuration file consists of the information needed to locate all geometry files on the screen in the correct three-dimensional relationship. A configuration file format is shown in figure 3. Origin points are referenced to other axis systems so the models will fit together with respect to each other. After the CTS, containing balance, stings, mechanisms and boom, was assembled it had to be put in the correct position with respect to the F-18 aircraft and adapters in a computer simulated version of the test section. The first step in assembling the test section was to position the ALCM strut and aircraft support adapters with respect to the tunnel floor. After the strut and adapters were in the correct spot the aircraft could be positioned on the strut. Finally the CTS and store could be put in the correct location with the aircraft. Configuration files had to be assembled for the different configurations used in the tunnel. Configurations also had to be obtained for each store and each store location. I was able to assemble configurations for the five different stores on each store position and with two different sting assembly versions. These configurations can then be put in the GridGap program which will simulate the relative movements of the store and CTS mechanism. The GridGAP program can provide the user with a visualization of how the CTS and store are going to move with respect to each other, thus allowing the user to detect any points where the store or CTS may come in contact with the aircraft or the aircraft support system. Having gone through this process will save time and money when the actual testing begins in the tunnel.

## RESULTS

With the SGAP software, all the models needed to represent the different F-18 configurations were constructed. Some of the pieces I modeled were the pitch and yaw housing, ALCM strut, adapter, balance and various sting components, shown in figures 4 - 12. The GridGAP program was used with the different configuration files to detect possible contact points. In summary, at the time of my departure SGAP geometry files had been built for the CTS and aircraft support adapters and configuration files also existed which contained the different stores in each of the different locations.

## OBSERVATIONS

The High School Apprenticeship Program gave me the chance to observe the engineering field with a different light. I learned a great deal about computers, airplanes, stores, and wind tunnel testing. Also I was able to see 16T, a sixteen foot transonic wind tunnel which ranges from Mach .06 to 1.6. While in the wind tunnel I had the opportunity to interact with the project engineer. In the wind tunnel different flight conditions can be obtained. Pressures, temperatures, Mach numbers, roll, pitch, and yaw angles can all be varied according to actual flight conditions. Being able to see the wind tunnel was a great and fascinating experience. The experience I received this summer at AEDC is unmeasurable and can not be taught in school or read in books.

## REFERENCES

1. Dix,R.E. "Description And Operation Of A Computer Graphics System For Qualitative Analysis Of Store-separation Trajectories." AEDC-TMR-5-P10, July 1985.
2. Rogers,J.C. "An Overview Of Wind Tunnel Test Techniques Used To Investigate CBU-89/B Separations From An F-111E Aircraft And Comparison With Flight Test Results." AEDC-TMR-93-P3, February 1993.
3. AEDC, "Test Facilities Hand Book." March 1984.
4. Keen,K.S. and Clippard,R.L. "Procedures For The Preparation Of Computer-Graphic Models For Separation Trajectory Analyses", AEDC-TR-88-39, February 1989.

```

12
1.15    7   -5.4
3.435   7   -7
3.435   8.6 -7
24.35   7   -7
24.35   15  -7
13.55   15  -7
24.35   15   7
13.55   15   7
3.435   8.6  7
3.435   7    7
1.15    7    5.4
24.35   7    7
8
3  1,  3,  2
3  9, 11, 10
5  2,  3,  6,  5,  4
5  7,  8,  9, 10, 12
6  8,  6,  3,  1, 11, 9
4  8,  7,  5,  6
4  5,  7, 12,  4
6 12, 10, 11,  1,  2,  4

```

figure 1. data file



```

MODEL 1 REF 0 COLOR 0 ACT T COL N
16t.10
O 0.000000 0.000000 0.000000
A 1.000000 0.000000 0.000000
MODEL 2 REF 1 COLOR 135 ACT A COL Y 0.000000 1.000000 0.000000
pittab.strut.10
O 2400.000000 0.000000 -1900.000000
A 2401.000000 0.000000 -1900.000000 2400.000000 1.000000 -1900.000000
MODEL 3 REF 2 COLOR 135 ACT A COL Y
/USER/LAWRENCE/F18.DIR/F18RAF
O -1330.000000 0.000000 865.0000000
A -1329.000000 0.000000 865.1390000 -1330.00000 -1.0000000 865.0000000
MODEL 4 REF 2 COLOR 165 ACT A COL Y
/USER/LAWRENCE/F18.DIR/F18RFF
O -1330.000000 0.000000 865.0000000
A -1329.000000 0.000000 865.1390000 -1330.00000 -1.0000000 865.0000000
MODEL 5 REF 2 COLOR 210 ACT A COL Y
/USER/LAWRENCE/F18.DIR/F18RCANP
O -1330.000000 0.000000 865.0000000
A -1329.000000 0.000000 865.1390000 -1330.00000 -1.0000000 865.0000000
MODEL 6 REF 2 COLOR 240 ACT A COL Y
/USER/LAWRENCE/F18.DIR/F18RHORZ
O -1330.000000 0.000000 865.0000000
A -1329.000000 0.000000 865.1390000 -1330.00000 -1.0000000 865.0000000
MODEL 7 REF 2 COLOR 240 ACT A COL Y
/USER/LAWRENCE/F18.DIR/F18RUW
O -1330.000000 0.000000 865.0000000
A -1329.000000 0.000000 865.1390000 -1330.00000 -1.0000000 865.0000000
MODEL 8 REF 2 COLOR 240 ACT A COL Y
/USER/LAWRENCE/F18.DIR/F18RLW
O -1330.000000 0.000000 865.0000000
A -1329.000000 0.000000 865.1390000 -1330.00000 -1.0000000 865.0000000
MODEL 9 REF 2 COLOR 270 ACT A COL Y
/USER/LAWRENCE/F18.DIR/F18RVERT
O -1330.000000 0.000000 865.0000000
A -1329.000000 0.000000 865.1390000 -1330.00000 -1.0000000 865.0000000
MODEL 10 REF 2 COLOR 135 ACT A COL Y
/USER/LAWRENCE/F18.DIR/F18RMF
O -1330.000000 0.000000 865.0000000
A -1329.000000 0.000000 865.1390000 -1330.00000 -1.0000000 865.0000000
END OF FILE
END OF DATA

```

FIGURE 3. CONFIGURATION FILE

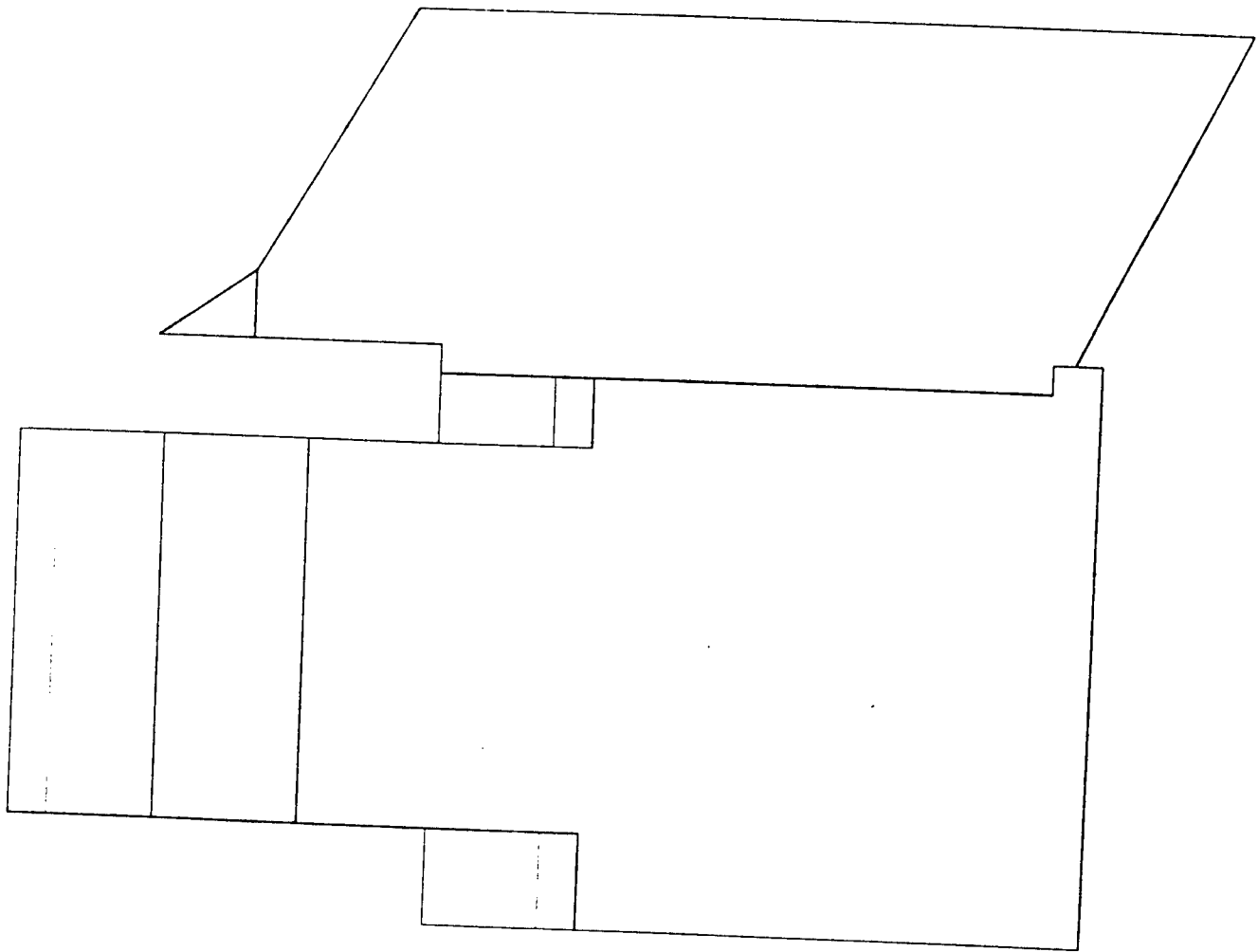

**FIGURE 4. YAW HOUSING, SIDE VIEW**

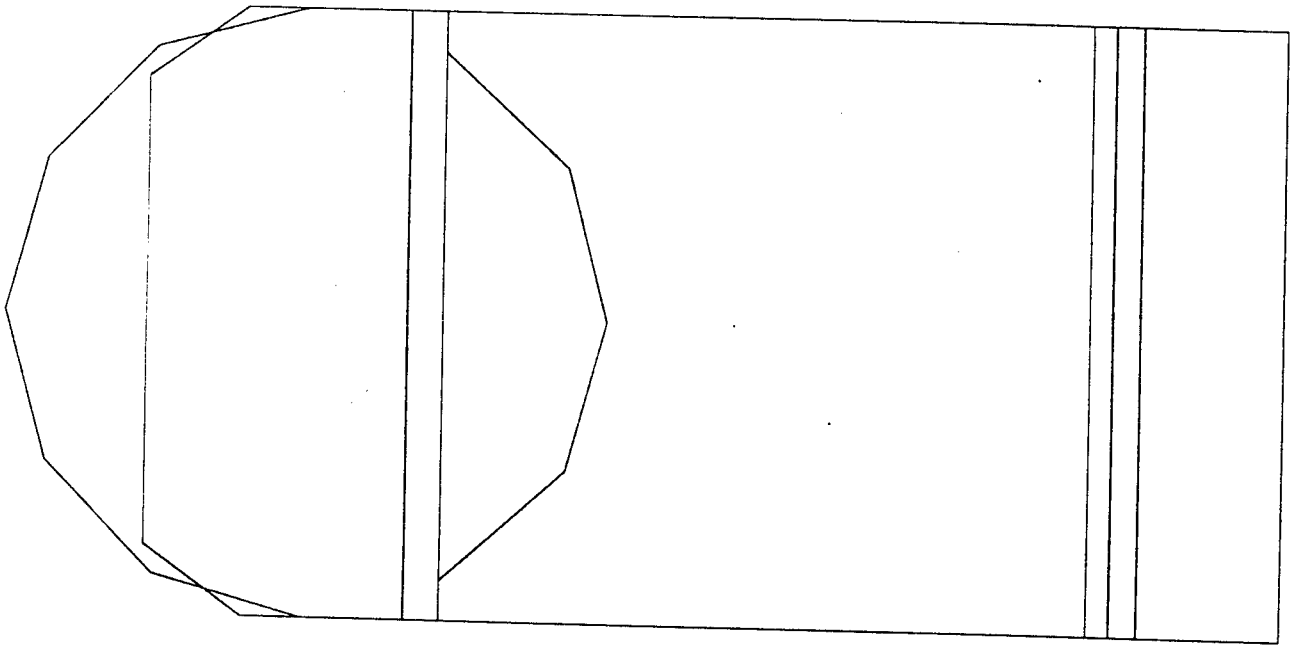

**FIGURE 5. YAW HOUSING, TOP VIEW**

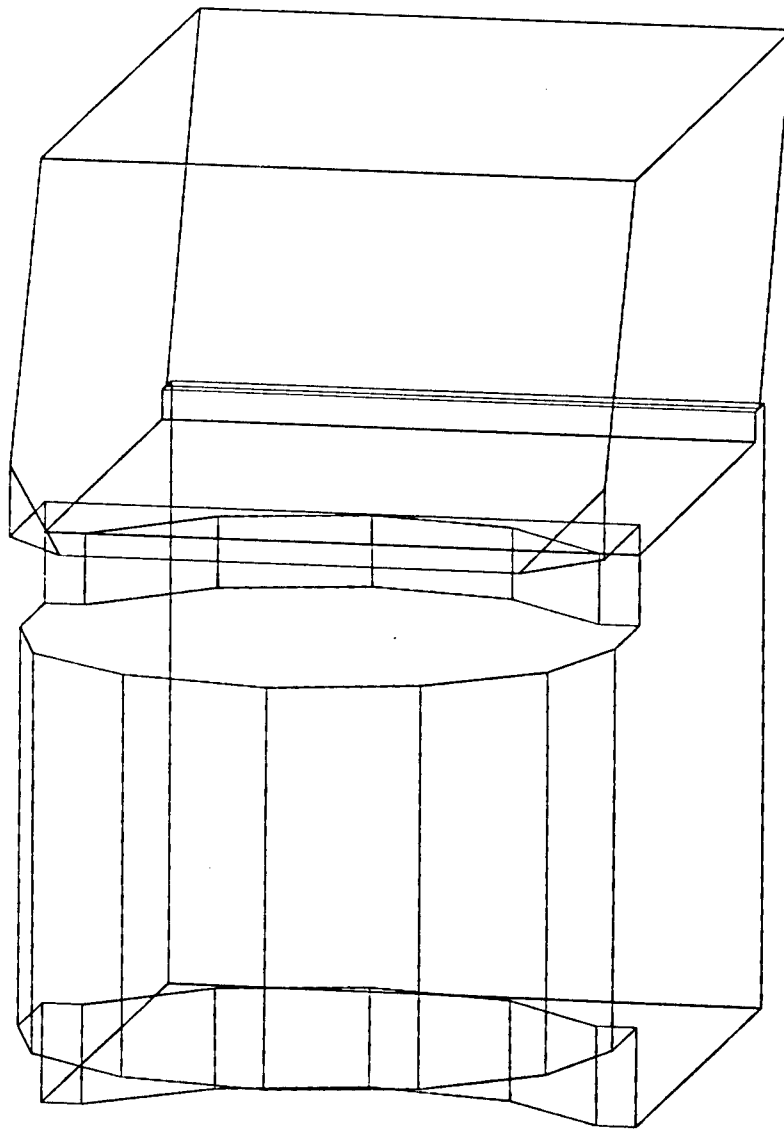

**FIGURE 6. YAW HOUSING, ISOMETRIC VIEW**

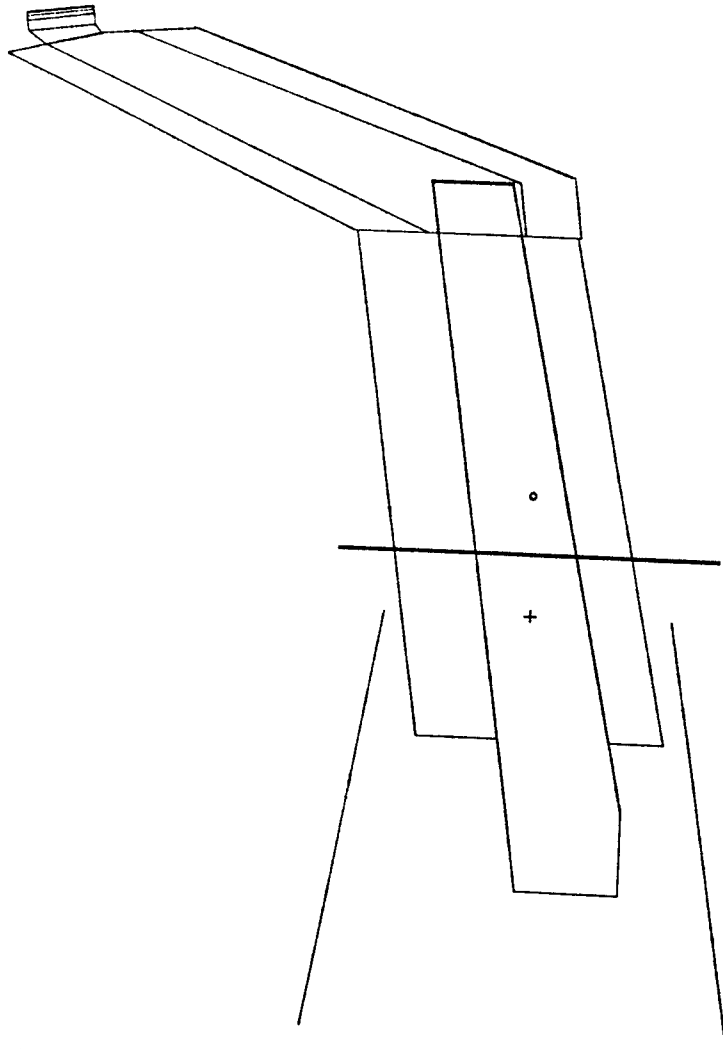

**FIGURE 7. ALCM STRUT, PITCH TABLE, SUPPORT STRUT, AND BALANCE  
SIDE VIEW**

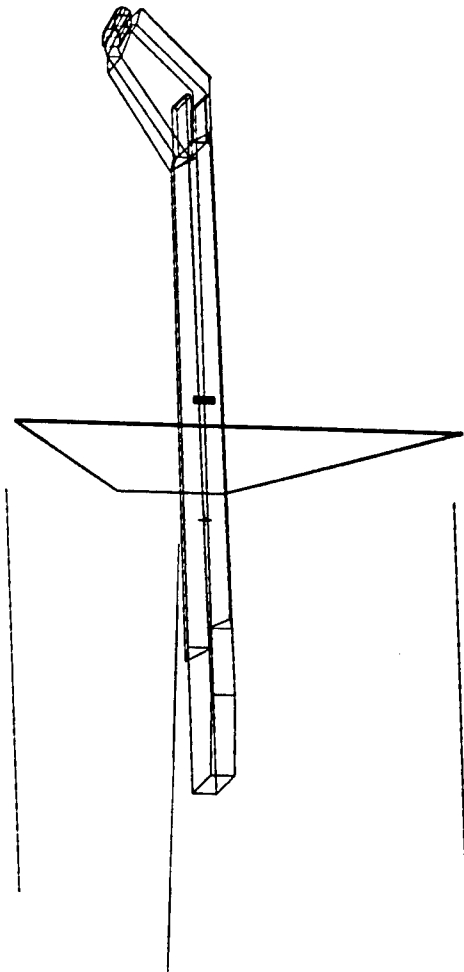

**FIGURE 8. ALCM STRUT, PITCH TABLE, SUPPORT STRUT, AND BALANCE  
ISOMETRIC VIEW**

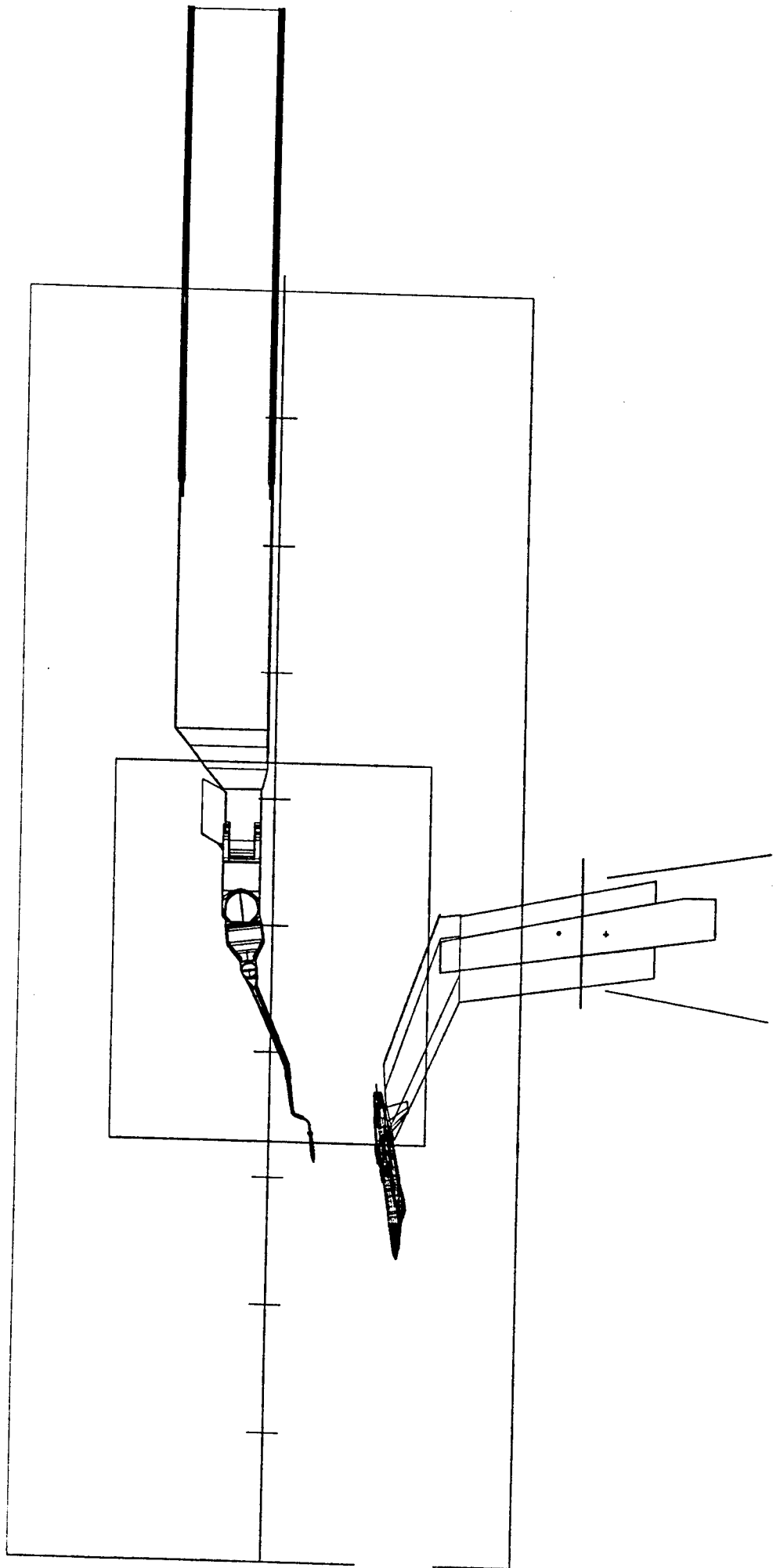
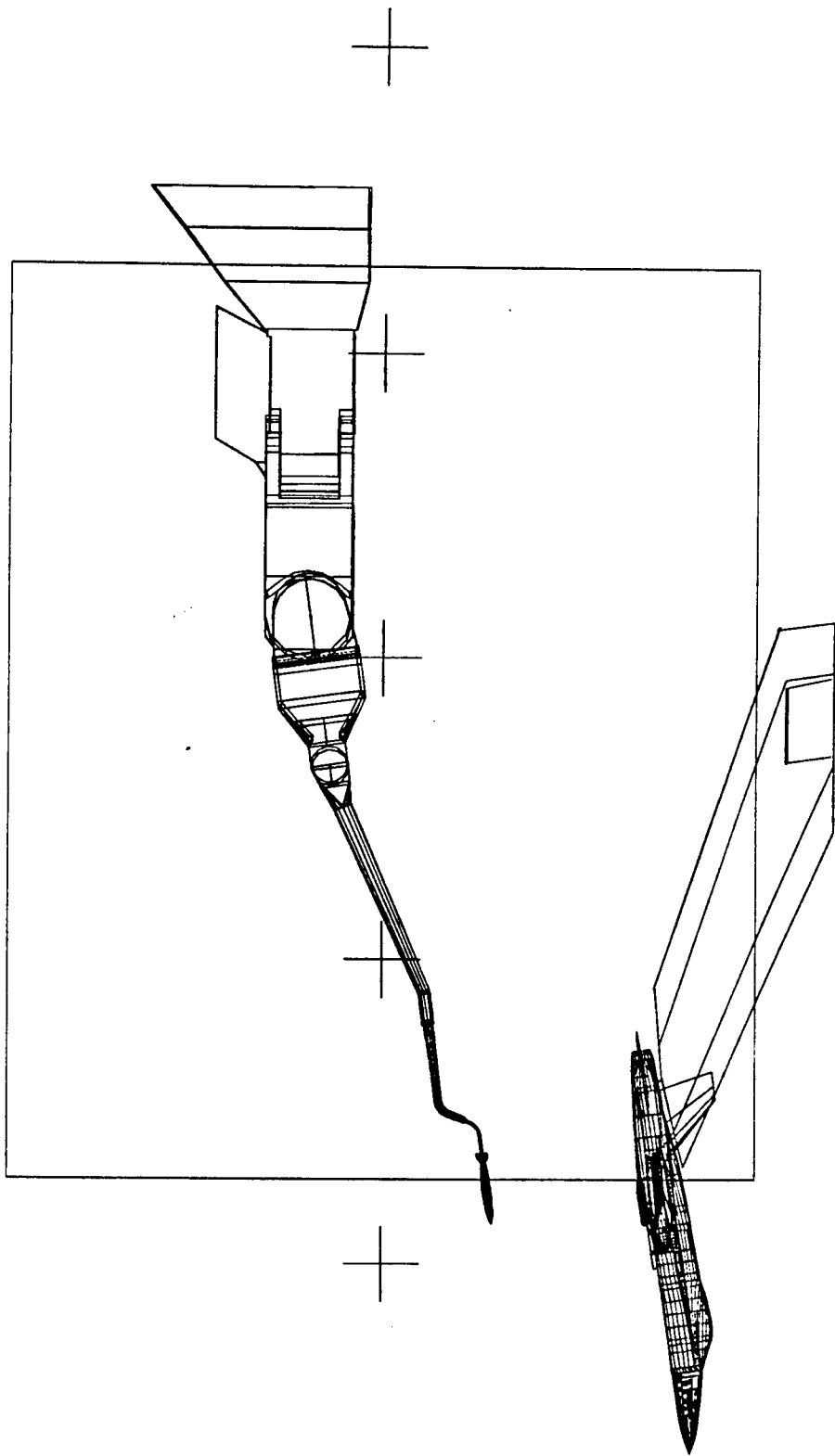

FIGURE 9. F-18 AIRCRAFT, SUPPORT STRUCTURES, AND CTS  
SIDE VIEW



**FIGURE 10. F-18 AIRCRAFT, SUPPORT STRUCTURES, AND CTS  
MAGNIFIED SIDE VIEW**

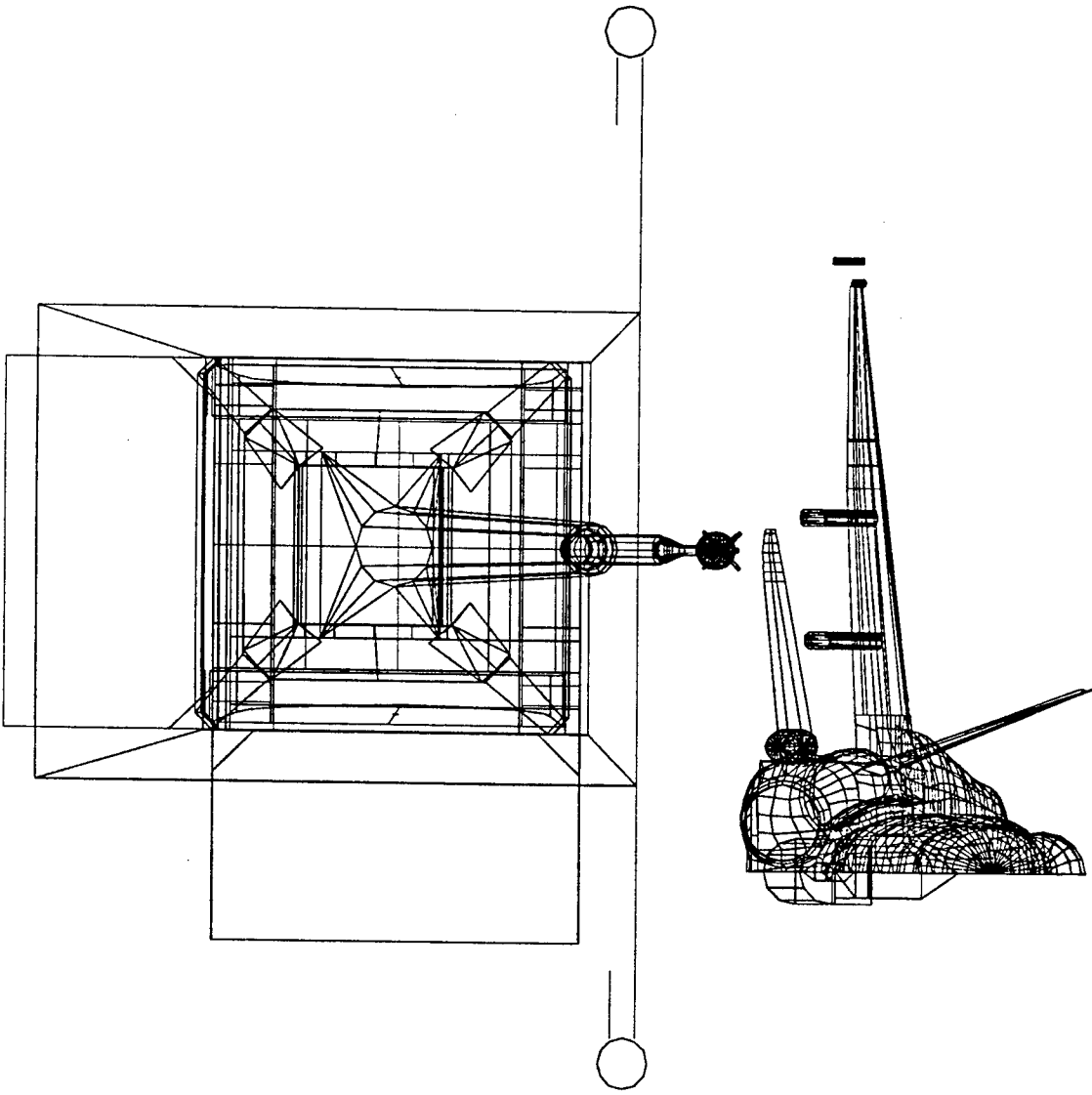

FIGURE 11. F-18 AIRCRAFT,SUPPORT STRUCTURES, AND CTS  
FRONT VIEW

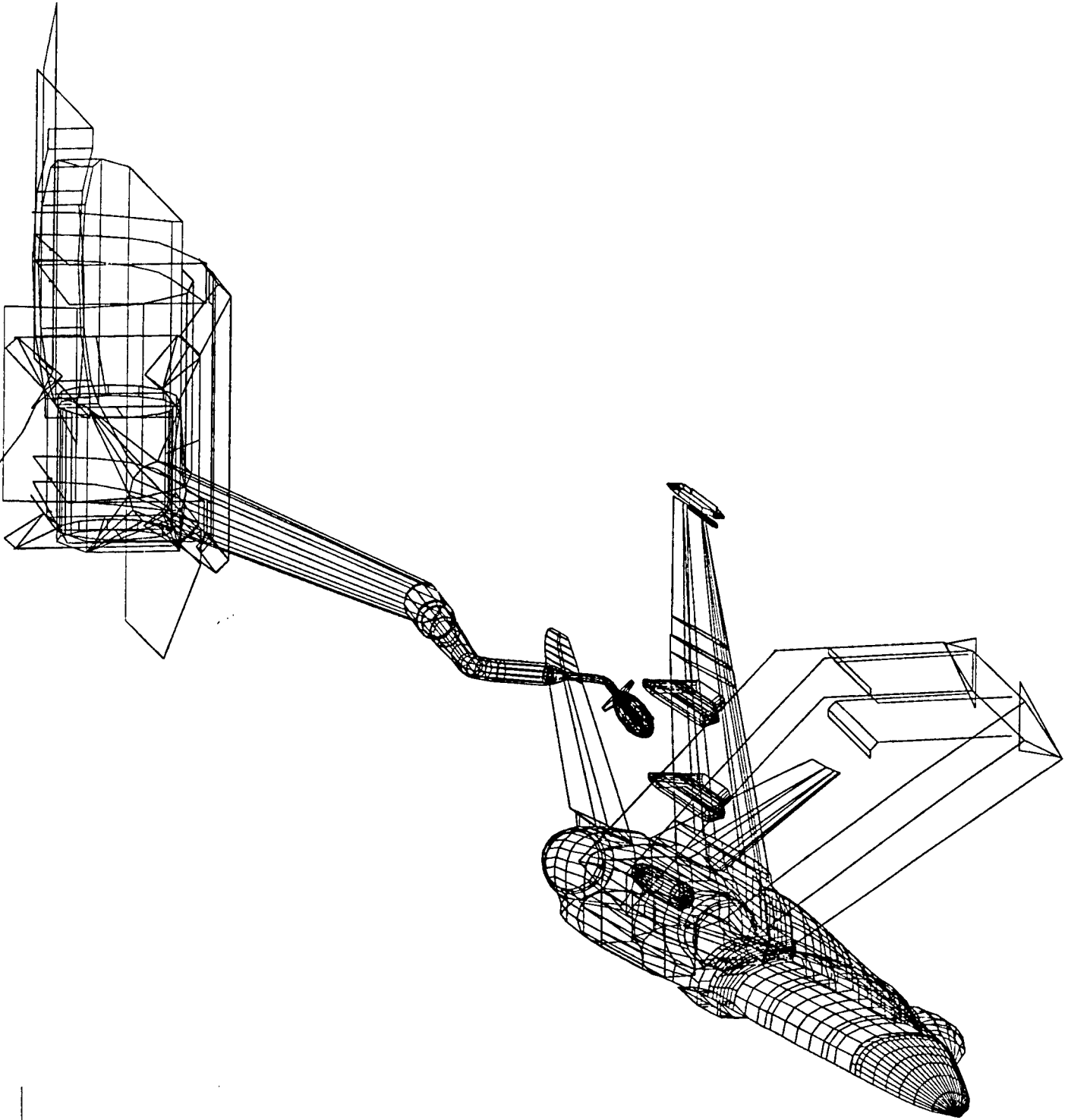

FIGURE 12. F-18 AIRCRAFT, SUPPORT STRUCTURES, AND CTS  
ISOMETRIC VIEW

BALANCE CHECKOUT PROCEDURE PROGRAM

FOR PITCH, ROLL, AND YAW

Gilbert G. Morton

Tennessee Technological University

Wayne Hawkins

Calspan

Final Report for:

AFOSR Summer Research Program

Arnold Engineering Development Center

Sponsored by:

Air Force Office of Scientific Research

Arnold Air Force Base, Tullahoma, TN

August 1993

BALANCE CHECKOUT PROCEDURE PROGRAM  
FOR PITCH, ROLL, AND YAW

Gilbert G. Morton

Tennessee Technological University

Abstract

The balance checkout process is a very complex procedure that involves many calculations. My project was to design a program to cut down on the number of manual calculations in order to get a quicker analysis of the situation. By inputting a few numbers in a spreadsheet, the required parameters will be calculated in much less time.

## BALANCE CHECKOUT PROCEDURE PROGRAM

### FOR PITCH, ROLL, AND YAW

Gilbert G. Morton

Force and moment measurements are made with strain-gauge balances mounted inside the test model. These six component balances measures force and moments in the pitch and yaw planes, rolling moment, and axial force. In recent years the balance checkout process has gotten easier with the advance of computers, but it is still a very complex process. The balance checkout procedure, a process of hanging weights on the balance at different stations, is used to calibrate the strain gauges so that they will read correctly during the test. The moments that are calculated are compared with the balance specifications to see if the balance needs to be adjusted.

This process of hanging weights on the balance and calculating moments should be done at least two shifts prior to testing the model. Typically, a calibration sleeve with equally spaced attachment threads is connected to the balance. A loading platform is connected to the sleeve via flexure support that concentrates the load as if it were a point load acting on the sleeve. Incrementally, loads are applied to the loading platform, each time releveling the sting balance combination and recording psi, theta, and phi changes and strain gauge component voltage outputs caused by the incremental load. This procedure is repeated at several x-stations and correlation of voltage output versus applied load and load station are computed to determine the balance's calibration coefficients. The angle changes (psi, theta, phi) are also used to determine the correct sting bending relation. The balance planned for use in this test installation is a moment type which

use the combination of a forward and aft half bridge circuit strain gauge pair to measure normal and side force loading.

The calibration procedures will include first and second order balance interaction terms to compensate for gauge misalignments, machining tolerance limitations, material impurities, and output non-uniformity. Essentially, an interaction term accounts for voltage changes on one component of the balance caused by an applied load on another balance component. Often the relationship between the gauges are nonlinear and require second order corrections to be made to provide the highest resolution possible.

The program is designed to run in Microsoft Excel. By inputting the station values for  $X_1$ ,  $X_2$ , XMRP, and the weights that are going to be hung at each station, then the program will calculate the moments for each load. XMRP is defined as the middle reference point of the balance after it is installed on the sting.  $X_1$  is a point of reference determined by the project engineer where the moments are calculated from.  $X_2$  is the difference between  $X_1$  and XMRP. This program will calculate the moments from  $X_1$  and XMRP. It is possible to translate  $X_1$  away from XMRP, but then the moments are not as accurate. The closer  $X_1$  is to XMRP, the more accurate the moment calculations will be.

This project has taught me that many things have to be done before a wind tunnel test can begin. I was amazed at what all has to be done. This project has also familiarized myself with many commercial software packages. I have had smaller projects to do in which I have used Microsoft Excel, Word, and Power Point.

BALANCE CHECKOUT PROCEDURE FOR ROLL

WRAP LACING CORD AROUND BODY NEAR BALANCE  
ADAPTOR AND TIE ON SMALL LOAD PAN

approximate X1 = 25.18 Xt= 0.654  
XMRP= 24.526

POINT	LOAD	APPLIED @ BAL			MOMENT AT XMRP (in-lbs)
	Y (in)	ROLL (deg)	FN (lbs)	MOMENT (in-lbs)	
1	0.0000	-150	0	0.00	0
2	1.0000	-120	-1.25	-30.23	-29.4075
3	2.0000	-90	-2.5	-57.95	-56.315
4	3.0000	-60	-3.75	-83.18	-80.7225
5	4.0000	-30	-5	-105.90	-102.63
6	5.0000	0	-6.25	-126.13	-122.0375
7	4.0000	30	-7.5	-158.85	-153.945
8	3.0000	60	-8.75	-194.08	-188.3525
9	2.0000	90	-10	-231.80	-225.26
10	1.0000	120	-11.25	-272.03	-264.6675
11	0.0000	150	-12.5	-314.75	-306.575

**INFRARED BORESCOPE EVALUATION**

**CHRIS NORTHCUTT  
GRADUATE of FRANKLIN COUNTY HIGH SCHOOL  
TENNESSEE TECHNOLOGICAL UNIVERSITY**

**FINAL REPORT for:  
AFOSR SUMMER RESEARCH PROGRAM  
ARNOLD ENGINEERING DEVELOPMENT CENTER**

**SPONSORED by:  
AIR FORCE OFFICE of SCIENTIFIC RESEARCH  
BOLLING AIR FORCE BASE, WASHINGTON, D.C.**

**AUGUST 1993**

## **INFRARED BORESCOPE EVALUATION**

**CHRIS NORTHCUTT**

**GRADUATE of FRANKLIN COUNTY HIGH SCHOOL**

**TENNESSEE TECHNOLOGICAL UNIVERSITY**

### **ABSTRACT**

The usefulness of an infrared borescope was evaluated through a series of laboratory tests. Tests were performed to measure the emissions from small scale heat sources. A two diameter blackbody set at a temperature of 200°C was scanned by the infrared borescope, and the data taken was digitized and converted into an image on a personal computer. The images provided a view of the blackbody with different colors indicating the varying heat emissions.

## **INFRARED BORESCOPE EVALUATION**

**CHRIS NORTHCUTT**

### **INTRODUCTION**

An infrared measurement of the heat from a very hot engine surface is a common method used to estimate surface temperature. This technique is limited when the emissive characteristics of the surface are not well-known. The measurement may also be greatly affected by radiation coming from another hot object nearby and being reflected from the surface in question because a single measurement does not differentiate between self-emitted radiation and reflected radiation. Despite these difficulties, infrared imaging is widely used and allows thermal mapping of a surface, sometimes allowing one to see absolute temperatures.

### **ACKNOWLEDGEMENTS**

The author would like to thank Mr. Ben Hartsfield for his time in the design of the infrared borescope and in teaching some of the basic principles of infrared imaging. Also, the author would like to thank the EL3 personnel for all the suggestions and guidance to make this apprenticeship program a successful learning experience about a future career in engineering.

## DESCRIPTION

The concept of the scanning infrared borescope in Figure 1 is as follows: A 10 millimeter diameter sapphire lens images a point on the scanned nozzle surface. An electric motor turning at 1725 rpm rotated the probe at 862 rpm through a two-to-one timing belt drive. A two-lobed chopper mounted on the motor shaft chopped the detector view of the fiber at four times per probe revolution. The aft end of the fiber was imaged onto a liquid nitrogen cooled indium antimonide detector with a one inch focal length calcium fluoride lens. The rotating probe assembly was mounted on a mechanical traverse table capable of traversing 3.0 inches per second in the axial direction.

A two inch diameter blackbody set at a temperature of 200°C was placed at a distance of 11.5 inches from the centerline of the probe. The probe was scanned past the blackbody, and data was recorded on a PC. A high emissivity shield was then installed at the aft end of the probe and a heater was installed under the aft probe bearing and data scans were recorded with and without bearing heat addition.

## RESULTS

A scan of the blackbody was made with no bearing heat and with the aft bearing heated to 150° Fahrenheit. The detector signals with and without are presented in Figures 2 and 3, respectively. Note the scale change. The waveform generated by the difference in emitted energy from the ferrule and the chopper is seen to be much larger with the bearing heat on (see Figure 3). It would swamp the signal produced by the blackbody.

## **SUMMARY**

The results of the tests performed with the infrared borescope have indicated that major changes in design and function are needed for the borescope to rightfully perform its tasks. These changes are now being made to decrease the sensitivity to the heating of internal components of the borescope. To be a success, the borescope must be able to withstand extreme temperatures involved in testing and varying temperatures also. Output that is affected by temperature change would not be in any way helpful to the engineers.

## **OBSERVATIONS**

Through working in the lab with the infrared borescope, the author was able to learn the intended functions of the borescope and the basic ideas behind infrared imaging, and gain a better insight into computer systems and mechanical and electrical engineering professions.

The author considers the High School Apprenticeship Program to be a success in the field of engineering and an excellent learning experience for any teenager who expresses an interest in a technical field.

## BIBLIOGRAPHY

1. The Infrared Handbook. Colorado: Research Systems, Inc., 1991.
2. Szymanski, Herman. Theory and Practice of Infrared Spectroscopy. New York: Plenum Press, 1964.

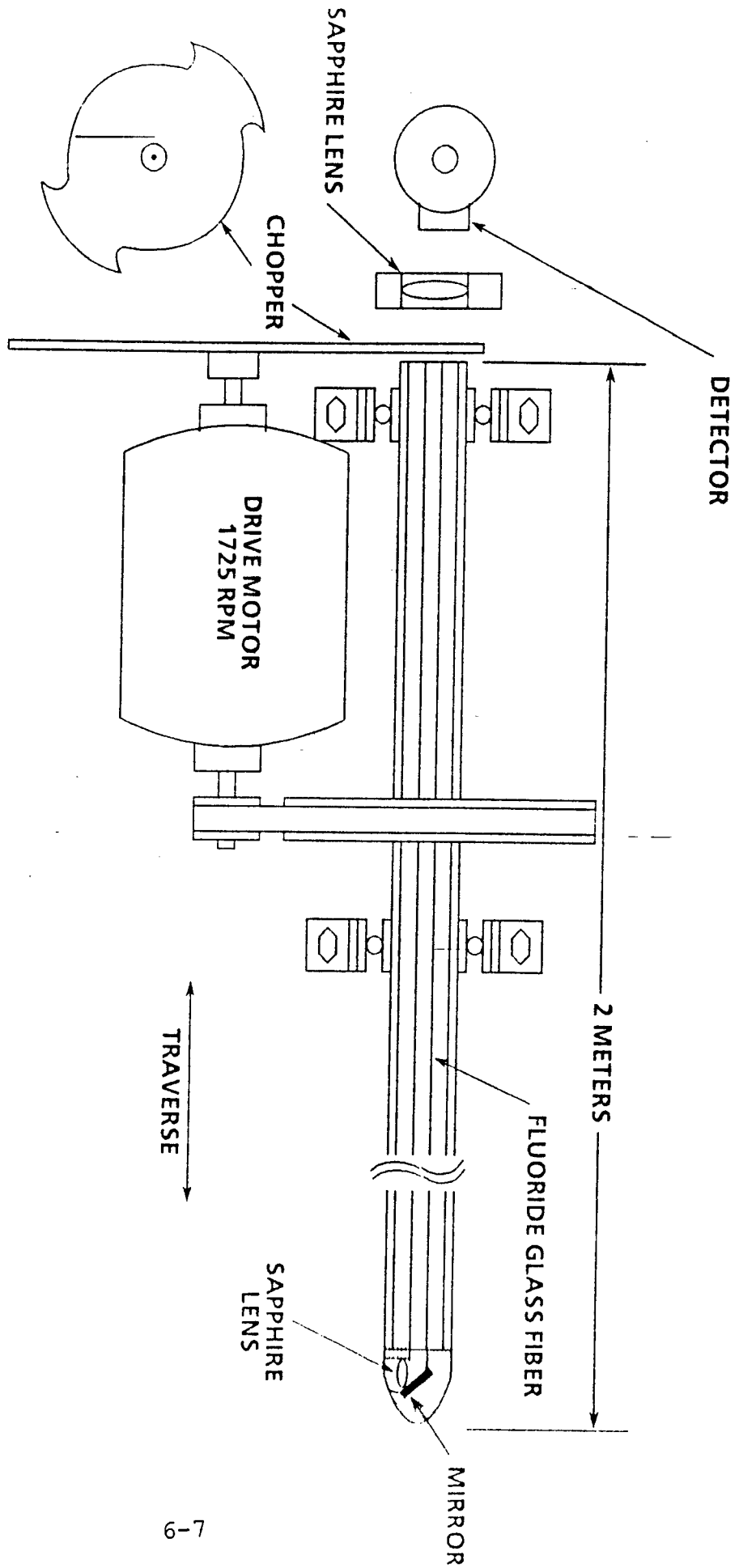
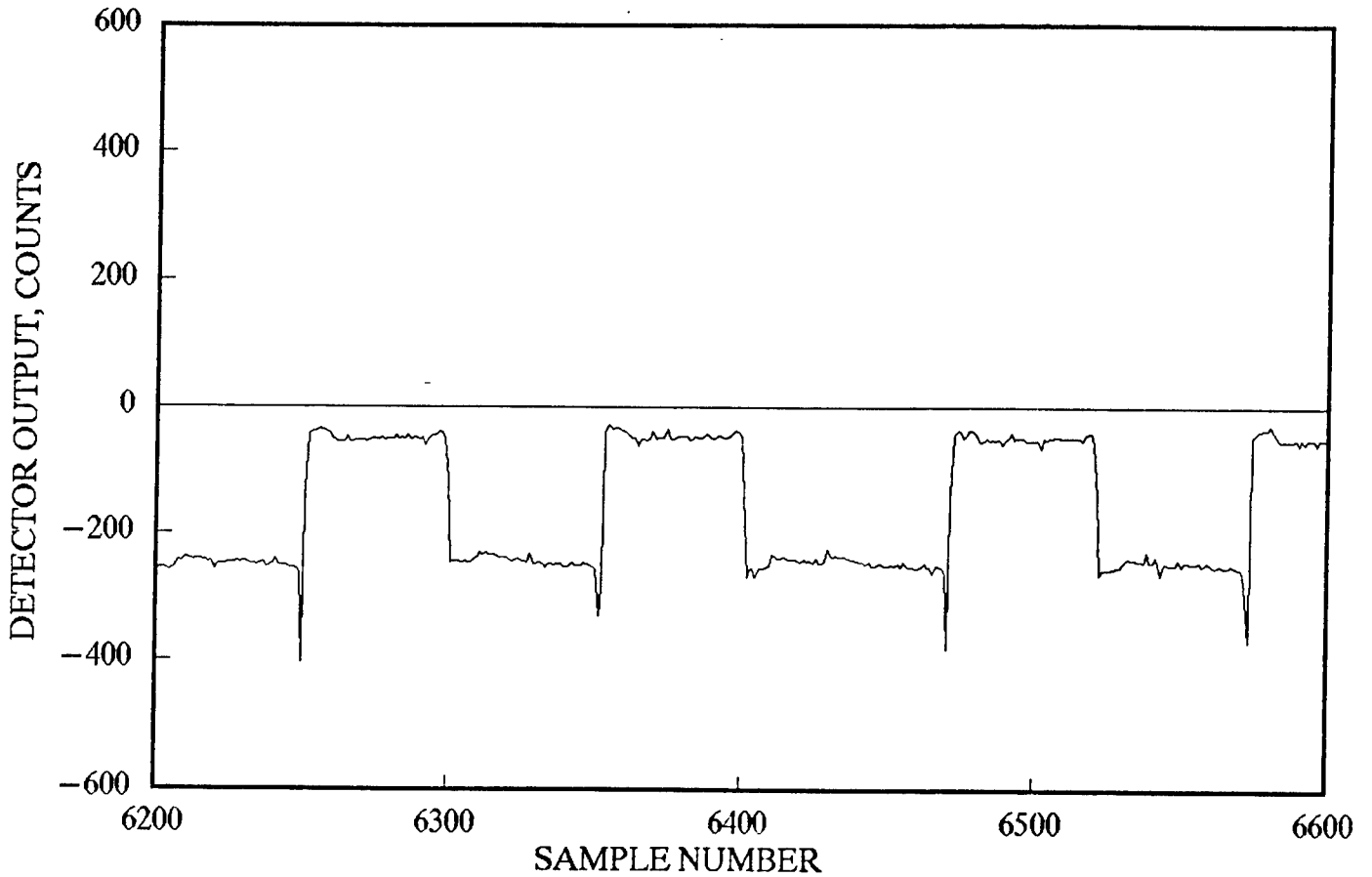

Figure 1. Breadboard Infrared Borescope.

FIGURE 2 - BEARING HEATER OFF



DATA POINT 26  
2 INCH DIA. B.B. AT 7.0 INCHES

FIGURE 3 - BEARING HEATER ON

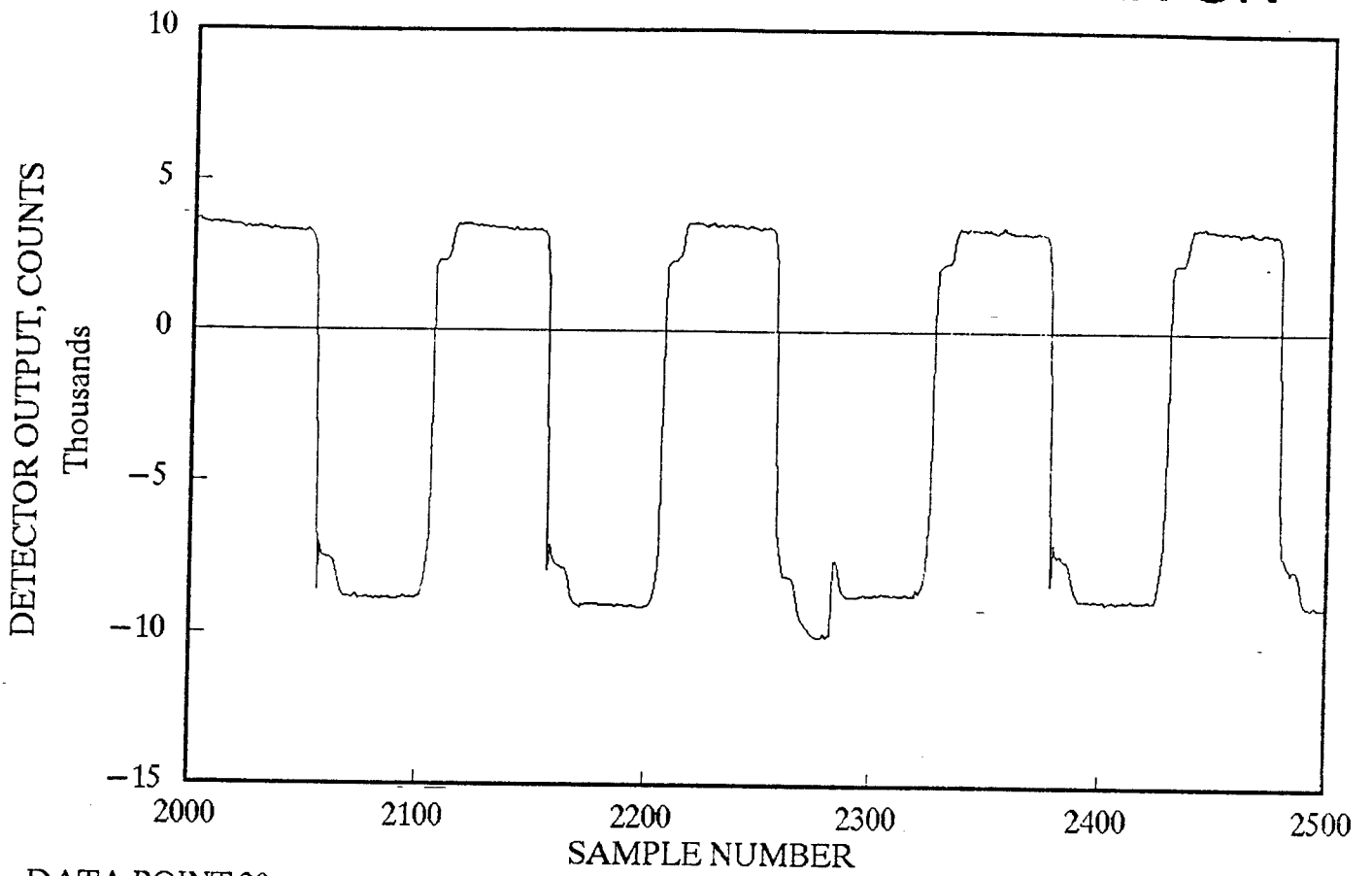

DATA POINT 29  
2 INCH DIA. B.B. AT 7.0 INCHES

Bilinear Second-Order Recursive Notch Filter

Kristy L. Price  
Graduate of Tullahoma High School  
University of Tennessee at Chattanooga

Final Report for:  
AFOSR Summer Research Program  
Arnold Engineering Development Center

Sponsored by:  
Air Force Office of Scientific Research  
Boiling Air Force Base, Washington, D.C.

August 1993

# Bilinear Second-Order Recursive Notch Filter

Kristy Price  
Graduate of Tullahoma High School  
University of Tennessee at Chattanooga

## Abstract

A filter is a device used to reject signals, vibrations, or radiations of certain frequencies while passing others. A digital filter does this process, which is often linear, on a set of discrete data numerically. In this particular project, a bilinear transformation notch filter, a second-order recursive digital filter that depends on previous outputs, was applied to data contaminated by 60 Hertz power-line interference to remove a narrow band around that frequency. A test case was developed which contained 60 Hertz noise. This test case was written into a source code as a sine function containing frequencies at 10, 60, and 100 Hertz. When the notch filter was applied, the 60 Hertz frequency was removed. In two additional tests, the filter also effectively removed the 60 Hertz noise. The sine function was modified to simulate real data by randomizing the 60 Hertz frequency between 58 and 62 Hertz. Also, the bilinear transformation notch filter was tested with data from an AEDC test cell. In both tests, the width of the notch had to be changed in order for the filter to work effectively. To filter the test cell data, the notch filter was applied at 40 Hertz instead of 60 Hertz to correct for the aliasing of the data.

# Bilinear Second-Order Recursive Notch Filter

Kristy Price

## Introduction

A filter is a device used to reject signals, vibrations, or radiations of certain frequencies while passing others. A digital filter does this process, which is often linear, on a set of discrete data numerically. Many digital filters are used to eliminate noise at various frequencies. High-pass or low-pass filtering eliminates noise at low or high frequencies, respectively. A bandpass filter allows only one frequency to pass, while a notch filter removes a specific frequency only. In this particular project, a bilinear transformation notch filter, a type of second-order recursive digital filter, was applied to data contaminated by 60 Hertz power-line interference to remove a narrow band around that frequency. A test case was developed which contained 60 Hertz noise. This test case was written into a FORTRAN source code as a sine function containing frequencies at 10, 60, and 100 Hertz. When the notch filter was applied, the 60 Hertz frequency was removed. This filter has been applied to actual test data. The notch filter was effective in removing the 60 Hertz noise from AEDC test cell data. Therefore, this filter is widely applicable to such testing operations.

## Acknowledgements

The author would like to thank her mentor Woody Dorrell for his time and patience and for making this project possible. Also much gratitude is given to Tommy Heard for his help on the personal computer. Thanks is also extended to all the AEDC personnel who helped make this summer an enjoyable learning experience.

## Description

The purpose of this project was to design a digital filter which would remove from a signal the 60 Hertz noise that comes

from the electrical power distribution system. A program written in the FORTRAN programming language computed two composite sine functions. The function to be tested contained frequencies at 10, 60, and 100 Hertz. The other sine function contained only the 10 and 100 Hertz frequencies and acted as a control for the project. These equations are located in Figure 1. The 60 Hertz frequency was filtered from the sine function by two different methods. It was first filtered manually from the function. The data was run through a Fast Fourier Transform (FFT) which transposed the data into the frequency domain. The 60 Hertz spike and its symmetric component were set to zero. An inverse FFT returned the filtered data to the time domain. The filtered test function when compared to the control function was a perfect match.

Next, an attempt was made to filter the 60 Hertz noise digitally from the original test function in the time domain. A notch filter which would remove a very narrow frequency band was needed. After library research was done, a bilinear transformation notch filter taken from Numerical Recipes in Fortran: The Art of Scientific Computing was added to the program. This filter is shown in Figure 2. Coefficients denoting a notch filter were calculated in a subroutine. The user supplied the desired frequency (in this case 60 Hertz) and width of the notch. A parametric study on the notch width determined the latter parameter. These filter coefficients were then passed to another subroutine which applied the formula for a general linear filter. This formula can be seen in Figure 1. As the function passed through the notch filter, the 60 Hertz frequency band was removed. Many techniques were tested in order to improve the filter, but attempts to sharpen the filter further by smoothing the data or filtering twice were unsuccessful.

In two additional tests, the filter was also effective in removing the 60 Hertz noise. The sine function was first modified to simulate real data. The 60 Hertz frequency was randomized between 58 and 62 Hertz by adding a random number

generator to the program. This data effectively filtered, the bilinear transformation notch filter was then tested with data from an AEDC test cell. It was discovered that the filter was effective in removing 60 Hz noise only if the filter was applied at 40 Hz. This was necessary because of the aliasing (folding back) of the data.

After this project was completed, three other types of filters were examined. Two nonrecursive filters, which were independent of previous outputs, were studied so that the author could understand the difference between recursive filters and nonrecursive filters. These filters were the least-squares formula and smoothing by five's. A third filter, a Butterworth low-pass filter, was attempted without success.

### Results

The first filter process, performed by manually setting the 60 Hertz frequency to zero through the use of a FFT, was successful in filtering the data in the frequency domain.

The bilinear transformation notch filter also worked well for times greater than 0.10. As seen in figure 3, at times less than this value the filter was less accurate. Attempts to correct this problem were not successful. Graphs of the unfiltered and filtered function in the frequency domain are shown in Figures 4 and 5.

The test function was compared to the control function by calculating the distance between the functions and by plotting the graphs on the same plot and observing the differences. The results were verified with a plot of the control function containing 10 and 100 Hertz frequency bands. The maximum calculated difference between the functions was 0.848. The sum of the differences at the 1024 points of the function was 145.

This filter had some limitations. The filter operated best with a notch width of three. Also, for the calculation of the filter coefficients, it was assumed that the user will supply the fiducial frequency rather than the frequency. (Fiducial

frequency equals the tangent of  $\pi * \text{frequency} * \text{delta time}$ .) The filter was limited in that the user must supply initial values for  $x(-2)$ ,  $x(-1)$ ,  $y(-2)$ ,  $y(-1)$ , and  $y(0)$  of which  $x$  was the unfiltered function and  $y$ , the filtered. These values were set to zero.

The modified test case where the 60 Hertz noise was spread out between 58 to 62 Hertz also worked fairly well. A wider notch width of twelve was necessary to remove all of the frequency band. These graphs of the unfiltered and filtered modified function are seen in Figures 6 and 7.

When the bilinear transformation notch filter was applied to the test cell data, a notch width of ten was necessary for the filter to remove most of the 60 Hertz frequency which appeared as 40 Hertz on the graph. Unfiltered and filtered function graphs in the frequency domain can be seen in figures 8 and 9.

### Conclusion

A bilinear transformation notch filter was applied to remove the 60 Hertz noise from test data. By changing the notch width, this filter worked well for removing this frequency from a composite sine function, a sine function simulating real data, and data from a test cell.

### Observations

I believe this program has been a very worthwhile experience. I have learned much about AEDC, FORTRAN, and computer programming. I believe this summer experience will help me in my engineering major in college. This program is an excellent program. I would highly recommend it to an interested student. My only wish is that this program be made even better by its expansion to include more students in the future.

## References

Press, W.H., et al. Numerical Recipes in Fortran: The Art of Scientific Computing. Cambridge UP, New York, 1992 (Second Edition.)

Hamming, R.W. Digital Filters. Prentice-Hall Inc, Englewood Cliffs, New Jersey, 1977.

Composite Sine Function Equations:

Equation 1 (Test)

$$y = 2\sin(\pi*f1*t) + \sin(\pi*f2*t) + \sin(\pi*f3*t)$$

where

$$f1 = 10 \text{ Hz}$$

$$f2 = 60 \text{ Hz}$$

$$f3 = 100 \text{ Hz}$$

$$t = \text{time from } 0.0 \text{ to } 0.3$$

Equation 2 (Control)

$$y = 2\sin(\pi*f1*t) + \sin(\pi*f3*t)$$

where

$$f1 = 10 \text{ Hz}$$

$$f3 = 100 \text{ Hz}$$

$$t = \text{time from } 0.0 \text{ to } 0.3$$

General Linear Filter Formula:

$$y_n = \sum_{k=0}^M c_k x_{n-k} + \sum_{j=1}^N d_j y_{n-j}$$

Figure 1

# Bilinear Transformation Notch Filter Filter Function

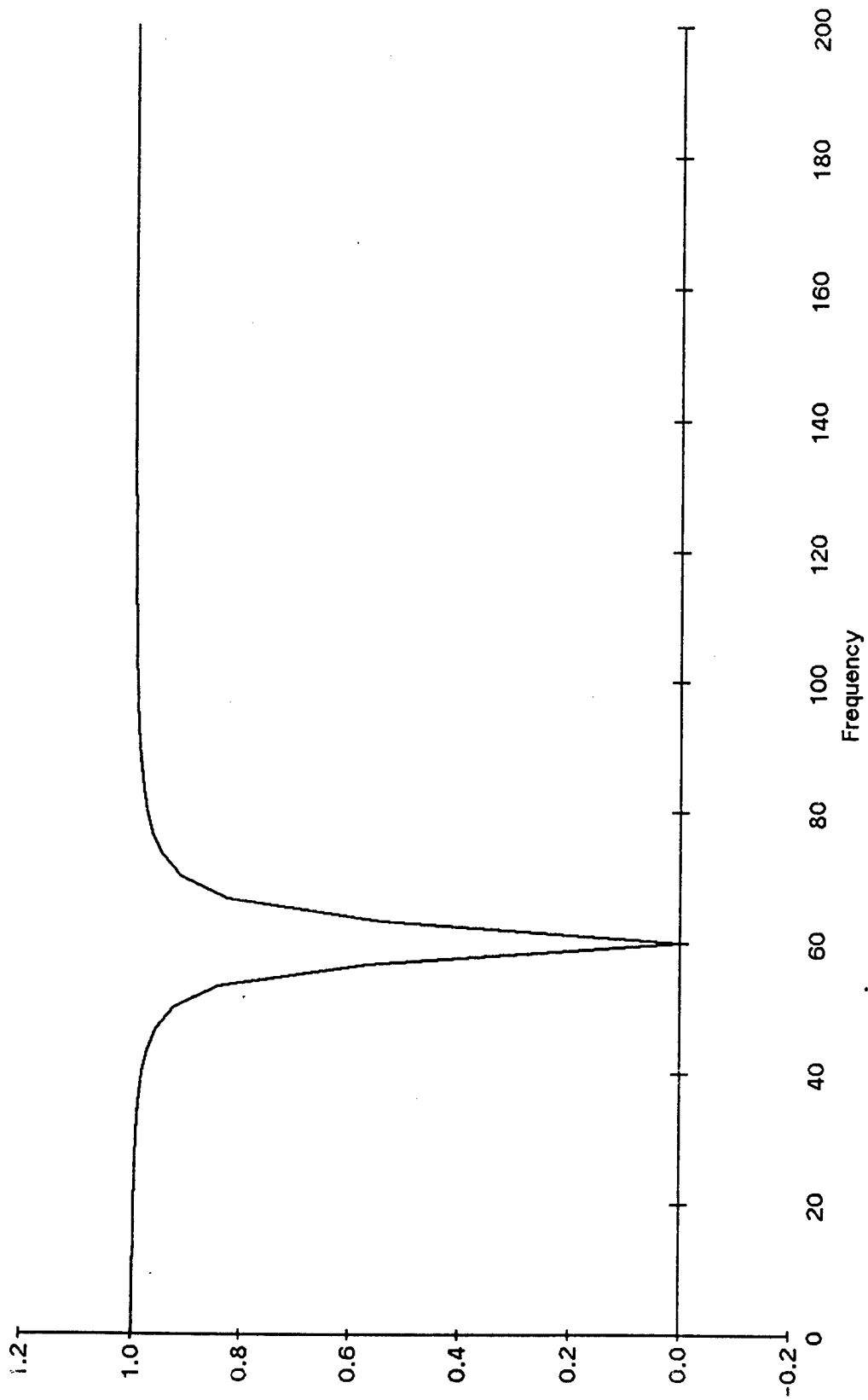

Figure 2

**Bilinear Transformation Notch Filter**  
at 60 Hz. EPS = .05 T,B(I),Y(I)

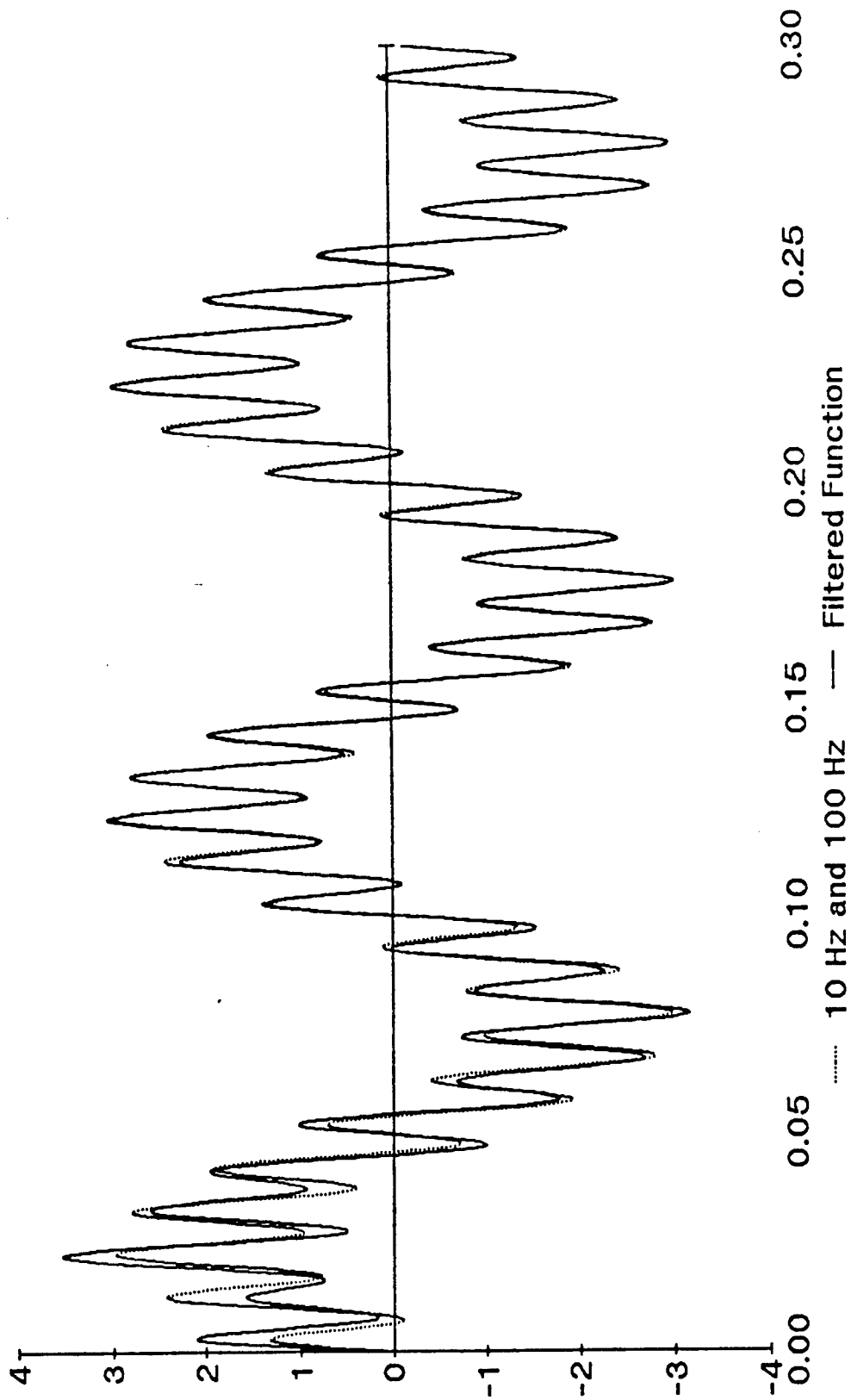

Figure 3

# Unfiltered Sine Function

$\Delta t = .000292$   $\text{Eps} = .05$

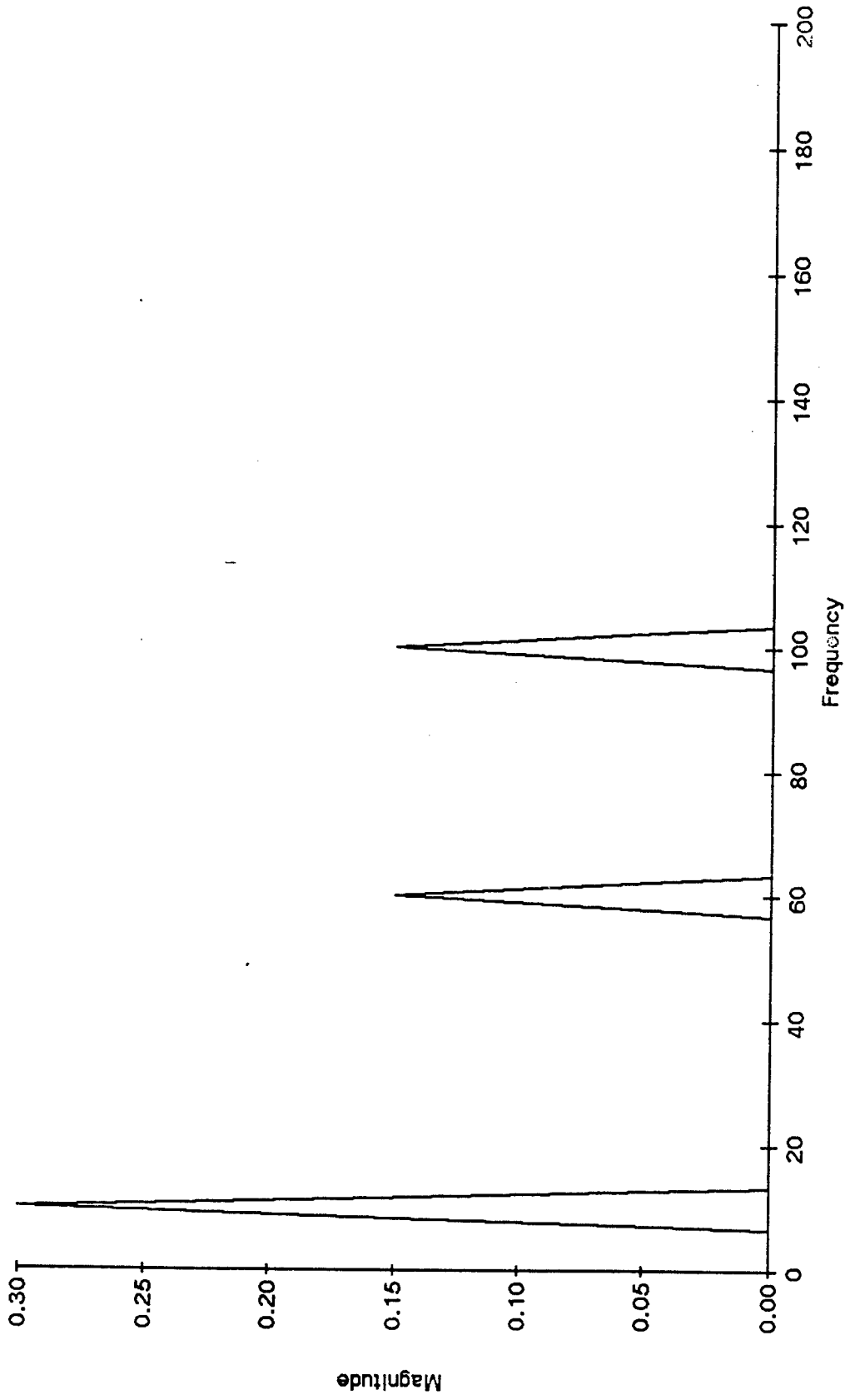

Figure 4

# Bilinear Transformation Notch Filter

at 60 Hz. Delt = .000292 Eps = .05

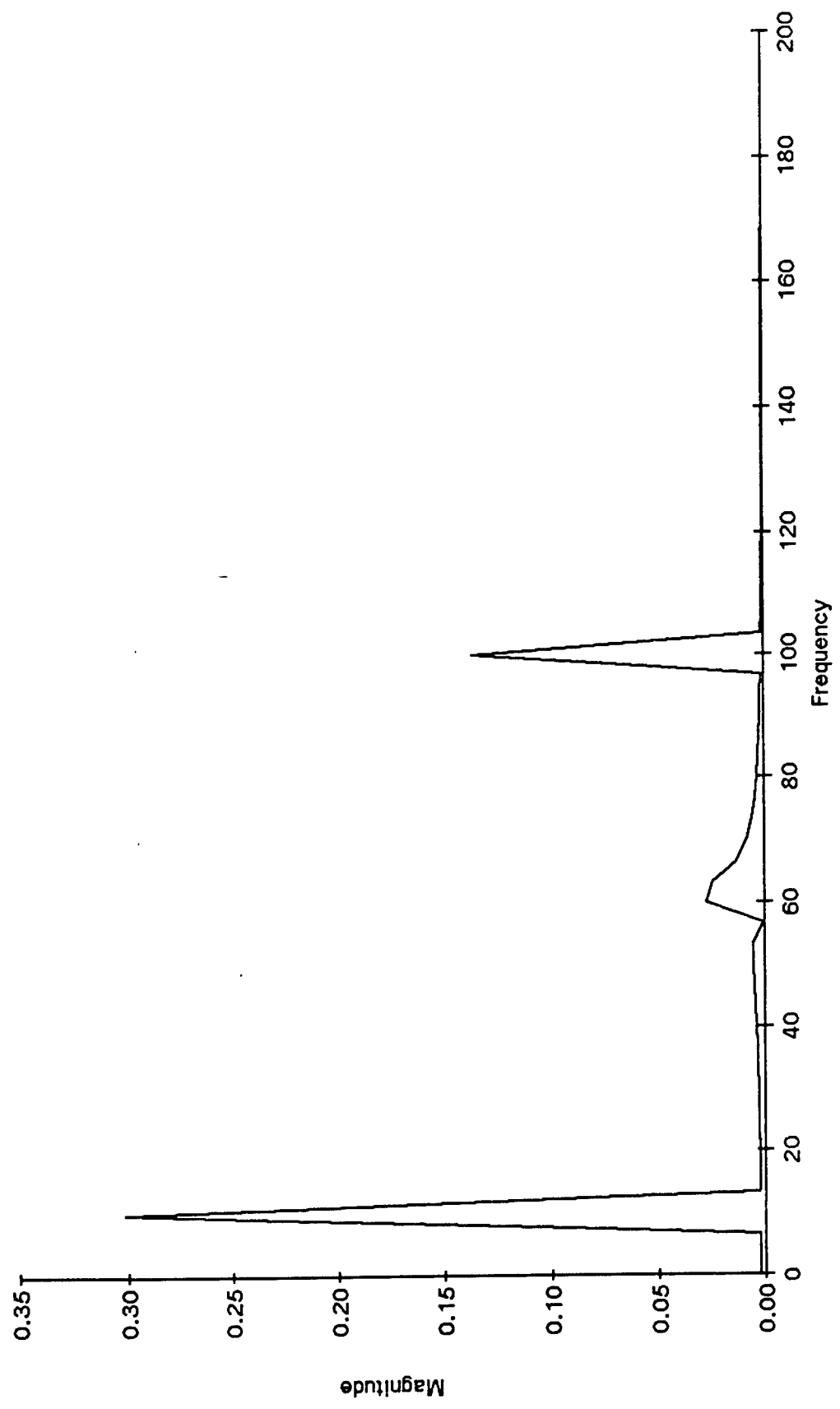

Figure 5

# Sine Function

Randomized Unfiltered Data

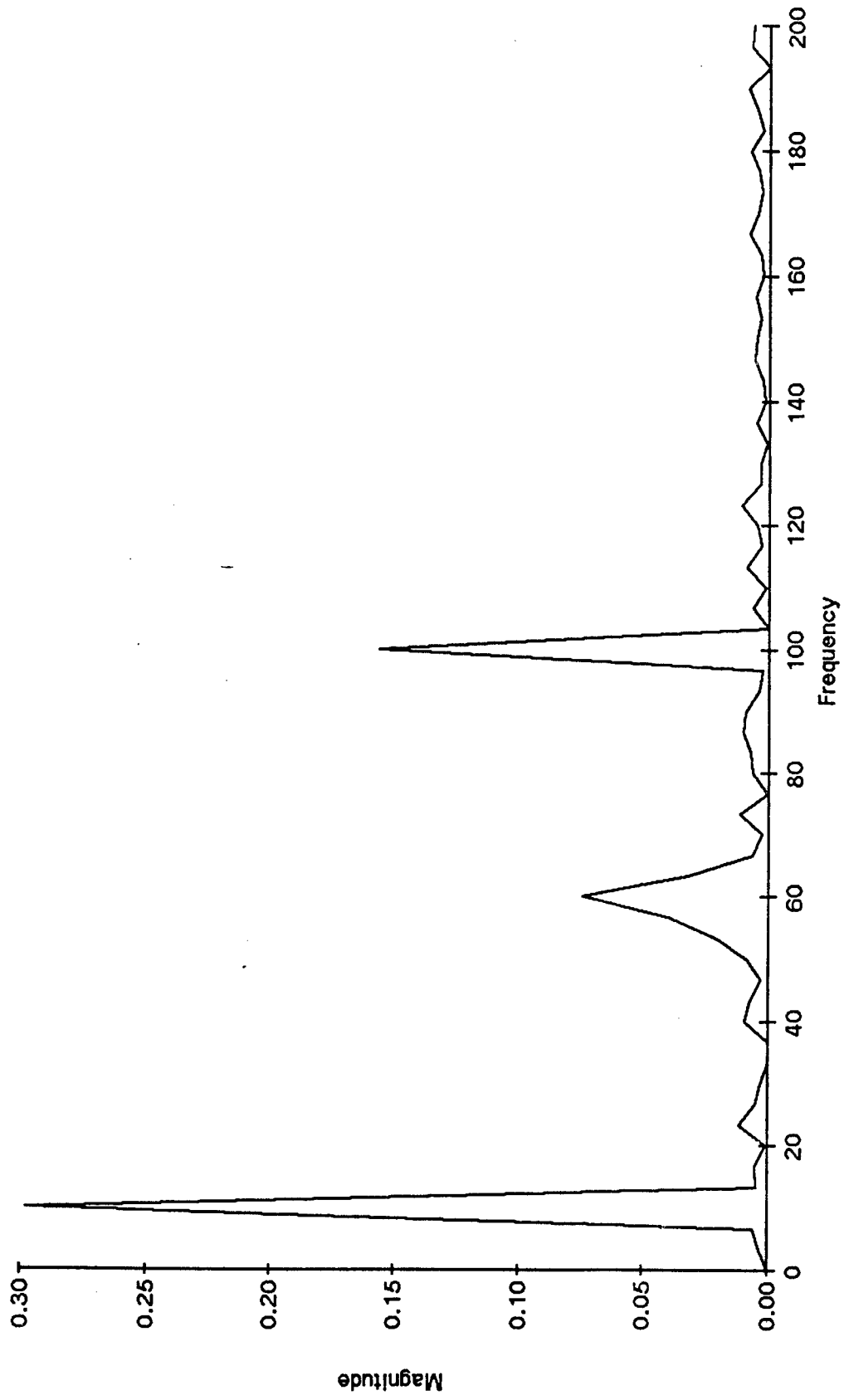

Figure 6

# Bilinear Transformation Notch Filter

at 60 Hz. Eps= .2 Random

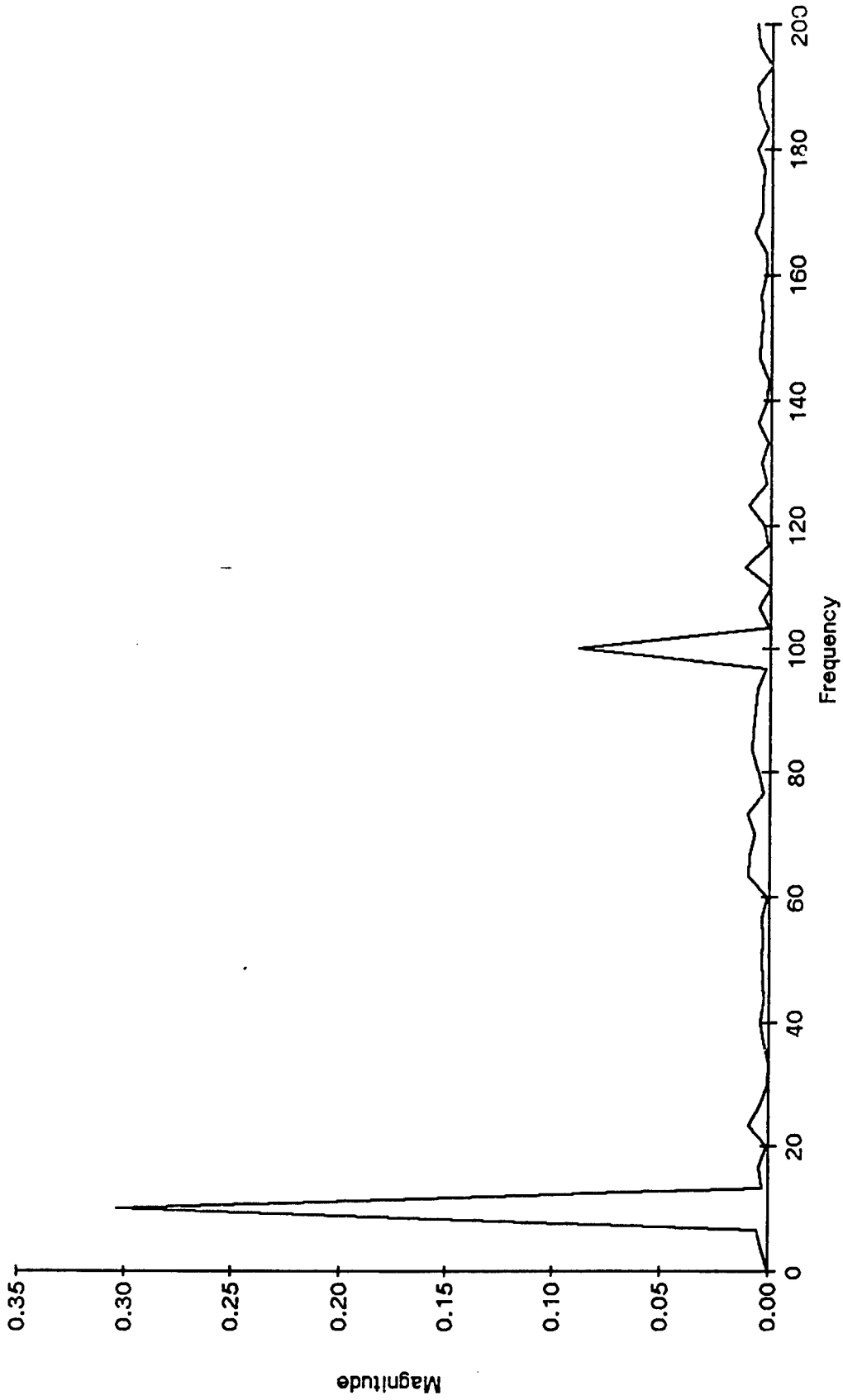

Figure 7

# Unfiltered Test Cell Data

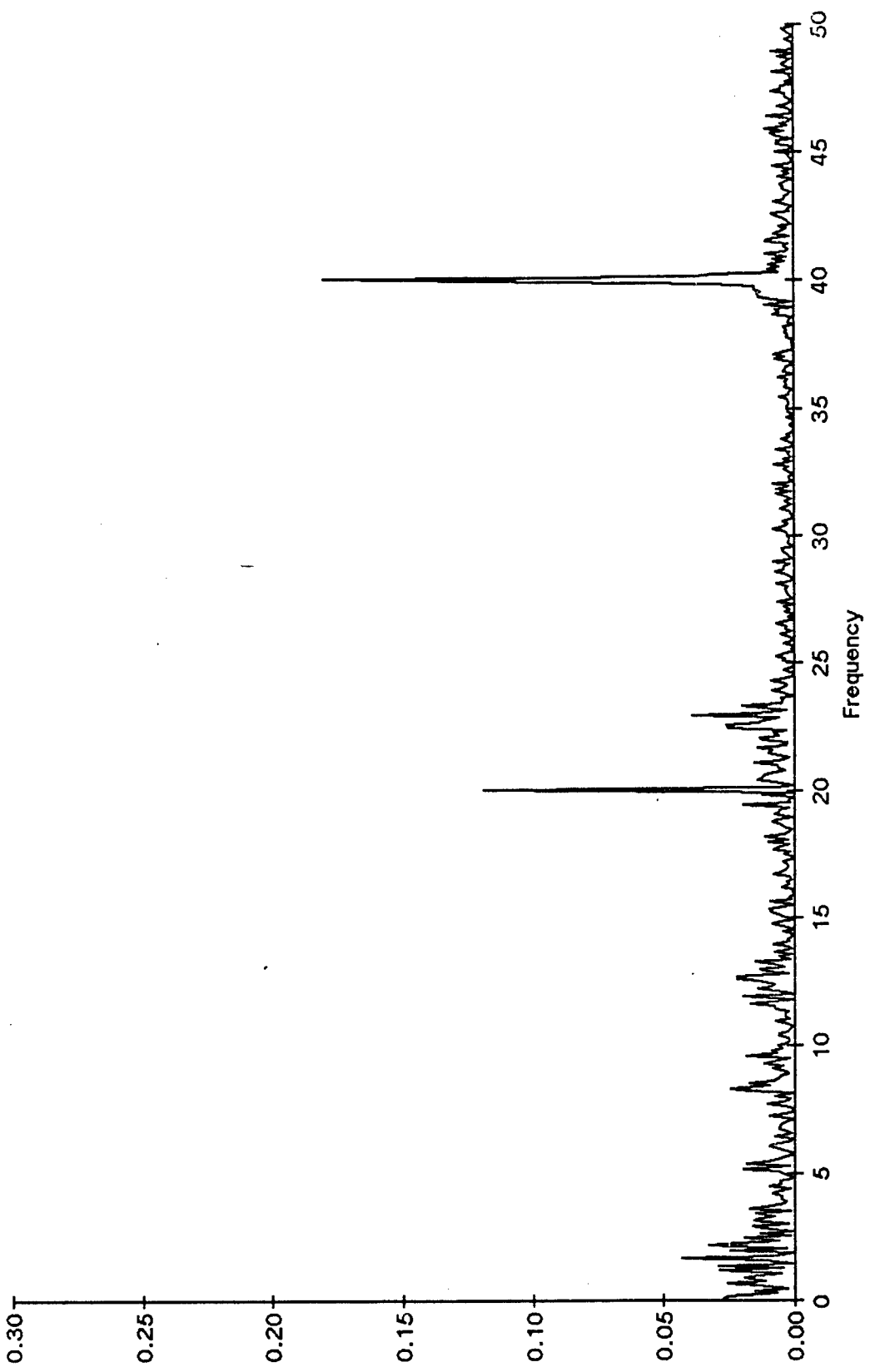

Figure 8

**Bilinear Transformation Notch Filter**

Test Cell Data EPS = .25

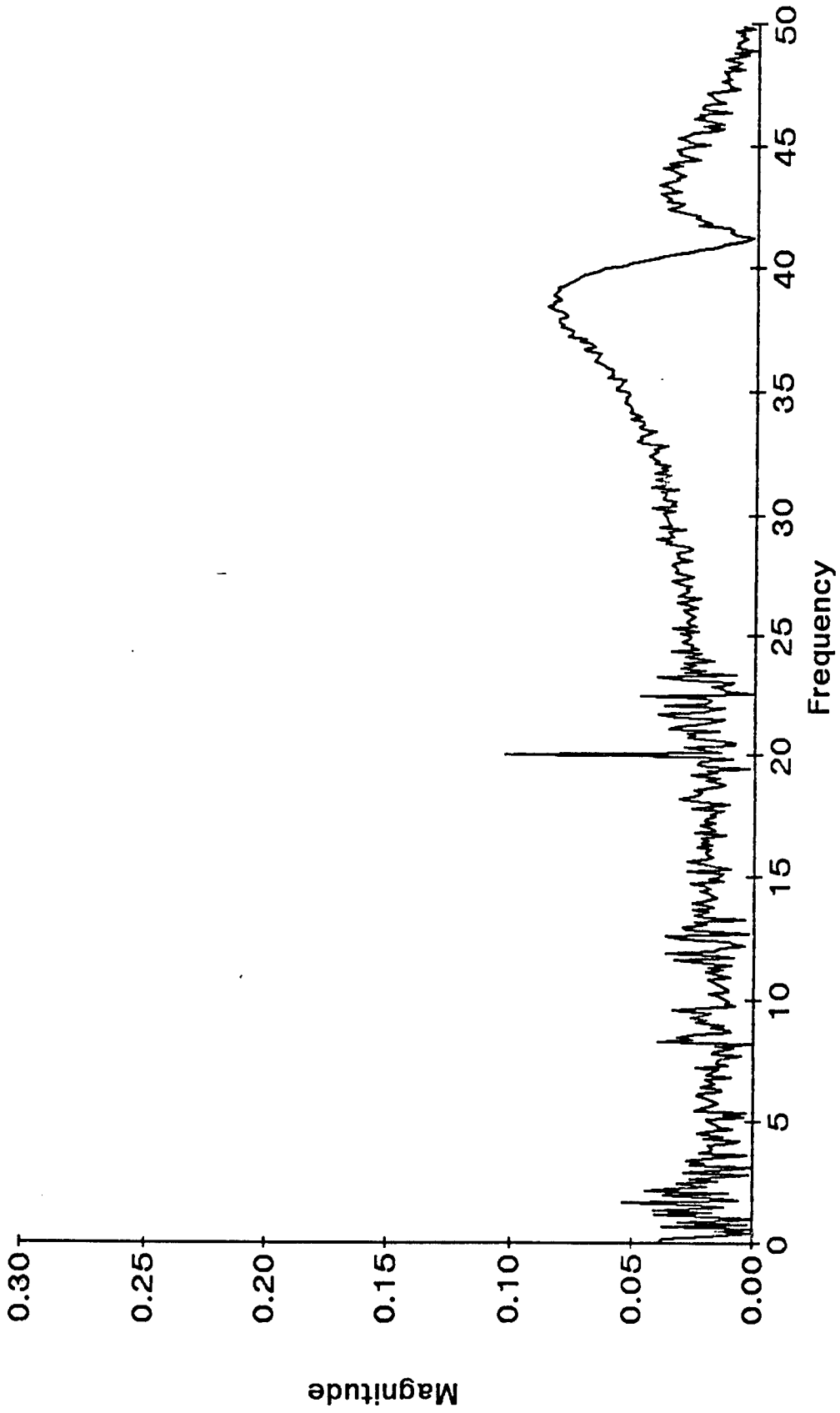

Figure 9

THE ANGULAR ROTATION MATRIX EXPANSION TABLE CALCULATOR

Kris S. Ray

Bill Crosby

Calspan

Final Report for:

Summer Research Extension Program  
Arnold Engineering Development Center

Sponsored by:

Air Force Office of Scientific Research  
Arnold Air Force Base, Tullahoma, TN

August 1993

# THE ANGULAR ROTATION MATRIX EXPANSION TABLE CALCULATOR

Kris S. Ray

## Abstract

My main project this summer was to make a user friendly program that multiplies angular rotation matrices in symbolic form. The program utilizes the easy to use Windows operating systems and all controls are intuitive. This program will aid in future testing at AEDC.

# THE ANGULAR ROTATION MATRIX EXPANSION TABLE CALCULATOR

Kris S. Ray

## Introduction

In most aerodynamics applications, more than one rotation of the axes system is required to obtain all of the necessary data vital to a test. I was asked to create a program to expand the angular rotation matrices in symbolic form. This program transforms vectors through multiple axes and displays the answer symbolically. The program was necessary to help determine the primary factors in a rotation series and to find out when one matrix cancels out another.

## METHODOLOGY

The method by which I chose to approach this program was to create it as a Windows based program. To do this I had to write it in the language Visual Basic. The first step was to setup the control panel and display boxes(Fig 1). The second step was to program in the base rotation matrices of Phi, Psi, and Alpha(Fig 2). After that was completed the most difficult part of the programming began. Normally the part of the program that actually multiplies the matrices would be a simple task, but for the purposes of this program it had to be able to multiply each cell of the matrices symbolically. All of the cells in each matrix had to be inputted as string variables. Once this was

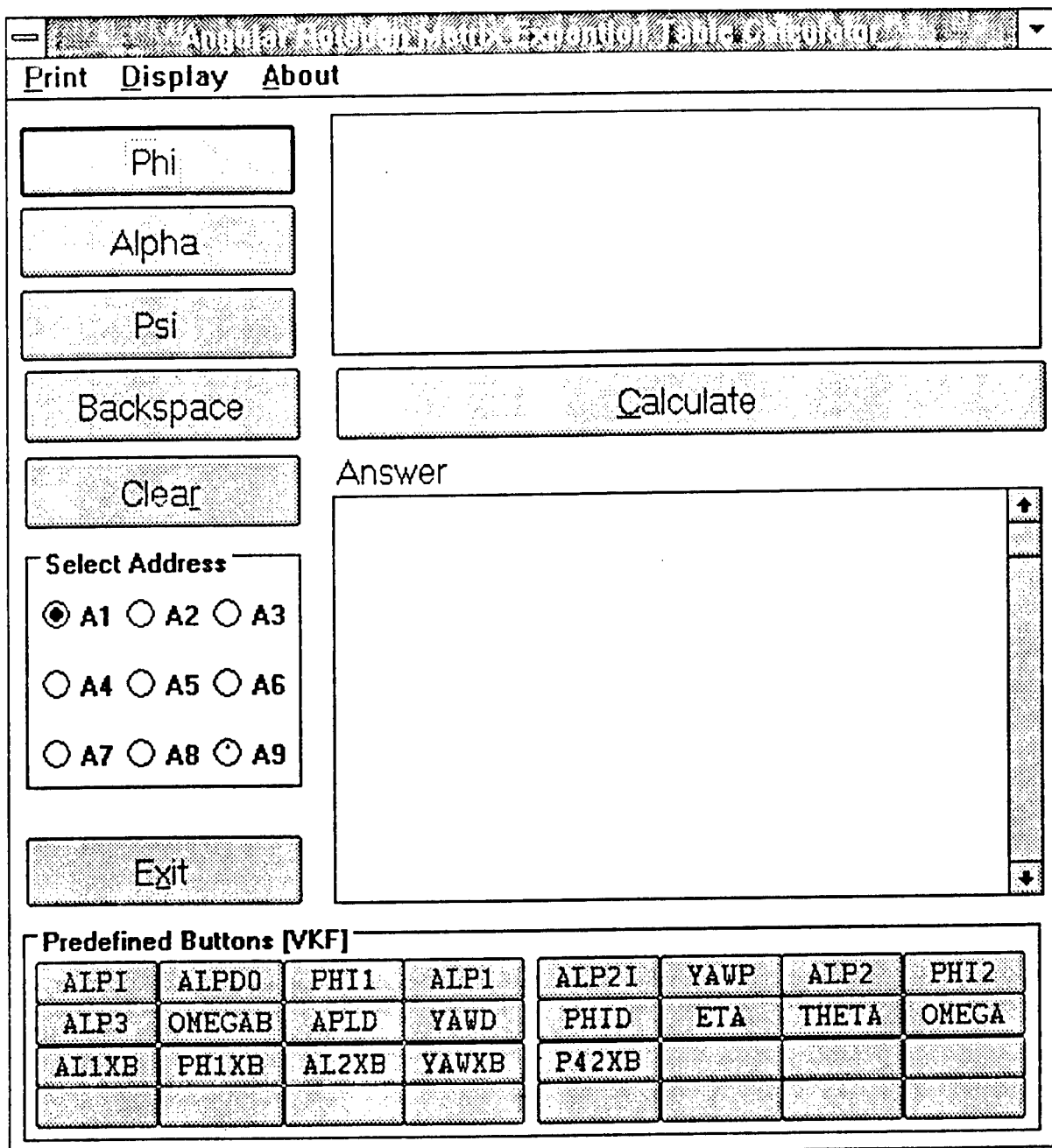

Figure 1

# Rotation Matrices

- **roll**

1	0	0
0	$\cos(\phi)$	$\sin(\phi)$
0	$-\sin(\phi)$	$\cos(\phi)$

- **pitch**

$\cos(\alpha)$	0	$-\sin(\alpha)$
0	1	0
$\sin(\alpha)$	0	$\cos(\alpha)$

- **yaw**

$\cos(\psi)$	$\sin(\psi)$	0
$-\sin(\psi)$	$\cos(\psi)$	0
0	0	1

Figure 2

accomplished and and a few check problems had been run I began to work on the next phase of the project. This phase entailed creating an array of predefined buttons which are actually Phi, Psi, and Alpha but they have different names based on their notation. For the predefined buttons to work properly I had to create a subprogram to translate the predefined buttons into the matrices of Phi, Psi, or Alpha and to rename the unit to whatever the predefined button's name is. After this was completed I made changes that expanded the parenthesis which appeared in earlier versions of my program.

#### PROBLEMS

Although the program multiplies the angular rotation matrices correctly, it does have some limitations. One of the limitations is that the Visual Basic programming language can only handle 64K of string space, and the program will shut down if the 64K limit is exceeded. Another limitation is that processing time increases exponentially with each additional matrix that is multiplied and the calculation time is no longer practical after about 12 matrices(Fig 3).

#### RESULTS

The result of the project was that an easy to use program that expands the angular rotation matrices in symbolic form was created. The program is however limited to about 12 rotations due to processing time and the 64K string barrier.

# Required Calculation Time on a 486-DX 50

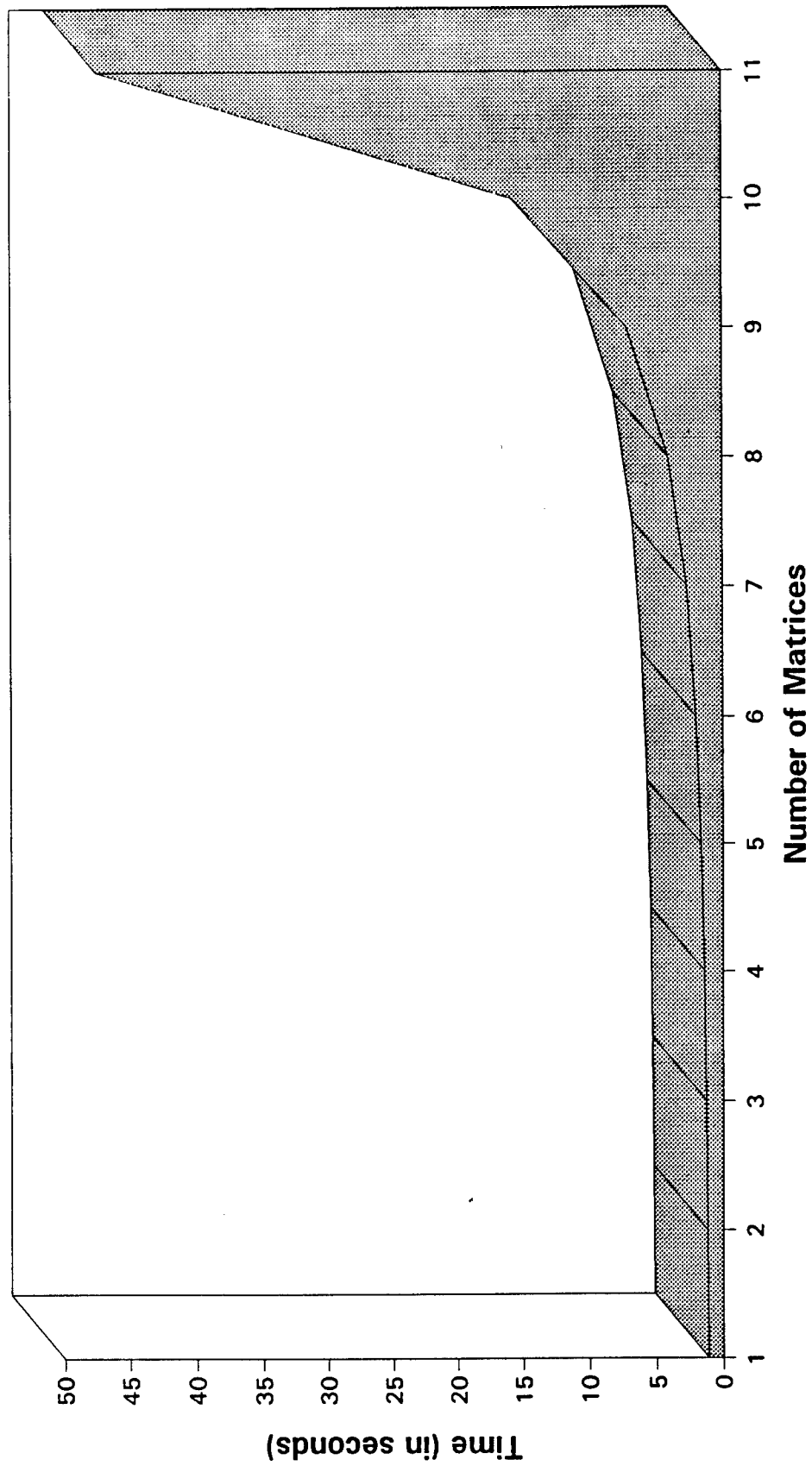

Figure 3

Thanks to:

Bill Crosby

James Mitchell

Wayne Hawkins

Ed Marquart

Gil Morton

Special Thanks to:

Benji York - for assisting in program design

**TOOL KIT PROGRAM  
(WRITTEN IN FOXPRO)**

**Cheryl Riddle**

**Moore County High School  
Lynchburg, Tennessee**

**Mentor:**

**Ms. Valerie Mayes**

**Sponsored by:**

**Arnold Air Force Base  
Tullahoma, Tennessee**

**August 1993**

**TOOL KIT PROGRAM  
(WRITTEN IN FOXPRO)**

**Cheryl Riddle  
Moore County High School  
Lynchburg, Tennessee**

**ABSTRACT**

This computer program was written using FoxPro 2.0. The program creates a database for the tool crib of the Engine Test Facility at Arnold Engineering Development Center. Currently in use is a very limited database file that will be replaced by this program. Through the new program, there will be a complete database of all employees, tools, inventory codes, and craft codes. Employees can be linked and unlinked to their craft and their tools, inventory sheets can be comprised and printed by the computer, inventory can be completely recorded by the computer, and reports can be generated over all aspects of the job.

## **TOOL KIT PROGRAM (WRITTEN IN FOXPRO)**

**Cheryl Riddle**

Here at the Arnold Engineering Development Center, the Engine Test Facility Tool Crib is in need of a method to increase the efficiency and accuracy of its administration. This summer we have written a program to help make this possible. Currently in use is a very limited database which this program will replace. It will create a complete database of all employees, tools, inventory codes, and craft codes. Employees can be linked and unlinked to their tools and to their craft. Inventory sheets can be comprised and printed by the computer, and the computer can completely record all inventory data for up to three inventory periods (three years). The program can also generate reports over almost every imaginable aspect of a job. What follows is a detailed explanation of the workings of the program we have written.

### **TOOL KIT PROGRAM**

#### **TOOL KIT MAIN MENU**

1. ACCESS EMPLOYEE FILE
2. ACCESS TOOL FILE
3. ACCESS CODE FILE
4. LINK/UNLINK TOOLS TO TOOL BOX
5. SWITCH AND COPY TOOL BOXES
6. INVENTORY
7. REPORTS
8. ACCESS CRAFT FILE
9. RETURN TO MAIN MENU

- Each employee has one tool box. An employee's badge number is also that employee's tool box number.
- Each tool box is linked to specific tools. Tools are identified by a unique tool number and a unique stock number.
- There is a specific set of tools for a particular craft. Therefore an employee is related to a craft and a tool is related to craft(s).
- Each tool has a specific cost.
- Inventory duration is every 365 days/4 boxes per week (Mon-Thur), excluding holidays. The computer will

generate the initial inventory schedule. After that, inventory will be taken again every 365 days. The next inventory date can be overwritten in the ACCESS EMPLOYEE FILE option.

- Each tool within a tool box will be assigned a specific inventory code.

## **ACCESS EMPLOYEE FILE**

<p><b>EMPLOYEE FILE MENU</b></p> <ol style="list-style-type: none"><li>1. ADD/EDIT EMPLOYEE FILE</li><li>2. DELETE FROM EMPLOYEE FILE</li><li>3. EMPLOYEE REPORT</li><li>4. RETURN TO MAIN MENU</li></ol>
---

### **1. ADD/EDIT EMPLOYEE FILE**

<p>BADGE NUMBER: _____</p> <p>LAST NAME: _____ INITIALS: _____</p> <p>CRAFT CODE: _____ ORGANIZATION CODE: _____</p> <p>DATE OF INVENTORY: ___/___/___</p>
--

- Enter badge number to retrieve record. If badge number does not exist, a new record is created.
- If badge number not known, press F2 to scan employee file (file ordered by last name). Highlight record and hit ESC to return with employee record selected.
- Date of next inventory can be changed. However, if automatic inventory is selected, this date may be overwritten.
- If badge number changes, the corresponding badge number in LINK and HISTORY files is also changed. User must confirm that the badge number is being changed.
- Cannot have duplicate badge numbers.

### **2. DELETE FROM EMPLOYEE FILE**

- Enter badge number to retrieve record (same screen as ADD/EDIT EMPLOYEE FILE). Press F2 to scan list.
- User must confirm before actually deleting record.
- If there are tools linked to a badge number, computer automatically unlinks tools and deletes badge. User must confirm this first.

### 3. EMPLOYEE REPORT

- REPORT ON: SPECIFIC ORGANIZATION  
ENTER ORG CODE> \_\_\_\_\_  
SPECIFIC EMPLOYEE  
ENTER BADGE NUMBER> \_\_\_\_\_  
(OR PRESS F2 TO SCAN EMPLOYEE FILE)

(Place a value in a blank above to report on just one organization or just one employee. Otherwise report on all employees in the database.)

- SORT BY: NAME (N) \_\_\_\_\_  
BADGE NUMBER (B) \_\_\_\_\_

(Place a value beside the sort order desired. Otherwise order will be by name.)

- SEND OUTPUT TO SCREEN OR TO PRINTER  
(If sent to screen, still have option of printing to printer afterwards.)
- Report will look like the following:

<u>BADGE#</u>	<u>NAME</u>	<u>CFT</u>	<u>ORG</u>	<u>LAST INV</u>	<u>NEXT INV</u>
12777	Mayes, VR	PF	EM7	05/15/93	03/15/94
12778	Baker, JR	EL	EM7	05/16/93	03/16/94
12789	Hampton, SK	PF	ES4	05/19/93	03/19/94

- Ability to escape screen report when desired

### ACCESS TOOL FILE

#### TOOL FILE MENU

1. ADD/EDIT TOOL FILE
2. DELETE FROM TOOL FILE
3. TOOL REPORT
4. RETURN TO MAIN MENU

#### 1. ADD/EDIT TOOL FILE

TOOL NUMBER: \_\_\_\_\_ STOCK NUMBER: \_\_\_\_\_  
DESCRIPTION: \_\_\_\_\_  
CATEGORY: \_\_\_\_\_ COST: \$ \_\_\_\_\_  
DO YOU WISH TO ASSIGN THIS TOOL TO CRAFTS? Y/N \_\_\_\_\_

- Enter tool number, stock number, or key word in description. If record does not exist, a new record is created.

- If tool number or stock number unknown, press F2 to scan tool file (file ordered by either tool number or stock number). Highlight choice and hit ESC to return with record selected.
- If entering key word, scan tool file for closest match (file ordered by description). Highlight record and hit ESC to return with tool record selected.
- If tool number is changed, the corresponding tool number in LINK, HISTORY, and CFTLIST files is also changed. User must confirm that the tool number is being changed.
- Cannot have duplicate tool numbers or duplicate stock numbers.
- When assigning tool to crafts, show list of valid crafts. Select the craft by marking it with an X. CTRL+W to exit and save.

## 2. DELETE FROM TOOL FILE

- Enter tool number, stock number, or key word to retrieve record (same screen as ADD/EDIT TOOL FILE). Press F2 to scan list.
- User must confirm before actually deleting record.
- Cannot delete a tool if there are badges linked to it. (Must unlink first.)

## 3. TOOL REPORT

- REPORT ON: SPECIFIC TOOL  
ENTER TOOL NUMBER> \_\_\_\_\_  
(OR PRESS F2 TO SEARCH TOOLS)  
(Place a value in blank above to report on just one tool. Otherwise report on all tools in the database.)
- LIST VALID CRAFTS FOR THIS TOOL? Y/N \_\_\_\_\_
- SORT BY: TOOL NUMBER (T) \_\_\_\_\_  
STOCK NUMBER (S) \_\_\_\_\_  
DESCRIPTION (D) \_\_\_\_\_  
(Place a value beside the sort order desired. Otherwise order will be by description.)
- SEND OUTPUT TO SCREEN OR PRINTER  
(If sent to screen, still have option of printing to printer afterwards.)
- Report will look like the following:

Without crafts:

<u>TOOL#</u>	<u>STOCK#</u>	<u>CATEGORY</u>	<u>DESCRIPTION</u>	<u>COST</u>
001	5380235023	Drill	Power Drill with 110V requirement	90.00
002	1235123541	Screw	Screw, flat	5.00
			TOTAL	----- 95.00

With crafts:

<u>TOOL#</u>	<u>STOCK#</u>	<u>CATEGORY</u>	<u>DESCRIPTION</u>	<u>COST</u>
002	1235123541	Screw	Screw, flat	5.00

CRAFTS

PF

BM

TOTAL 5.00

- Ability to escape screen report when desired.

## ACCESS CODE FILE

### CODE FILE MENU

1. ADD/EDIT CODE FILE
2. DELETE FROM CODE FILE
3. CODE REPORT
4. RETURN TO MAIN MENU

### 1. ADD/EDIT CODE FILE

INVENTORY CODE: \_\_\_\_\_  
DESCRIPTION: \_\_\_\_\_

- Enter inventory code. If record does not exist, a new record is created.
- If inventory code not known, press F2 to scan inventory code file (file ordered by code). Highlight record and hit ESC to return with code record selected.
- If the inventory code changes, the corresponding inventory code in LINK and HISTORY files is also changed. User must confirm that the inventory code is being changed.
- Cannot have duplicate inventory codes.

### 2. DELETE FROM CODE FILE

- Enter inventory code to retrieve record (same screen as ADD/EDIT CODE FILE). Press F2 to scan choices.
- User must confirm before actually deleting record.
- Cannot delete an inventory code if there are badges linked to it. (Must unlink first.)

### 3. CODE REPORT

- SORT BY: INVENTORY CODE (C) \_\_\_\_\_  
INVENTORY DESCRIPTION (D) \_\_\_\_\_

(Place a value beside the sort order desired. Otherwise order will be by code.)

- SEND OUTPUT TO SCREEN OR PRINTER

(If sent to screen, still have option of printing to printer afterwards.)

- Report will look like the following:

<u>INVENTORY CODE</u>	<u>CODE DESCRIPTION</u>
X	Accounted for
M	Missing
R	Replacement Ordered

- Ability to escape screen report when desired.

### LINK/UNLINK TOOLS TO TOOL BOX

- Enter badge number. Press F2 to scan employee file if badge number is unknown (file ordered by last name).
- Displays tools already linked to the tool box and the status of each tool in a screen like the one below.

ENTER CODE TO LINK TOOL TO TOOL BOX FOR EMPLOYEE <u>MAYES, VR</u>						
<u>LINK</u>	<u>QTY</u>	<u>TOOL#</u>	<u>STOCK#</u>	<u>DESCRIPTION</u>	<u>TOOLCOST</u>	<u>CATEGORY</u>
X	1	005	52352	Drill, 3/4" power	90.00	Drill
M	1	006	12352	Drill, 1/4" power	90.00	Drill
X	2	008	12351	Screw, Flat	2.00	Screw

PRESS F3 FOR A LIST OF ALL TOOLS IN THE DATABASE.  
 PRESS F4 FOR A LIST OF ALL VALID INVENTORY CODES.  
 PRESS F5 TO ASSIGN I-NUMBER TO TOOL.

- F3=Overlays this screen with another screen showing all available tools. Tools already linked will be marked by their inventory code. User selects the tool to link by highlighting the appropriate tool and entering its inventory code. May have more than one of the same tool in the tool box, therefore, user may enter a quantity. If a quantity is not entered, the default will be 1.
- F4=Overlays this screen with another screen showing all valid inventory codes and the code descriptions.
- F5=Overlays with a screen allowing user to enter an I-number for the currently highlighted tool (also shows badge number and tool number).

### SWITCH AND COPY TOOL BOXES

- This option allows the user to change the ownership of a complete tool box without reentering all data. The user can also copy the contents from one tool box to another tool box to save time while building the database.

- SWITCH OWNERSHIP OF TOOL BOX(S) OR COPY CONTENTS OF TOOL BOX(C)? \_\_\_\_\_  
(Enter desired option or leave blank to return to main menu.)
- ENTER BADGE NUMBER OF TOOL BOX TO SWITCH OR COPY FROM> \_\_\_\_\_
- ENTER BADGE NUMBER OF TOOL BOX TO SWITCH OR COPY TO> \_\_\_\_\_
- The computer will use the link file to switch or copy the source tool box contents to the target tool box.

## **INVENTORY**

### **INVENTORY MENU**

1. INITIAL SETUP OF INVENTORY SCHEDULE
2. PRINT INVENTORY SCHEDULE
3. INVENTORY SHEETS
4. RECORD INVENTORY TO COMPUTER
5. RETURN TO MAIN MENU

### **1. INITIAL SETUP OF INVENTORY SCHEDULE**

- Computer automatically sets up an inventory schedule picking 4 tool boxes per week (Mon, Tue, Wed, Thur) starting with the date the user enters and excluding holidays. The tool box inventory is spread by organization code. For example, Monday schedules someone from EM7 and Tuesday schedules someone from ES4. Process is repeated until all tool boxes have an inventory schedule.

### **2. PRINT INVENTORY SCHEDULE**

- REPORT ON: SPECIFIC TOOL BOX  
ENTER BADGE NUMBER> \_\_\_\_\_  
SPECIFIC TIME FRAME  
ENTER DATES> \_\_\_/\_\_\_/\_\_\_ TO \_\_\_/\_\_\_/\_\_\_  
SPECIFIC ORGANIZATION  
ENTER ORG CODE> \_\_\_\_\_

(Place a value in a blank above to report on just one employee, a particular time period, or a specific organization. Otherwise receive the entire inventory schedule.)

- SORT BY: NEXT INVENTORY DATE (D) \_\_\_\_\_  
ORGANIZATION (O) \_\_\_\_\_

(Place a value beside the sort order desired. Otherwise receive printout by date.)

- SEND OUTPUT TO SCREEN OR PRINTER

(If sent to screen, still have option of printing to printer afterwards.)

- Report will look like the following:

<u>INVENTORY DATE</u>	<u>NAME</u>	<u>BADGE</u>	<u>ORG</u>	<u>CFT</u>
07/15/93	Smith, RH	09003	EM7	PF
07/06/93	Jackson, LL	55055	ES4	IT

- Ability to escape screen report when desired.

### 3. INVENTORY SHEETS

- This will be a hard copy printout.
- REPORT ON: SPECIFIC BADGE NUMBER  
ENTER BADGE NUMBER> \_\_\_\_\_  
SPECIFIC ORGANIZATION  
ENTER ORG CODE> \_\_\_\_\_

(Place a value in a blank above to report on just one employee or one organization. Otherwise get a sheet for everyone in the database.)

- Sort by tool number (default sort key).
- SEND OUTPUT TO SCREEN OR PRINTER  
(IF sent to screen, still have option of printing to printer afterwards.)
- Report will look like the inventory sheet on page 19.

The sheet will list all tools linked to the employee plus all tools which are linked to that employee's craft.

Three inventory periods will be recorded.

- Ability to escape screen report when desired.

### 4. RECORD INVENTORY TO COMPUTER

- Enter badge number. If badge number not known, press F2 to scan employee file (file order by last name).
- Enter date inventory was taken. From this, the next inventory date is calculated by adding 365 days to the inputted inventory date. Weekends, Fridays, and holidays are excluded. The computer must validate all dates.
- Enter supervisor name.
- Records three inventory periods.
- Displays a screen like the one below. Lists all the tools available to the craft or linked to the tool box. Enter inventory code to link a tool. Computer validates the code. There may be more than one of the same tool in a tool box, so user may enter a quantity. If a quantity is not entered, the default will be 1. User may enter notes if desired.

ENTER CODE TO LINK TOOL TO TOOL BOX FOR EMPLOYEE MAYES, VR

<u>LINK</u>	<u>QTY</u>	<u>TOOL#</u>	<u>STOCK#</u>	<u>DESCRIPTION</u>	<u>TOOLCOST</u>	<u>CATEGORY</u>	<u>INVNOTES</u>
X	1	005	52352	Drill, 3/4" power	90.00	Drill	
M	1	006	12352	Drill, 1/4" power	90.00	Drill	missing 5/4/93
X	2	008	12351	Screw, Flat	2.00	Screw	

PRESS F3 FOR A LIST OF ALL TOOLS IN THE DATABASE.  
PRESS F4 FOR A LIST OF ALL VALID INVENTORY CODES.

- F3=Overlays this screen with another screen showing all tools. Tools already linked are marked by their inventory code. User selects the tool to link by highlighting the appropriate tool and entering its code. CTRL+W to exit and save.
- F4=Screen showing all valid inventory codes and the code descriptions. Press ESC to exit.

## REPORTS

### REPORT MENU

1. EMPLOYEE REPORT
2. TOOLS LISTING
3. CODES LISTING
4. COST REPORT
5. TOOL BOX REPORT
6. TOOL BOX REPORT FOR INVENTORY
7. INVENTORY REPORTS
8. RETURN TO MAIN MENU

### 1. EMPLOYEE REPORT

- REPORT ON: SPECIFIC ORGANIZATION  
ENTER ORG CODE> \_\_\_\_\_  
SPECIFIC EMPLOYEE  
ENTER BADGE NUMBER> \_\_\_\_\_  
(OR PRESS F2 TO SCAN EMPLOYEE FILE)

(Place a value in a blank above to report on just one organization or just one employee. Otherwise report on all employees in the database.)

- SORT BY: NAME (N) \_\_\_\_\_  
BADGE NUMBER (B) \_\_\_\_\_

(Place a value beside the sort order desired. Otherwise order will be by name.)

- SEND OUTPUT TO SCREEN OR PRINTER

(If sent to screen, still have option of printing to printer afterwards.)

- Report will look like the following:

<u>BADGE#</u>	<u>NAME</u>	<u>CFT</u>	<u>ORG</u>	<u>LAST INV</u>	<u>NEXT INV</u>
12777	Mayes, VR	PF	EM7	03/15/93	03/14/94
12778	Baker, JR	EL	EM7	03/16/93	03/15/94
12789	Hampton, SK	PF	ES4	03/19/93	03/18/94

- Ability to escape screen report when desired.

## 2. TOOLS LISTING

- REPORT ON: SPECIFIC TOOL

ENTER TOOL NUMBER> \_\_\_\_\_

OR

ENTER STOCK NUMBER> \_\_\_\_\_

SPECIFIC ORGANIZATION

ENTER ORG CODE> \_\_\_\_\_

SPECIFIC TOOL BOX

ENTER BADGE NUMBER> \_\_\_\_\_

SPECIFIC CRAFT

ENTER CRAFT CODE> \_\_\_\_\_

SPECIFIC INVENTORY CODE

ENTER INVENTORY CODE> \_\_\_\_\_

(Place a value in a blank above to report on a specific tool. tools for just one organization, tools that a specific employee has, tools for a specific craft, or tools with a specific inventory code. Otherwise receive all tools.)

- SORT BY: TOOL NUMBER (T) \_\_\_\_\_  
STOCK NUMBER (S) \_\_\_\_\_  
TOOL DESCRIPTION (D) \_\_\_\_\_

(Place a value beside the sort order desired. Otherwise order will be by description.)

- SEND OUTPUT TO SCREEN OR PRINTER

(If sent to screen, still have option of printing to printer afterwards.)

- Report will look like the following:

<u>TOOL#</u>	<u>STOCK#</u>	<u>DESCRIPTION</u>	<u>QTY</u>	<u>COST</u>	<u>TOTAL COST</u>
001	555	Power Drill	10	90.00	900.00

- Ability to escape screen report when desired.

## 3. CODES REPORT

- SORT BY: INVENTORY CODE (C) \_\_\_\_\_  
INVENTORY DESCRIPTION (D) \_\_\_\_\_

(Place a value beside the sort order desired. Otherwise order will be by code.)

- SEND OUTPUT TO SCREEN OR PRINTER  
(If sent to screen, still have option of printing to printer afterwards.)

- Report will look like the following:

<u>INVENTORY CODE</u>	<u>CODE DESCRIPTION</u>
X	Accounted for
M	Missing
R	Replacement ordered

- Ability to escape screen report when desired.

#### 4. COST REPORT

- REPORT ON: SPECIFIC TOOL BOX  
ENTER BADGE NUMBER> \_\_\_\_\_  
SPECIFIC ORGANIZATION  
ENTER ORG CODE> \_\_\_\_\_  
SPECIFIC TOOL  
ENTER TOOL NUMBER> \_\_\_\_\_

(Place a value in blank above to report on just one tool box, one organization, or one tool. Otherwise receive report on entire tools database.)

- INCLUDE DETAILED RECORDS? Y/N \_\_\_\_\_
- SEND OUTPUT TO SCREEN OR PRINTER  
(If sent to screen, still have option of printing to printer afterwards.)
- Report will look like the following:

Without details:

TOOL BOX XXXXXX FOR A TOTAL COST OF \$9999.99

ORG CODE XXXXXX FOR A TOTAL COST OF \$9999.99

TOOL XXXXXX FOR A TOTAL COST OF \$9999.99

ENTIRE DATABASE FOR A TOTAL COST OF \$9999.99

With details:

FOR TOOL BOX = XXXXXX (NAME)

<u>TOOL#</u>	<u>STOCK#</u>	<u>DESCRIPTION</u>	<u>COST</u>	<u>QTY</u>	<u>TOTAL COST</u>
001	123512	Drill	90.00	1	\$ 90.00
005	251235	Wrench	5.00	2	\$ 10.00
TOTAL =					\$ <u>95.00</u>

FOR ORG CODE = XXXXXX

<u>TOOL#</u>	<u>STOCK#</u>	<u>DESCRIPTION</u>	<u>COST</u>	<u>BADGE</u>	<u>NAME</u>	<u>CODE</u>
001	123512	Drill	90.00	12812	Smith, RH	X
				12352	Hall, KK	X

TOTAL COST = \$ 180.00 TOTAL QTY = 2

FOR TOOL = XXXXXX

STOCK = XXXXXXXXXXXXXXXXXX

DESC = XXXXXXXXXXXXXXXXXXXXXXXXXXXXXXXXXXXX

<u>BADGE</u>	<u>NAME</u>	<u>ORG</u>	<u>CODE</u>	<u>QTY</u>	<u>COST</u>	<u>TOTAL COST</u>
55555	Jays, JD	EM7	X	1	15.00	\$ 15.00
91235	Tipps, GD	EM7	X	2	15.00	\$ 30.00
12351	Welling, RA	ES4	X	1	15.00	\$ 15.00
TOTAL COST = \$ <u>60.00</u>						TOTAL QTY = <u>4</u>

- Ability to escape screen report when desired.

### 5. TOOL BOX REPORT

- REPORT ON: SPECIFIC EMPLOYEE  
ENTER BADGE NUMBER> \_\_\_\_\_

(Place a value in a blank above to report on just one employee. Otherwise get report of all tool boxes.)

- Sort by description of tool (default sort key).
- SEND OUTPUT TO SCREEN OR PRINTER  
(If sent to screen, still have option of printing to printer afterwards.)
- Report will look like the following:

FOR TOOL BOX = 12777

NAME: Mayes, VR		ORG: EM7	CFT: PF				
<u>TOOL#</u>	<u>STOCK#</u>	<u>DESCRIPTION</u>	<u>QTY</u>	<u>COST</u>	<u>TOTAL COST</u>	<u>INVCODE</u>	
001	123512	Drill	1	90.00	\$ 90.00	X	
005	251235	Wrench	2	10.00	\$20.00	X	
006	12352	Power Drill, 1/4"	1	100.00	\$100.00	M	

- Ability to escape screen report when desired.

### 6. TOOL BOX REPORT FOR INVENTORY

- REPORT ON: SPECIFIC EMPLOYEE  
ENTER BADGE NUMBER> \_\_\_\_\_  
SPECIFIC ORGANIZATION  
ENTER ORG CODE> \_\_\_\_\_

(Place a value in a blank above to report on just one employee or one organization. Otherwise get a report of all tool boxes.)

- Sort by tool number (default sort key).
- SEND OUTPUT TO SCREEN OR PRINTER  
(If sent to screen, still have option of printing to printer afterwards.)
- Report will look like the inventory sheet on page 19.

The sheet will list all tools linked to the employee plus all tools which are linked to that employee's craft. The sheet will record up to three inventory periods.

- Ability to escape screen report when desired.

## 7. INVENTORY SCHEDULE REPORT

- REPORT ON: SPECIFIC TOOL BOX  
ENTER BADGE NUMBER> \_\_\_\_\_  
SPECIFIC TIME FRAME  
ENTER DATES> \_\_/\_\_/\_\_ TO \_\_/\_\_/\_\_  
SPECIFIC ORGANIZATION  
ENTER ORG CODE> \_\_\_\_\_

(Place a value in a blank above to report on just one employee, a particular time period, or a specific organization. Otherwise receive entire inventory schedule.)

- SORT BY: NEXT INVENTORY DATE (D) \_\_\_\_\_  
ORGANIZATION (O) \_\_\_\_\_

(Place a value beside the sort order desired. Otherwise receive printout by date.)

- SEND OUTPUT TO SCREEN OR PRINTER

(If sent to screen, still have option of printing to printer afterwards.)

- Report will look like the following:

<u>INVENTORY DATE</u>	<u>NAME</u>	<u>BADGE</u>	<u>ORG</u>	<u>CFT</u>
07/15/93	Smith, RH	09003	EM7	PF
07/16/93	Jackson, LL	55505	ES4	IT

- Ability to escape screen report when desired.

### ACCESS CRAFT FILE

#### CRAFT FILE MENU

1. ADD/EDIT CRAFT FILE
2. DELETE FROM CRAFT FILE
3. CRAFT REPORT
4. RETURN TO MAIN MENU

#### 1. ADD/EDIT CRAFT FILE

CRAFT CODE: \_\_\_\_\_  
CRAFT DESCRIPTION: \_\_\_\_\_

- Enter craft code to retrieve record. If craft code does not exist, a new record is created.
- If craft code not known, press F2 to scan craft file (file ordered by code). Highlight record and hit ESC to return with record selected.
- If craft code changes, the corresponding craft code in EMPLOYEE, CFTLIST, and TEMPCFT files is also

changed. User must confirm that the code is being changed.

- Cannot have duplicate craft codes.

## 2. DELETE FROM CRAFT FILE

- Enter craft code to retrieve record (same screen as ADD/EDIT CRAFT FILE). Press F2 to scan list.
- User must confirm before actually deleting record.
- Cannot delete a craft code if there are badges and tools linked to it. (Must unlink first.)

## 3. CRAFT REPORT

- REPORT ON: SPECIFIC CRAFT CODE  
ENTER CRAFT CODE> \_\_\_\_\_  
(OR PRESS F2 TO SCAN CRAFT FILE)

(Place a value in blank above to report on just one craft code. Otherwise report on all craft codes in the database.)

- SORT BY: CRAFT CODE (C) \_\_\_\_\_  
CRAFT DESCRIPTION (D) \_\_\_\_\_

(Place a value beside sort order desired. Otherwise order will be by code.)

- SEND OUTPUT TO SCREEN OR PRINTER  
(If sent to screen, still have option of printing to printer afterwards.)
- Report will look like the following:

<u>CRAFT CODE</u>	<u>CRAFT DESCRIPTION</u>
BM	Boilermaker
EL	Electrician
PF	Pipe fitter

- Ability to escape screen report when desired.

## FILE STRUCTURE

- These are the main databases, their field names, data types, widths, and descriptions of their contents.
- Keys are in italics.

### DATABASE NAME

#### 1. EMPLOYEE (table of all employees)

<i>badgenum</i>	C	5	Employee Badge Number
<i>lastname</i>	C	15	Employee Last Name
<i>initials</i>	C	2	Employee Initials
<i>cftcode</i>	C	2	Employee Craft Code
<i>orgcode</i>	C	5	Employee Organization Code
<i>nextinv</i>	D	8	Next Inventory Date
<i>period1</i>	D	8	Period one Inventory Date
<i>period2</i>	D	8	Period two Inventory Date
<i>period3</i>	D	8	Period three Inventory Date
<i>supv1</i>	C	10	Supv for Inventory Period one
<i>supv2</i>	C	10	Supv for Inventory Period two
<i>supv3</i>	C	10	Supv for Inventory Period three

#### 2. TOOLS (table of all tools)

<i>toolnum</i>	C	5	Tool Number
<i>stocknum</i>	C	18	Stock Class + Stock Number
<i>category</i>	C	10	Tool Category
<i>desc1</i>	C	70	Line one Tool Description
<i>desc2</i>	C	70	Line two Tool Description
<i>toolcost</i>	N	9.2	Cost of Tool (Max 999,999.99)

#### 3. LINK (table which links employee tool box to specific tool)

<i>badgenum</i>	C	5	Employee Badge Number
<i>toolnum</i>	C	5	Tool Number
<i>invcode</i>	C	2	Inventory Code
<i>invnotes</i>	C	50	Inventory Notes
<i>qty</i>	N	4	Qty of one Tool in one Tool Box

#### 4. CODES (table of valid inventory codes and descriptions)

<i>invcode</i>	C	2	Inventory Code
<i>invdesc</i>	C	20	Inventory Code Description

#### 5. CFTLIST (table of valid tools for specific craft)

<i>toolnum</i>	C	5	Tool Number
<i>cftcode</i>	C	2	Craft Code

#### 6. HISTORY (table of all history items: what's added, subtracted, lost, etc)

<i>toolnum</i>	C	5	Tool Number
<i>badgenum</i>	C	5	Employee Badge Number
<i>invcode</i>	C	2	Inventory Code
<i>invnotes</i>	C	50	Inventory Notes
<i>invdate</i>	D	8	Inventory Date

#### 7. CRAFT (table of the valid craft codes)

<i>cftcode</i>	C	2	Craft Code
<i>cftdesc</i>	C	15	Craft Description

# FILE STRUCTURE -- HOW EVERYTHING FITS TOGETHER

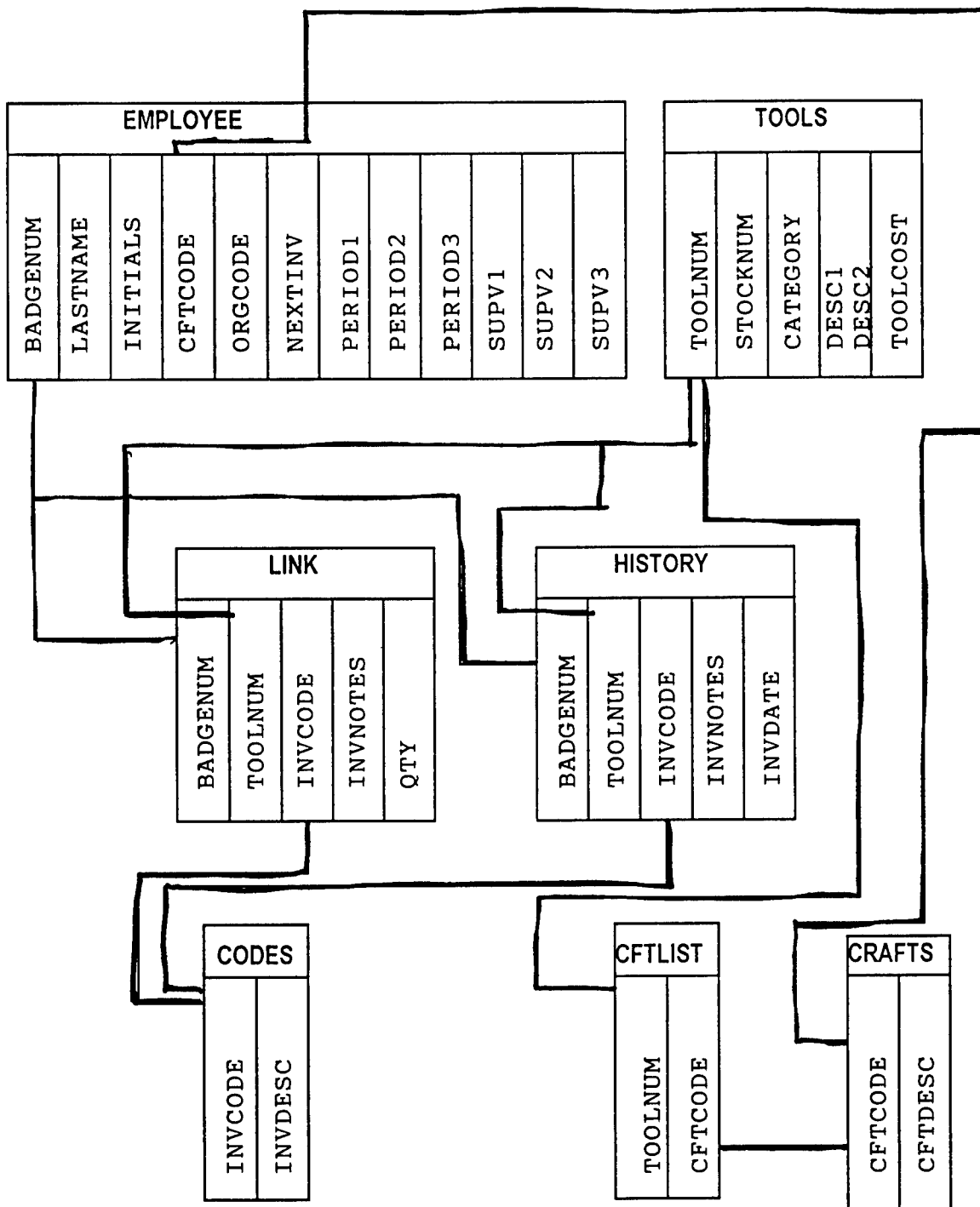

T O O L K I T I N V E N T O R Y S H E E T

BADGE#: 14375  
NAME: RIDDLE, CD

< INVENTORY KEY CODES >  
(X) TOOL ACCOUNTED FOR IN KIT  
(M) TOOL MISSING  
(S) REPLACED FROM LOCAL STOCK  
(R) REPLACEMENT TOOL ORDERED  
(\* ) SET INCOMPLETE, SEE NOTE

INVENTORY DATE & RECORDER NAME FOR INVENTORY PERIOD:

(SUPV SIGN) (CFT SIGN)

1. 02/28/91 \_\_\_\_\_
2. 03/02/92 \_\_\_\_\_
3. 03/02/93 \_\_\_\_\_

ITEM NUMBER	TOOL NUMBER	STOCK NUMBER	DESCRIPTION	INVENTORY PERIOD		
				1	2	3
1	99	346650932	PHILLIPS HEAD SCREW DRIVER	R	X	X
2	101	814011201	TAPE MEASURER, 25 FT	M	X	X
3	300	247094567	POWER DRILL WITH 110 VOLT REQUIREMENT	X	X	X
4	355	3676027708	POWER SAW WITH 6 FT CORD	X	X	X
5	600	6345088420	WRENCH	X	X	S
6	800	136509200	HAMMER	X	M	X
7	2100	35778987	SCREW, FLAT	X	X	X

NOTES FOR INVENTORY PERIOD:

1. \_\_\_\_\_
2. \_\_\_\_\_
3. \_\_\_\_\_

COMPARISON OF ATOMIC ABSORPTION AND  
ICP ATOMIC EMISSION SPECTROMETERS

Kathy Waterman

Mentors:

Steve Any                  Jim Brown  
The Bionetics Corporation

Final Report for:

AFOSR Summer Research Program  
High School Apprentice Program  
Arnold Engineering Development Center  
Arnold Air Force Base

August 1993

COMPARISON OF ATOMIC ABSORPTION AND  
ICP ATOMIC EMISSION SPECTROMETERS

Kathy Waterman  
High School Apprentice  
Arnold Engineering Development Center  
Arnold Air Force Base

Abstract

Spectroscopy is the study of the interaction of electromagnetic radiation with matter. Spectroscopic instrumentation separates electromagnetic radiation into its component wavelengths which enables one to measure the intensity or strength of the radiation at each wavelength. This intensity can then be calculated into concentration. The chemistry lab at Arnold Engineering Development Center (AEDC) uses both atomic absorption spectrophotometry with atomic emission spectroscopy for analysis. The personnel at AEDC were unsure of the correlation between results from the instruments due to a previous comparison which found they did not yield corresponding results for some elements. However, the instruments had not been rigorously calibrated or standardized during this testing period. This project was designed to reveal if the instruments could produce accurate and precise results for a known sample when properly calibrated and standardized.

The ICP and AA did yield comparable results on metals in water when properly calibrated and standardized. Further investigation could reveal which instrument has the better sensitivity and repeatability for each element, and this information could be used to determine which instrument has the best performance for each element.

# COMPARISON OF ATOMIC ABSORPTION AND ICP ATOMIC EMISSION SPECTROMETERS

Kathy Waterman

## Introduction

Spectroscopy is the study of the interaction of electromagnetic radiation with matter. Spectroscopic instrumentation separates electromagnetic radiation into its component wavelengths which enables one to measure the intensity or strength of the radiation at each wavelength. Instruments which use the emission procedure are called spectroscopes or spectrographs. Instruments which measure by absorption are called spectrophotometers.

Atomic absorption spectrophotometry {AA} is a method which can determine the concentrations of metallic elements in a solution of an organic or inorganic material. A hollow-cathode light source which contains the element to be tested emits the light spectrum of that element. A flame composed of nitrous oxide/air or acetylene/air is employed to generate enough heat to decompose the sample into its constituent atoms. When the radiation is passed through a vapor containing ground-state atoms of that element, the atoms absorb at characteristic wavelengths. The instrumentation measures the degree of absorption photoelectrically and transforms this degree into an estimation of the amount {or concentration} of the element within the sample.

Atomic emission analysis follows the same principles as atomic absorption; however, the sample is heated and decomposed using an argon plasma in lieu of a flame. This plasma allows the Inductively Coupled Plasma {ICP} to reach temperatures of 10 000 degrees Kelvin versus the 2 000 to 3 000 degrees Celsius which is possible with the flame. The higher temperatures theoretically remove any foreign chemical interferences.

The chemistry lab at Arnold Engineering Development Center {AEDC} utilizes both of these methods for analysis. The personnel at AEDC were unsure of the correlation between these instruments due to a previous comparison which found they did not yield corresponding results for some elements. However, the instruments had not been rigorously calibrated or standardized during this testing period. This project was designed to reveal if the instruments could produce accurate and precise results for a known sample when properly calibrated and standardized.

#### Methodology

Two samples were selected to be used for testing. These samples had published data concerning concentrations of certain metals which was necessary to calculate the accuracy of each machine. These samples were named 2C9949 and EPA 010. Both were used to test the ability of the lab to correctly measure the concentrations of these metals and to ensure the personnel are following an appropriate procedure. For this project, hydrochloric and nitric acids were added to the samples to hold the elements in solution. These

samples are packaged highly concentrated; therefore, they must be diluted to the specified volumes which contain the appropriate concentration. The metals which were tested in this project were aluminum, barium, beryllium, cadmium, chromium, copper, iron, lead, manganese, nickel, and silver.

For testing on the ICP, standards composed of one percent nitric acid and five percent hydrochloric acid were made. Silver, barium, cadmium, chromium, and lead were combined in one standard of one part-per-million (ppm) concentration. Copper, iron, manganese, and nickel had a two ppm standard. Aluminum and beryllium each had their own standard of two ppm. The standards and their concentrations were chosen to represent the amount present in the sample. When testing on the ICP, each element must be tested separately, and one standard and a blank must be run every time to create a calibration curve. The instrument must also have a proper nebulizer setting for the specific element being tested to maximize recovery. Some elements required different standards to be made because the concentrations of the first ones were not appropriate and did not yield usable curves. After many attempts to fulfill the criteria for certain elements, it was decided that the instrument was unable to measure concentrations of certain elements accurately. The instrument never found the proper concentrations of beryllium and manganese.

On the AA, standards composed of one percent nitric acid and five percent hydrochloric acid were also made. However, the AA requires three standards and a blank per element to create the most accurate calibration curve. A maximum concentration for which the curve of each element will remain linear was employed as the highest standard. The other two were the best numbers to retain fairly close divisions of one-third. In addition, some

of the elements tested required the addition of sufficient alkali {cesium was used} to control ionization. Each lamp had to be correctly positioned which was the result of carefully "tweaking" the instrument. The known correct absorbance for the largest standard was used to manipulate the instrument to obtain the best possible absorbance. During the testing procedure, it was discovered that the instrumentation lacked sensitivity to obtain sufficient absorbance for some metals with very low concentrations. These metals were barium, nickel, and lead.

### Results

After testing was completed, the results were compared to observe whether the instruments could return comparable data. The data was studied for accuracy and precision {see attached graphs}. Because of both instruments lack of sensitivity on certain metal and because of the sample lacked some of the metals, a complete study could be performed on only five of the eleven elements tested. These elements were aluminum, cadmium, chromium, copper, and iron.

The comparison revealed that the machines did correlate with answers within +5% to -5% of the actual value for each element. For this type of testing and these very small concentrations, this return was well within accuracy specifications. When comparing the precision or repeatability of the instruments, it was discovered that the instruments were fairly precise in their return. Only chromium on the AA was questionable with an eight percent relative difference. However, the ICP was very dependable with chromium with

only a one percent difference. Using this information, it would be safe to assume that the ICP is a better instrument with which to test for chromium. However, further testing is necessary to verify this discovery.

### Conclusions

The ICP and AA did yield comparable results on metals in water when properly calibrated and standardized. Further investigation could reveal which instrument has the improved sensitivity and precision for each element, and this information could be used to determine which instrument has the best performance for each element, thus having the best overall return. Since the chemistry lab has many orders which they have to have done by a certain date and highly sophisticated instrumentation may take days to repair even if the smallest thing occurs, this information concerning the correlation between these instruments will allow the chemistry lab personnel to better use them as back-ups for each other.

### Acknowledgments

The opportunity that I have had for the last two years to work at the chemistry lab at AEDC has been wonderful. Not only have I been given the chance to understand more about chemistry and what a profession in this career entails, but I have also gotten to know some very interesting, highly intelligent, and extremely nice people. I would really like to thank the Air Force Office of Scientific Research for having this program. It is a unique

opportunity for high school students to observe a possible career for six weeks and see what really occurs. The other apprentices and I have experienced within a summer a profession which takes years of schooling to learn, and this type of learning is a change from school books and lectures: It is real life. I would also like to thank RDL for keeping this program organized and paying me on time. At AEDC, there are many who deserves my gratitude. Mr. James Mitchell did a fantastic job of organizing the program here. He was suddenly given this huge responsibility to manage ten high school kids and keep them busy all summer. You did great, James!!! Most importantly from my summer, I would like to thank everyone who works at the Chem/Met Lab at AEDC. I feel even more comfortable this summer than last. For forty hours a week, we slaved over hot instruments together and comforted each other when they began to act up {they always did}. Even when you all told me hours upon hours of Auburn jokes, I loved every minute of it because I wasn't the little high school student, I was a member of this unusual team. I will really miss you all next year. I will try to come back to visit. Thank you all for the summer job I will never forget!!!!!!!!!!

# ACCURACY FOR ICP VS. AA

PERCENT DEVIATION FROM TRUE VALUE

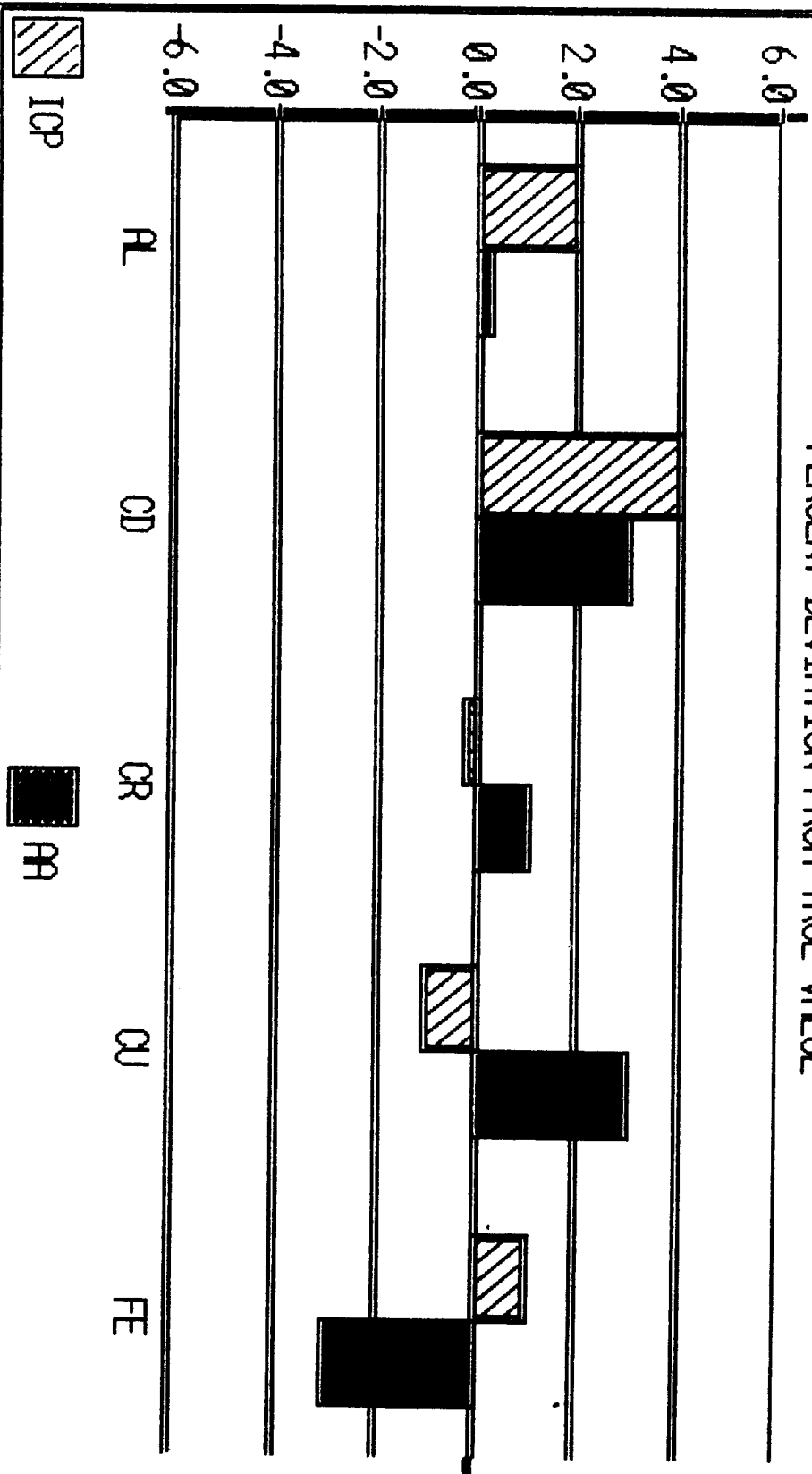

# PRECISION FOR ICP VS. AA

RELATIVE PERCENT DIFFERENCE

