

REPORT DOCUMENTATION PA

d
1-0188

AFRL-SR-BL-TR-98-

0712

listing data sources
other aspect of this
GPO: 1975 Jefferson
20503.

Public reporting burden for this collection of information is estimated to average 1 hour per response, including the time for reviewing the collection of information, gathering and maintaining the data needed, and completing and reviewing the collection of information, including suggestions for reducing this burden, to Washington Headquarters, Suite 1204 Arlington, VA 22202-4302, and to the Office of Management and Budget, Paperwork Project, Washington, DC 20503.

1. AGENCY USE ONLY (Leave blank)		2. REPORT DATE		3. REPORT TYPE AND DATES COVERED	
				FINAL 01 Sep 97 - 31 Aug 98	
4. TITLE AND SUBTITLE				5. FUNDING NUMBERS	
STTR97 ELECTRO-OPTIC FIBER				F49620-97-C-0063	
6. AUTHOR(S)				STTR/TS	
DR DAVID WELKER				65502F	
7. PERFORMING ORGANIZATION NAME(S) AND ADDRESS(ES)				8. PERFORMING ORGANIZATION REPORT NUMBER	
SENTEL TECHNOLOGIES, L.L.C. BOX 41-1 NE 1615 EASTGATE BLVD. FULLMAN WA 99163					
9. SPONSORING / MONITORING AGENCY NAME(S) AND ADDRESS(ES)				10. SPONSORING MONITORING AGENCY REPORT NUMBER	
AFOSR/NL 801 RANDOLPH STREET SUITE 732 ARLINGTON VA 22203-1977					
DR CHARLES Y-C. LEE					
11. SUPPLEMENTARY NOTES					
12a. DISTRIBUTION / AVAILABILITY STATEMENT				12b. DISTRIBUTION CODE	
Approved for public release; classification unlimited.					
13. ABSTRACT (Maximum 200 words)					
<p>We have accomplished all of the Phase I technical objective set forth in the original proposal: We have demonstrated the process for making electrodes around the core of a single mode polymer optical fiber; we have demonstrated that the core can be electric field poled with these electrodes; we have determined the linear loss and guiding mode profiles of the poled cores; we have measured Phase modulation in this fiber with an external interferometer; we have shown that it is feasible to use such fibers to make a sagnac modulator and other electrooptic devices.</p>					
<p>19981120 184</p>					
14. SUBJECT TERMS				15. NUMBER OF PAGES	
				16. PRICE CODE	
17. SECURITY CLASSIFICATION OF REPORT (U)		18. SECURITY CLASSIFICATION OF THIS PAGE (U)		19. SECURITY CLASSIFICATION OF ABSTRACT (U)	
				20. LIMITATION OF ABSTRACT (UL)	

FINAL TECHNICAL REPORT
SEPTEMBER 1, 1997- AUGUST 31 1998

CONTRACT F49620-97-C-0063
STTR 97 ELECTRO-OPTIC FIBER

DAVID WELKER
SENTEL TECHNOLOGIES, L.L.C.
BOX 41-1
NE 1615 EASTGATE BLVD.
PULLMAN, WA 99163

BLANK PAGE

PROJECT FLOW CHART

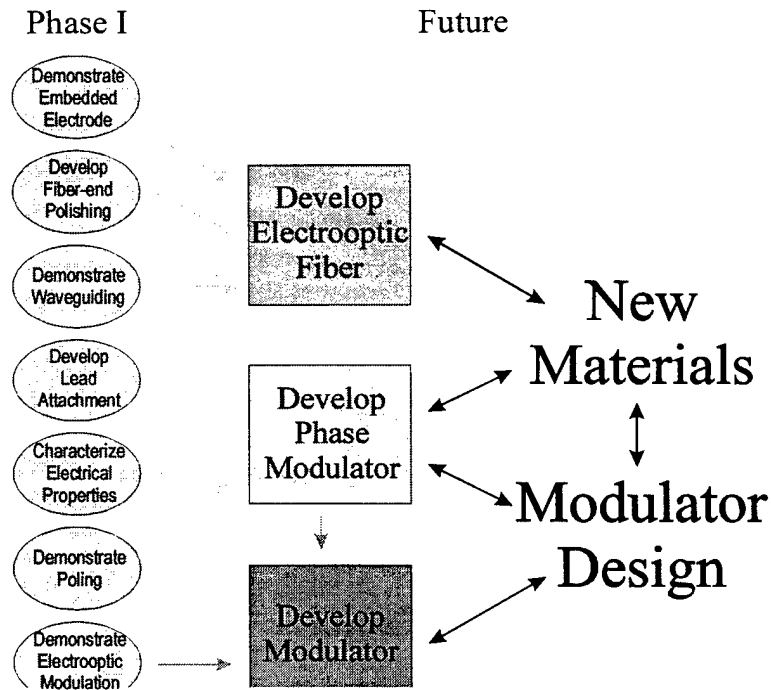

Figure 1. Project Flow Chart. Blue ellipses show Phase I results already demonstrated and boxes show ongoing research.

PHASE I OBJECTIVES AND RESULTS ACHIEVED

The results of Phase I research and its relationship to the our future research is best summarized by the flow chart shown in Figure 1.

1. ELECTROOPTIC FIBER

In Phase I, the three separate technical goals of demonstrating embedded electrodes, developing a fiber-end polishing process, and demonstrating waveguiding have been met. We will apply our well defined process from these three Phase I results to refine and improve the electrooptic fiber to make it commercial grade. Furthermore, new materials will be investigated in the fiber-making process with the goal of developing more robust systems (see Figure 1) Both poled and unpoled fibers will be commercialized. Targeted customers are R&D organizations in major industries (telco and datacom OEMs, for example) that develop products that use electrooptic fiber. Below, we briefly describe the process that we developed in Phase I that demonstrates our ability to make electrooptic fiber.

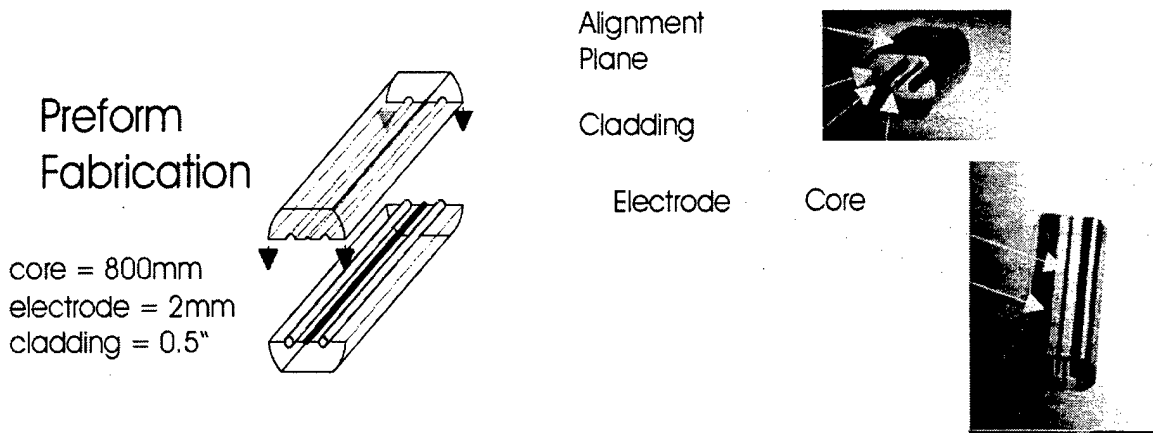

Figure 2. The preform fabrication process. Left: Schematic of process. Right: Photograph.

Figure 2 shows a schematic representation of how the preform is made. Two polymer half rounds are machined with three semicylindrical grooves to accept the dye doped polymer core (which itself is made by drawing a cylinder of dye-doped polymer) and the two electrodes. The two halves are sandwiched together and the assembly is squeezed together at elevated temperature. The right hand side of the figure shows two photographs of a small section of a typical preform. The flat upper and lower parts are used as an alignment plane. The use of the alignment plane is described later. We have further modified the alignment plane to the shape shown in Figure 3. This provides a polarity reference.

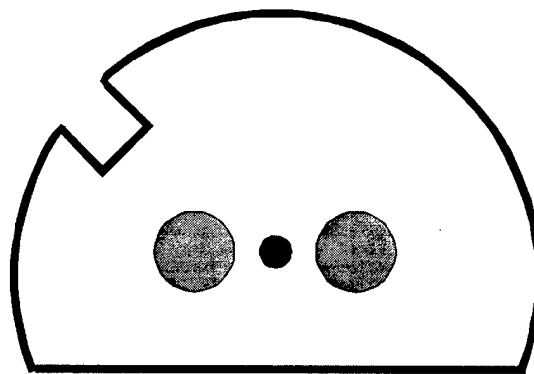

Figure 3. Modified Fiber shape

We have drawn such preforms into a fiber *while being poled*. This results in an electrooptic fiber. Note that typical poling voltages are 2 to 3 kV across a 40 μm gap and several hundred meters of poled fiber is drawn on a single spool. Higher voltages are possible, and, dielectric breakdown does not have catastrophic consequences. The poling occurs at the neck-down region of the draw, so if breakdown occurs in the softened part of the preform, the resistance greatly increases after the fiber leaves the heating zone and cools. Most of the several-hundred-meter fiber is thus usable. The details of the pooling process are described below.

The preform is pulled into a fiber in a drawing tower at about 230°C, which is above the glass transition temperature of the polymer and above the melting temperature of the indium. A high voltage power supply is attached to the electrode so that the dye-doped core can be poled during the drawing process. As the fiber leaves the drawing oven, it cools and the alignment of the chromophores is frozen in place. Figure 4 shows a schematic of the drawing tower. The preform is about 10cm in length and, for a fiber diameter of 125 μm, draws into about 1km of fiber.

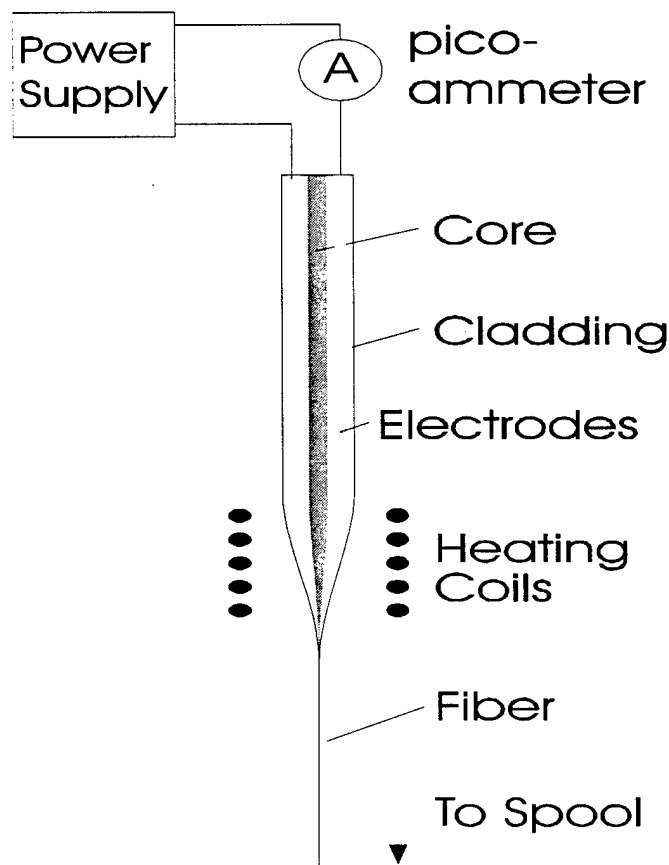

Figure 4. Drawing a fiber while poling with indium electrodes.

The current passing through the electrodes during poling is measured with an ammeter. A short during the poling process results in a spike in the current. Note that a large resistor(not shown), whose resistance is much lower than the resistance of the PMMA material that is being poled, is placed in series with the ammeter to prevent damage to the poling electronics.

The hottest point in the fiber is found to be in the neck-down region. Because ion mobility and free charge mobility increase when the polymer is heated, the measured current most likely passes between electrodes in the neck-down region. Similarly, the highest reorientational mobility of the dye chromophores is in the neck down region, so that it is also the region of highest degree of chromophore alignment. The neck-down region is thus the critical point in both fiber drawing and poling, and is the region monitored by the electronics.

Figure 5 shows a typical plot of the current as a function of time while an electrooptic fiber is drawn. This particular run illustrates the poling process. The total elapsed time corresponds to a fiber length of almost 1 km. When the fiber draw is started, a 1 kV voltage is applied across the electrodes. After about 100 s of drawing time, the voltage is increased to 2kV and the current approximately doubles. For 15 minutes, the current is approximately constant for a constant applied voltage, so the resistance in the neck-down region is approximately constant until 17 minutes into the draw. At that point, the current abruptly increases due to a short. Such a short can occur from an impurity in the neck-down region, dye aggregate, or imperfections in the preform. After the short is observed, the voltage is turned off and the fiber draw is allowed to continue for a few minutes before the voltage is turned on again. The measured current at 2kV is found to be about the same as it was just before the short. This is significant because it shows that a short along one part of a long fiber is not catastrophic to the remaining length of fiber. This observation can be understood as follows.

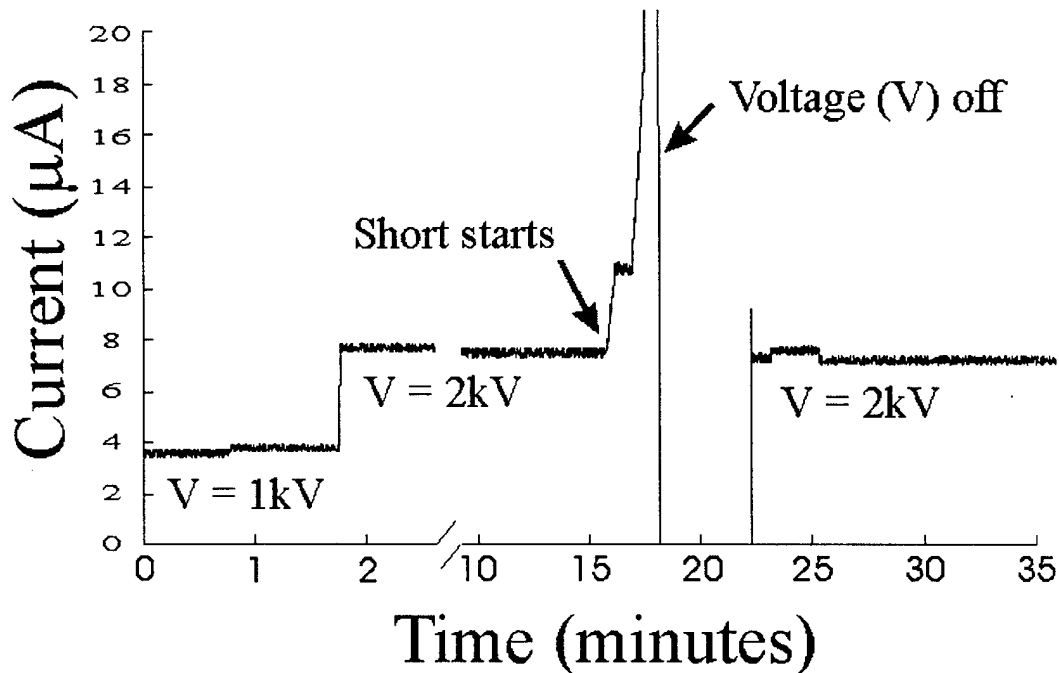

Figure 5. Current as a function of time.

The short most likely occurs at the neck-down region where the temperature is the highest. By turning off the poling field, the flow of the polymer at elevated temperature partially heals the short. When that region passes out of the heating zone, it cools, and the resistance increases. As the "shorted region" moves further away from the neck-down region, its effect on the total resistance also continues to go down. As a result, when the poling voltage is turned on, the material in the neck-down region is once again of high resistance, and the poling process continues similar to the pre-short conditions.

Once the fiber is pulled, it is cut into sections with a razor blade. We have developed a polishing technique using lapping paper to make the fiber ends smooth enough to couple light into the core. The fiber ends can be imaged with white light illumination or the guiding mode can be imaged. Figure 6 shows an enlarged false color image of the fiber end and a side view of a typical fiber. This fiber was made with a PMMA cladding, DR1/PMMA core and indium electrodes. The single mode core and electrodes are clearly visible in the side-view image. In the end view, the core is not visible in the photograph, but waveguiding has been observed (discussed later).

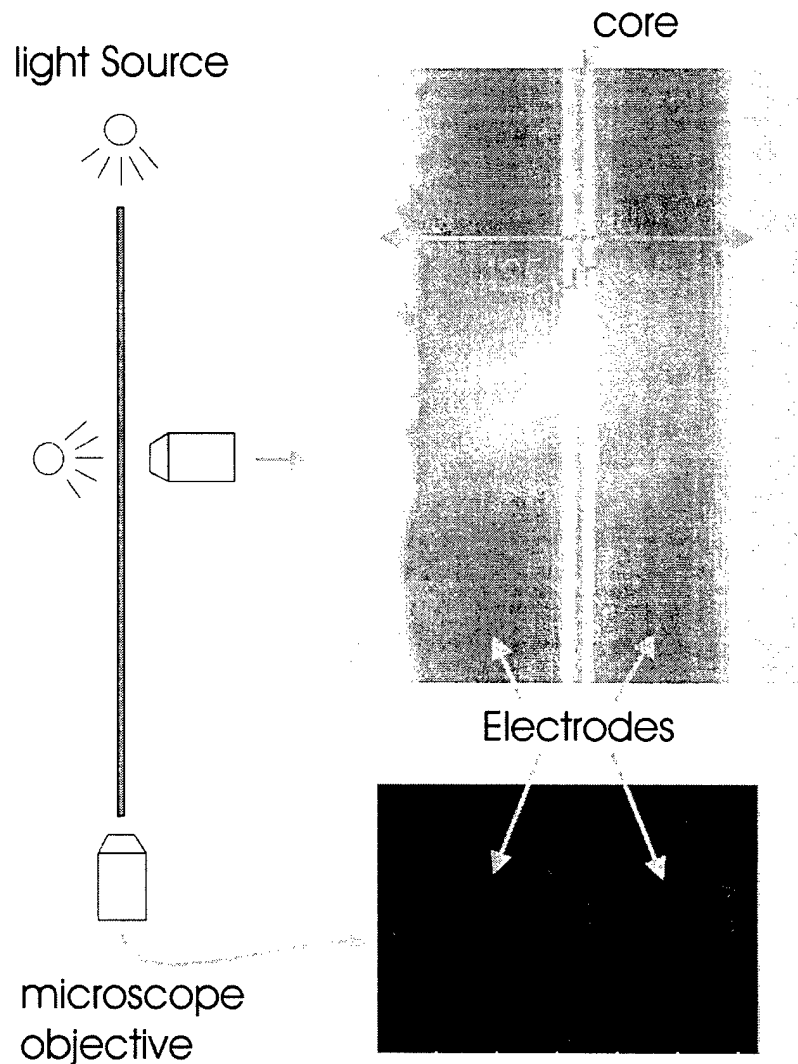

Figure 6. Fiber end and side view of an illuminated electrooptic fiber.

2. ELECTRODE ATTACHMENT

A typical device requires a propagation length on the order of 10cm. To be useful, a means for attaching leads to the electrodes must be developed. Figure 7a shows the processing steps that we have developed to make a device structure with attached leads. (1) The ends of the

fiber are polished with lapping paper and the fiber is attached to a substrate with epoxy. The alignment plane insures that the electrode pair is horizontal. (2) A notch is machined into the substrate up to the fiber surface. The fiber is then micro-machined under a microscope until one of the electrodes is exposed. Four such notches are prepared - two on either end of each electrode. (3) A bead of conducting epoxy is placed in each notch, a lead is inserted into the epoxy, and the epoxy is cured. The fiber's characteristics can now be evaluated. This device is an electrooptic phase modulator.

The electrical and optical properties of the device structure has been evaluated and shows that the resistance along each electrode is less than 1Ω and that the resistance between electrodes is $50,000M\Omega$ at room temperature and about $300 M\Omega$ during poling. We have also shown that this device structure supports single-mode waveguiding. Figure 7b shows the experiment with the phase modulator structure and a false color end-on view of a guided mode. Light is launched into the fiber core with a microscope objective. A second objective images the light onto a diode array and is displayed on a monitor. The electrodes and the guided mode in the core are visible. Note that the core profile is elliptical. We have found that varying the fiber drawing conditions such as the temperature and stress can control the shape of the core. Core shapes from circular cross sections to high ellipticity have been demonstrated. This control of shape allows us to make polarization-independent fiber for the circular case, or polarization-maintaining fiber in the highly elliptical case.

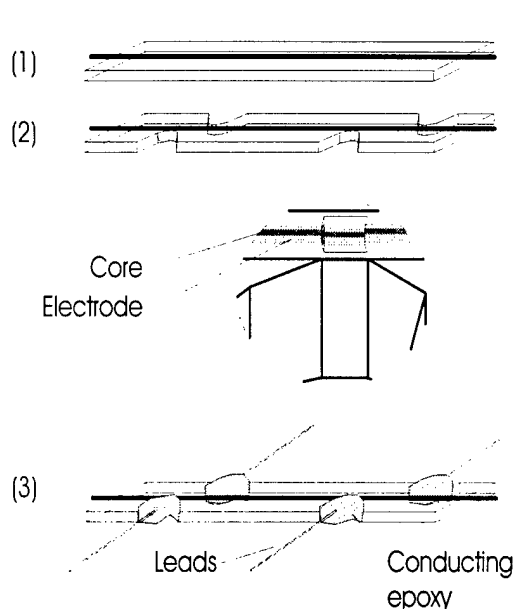

Figure 7a. Process for attaching leads.

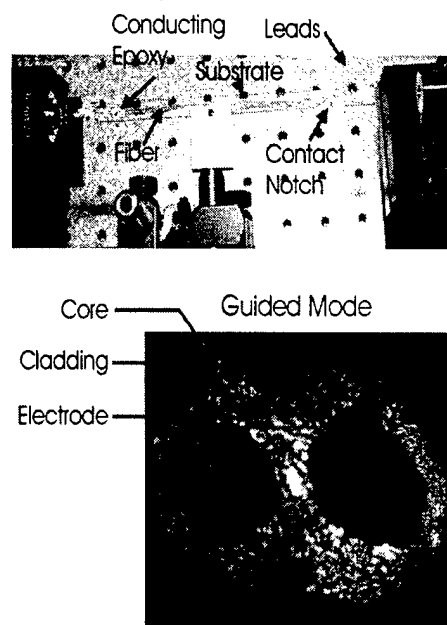

Figure 7b. Light coupling experiment and end-on view.

One method of evaluating the poling process is through thermally stimulated discharge (TSD). In these experiments, a poled polymer fiber is heated, and the current between the electrodes monitored. The magnitude of the current is related to the degree of reorientation of dipoles in the polymer. This experiment, then, quantifies the poling efficiency, that is, the degree of dipolar orientation. Figure 8 shows the current as a function of time after the device structure is heated. The total charge collected (a time integral over the current) is consistent with the amount of orientation that we would expect from the poling field of 0.5MV/cm.

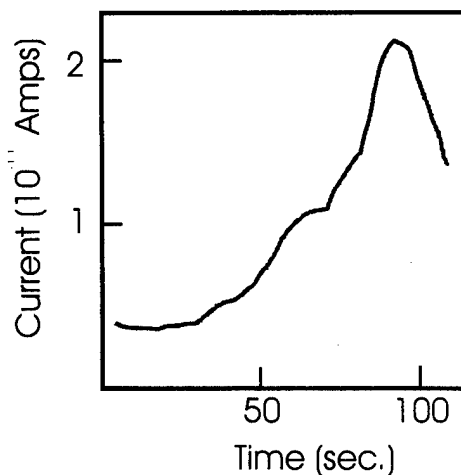

Figure 8. Thermally simulated discharge current measure in a poled EO fiber.

3. ELECTROOPTIC MODULATOR

The third technical objective is to demonstrate an electrooptic modulator. The phase modulator, described above, has been built into an intensity modulator. In Phase I research, we have demonstrated electrooptic modulation in an external Mach-Zehnder interferometer. The phase modulator is placed in one arm of the interferometer and a sinusoidal modulating voltage is applied. The light is detected with a silicon or Germanium detector and sent to a computer-controlled lockin-amplifier, which is used to measure the magnitude of the signal at the applied voltage frequency. Details of our phase modulation demonstration are described in the next section.

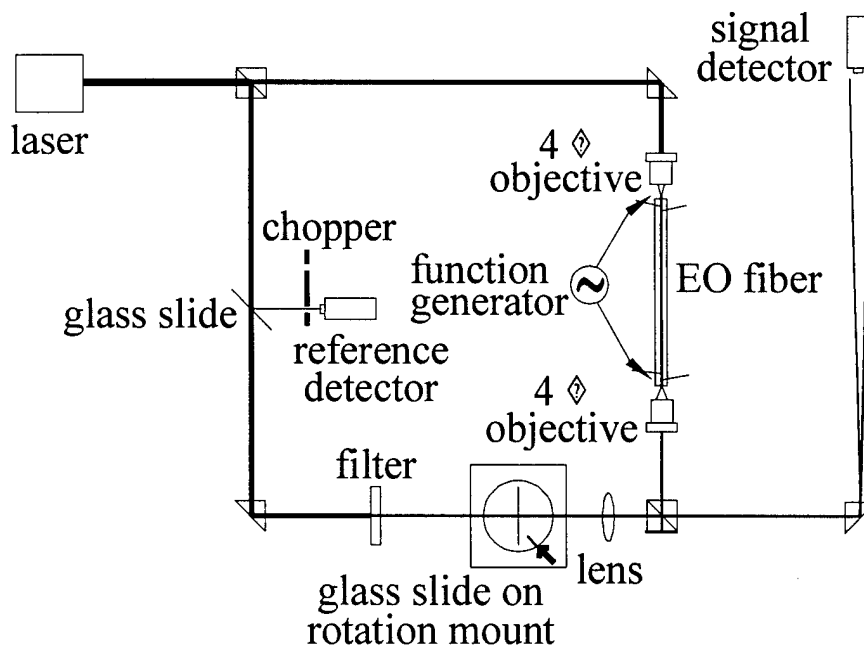

Figure 9. The electrooptic experiment.

The electrooptic effect is demonstrated in an electrooptic fiber by placing the fiber waveguide into one arm of an interferometer (see Figure 9). A glass slide is used to deflect part of the beam to a reference detector so that the intensity of the beam in the interferometer can be monitored. A glass slide on a rotation mount is used to adjust the optical path difference between the two arms of the interferometer. Light intensity is lost in the fiber arm due to coupling and propagation losses. An optical filter is placed in the reference arm to balance the intensities in both arms. The lens on the reference arm is used to adjust the divergence of the beam to match the divergence of the light leaving the microscope objective at the EO fiber. The result is a high contrast set of fringes at the detector. A sinusoidal voltage is applied to the fiber and the resultant modulation amplitude is measured with a photodiode detector. A lockin amplifier measures the modulation amplitude. The path differences between the two arms are adjusted to maximize the electrooptic signal. Figure 10 shows the modulation amplitude as a function of applied voltage. The linear behavior demonstrates that the linear electrooptic effect is the source of signal in the fiber. We have thus demonstrated electrooptic phase modulation in a polymer optical fiber.

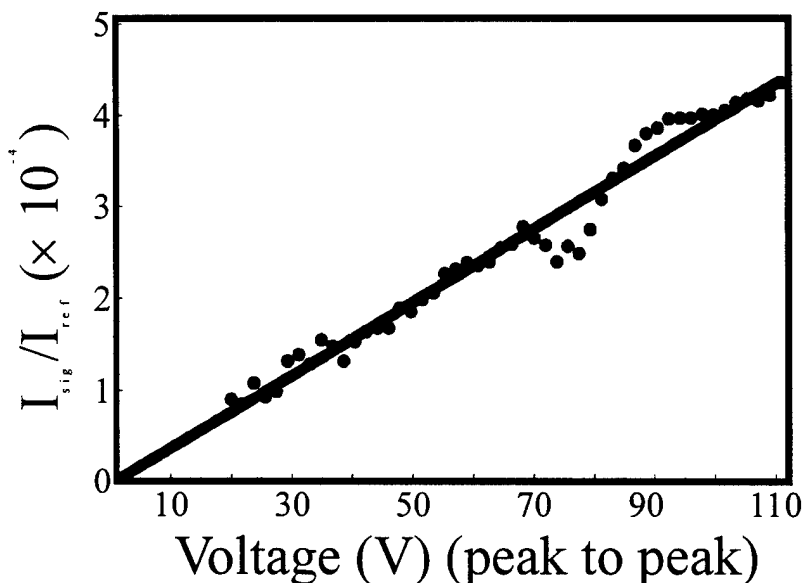

Figure 10. Electrooptic signal as a function of temperature.

In conclusion, we have demonstrated that an electrooptic fiber can be fabricated, poled, and that the dipoles are aligned in the poling as measured with thermally stimulated discharge. Furthermore, the fiber is demonstrated to be a linear phase modulator. We currently can routinely achieve modulation between 5-25% for different EO fibers. And have had one that gave us modulation of 80%. We are continuing our research efforts on a smaller scale and are seeking further funding for this project through both commercial and government routes. We have secured a small research grant of \$30,000 from the Washington Technology Council to develop better core materials. We are in the process of negotiating a contract with Allied Signal to incorporate their proprietary polymers to make polymer fiber and devices. The proposed contract is at a funding level of about \$150,000. In addition, Allied signal plans to dedicate a Chemist to the project who will come to Sentel every four to six weeks to work with Sentel to develop a process for making fibers with new materials.

Fabrication and Characterization of Single-mode Electrooptic Polymer Optical Fiber

David J. Welker and Jeff Tostenrude

Sentel Technologies L.L.C., Box 41-1, 1415 Eastgate Blvd, Pullman, WA 99163

Dennis W. Garvey, Brian K. Canfield, and Mark G. Kuzyk*

Department of Physics (*and Materials Science Program), Washington State University
Pullman, WA 99164-2814

Abstract: We report on what we believe is the first demonstration of single mode polymer optical fiber with embedded electrodes. We show that the electrodes can be used to pole the dye-doped core and to electro-optically phase modulate the light in the waveguide.

The fabrication process for making a polymer optical fiber with a dye-doped core is well enough defined to make a step index single-mode waveguide.[1][2] Graded index fibers have also been demonstrated.[3] Because the core diameter can be made small and dye doping renders the material highly optically nonlinear, such waveguides are well suited for making devices based on the intensity dependent refractive index.[4] In this paper, we report on the successful incorporation of indium electrodes that can be used to apply an electric field to the fiber core while the fiber is being drawn, and, that these same electrodes can be used to electro-optically modulate light. This makes possible a whole new class of polymer optical fiber devices based on second-order nonlinearity.

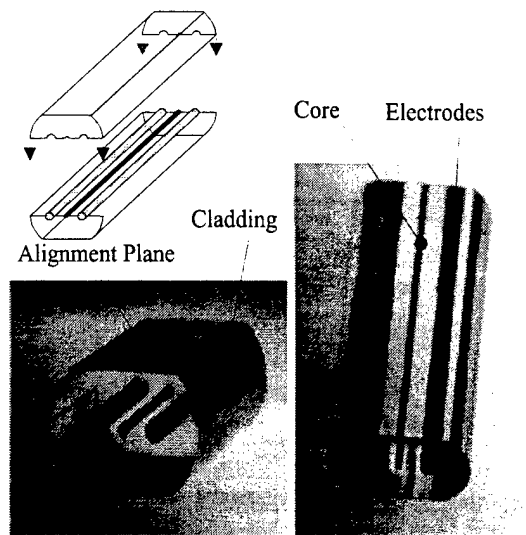

Figure 1. Process for making a preform and two views of a preform with a DR1/PMMA core and indium electrodes.

The first step is making the fiber preform from which the fiber is drawn. The process we use is similar to the one for making single mode fiber.[2] Two semicylinders with three grooves - one for the core and two for the electrodes - are pressed together at elevated temperature as shown in the top portion of

Figure 1. The bottom part of Figure 1 shows two views of a preform with a DR1(disperse red #1 azo dye)/PMMA(poly (methyl methacrylate)) core of 800 μm diameter, indium electrodes each of 2mm diameter, and an outer preform diameter of 12.7 mm. Two alignment planes are machined on the top and bottom of the preform in the PMMA cladding - parallel to the plane containing the electrodes and core.

The preform is pulled into a fiber in a drawing tower at about 230°C, which is above the glass transition temperature of the polymer and above the melting temperature of the indium. A high voltage power supply is attached to the electrode so that the dye-doped core can be poled [5] during the drawing process. As the fiber leaves the drawing oven, it cools and the alignment of the chromophores is frozen in place. Figure 2 shows a schematic of the drawing tower. The preform is about 10cm in length and, for a fiber diameter of 125 μm , draws into about 1km of fiber.

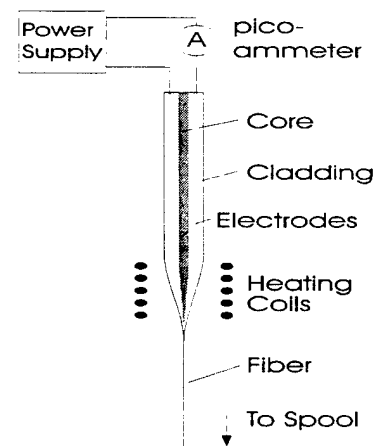

Figure 2. Drawing a fiber while poling with indium electrodes.

The current passing through the electrodes during poling is measured with an ammeter. A short during the poling process results in a spike in the current. Note that a large resistor(not shown), whose resistance is much lower than the resistance of the PMMA material that is being poled, is placed in

series with the ammeter to prevent damage to the poling electronics.

The hottest point in the fiber is found to be in the neck-down region.[2] Because ion mobility and free charge mobility increase when the polymer is heated, the measured current most likely passes between electrodes in the neck-down region. Similarly, the highest reorientational mobility of the dye chromophores is in the neck down region, so that it is also the region of highest degree of chromophore alignment. The neck-down region is thus the critical point in both fiber drawing and poling, and is the region monitored by the electronics.

Figure 3 shows a typical plot of the current as a function of time while an electrooptic fiber is drawn. This particular run illustrates the poling process. The total elapsed time corresponds to a fiber length of almost 1 km. When the fiber draw is started, a 1 kV voltage is applied across the electrodes. After about 100 s of drawing time, the voltage is increased to 2kV and the current approximately doubles. For 15 minutes, the current is approximately constant for a constant applied voltage, so the resistance in the neck-down region is approximately constant until 17 minutes into the draw. At that point, the current abruptly increases due to a short. Such a short can occur from an impurity in the neck-down region, dye aggregate, or imperfections in the preform. After the short is observed, the voltage is turned off and the fiber draw is allowed to continue for a few minutes before the voltage is turned on again. The measured current at 2kV is found to be about the same as it was just before the short. This is significant because it shows that a short along one part of a long fiber is not catastrophic to the remaining length of fiber. This observation can be understood as follows.

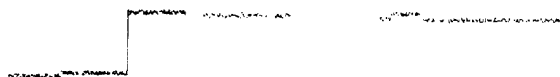

Figure 3. Current as a function of time.

The short most likely occurs at the neck-down region where the temperature is the highest. By turning off the poling field, the flow of the polymer at elevated temperature partially heals the short. When that region passes out of the heating zone, it cools, and the resistance increases. As the "shorted region" moves further away from the neck-down region, its effect on the total resistance also continues to go down. As a result, when the poling voltage is turned on, the material in the neck-down region is once again of high resistance, and the poling process continues similar to the pre-short conditions.

The 1km spool of fiber is then cut into small pieces for testing. 10cm to 20cm lengths of fiber are attached with epoxy to a plastic planar substrate. The plane containing the electrodes is guaranteed to be parallel to the substrate because of the alignment plane. The polymer fiber is micro-machined down to the electrodes so that leads can be attached. A lead is attached near each on of the electrodes with conducting epoxy so that a total of four leads is attached to a piece of fiber.[5] Details of lead attachment process will be described elsewhere.

The continuity of each electrode is measured using the pair of leads attached to either end of an electrode. For 40 μm diameter electrodes, the resistance is always found to be less than 0.1 ohm/cm. The resistance between electrodes during poling (above the glass transition temperature of the polymer) is about 300 M Ω while below the glass transition temperature after poling it is 50,000 M Ω . The degree of poling is measured using thermally stimulated discharge (TSD), where the fiber is placed on a hot plate, and the current is measured as a function of temperature. The main sources of current in a TSD measurement are trapped charges being freed by thermal activation, and, the reorientation of dipoles, which yield a displacement current. Figure 4 shows a TSD measurement of a poled fiber. The expected current for dipolar reorientation depends on the material number density, degree of poling, and electrode geometry. Based on our samples, we estimate that the current peak should be about 10 μA . This is consistent with the data, implying that fiber core is poled.

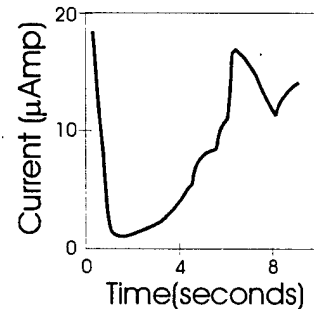

Figure 4. Current as a function of time after a hot plate turned on.

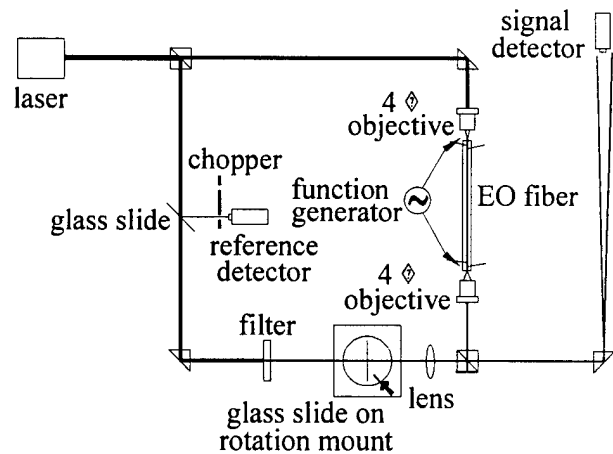

Figure 5. The electrooptic experiment.

The electrooptic effect is demonstrated in an electrooptic fiber by placing the fiber waveguide into one arm of an interferometer (see Figure 5). A glass slide is used to deflect part of the beam to a reference detector so that the intensity of the beam in the interferometer can be monitored. A glass slide on a rotation mount is used to adjust the optical path difference between the two arms of the interferometer. Light intensity is lost in the fiber arm due to coupling and propagation losses. An optical filter is placed in the reference arm to balance the intensities in both arms. The lens on the reference arm is used to adjust the divergence of the beam to match the divergence of the light leaving the microscope objective at the EO fiber. The result is a high contrast set of fringes at the detector. A sinusoidal voltage is applied to the fiber and the resultant modulation amplitude is measured with a photodiode detector. A lockin amplifier measures the modulation amplitude. The path differences between the two arms are adjusted to maximize the electrooptic signal. Figure 6 shows the modulation amplitude as a function of applied voltage. The linear behavior demonstrates that the linear electrooptic effect is the source of signal in the fiber. We have thus demonstrated electrooptic phase modulation in a polymer optical fiber.

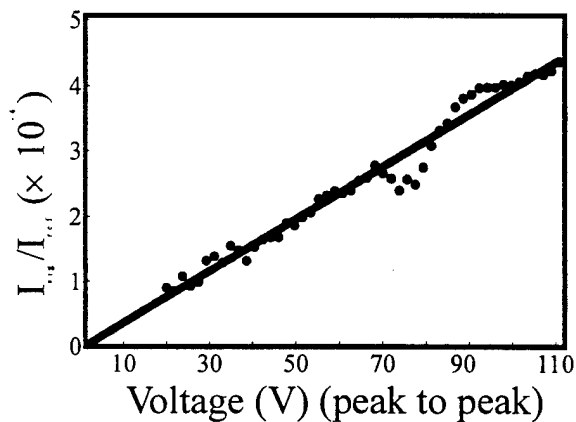

Figure 6. Electrooptic signal as a function of temperature.

In conclusion, we have demonstrated that an electrooptic fiber can be fabricated, poled, and that the dipoles are aligned in the poling as measured with thermally stimulated discharge. Furthermore, the fiber is demonstrated to be a linear phase modulator.

Acknowledgments: We thank the Air Force Office of Scientific Research for generously supporting this work.

References

1. M. G. Kuzyk, U. C. Paek, and C. W. Dirk, "Dye-Doped Polymer Fibers for Nonlinear Optics," *Appl. Phys. Lett.* **59**, 902 (1991).
2. D. W. Garvey, K. Zimmerman, P. Young, J. Tostenrude, J. S. Townsend, M. Lobel, M. Dayton, R. Wittorf, M. G. Kuzyk, J. Sunick, and C. W. Dirk, "Single-mode Nonlinear-Optical Polymer Fibers," *J. Opt. Soc. Am. B* **13**, 2017 (1996).
3. Y. Koike, N. Tanio, and Y. Ohtsuka, *Macromol.* **22**, 1367 (1989).

4. D. W. Garvey, Q. Li, M. G. Kuzyk, and C. W. Dirk, "Sagnac Interferometric Intensity Dependent Refractive Index Measurements of Polymer Optical Fiber," *Optics Letters* **21**, 104 (1996).

5. K. D. Singer, M. G. Kuzyk, and J. E. Sohn, "Second Harmonic Generation of Orientationally Ordered Materials," *J. Opt. Soc. Am. B* **4**, 78 (1987).

Single-mode Electrooptic Polymer Optical Fiber

David J. Welker and Jeff Tostenrude

Sentel Technologies L.L.C., Box 41-1, 1415 Eastgate Blvd, Pullman, WA 99163

Dennis W. Garvey, Brian K. Canfield, and Mark G. Kuzyk*

Department of Physics (*and Materials Science Program, email: mark_kuzyk@wsu.edu),
Washington State University
Pullman, WA 99164-2814

Abstract: We have made single mode polymer optical fiber with embedded electrodes. The electrodes can be used to pole the dye-doped core and electro-optic phase modulation of light in the waveguide has been demonstrated. The method of lead attachment to the electrodes is discussed and the optical/electrical properties of device structures characterized.

Keywords: Optical Fiber, polymer, electrodes, electrooptic, dyes

Polymer optical fiber with a dye-doped step index single-mode waveguide core has been made for several years with a well-defined and reliable process.[1][2] Koike and coworkers have demonstrated another process for making graded index fibers.[3] In step index fibers, the core diameter can be made arbitrarily small and dye doping is used to control the material's nonlinear refractive index and guiding properties. As such, these waveguides are well suited for making devices based on the intensity dependent refractive index.[4] Here, we report on the successful incorporation of indium electrodes that apply an electric field to the fiber core while the fiber is being pulled to render a second-order susceptibility. These same electrodes can be used to electro-optically modulate light in the fiber core. Our reported device structure therefore is the bases for any optical or electrical device that requires a second-order nonlinearity.

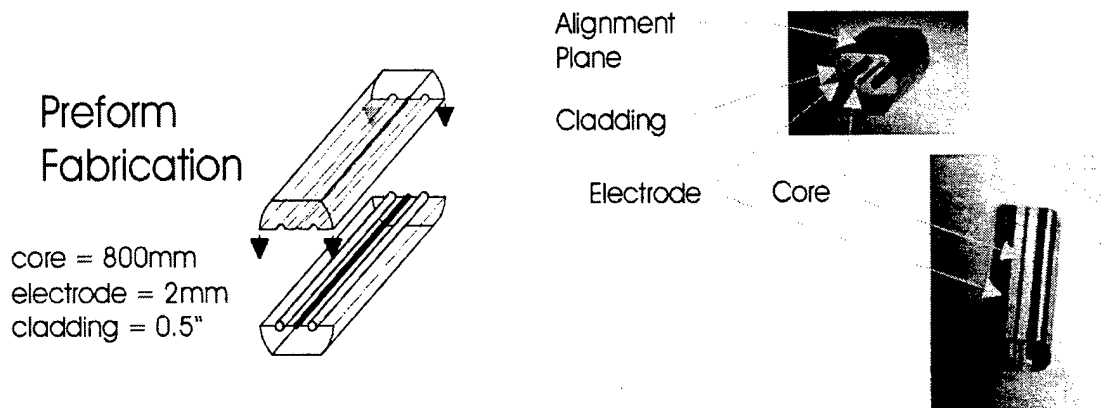

Figure 1. Process for making a preform and two views of a preform with a DR1/PMMA core and indium electrodes.

A fiber preform is fabricated and the fiber is drawn from this preform. The fabrication process is similar to the one for making single mode fiber.[2] Two semicylinders with three grooves - one for the core and two for the electrodes - are pressed together at elevated temperature as shown in the top portion of Figure 1. The bottom part of Figure 1 shows two views of a preform with a DR1(disperse red #1 azo dye)/PMMA(poly (methyl methacrylate)) core of 800 μm diameter, indium electrodes each of 2mm diameter, and an outer preform diameter of 12.7 mm. Two alignment planes are machined on the top and bottom of the preform in the PMMA cladding - parallel to the plane containing the electrodes and core.

The preform is pulled into a fiber in a drawing tower at about 230⁰C while the dye-doped core is poled[5]. When the fiber leaves the drawing oven, it cools to room temperature and the alignment of the chromophores locks in place. The current passing through the electrodes during poling is monitored with an ammeter and a large resistor in series to prevent damage to the poling electronics.

The peak temperature is in the neck-down region.[2] The increased ion mobility and free charge mobility during poling results in a current that probably passes between the electrodes in the neck-down region - where the dye chromophores also have the highest reorientational mobility. Thus, all the interesting physics occurs in the neck-down region.

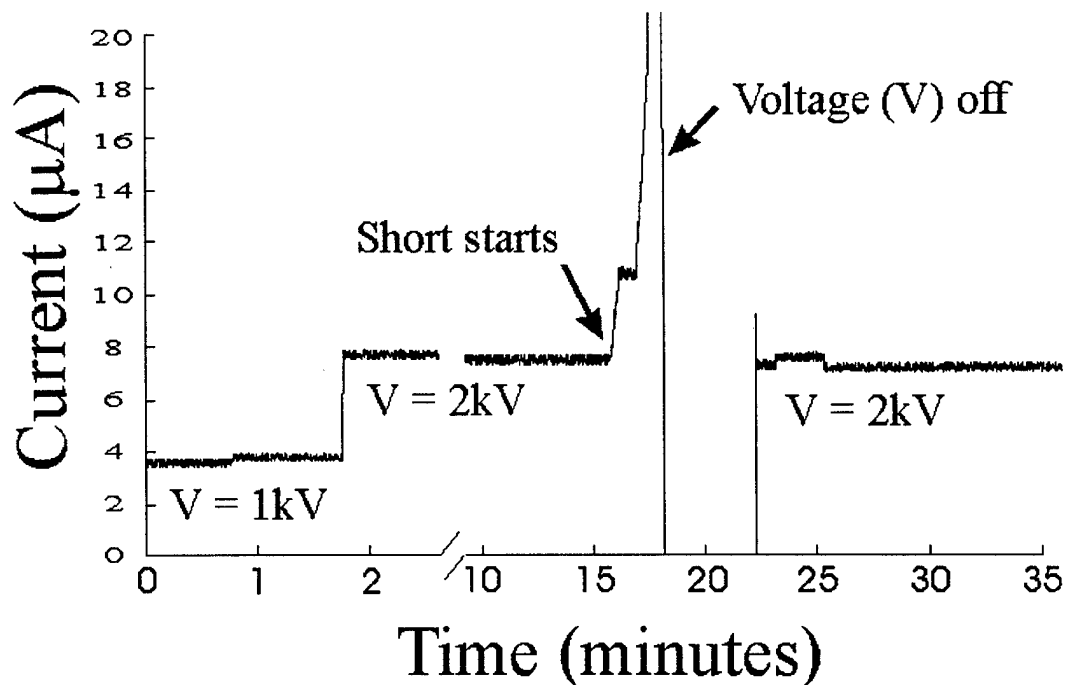

Figure 2. Current as a function of time.

Figure 2 shows the measured current as a function of time during a fiber draw. About 1 km of fiber is pulled over this run. A 1 kV voltage is applied across the electrodes followed by an applied step increase to 2kV after 100s of pulling. The current approximately doubles – as expected. The current is approximately constant for 15 minutes, so the resistance in the neck-down region is approximately constant for the first 17 minutes of the draw. The current abruptly increases due to a short, presumably from an impurity in the neck-down region, dye aggregate, or imperfections in the preform. Subsequently, the voltage is turned off and the fiber draws for a few minutes before the voltage is again turned on. The resistance is found to be the same as just prior to the short. This important results shows that a short along one part of a long fiber is not catastrophic to the remaining length of fiber, and can be understood as follows.

The short probably takes place in the neck-down region near the point of peak temperature. When the poling field is turned off, polymer flow at elevated temperature partially heals the short. When that region passes out of the heating zone, it cools, and the resistance increases. As the damaged region moves further away from the oven, its effect on the total resistance also continues to go down. Consequently, when the poling voltage is turned on, the material in the neck-down region is once again of high resistance, and the poling process continues similar to the pre-short conditions.

The 1km spool of fiber is cut into small pieces for testing. 10cm to 20cm lengths of fiber are attached with epoxy to a plastic planar substrate. The plane containing the electrodes is guaranteed to be parallel to the substrate because of the alignment plane. The polymer fiber is micro-machined down to the electrodes so that leads can be attached. A lead is attached near each end of the electrodes with conducting epoxy so that a total of four leads is attached to a piece of fiber.[6] Details of lead attachment process will be described elsewhere.

The continuity of each 40 μm diameter electrode is measured using one of the pairs of leads, and the resistance is always found to be less than 0.1 ohm/cm . The resistance between electrodes during poling (above the glass transition temperature of the polymer) is about 300 $\text{M}\Omega$ while below the glass transition temperature after poling it is 50,000 $\text{M}\Omega$.

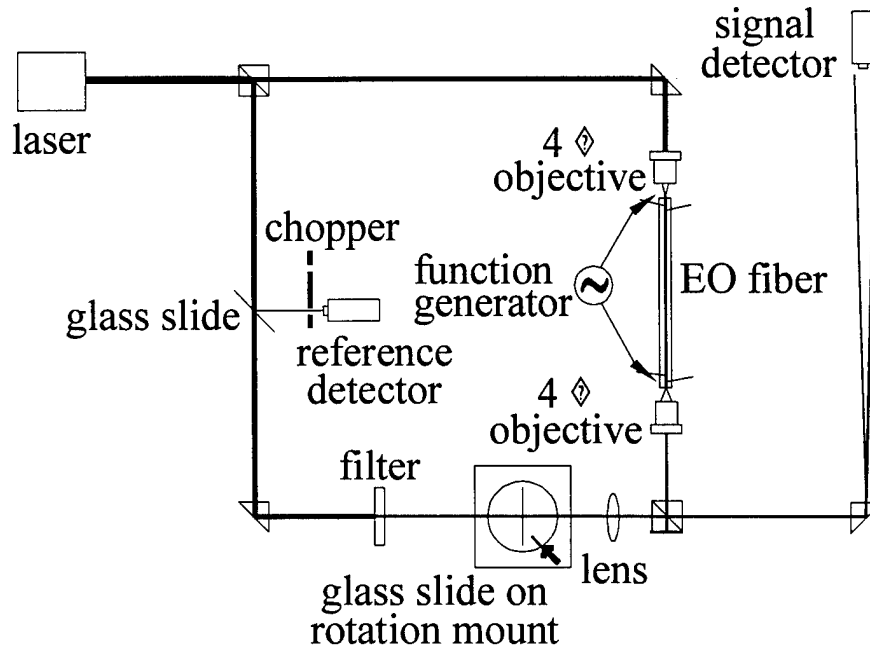
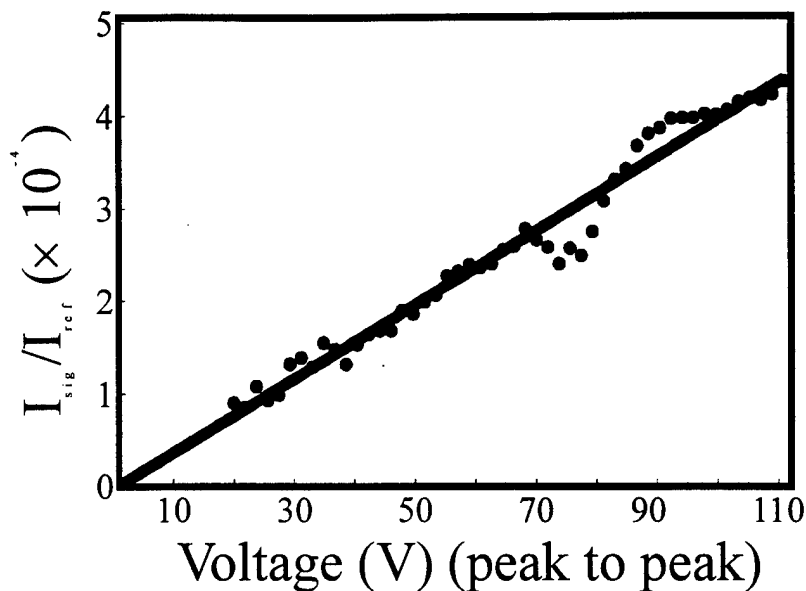

Figure 3. Electrooptic experiment.

The electrooptic effect is demonstrated in an electrooptic fiber by placing the fiber waveguide into one arm of an interferometer (see Figure 3). A glass slide is used to deflect part of the beam to a reference detector so that the intensity of the beam in the interferometer can be monitored. A glass slide on a rotation mount is used to adjust the optical path difference between the two arms of the interferometer. Light intensity is lost in the fiber arm due to coupling and propagation losses. An optical filter is placed in the reference arm to balance the intensities in both arms. The lens on the reference arm is used to adjust the divergence of the beam to match the divergence of the light leaving the microscope objective at the EO fiber. The result is a high contrast set of fringes at the detector. A sinusoidal voltage is applied to the fiber and the resultant modulation amplitude is measured with a photodiode detector. A lockin amplifier measures the modulation amplitude. The path differences between the two arms are adjusted to maximize the electrooptic signal. Figure 4 shows the modulation amplitude as a function of applied voltage. The linear behavior demonstrates that the linear electrooptic effect is the source of signal in the fiber. We have thus demonstrated electrooptic phase modulation in a polymer optical fiber.



In conclusion, we have demonstrated that an electrooptic fiber can be fabricated and poled. The resultant fiber is demonstrated to act as a phase modulator.

Acknowledgments: We thank the Air Force Office of Scientific Research for generously supporting this work.

References

1. M. G. Kuzyk, U. C. Paek, and C. W. Dirk, "Dye-Doped Polymer Fibers for Nonlinear Optics," *Appl. Phys. Lett.* **59**, 902 (1991).
2. D. W. Garvey, K. Zimmerman, P. Young, J. Tostenrude, J. S. Townsend, M. Lobel, M. Dayton, R. Wittorf, M. G. Kuzyk, J. Sunick, and C. W. Dirk, "A Single-mode Nonlinear-Optical Polymer Fiber," *J. Opt. Soc. Am. B* **13**, 2017 (1996).
3. Y. Koike, N. Tanio, and Y. Ohtsuka, *Macromol.* **22**, 1367 (1989).
4. D. W. Garvey, Q. Li, M. G. Kuzyk, and C. W. Dirk, "A Sagnac Interferometric Intensity Dependent Refractive Index Measurements of Polymer Optical Fiber," *Optics Letters* **21**, 104 (1996).
5. K. D. Singer, M. G. Kuzyk, and J. E. Sohn, "A Second Harmonic Generation of Orientationally Ordered Materials," *J. Opt. Soc. Am. B* **4**, 78 (1987).
6. <http://www.senteltech.com/>