

NAVAL POSTGRADUATE SCHOOL
Monterey, California



THESIS

**INVESTIGATION OF PRESSURE AND TEMPERATURE
SENSITIVITIES OF A PRESSURE SENSITIVE PAINT**

by

Peter D. Baumann

September 1998

Thesis Advisor:

Raymond P. Shreeve

Approved for public release; distribution is unlimited.

DTIC QUALITY INSPECTED 6

19981201 121

REPORT DOCUMENTATION PAGE

Form Approved
OMB No. 0704-0188

Public reporting burden for this collection of information is estimated to average 1 hour per response, including the time for reviewing instruction, searching existing data sources, gathering and maintaining the data needed, and completing and reviewing the collection of information. Send comments regarding this burden estimate or any other aspect of this collection of information, including suggestions for reducing this burden, to Washington headquarters Services, Directorate for Information Operations and Reports, 1215 Jefferson Davis Highway, Suite 1204, Arlington, VA 22202-4302, and to the Office of Management and Budget, Paperwork Reduction Project (0704-0188) Washington DC 20503.

1. AGENCY USE ONLY (Leave blank)		2. REPORT DATE September 1998	3. REPORT TYPE AND DATES COVERED Master's Thesis	
4. TITLE AND SUBTITLE: INVESTIGATION OF PRESSURE AND TEMPERATURE SENSITIVITIES OF A PRESSURE SENSITIVE PAINT			5. FUNDING NUMBERS	
6. AUTHOR(S) CDR Peter D. Baumann, USN			8. PERFORMING ORGANIZATION REPORT NUMBER	
7. PERFORMING ORGANIZATION NAME(S) AND ADDRESS(ES) Naval Postgraduate School Monterey, CA 93943-5000			10. SPONSORING / MONITORING AGENCY REPORT NUMBER	
9. SPONSORING / MONITORING AGENCY NAME(S) AND ADDRESS(ES)			10. SPONSORING / MONITORING AGENCY REPORT NUMBER	
11. SUPPLEMENTARY NOTES The views expressed in this thesis are those of the author and do not reflect the official policy or position of the Department of Defense or the U.S. Government.				
12a. DISTRIBUTION / AVAILABILITY STATEMENT Approved for public release; distribution is unlimited.			12b. DISTRIBUTION CODE	
13. ABSTRACT (maximum 200 words) In the development of a surface pressure measurement system for transonic compressor rotors, it has been shown that Pressure Sensitive Paint (PSP) is also temperature dependent. In the present study, the sensitivities to pressure and temperature were examined experimentally using an electronically-gated, intensified Charged-Coupled-Device (CCD) video camera, frame-grabber software and an eight-inch diameter calibration chamber. Using a signal generator, in a procedure that matched the requirements of the rotor application, multiple low-intensity-level camera exposures were integrated and captured to produce a single usable image. Ten captured images were averaged to increase the image's signal-to-noise ratio and the result was used to produce an image ratio with respect to a static (ambient pressure/temperature) reference condition. Calibration tests of constant temperature/variable pressure and constant pressure/variable temperature were completed. The results were then compared with data obtained using the same paint and an automated, single-exposure calibration procedure at NASA Ames Research Center. It was shown that the calibration data could be used to derive the static pressure field produced over a high-speed test rotor using PSP and the same image-capture system used in the calibration. In preparation for a bench test of the procedure, a uniform-stress, high-speed test rotor disk, fitted with a shock generator was driven at speeds in excess of 30,000 RPM. Recommendations are made toward the goal of obtaining quantitative pressure measurements on transonic compressor rotors.				
14. SUBJECT TERMS Pressure Sensitive Paint, PSP, Charged Couple Device Camera, CCD, Photoluminescence, Imaging, Luminescence, PtOEP, UV illumination, Detection, Emission, Aerodynamics, Measurements, Temperature and Pressure Calibration.			15. NUMBER OF PAGES 105	
17. SECURITY CLASSIFICATION OF REPORT Unclassified			16. PRICE CODE	
18. SECURITY CLASSIFICATION OF THIS PAGE Unclassified		19. SECURITY CLASSIFICATION OF ABSTRACT Unclassified		20. LIMITATION OF ABSTRACT UL

NSN7540-01-280-5500

Standard Form 298 (Rev. 2-89)
Prescribed by ANSI Std. Z39-18
298-102

Approved for public release; distribution is unlimited

**INVESTIGATION OF PRESSURE AND TEMPERATURE SENSITIVITIES OF
A PRESSURE SENSITIVE PAINT**

Peter D. Baumann
Commander, United States Navy
B.A., University of California at Santa Cruz, 1979

Submitted in partial fulfillment of the
requirements for the degree of

MASTER OF SCIENCE IN AERONAUTICAL ENGINEERING

from the

**NAVAL POSTGRADUATE SCHOOL
September 1998**

Author:

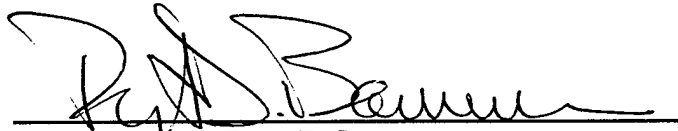
Peter D. Baumann

Approved by:

Raymond P. Shreeve, Thesis Advisor

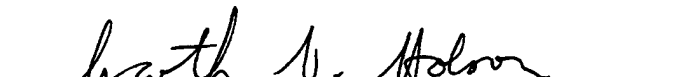
Garth V. Hobson, Second Reader

Gerald H. Lindsey, Chairman
Department of Aeronautics and Astronautics

ABSTRACT

In the development of a surface pressure measurement system for transonic compressor rotors, it has been shown that Pressure Sensitive Paint (PSP) is also temperature dependent. In the present study, the sensitivities to pressure and temperature were examined experimentally using an electronically-gated, intensified Charged-Coupled-Device (CCD) video camera, frame-grabber software and an eight-inch diameter calibration chamber. Using a signal generator, in a procedure that matched the requirements of the rotor application, multiple low-intensity-level camera exposures were integrated and captured to produce a single usable image. Ten captured images were averaged to increase the image's signal-to-noise ratio and the result was used to produce an image ratio with respect to a static (ambient pressure/temperature) reference condition. Calibration tests of constant temperature/variable pressure and constant pressure/variable temperature were completed. The results were then compared with data obtained using the same paint and an automated, single-exposure calibration procedure at NASA Ames Research Center. It was shown that the calibration data could be used to derive the static pressure field produced over a high-speed test rotor using PSP and the same image-capture system used in the calibration. In preparation for a bench test of the procedure, a uniform-stress, high-speed test rotor disk, fitted with a shock generator was driven at speeds in excess of 30,000 RPM. Recommendations are made toward the goal of obtaining quantitative pressure measurements on transonic compressor rotors.

TABLE OF CONTENTS

I. INTRODUCTION.....	1
A. PURPOSE.....	1
B. OVERVIEW	1
1. Early Turbomachinery Applications.....	2
2. PSP Calibration and Application.....	2
3. Suitability of PSP for Transonic Rotor CFD Design Validation.....	3
II. ANALYSIS.....	5
A. THEORETICAL BACKGROUND.....	5
B. TEMPERATURE DEPENDENCE	5
C. METHODS TO ACCOUNT FOR TEMPERATURE DEPENDENCE	7
D. INDEPENDENCE OF CALIBRATION TECHNIQUE.....	9
III. TEST EQUIPMENT AND PROCEDURES	11
A. NPS CALIBRATION SETUP.....	11
1. NPS Calibration Setup.....	11
2. Test Conditions and Procedures	16
3. Data Acquisition and Reduction.....	17
a. Data Acquisition.....	17
b. Data Reduction	18
B. NASA-AMES RESEARCH CENTER CALIBRATION.....	20
1. NASA Calibration Setup	20
2. Tests and Test Conditions.....	22
3. Data Acquisition and Reduction.....	23
IV. RESULTS AND DISCUSSION	25
A. CONSTANT-TEMPERATURE, VARIABLE-PRESSURE RESULTS	25

B. EFFECTS OF SHELLAC COATING ON PSP RESPONSE	26
C. CONSTANT PRESSURE, VARIABLE TEMPERATURE RESULTS	28
D. TIME DETERIORATION TEST RESULTS.....	30
E. REPEATABILITY	31
V. CONCLUSIONS AND RECOMMENDATIONS	35
A. CONCLUSIONS.....	35
B. RECOMMENDATIONS.....	36
APPENDIX A. ANALYTICAL FRAMEWORK FOR THE CALIBRATION AND APPLICATION OF PSP	39
APPENDIX B. CAPTURED IMAGE DATA (RAW IMAGE DATA).....	45
B.1 CONSTANT-TEMPERATURE, VARIABLE-PRESSURE IMAGE DATA.....	45
B.2 CONSTANT-PRESSURE, VARIABLE-TEMPERATURE RAW IMAGE DATA.....	49
B.3 TIME DETERIORATION RAW IMAGE DATA.....	50
APPENDIX C. CORRECTED CONSTANT-TEMPERATURE, VARIABLE- PRESSURE DATA CALCULATIONS	51
C.1 CORRECTED CONSTANT-TEMPERATURE, VARIABLE- PRESSURE DATA.....	51
C.2 CORRECTED HIGH ERROR POINT REJECTION DATA SHEETS	53
C.3 CORRECTED HIGH ERROR POINT REJECTION FIGURES	55
APPENDIX D. NASA-AMES CALIBRATION DATA	59

APPENDIX E. WOODMANSEE DATA.....	71
APPENDIX F. INDIVIDUAL LINEAR AND QUADRATIC CURVE FIT FIGURES.....	73
APPENDIX G. TEST ROTOR MODIFICATIONS.....	77
LIST OF REFERENCES.....	79
INITIAL DISTRIBUTION LIST.....	83

LIST OF FIGURES

Figure 1. Effect of Temperature on PSP Response From Kanvandi [Ref. 11]	6
Figure 2. Effect of Temperature on Coating Calibration Curves From Kavandi [Ref. 11] (a) I_o for Curve Measured at 23.7° C. (b) I_o for curve taken at its Respective Temperature	7
Figure 3. NPS PSP Calibration Experimental Setup.....	12
Figure 4. Image Acquisition System From Quinn [Ref. 3].....	13
Figure 5. Calibration Pressure Chamber with Vacuum and Pressure Line	14
Figure 6. Image Capture Timing Sequence From Quinn [Ref. 3].....	15
Figure 7. NASA-Ames PSP Calibration Apparatus.....	21
Figure 8. Mensor CPS 4000 Pressure Calibration System.....	22
Figure 9. NPS and NASA Calibration Data with Linear Curves Fitted.....	27
Figure 10. NPS and NASA Calibration Data with Quadractic Curves Fitted.....	27
Figure 11. Constant-Pressure, Varing-Temperature Results (I_o at 14.8 psi and 71.9° F)	29
Figure 12. Comparison of Woodmansee Data with NPS Data	30
Figure 13. Time Deterioration Calibration Test Results	31
Figure 14. NPS Constant-Temperature, Variable-Pressure Repeatability (72°- 73° F)	32

Figure 15. NPS Constant-Temperature, Variable-Pressure Repeatability (100°–125° F)	33
Figure C1. AC-5 Corrected Intensity Ratio.....	55
Figure C2. AC-6 Corrected Intensity Ratio.....	56
Figure C3. AC-8 Corrected Intensity Ratio.....	56
Figure C4. AC-8 Corrected Intensity Ratio.....	57
Figure C5. AC-8 Corrected Intensity Ratio.....	57
Figure D1. NASA-Ames PSP Calibration at 38° F.....	68
Figure D2. NASA-Ames PSP Calibration at 53° F.....	68
Figure D3. NASA-Ames PSP Calibration at 68° F.....	69
Figure E1. Original Woodmansee Data From [Ref. 8]	72
Figure F1. AC-5 Constant-Temperature, Variable-Pressure (72 ⁰ F)	73
Figure F2. AC-6 Constant-Temperature, Variable-Pressure (73 ⁰ F)	74
Figure F3. AC-8 Constant-Temperature, Variable-Pressure (125 ⁰ F)	74
Figure F4. AC-9 Constant-Temperature, Variable-Pressure (100 ⁰ F)	75
Figure F5. AC-10 Constant-Temperature, Variable-Pressure (85 ⁰ F)	75

Figure G1. Test Rotor with Laser Modification.....77

LIST OF TABLES

Table 1. Constant-Temperature, Variable-Pressure Test Conditions.....	17
Table 2. Constant-Pressure, Variable-Temperature Test Conditions.....	17
Table 3. Time Deterioration Test Conditions.....	17
Table 4. Pixel Noise Rejection Criteria.....	19
Table 5. NASA-Ames Calibration Test Conditions.....	23
Table B1. AC-0 Raw Image Data (73 ^o F).....	45
Table B2. AC-1 Raw Image Data (100 ^o F).....	45
Table B3. AC-3 Raw Image Data (120 ^o F).....	46
Table B4. AC-4 Raw Image Data (100 ^o F).....	46
Table B5. AC-5 Raw Image Data (72 ^o F).....	46
Table B6. AC-6 Raw Image Data (73 ^o F).....	47
Table B7. AC-7 Raw Image Data (125 ^o F).....	47
Table B8. AC-8 Raw Image Data (125 ^o F).....	48
Table B9. Raw Image Data (100 ^o F).....	48
Table B10. Raw Image Data (85 ^o F).....	48
Table B11. BC-2 Raw Image Data (0.5 psi).....	49

Table B12. BC-1 Raw Image Data (14.8 psi)	49
Table B13. BC-4 Raw Image Data (25.0 psi)	50
Table B14. BC-3 Time Deterioration (80° F).....	50
Table C1. AC-5 72° F Constant-Temperature, Variable-Pressure	51
Table C2. AC-6 73° F Constant-Temperature, Variable-Pressure	51
Table C3. AC-8 125° F Constant-Temperature, Variable-Pressure	52
Table C4. AC-9 100° F Constant-Temperature, Variable-Pressure	52
Table C5. AC-10 85° F Constant-Temperature, Variable-Pressure	53
Table C6. AC-5 72° F Constant-Temperature, Variable-Pressure	53
Table C7. AC-6 73° F Constant-Temperature, Variable-Pressure	54
Table C8. AC-8 125° F Constant-Temperature, Variable-Pressure	54
Table C9. AC-9 100° F Constant-Temperature, Variable-Pressure	54
Table C10. AC-10 85° F Constant-Temperature, Variable-Pressure	55
Table D1. PSP Constant-Temperature, Variable-Pressure (68° F)	59
Table D2. PSP Constant-Temperature, Variable-Pressure (68° F) Repeated	60
Table D3. PSP-Shellac Constant-Temperature, Variable-Pressure (38° F)	61

Table D4. PSP-Shellac Constant-Temperature, Variable-Pressure (68° F)	62
Table D5. PSP-Shellac Constant-Temperature, Variable-Pressure (53° F)	63
Table D6. PSP Constant-Temperature, Variable-Pressure (38° F) Repeated	64
Table D7. PSP Constant-Temperature, Variable-Pressure (53° F)	65
Table D8. PSP Constant-Temperature, Variable-Pressure (68° F) Repeated	66
Table D9. PSP Constant-Temperature, Variable-Pressure (68° F) Repeated	67
Table E1. Woodmansee Data [Ref. 8] Conversion (^o C to ^o F).....	71
Table E2. Extrapolation and I _{Ref} change to 70° F of Woodmansee Data [Ref. 8].....	71
Table G1. Test Rotor Test Conditions	78

ACKNOWLEDGEMENTS

I extend my appreciation to several people whose efforts greatly contributed towards the development of this thesis.

I would like to thank the Pressure Sensitive Paint researchers at NASA-Ames Research Center, particularly Dr. James Bell, and Mr. Ed Schairer for their advice and technical support. In addition, the assistance provided by Mr. Lance Foster, a undergraduate student at University of Florida, A & M on summer internship at NASA-Ames, and Dr. Robi Mehta in the collection of pressure sensitive paint calibration data on the NASA-Ames calibration bench.

I would also like to thank Mr. Rick Still of the Department of Aeronautics and Astronautics for his technical support in the logistics, planning, and on-sight trouble shooting and good humor throughout this project.

I greatly appreciate the efforts of Dr. Raymond Shreeve in providing the opportunity to pursue this thesis. Without his incredible patience, sage guidance, and dedicated support, this research would never have been completed.

I would also like to thank my wife, Ms. Laura Baumann, for the continuous love and support she has given me.

I. INTRODUCTION

A. PURPOSE

The purpose of this investigation was to examine the pressure and temperature sensitivities of pressure sensitive paint (PSP), and to develop a procedure to derive the pressure from PSP measurements made on a rotor. One PSP was investigated, Platinum Octethyl Prophyrin (PtEOP). The longer-term goal is to use PSP to validate the design and flowfield analysis of advanced transonic rotors performed using 3D viscous computational fluid dynamics (CFD) codes. A code-validation transonic compressor stage is currently under test at the TurboPropulsion Laboratory at the Naval Postgraduate School.

B. OVERVIEW

Pressure sensitive paints are gaining wide acceptance as a method of measuring pressure distributions on aerodynamic surfaces in wind tunnels. Potentially, there is an enormous advantage to be gained by replacing the conventional discrete point pressure taps/pressure transducers with a surface layer of PSP. It could enable a continuous and detailed surface pressure mapping. To date, PSP has been used to obtain qualitative and, only to a limited degree, quantitative pressure distributions in wind tunnel and flight applications. The goal of obtaining accurate quantitative pressure measurement through use of PSP has been recognized and pursued more recently by the turbomachinery community, since it is always very difficult to instrument rotating parts. Advances in PSP and binder systems are continuously being made, and paints are currently available that are sensitive to pressures from about 1/100 of an atmosphere to 2 atmospheres (0.2 to 29.4 psi).

1. Early Turbomachinery Applications

Several recent investigators have obtained promising results from attempts at surface pressure mapping of turbomachinery, while identifying some remaining challenges [Ref. 1]. Common problems associated with turbomachinery applications were identified by Bencic [Ref. 2]:

1. Obtaining optical access to the entire surface
2. Producing enough short duration pulsed light for excitation (This does not apply in the technique reported here)
3. Detection of luminescent paint on high-speed surfaces and at low light levels of emitted signal (high pressure and/or high temperature).
4. Determining an accurate calibration to apply without resorting to 'in-situ' instrumentation.

Other issues that make quantitative pressure measurements difficult using PSP is the inherent temperature dependence [Ref. 3] and the separation of explicit temperature compensation from photodegradation and shelf life degradation reported by McLachlan [Ref. 4].

2. PSP Calibration and Application

The focus of the present investigation was on the fourth problem area; that is, determining an accurate calibration to apply without the need for the additional instrumentation that is required to apply 'in-situ' calibration. A complete calibration and application method involves the following steps: (1) Full characterization of the paint behavior over the pressure and temperature range of interest; (2) Analytical representation (approximation) of the measured behavior; (3) Derivation of a procedure and solution algorithm to derive pressure (and temperature) from intensity (and possibly other) measurements, in the application. Note that the procedure and solution algorithm used in wind tunnel experiments might be quite different from those derived for turbomachinery applications.

3. Suitability of PSP for Transonic Rotor CFD Design Validation

Surface pressure data obtained with PSP are to be used to validate the design (and off-design behavior) of the "Sanger" transonic rotor [Ref. 5]. The proposed application, and the method of approach adopted, offer several useful features [Ref. 3 and Ref.6]: (1) The entire front surface of the transonic rotor is optically accessible; (2) Continuous UV illumination, steady rotor flow conditions, and use of a gated CCD camera, can provide adequate excitation and controllable levels of image intensity; (3) Images can be acquired from more than one rotor blade by controlling a delay in the trigger signal.

Following an examination of early calibration results, an analytical representation was suggested by Shreeve [Ref. 7], which accounts for pressure and temperature dependence. [See Appendix A]. If the representation given in Appendix A, is used, then "wind-on" and "wind-off" images are required in the application from two rotor blades painted with paints whose sensitivities are different. It is also necessary that the temperature be known for the "wind-off" condition. However, the analysis also raised three questions which are fundamental to the goal of obtaining code-validation data, namely:

- 1) Is the calibration process "situation dependent"?
- 2) Can you obtain pressure-independence (i.e. just temperature dependence) by sealing the PSP?
- 3) Is the pressure and temperature sensitivity of PtOEP suitable for the intended transonic compressor application?

The present study provided initial responses to all three questions. Calibrations of coupon samples of PSP were carried out at the Naval Postgraduate School (NPS) and at NASA-Ames Research Center using very different calibration chambers and intensity recording methods. In reporting this work, Chapter II provides some background on the theory of

pressure sensitive paints, primarily photoluminescent paints, discusses some of the problems involved in the calibration of PSP, and introduces a method of calculating the pressure and temperature coefficients. Chapter III describes the experimental setups and tests conducted at NPS, and at NASA-Ames Research Center. Chapter IV reports the calibration test data obtained at NPS, and at NASA-Ames, and compares the two sets of results. Chapter IV also discusses the repeatability of the NPS calibration. Chapter V contains the conclusions and recommendations.

The Appendices are divided into functional groups of test data and calculations. Appendix A contains an analytical framework for the calibration and application of PSP developed by Shreeve [Ref. 7]. Appendix B consists of the unprocessed captured image data referred to as the "Raw Image data," from the NPS calibration tests. These data tables give the image intensity for each test condition (point) calculated as the average of the (y-mean) pixels at a fixed position on each image. The data were recorded in a Microsoft ExcelTM spreadsheet. Appendix C consists of the same image data as in Appendix B, but corrected to eliminate noise, and only for tests which were conducted in a constant-temperature, variable-pressure mode. Appendix D contains the NASA-Ames calibration data. Appendix E contains data derived from Woodmansee [Ref. 8], converted from KPa/ $^{\circ}$ C to psi/ $^{\circ}$ F, extrapolated and then normalized to a reference temperature of 70 $^{\circ}$ F. Appendix F gives figures containing linear and quadratic curve fits to five corrected constant-temperature, variable-pressure calibration tests conducted at NPS. Appendix G reports modifications made to the test rotor, which enabled rotational speeds of 30,000 rpm to be achieved.

II. ANALYSIS

A. THEORETICAL BACKGROUND

The current PSP used in the present study was Platinum Octaethyl Prophyrin (PtEOP). The active molecule, PtEOP was dissolved in an oxygen-permeable binder (GP-197) [Ref. 6]. PtEOP is a photoluminescent molecule, which emits a photon when returning to the ground electronic state. In this process the molecule is excited by UV light at absorption peak of 380 nm and the emitted light is red-shifted to 650nm. The presence of oxygen molecules interferes with the photon emission process by absorbing the excess energy during collisional deactivation. This process is called dynamic quenching [Ref. 9]. The photoluminescence, oxygen quenching phenomenon is theoretically modeled by the Stern-Volmer relation:

$$I_0/I = A(T) + B(T)P/P_0 \quad (1)$$

where I_0 and P_0 are the reference ("wind-off") luminescent intensities and reference pressure, respectively, and I and P are the intensity and pressure measured ("wind-on") at the experimental condition. The coefficients A and B are derived from calibration data and generally are temperature dependent [Ref. 6]. The luminescence, which depends on the oxygen concentration, can be used to calculate the pressure because oxygen has a constant mole fraction of 0.21 in air. More detailed fundamental theory on the chemical processes involved in PSP can be found in Willard et al [Ref. 10], and McLachlan et al [Ref. 4].

B. TEMPERATURE DEPENDENCE

Pressure sensitive paints are temperature sensitive not only due to the dependence on temperature of the photoluminescence itself, but also to a

lesser degree, to the properties of various binders used with the PSP. In general, as shown in Figure 1, taken from Kavandi [Ref. 11], PSP emits at decreasing intensity with increasing temperature. Furthermore, as shown in Figures 2a, and 2b, taken from [Ref. 11], temperature dependence affects the calibration curves of intensity vs pressure. For experimental purposes, calibration and data reduction make use of the ratio I_0/I in the Stern-Volmer relation shown in equation (1). McLachlan [Ref. 4] noted that the ratio of I_0/I eliminates the effects of surface spatial non-uniformity in excitation light intensity, thickness of the paint coat, and concentration distributions of the molecules in the coat. To apply temperature corrections to pressures deduced from prior calibration, the temperatures need to be known at every pixel location [Ref. 8].

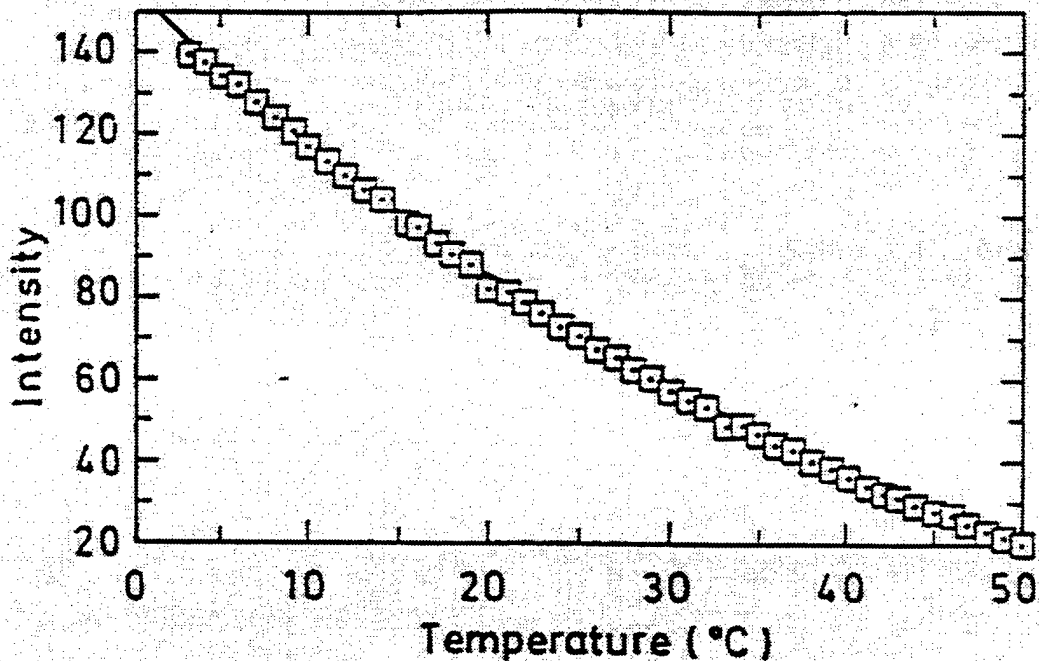

Figure 1. Effect of Temperature on PSP Response From Kavandi [Ref. 11]

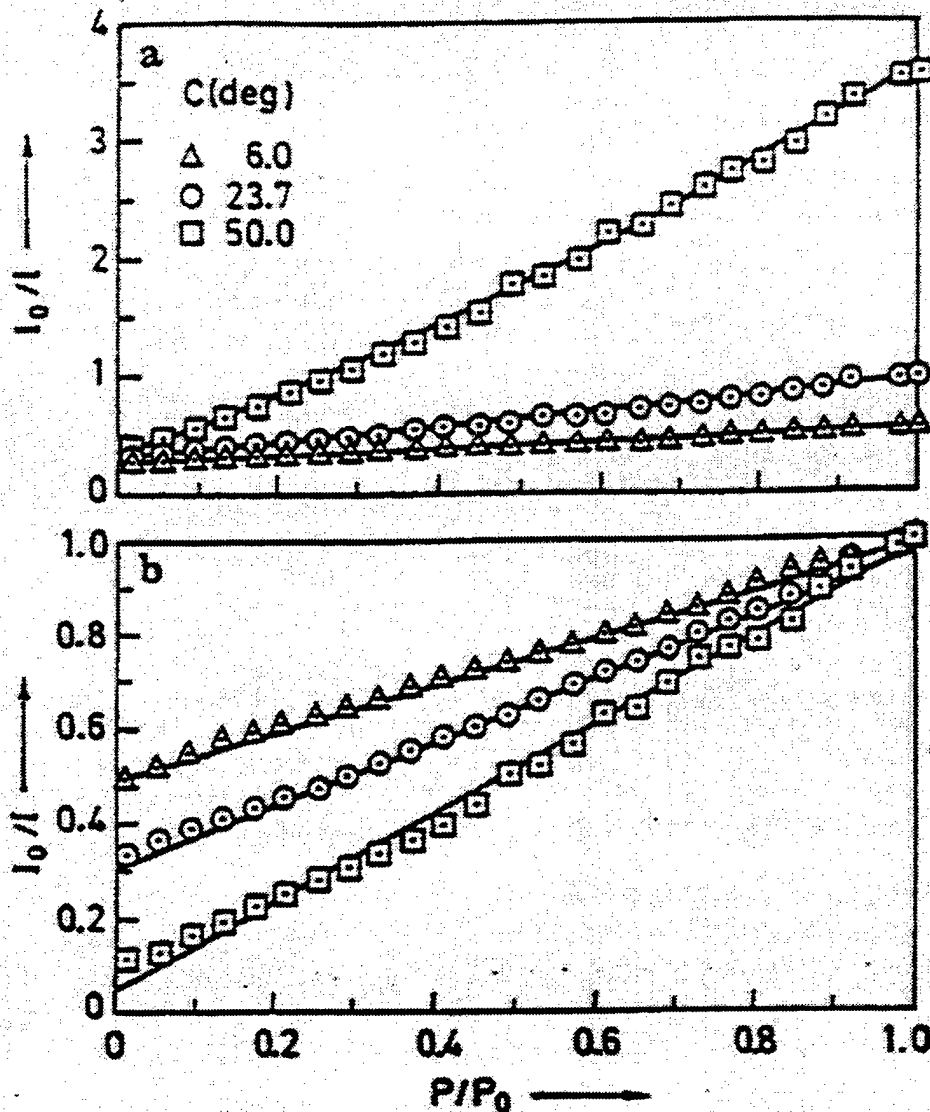

Figure 2. Effect of Temperature on Coating Calibration Curves From Kavandi [Ref. 11]
 (a) I_0 for Curve Measured at 23.7° C. (b) I_0 for curve taken at its
 Respective Temperature .

C. METHODS TO ACCOUNT FOR TEMPERATURE DEPENDENCE

Woodmansee [Ref. 8] recently suggested four methods for temperature correction in PSP measurements: (1) Isothermal; (2) In-situ; (3) K-Fit; and (4) Direct temperature correction. In considering these

methods for the NPS transonic compressor application, we find: (1) The Isothermal method is not valid, since the temperature will vary significantly over the compressor rotor; (2) The in-situ method is not possible, since the blades are too thin to install pressure taps/pressure transducers, and there is no provision for transmitting on-rotor measurements; (3) The K-Fit method assumes both negligible pressure gradients, and isothermal conditions, which are not the case on a transonic rotor; and (4) The direct temperature correction requires temperature correction on a pixel-to-pixel basis, and therefore a method of temperature mapping, concurrent with PSP mapping, would be required. Such an approach was reported recently by Navarra, et al [Ref. 12].

An alternative approach to "temperature correction" is to recognize that the paint is both pressure and temperature dependent, and to see what must be done to derive pressure and temperature from (in principle) two different measurements. The analytical framework for this approach is given in Appendix A. The analysis, which retains the Stern-Volmer equation but allows non-linearity, suggests two different paths to solve the problem. The first approach is to use a temperature-sensitive paint (TSP), along with the PSP, as reviewed in Navarra, et al [Ref. 12]. The second approach is to use two different PSPs, which have different response characteristics to temperature and pressure. Ideally, a clear coating to seal out the pressure effects from the PSP entirely could be used, or alternatively, a specially mixed binder that would change the characteristic response of the PSP to pressure and temperature could be used. The benefit of using the same active molecule is that only one image acquisition system need be used (with all of the required filters). Pressures and temperatures at each pixel can be calculated once the response of the chosen PSP/binder and/or TSP/binder systems are determined under calibrated pressure and temperature conditions. Note that the temperature also needs to be known at wind-off conditions. For

this (or any other current approach) to work, the three questions posed in the introduction must be answered. To begin, an accurate calibration, establishing the response of the paint, or paints, in use, must be known for all conditions of pressure and temperature within the ranges to be encountered in the application.

D. INDEPENDENCE OF CALIBRATION TECHNIQUE

The ideal situation would occur if a standardized set of calibration coefficients could be established for each PSP/binder. Standardized calibration coefficients would have to be independent of the particular calibration technique utilized. Indeed, if this is not the case, the coefficients established in a laboratory calibration experiment could not be used to reduce PSP data obtained with an entirely different setup on a test rig. Different calibration techniques can be used to examine this fundamental question. The intensity ratio (I_0/I) is the essential parameter used in establishing the calibration and reporting such data in the literature, since it is assumed to be independent of set-up. If the intensity ratio (I_0/I) of a given PSP/binder system shows the same response under similar pressure and temperature test conditions, but using different light sources, windows and detection techniques, standardized calibration coefficients, which are then independent of the calibration technique, can be derived. To this end, the present investigation compared results of three different experiments involving PtOEP as the active PSP molecule, two conducted in laboratories at NPS and NASA-Ames Research Center, and one reported by Woodmansee [Ref. 8]. Also, the attempt was made to use alcohol-based shellac to seal the PSP and make it insensitive to pressure.

III. TEST EQUIPMENT AND PROCEDURES

The calibration experiments conducted at NPS and NASA-Ames Research Center were quite different. At NASA, an automated process was used that incorporated a photo-diode to measure the integrated light intensity from a sample coupon. At NPS, a manual process was used that involved using the same gated intensified charge-coupled device (CCD) camera and acquisition procedures that were used to acquire data from PSP on a test rotor.

The gated CCD camera offered advantages for turbomachinery applications of PSP, some of which are also of benefit in the calibration process: (1) High spatial resolution (pixels), with 8-bit signal resolution; (2) High signal-to-noise ratio; (3) High speed gating (approximately 64 nanoseconds) using an external trigger; and (4) A programmed number of accumulated low-light images can be used to give one usable image. By increasing the number of exposures, or accumulated images, the investigator can then use the average intensity per exposure to compute the normalized value of intensity. This, in effect, allows the range of the 8-bit resolution to be adjusted to accommodate orders-of-magnitude changes in intensity. In the present investigation, all calibration data were acquired using the same gate speed and the same number of exposures per image. The final images were the average of ten images.

A. NPS CALIBRATION SETUP

1. NPS Calibration Setup

The experiment was conducted in the Gas Dynamics Laboratory (Bldg. 216) at the Naval Postgraduate School. The experimental setup is shown in Figure 3. The main components included: an image acquisition System; an Oriel 1000 Watt quartz-tungsten halogen lamp with Oriel lamp controller; a calibration pressure chamber; a vacuum pump; a compressed-

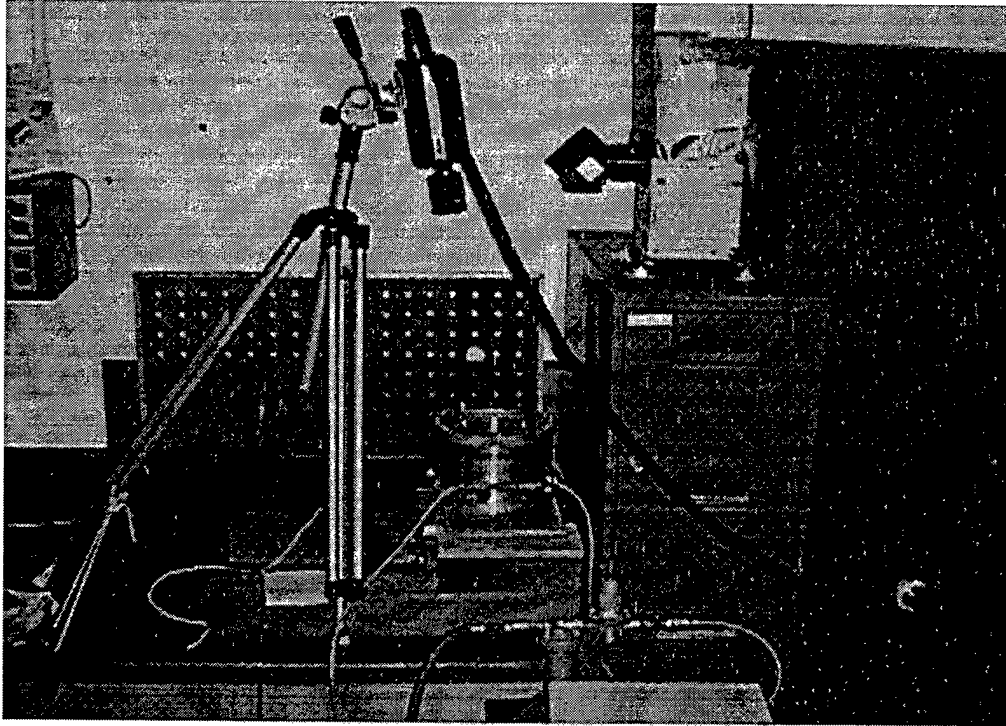

Figure 3. NPS PSP Calibration Experimental Setup

air source, and a hot plate. The image acquisition system shown in Figure 4 is extensively documented in previous theses by Quinn, Gahagan, and Varner [Refs. 3, 6, 13]. The calibration pressure chamber, described by Varner [Ref. 13] and shown in Figure 5, was mounted on blocks of aluminum on top of a hot plate. An Omega model HH21 microprocessor thermometer, using a type J thermocouple and connector, was used to measure the temperature of the test coupon, which was placed inside of the calibration pressure chamber. Independent valves isolated a vacuum pump line and a compressed air line from the chamber. A common threaded fitting, mated with the chamber, allowed the thermocouple wire and pressure sensing line to enter the chamber. The pressure sensing line was connected to a Heise pressure gage. The UV illumination source was fitted with an Oriel blue-gel and Interference filter (Model #66228 and #575 respectively), which provided illumination with the wavelength centered at 380nm. The lamp was supplied with AC voltage via an Oriel

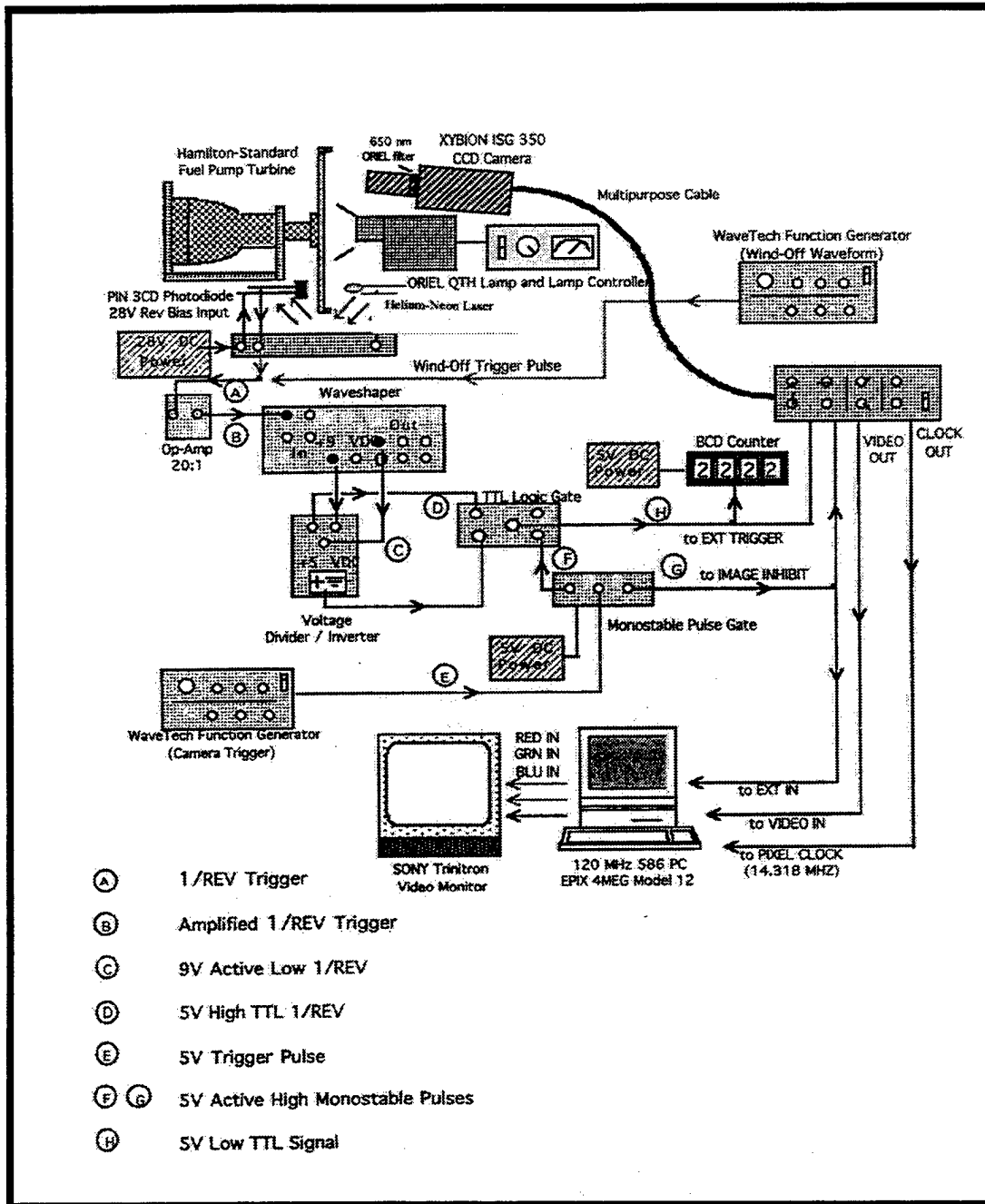

Figure 4. Image Acquisition System From Quinn [Ref. 3]

lamp controller, Model #6405-M. The control voltage was adjusted to 118% of line voltage to ensure ample illumination on the sample. The lamp source was offset at the top of the coupon, in order to reduce glare from reflections on the chamber window. The reflection was eventually reduced to a small "sun spot" area at the very top of the image.

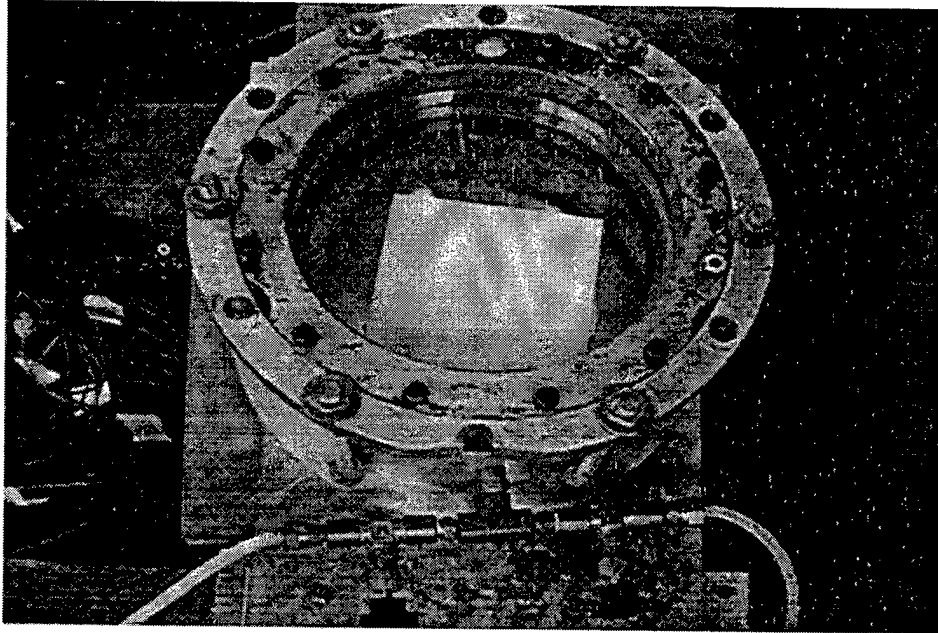

Figure 5. Calibration Pressure Chamber with Vacuum and Pressure Line

A Xybion camera control unit (CCU) controlled the Xybion ISG 350 Intensified CDD-video camera. The camera was fitted with a 75 mm C1.4 Cosmocar™ television lens and an Oriel interference filter (Model #53590) to limit the camera's spectral response to the desired 650nm wavelength. The timing diagram for the camera control is shown from Quinn [Ref. 3] in Figure 6. The CCU was adjusted to the same settings as were required for rotor images at 20,000 rpm (333 Hz), as reported in Gahagan [Ref. 6], except that the image inhibit signal was adjusted to 10.3 sec, instead of 8.0 sec. The acquisition was identical to the acquisition of "wind-off" images using a Wavetech signal generator to provide the equivalent of a one-per-revolution signal. Ten acquired images were averaged to produce the final image.

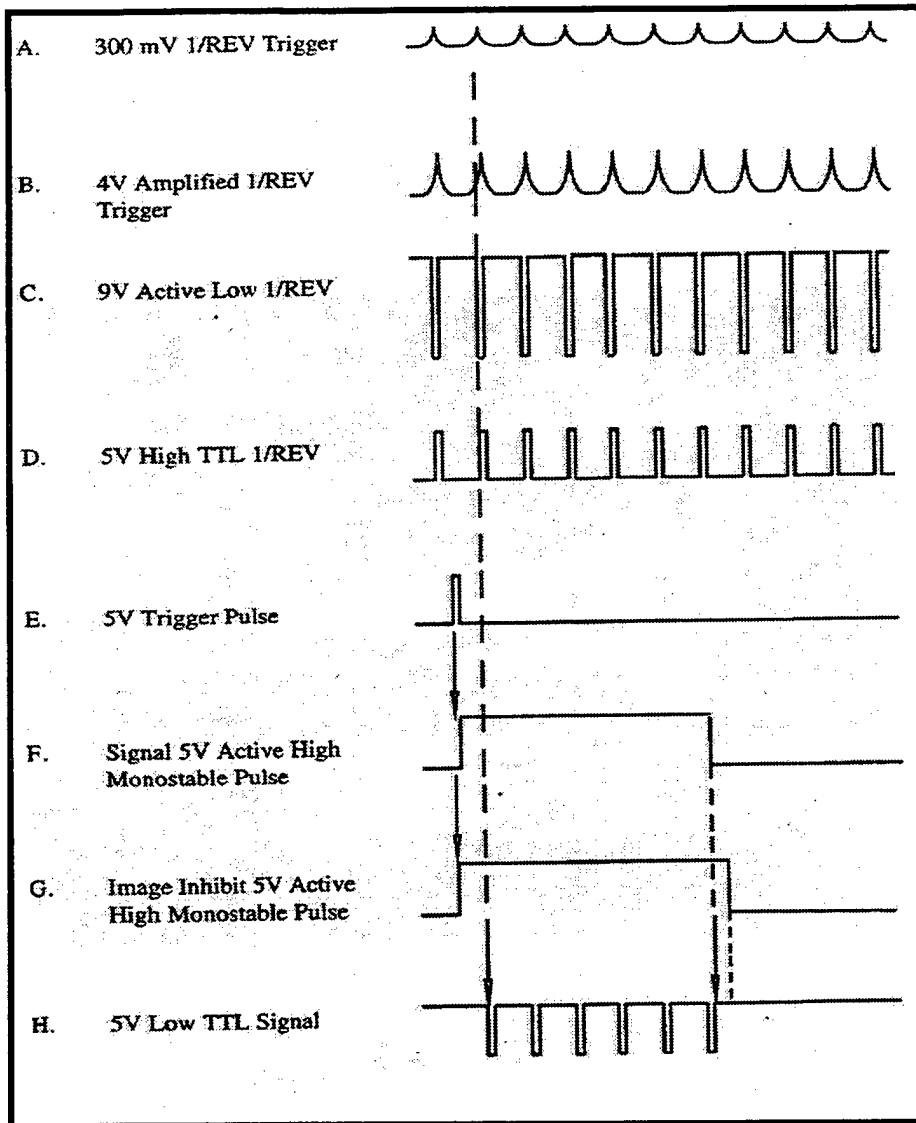

Figure 6. Image Capture Timing Sequence From Quinn [Ref. 3]

All test coupons measured about 4 inches by 4 inches by 1/8 inch thick, and were cut from 6061-T6 aluminum sheet. The aluminum coupons were painted with an initial coat of glossy white interior/exterior Krylon (#1501) paint. PSP was then airbrushed onto the surface after the Krylon paint had dried. An alcohol-based shellac, Bulls Eye (Product #0408), manufactured by Zinsser, and was then sprayed over the right half of the coupon. The layer of shellac separated the coupon into 2 vertical

test areas, the left half was straight PSP and the right half was shellac-coated PSP.

2. Test Conditions and Procedures

Three calibration test series were completed. The first was conducted at constant-temperature, variable-pressure. The test conditions are shown in Table 1. The second series was conducted at constant-pressure, variable-temperature. The test conditions are shown in Table 2. The third series was a simple ambient temperature and pressure, time deterioration test. The test conditions are given in Table 3. This time deterioration test was performed to establish the paint degradation characteristic at constant ambient conditions. For all three test series, the thermocouple was fixed to the under surface of the coupon with duct tape, and the coupon was placed in the calibration pressure chamber. The chamber was positioned so that the top center of the coupon split the lamp illumination beam in equal halves. During constant-temperature, variable-pressure tests, an ambient atmospheric pressure and temperature image was recorded, followed by low pressure points, by adjusting vacuum. Then high pressure points were taken by controlling the supplied pressure. The atmospheric reference point (I_0) was repeated as the pressure was increased. A dark-current image was taken at the end of each data series. In the constant-pressure, variable-temperature series, an atmospheric temperature image was recorded first at the test pressure. The hot plate was then turned on, causing a continuous increase in temperature. Test images were recorded at the specified test temperatures. Cool-down, post-run test points at atmospheric temperature and test pressure were not recorded because 10-12 hours were found to be required for the chamber to cool down.

Table 1. Constant-Temperature, Variable-Pressure Test Conditions

Run Name	Fresh/Used	Number of Points	UV On (min)	Pressure Range (psi)	No. of Ambient Pressure Points	Nominal Temperature (° F)	Temperature Range (° F)
AC0	Fresh	10	44	0.5-17.3	2	73	71.6-73.1
AC1	Fresh	10	47	0.5-17.4	2	100	96.9-99.6
AC3	Fresh	10	30	0.5-17.5	2	120	116-124.0
AC4	Fresh	10	43	0.5-17.6	2	100	97.8-104
AC5	Used	10	27	0.5-17.7	1	72	71-72.7
AC6	Fresh	12	44	0.5-25.0	2	73	71.7-73.7
AC7	Used(50min)	12	36	0.5-25.0	2	125	117-128.9
AC8	Fresh	12	33	0.5-25.0	2	125	116.8-128.9
AC9	Fresh	12	33	0.5-25.0	1	100	98.5-106
AC1	Used(50min)	12	33	0.5-25.0	2	85	81.1-86.8

Table 2. Constant-Pressure, Variable-Temperature Test Conditions

Run Name	Fresh/used	Number of Points	UV On (min)	Nominal Pressure (psi)	Ambient Temperature (° F)	Temperature Range (° F)
BC1	Fresh	11	34	14.8	74.7	74.7-145.0
BC2	Fresh	7	25	0.5	71.7	71.7-145.0
BC4	Fresh	9	24	25	71.9	153.3

Table 3. Time Deterioration Test Conditions

Run Name	Fresh/used	Number of Points	UV On (min)	Nominal Pressure (psi)	Ambient Temperature (° F)	Temperature Range (° F)
BC3	Fresh	9	65	14.8	80	78.1-82.9

3. Data Acquisition and Reduction

a. Data Acquisition

For each test point the elapsed time, test temperature and pressure were recorded. During constant-pressure, variable-temperature tests, temperatures were recorded at the start and during the acquisition of images 1,2,4,6, 9, and 10. The acquisition of each image, prior to being stored in the image buffer, took approximately 10.3 sec. The average temperature or pressure for a particular data point was recorded. Except where noted in Tables 1, 2, and 3, all tests were completed within a total 35 minutes after switching on the UV lamp.

b. Data Reduction

Initial Data Reduction: All data points presented in Tables 1, 2, and 3 were recorded and saved using the EPIX 4 MEG Video Model 12 integrated circuit board and EPIX 4MIP V3.2 software. The image data acquired with this frame grabber hardware and software were installed in a 120 MHz Pentium personal computer [Ref. 6]. Software scripts were developed by Quinn [Ref. 3] to make the image acquisition process automatic. Ten images were captured for each data point and a dark current image was acquired for each data series. The images were then processed by first subtracting the dark current image and then ratioing the image at each data point to the image at the reference condition for the series of points. The constant-temperature, variable-pressure tests utilized the second ambient pressure condition as the reference. The constant-pressure, variable-temperature tests utilized the initial ambient temperature image as the reference, since the cool down ambient temperature test points could not be obtained.

Post Processing Data Reduction: The ratioed images (test condition ratioed to reference condition) were individually processed using the EPIX software to obtain the 'y-mean', average value (vertical column of pixels) of I_0/I values. The majority of the individual pixel values were similar in magnitude and low (< 100) out of a scale of 0-255, whereas noise appearing at individual pixels had very high values (>200). The noise that was introduced during the video capture required a manual smoothing technique, which rejected bad pixel values. The rejections of erroneous pixel values within the 'y-mean' vertical column (0-479) was based on the rejection criteria shown in Table 4. Common pixel coordinates were chosen as a location at which to define the sample

Table 4. Pixel Noise Rejection Criteria

Initial Y-Mean Pixel Value	Rejection Criteria Pixel Value
0-20	>100
20-100	>200
100-200	255

intensity. Two different specific pixel positions were chosen for the PSP and shellac-coated PSP intensities. One pixel position on the left side of the coupon was selected for the shellac-coated PSP (x-100, y-256). One pixel position on the right side of the coupon was selected for the shellac-coated PSP (x-550, y-256). For the constant-pressure, variable-temperature PSP test series, only one common pixel coordinate was required (x-100, y-256). The 'y-mean' value, which is the mean value of the vertical column (0-479 pixels) at the selected value of x was calculated using the EPIX software to provide a representative average intensity for the measured sample temperature. The 'y-mean' values at the selected x positions were recorded. Subsequent to image processing through the EPIX software, corrected 'y-mean' values were computed off-line to eliminate the noise introduced by the inclusion of 'saturated' pixels. The 'y-mean' values were corrected using the following equation:

$$\text{Corrected Average (y-mean)} = \frac{(N * X - (n * R))}{N - n} \quad (2)$$

where: N=479(total vertical pixels)

X=average of N pixels (original y-mean)

n=number of rejected pixels

R=Rejected pixel value

Data from the constant-pressure, variable-temperature tests shown in Table 2, did not require manual post-processing to eliminate noise. The corrected constant-temperature, variable-pressure data from tests in Table 1 are given in Appendix C.1, Tables C1 through C5. After corrections, some data points were rejected entirely from the data set because of unusually high noise. The data points rejected for high noise are shown in Appendix C2, Table C6 through C10. The manual image processing used to correct for noise was only applied to data runs AC-5 through AC-10. Several of the data points in the time deterioration data series shown in Table 3, had to be rejected due to excessive noise levels. The data are given in Appendix B3, Table B14.

B. NASA-AMES RESEARCH CENTER CALIBRATION

1. NASA Calibration Setup

NASA-Ames Research Center is actively involved in the use of several PSP and TSP formulations. Most of their testing with PSP to date has involved investigations of pressure distributions on aerodynamic models in wind tunnels. Most recently, research has been expanded to study unsteady flow characteristics on scaled helicopter rotor blades [Ref. 14]. A PSP bench-top calibration apparatus for PSP, which was developed at Ames and was used to calibrate coupons provided by NPS, is shown in Figure 7. The system provided a computer-controlled automatic calibration procedure. The test coupons used measured about 1.3 inches

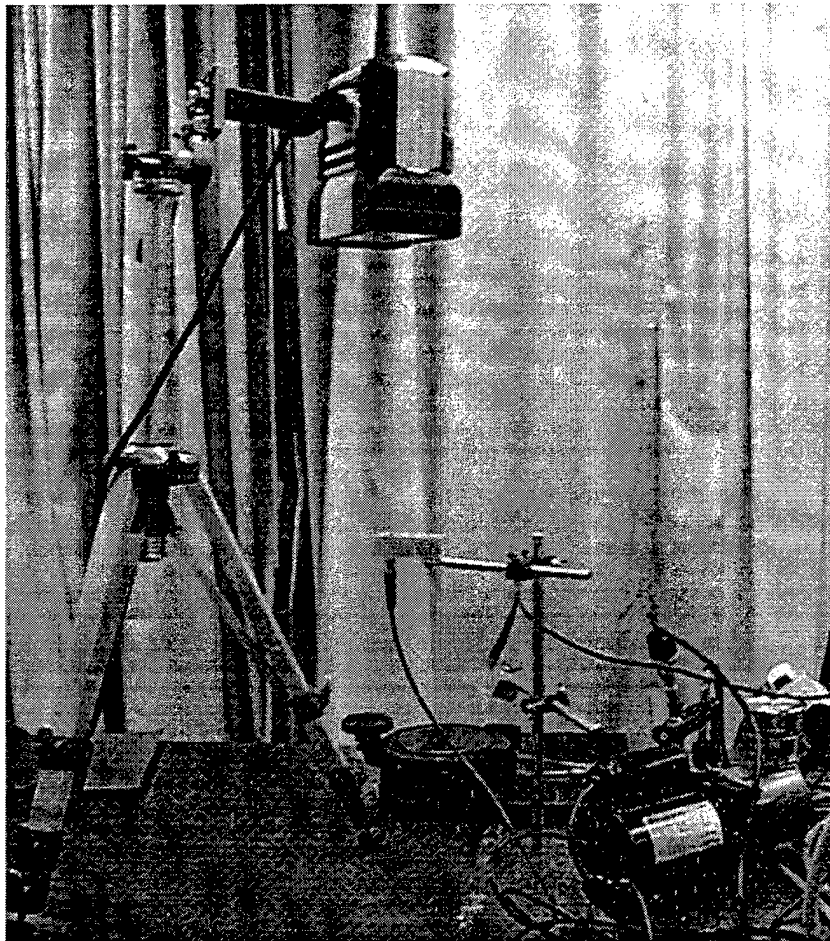

Figure 7. NASA-Ames PSP Calibration Apparatus

by 1.3 inches by 0.13 inches thick, and were cut from 6061-T6 aluminum sheet. The test coupons were prepared in exactly the same way as the coupons for the NPS calibration tests, except that shellac-covered PSP coupons were prepared as separate samples. The test coupons were placed in the test chamber. Temperature was controlled by a piezo-electrically controlled crystal (Peltier-cooling), using a temperature sensor and LabviewTM software. Pressure was controlled using electronically controlled valves connected to a vacuum pump, a compressor air source and a Mensor CPS 4000 Pressure Calibration System, shown in Figure 8. All chamber pressure lines contained dryer elements to eliminate humidity



Figure 8. Mensor CPS 4000 Pressure Calibration System

effects. Both the illumination source, a ELC-250 UV Longwave (356nm) Arc Lamp with power supply, and the light emissions from the coupon in the pressure chamber, were continuously monitored by separate photodiodes. One photodiode faced toward the illumination source to monitor fluctuations in light intensity. A second photodiode was positioned above the test coupon in the pressure chamber. In the initial step in the calibration procedure, the photodiode sensing the light emissions from the coupon in the pressure chamber was adjusted vertically to ensure that the test condition intensities (from brightest to darkest) were within the photodiode measurement range.

2. Tests and Test Conditions

The test conditions for the NASA-Ames calibration tests are shown in Table 5. The data obtained are given in Appendix D, Table D1 through D9.

Table 5. NASA-Ames Calibration Test Conditions

Run Name	Fresh/Used	PSP/Shellac	Number of Points	UV On (min)	Pressure Range (psi)	Target Temperature (° F)
C-1	Fresh	PSP	12	44	0.2-14.8	68
C-2	Fresh	PSP	12	44	0.2-14.8	68
C-3	Fresh	Shellac	12	44	0.2-14.8	38
C-4	Fresh	Shellac	12	44	0.2-14.8	68
C-5	Used(30min)	Shellac	12	44	0.2-14.8	53
C-6	Fresh	PSP	12	44	0.2-14.8	38
C-7	Used(50min)	PSP	12	44	0.2-14.8	53
C-8	Fresh	PSP	12	44	0.2-14.8	68
C-9	Fresh	Shellac	12	44	0.2-14.8	68

3. Data Acquisition and Reduction

Entries were made to the Labview™ software to obtain the desired test temperature/pressure profile. The test had been pre-programmed to always take the lowest pressure data point first in order to eliminate any humidity that may have entered the system when opening the calibration chamber. The test profile followed a random data point selection process. The investigator entered the required range of pressures and temperatures, and the total number of data points, and the Labview™ software then randomly selected the order in which the data points were taken. The Labview™ program adjusted the pressure (controlled through the Mensor Pressure Calibration System) to obtain the required pressure magnitude before data acquisition could begin. The photodiode intensity levels, temperature, and pressure values were stored in a Labview™ spreadsheet. The Labview™ software automatically calculated the ratio I_o/I and several other parameters not required in the present investigation. The data obtained at NASA-Ames are given in Appendix D, Tables D1 through D9. The PSP data for 3 temperatures (38°, 53°, and 68° F) are shown plotted in Appendix D, Figures D1, D2 and D3, respectively. The NASA-Ames calibration data were exported to a Microsoft Excel™ spreadsheet for analysis.

IV. RESULTS AND DISCUSSION

A. CONSTANT-TEMPERATURE, VARIABLE-PRESSURE RESULTS

Ten test runs were completed at NPS using the constant-temperature, variable-pressure calibration procedure. The data obtained are given in Appendix B.1. However, the temperature could not be automatically controlled and therefore, temperature varied somewhat during each test, as shown in Table 4. After corrections were made for noise, using off-line processing, five tests in which temperature was held reasonably well throughout and no other inconsistencies appeared, were selected for further analysis. These data are reported in Appendix C.1. When the data in Appendix C.1 were plotted, obvious inconsistencies were identified which, when the original image intensity values were examined, were clearly explained by spurious noise during image acquisition. Such data points were eliminated from the data set, leaving the data given in Appendix C.2. Plots of the retained data are given in Appendix C.3. Only data plotted in Appendix C.3 will be discussed further.

The PSP data shown in Appendix C.3, Figures C1 through C5 cover a range of temperature from room temperature to 153° F and a range of pressures from near zero to 1.7 atmospheres. It is clear that, despite attempts to eliminate noise, the data are not sufficiently smooth to determine an analytic representation that can be used as a calibration of the paint. It is also clear that there is some curvature to the behavior. While a linear fit may be appropriate for data at room temperature below 1 atmosphere, it is not appropriate over the full range of pressures and temperatures.

In contrast, the data obtained in the NASA calibration chamber, shown plotted in Appendix D, Figures D1, D2, and D3 are extremely

smooth, and could certainly be used to derive an analytical representation for calibration purposes. It is immediately clear, however, that the best representation would be non-linear, and the coefficients would depend (slightly) on temperature. Unfortunately, the NASA tests were at room temperature and below, whereas the NPS tests were at room temperature and above, and room temperature at NASA was 4° F lower than at NPS. (For the desired transonic compressor application, the temperature range above room temperature is required).

Composite plots of the NASA data and the corrected NPS are shown plotted in Figures 9, and 10. In Figure 9, a least-squares linear curve was fitted to each data set. It is of interest that the linear curve fits to the NPS corrected data and the NASA-Ames calibration data produced an increasing slope with increasing temperature. This is consistent with the published results shown in Figure 2. The two calibration data sets, using different calibration methods were consistent with one another. Quadratic curve fits to the same data are shown in Figure 10. The NASA-Ames data were consistent in giving an increasingly negative quadratic term with increasing temperature. The NPS data were not consistent with respect to the magnitudes of the polynomial coefficients with increasing temperature, and this could easily be due to the scatter in the data.

B. EFFECTS OF SHELLAC COATING ON PSP RESPONSE

Ten test runs were completed using shellac coating over half of the PSP test coupon in the constant-temperature, variable-pressure calibration tests. The post-processing correction technique was used to smooth the data from the shellaced surface. An extreme data scatter was observed nevertheless in the early results, and time-dependence was suspected because of the possibility of slow oxygen diffusion through the shellac. When additional time was allowed for the shellac-coated samples, from which the data are shown in Appendix C.3, Figures C3 through C5, the

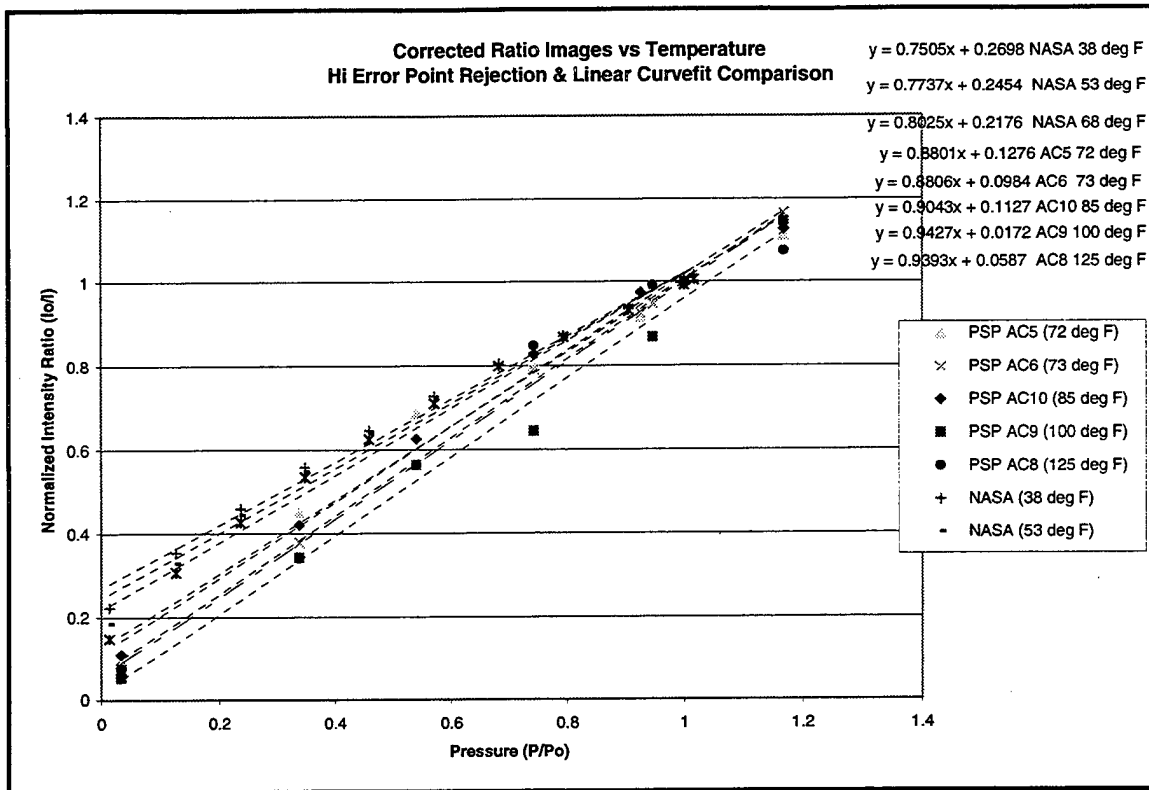

Figure 9. NPS and NASA Calibration Data with Linear Curves Fitted

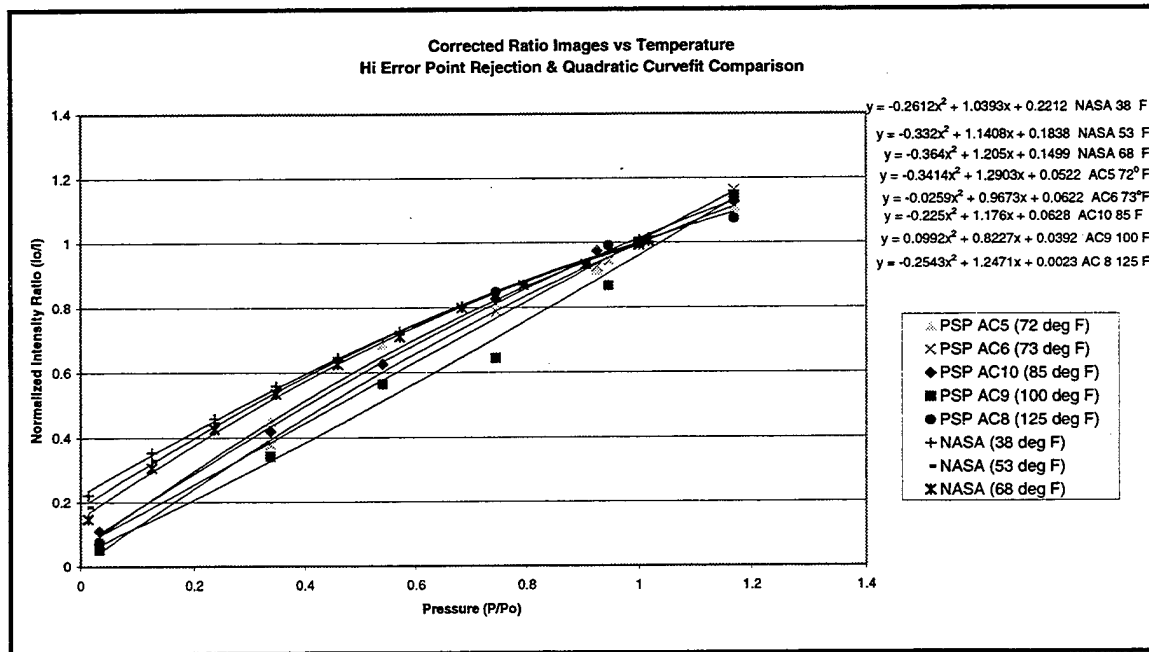

Figure 10. NPS and NASA Calibration Data with Quadratic Curves Fitted

shellac-coated PSP intensity approached the uncoated PSP intensity. The shellac-coated PSP results were not repeatable. There was always some data scatter when relatively long times were allowed for oxygen to diffuse through the shellac coating. As a result, the shellac-coated PSP was not considered to be useful. It was neither insensitive to pressure, nor did it yield a consistently different response to temperature and pressure when compared to uncoated PSP. It was, therefore, unsuitable to be used in a process to calculate the temperature and pressure on a rotor using the technique given in Appendix A.

C. CONSTANT PRESSURE, VARIABLE TEMPERATURE RESULTS

Three tests using a constant-pressure, variable-temperature calibration procedure were conducted. Pressure was easily maintained within 0.05 psi, and the temperature was varied over ranges which are given in Table 5. Corrections for noise were not required for data obtained in these tests. The data are given in Appendix B.2, Figures B11 through B13, for constant pressure levels of 0.5 psi, 14.8 psi and 25.0 psi, respectively. The data are shown plotted in Figure 11, using a semi-log scale. Notice that for each pressure level, the same common value of I_0 at 14.8 psi and room temperature was used as the reference intensity. The plot, therefore, shows the full range of intensity variation, which was measured, as temperature and pressure were varied. The curves shown are quadratic curve fits to each data set. While not evidenced in the semi-log plot, the response of the PSP (PtOEP) appeared to be almost linear (at constant pressure) in the range of temperatures between 70° and 100° F, but non-linear at temperatures greater than 100° F, for all three pressures tested. The leveling off in intensities at temperatures greater than 120° F for pressures at or above ambient pressure suggest the image system had

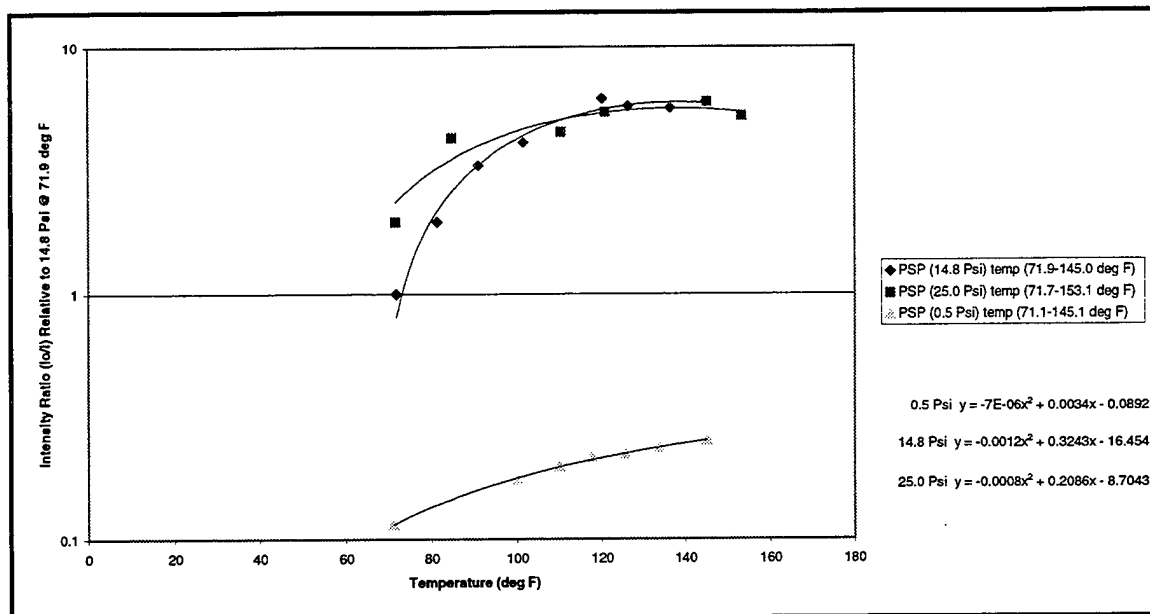

Figure 11. Constant-Pressure, Varing-Temperature Results (I_0 at 14.8 psi and 71.9° F)

reached a minimum intensity threshold. Based upon these observations, PtOEP would not be an attractive choice for applications in turbomachinery. However, by changing the number of integrated images, (the gate duration of the intensified CCD camera is set to limit image blur), the image acquisition system can be adjusted to accommodate the very low intensity ranges. Data from tests, in which the 'wind-off' reference image was acquired with a different number of exposures than the 'wind-on' image, would be reduced by ratioing values of intensity per exposure. The variation of intensity with temperature at elevated pressures (25 psi) was compared with data (at 28 psi) published by Woodmansee [Ref. 8]. The comparison is shown in Figure 12. Again, the Woodmansee data [Ref. 8] were taken at room temperature, and below, whereas the NPS data were taken at room temperature and above. In Figure 12, the Woodmansee data [Ref. 8] are shown normalized to the intensity measured at room temperature, to be compared on a consistent basis with the NPS data. The trends are seen to be consistent, but more

complete data are required to confirm the decreasing sensitivity at increased temperatures.

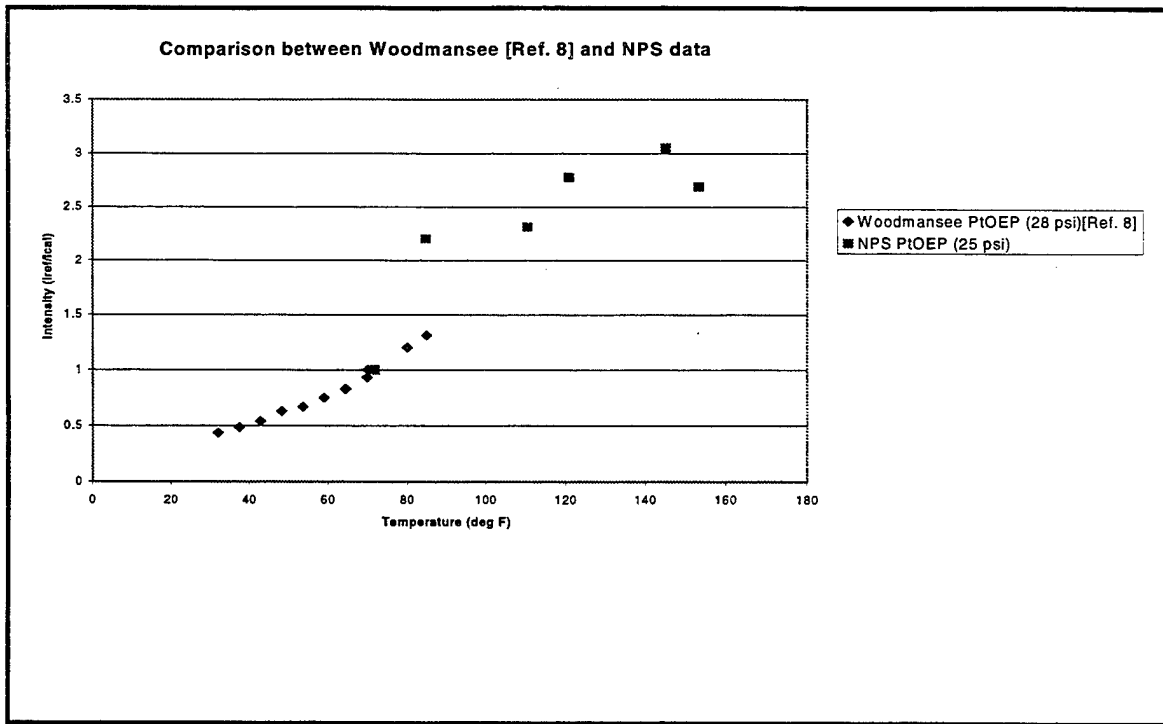

Figure 12. Comparison of Woodmansee Data with NPS Data

D. TIME DETERIORATION TEST RESULTS

One calibration test was conducted in order to determine the deterioration in output as a function of time. The test was conducted at constant ambient temperature and pressure (80° F and 14.8 psi). The results are shown plotted in Figure 13. The response of the PSP (PtOEP) under continuous UV illumination appears to fall off slowly over the first 50 minutes, with very little photodegradation. The response then appears to decrease rapidly. Based upon these results, it was concluded that maximum errors of 2-5% would be expected if data were taken in the first 35 minutes. The majority of the calibration test runs (both constant-

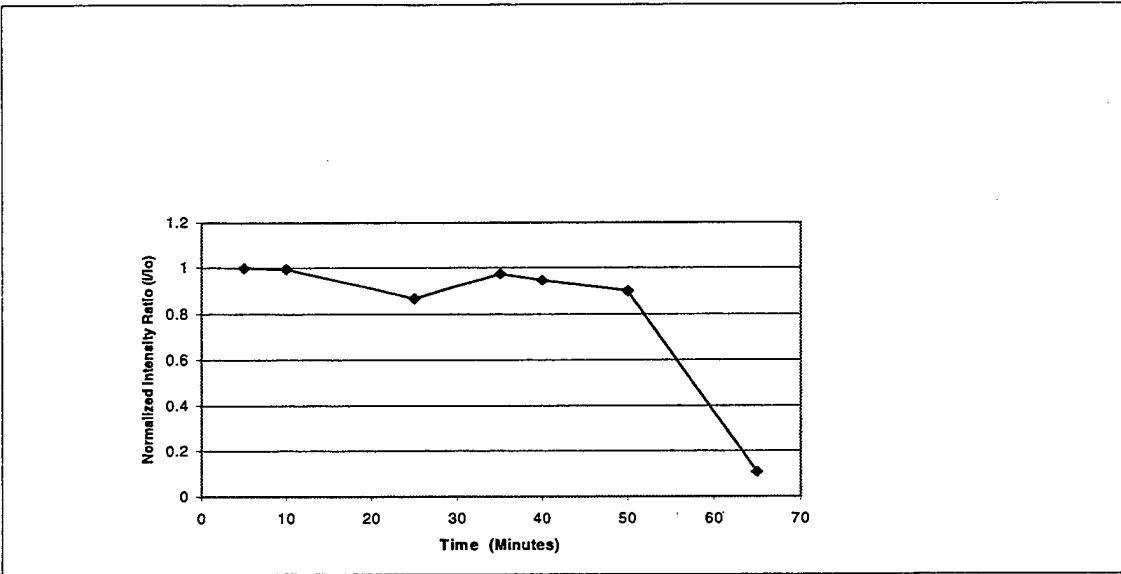

Figure 13. Time Deterioration Calibration Test Results

temperature, variable-pressure and constant-pressure, variable-temperature) were completed within 35 minutes. The exceptions are noted in the test conditions given in Tables 1 and 2. Several calibration tests were conducted using the PSP sample coupon for a second time. The calibration characteristics obtained (I_o/I vs P/P_o) were repeated reasonably well, however, the reference intensity obtained at the start of the second test was considerably lower than at the start of the first test. The effects of heat on photodegradation of the PSP needs to be investigated by conducting tests at higher temperatures.

E. REPEATABILITY

Several of the constant-temperature, variable-pressure calibration tests were repeated. A comparison of two runs at room temperature (73° and 72° F) are shown in Figure 14.

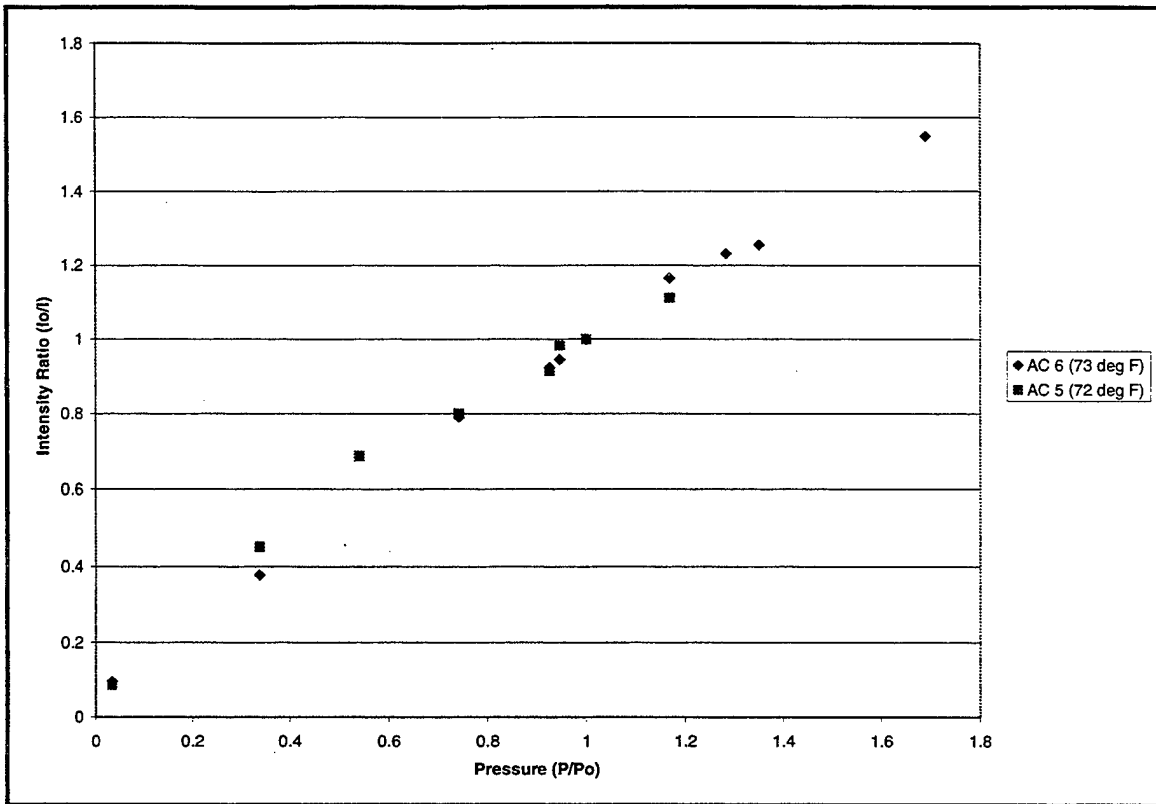

Figure 14. NPS Constant-Temperature, Variable-Pressure Repeatability (72°-73° F)

A comparison of two heated tests (at 100° F-125° F) are given in Figure 15. Repeatability is seen to be within the scatter of the data points within each set, particularly at the low pressure points and the high pressure points. The largest departures are observed just below the atmospheric pressure ($I_o/I=1$ and $P/P_o=1$) reference condition, and no explanation was found for this occurrence.

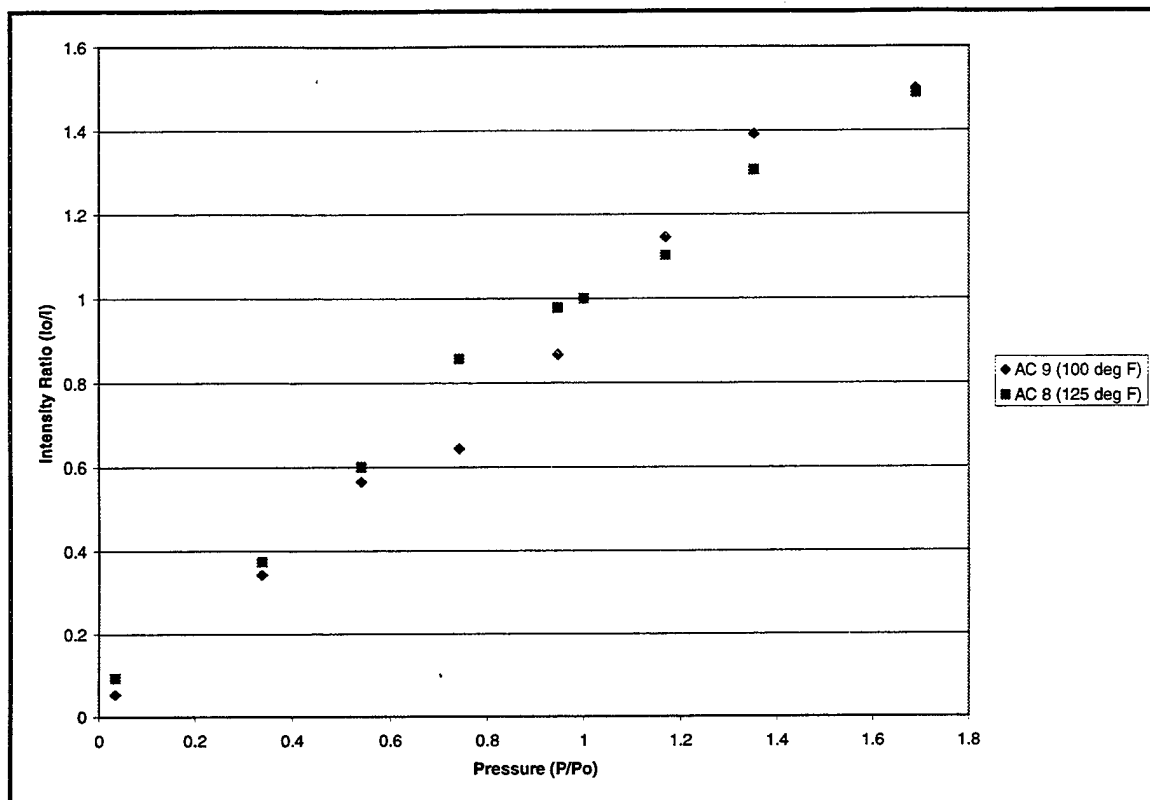

Figure 15. NPS Constant-Temperature, Variable-Pressure Repeatability (100°–125° F)

V. CONCLUSIONS AND RECOMMENDATIONS

A. CONCLUSIONS

Calibration measurements were carried out in two different laboratories, using different chambers, different illumination and intensity measurement systems, to examine the temperature, as well as the pressure response of PSP. The following conclusions were drawn:

1. While the NPS results were of lower quality than NASA-Ames results, and there was no overlap in test conditions, the two data sets were consistent with one another. At constant temperature the average slope of the (I_o/I) vs (P/P_o) characteristics increased steadily with temperature from 38° F to 125° F, and some curvature was clearly present. Therefore, while not proven by the results, the 'a priori' approach to using PSP is not brought into question, and good analytic approximations of calibration data should be possible.
2. The contrast in quality between the two experiments showed clearly what must be done to obtain accurate calibration data, and consequently, what must be done to obtain accurate quantitative data from an application of PSP. In the calibration procedure, temperature and pressure must be precisely controlled and measured, whereas they must be determined in the application. A requirement that is present in both the calibration and the application is to monitor the intensity of the excitation source, and, if it is not constant, to correct for variations. This was not done in the NPS calibration experiments, and may explain much of the scatter in the data.
3. The calibration data at pressures above one atmosphere appeared to be consistent with published results, but the data did not overlap. The sensitivity to temperature change decreased as pressure was

increased, with no sensitivity to temperature detected above about 120° F. This result needs to be reexamined; however, since the absolute luminescent intensity decreased by a factor of about 6.5 from room temperature and 0.5 psia to 150° F and 25 psia, and the ability to resolve very low intensity levels accurately must be questioned.

4. An analysis has shown that, in principle, pressure and temperature can be obtained from PSP measurements on a rotor if paints with different sensitivities can be applied to two different rotor blades. The simplest option is to create pressure insensitivity by sealing the PSP altogether from oxygen. The attempt made in the present study to seal the PtOEP using shellac was not successful. The response became highly time-dependent, suggesting oxygen diffusion was occurring slowly through the shellac. The procedure and shellac evaluated here were not useable.

5. The test rotor was operated successfully to 30,000 rpm, reliable rpm readout was obtained, and no stripping of the paint was experienced.

B. RECOMMENDATIONS

The following recommendations are made in order of importance:

1. Set-up an automated calibration procedure similar to that at NASA-Ames, but using a heater in place of the cooler and with pressure control provided up to two atmospheres.
2. In all future measurements, use a procedure in which luminescent intensity is referred to lamp intensity measured by a photodiode.
3. In future measurements using the gated CCD camera, adjust the number of gated exposures so that the accumulated image intensity is always large, compared to all sources of noise. This will require

a different number of exposures for 'wind-on' and reference conditions. The intensity ratio can be evaluated by calculating the intensity-per-exposure for each image. This has the effect of moving the resolution of the 8-bit camera over several orders of magnitude change in intensity. Note that this does resolve the problem of maintaining accuracy over a broad range of intensity change occurring in the calibration process. However, the ability to resolve a range of intensity change over an image field remains. This might be overcome, however, by acquiring more than one accumulated image with different numbers of exposures. Again, the intensity ratio would be evaluated on the basis of intensity per exposure, using different images to evaluate different areas of the image field.

4. Examine other PSP formulations and choose the paint that is most suited to the intended transonic compressor application. The selected paint should have repeatable behavior to temperatures up to 120° F and show less photodegradation than PtOEP.
5. Examine alternative solutions to sealing PSP to oxygen to obtain a 'second-paint'. If consultations with developers of paints are not fruitful, design a procedure to use two paints with different luminescent frequencies, requiring different filters, but possibly using one camera.
6. Fully investigate and analytically characterize the selected paint using the calibration set-up, then verify the 2-paint technique using the test rotor.

APPENDIX A. ANALYTICAL FRAMEWORK FOR THE CALIBRATION AND APPLICATION OF PSP

Analytical framework for the calibration and application of PSP was taken from Shreeve [Ref. 7].

If it is recognized that PSP is both pressure and temperature sensitive, in principle it is possible to extract both pressure and temperature if measurements are made using *two paints* having different sensitivities to temperature and pressure. Clearly, making one of the paints totally insensitive to pressure, by sealing from oxygen, is a special case, but one that would allow the use of the same camera and filter system for both images. The use of Temperature Sensitive Paint (TSP) for the second image would require a separate camera/filter to accommodate a second luminescent frequency.

The PSP response must be represented analytically in terms of pressure and temperature. In Seivwright [Ref. 15], the Stern-Volmer equation is written

$$\frac{I_0}{I} = A'(T) + B'(T)\left(\frac{P}{P_0}\right) \quad (1)$$

where the coefficients A' and B' are functions of temperature and I_0 and I would have to be taken at the same temperature to be able to determine P/P_0 from 'wind-on' and 'wind-off' images. (I_0 and P_0 are the reference luminescent intensities and reference pressure, respectively, and P and I are the measured intensity and pressure at the experimental condition).

In equation (1),

$$A' + B' = 1 \quad (2)$$

The Stern-Volmer equation is a first-order representation of the PSP behavior. Calibration experiments show a slightly non-linear behavior, and therefore a representation such as,

$$\frac{P}{P_o} = A + B\left(\frac{I_o}{I}\right) + C\left(\frac{I_o}{I}\right)^2 \quad (3)$$

is assumed, where $A=A(T)$, $B=B(T)$, $C=C(T)$ and, because of the definition of I_o ,

$$A + B + C = 1 \quad (4)$$

In equation (3), the coefficients depend on temperature and I_o and I must be taken at the same temperature to determine (P/P_o) from wind-on and wind-off images. Since this is not the case in practice, the calibration must be represented so that this difference is accounted for. It is assumed that $P_o=1$ atmosphere, then the temperature dependence of I_o can be expressed as

$$\frac{I_o(T_o)}{I_o(T_{ref})} = F_I\left(\frac{T_o}{T_{ref}}\right) = \left(a_I + b_I\left(\frac{T_o}{T_{ref}}\right) + c_I\left(\frac{T_o}{T_{ref}}\right)^2\right) \quad (5)$$

and the coefficients in equation (5), must be established by calibration. Taking $T_{ref} = T_{STP} (=67.8^\circ \text{ F})$, the temperature dependence of A , B , and C can be written as

$$\frac{A(T)}{A(T_{ref})} = F_A\left(\frac{T}{T_{ref}}\right) = \left(a_A + b_A\left(\frac{T}{T_{ref}}\right) + c_A\left(\frac{T}{T_{ref}}\right)^2\right) \quad (6)$$

$$\frac{B(T)}{B(T_{ref})} = F_B \left(\frac{T}{T_{ref}} \right) \left(= a_B + b_B \left(\frac{T}{T_{ref}} \right) + c_B \left(\frac{T}{T_{ref}} \right)^2 \right) \quad (7)$$

and, always

$$C = 1 - A - B \quad (8)$$

In an application of PSP, an image is acquired at an unknown paint temperature, T, and paint pressure, P; this is "wind-on". An image is then acquired at (close to) one atmosphere, P_o, and an unknown temperature, T_o; this is "wind-off". If T_o & T were known, F_A and F_B could be determined from equation (6) and equation (7) and then P/P_o would be given by

$$\frac{P}{P_o} = A(T_{ref}) \cdot F_A + B(T_{ref}) \cdot F_B \cdot \left[\frac{I_o(T_o)}{I(T)} \frac{I_o(T)}{I_o(T_o)} \right] + C(T) \cdot \left[\frac{I_o(T_o)}{I(T)} \frac{I_o(T)}{I_o(T_o)} \right]^2 \quad (9)$$

where $\frac{I_o(T_o)}{I(T)}$ is given (at each pixel) by the ratioed images, and using equation (5) twice,

$$\frac{I_o(T)}{I_o(T_o)} = \frac{F_I \left(\frac{T}{T_{ref}} \right)}{F_I \left(\frac{T_o}{T_{ref}} \right)} \quad (10)$$

Alternatively, equation (9) can be viewed as one equation with unknowns, P/P_o, T/T_{ref}, T_o/T_{ref}.

With two different paints, two equations are obtained, but with 3 unknowns.

The problem is solved (P & T can be determined) if

- a) T_o is known and 2 paints with different sensitivities are used, or
- b) T_o and T are known, and one paint is used.

It is also required that the coefficients in F_A , F_B , and F_I be established by calibration. Also, note that the data reduction procedure must be carried out for each pixel. The key question here is whether a calibration carried out in a calibration chamber (perhaps with a photodiode compared to a CCD camera) will yield the same calibration coefficients for the dependence

$$\frac{I_o}{I} = \frac{I_o}{I} \left(\frac{P}{P_o}, \frac{T}{T_{ref}} \right) \quad (11)$$

Clearly, the coefficients established would be correct if the calibration could be carried out "in-situ, prior" (requiring the compressor test rig to be set up so that vacuum could be applied, and several temperatures held, using an identical arrangement of apparatus and CCD camera to that used in the pressure measurement). This is very difficult to do in most (established) facilities. If

- a) "a priori" chamber calibration \neq "in-situ prior" calibration
- b) "in-situ, prior" calibration can not be implemented,

then a technique for "in-situ" calibration is absolutely necessary.

[Note: This is what was done for pressure measurements using Kulite transducers, which were also temperature dependent [Ref. 16]. In that case a separate measurement of time-averaged stagnation pressure, and (effectively) static pressure were set equal to the same quantities given by the 2-Kulite probe system. This allowed the unsteady pressures to be determined.]

Potential "in-situ" calibration methods include

- a) Use infrared temperature measurements and CFD results for pressure level at 'specific' locations (selected for low uncertainty).
- b) Acquire PSP data from stationary surfaces, which are instrumented for temperature and pressure (case-wall, or fin, or stator blade).

APPENDIX B. CAPTURED IMAGE DATA (RAW IMAGE DATA)

**B.1 CONSTANT-TEMPERATURE, VARIABLE-PRESSURE
IMAGE DATA**

Table B1. AC-0 Raw Image Data (73° F)

Pressure	PSP	Io/I- psp		PSP-shellac	Io/I- psp shellac	P/Po
	x-132/y-256			x-450/y-256		
0.5	226.25	0.49379		144.2	0.562136	0.033784
5	200.09	0.558349		171.73	0.47202	0.337838
8	176.02	0.634701		165.6	0.489493	0.540541
11	149.6	0.746791		135.95	0.596249	0.743243
13.7	129.01	0.865979		98.78	0.820611	0.925676
14	129.34	0.86377		93.75	0.86464	0.945946
14.8	111.72	1		81.06	1	1
17.3	105.94	1.054559		71.77	1.129441	1.168919

Table B2. AC-1 Raw Image Data (100° F)

AC1 Raw Images- (100 deg F)						
Pressure	PSP	Io/I- PSP		PSP-shellac	Io/I- PSP shellac	P/Po
psi	x-132/y-256			x-374/y-256		
0.5	154.1	0.264114		80.61	0.392011	0.033784
5	80.4	0.506219		94.26	0.335243	0.337838
8	54.4	0.748162		36.04	0.876804	0.540541
11	40.36	1.008424		32.98	0.958156	0.743243
13.7	25.11	1.620868		21.38	1.478017	0.925676
14.8	40.7	1.18		31.6	1.25	1
17.4	21.03	1		19.22	1	1.175676
		1.93533			1.644121	

Table B3. AC-3 Raw Image Data (120° F)

AC3 Raw Images (120 deg F)						
PSP						
PSI	x-132/y-256	lo/l		PSP-shellac	lo/l	P/Po
0.5	110.48	0.260138		x-450/y-256	0.787906	0.033784
5	38.06	0.755123		33.57	0.676125	0.337838
8	30.67	0.937072		39.12	0.835967	0.540541
11	28.56	1.006303		31.64	0.967447	0.743243
13.7	28.59	1.005247		27.34	0.977819	0.925676
14	28.89	0.994808		27.05	1.004558	0.945946
14.8	28.74	1		26.33	1	1
17.3	28.43	1.010904		26.45	1.018091	1.168919
				25.98		

Table B4. AC-4 Raw Image Data (100° F)

AC4 Raw Images (100 deg F)					
PSP					
PSI	x-132/y-256	lo/l		PSP-shellac	lo/l
0.5	126.85	0.254474		61.2	0.527451
5	43.7	0.738673		35.9	0.899164
8	36.61	0.881726		36.29	0.889501
11	35.2	0.917045		35.4	0.911864
13.7	33.09	0.975521		34.75	0.928921
14	33.01	0.977885		33.41	0.966178
14.8	32.28	1		32.28	1
17.3	31.26	1.03263		31.1	1.037942

Table B5. AC-5 Raw Image Data (72° F)

AC5 Raw Images (72 deg F) [30 min expired from AC4 sample]					
PSP					
PSI	x-100/y-256	lo/l		PSP-shellac	lo/l
0.5	173.01	0.186579		61.2	0.527451
5	54.02	0.597556		35.9	0.899164
8	42.32	0.76276		36.29	0.889501
11	38.25	0.843922		35.4	0.911864
13.7	35.66	0.905216		34.75	0.928921
14	34.09	0.946905		33.41	0.966178
14.8	33.68	0.958432		32.28	1
17.3	32.54	0.99201		31.1	1.037942

Table B6. AC-6 Raw Image Data (73° F)

AC6 Raw Images (73deg F) [fresh sample]						
	PSP	lo/l	PSP-shellac		P/Po	
PSI	x-100/y-256		x-467/y-256	lo/l		
0.5	177.87	0.212234	43.31	1.165782	0.033784	
5	60.42	0.624793	51.08	0.988449	0.337838	
8	49.02	0.770094	53.89	0.936909	0.540541	
11	42.84	0.881186	55.9	0.90322	0.743243	
13.7	38.91	0.970188	52.92	0.954082	0.925676	
14	38.91	0.970188	52.39	0.963734	0.945946	
14.8	37.75	1	50.49	1	1	
17.3	35.8	1.054469	47.68	1.058935	1.168919	
19	34.58	1.091671	45.71	1.104572	1.283784	
20	34.25	1.10219	43.92	1.14959	1.351351	
25	31.9	1.183386	40.72	1.239931	1.689189	

Table B7. AC-7 Raw Image Data (125° F)

AC7 Raw Image Data					
PSI	x-100/y-256	lo/l	x-550/y-256	lo/l	P/Po
0.5	94.32	0.298982	127.46	0.27844	0.033784
5	36.57	0.771124	46.33	0.766026	0.337838
8	30.69	0.918866	50.15	0.707677	0.540541
11	29.14	0.967742	46.05	0.770684	0.743243
13.7	26.8	1.052239	36.91	0.961528	0.925676
14	28.13	1.002488	36.28	0.978225	0.945946
14.8	28.2	1	35.49	1	1
17.3	27.99	1.007503	33.57	1.057194	1.168919
14.8	21.84		40.92		1

Table B8. AC-8 Raw Image Data (125° F)

AC8 Ratio Images (125 deg F)						
PSI	lo/l-PSP	lo/l-PSP	lo/l-PSPshellac	{Co=25 y-mean}		P/Po
0.5	2.95	0.093031	9.03	0.261109		0.033784
5	11.87	0.37433	19.7	0.569639		0.337838
8	19.05	0.600757	28.65	0.828435		0.540541
11	27.19	0.857458	33.54	0.969832		0.743243
13.7	34.87	1.099653	41.95	1.213013		0.925676
14	31.01	0.977925	34.5896	1.000182		0.945946
14.8	31.71	1	34.5833	1		1
17.3	34.96	1.102491	42.02	1.215037		1.168919
20	41.41	1.305897	56.95	1.646749		1.351351
25	47.16	1.487228	58.49	1.691279		1.689189

Table B9. Raw Image Data (100° F)

AC9 Ratioed Images (100 deg F) {Co=25 y-mean value}						
psi	x-100/y-256		x-550/y-256		P/Po	
	lo/l	lo/l	lo/l	lo/l		
0.5	3.49	0.127372	14.01	0.422624	0.033784	
5	10.96	0.4	23.89	0.720664	0.337838	
8	16.15	0.589416	21.7	0.6546	0.540541	
11	18.72	0.683212	21.16	0.638311	0.743243	
13.7	23.75	0.866788	26.27	0.792459	0.925676	
14	25.43	0.928102	28.37	0.855807	0.945946	
14.8	27.4	1	33.15	1	1	
17.3	33.19	1.211314	38.7	1.167421	1.168919	
20	39.6	1.445255	46.68	1.408145	1.351351	
25	47.37	1.728832	51.54	1.554751	1.689189	

Table B10. Raw Image Data (85° F)

AC10 Ratioed Images (85 deg F) {Co=25 y-mean values}						
psi	x-100/y-256		x-550/y-256		P/Po	
	lo/l	lo/l	lo/l	lo/l		
0.5	4.24	0.154745	25.92	0.856293	0.033784	
5	12.31	0.44927	20.48	0.676577	0.337838	
8	16.76	0.611679	20.83	0.68814	0.540541	
11	21.61	0.788686	23.83	0.787248	0.743243	
13.7	24.65	0.899635	26.45	0.873802	0.925676	
14.8	27.4	1	30.27	1	1	
17.3	29.77	1.086496	34.68	1.145689	1.168919	

**B.2 CONSTANT-PRESSURE, VARIABLE-TEMPERATURE RAW
IMAGE DATA**

Table B11. BC-2 Raw Image Data (0.5 psi)

BC2- Low Pressure (0.5 Psi) Variable Temperature Constant Pressure variable temperature (Co=10)		
llo/l	lo/l Raw Data	lo/l
71.1	10	1
100	15.13	0.660939
110	17.03	0.587199
117.5	18.72	0.534188
125.5	19.23	0.520021
133.7	20.31	0.492368
145.1	21.94	0.455789

Table B12. BC-1 Raw Image Data (14.8 psi)

BC1- Ambient Pressure (14.8) Variable Temperature Constant Pressure variable temperature (Co=10)			
Temp (° F)	lo/l Raw Data	lo/l	T/To
81.4	19.69	1.0	1.132128
91	33.44	0.58882	1.265647
101.5	41.27	0.47710	1.411683
120.1	61.72	0.31902	bad data
126.3	57.52	0.34232	1.756606
136.5	56.67	0.34745	1.89847
145	59.95	0.32844	2.01669

Table B13. BC-4 Raw Image Data (25.0 psi)

BC4-Hi Pressure (25.0 Psi) Variable Temperature (Co=			
Temp (° F)	lo/l	lo/l	
71.7	16.63	1	
84.8	22	0.454545	
100.6	33.46	0.298864	bad
110.5	23.12	0.432526	
120.8	27.77	0.360101	
125.8	34.02	0.293945	bad
131.7	22	0.454545	bad
145.2	30.5	0.327869	
153.3	26.88	0.372024	

B.3 TIME DETERIORATION RAW IMAGE DATA

Table B14. BC-3 Time Deterioration (80° F)

time (min)	lo/l	lo/l
5	10.51	1
10	9.95	0.995
25	8.69	0.869
35	9.75	0.975
40	9.48	0.948
50	8.99	0.899
65	1.09	0.109
bad Points:		
time	lo/l	
15	20.82 noisy data	
20	16.33 noisy data	
30	16.48 noisy data	

**APPENDIX C. CORRECTED CONSTANT-TEMPERATURE,
VARIABLE-PRESSURE DATA CALCULATIONS**

**C.1 CORRECTED CONSTANT-TEMPERATURE, VARIABLE-
PRESSURE DATA**

Table C1. AC-5 72° F Constant-Temperature, Variable-Pressure

AC5 Ratio Images (72 deg {Co=25 y-mean})					
Psi	lo/l-PSP	lo/l-PSP	lo/l-PSPshellac		P/Po
0.5	2.71	0.10439	40.72	1.54009	0.03378
5	13.38	0.51540	32.31	1.22201	0.33783
8	19.15	0.73767	26.23	0.99205	0.54054
11	23.75	0.91486	28.59	1.08131	0.74324
13.7	27.66	1.06548	28.14	1.06429	0.92567
14	26.87	1.03505	29.8	1.12708	0.94594
14.8	25.96	1.000	26.44	1	1
17.3	30.12	1.16024	32.03	1.21142	1.16891

Table C2. AC-6 73° F Constant-Temperature, Variable-Pressure

AC6 Ratio Images (73 deg F) {Co=25 y-mean}					
(psi)	lo/l-PSP	lo/l-PSP	lo/l-PSPshellac		P/Po
0.5	5.07	0.188336	38.96	1.37425	0.033784
5	13.96	0.518574	29.59	1.043739	0.337838
8	17.17	0.637816	27.3	0.962963	0.540541
11	22.67	0.842125	25.88	0.912875	0.743243
13.7	27.08	1.005944	27.44	0.967901	0.925676
14	28.14	1.045319	28.53	1.006349	0.945946
14.8	26.92	1	28.35	1	1
17.3	33.68	1.251114	31.18	1.099824	1.168919
19	36.3	1.34844	35.22	1.242328	1.283784
20	35.33	1.312407	38.53	1.359083	1.351351
25	45.76	1.699851	45.72	1.612698	1.689189
	30.82		43.91		

Table C3. AC-8 125° F Constant-Temperature, Variable-Pressure

AC8 Ratio Images (125 deg F) {Co=25 y-mean}					
(psi)	lo/I-PSF	lo/I-PSP	lo/I-PSPshellac		P/Po
0.5	2.95	0.093031	9.03	0.261109	0.033784
5	11.87	0.37433	19.7	0.569639	0.337838
8	19.05	0.600757	28.65	0.828435	0.540541
11	27.19	0.857458	33.54	0.969832	0.743243
13.7	34.87	1.099653	41.95	1.213013	0.925676
14	31.01	0.977925	34.589	1.000182	0.945946
14.8	31.71	1	34.583	1	1
17.3	34.96	1.102491	42.02	1.215037	1.168919
20	41.41	1.305897	56.95	1.646749	1.351351
25	47.16	1.487228	58.49	1.691279	1.689189
	25.04		28.19		

Table C4. AC-9 100° F Constant-Temperature, Variable-Pressure

AC9 Ratioed Images (100 deg F) {Co=25 y-mean value}					
psi	lo/I-ppp	lo/I-ppp	lo/I-ppp shellac		P/Po
0.5	3.49	0.127372	14.01	0.422624	0.033784
5	10.96	0.4	23.89	0.720664	0.337838
8	16.15	0.589416	21.7	0.6546	0.540541
11	18.72	0.683212	21.16	0.638311	0.743243
13.7	23.75	0.866788	26.27	0.792459	0.925676
14	25.43	0.928102	28.37	0.855807	0.945946
14.8	27.4	1.00	33.15	1.00	1
17.3	33.19	1.211314	38.7	1.167421	1.168919
20	39.6	1.445255	46.68	1.408145	1.351351
25	47.37	1.728832	51.54	1.554751	1.689189

Table C5. AC-10 85° F Constant-Temperature, Variable-Pressure

AC10 Ratioed Images (85 deg F) {Co=25 y-mean values}					
psi	lo/l-ppp	lo/l-ppp	lo/l-ppp shellac		P/Po
0.5	4.24	0.154745	25.92	0.856293	0.033784
5	12.31	0.44927	20.48	0.676577	0.337838
8	16.76	0.611679	20.83	0.68814	0.540541
11	21.61	0.788686	23.83	0.787248	0.743243
13.7	24.65	0.899635	26.45	0.873802	0.925676
14.8	27.4	1	30.27	1.0	1
17.3	29.77	1.086496	34.68	1.145689	1.168919

C.2 CORRECTED HIGH ERROR POINT REJECTION DATA SHEETS

Table C6. AC-5 72° F Constant-Temperature, Variable-Pressure

#Hi Pt	Sum		NuPsPlo/l	#Hi Pt	Sum	NuAvgPs	Nushello/l
1	255	2.182197	0.087289	26	5147	31.6951	1.267829
5	1061	11.28274	0.451316	25	3808	25.70152	1.028081
7	1065	17.17765	0.687115	12	2399	21.76696	0.870696
14	2069	20.01559	0.800635	23	3835	21.62195	0.864895
15	2649	22.84513	0.913818	19	3539	21.60883	0.86437
8	1295	24.57692	0.98309	18	3454	23.47115	0.938865
2	510	24.99966	1	3	765	24.9995	1
6	1295	27.76423	1.110584	9	1869	28.66674	1.146693
avg noise		1274.875		avg noise		3102	

Table C7. AC-6 73° F Constant-Temperature, Variable-Pressure

#Hi value	sum#Hi value	NuAvgPSP	NuPsPlo/l	#Hi value	sumHi val	NuAvgsPsP	Nushello/l	NuPsPlo/l	Nushello/l
7	1261	2.473581	0.09707	21	3872	32.29223	1.243962		1.243962
9	2162	9.627319	0.377801	12	2737	24.48953	0.943386	0.09707	0.943386
40	5896	5.303941	0.20814	39	7171	13.42205	0.517044	0.377801	0.517044
7	1365	20.11426	0.789336	12	2823	20.50004	0.789703		0.789703 Hi error del
9	1900	23.556	0.924398	11	2545	22.64692	0.872405	0.789336	0.872405
10	2177	24.09821	0.945676	13	2907	23.0877	0.889385	0.924398	0.889385
3	765	25.48252	1	5	1275	25.95918	1	0.945676	1
9	2189	29.66749	1.164229	9	2029	27.46004	1.057816	1	1.057816
15	2842	31.34849	1.230196	14	3151	29.50404	1.136555	1.164229	1.136555
10	1928	31.97243	1.254681	15	3542	32.14196	1.238173	1.230196	1.238173
18	3727	39.46213	1.548596	18	4008	38.81102	1.495079	1.254681	1.495079
14	2670	26.00598		26	5042	35.29998		1.548596	
avg noise		2406.833		avg noise		2874.417			

Table C8. AC-8 125° F Constant-Temperature, Variable-Pressure

#Hi value	sum#Hi value	NuAvgPSP	NuPsPlo/l	#Hi value	sumHi val	NuAvgsPsP	Nushello/l	NuPsPlo/l	Nushello/l
3	520	1.876155	0.075084	12	2290	4.358394	0.171057	0.075084	0.171057
7	1667	8.514258	0.340744	15	3278	13.2722	0.520905	0.340744	0.520905
11	2532	14.0875	0.563787	19	4727	19.55728	0.76758	0.563787	0.76758
16	3224	21.16633	0.847084	18	4350	25.41358	0.997427	0.847084	0.997427
21	4085	27.54963	1.102546	24	5565	31.93198	1.25326		Hi error del
13	3315	24.76135	0.990958	21	5173	24.88083	0.976518	0.990958	0.976518
14	3570	24.98729	1	19	4845	25.47913	1	1	1
20	4425	26.84279	1.074258	21	4800	33.46633	1.31348	1.074258	1.31348
27	5312	32.13139	1.28591	53	10459	39.48369	1.549648	1.28591	1.549648
41	6901	35.81881	1.433481	56	9856	42.93312	1.685031	1.433481	1.685031
13	3315	18.62481	0.745371	21	5355	17.79041	0.698235	0.745371	0.698235
avg noise		3533.273		avg noise		5518			

Table C9. AC-9 100° F Constant-Temperature, Variable-Pressure

#Hi value	sum#Hi value	NuAvgPSP	NuPsPlo/l	#Hi value	sumHi val	NuAvgsPsP	Nushello/l	NuPsPlo/l
4	1020	1.372021	0.05284	11	2805	8.345705	0.334006	0.05284
4	1020	8.904926	0.342952	9	2295	19.46449	0.778994	0.342952
3	760	14.65515	0.564407	11	2805	16.21645	0.649004	0.564407
4	1020	16.73027	0.644326	12	2905	15.48317	0.619657	0.644326
33	5358	13.49383	0.519682	40	7643	11.2536	0.450384	
6	1530	22.51791	0.867222	11	2805	23.04323	0.92222	0.867222
3	765	25.96555	1	17	4335	24.98669	1	1
10	1942	29.75695	1.146017	16	3925	31.56004	1.263074	1.146017
9	1985	36.13489	1.391648	27	6315	35.49717	1.420643	1.391648
21	4853	38.94592	1.499907	30	6045	41.5204	1.661701	1.499907
avg noise		2025.3		avg noise		4187.8		

Table C10. AC-10 85° F Constant-Temperature, Variable-Pressure

#Hi value	sum#Hi	NuAvgPSP	Nu PSP lo/l	#Hi	sumHi	NuAvgsPsP	Nu shellac lo/l
3	765	2.65958	0.109185	11	2520	21.14462	0.814299
4	1020	10.24473	0.420583	11	2805	14.96778	0.576423
3	765	15.25849	0.626416	10	2550	15.83704	0.609899
3	765	20.13905	0.826781	11	2805	18.39652	0.708467
2	510	23.73393	0.974363	11	2675	21.35588	0.822434
6	1530	24.3584	1	9	2295	25.96666	1
5	1195	27.44712	1.126803	12	3060	29.01867	1.117536
3	765	26.09637	1.07135	18	4111	33.61056	1.294374

C.3 CORRECTED HIGH ERROR POINT REJECTION FIGURES

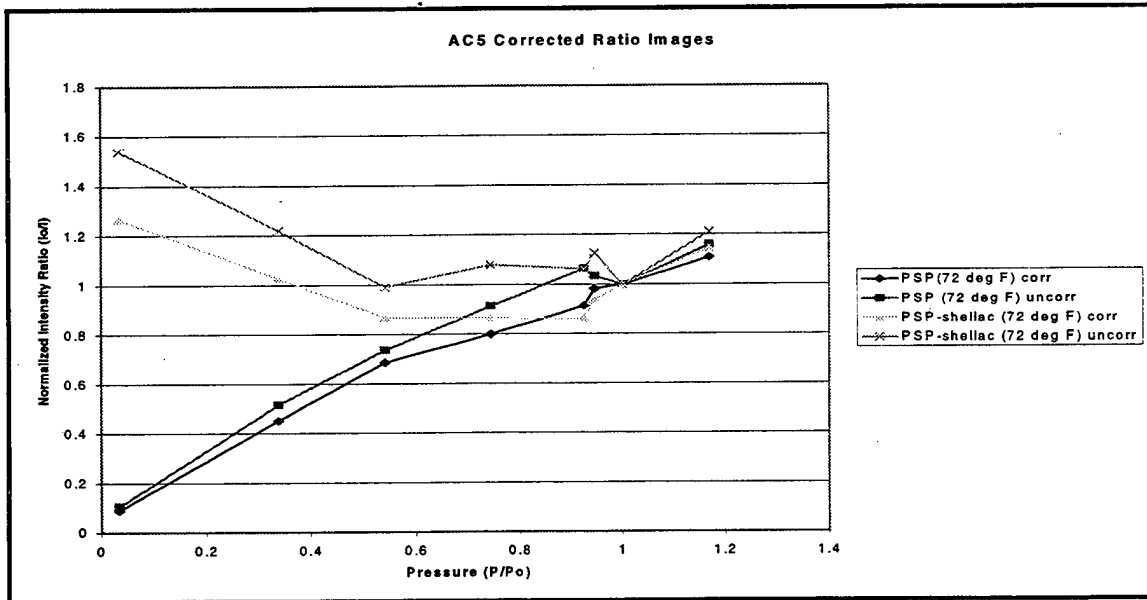

Figure C1. AC-5 Corrected Intensity Ratio

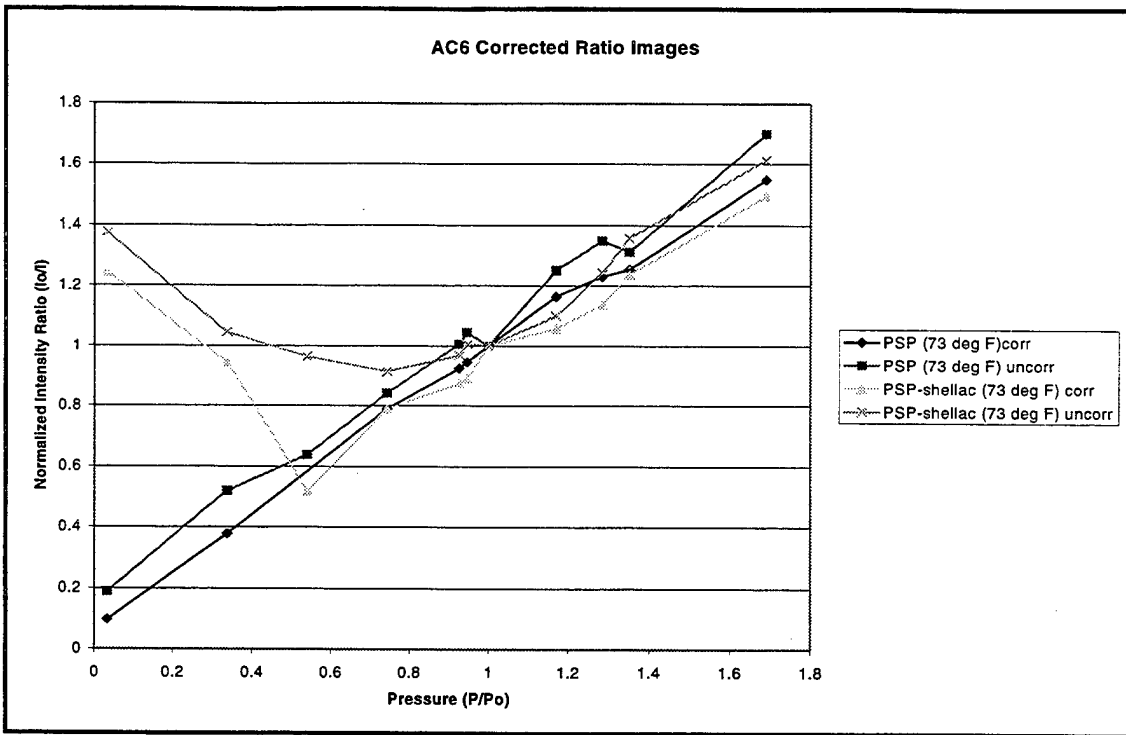

Figure C2. AC-6 Corrected Intensity Ratio

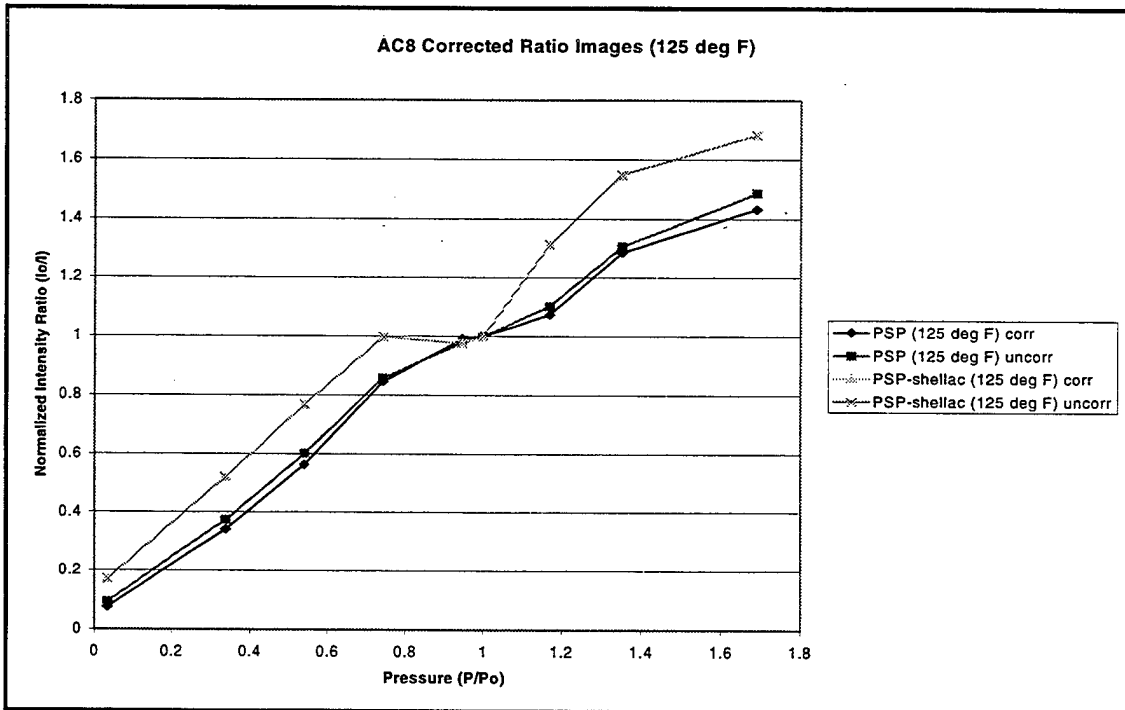

Figure C3. AC-8 Corrected Intensity Ratio

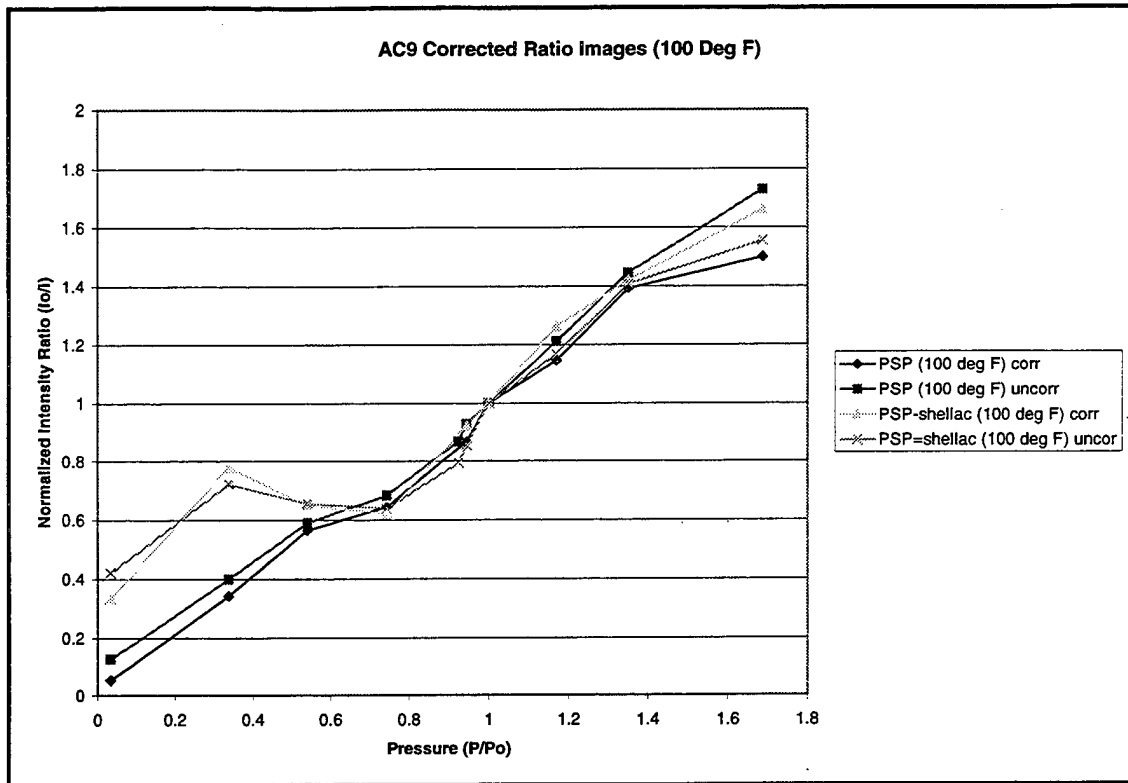

Figure C4. AC-8 Corrected Intensity Ratio

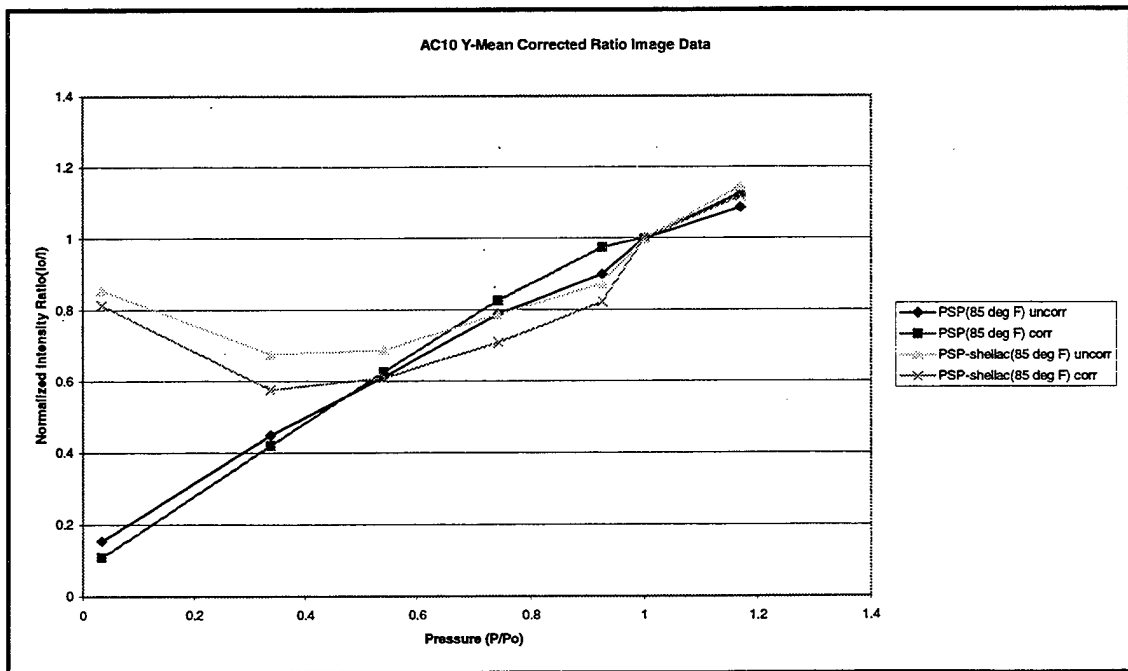

Figure C5. AC-8 Corrected Intensity Ratio

APPENDIX D. NASA-AMES CALIBRATION DATA

Table D1. PSP Constant-Temperature, Variable-Pressure (68° F)

TITLE: PSPcal version 0.01+									
HEADER: Start Time: 7/28/98 2:17:39 PM									
SAMPLE_NPOINTS: 10000									
SAMPLE_RATE: 1000.000000									
CAL_NPOINTS: 12									
CAL_QUANTITIES: 9									
DATA:	Pressure	stable_win	Temperatu	std(T)	l_paint	std(l_paint)	l_lamp	std(l_lamp)	time(sec)
CAL_DAT/	1.47E+01	4.00E-03	6.80E+01	9.49E-03	5.41E-01	4.28E-03	7.02E-01	2.03E-02	3.66E+02
CAL_DAT/	1.85E+00	4.00E-03	6.79E+01	2.35E-02	1.87E+00	7.34E-03	7.05E-01	1.97E-02	5.42E+02
CAL_DAT/	1.17E+01	4.00E-03	6.78E+01	2.45E-02	6.33E-01	4.21E-03	7.07E-01	1.94E-02	6.10E+02
CAL_DAT/	5.13E+00	4.00E-03	6.82E+01	4.27E-02	1.04E+00	4.87E-03	7.09E-01	1.94E-02	6.94E+02
CAL_DAT/	6.78E+00	4.00E-03	6.80E+01	1.04E-02	8.85E-01	4.40E-03	7.08E-01	1.96E-02	9.72E+02
CAL_DAT/	1.34E+01	4.00E-03	6.80E+01	1.07E-02	5.77E-01	3.63E-03	7.12E-01	1.94E-02	1.15E+03
CAL_DAT/	2.00E-01	4.00E-03	6.79E+01	1.88E-02	3.91E+00	1.30E-02	7.12E-01	1.94E-02	1.32E+03
CAL_DAT/	1.01E+01	4.00E-03	6.79E+01	6.26E-02	6.96E-01	3.72E-03	7.13E-01	1.92E-02	1.38E+03
CAL_DAT/	1.50E+01	4.00E-03	6.79E+01	6.50E-02	5.41E-01	3.41E-03	7.13E-01	1.92E-02	1.41E+03
CAL_DAT/	3.49E+00	4.00E-03	6.79E+01	6.87E-02	1.31E+00	5.36E-03	7.13E-01	1.94E-02	1.57E+03
CAL_DAT/	8.42E+00	4.00E-03	6.80E+01	1.17E-02	7.66E-01	3.76E-03	7.13E-01	1.90E-02	1.69E+03
CAL_DAT/	1.47E+01	4.00E-03	6.80E+01	2.87E-02	5.38E-01	3.53E-03	7.15E-01	1.98E-02	1.84E+03
CAL_TYPE: Constant Temperature									
CALIBRATION: Pressure (P/Po), Normalized Intensity Ratio (Io/I)									
CAL_POIN	1.00E+00	9.76E-01							
CAL_POIN	1.25E-01	2.83E-01							
CAL_POIN	7.96E-01	8.41E-01							
CAL_POIN	3.49E-01	5.12E-01							
CAL_POIN	4.61E-01	6.02E-01							
CAL_POIN	9.08E-01	9.27E-01							
CAL_POIN	1.36E-02	1.37E-01							
CAL_POIN	6.84E-01	7.71E-01							
CAL_POIN	1.02E+00	9.92E-01							
CAL_POIN	2.37E-01	4.09E-01							
CAL_POIN	5.72E-01	7.00E-01							
CAL_POIN	1.00E+00	1.00E+00							
LIN_FITYX	1.96E-01	8.10E-01	9.74E-04						
QUAD_FIT	1.37E-01	1.16E+00	-3.15E-01	1.24E-04					
LIN_FITXY	-2.31E-01	1.22E+00	1.47E-03						
QUAD_FIT	-7.81E-02	5.66E-01	5.38E-01	1.20E-04					

Table D2. PSP Constant-Temperature, Variable-Pressure (68° F) Repeated

```

TITLE: PSPcal version 0.01+
HEADER: Start Time: 7/29/98 9:41:11 AM
SAMPLE_NPOINTS: 10000
SAMPLE_RATE: 1000.000000
CAL_NPOINTS: 12
CAL_NQUANTITIES: 9
DATA:  Pressure  stable_win  Temperatu std(T)    l_paint    std(l_paint) l_lamp    std(l_lamp) time(sec)
CAL_DAT/ 1.47E+01  4.00E-03  6.80E+01  2.47E-02  5.37E-01  4.58E-03  7.24E-01  2.01E-02  3.77E+02
CAL_DAT/ 1.50E+01  4.00E-03  6.80E+01  1.30E-02  5.30E-01  4.18E-03  7.24E-01  1.96E-02  5.15E+02
CAL_DAT/ 1.84E+00  4.00E-03  6.80E+01  5.36E-02  1.72E+00  6.71E-03  7.23E-01  1.97E-02  6.86E+02
CAL_DAT/ 6.78E+00  4.00E-03  6.79E+01  6.28E-02  8.49E-01  4.61E-03  7.24E-01  1.95E-02  7.32E+02
CAL_DAT/ 1.17E+01  4.00E-03  6.79E+01  3.05E-02  6.13E-01  4.20E-03  7.23E-01  1.94E-02  7.83E+02
CAL_DAT/ 8.42E+00  4.00E-03  6.80E+01  2.78E-02  7.38E-01  4.36E-03  7.23E-01  1.95E-02  8.61E+02
CAL_DAT/ 2.00E-01  4.00E-03  6.79E+01  6.64E-02  3.50E+00  1.17E-02  7.23E-01  1.96E-02  1.02E+03
CAL_DAT/ 1.01E+01  4.00E-03  6.79E+01  3.50E-02  6.67E-01  4.16E-03  7.23E-01  1.94E-02  1.08E+03
CAL_DAT/ 1.34E+01  4.00E-03  6.80E+01  1.28E-02  5.59E-01  3.89E-03  7.23E-01  1.93E-02  1.22E+03
CAL_DAT/ 3.49E+00  4.00E-03  6.79E+01  5.46E-02  1.21E+00  5.42E-03  7.24E-01  1.95E-02  1.40E+03
CAL_DAT/ 5.13E+00  4.00E-03  6.80E+01  1.08E-02  9.73E-01  4.74E-03  7.25E-01  1.94E-02  1.56E+03
CAL_DAT/ 1.47E+01  4.00E-03  6.79E+01  9.91E-02  5.28E-01  4.10E-03  7.25E-01  1.98E-02  1.63E+03
CAL_TYPE: Constant Temperature
CALIBRATION: Pressure (P/Po), Normalized Intensity Ratio (Io/I)
CAL_POIN 1.00E+00  9.82E-01
CAL_POIN 1.02E+00  9.96E-01
CAL_POIN 1.25E-01  3.06E-01
CAL_POIN 4.60E-01  6.21E-01
CAL_POIN 7.95E-01  8.59E-01
CAL_POIN 5.72E-01  7.13E-01
CAL_POIN 1.36E-02  1.50E-01
CAL_POIN 6.83E-01  7.89E-01
CAL_POIN 9.07E-01  9.42E-01
CAL_POIN 2.37E-01  4.34E-01
CAL_POIN 3.48E-01  5.42E-01
CAL_POIN 1.00E+00  1.00E+00
LIN_FITYX 2.21E-01  7.93E-01  1.27E-03
QUAD_FIT 1.54E-01  1.19E+00 -3.63E-01  1.40E-04
LIN_FITXY -2.64E-01  1.24E+00  1.98E-03
QUAD_FIT -6.90E-02  4.33E-01  6.54E-01  8.51E-05
    
```

Table D3. PSP-Shellac Constant-Temperature, Variable-Pressure (38° F)

```

TITLE: PSPcal version 0.01+
HEADER: Start Time: 7/31/98 2:25:52 PM
SAMPLE_NPOINTS: 10000
SAMPLE_RATE: 1000.000000
CAL_NPOINTS: 12
CAL_NQUANTITIES: 9
DATA:  Pressure  stable_win  Temperatu std(T)    l_paint  std(l_paint) l_lamp  std(l_lamp) time(sec)
CAL_DAT/ 1.47E+01  4.00E-03  3.80E+01  2.65E-02  2.50E+00  8.46E-03  6.73E-01  1.61E-02  3.56E+02
CAL_DAT/ 1.84E+00  4.00E-03  3.80E+01  1.70E-02  2.90E+00  1.02E-02  6.74E-01  1.57E-02  7.01E+02
CAL_DAT/ 1.50E+01  4.00E-03  3.78E+01  1.26E-02  2.88E+00  9.77E-03  6.74E-01  1.57E-02  8.59E+02
CAL_DAT/ 6.78E+00  4.00E-03  3.80E+01  9.92E-03  2.83E+00  8.91E-03  6.75E-01  1.58E-02  1.10E+03
CAL_DAT/ 1.17E+01  4.00E-03  3.79E+01  1.75E-02  2.83E+00  8.94E-03  6.76E-01  1.59E-02  1.22E+03
CAL_DAT/ 8.42E+00  4.00E-03  3.81E+01  2.53E-02  2.76E+00  8.46E-03  6.77E-01  1.61E-02  1.35E+03
CAL_DAT/ 1.01E+01  4.00E-03  3.80E+01  1.56E-02  2.77E+00  8.52E-03  6.78E-01  1.62E-02  1.46E+03
CAL_DAT/ 3.49E+00  4.00E-03  3.80E+01  1.35E-02  3.12E+00  9.79E-03  6.80E-01  1.63E-02  1.83E+03
CAL_DAT/ 1.34E+01  4.00E-03  3.80E+01  1.24E-02  2.90E+00  9.77E-03  6.78E-01  1.60E-02  2.11E+03
CAL_DAT/ 2.00E-01  4.00E-03  3.79E+01  9.19E-03  3.22E+00  1.20E-02  6.82E-01  1.64E-02  2.38E+03
CAL_DAT/ 5.13E+00  4.00E-03  3.80E+01  1.17E-02  3.37E+00  9.71E-03  6.82E-01  1.61E-02  2.64E+03
CAL_DAT/ 1.47E+01  4.00E-03  3.80E+01  9.91E-03  2.13E+00  7.02E-03  6.84E-01  1.66E-02  3.92E+03
CAL_TYPE: Constant Temperature
CALIBRATION: Pressure (P/Po), Normalized Intensity Ratio (Io/I)
CAL_POIN 1.00E+00  8.40E-01
CAL_POIN 1.25E-01  7.25E-01
CAL_POIN 1.02E+00  7.30E-01
CAL_POIN 4.60E-01  7.45E-01
CAL_POIN 7.94E-01  7.45E-01
CAL_POIN 5.71E-01  7.64E-01
CAL_POIN 6.83E-01  7.63E-01
CAL_POIN 2.37E-01  6.80E-01
CAL_POIN 9.06E-01  7.29E-01
CAL_POIN 1.36E-02  6.60E-01
CAL_POIN 3.48E-01  6.32E-01
CAL_POIN 1.00E+00  1.00E+00
LIN_FITX 6.50E-01  1.70E-01  4.86E-03
QUAD_FIT 6.79E-01  -7.84E-03  1.61E-01  4.64E-03
LIN_FITXY -1.23E+00  2.43E+00  6.93E-02
QUAD_FIT -7.03E+00  1.69E+01  -8.85E+00  5.88E-02
    
```

Table D4. PSP-Shellac Constant-Temperature, Variable-Pressure (68° F)

```

TITLE: PSPcal version 0.01+
HEADER: Start Time: 7/29/98 10:27:25 AM
SAMPLE_NPOINTS: 10000
SAMPLE_RATE: 1000.000000
CAL_NPOINTS: 12
CAL_NQUANTITIES: 9
DATA:  Pressure  stable_wini  Temperatu  std(T)    l_paint   std(l_paint)  l_lamp   std(l_lamp)  time(sec)
CAL_DAT/ 1.47E+01  4.00E-03  6.79E+01  3.78E-02  1.31E+00  5.76E-03  6.94E-01  1.93E-02  3.79E+02
CAL_DAT/ 6.78E+00  4.00E-03  6.82E+01  2.15E-02  1.43E+00  7.82E-03  6.94E-01  1.82E-02  4.95E+02
CAL_DAT/ 3.49E+00  4.00E-03  6.80E+01  1.23E-02  2.01E+00  1.50E-02  6.93E-01  1.84E-02  6.54E+02
CAL_DAT/ 2.00E-01  4.00E-03  6.80E+01  1.19E-02  4.49E+00  1.44E-02  6.92E-01  1.84E-02  1.05E+03
CAL_DAT/ 1.34E+01  4.00E-03  6.80E+01  1.24E-02  1.44E+00  7.49E-03  6.93E-01  1.81E-02  1.35E+03
CAL_DAT/ 8.42E+00  4.00E-03  6.81E+01  2.33E-02  1.42E+00  5.69E-03  6.93E-01  1.81E-02  1.46E+03
CAL_DAT/ 5.13E+00  4.00E-03  6.80E+01  1.25E-02  1.53E+00  8.33E-03  6.93E-01  1.82E-02  1.55E+03
CAL_DAT/ 1.01E+01  4.00E-03  6.79E+01  1.60E-02  1.58E+00  6.78E-03  6.93E-01  1.80E-02  1.68E+03
CAL_DAT/ 1.50E+01  4.00E-03  6.80E+01  1.22E-02  1.16E+00  5.81E-03  6.93E-01  1.81E-02  1.91E+03
CAL_DAT/ 1.17E+01  4.00E-03  6.80E+01  9.93E-03  1.12E+00  4.90E-03  6.93E-01  1.80E-02  2.02E+03
CAL_DAT/ 1.85E+00  4.00E-03  6.80E+01  1.27E-02  3.33E+00  1.32E-02  6.92E-01  1.83E-02  2.65E+03
CAL_DAT/ 1.47E+01  4.00E-03  6.80E+01  1.27E-02  1.17E+00  5.91E-03  6.94E-01  1.91E-02  2.98E+03
CAL_TYPE: Constant Temperature
CALIBRATION: Pressure (P/Po), Normalized Intensity Ratio (I/I)
CAL_POIN 1.00E+00  8.90E-01
CAL_POIN 4.60E-01  8.17E-01
CAL_POIN 2.37E-01  5.79E-01
CAL_POIN 1.36E-02  2.59E-01
CAL_POIN 9.07E-01  8.08E-01
CAL_POIN 5.72E-01  8.18E-01
CAL_POIN 3.48E-01  7.59E-01
CAL_POIN 6.83E-01  7.39E-01
CAL_POIN 1.02E+00  1.01E+00
CAL_POIN 7.95E-01  1.04E+00
CAL_POIN 1.25E-01  3.49E-01
CAL_POIN 1.00E+00  1.00E+00
LIN_FITYX 3.92E-01  6.09E-01  1.24E-02
QUAD_FIT 2.42E-01  1.50E+00 -8.08E-01  6.85E-03
LIN_FITXY -3.70E-01  1.28E+00  2.61E-02
QUAD_FIT -1.88E-01  6.17E-01  5.07E-01  2.54E-02
    
```

Table D5. PSP-Shellac Constant-Temperature, Variable-Pressure (53° F)

```

TITLE: PSPcal version 0.01+
HEADER: Start Time: 8/3/98 9:50:45 AM
SAMPLE_NPOINTS: 10000
SAMPLE_RATE: 1000.000000
CAL_NPOINTS: 12
CAL_NQUANTITIES: 9
DATA:  Pressure  stable_wini  Temperatu  std(T)  I_paint  std(I_paint)  I_lamp  std(I_lamp)  time(sec)
CAL_DAT/ 1.47E+01  4.00E-03  5.30E+01  1.18E-02  1.67E+00  7.96E-03  6.70E-01  1.60E-02  4.20E+02
CAL_DAT/ 8.42E+00  4.00E-03  5.30E+01  1.15E-02  1.58E+00  6.51E-03  6.72E-01  1.57E-02  8.11E+02
CAL_DAT/ 1.01E+01  4.00E-03  5.30E+01  1.20E-02  1.55E+00  6.17E-03  6.72E-01  1.55E-02  9.53E+02
CAL_DAT/ 6.78E+00  4.00E-03  5.30E+01  1.49E-02  1.55E+00  6.06E-03  6.71E-01  1.54E-02  1.05E+03
CAL_DAT/ 1.17E+01  4.00E-03  5.30E+01  1.05E-02  1.48E+00  5.99E-03  6.75E-01  1.56E-02  1.25E+03
CAL_DAT/ 2.00E-01  4.00E-03  5.30E+01  1.23E-02  3.03E+00  1.20E-02  6.76E-01  1.59E-02  2.00E+03
CAL_DAT/ 1.50E+01  4.00E-03  5.30E+01  1.10E-02  1.49E+00  6.64E-03  6.76E-01  1.57E-02  2.43E+03
CAL_DAT/ 1.34E+01  4.00E-03  5.30E+01  9.59E-03  1.35E+00  5.64E-03  6.77E-01  1.56E-02  2.64E+03
CAL_DAT/ 3.49E+00  4.00E-03  5.30E+01  1.28E-02  1.53E+00  6.07E-03  6.78E-01  1.59E-02  2.97E+03
CAL_DAT/ 1.84E+00  4.00E-03  5.30E+01  1.27E-02  1.65E+00  6.88E-03  6.77E-01  1.59E-02  3.09E+03
CAL_DAT/ 5.13E+00  4.00E-03  5.30E+01  1.13E-02  1.74E+00  6.09E-03  6.78E-01  1.57E-02  3.33E+03
CAL_DAT/ 1.47E+01  4.00E-03  5.30E+01  1.13E-02  1.33E+00  5.80E-03  6.79E-01  1.60E-02  3.74E+03
CAL_TYPE: Constant Temperature
CALIBRATION: Pressure (P/Po), Normalized Intensity Ratio (Io/I)
CAL_POIN 1.00E+00  7.85E-01
CAL_POIN 5.73E-01  8.37E-01
CAL_POIN 6.85E-01  8.52E-01
CAL_POIN 4.61E-01  8.52E-01
CAL_POIN 7.96E-01  8.92E-01
CAL_POIN 1.36E-02  4.39E-01
CAL_POIN 1.02E+00  8.91E-01
CAL_POIN 9.08E-01  9.86E-01
CAL_POIN 2.37E-01  8.67E-01
CAL_POIN 1.25E-01  8.07E-01
CAL_POIN 3.49E-01  7.63E-01
CAL_POIN 1.00E+00  1.00E+00
LIN_FITX 6.72E-01  2.66E-01  1.02E-02
QUAD_FIT 5.69E-01  8.77E-01  -5.51E-01  7.60E-03
LIN_FITXY -8.10E-01  1.69E+00  6.50E-02
QUAD_FIT 1.44E-01  -1.15E+00  1.99E+00  6.20E-02
    
```

Table D6. PSP Constant-Temperature, Variable-Pressure (38° F) Repeated

```

TITLE: PSPcal version 0.01+
HEADER: Start Time: 7/31/98 9:47:50 AM
SAMPLE_NPOINTS: 10000
SAMPLE_RATE: 1000.000000
CAL_NPOINTS: 12
CAL_NQUANTITIES: 9
DATA:  Pressure  stable_win  Temperatu std(T)  I_paint  std(I_paint) I_lamp  std(I_lamp) time(sec)
CAL_DAT/ 1.48E+01  4.00E-03  3.79E+01  4.40E-02  9.22E-01  5.13E-03  7.02E-01  1.92E-02  1.98E+02
CAL_DAT/ 1.50E+01  4.00E-03  3.80E+01  2.22E-02  9.16E-01  5.32E-03  7.01E-01  1.91E-02  3.09E+02
CAL_DAT/ 6.78E+00  4.00E-03  3.80E+01  1.26E-02  1.44E+00  6.47E-03  7.01E-01  1.91E-02  5.12E+02
CAL_DAT/ 1.01E+01  4.00E-03  3.80E+01  1.37E-02  1.16E+00  5.85E-03  7.04E-01  1.88E-02  6.12E+02
CAL_DAT/ 1.84E+00  4.00E-03  3.81E+01  6.46E-02  2.64E+00  9.55E-03  7.03E-01  1.92E-02  7.12E+02
CAL_DAT/ 8.42E+00  4.00E-03  3.81E+01  4.49E-02  1.28E+00  6.40E-03  7.02E-01  1.91E-02  9.05E+02
CAL_DAT/ 5.13E+00  4.00E-03  3.81E+01  3.81E-02  1.66E+00  7.03E-03  7.02E-01  1.90E-02  9.89E+02
CAL_DAT/ 2.01E-01  4.00E-03  3.80E+01  2.19E-02  4.17E+00  1.88E-02  7.00E-01  1.90E-02  1.05E+03
CAL_DAT/ 3.49E+00  4.00E-03  3.80E+01  1.35E-02  2.03E+00  7.99E-03  7.02E-01  1.90E-02  1.14E+03
CAL_DAT/ 1.17E+01  4.00E-03  3.79E+01  3.60E-02  1.07E+00  6.00E-03  7.02E-01  1.90E-02  1.23E+03
CAL_DAT/ 1.34E+01  4.00E-03  3.80E+01  9.34E-03  9.96E-01  6.10E-03  7.02E-01  1.91E-02  1.26E+03
CAL_DAT/ 1.48E+01  4.00E-03  3.81E+01  8.88E-03  9.39E-01  5.99E-03  7.08E-01  1.91E-02  1.92E+03
CAL_TYPE: Constant Temperature
CALIBRATION: Pressure (P/Po), Normalized Intensity Ratio (I/I)
CAL_POIN 1.00E+00  1.01E+00
CAL_POIN 1.02E+00  1.02E+00
CAL_POIN 4.59E-01  6.46E-01
CAL_POIN 6.82E-01  8.05E-01
CAL_POIN 1.25E-01  3.54E-01
CAL_POIN 5.71E-01  7.28E-01
CAL_POIN 3.48E-01  5.59E-01
CAL_POIN 1.36E-02  2.23E-01
CAL_POIN 2.36E-01  4.60E-01
CAL_POIN 7.94E-01  8.71E-01
CAL_POIN 9.05E-01  9.35E-01
CAL_POIN 1.00E+00  1.00E+00
LIN_FITX 2.70E-01  7.50E-01  6.49E-04
QUAD_FIT 2.21E-01  1.04E+00 -2.61E-01  6.56E-05
LIN_FITX -3.50E-01  1.32E+00  1.14E-03
QUAD_FIT -1.46E-01  5.71E-01  5.73E-01  5.53E-05
    
```

Table D7. PSP Constant-Temperature, Variable-Pressure (53° F)

```

TITLE: PSPcal version 0.01+
HEADER: Start Time: 7/31/98 11:00:47 AM
SAMPLE_NPOINTS: 10000
SAMPLE_RATE: 1000.000000
CAL_NPOINTS: 12
CAL_NQUANTITIES: 9
DATA:  Pressure  stable_win  Temperatu std(T)    I_paint    std(I_paint) I_lamp    std(I_lamp) time(sec)
CAL_DAT/ 1.48E+01  4.00E-03  5.30E+01  1.26E-02  7.00E-01  5.57E-03  7.08E-01  1.89E-02  3.43E+02
CAL_DAT/ 1.85E+00  4.00E-03  5.30E+01  1.19E-02  2.12E+00  8.36E-03  7.08E-01  1.88E-02  5.24E+02
CAL_DAT/ 8.42E+00  4.00E-03  5.29E+01  3.73E-02  9.71E-01  6.20E-03  7.08E-01  1.88E-02  6.08E+02
CAL_DAT/ 6.78E+00  4.00E-03  5.30E+01  1.45E-02  1.09E+00  6.42E-03  7.08E-01  1.89E-02  6.86E+02
CAL_DAT/ 1.34E+01  4.00E-03  5.30E+01  1.31E-02  7.42E-01  5.75E-03  7.07E-01  1.90E-02  8.62E+02
CAL_DAT/ 3.49E+00  4.00E-03  5.30E+01  3.46E-02  1.56E+00  7.24E-03  7.06E-01  1.90E-02  1.03E+03
CAL_DAT/ 1.50E+01  4.00E-03  5.29E+01  2.43E-02  6.97E-01  5.98E-03  7.06E-01  1.89E-02  1.13E+03
CAL_DAT/ 5.13E+00  4.00E-03  5.32E+01  4.63E-02  1.26E+00  6.84E-03  7.04E-01  1.88E-02  1.22E+03
CAL_DAT/ 1.17E+01  4.00E-03  5.29E+01  1.46E-02  8.02E-01  5.89E-03  7.05E-01  1.89E-02  1.31E+03
CAL_DAT/ 1.01E+01  4.00E-03  5.30E+01  1.07E-02  8.70E-01  6.23E-03  7.08E-01  1.90E-02  1.56E+03
CAL_DAT/ 2.00E-01  4.00E-03  5.30E+01  1.14E-02  3.78E+00  1.28E-02  7.08E-01  1.88E-02  1.73E+03
CAL_DAT/ 1.48E+01  4.00E-03  5.30E+01  1.17E-02  6.99E-01  5.88E-03  7.08E-01  1.89E-02  1.91E+03
CAL_TYPE: Constant Temperature
CALIBRATION: Pressure (P/Po), Normalized Intensity Ratio (Io/I)
CAL_POIN 1.00E+00  9.99E-01
CAL_POIN 1.25E-01  3.29E-01
CAL_POIN 5.71E-01  7.20E-01
CAL_POIN 4.59E-01  6.40E-01
CAL_POIN 9.05E-01  9.39E-01
CAL_POIN 2.36E-01  4.45E-01
CAL_POIN 1.02E+00  1.00E+00
CAL_POIN 3.48E-01  5.49E-01
CAL_POIN 7.93E-01  8.68E-01
CAL_POIN 6.82E-01  8.02E-01
CAL_POIN 1.36E-02  1.85E-01
CAL_POIN 1.00E+00  1.00E+00
LIN_FITYX 2.45E-01  7.74E-01  1.01E-03
QUAD_FIT 1.84E-01  1.14E+00  -3.32E-01  6.64E-05
LIN_FITXY -3.04E-01  1.27E+00  1.66E-03
QUAD_FIT -9.15E-02  4.44E-01  6.55E-01  2.04E-05
    
```

Table D8. PSP Constant-Temperature, Variable-Pressure (68° F) Repeated

```

TITLE: PSPcal version 0.01+
HEADER: Start Time: 7/31/98 9:03:18 AM
SAMPLE_NPOINTS: 10000
SAMPLE_RATE: 1000.000000
CAL_NPOINTS: 12
CAL_NQUANTITIES: 9
DATA:  Pressure  stable_wini  Temperatu std(T)  I_paint  std(I_paint)  I_lamp  std(I_lamp)  time(sec)
CAL_DAT/ 1.48E+01  4.00E-03  6.80E+01  1.30E-02  6.11E-01  5.32E-03  6.94E-01  1.89E-02  3.03E+02
CAL_DAT/ 8.42E+00  4.00E-03  6.80E+01  1.18E-02  8.55E-01  5.16E-03  6.95E-01  1.87E-02  4.73E+02
CAL_DAT/ 1.34E+01  4.00E-03  6.80E+01  2.66E-02  6.50E-01  4.83E-03  6.94E-01  1.86E-02  5.25E+02
CAL_DAT/ 1.50E+01  4.00E-03  6.80E+01  1.63E-02  6.05E-01  4.68E-03  6.95E-01  1.87E-02  6.73E+02
CAL_DAT/ 1.17E+01  4.00E-03  6.80E+01  2.42E-02  6.99E-01  4.81E-03  6.95E-01  1.86E-02  7.30E+02
CAL_DAT/ 1.85E+00  4.00E-03  6.81E+01  8.14E-02  1.98E+00  7.70E-03  6.95E-01  1.86E-02  7.92E+02
CAL_DAT/ 3.49E+00  4.00E-03  6.79E+01  3.17E-02  1.42E+00  6.28E-03  6.95E-01  1.85E-02  8.76E+02
CAL_DAT/ 6.78E+00  4.00E-03  6.80E+01  1.40E-02  9.72E-01  5.30E-03  6.96E-01  1.86E-02  9.11E+02
CAL_DAT/ 5.13E+00  4.00E-03  6.80E+01  1.43E-02  1.14E+00  6.20E-03  6.97E-01  1.88E-02  9.84E+02
CAL_DAT/ 2.00E-01  4.00E-03  6.80E+01  1.07E-02  4.12E+00  1.43E-02  6.96E-01  1.87E-02  1.14E+03
CAL_DAT/ 1.01E+01  4.00E-03  6.80E+01  1.05E-02  7.63E-01  6.21E-03  6.97E-01  1.87E-02  1.31E+03
CAL_DAT/ 1.48E+01  4.00E-03  6.79E+01  3.94E-02  6.10E-01  5.81E-03  6.97E-01  1.89E-02  1.39E+03
CAL_TYPE: Constant Temperature
CALIBRATION: Pressure (P/Po), Normalized Intensity Ratio (I/I)
CAL_POIN 1.00E+00  9.92E-01
CAL_POIN 5.71E-01  7.10E-01
CAL_POIN 9.05E-01  9.33E-01
CAL_POIN 1.02E+00  1.00E+00
CAL_POIN 7.94E-01  8.68E-01
CAL_POIN 1.25E-01  3.07E-01
CAL_POIN 2.36E-01  4.27E-01
CAL_POIN 4.59E-01  6.26E-01
CAL_POIN 3.48E-01  5.35E-01
CAL_POIN 1.36E-02  1.48E-01
CAL_POIN 6.82E-01  7.99E-01
CAL_POIN 1.00E+00  1.00E+00
LIN_FITYX 2.18E-01  8.03E-01  1.23E-03
QUAD_FIT 1.50E-01  1.21E+00 -3.64E-01  9.37E-05
LIN_FITXY -2.57E-01  1.23E+00  1.87E-03
QUAD_FIT -6.66E-02  4.37E-01  6.39E-01  2.31E-05
    
```

Table D9. PSP Constant-Temperature, Variable-Pressure (68° F) Repeated

```

TITLE: PSPcal version 0.01+
HEADER: Start Time: 7/28/98 3:10:56 PM
SAMPLE_NPOINTS: 10000
SAMPLE_RATE: 1000.000000
CAL_NPOINTS: 12
CAL_NQUANTITIES: 9
DATA:  Pressure  stable_win  Temperatu std(T)    I_paint   std(I_paint) I_lamp   std(I_lamp) time(sec)
CAL_DAT/ 1.47E+01  4.00E-03  6.81E+01  5.11E-02  7.98E-01  5.55E-03  6.91E-01  1.90E-02  3.03E+02
CAL_DAT/ 1.01E+01  4.00E-03  6.80E+01  1.05E-02  8.56E-01  4.88E-03  6.90E-01  1.84E-02  4.73E+02
CAL_DAT/ 1.17E+01  4.00E-03  6.80E+01  1.27E-02  8.47E-01  4.85E-03  6.91E-01  1.83E-02  5.41E+02
CAL_DAT/ 5.13E+00  4.00E-03  6.79E+01  2.69E-02  1.13E+00  7.39E-03  6.90E-01  1.85E-02  7.22E+02
CAL_DAT/ 3.49E+00  4.00E-03  6.81E+01  7.25E-02  1.35E+00  9.80E-03  6.90E-01  1.85E-02  8.11E+02
CAL_DAT/ 1.85E+00  4.00E-03  6.81E+01  3.37E-02  1.48E+00  1.49E-02  6.90E-01  1.86E-02  8.43E+02
CAL_DAT/ 1.50E+01  4.00E-03  6.80E+01  1.34E-02  7.42E-01  4.71E-03  6.91E-01  1.83E-02  1.16E+03
CAL_DAT/ 6.78E+00  4.00E-03  6.80E+01  2.48E-02  8.97E-01  5.44E-03  6.92E-01  1.84E-02  1.35E+03
CAL_DAT/ 8.42E+00  4.00E-03  6.80E+01  1.46E-02  9.10E-01  4.90E-03  6.93E-01  1.84E-02  1.39E+03
CAL_DAT/ 2.00E-01  4.00E-03  6.79E+01  5.50E-02  1.86E+00  2.50E-02  6.90E-01  1.86E-02  1.58E+03
CAL_DAT/ 1.34E+01  4.00E-03  6.80E+01  1.73E-02  8.01E-01  5.01E-03  6.93E-01  1.85E-02  1.87E+03
CAL_DAT/ 1.47E+01  4.00E-03  6.80E+01  1.21E-02  7.58E-01  5.26E-03  6.94E-01  1.91E-02  1.92E+03
CAL_TYPE: Constant Temperature
CALIBRATION: Pressure (P/Po), Normalized Intensity Ratio (Io/I)
CAL_POIN 1.00E+00  9.45E-01
CAL_POIN 6.84E-01  8.81E-01
CAL_POIN 7.96E-01  8.91E-01
CAL_POIN 3.49E-01  6.69E-01
CAL_POIN 2.37E-01  5.60E-01
CAL_POIN 1.26E-01  5.09E-01
CAL_POIN 1.02E+00  1.02E+00
CAL_POIN 4.61E-01  8.42E-01
CAL_POIN 5.73E-01  8.31E-01
CAL_POIN 1.36E-02  4.05E-01
CAL_POIN 9.08E-01  9.44E-01
CAL_POIN 1.00E+00  1.00E+00
LIN_FITYX 4.63E-01  5.49E-01  2.65E-03
QUAD_FIT 3.83E-01  1.03E+00 -4.30E-01  1.06E-03
LIN_FITXY -7.43E-01  1.69E+00  8.17E-03
QUAD_FIT 1.41E-01 -9.80E-01  1.85E+00  5.10E-03
    
```

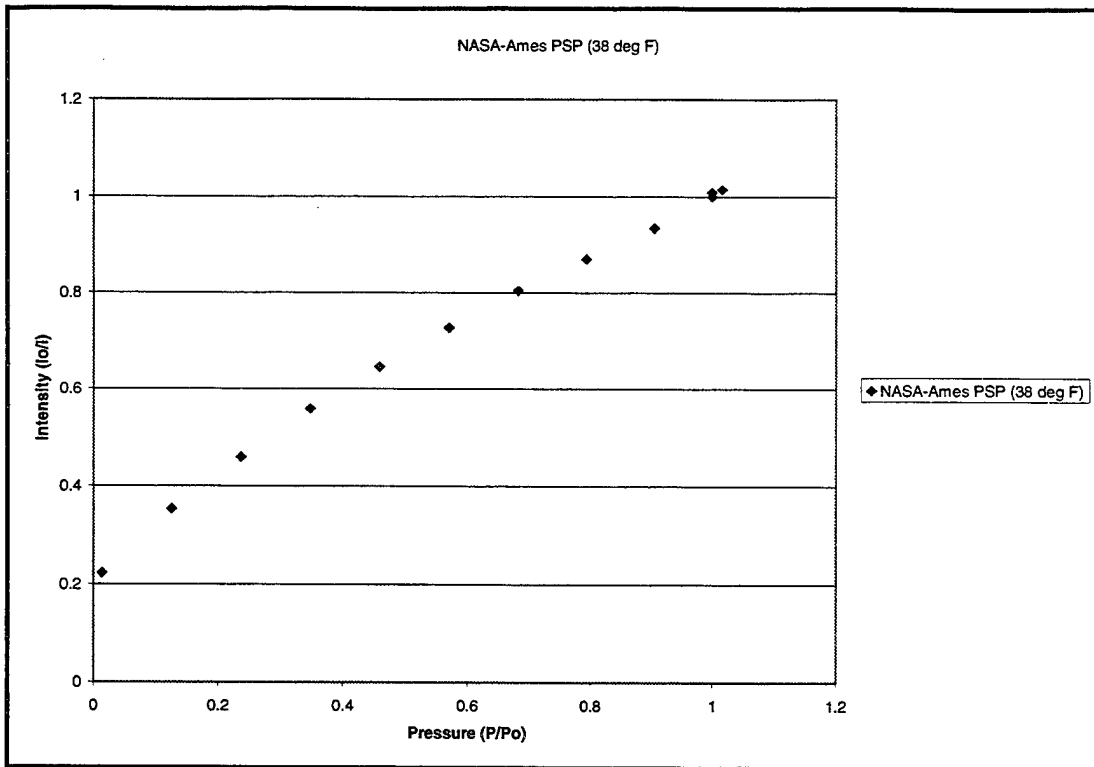

Figure D1. NASA-Ames PSP Calibration at 38° F

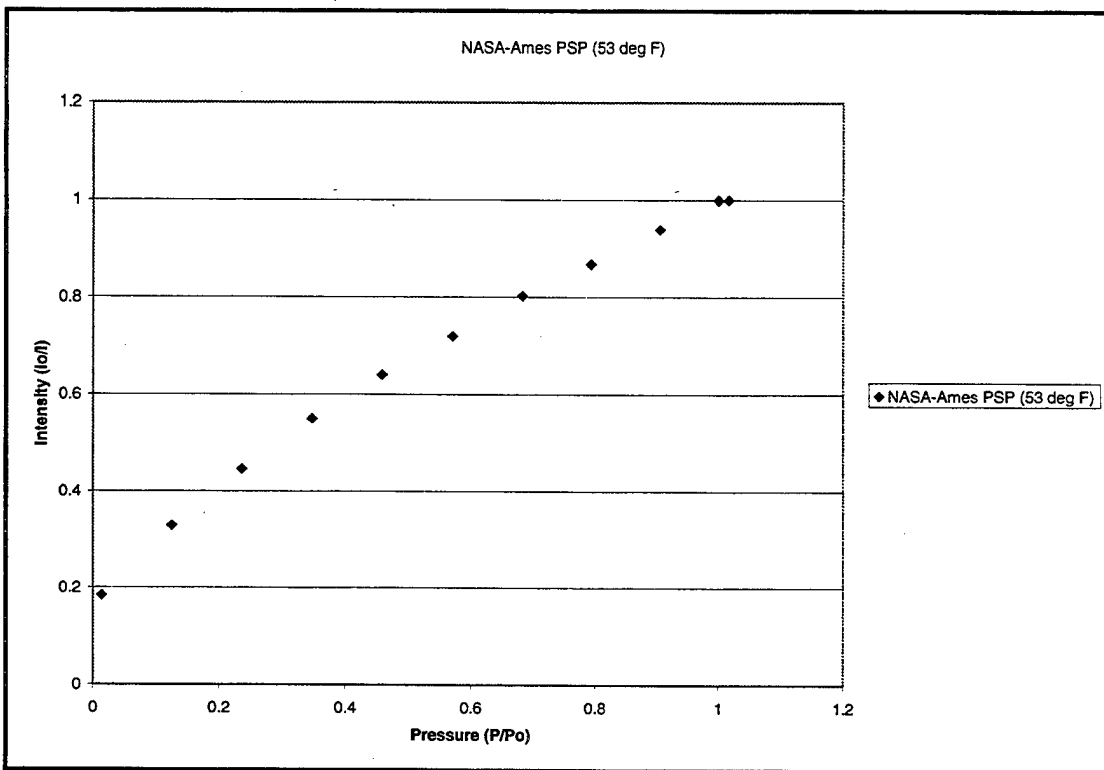

Figure D2. NASA-Ames PSP Calibration at 53° F

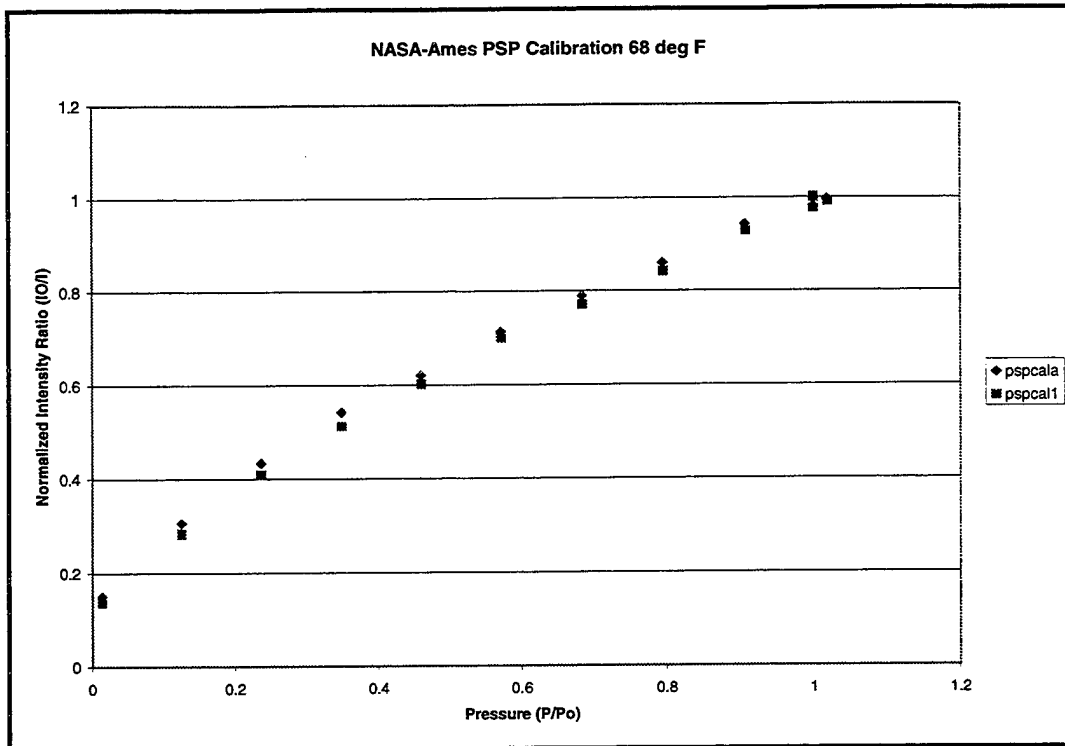

Figure D3. NASA-Ames PSP Calibration at 68° F

APPENDIX E. WOODMANSEE DATA

Table E1. Woodmansee Data [Ref. 8] Conversion ($^{\circ}\text{C}$ to $^{\circ}\text{F}$)

Woodmansee/Dutton PtOEP Experiment		
Temp $^{\circ}\text{C}$	Temp $^{\circ}\text{F}$	Iref/Ical = I _o /I
0	32	0.725
3	37.4	0.807
6	42.8	0.9
9	48.2	1.05
12	53.6	1.11
15	59	1.25
18	64.4	1.38
21	69.8	1.55

Table E2. Extrapolation and I_{Ref} change to 70 $^{\circ}\text{F}$ of Woodmansee Data [Ref. 8]

Temp ($^{\circ}\text{F}$)	Iref/Ical extrapolation $y=0.0002*(x)*(x)+0.0036*(x)+0.4314$	(1/Iref)	Iref(70 $^{\circ}\text{F}$)/Ical
32	0.7514	1.330849	0.451725
37.4	0.845792	1.182324	0.508472
42.8	0.951848	1.050588	0.57223
48.2	1.069568	0.934957	0.643001
53.6	1.198952	0.834062	0.720784
59	1.34	0.746269	0.805579
64.4	1.492712	0.669922	0.897386
69.8	1.657088	0.603468	0.996205
70	1.6634	0.601178	0.999999
80	1.9994	0.50015	1.201995
85	2.1824	0.458211	1.312011
100	2.7914	0.358243	1.678128
120	3.7434	0.267137	2.25045
125	4.0064	0.249601	2.40856
130	4.2794	0.233678	2.572681
135	4.5624	0.219183	2.742815
145	5.1584	0.193859	3.101117
153	5.664	0.176554	3.405072

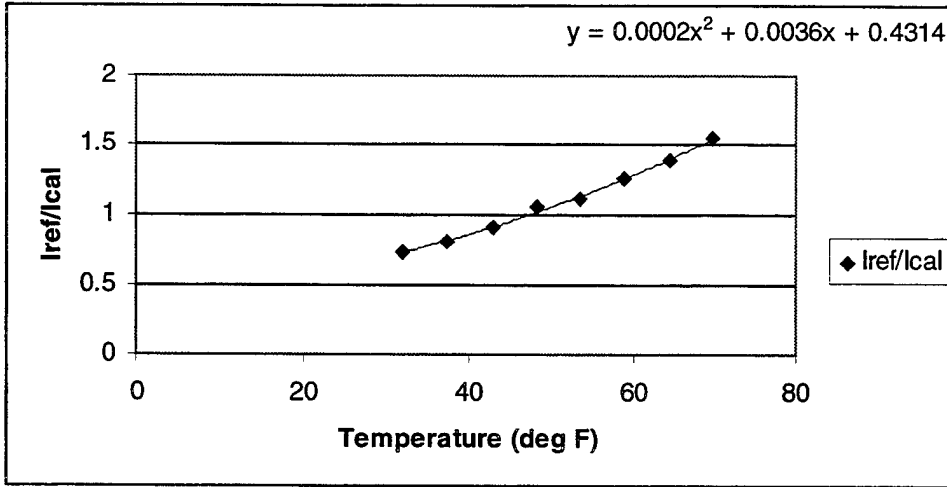

Figure E1. Original Woodmansee Data From [Ref. 8]

**APPENDIX F. INDIVIDUAL LINEAR AND QUADRATIC CURVE
FIT FIGURES**

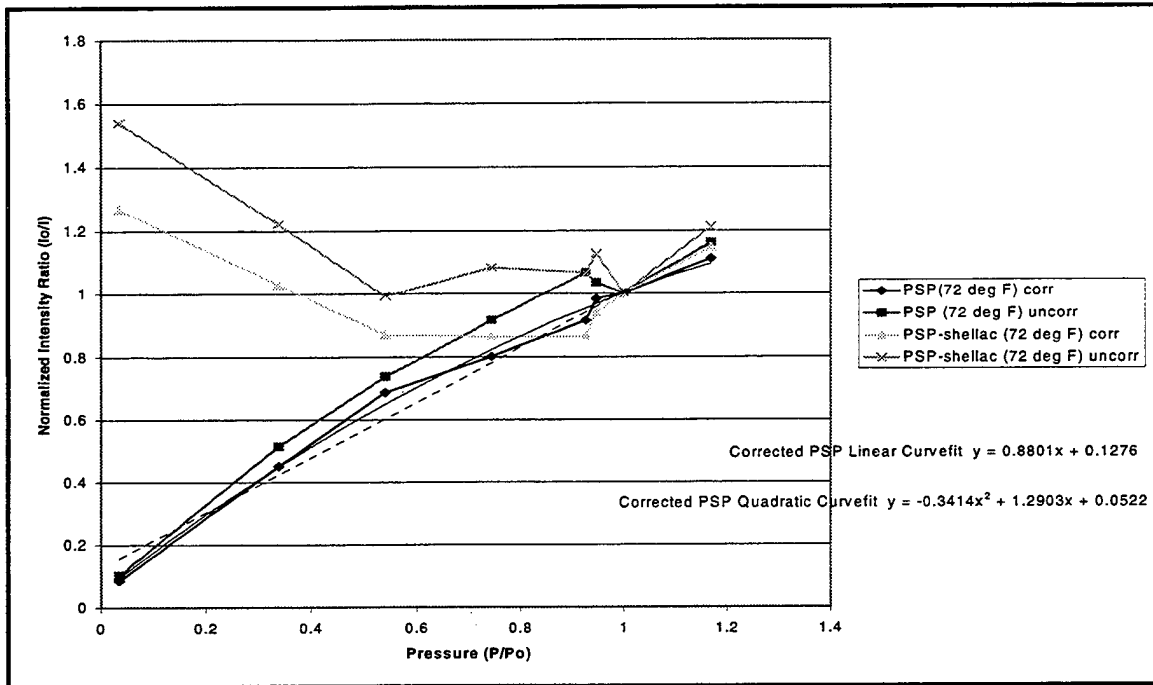

Figure F1. AC-5 Constant-Temperature, Variable-Pressure (72⁰ F)

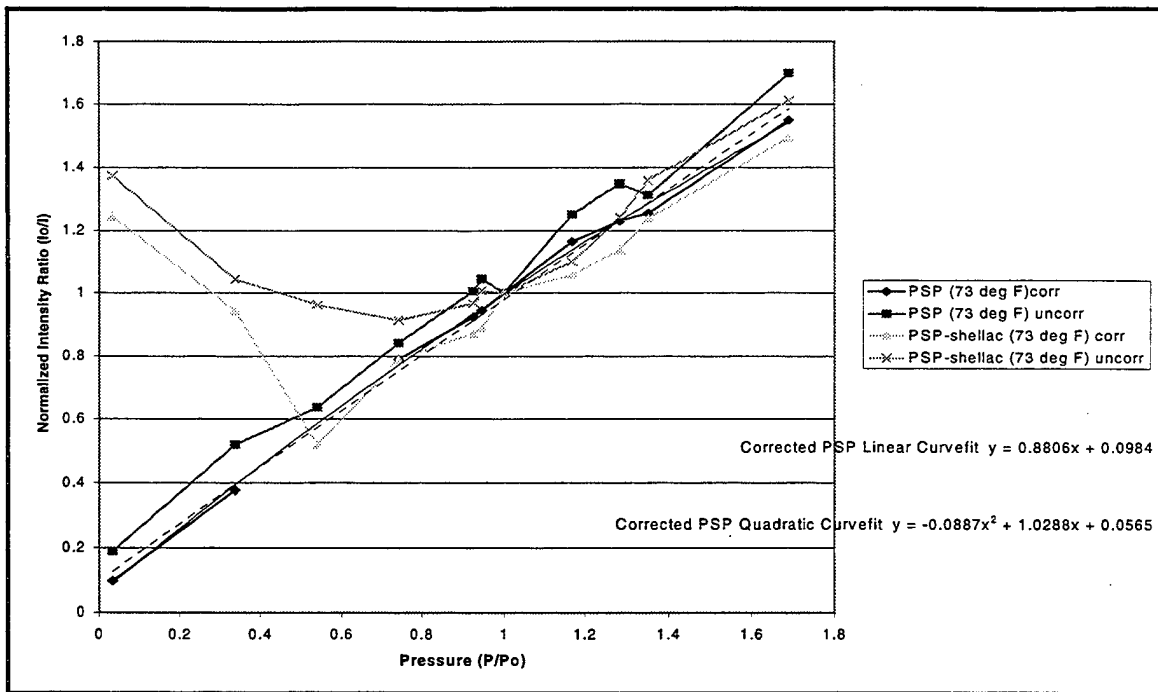

Figure F2. AC-6 Constant-Temperature, Variable-Pressure (73⁰ F)

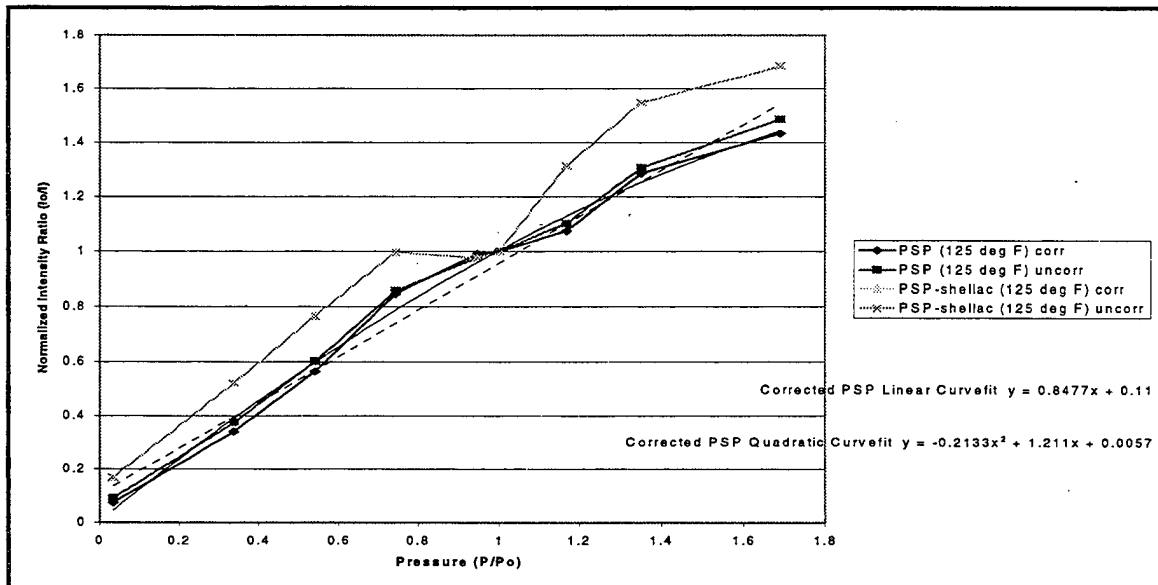

Figure F3. AC-8 Constant-Temperature, Variable-Pressure (125⁰ F)

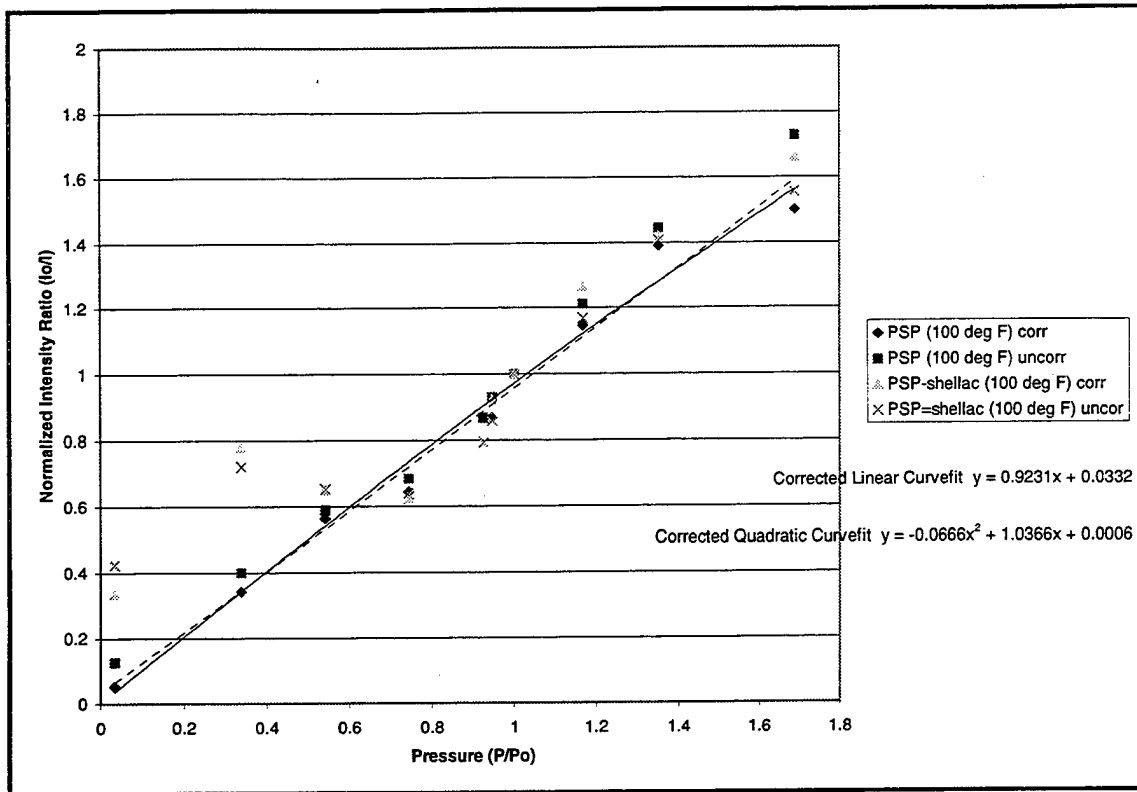

Figure F4. AC-9 Constant-Temperature, Variable-Pressure (100° F)

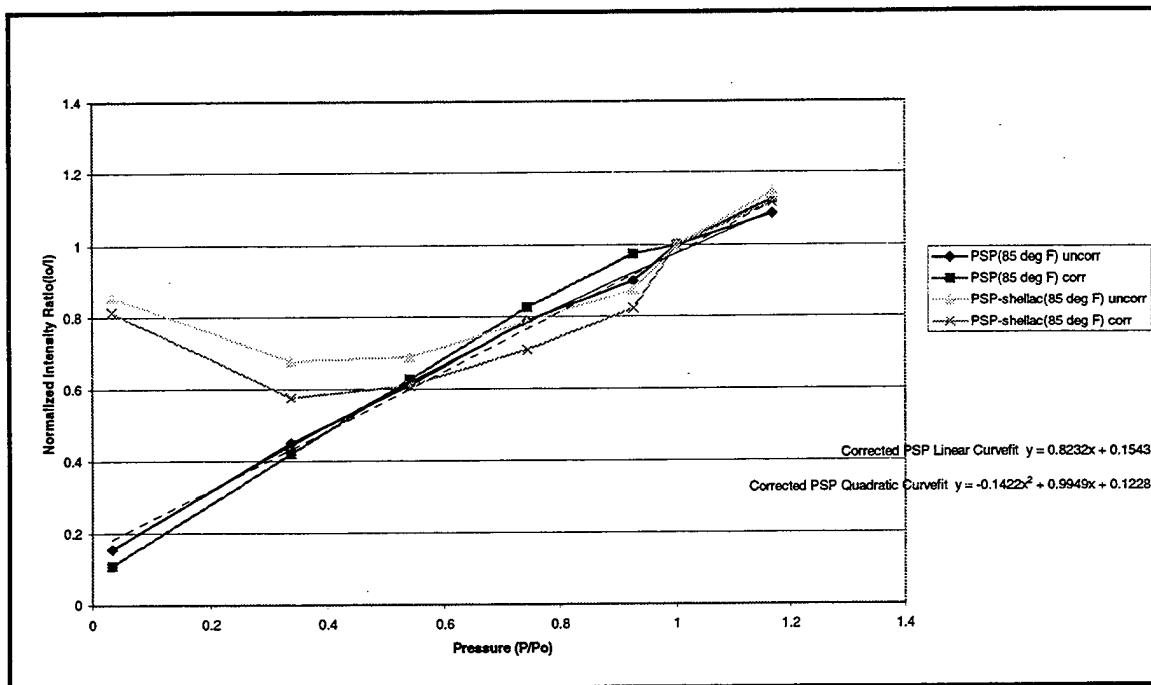

Figure F5. AC-10 Constant-Temperature, Variable-Pressure (85° F)

APPENDIX G. TEST ROTOR MODIFICATIONS

The test rotor for PSP development is fully described by Gahagan [Ref. 6]. The setup was modified to include a helium-neon laser rather than an LED to activate the once-per-revolution trigger. The helium-neon laser was a Uniphase Model #1105, with a 632.8 nm wavelength. The laser was powered by a Uniphase Power Supply Model #1202-1, and held by a Model 813 Laser mount. The test rotor with the laser modification and the cover plate removed is shown in Figure G1. The laser was used to increase the signal strength so that a rotor speed up to 30,000 rpm

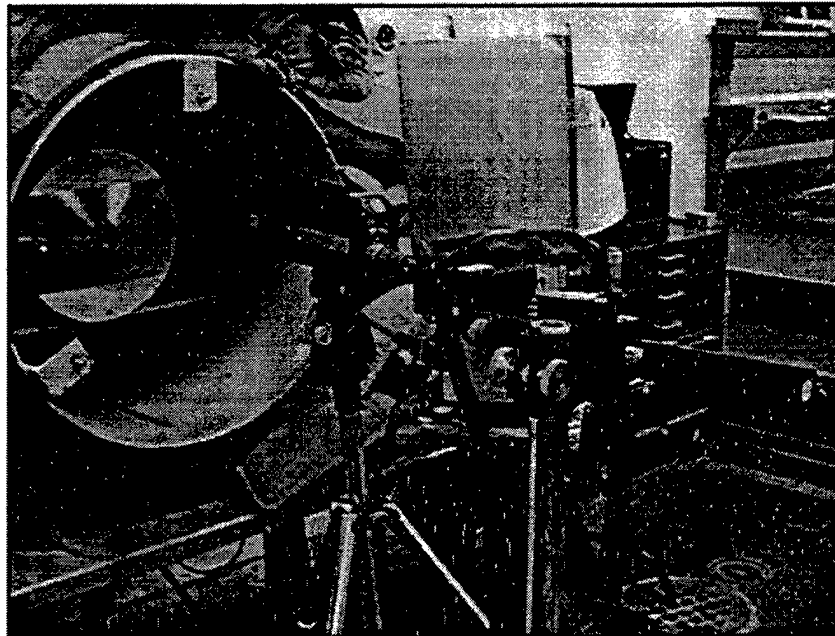

Figure G1. Test Rotor with Laser Modification

could be achieved without loss of the rpm signal, as was reported in Gahagan [Ref. 6]. The positioning of the laser on the left side to activate the once-per-revolution signal required the repositioning of the Oriel lamp from its original location. The temperature of the “wind-on” rotor and the “wind-off” rotor were taken using an Omega Model HH21 microprocessor thermometer with a type K thermocouple sensor. The sensor was placed on the surface of the test rotor as soon as the test rotor stopped for the “wind-on” condition. The test rotor was operated to 20,000 rpm, images

were acquired and temperatures were recorded as shown in Table G1. In a second test, the rotor was also successfully operated at 30,000 rpm to verify the rpm signal, and to demonstrate paint adherence to full speed. No paint stripping occurred at speeds up to 30,000 rpm. This success was the result of leaving the white undercoat too completely dry for at least 4 hours under a heat lamp, before applying PSP in the same way as Gahagan [Ref. 6].

Table G1. Test Rotor Test Conditions

Test Speed (rpm)	Test Speed (Hz)	Ambient Temperature(°F)	Wind-On Temperature (°F)
19,980	333	72.7	102.7

LIST OF REFERENCES

1. Navarra, K.R., Jordan, J.D., Trump, D.D., Stange, W.A., "Recent Developments in Optical Surface Pressure Measurements", Paper Presented at the 3rd National Turbine Engine High Cycle Fatigue Conference, San Antonio, Texas, February 2-5, 1998.
2. Bencic, T.J., "Rotating Pressure and Temperature Measurements on Scale-Model Fans Using Luminescent Paints", AIAA Paper No. 98-3452, Presented at the 34th AIAA/ASME/SAE/ASEE Joint Propulsion Conference & Exhibition, Cleveland, Ohio, July 13-15, 1998.
3. Quinn, K.J., "Pressure-Sensitive Paint Measurement Technique Development for Turbomachinery Application", Master's Thesis, Naval Postgraduate School, Monterey, California, December 1997.
4. McLachlan, B.G., Kavandi, J.L., Callis, J.B., Gouterman, M., Green, E., Khalil, G., Burns, D., "Surface Pressure Field Mapping Using Luminescent Coatings", *Experiments in Fluids*, Vol.14, pp.33-41, 1993.
5. Grossman, B.L., "Testing and Analysis Of A Transonic Axial Compressor", Master's Thesis, Naval Postgraduate School, Monterey, California, September 1997.
6. Gahagan, S.G., "Pressure-Sensitive Paint Measurements On A Rotor Disk Surface At High Speeds", Master's Thesis, Naval Postgraduate School, Monterey, California, June 1997.

7. Shreeve, R.P., *Unpublished Notes*, Naval Postgraduate School, Monterey, California, September 1998.
8. Woodmansee, M.A., and Dutton, J. C., "Methods For Treating Temperature Sensitive Effects of Pressure-Sensitive Paints", AIAA Paper No. 97-0387, Presented at the 35th Aerospace Sciences Meeting & Exhibit, Reno, Nevada, January 6-10, 1997.
9. Morris, M.J., Donovan, J.F., Kegelman, J.T., Schwab, S.D., Levy, R.L., Crities, R.C., "Aerodynamic Applications of Pressure Sensitive Paint", AIAA Paper No. 92-0264, Presented at the 30th Aerospace Sciences Meeting & Exhibit, Reno, Nevada, January 6-9, 1992.
10. Willard, H.H., Meritt, L.L., and Dean, J. A., "Instrumental Methods of Analysis", D. Van Nostrand Company, New York, 1974, pp. 133-136.
11. Kavandi, J.L., Callis, J.B., Gouterman, M., Khalil, G., Wright, D., Green, E., Burns, D. and McLachlan, B.G., "Luminescent Barometry in Wind Tunnels", *Rev. Sci. Instruments*, Vol. 61, No. 5, pp. 3340-3347, November 1990.
12. Navarra, K.R., Goss, L.P., Grinsbad, K.D., Jordan, J.D., Rabe, D.C., Gord, J.R., Car, D., "Optical Measurements of Surface Pressure and Temperature in Turbomachinery", Paper Presented at the Research and Technology Organization 90th Meeting and Symposium of the Propulsion and Energetics Panel on Advanced Non-Intrusive

Instrumentation for Propulsion Engines, Brussels, Belgium, October 1997.

13. Varner, D.R., "Pressure Sensitive Paint Measurement On A Rotor", Master's Thesis, Naval Postgraduate School, Monterey, California, March 1995.
14. Bell, J. H., NASA-Ames Research Center, Private Conversation, July 16, 1998.
15. Seivwright, D.L., "Application of Pressure-Sensitive Paint In Shock-Boundary Layer Interaction Experiments", Master's Thesis, Naval Postgraduate School, Monterey, California, March 1996.
16. Shreeve, R.P., and Neuhoff, F., "Measurements of the Flow From a Compressor Rotor Using a Dual Probe Digital Sampling (DPDS) Technique," ASME Journal of Engineering for Gas Turbines and Power, Vol. 106, No. 2, pp. 366-375, April 1984.

INITIAL DISTRIBUTION LIST

	No. of Copies
1. Defense Technical Information Center.....	2
8725 John J. Kingman Rd., Ste 0944	
Ft. Belvoir, VA 22060-6218	
2. Dudley Knox Library	2
Naval Postgraduate School	
411 Dyer Rd.	
Monterey, CA 93943-5101	
3. Department Chairman, Code AA	1
Department of Aeronautics and Astronautics	
Naval Postgraduate School	
699 Dyer Road, Rm. 137	
Monterey, CA 93943-5107	
4. Dr. Raymond P. Shreeve, Code AA/SF.....	5
Department of Aeronautics and Astronautics	
Naval Postgraduate School	
699 Dyer Road, Rm. 137	
Monterey, CA 93943-5107	
5. Dr. Garth V. Hobson, Code AA/HG	1
Department of Aeronautics and Astronautics	
Naval Postgraduate School	
699 Dyer Road, Rm. 137	
Monterey, CA 93943-5107	

- 6. Curricular Officer, Code 31.....1
 Naval Postgraduate School
 Monterey, CA 93943-5002

- 7. Naval Air Warfare Center..... 1
 AIR-4.4.T (Attn: Mr. C. Gordon)
 Propulsion and Power Engineering, Building 106
 Patuxent River, MD 20670-5304

- 8. Naval Warfare Center Aircraft Division..... 1
 AIR-4.4.3.1 (Attn: S. McAdams)
 Propulsion and Power Engineering, Building 106
 Patuxent River, MD 20670-5304

- 9. CDR Peter D. Baumann..... 1
 4496 Caminito Cristalino
 San Diego, CA. 92117