

CONTRACT NUMBER DAMD17-94-C-4154

TITLE: WRAIR GOCO Blood Research Detachment's Red Blood Cell Storage Laboratory

PRINCIPAL INVESTIGATOR: Lloyd E. Lippert, Ph.D.

CONTRACTING ORGANIZATION: Bionetics Corporation  
Hampton, Virginia 23669

REPORT DATE: October 1998

TYPE OF REPORT: Annual

PREPARED FOR: Commander  
U.S. Army Medical Research and Materiel Command  
Fort Detrick, Frederick, Maryland 21702-5012

DISTRIBUTION STATEMENT: Approved for public release;  
Distribution unlimited

19981204 058

The views, opinions and/or findings contained in this report are those of the author(s) and should not be construed as an official Department of the Army position, policy or decision unless so designated by other documentation.

**Reproduced From  
Best Available Copy**

# REPORT DOCUMENTATION PAGE

Form Approved  
OMB No. 0704-0188

Public reporting burden for this collection of information is estimated to average 1 hour per response, including the time for reviewing instruction, searching existing data sources, gathering and maintaining the data needed, and completing and reviewing the collection of information. Send comments regarding this burden estimate or any other aspect of this collection of information, including suggestion for regarding this burden, to Washington Headquarters Services, Directorate for Information Operations and Reports, 1215 Jefferson Davis Highway, Suite 1204, Arlington, VA 22202-4302, and to the Office of Management and Budget, Paperwork Reduction Project (0704-D188), Washington, D.C. 20503.

<b>1. AGENCY USE ONLY (Leave blank)</b>	<b>2. REPORT DATE</b> October 1998	<b>3. REPORT TYPE AND DATES COVERED</b> Annual (21 Sep. 97 - 20 Sep. 98)	
<b>4. TITLE AND SUBTITLE</b> WRAIR GOCO Blood Research Detachment's Red Blood Cell Storage Laboratory		<b>5. FUNDING NUMBERS</b> DAMD17-94-C-4154	
<b>6. AUTHOR(S)</b> Lloyd E. Lippert, Ph.D.			
<b>7. PERFORMING ORGANIZATION NAME(S) AND ADDRESS(ES)</b> Bionetics Corporation Newport News, Virginia 23606		<b>8. PERFORMING ORGANIZATION REPORT NUMBER</b>	
<b>9. SPONSORING/MONITORING AGENCY NAME(S) AND ADDRESS(ES)</b> Commander U.S. Army Medical Research and Materiel Command Fort Detrick, Frederick, MD 21702-5012		<b>10. SPONSORING/MONITORING AGENCY REPORT NUMBER</b>	
<b>11. SUPPLEMENTARY NOTES</b>			
<b>12a. DISTRIBUTION / AVAILABILITY STATEMENT</b> Approved for public release; distribution unlimited		<b>12b. DISTRIBUTION CODE</b>	
<b>13. ABSTRACT (Maximum 200 words)</b>  The Bionetics Corporation staffed and maintained a laboratory to support red blood cell preservation research at the Blood Research Detachment, Walter Reed Army Medical Center, 1413 Research Blvd., Rockville, MD 20850. Contract staff completed a clinical trial evaluating the effect of warming packed red blood cell units for 24 hours at 25°C both early and late in storage. Based on results of 24 hour posttransfusion survival of autologous red cells in normal volunteers and ATP concentration in stored blood, it is estimated that 24-hour period of warmed storage accelerates the deterioration of blood equivalent to 12 days of refrigerated storage in additive solution AS-5. Contract staff also completed a single <i>in vitro</i> trial and began a second. The completed trial measured the effect of storing red cells in excess amounts of additive solution AS-1 and produced unexpected results. Excess additive solution, rather than supporting higher ATP concentrations, resulted in lower concentrations after three weeks of storage. The second trial evaluates the properties of red cells stored in two experimental additive solutions; the trial was incomplete and no data analysis was available at the conclusion of the reporting period. The Bionetics Corporation advanced the Blood Research Detachment's mission.			
<b>14. SUBJECT TERMS</b> Red Blood Cell Preservation, Red Blood Cell Survival		<b>15. NUMBER OF PAGES</b> 55	
		<b>16. PRICE CODE</b>	
<b>17. SECURITY CLASSIFICATION OF REPORT</b> Unclassified	<b>8. SECURITY CLASSIFICATION OF THIS PAGE</b> Unclassified	<b>19. SECURITY CLASSIFICATION OF ABSTRACT</b> Unclassified	<b>20. LIMITATION OF ABSTRACT</b> Unlimited

FOREWORD

Opinions, interpretations, conclusions and recommendations are those of the author and are not necessarily endorsed by the U.S. Army.

     Where copyrighted material is quoted, permission has been obtained to use such material.

     Where material from documents designated for limited distributions is quoted, permission has been obtained to use the material.

     Citations of commercial organizations and trade names in this report do not constitute an official Department of Army endorsement or approval of the product or services of these organizations.

     In conducting research using animals, the investigator(s) adhered to the "Guide for the Care and Use of Laboratory Animal of the Institute of Laboratory Resources, National Research Council (NIH Publication No. 86-23, Revised 1985).

     For the protection of human subject, the investigator(s) adhered to policies of applicable of Federal Law 45 CRF 46.

     In conducting research utilizing recombinant DNA technology, the investigator(s) adhered to current guidelines promulgated by the National Institutes of Health.

     In the conduct of research utilizing recombinant DNA, the investigator(s) adhered to the NIH Guidelines for Research Involving Recombinant DNA Molecules.

     In conduct of research involving hazardous organisms, the investigator(s) adhered to the CDC-NIH Guide for Biosafety in Microbiological and Biomedical Laboratories.

  
PI - Signature

29 October 1998  
Date

## Table of Contents

Front Cover .....	1
Report Documentation Page (SF 298) .....	2
Foreword .....	3
Table of Contents .....	4
Introduction .....	6
The Purpose of the Present Work .....	7
A. "Phlebotomy Procedures for Use on Human Subjects" WRAIR #514, HURRAD Log #A-6664.	
Background .....	8
Methods .....	8
Results .....	8
Discussion / Conclusion .....	9
B. "Evaluation of the <i>in vivo</i> Viability of Red Blood Cells Stored for Prolonged Period in the Leukotrap® RC AS-24 System" WRAIR #572, HURRAD Log #A-6986.	
Background .....	9
Methods .....	10
Results .....	10
Discussion / Conclusion .....	10
C. "Evaluation of the <i>in vivo</i> Viability of Red Blood Cells Stored for Eight Weeks in the Leukotrap® Whole Blood AS-3 System" WRAIR #591, HURRAD Log #A-7089.	
Background .....	10
Methods .....	10
Results .....	11
Discussion / Conclusion .....	11
D. "Evaluation of the <i>in vitro</i> and <i>in vivo</i> Viability of Red Blood Cells Stored in Blood Storage Solutions CPDA-1 for 35 Days and in AS-5 for 42 Days at 1-6 C and Exposed for Short Periods to Higher Temperature" WRAIR #633, HURRAD Log #A-7818.	
Background .....	11
Methods .....	12
Results .....	12
Discussion / Conclusion .....	12
E. "Psoralen Sterilization of Platelet Concentrates Infected with <i>Orentia tsutsugamushi</i> "	
Background .....	12
Methods .....	12
Results .....	12
Discussion / Conclusion .....	13
General and Administrative .....	13
Conclusion .....	13
References .....	14
Appendices	
1. List of Personnel .....	17

2. Manuscript “An Improved Process for the Production of Sterile Modified Haemoglobin Solutions” .....	18
3. Manuscript “ Effect of 24 Hours of Storage at 25° Centigrade on the <i>in vitro</i> Storage Characteristics of CPDA-1 Packed Red Blood Cells”....	30
4. Manuscript “The Viability of Autologous Human Red Blood Cells Stored in Additive Solution-5 and Exposed to 25°C for 24 Hours” .....	35
5. Data Graph .....	54
6. Data Graph .....	55

# ANNUAL REPORT: DAMD94-C-4154

## INTRODUCTION

### Nature of the Problem:

Because combat is synonymous with bloodshed and blood replacement saves lives, the US Army Medical Research and Materiel Command maintains facilities and programs to develop improved blood products.

### The Background of the Previous Work:

The US Army has, for decades, conducted research in red blood cell preservation and the production of acellular hemoglobin solutions for use in combat casualty care. From 1974 through 1992, that research took place at the Letterman Army Institute of Research (LAIR) located at the Presidio. The LAIR facility was closed as the result of Base Realignment and Closure actions and the Blood Research Detachment was relocated to leased laboratory space at 1413 Research Blvd., Rockville, Maryland. On 19 September 1994 The Bionetics Corporation (TBC) was awarded a contract to operate and maintain equipment and provide technical support to the Blood Research Detachment. For the first two years of the contract, the contractors supported the Hemoglobin Production Facility (HPF) and integral analytical chemistry laboratory which provided quality control and characterization testing. The HPF produced several hundred liters of a precision hemoglobin based blood substitute material for research. The acellular hemoglobin solutions manufactured by the HPF were based on biochemical modification of stroma-free hemoglobin as described in the literature.<sup>1,2,3 and 4</sup> A detailed description of the hemoglobin solution production process and process improvements is contained a manuscript, published in October 1997 by the journal "Biologics", the journal of the International Association of Biological Standardization. A reprint copy of the article is attached as Appendix 1. During the last several months of HPF operation, the contract staff also supported the US Navy liposome encapsulated hemoglobin research.<sup>5,6</sup> HPF related activities were terminated on 20 September 1996 and the facility closed.

Contract staff has continuously operated and maintained the blood cell preservation research of the Blood Storage Laboratory (BSL), a fully equipped red cell research laboratory currently staffed by 3 full-time and 2 part-time employees. The Blood Banking Specialist member of this team is also the Project Manager. A list of contract staff as of the close of the FY is included at Appendix 1.

The currently Food and Drug Administration (FDA) licensed anticoagulant, preservative solutions allows storage of red blood cells at 4°C for 42 days after collection. Work by Meryman *et. al.*<sup>7,8</sup> and Greenwalt, Dumaswala and colleagues<sup>9,10</sup> indicates potential for extended storage. Greenwalt and colleagues have recently developed experimental additive solution which preserves red cells for 63<sup>11,12</sup> days with average red cell survival at least 75%.

It is estimated that 1 million units of blood expire per year in the United States. It is further estimated that if expiration were extended to 9 weeks, one-third of the expired units now

discarded would be transfused.<sup>13</sup> Extended shelf-life of liquid stored blood would have significant utility to the Armed Services Blood Program as it supports the Department of Defense blood transfusion requirements world-wide. The major advantages of an nine-week extended shelf life red cell product include, reducing resupply requirements by up to 50%, reducing the blood collection requirements to replace outdated products, and increasing the practicality of rotating aged but unexpired red cell products from the theater of operations to CONUS treatment facilities where they are more likely to be used. The net result is reduced costs through enhanced utilization of a scarce, perishable resource.

#### The Purpose of the Present Work:

The BSL evaluates the effectiveness of candidate red blood cell anticoagulant preservative systems and storage strategies and their potential for further development. Much of the work is done in conjunction with other principal investigators in the BRD, WRAIR. The BRD supports the Military Blood Program by providing data which will evaluate the safety, effectiveness, and practicality of new products or procedures related to the collection, processing and distribution of red blood cells. The Blood Research Detachment has agreed to participate with the Naval Blood Research Laboratory, Boston, MA, in the evaluation of an automated system to glycerolize red blood cells for frozen storage and deglycerolize the thawed cells in preparation for transfusion. The system, developed by the Haemonetics Corporation, has two major potential advantages over existing systems. First, the system is functionally "closed" as defined by the Food and Drug Administration which, thereby, permits post-deglycerolization storage beyond the 24 hour limit imposed on "open" systems. All current systems are "open" and consequently the red cells prepared in existing systems must be transfused within 24 hours of processing, a significant limitation for use in military settings. The system to be evaluated is designed for 2 weeks post-deglycerolization storage. The second major advantage is automation of the process. Current systems require a great deal of technician manipulation and intervention. Automation of the process is expected to result in a more consistent product and permit a technician to produce red cell products for transfusion more efficiently.

During this reporting period, the BSL has performed research under one clinical trial protocol, a phlebotomy type protocol which permits collection of blood from volunteers for *in vitro* research and two *in vitro* research projects. The BACKGROUND, METHODS, RESULTS, and DISCUSSION / CONCLUSION from each research effort will be described separately in order to maximize continuity. The phlebotomy type protocol activities will be described first, followed by descriptions of the clinical trial, and the *in vitro* projects. The following section will conclude with an updated review of results from two protocols completed previously and described in detail in the preceding annual report. Data collection and initial data analysis has been completed on the first two clinical trials; the third clinical trial received full approval during the fourth fiscal quarter and is in progress. The ultimate goal of each clinical trial is to determine if the mean 24 hour post-transfusion survival of the red cells at the end of the storage period exceeds 75% in a minimum of ten volunteers. Furthermore, at least 99% of the cells collected must also remain intact on the final day of storage.

A manuscript describing the results of an *in vitro* research project completed the previously was accepted and published in the journal TRANSFUSION. An offprint copy of the journal article is at Appendix 3. The data from this research formed the basis of the clinical trial described in Section B below.

**Description of research conducted:**

**A. "Phlebotomy Procedures for Use on Human Subjects" WRAIR #514, HURRAD Log #A-6664.**

**BACKGROUND**

Aspects of red blood cell physiology critical to blood storage are species specific; therefore valid *in vitro* studies of the red blood cell storage lesion require freshly collected human blood. The quantities required range from as little as 3.0 mL to as much as a full unit, 450 mL.

**METHODS**

Volunteers are recruited from within the Detachment, other tenants of the building and the immediately surrounding community and informed fully as to the risks of donation. Potential volunteers were screened for anemia, transfusion transmitted diseases (TTD) and medical conditions which would make blood donation unsafe using the criteria of the American Association of Blood Banks<sup>14</sup> and the Food and Drug Administration 21CFR640.<sup>15</sup> The total amount of blood collected in an 8 week period is limited to 525 mL. A physician certified in Advance Cardiac Life Support was present at all full unit phlebotomies. Volunteers are compensated for their blood donations IAW 24 USC 30 and AR 40-2.

A personal computer data base is used to maintain documentation of all volunteer related transactions and assure compliance with donation volume and interval limitations. Phlebotomies were performed by trained contract staff and selected, trained active duty personnel.

**RESULTS**

During fiscal year 1998, the following blood collections were made.

Volume	WRAIR	BRD / Clinical Trial	Anthrax Immune / Pittman	Transfusion Med Rsch	AFIP / AFDIL	Total
1 - 50 mL	133	N/A	N/A	9	5	147
51 - 100 mL	18	N/A	N/A	3	2	23
101 - 200 mL	2	N/A	N/A	0	6	8
Units (>200mL)	5	25	96	56	0	182
Total Number of Phlebotomies Performed						360

The set of collections labeled "WRAIR" were performed for various investigators within the Blood Research Detachment and the "BRD/Clinical Trial" collections were made specifically in support of clinical trial protocols. The collections identified as "Anthrax Immune / Pittman" were collected in collaboration with LTC Phillip Pittman, MC, USAMRIID. The plasma from

these anthrax immunized volunteers was used in the development of an anthrax immune globulin; the red cells for these collections were used in other BRD research. The collections labeled "Transfusion Med Rsch" were performed to support research in the Transfusion Medicine Research Laboratory of the Naval Medical Research Institute which is co-located with the BRD. The remaining thirteen collections were in support of the Armed Forces DNA Identification Laboratory of the Armed Forces Institute of Pathology also co-located with the BRD.

One hundred-six new volunteers were enrolled during the fiscal year. The majority of the newly enrolled volunteers had blood collected only for the harvest of their anthrax-immune plasma. Twenty-three of the enrolled volunteers were converted to inactive status because they had left the area and were otherwise unavailable or withdrew for unstated personal reasons. Two hundred-eighty sets of transfusion transmitted disease tests were performed during the report period. Single separate reactive results for hepatitis B surface antigen, anti-hepatitis B core antibody, antibody to human T lymphotropic virus I/II and antibody to human immunodeficiency virus I/II were detected. The affected volunteers were informed of the test results and counseled by a physician.

No side effects or reactions were observed other than the 4 mild donor reactions, such as syncope and bruising at the phlebotomy site. Such events occur occasionally during blood donation and are not unusual. The staff employed the procedures specified in the protocol to deal with donor reactions; there were no sequelae.

## **DISCUSSION / CONCLUSION**

Fourteen percent of the small volume collections and 31% of the full unit collections were performed for the Transfusion Medicine Research Laboratory of the Naval Medical Research Institute and the Armed Forces Institute of Pathology co-located with the BRD. The remainder supported WRAIR and USAMRMC sponsored research.

There were no instances where the volume or donation interval limitations were exceeded. The blood collection requirements of the BRD were safely provided from a pool of healthy, screened volunteers.

**B. "Evaluation of the *in vitro* and *in vivo* Viability of Red Blood Cells Stored in Blood Storage Solutions CPDA-1 for 35 Days and in AS-5 for 42 Days at 1-6 C and Exposed for Short Periods to Higher Temperature" WRAIR #633, HURRAD Log #A-7818.**

## **ABSTRACT**

### **BACKGROUND**

No data exist on the viability of RBCs stored in modern additive solution systems and allowed to warm above 10°C.

## Study Design and Methods

In a randomized cross-over study, three units of blood were collected at least 8 weeks apart from 11 volunteer donors and stored in additive solution-5 (AS-5). One unit from each volunteer was stored 1) for 6 weeks at 4°C, 2) for 5 weeks at 4°C except for 24 hours at 25°C on day 14, and 3) for 5 weeks at 4°C except for 24 hours at 25°C on day 28. Units were sampled periodically during storage and at the end of storage viability was measured by the  $^{99m}\text{Tc}/^{51}\text{Cr}$  double label method.

## Results

RBC viability was not significantly different between storage protocols. Less than 1% of stored cells hemolysed. RBC ATP concentrations at the end of storage correlated with viability and were approximately equal in the warmed units after 30 days storage and the conventionally stored units after 42 days.

WRAIR Protocol # 633 was completed and a manuscript prepared for submission to the journal TRANSFUSION during this report period. A copy of the prepared manuscript is attached to this report as Appendix 4.

## C. "The *in vitro* storage characteristics of red blood cells stored in increasing volumes of AS-1"

### BACKGROUND

Meryman and colleagues reported prolonged maintenance of ATP concentrations, morphological index and 2,3-DPG concentrations when the red cells were stored for 14 weeks in a large volume of an experimental hypotonic additive solution.<sup>16</sup> The storage hematocrit in those experiments were less than 10%. Results from the hypotonic additive solution AS-24 we evaluated in WRAIR protocol #572, when the storage hematocrit was approximately 55%, were disappointing. To examine the remaining variable, volume of additive solution, we measured the *in vitro* storage characteristics of red cells stored in the isotonic additive solution AS-1 (ADSOL®) at a progressively lower storage hematocrit. The working hypothesis was that the increased volume of additive solution would provide a larger pool of nutrients and provide a larger pool of buffer for the acid produced during glucose metabolism; the packed red blood cells (pRBC) stored dilute would deteriorate more slowly than those stored at the higher hematocrit used in routine storage.

### METHODS

Four hundred-fifty mL of whole blood was collected into CPD from each of 16 volunteers and plasma removed after a hard centrifugation at 5000 x g for five min. One hundred mL of AS-1 was added to the pRBC and two ABO identical units were pooled into a 1 L transfer bag. The pooled pRBC were subsequently divided into three aliquots with a target volume of 327 - 375 mL. The first aliquot was created by transferring approximately 350 mL of the pooled, undiluted

red cells to a 500 mL transfer bag; the target hematocrit was 55 - 60%. To the second and third transfer bags sufficient red cells were transferred so that with the addition of AS-1, target hematocrits of  $35\% \pm 3\%$  and  $20\% \pm 3\%$  respectively were achieved in final volume of approximately 350 mL. The aliquots were sampled at day of creation and weekly thereafter for seven weeks. Data was analyzed graphically and by analysis of variance calculations. The threshold of significance was set a  $p \leq 0.05$ .

## RESULTS

Mean supernatant pH was essentially the same in all aliquots at all sampling points. Whole blood glucose levels were higher in the more dilute aliquots at all sampling points. ATP concentrations were initially higher in the more dilute aliquots than in the more concentrated cells, but by week 4 the order had reversed and the pattern remained to the end of sampling at seven weeks, see Appendix 5.

## DISCUSSION / CONCLUSION

The maintenance of higher glucose concentrations in the more dilute red cell aliquots is a reflection of the available glucose pool in the AS-1. The close similarities of pH throughout storage at all dilutions is probably a result of the excess available buffering capacity. However, the pattern of ATP concentrations is less easily explained. Given the availability of glucose at a relatively constant pH, the ATP might be expected to remain higher in the more dilute than the more concentrated aliquots. Instead, after 3 weeks of storage, the opposite occurs. AS-1 contains adenine, but no phosphate, the ATP metabolic building blocks. Perhaps the red cell and plasma metabolic pool of phosphate is depleted more quickly in the dilute aliquots resulting in more rapid depletion of ATP.

### **D: "The storage characteristics of red blood cells stored in Experiment Additive Solutions EAS-61 and EAS-64"**

## BACKGROUND

Dr. Tibor Greenwalt, Hoxworth Blood Center, Cincinnati, OH, under contract with the USAMRMC has developed a series of experimental additive solutions (EAS) for the prolonged preservation of red cells. EAS-61 has, in preliminary testing, preserved red cells in liquid storage for 8 and 9 weeks with 85% and 81% twenty-four hour post transfusion survival respectively. (Reference: Personal communication COL John Hess) The principle difference of this solution compared to other additive solutions is the inclusion of disodium phosphate which raises the pH of the storage solution and, consequently, the initial pH of the stored blood. In addition, EAS-61 is hypotonic because it contains less salt and more water; two hundred mL EAS-61 is added to the red cells from a single unit versus 100 mL for the licensed additive solutions such as AS-1, -3 or -5. EAS-64 is a variant of EAS-61 which has yet more water and sufficient added NaCl and glucose to maintain the same concentrations of those ingredients as in EAS-61.

## **METHODS**

Four hundred-fifty mL of whole blood was collected into CPD from each of 30 volunteers and plasma removed after a hard centrifugation at 5000 x g for five min. The pRBC from three ABO identical units were pooled into a 1 L transfer bag. The pooled pRBC were subsequently equally divided into three aliquots into individual 800 mL transfer bags. One hundred mL AS-5, a licensed preservative was added to the first aliquot and designated the control. Two hundred mL of EAS-61 was added to the second aliquot and three hundred mL of EAS-64 was added to the third. All ten sets of aliquots were sampled on day of creation and weekly thereafter for eleven weeks. Data is to be analyzed graphically and by analysis of variance calculations. The threshold of significance was set a  $p \leq 0.05$ .

## **RESULTS and DISCUSSION / CONCLUSION**

The study is in progress with no data available for analysis.

**E. "Evaluation of the *in vivo* Viability of Red Blood Cells Stored for Prolonged Period in the Leukotrap® RC AS-24 System" WRAIR #572, HURRAD Log #A-6986.**

And

**F. "Evaluation of the *in vivo* Viability of Red Blood Cells Stored for Eight Weeks in the Leukotrap® Whole Blood AS-3 System" WRAIR #591, HURRAD Log #A-7089.**

## **BACKGROUND**

WRAIR protocols # 572 and # 591 were performed under terms of a cooperative research and development agreement (CRDA) with the MEDSEP Division of the PALL Filter Corporation. Both protocols were completed in the previous fiscal year and described in the previous annual report. Additional information regarding these two protocols is being included in the current annual report because of additional data analysis. Protocol #572 evaluated an experimental system incorporating a new formulation of chemicals, AS-24, already used in FDA approved solutions for blood storage, and an integral white blood cell removal filter. The object was to determine if this unique preservative formulation coupled with prestorage white cell removal would permit storage for eight weeks. Protocol #591 was designed to evaluate a second experimental system for potential eight week red cell storage. The blood collection system utilized in protocol # 591 differed from the system employed in protocol # 572 in two aspects. First, the FDA licensed AS-3 replaced the experimental hypotonic AS-24 preservative solution in the test units. Second, the system was reconfigured to accomplish white cell removal during collection of the whole blood rather than after the preparation of the packed cells as was the case in protocol #572.

## **Results**

Further analysis of the 24 hour post-transfusion red cell survival data from the two protocols, #572 and #591, reveals the following. The post transfusion survival of AS-3 red cells

stored for 6 weeks without leukoreduction was nearly identical in both protocols,  $77\pm 3\%$  and  $77\pm 2\%$  in #572 and #591 respectively. There was no significant difference in the survival of red cells in the test units,  $64\pm 3\%$  for the AS-24 leukoreduced units stored for 8 weeks in protocol #572 and  $67\pm 2\%$  for the AS-3 leukoreduced units stored for 8 weeks in protocol #591. A graphic comparison of the red cell survival data from both protocols is included as Appendix 6.

### **Discussion/Conclusion**

The experimental hypotonic red cell storage system AS-24 preserved red cells no better at 8 weeks of storage than the isotonic storage system AS-3 when cells are stored for the same period. Leukoreduction alone does not improve red cell preservation sufficiently to permit two additional weeks of storage.

### **GENERAL AND ADMINISTRATIVE**

There have been no significant administrative changes in contract operation since the previous the previous annual report. Instead, existing systems and processes for documentation, equipment maintenance and repair, and laboratory testing procedure validation have been maintained to meet research requirements.

Manuscripts of research results from contract supported research has been submitted for publication with some published during the report period. The status of each manuscript submission is detailed in previous sections of this report.

A significant amount of planning has gone into preparation for relocation to the new WRAIR facility, Building 503 on the Forest Glen Campus of Walter Reed. The move is scheduled for 20 March 1999. The laboratory staff has visited the new facility and laboratory mock up, and assessed equipment needs for the new facility. Because of space limitations in the new facility and the reduced need for redundancy of critical equipment, excess equipment has been designated for turn-in. The plan is to suspend all laboratory operations in the current location at the end of February 1999.

### **SUMMARY**

The contract staff has supported the BRD by operating and maintaining the Blood Storage Laboratory to support both existing and new requirements. Staff are trained and systems are in place which supported specific red cell survival protocols. The BRD mission has been supported.

## REFERENCES

1. Chapman KW, Snell SM, Jesse RG, Morano JK, Everse J, and Winslow RM. Pilot Scale Production of Pyrogen-Free Human Hemoglobin for Research, *Biomat., Art. Cells & Immob. Biotech.* 1992; 20(2-4):415-421.
2. Nelson D, et.al. Preparation and Characterization of Diaspirin Cross-Linked Hemoglobin Solutions for Preclinical Studies, *Biomat., Art. Cells & Immob. Biotech.* 1992; 20(2-4):423-427.
3. Winslow RM and Chapman KW. Pilot-Scale Preparation of Hemoglobin Solutions, *Methods in Enzymology.* 1994; 231:3-16.
4. Farmer M, Ebeling A, Marshall T, Hauck W, Sun CS, White E, Long Z. Validation of Virus Inactivation by Heat Treatment in the Manufacture of Diaspirin Cross linked Hemoglobin, *Biomat., Art. Cells & Immob. Biotech.* 1992; 20(2-4):429-433.
5. Cliff RO, Ligler F, Goins B, Hoffmann PM, Speilberg H, Rudolph AS. Liposome Encapsulated Hemoglobin: Long-Term Storage Stability and In Vivo Characterization, *Biomat., Art. Cells & Immob. Biotech.* 1992; 20(2-4):619-626.
6. Rudolph AS. Encapsulation of Hemoglobin in Liposomes, *Blood Substitutes: Physiological Basis of Efficacy*, 1995; 7:90-104.
7. Meryman HT, Hornblower M, Syring RL. Prolonged Storage of Red Cells at 4°C. *Transfusion.* 1986; 26:500-505.

8. Meryman HT, Hornblower M, Syring RL, Mesbah-Karimi N. Extending the Storage of Red Cells at 4°C. *Transfusion Science*. 1994; 15:105-115.
9. Greenwalt TJ, McGuinness CG, Dumaswala UJ, Carter HW. Studies in Red Blood Cell Preservation 3. A Phosphate-Ammonium-Adenine Additive Solution. *Vox Sanguinis*. 1990; 58:94-99.
10. Dumaswala UJ, Oreskovic RT, Petrosky TL, Greenwalt TJ. Studies in Red Cell Preservation 5. Determining the Limiting Concentrations of  $\text{NH}_4\text{Cl}$  and  $\text{Na}_2\text{PO}_4$  Needed to Maintain Red Blood Cell ATP During Storage. *Vox Sanguinis*. 1992; 62:136-140.
11. Greenwalt TJ. Personal Communication, August 1997
12. Greenwalt TJ. Personal Communication, August 1998
13. Surgeoner D, Klein H, Institute of Medicine Conference on Blood Safety and Availability, 9 June 1995, Washington, DC.
14. Donor Selection and Blood Collection. In Vengelen-Tyler V, Ed. Technical Manual, 12th Edition, American Association of Blood Banks, Bethesda, MD, 1996:73-102.
15. Code of Federal Regulations, Title 21 Section 640, U.S. Government Printing Office

16. Meryman HT, Hornblower M, Syring R, Mesbah-Karimi N. Extending the cells at 4°C.

Transfus Sci, 1994, 15:2;105-115.

17. Hess J. Personal Communication, 1998.

## Appendix 1

Contract Employees as of end of Fiscal Year 1998:

Lloyd E. Lippert, Project Manager (Full-time)

Claudia Derse-Anthony, Technologist (Full-time)

Cynthia Oliver, Technologist (Full-time)

Betty Dismukes, Administrative Assistant (Part-time)

Nicole Putnam-Frenchik, Administrative Assistant (Part-time)

# An Improved Process for the Production of Sterile Modified Haemoglobin Solutions



Frank A. Highsmith,<sup>1</sup> Christine M. Driscoll,<sup>1</sup> Brian C. Chung,<sup>1</sup> Mark D. Chavez,<sup>2</sup>  
Victor W. Macdonald,<sup>2</sup> James M. Manning,<sup>3</sup> Lloyd E. Lippert,<sup>1</sup> Robert L. Berger<sup>2</sup>  
and John R. Hess<sup>2\*</sup>

<sup>1</sup>The Bionetics Corporation, Rockville, MD, <sup>2</sup>The Blood Research Detachment of the Walter Reed Army Institute of Research, Washington, DC, and <sup>3</sup>The Rockefeller University, New York, NY

**Abstract.** The process for manufacturing bulk quantities of sterile solutions of human haemoglobin (Hb) cross-linked between the alpha chains ( $\alpha\alpha$ Hb) with bis(3,5-dibromosalicyl) fumarate (DBBF) was modified to: (1) improve product purity; (2) increase product yield; (3) eliminate non-United States Pharmacopoeia materials; (4) reduce reagent costs; and (5) reduce production time. These process modifications were the result of increased scientific understanding of the Hb cross-linking chemistry and were in the form of engineering and procedure controls that reflect current good manufacturing practices (cGMP). Purity, as reflected in the fractional yield of the desired  $\alpha\alpha$ Hb product, has increased from 60% to 90+% of total Hb, and uncross-linked Hb was virtually eliminated. Impurities such as pyrogens, methaemoglobin, phospholipid, and free iron were reduced. The net yield of  $\alpha\alpha$ Hb was increased from 33% to 58% of starting Hb content. Production time, the use of overtime, the consumption of expensive reagents and filters, and losses because of contamination have all been reduced. As a result, cost per gram of  $\alpha\alpha$ Hb produced has decreased 60%. With this improved process, efficient production of very pure  $\alpha\alpha$ Hb is possible.

### Introduction

The U.S. Army produces kilogram quantities of modified haemoglobin from outdated human red blood cells to support research in the development of red blood cell substitutes. The Army seeks a blood substitute to serve as a universal oxygen-carrying resuscitation fluid on the battlefield. Haemoglobin, with its high oxygen carrying capacity, moderate colloid osmotic activity, and low antigenicity, is the most likely candidate blood substitute material.<sup>1</sup> Volumes greater than 100 litres per year of sterile 10 g/dl haemoglobin solutions are required to support this ongoing research and development process. The total volume is large because the safety and efficacy testing of resuscitation fluids require the infusion of substantial volumes of the material. Further, the manufacture of a major derivative

product, a liposome-encapsulated haemoglobin, is only 15% efficient and requires large volumes of starting material.<sup>2</sup> Additional volumes of the haemoglobin are used for research into several types of brain injury and for basic studies of haemoglobin function and modification.<sup>3,4</sup>

The Army's original haemoglobin production facility was built at the Letterman Army Institute of Research (LAIR) on the Presidio of San Francisco in 1990. Descriptions of the original process and product have been published.<sup>5</sup> In 1993, with the closure of the Letterman Institute, the facility was moved to the Walter Reed Army Institute of Research (WRAIR) and re-established. The facility was rebuilt by a civilian engineering firm, brought to operation by Army personnel, and then turned over to an industrial operating company for continued operation and maintenance.

To understand the rationale for the process of haemoglobin recovery, modification, and purification, a brief discussion of the biochemistry and physiology of haemoglobin is necessary. Haemo-

\*To whom correspondence should be addressed:  
Col. John R. Hess, M.D., Walter Reed Army Institute  
of Research, Blood Research Detachment, Washington  
DC 20307-5100.

globin is the primary oxygen carrier in all higher animals. Normally, it is present in red blood cells, which provide the environment necessary for its proper function and protect the haemoglobin from degradation. Haemoglobin is a classic allosteric protein in that a ligand or effector molecule binding at one site on the haemoglobin can change the binding of ligands at other sites.<sup>6</sup> When the haemoglobin molecule binds oxygen, it changes conformation. Low affinity deoxyhaemoglobin, with four potential oxygen binding sites, turns into higher affinity partially liganded oxyhaemoglobin. In this way, oxygen affinity increases with each subsequent oxygen molecule bound, an effect called co-operativity. This co-operativity is delicately balanced to allow blood to saturate with oxygen in the lung and yet unload the oxygen as oxygen partial pressures decline in the tissues. Co-operativity is usually visualized as the sigmoid curve that relates oxygen partial pressure to the fractional saturation of haemoglobin. It is often expressed as a logarithmic function of the slope of the curve (the Hill number) at the point where the haemoglobin is 50% saturated (the  $P_{50}$ ).<sup>7</sup>

In the red blood cell, haemoglobin oxygen affinity is regulated by  $H^+$ ,  $CO_2$ ,  $Cl^-$ , and 2,3-diphosphoglycerate (2,3-DPG). 2,3-DPG is the most important of these effectors in normal cells, stabilizing the deoxy-form and reducing the oxygen affinity. When haemoglobin is removed from red blood cells, most of the 2,3-DPG and  $CO_2$  disperse. Without these effectors, the oxygen affinity rises as seen in the decrease in the  $P_{50}$  from 27 Torr to 10 Torr. Cooling further increases the affinity of haemoglobin stripped of effectors from a  $P_{50}$  of 10 Torr at 37°C to 4 Torr at 5°C.<sup>8</sup> The unloading of oxygen then becomes difficult because of the small partial pressure gradient available to drive it away.

Structurally, native haemoglobin is a tetramer composed of two alpha globin and two beta globin chains ( $\alpha\alpha\beta\beta$ ). Each individual globin protein chain is folded to surround an iron-containing haem group where oxygen is bound and released. The folding of the monomers and their assembly into a tetramer are all controlled by non-covalent interactions. These interactions are weakest between the like globin chains, so haemoglobin tetramer is in rapid equilibrium with the low concentrations of heterodimer [ $\alpha\beta$ ]<sup>9,10</sup> [Fig. 1(a)]. Within the red blood cell, heterodimers are retained and rapidly reassociate back to tetramer. Outside the red blood cell, the free

heterodimer is not desirable because it is filtered and accumulated by the kidney, causing renal damage. Even the unmodified tetramer is also not desirable in the circulation because it dissociates into heterodimers and because unmodified tetramer binds oxygen more avidly and less co-operatively than normal blood.

In manufacturing a haemoglobin-based blood substitute, the problems of tetramer-dimer equilibrium and high oxygen affinity are addressed by modifying the haemoglobin tetramer. The haemoglobin modification used in this process, cross-linking the  $\alpha$ -globin chains from one  $\alpha$ -lysine-99 to the other with fumarate,<sup>11</sup> prevents the formation of the dimer and subsequent renal damage [Fig. 1(b)]. In addition, cross-linking between the  $\alpha$ -lysine-99s makes the binding and release of oxygen by the cross-linked tetramer ( $\alpha\alpha Hb$ ) much like that of normal blood.

Another concern of manufacturing is maintaining the integrity of the product. Despite the relative stability of haemoglobin, heat, shear, and oxidative stress can all damage the molecule. Oxidation of  $Fe^{2+}$  haemoglobin to  $Fe^{3+}$  methaemoglobin is the usual first step in the degradation of oxygenated solutions at room or body temperatures. Inside the red blood cell haemoglobin oxidation is quickly reversed by the methaemoglobin reductase enzyme system. Outside the red blood cell the conversion to methaemoglobin proceeds unchecked. The molecule can further degrade with the loss of haem and iron and the unraveling of the protein to form linear strands that aggregate and precipitate. The haemoglobin breakdown products, haem and iron, can potentiate oxygen free radical reactions and lead to further protein damage.<sup>12</sup>

With the structural and functional characteristics of haemoglobin in mind, the facility and procedures developed at LAIR were modified to increase the yield and purity of the product and the efficiency and reproducibility of the process. This paper describes the new production process, the improvements in the quality of the product, and reviews the critical changes. This information is presented as a model for the large scale production of modified haemoglobin.

### The new modified haemoglobin production process

#### Process overview

The production of a 20-litre sterile batch of  $\alpha\alpha Hb$  solution requires 30 working hours over a five-day

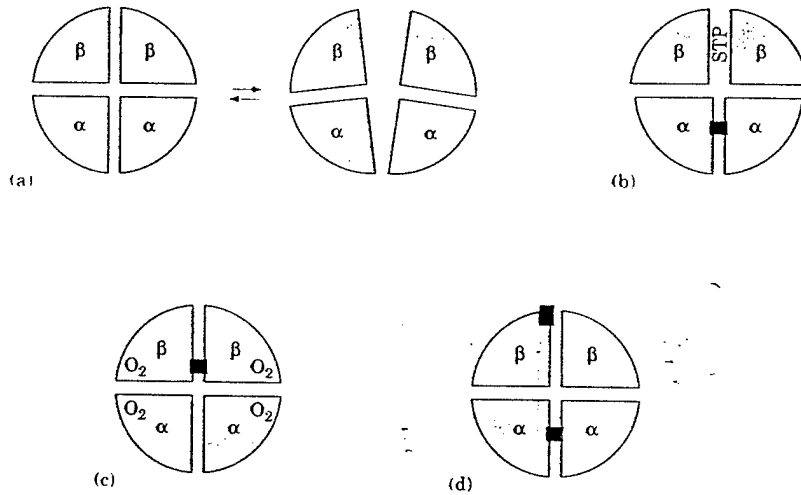

Figure 1. Schematic of Haemoglobin and its modification. (a) Haemoglobin is a tetrameric globular protein composed of two alpha ( $\alpha$ ) and two beta ( $\beta$ ) chains. The chains are not covalently held together. At high concentrations, the tetramer dominates while at low concentrations the heterodimer is favoured. (b) There are two sites where the compound bis(3,5-dibromosalicyl) fumarate (DBBF) can covalently cross-link (shown as ■),  $\beta$ -lysine-82 to  $\beta$ -lysine-82 and  $\alpha$ -lysine-99 to  $\alpha$ -lysine-99. Deoxygenated haemoglobin favours cross linking between the two  $\alpha$ -lysine-99s. In addition, the  $\beta$ -lysine-82 sites can be blocked with sodium tripolyphosphate (STP), optimizing the desired product  $\alpha\alpha$ -cross-linked haemoglobin. (c) Oxygenated haemoglobin will primarily cross link between the two  $\beta$ -lysine-82s, forming  $\beta\beta$ -cross-linked haemoglobin. (d) Extra DBBF can react with other lysine sites such as a univalent linkage to the  $\beta$ -chain terminal amino group ( $\beta$ -NH<sub>2</sub>).

period. All processes are conducted at 5°C unless otherwise specified. On the first day, 80 units of outdated human red blood cells (RBCs) are pooled into a sterile vessel. On the second day, the RBCs are washed by cross-flow filtration with an isotonic saline solution and lysed with a hypotonic phosphate solution. The resulting haemolysate solution, which starts with 97.5% of its protein content as haemoglobin, is purified by filtration through 0.1  $\mu$ m and 500 kDa filters, eliminating the stromal material. Haemoglobin is then concentrated with a 5 kDa filter, removing low molecular weight impurities with the permeate. Sodium tripolyphosphate (STP) is added to the haemoglobin to increase the buffering capacity of the solution and to block competing cross-linking sites at the  $\beta$ -lysine-82s and  $\beta$ -NH<sub>2</sub> in the  $\beta_1\beta_2$  cleft [Figs 1(c) and 1(d)]. The solution is then transferred to a bioreactor. On the third day, the stroma-free haemoglobin solution in the STP "blocking" buffer is warmed to 25°C, the solution is deoxygenated, and the haemoglobin is cross-linked with bis(3,5-dibromosalicyl) fumarate (DBBF). The cross-linked haemo-

globin solution is then heat treated at 76°C and pH 6.9 for 90 min to denature selectively unmodified haemoglobin and inactivate some potential viral contaminants. On the fourth day, the contents of the bioreactor, including about 750 g of denatured protein, are filtered, oxygenated, refiltered through the 0.1  $\mu$ m and 500 kDa filters, and formulated in the final physiological buffer by cross-flow diafiltration using the 5 kDa filter. On the morning of the fifth day, the resulting solution is sterile packaged and frozen at -80°C. More than 70 standard operating procedures (SOPs) support facility operations by detailing facility cleaning, buffer preparation, in-process analysis, and other quality control procedures.

#### First day procedures

On the first day of the production process (Fig. 2), 80 units of outdated human red blood cells, not more than 63 days from the date of donation, are pooled. Pooling is accomplished by transfer from the original bags into a 30-litre sterile tank T0 (Alloy Products Corp., Waukesha, WI) via

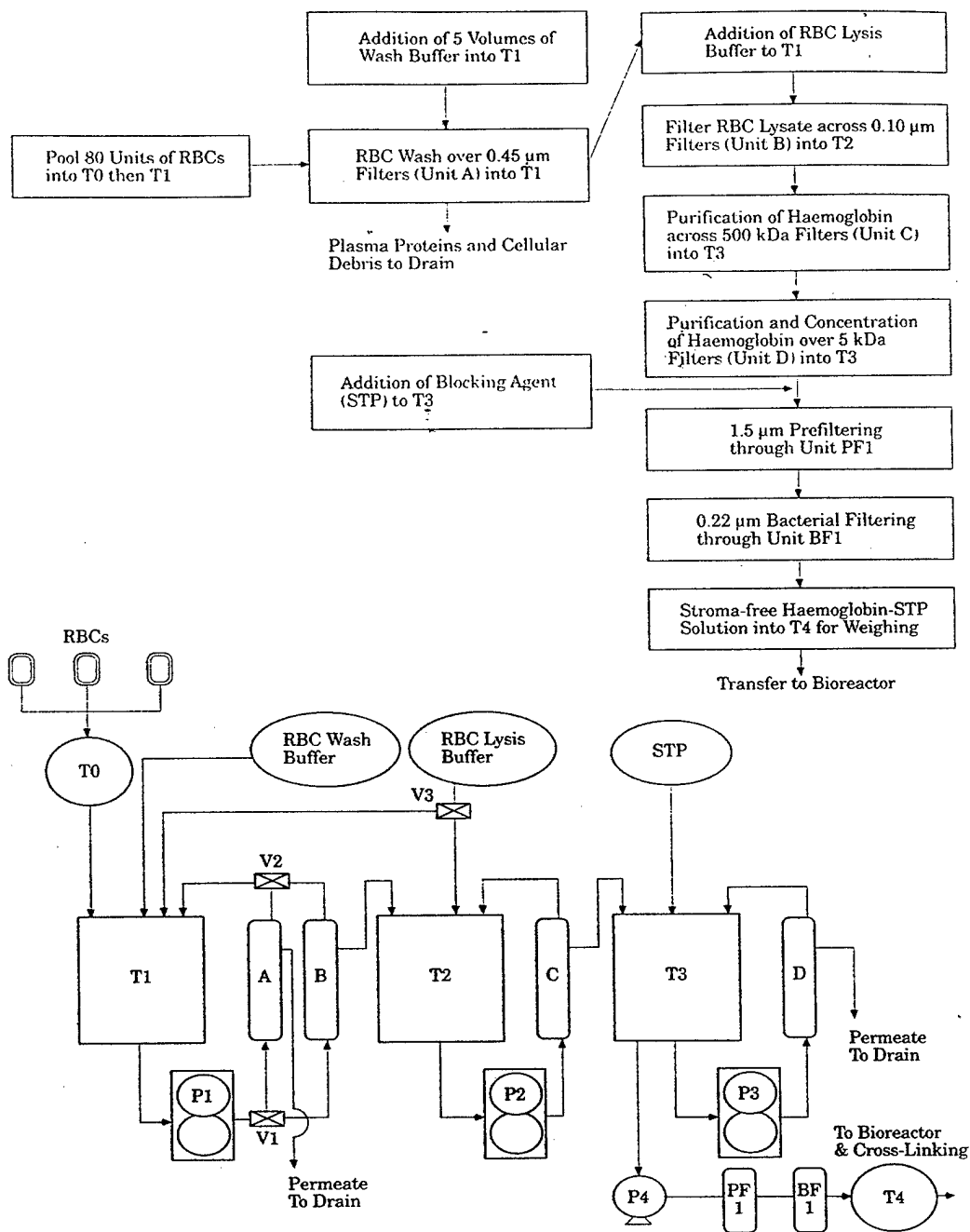

Figure 2. Process and flow diagrams for days 1 & 2. Red blood cells are pooled, washed, and lysed. Cell fragments are removed by stepwise filtration, generating stroma-free haemoglobin solution.

clinical blood administration sets with 170–260  $\mu\text{m}$  nylon aggregate filters (IC8087, Baxter Healthcare Corp., IV Division, Deerfield, IL). Experience has

shown that clinically incompatible blood types can be mixed and stored overnight at 5°C without lysis.

### *Second day procedures*

On the second day (Fig. 2), 20 litres of 0.9% W/V sodium chloride (isotonic saline) is added to the 100-litre tank T1 (DCI Inc., St Cloud, MN) to prime the 0.45  $\mu\text{m}$  filter bank A (CFP4-E-55 SMO, A/G Technology Corp., Needham, MA). The priming volume is circulated by pump P1 (Model 60, Waukesha Fluid Handling, Waukesha, WI) in the closed circuit consisting of valve V1, 0.45  $\mu\text{m}$  filter bank A, valve V2 and tank T1. The pooled cells (~20 litres) are then added to the 20-litre priming volume in T1. The cells are washed with isotonic saline, and the plasma proteins are removed with the permeate of filter bank A. A constant volume of 40 litres is maintained with the addition of isotonic saline into T1. Washing of the red blood cells is complete when no albumin is spectrophotometrically detected at a wavelength of 280 nm in the permeate of filter bank A. Two-hundred litres of isotonic saline is sufficient to accomplish the RBC washing.

Washed cells are then lysed by adding hypotonic 10 mM phosphate buffer at pH 7.60 (lysis buffer) through valve V3 into tank T1 while maintaining the constant 40-litre volume. Valves V1 and V2 are then switched to bypass filter bank A, and the lysed cells are pumped with pump P1 through valve V1, the 0.1  $\mu\text{m}$  filter bank B (CFP-1-E-55SMO, A/G Technology Corp., Needham, MA), valve V2, and back into tank T1. The haemoglobin contained in the permeate from filter B flows into the 100-litre tank T2 (DCI Inc., St Cloud, MN) while the retentate containing the RBC membranes flows back to tank T1. Lysing continues until  $\leq 0.5$  g/dl haemoglobin is detected<sup>13</sup> in tank T1. Upon completion of lysing, valve V3 is switched and lysis buffer is added directly to tank T2 to sustain a minimum circulation volume. Purification of the haemoglobin continues by circulation through pump P2 (Model 30, Waukesha Fluid Handling, Waukesha, WI) through the 500 kDa filter bank C (UFP-500-E-55SMO, A/G Technology Corp., Needham, MA) and back into tank T2. The haemoglobin contained in the permeate from filter bank C flows into the 40-litre tank T3 (DCI Inc., St Cloud, MN) and the retentate containing high molecular weight (>500 kDa) impurities returns to tank T2. Further purification and concentration occur by pumping the solution in tank T3 with pump P3 (Model 60, Waukesha Fluid Handling, Waukesha, WI) through the 5 kDa filter bank D (UFP-5-E-55SMO, A/G Technology Corp., Needham, MA) and back into tank T3. Molecules <5 kDa (salts, buffers, water, etc.) are discarded in

the permeate of filter bank D and the haemoglobin is retained in tank T3.

The solution is concentrated to 10 g/dl of haemoglobin and weighed in T3. A solution of 20 mM STP at pH 6.50 is added to the haemoglobin in tank T3 in sufficient volume to produce an 8:1 molar ratio of STP to haemoglobin. The resulting solution is pumped with pump P4 through a 1.5  $\mu\text{m}$  prefilter PF1 (ZCPP1-1.5C, Domnick Hunter, Inc., Charlotte, NC) and 0.2  $\mu\text{m}$  bacterial filter BF1 (ZCMA1-020C-P, Domnick Hunter, Inc., Charlotte, NC) into weighing tank T4 (Alloy Products Corp., Waukesha, WI). Finally, the solution is weighed, transferred to the bioreactor, cooled to 5°C, and stirred at 200 rpm overnight.

### *Third day procedures*

Day three of the production process (Fig. 3) begins by warming the haemoglobin solution in the bioreactor BR (LSL Biolafitte, France) to 25°C to facilitate rapid deoxygenation.<sup>8</sup> The headspace of BR is purged with nitrogen and the solution is deoxygenated by pumping it with pump P4 (701S, Watson-Marlow, Concord, MA) through two membrane oxygenators MO1 & MO2 (Univox, Baxter Healthcare Corp., Bentley Division, Irvine, CA) connected in series and back into the BR. Nitrogen gas flows countercurrent to the haemoglobin through MO1 and MO2 (gas to solvent flow rate of 1:1) at 7 litres per min. Oxygen removal is monitored spectrophotometrically (Model 8452A, Hewlett Packard, Palo Alto, CA) at 758 nm by means of the optical flow cell FC (Custom Sensors & Technology, St Louis, MO). When the spectrophotometer indicates that >95% of the oxygen bound to the haemoglobin has been removed, deoxygenation is discontinued. The haemoglobin solution is then heated to 37°C. The cross-linking reagent, DBBF, is added to the haemoglobin in 1.9:1 molar ratio as a slurry of the dry powder in 2 litres of pyrogen free water. The cross-linking reaction is allowed to proceed for 3 h. Immediately following cross-linking, the pH is adjusted to 6.90 with 5 M NaOH and the solution is warmed to 76°C to inactivate viruses and selectively denature unmodified haemoglobin. After 90 min, the solution is cooled to 5°C and stored overnight under nitrogen.

### *Fourth day procedures*

On the fourth day (Fig. 4), the contents of the bioreactor, including at least half a kilogram of suspended denatured haemoglobin and precipitated

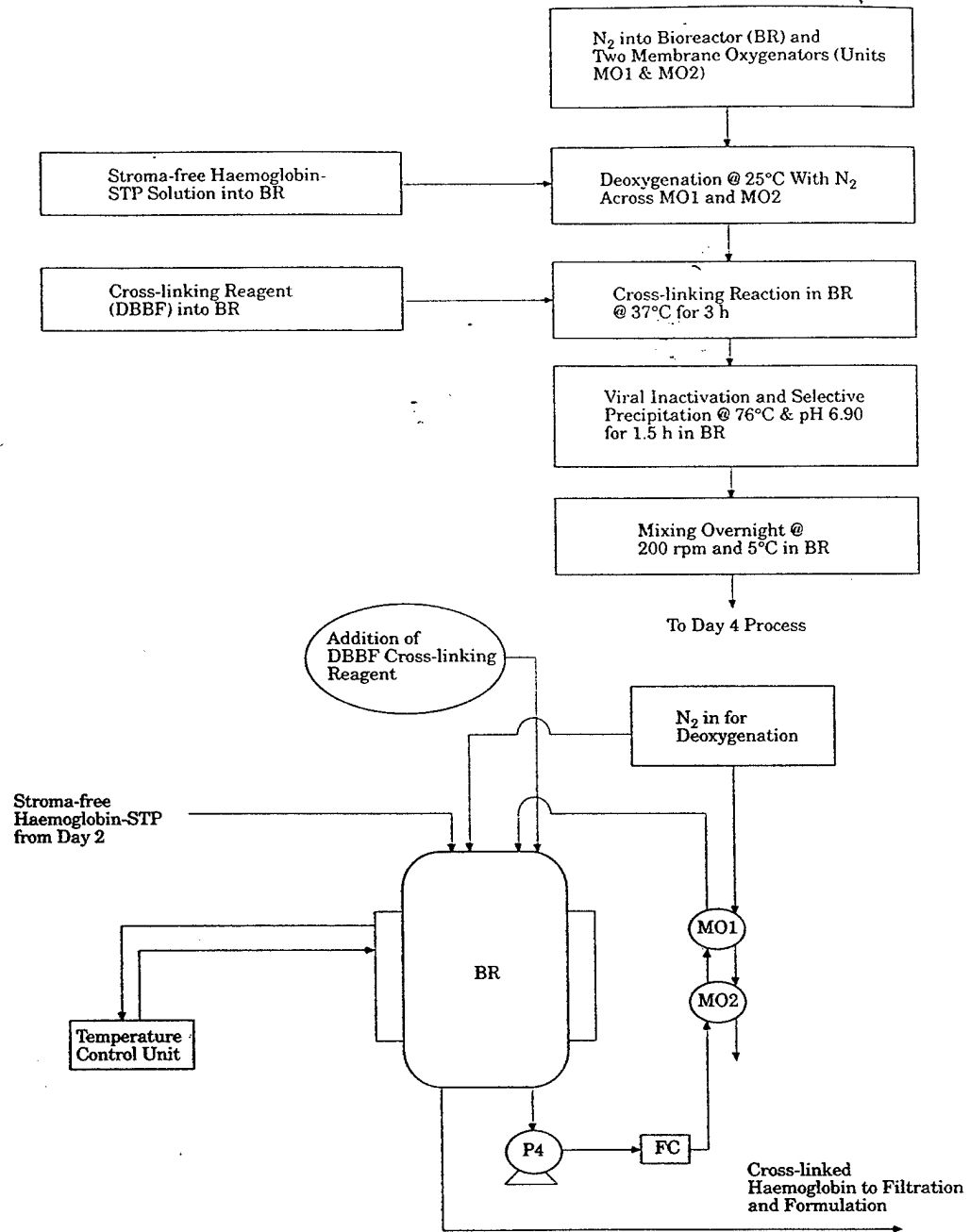

Figure 3. Process and flow diagrams for day 3. Stroma-free haemoglobin is cross-linked with DBBF, yielding  $\alpha\text{zHb}$ . Heat treatment accomplishes both pasteurization and purification of the cross-linked product.

haemoglobin sludge, are filtered through a 70  $\mu\text{m}$  prefilter PF2 (RM3F700H21, Pall Corp., East Hills, NY), a 10 to 3  $\mu\text{m}$  depth filter DF (5580502W3,

Sartorius Corp., Bohemia, NY), and collected in transfer tank T5 (Alloy Products Corp., Waukesha, WI). Haemoglobin from the holdup volumes of

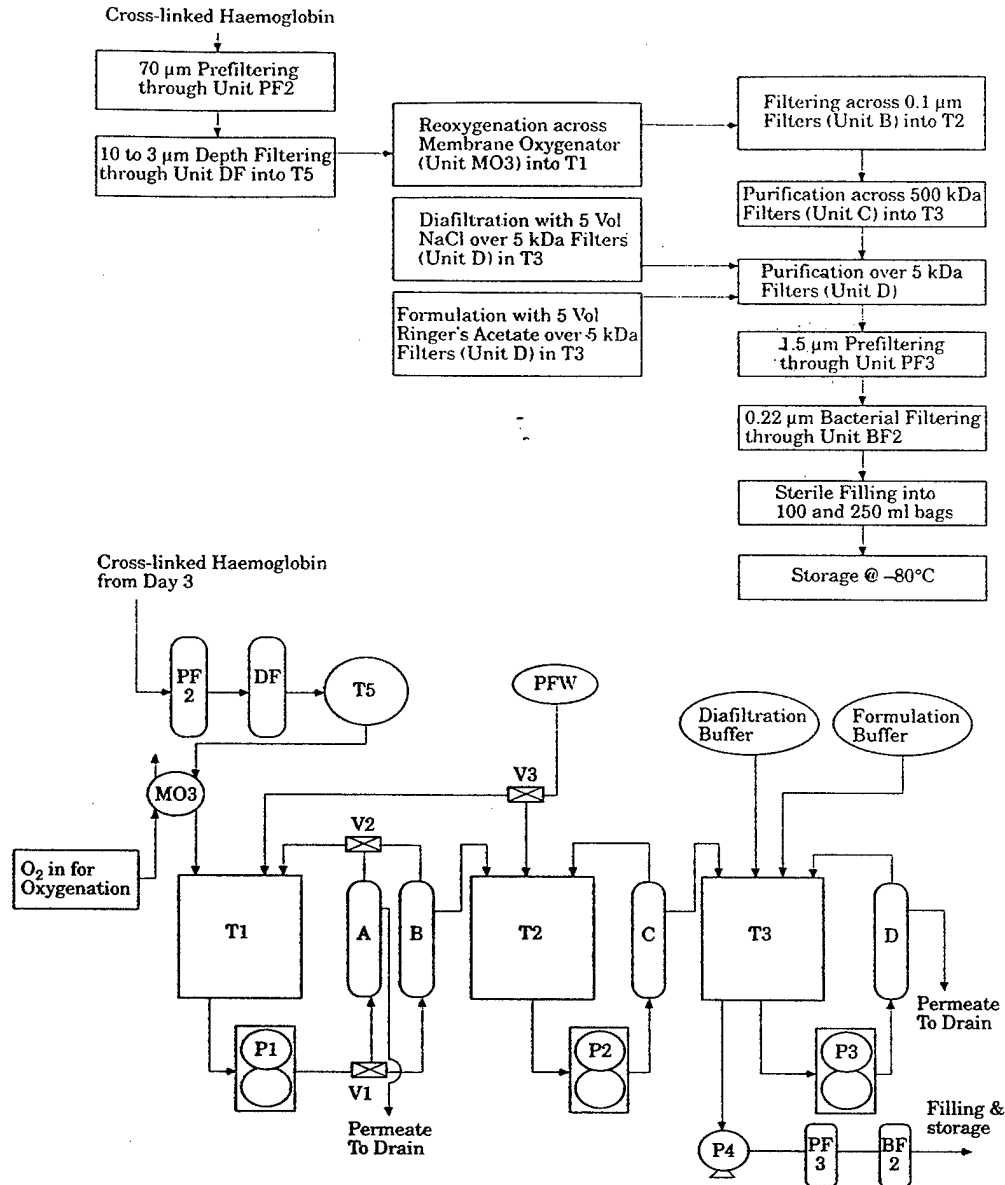

Figure 4. Process and flow diagrams for day 4.  $\alpha\alpha\text{Hb}$  is filtered stepwise through the cross flow filtration system, removing particulate matter and producing the final  $\alpha\alpha\text{Hb}$  product.

the filters is recovered by rinsing with 60 litres of isotonic saline. The haemoglobin solution is reoxygenated by pumping countercurrent to oxygen flow through membrane oxygenator MO3 (Univox, Baxter Healthcare Corp., Bentley Division, Irvine, CA) and into tank T1. Purification is accomplished by repeating the cross-flow filtration from day two in the cascading pumped loops formed by tank T1 and

filter bank B, tank T2 and filter bank C, and tank T3 and filter bank D. Twenty litres of pyrogen-free water is added to each of tanks T1 & T2 at the end of their respective portions of the filtration to maximize haemoglobin recovery from the holdup volume. Phosphate and other low molecular weight solutes are removed in the permeate of filter bank D with 200 litres of isotonic saline added to tank T3.

Final formulation is accomplished by concentrating the solution over filter bank D to 10 g/dl followed by cross-flow diafiltration with 140 litres of Ringers' acetate. The permeate from filter bank D of both buffers is discarded. The cross linked haemoglobin is then pumped with pump P4 through a 1.5  $\mu$ m prefilter PF3 (ZCPP1-1.5C, Domnick Hunter, Inc., Charlotte, NC), a 0.2  $\mu$ m bacterial filter BF2 (ZCMA1-020C-P, Domnick Hunter, Inc., Charlotte, NC), and collected into a storage vessel where it is stored overnight at 5°C.

#### Fifth day procedures

On the fifth day, the haemoglobin is packaged. The storage vessel is brought from the refrigerator to a biological safety cabinet and connected to a sterile bag filling system composed of tubing and bags, a variable-flow peristaltic pump, a digital scale, haemostats, bag seals, and crimpers. The  $\alpha$ Hb is pumped into sterile, nonpyrogenic biological storage bags (RCM-93A-4-MLL, Stericon Inc., Broadview, IL) in 100 ml and 250 ml quantities, sealed, and labelled. The  $\alpha$ Hb bags are placed in bubble-wrap envelopes, boxed, and frozen at -80°C.

#### Quality control and management

A Haemoglobin Production Committee, the authors, directed the changes in the production process and agreed to use current good manufacturing practice (cGMP) as their goal. More than 70 standard operating procedures (SOPs) were written including eight defining requirements for and the handling of source blood and other raw materials, 19 describing equipment operation and maintenance, 14 detailing production procedures, seven describing cleaning procedures, eight specifying documentation and product inventory management and 21 detailing quality control laboratory procedures. Process control analytical chemistry and final analysis for batch release were done in a dedicated laboratory. Oxygen equilibrium curves, anion exchange chromatography, and rabbit pyrogen testing were performed in separate laboratories.

#### Results

The new process for producing modified haemoglobin yields four kinds of benefits. First, the total yields of modified haemoglobin produced in each production run has increased. Second, the specificity of the process to produce the desired product,

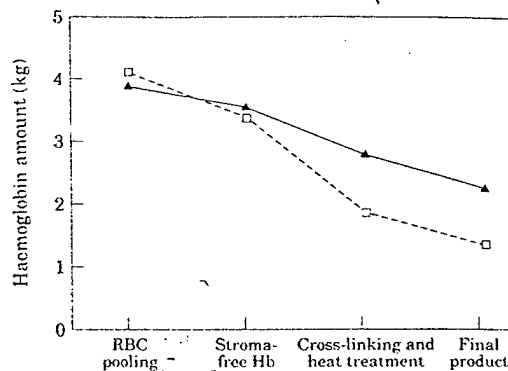

Figure 5. Haemoglobin production yields. Overall product yield has increased from 33% to 58%. Total haemoglobin amounts are measured after RBC pooling on day two at T0 (Fig. 2), on day two at T4 (Fig. 2) for stroma-free haemoglobin, on day four at T1 (Fig. 4) after cross-linking and heat treatment, and on day five at final filling and storage. (□), Letterman '91-92; (▲), Walter Reed '96.

human haemoglobin cross-linked correctly but not otherwise modified, has increased. Third, contaminants are reduced. Fourth, the cost of the process in regards to the value of materials added and the labour required has decreased.

Figure 5 shows the mass of haemoglobin at several points in the modified haemoglobin production process as performed at the Letterman Army Institute of Research (LAIR) in 1991-1992 and at the Walter Reed Army Institute of Research (WRAIR) in 1996. Yield as a fraction of the initial mass of haemoglobin has increased from 33 to 58%.

Figures 6(a) and 6(b) are anion-exchange fast performance liquid chromatograms of haemoglobin produced before and after the process changes. The dominant peak eluting at 4 min is the desired product, human haemoglobin cross-linked with fumarate between the  $\alpha$ -lysine-99s but not otherwise modified. In Figure 6(a), the peak eluting at 3 min is uncross-linked haemoglobin. The peaks to the right of the dominant peak in both figures are haemoglobin cross-linked between the  $\alpha$ -lysine-99s and further modified product with additional fumarate residues at the  $\beta$ -chain terminal amino group ( $\beta$ -NH<sub>2</sub>),  $\beta$ -lysine-82, or cross-linking  $\beta$ -NH<sub>2</sub> and  $\beta$ -lysine-82 in the same  $\beta$ -chain. As can be seen, uncross-linked haemoglobin has been essentially eliminated and the proportion of the desired product has been increased from 50 to 90+%.

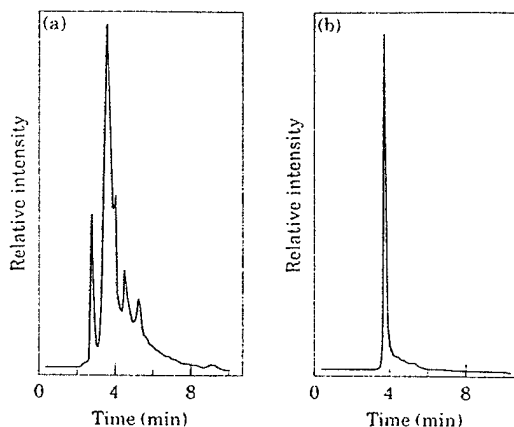

Figure 6. FPLC data on lot #950207 (prior to changes) and lot #960416. Analysis was carried out on a Pharmacia FPLC system using a mono Q HR 5/5 column at a flow rate of 1.0 ml/min. The absorbance of the eluent was measured at 405 nm with the Pharmacia on-line mercury lamp detection system with a 5 mm optical flow cell. The system was equilibrated with buffer A consisting of 20 mM Tris acetate at pH 8.3. The sample was loaded in a 100- $\mu$ l volume and eluted with a gradient of 0–20% buffer B (20 mM Tris acetate, 1.0 M NaCl) over 20 min (or 1%/min). The major fraction,  $\alpha\alpha$ Hb, elutes at 4 min.

Contamination of human-derived haemoglobin solutions can arise from the source blood, from materials purposely added in the haemoglobin purification and modification process, from microbiological growth, from materials leached from the walls of production vessels, and from the breakdown products of haemoglobin itself. Table 1 shows,

that in comparing the old and new processes, the concentrations of organic phosphate from red blood cell membrane phospholipids, free iron from haemoglobin breakdown and tank walls, bacterial endotoxin and other pyrogens, and methaemoglobin are all either lower or remain acceptably low.

The cost of the process has also been reduced. Table 1 shows the savings in the use of pyrogen-free water. The elimination of HEPES buffer from the cross-linking step saves \$3000 in each production run. Implementation of engineering changes to allow fully in-place cleaning and sterilization of filters also saves about \$3000 per run. Reduced and restructured process time has eliminated the requirement for production crew overtime, which saves an additional several thousand dollars in each production run. The improvement in run yield and reduced loss of production runs because of pyrogens results in a 125% increase in useful product per run. This yield increase and the reduced costs mean that the cost per useful gram of modified haemoglobin produced is reduced by more than 60%.

#### Discussion

The goals of improving the modified haemoglobin production process were to increase purity and yield of the product and the efficiency and reproducibility of the process. These goals were translated into specific objectives that included: (1) reducing endotoxin and pyrogen contamination; (2) eliminating non-United States Pharmacopoeia (U.S.P.) materials; (3) reducing methaemoglobin

Table 1. Comparison of batches of cross-linked haemoglobin solution

Parameter (Units)	Old Process <sup>a</sup>	New Process
Haemoglobin (g/dl)	9.8	9.95
Methaemoglobin (%)	7.5	3.20
Total Yield (%)	33	58
pH	7.56	7.39
Sterility	Pass	Pass
Rabbit Pyrogen Test (% pass)	62.5	100
Total Phosphate ( $\mu$ g/ml)	<1	0.75
Free Iron ( $\mu$ g/ml)	4.2	4.57
Pyrogen free water used (litres)	1897	1197
Total labour (h)	180	132

Comparative analytical results obtained for haemoglobin production runs acquired at Letterman Army Institute of Research (old process) and at Walter Reed Army Institute of Research (new process). Data for old process is taken from either reference 5 or is the average value from at least three production runs. Data for the new process is the average of four production runs.

formation; (4) reducing the amount of uncross-linked haemoglobin formed; (5) reducing the formation of  $\alpha\alpha$ -cross-linked haemoglobin that was then further modified; (6) minimizing the in-process denaturation of haemoglobin; (7) recovering haemoglobin previously lost in holdup volumes; (8) speeding red blood cell pooling and washing; (9) speeding deoxygenation and oxygenation; (10) reducing the use of expensive ingredients; (11) reducing overall production time; and (12) elimination of routine requirements for overtime. Because of the potentially conflicting nature of the objectives, and perhaps even the goals, an organization for the management of process improvement was established and a commitment to current good manufacturing procedures was made.

Review of records from production runs at Letterman in 1991 and 1992 led to the recognition that 37% of runs were lost because of contamination by pyrogens, and the most significant physical loss of the product was in the holdup volumes of tanks and tubing. Engineering solutions to these problems included the application of full sterilize-in-place capability for the cross-flow filtration system and alterations in filtration and holdup volumes. Laboratory quality control assured reproducible equipment sterility and no increase in haemoglobin denaturation with reduced fluid volumes.

Other product purity issues were addressed in the alteration of the red blood cell washing process, attention to factors reducing methaemoglobin formation, elimination of HEPES buffer in the cross-linking process, and better handling of the cross-linking reagent. The changes reflect scientific, engineering, quality management, and economic decisions and are discussed separately below.

Outdated units of RBCs are now pooled into a sterile holding tank on the first day. The separation of the pooling step allows the production of stroma-free haemoglobin to take place within a single 8-hour work shift on the second day. Pooling clinically incompatible red blood cells does not lead to agglutination or lysis or to increased concentrations of red blood cell phospholipids in the final product. Opening the RBC storage bags a day earlier caused no detectable increase in bacterial or endotoxin contamination.

To avoid methaemoglobin formation, the haemoglobin modification process takes advantage of the thermodynamic stability afforded by low temperature, pH control, and deoxygenation. Engineering changes now keep the process at 5°C except for deoxygenation, cross-linking, and heat treat-

ment. Low pH is avoided and the heat denaturation process is carried out at pH 6.9. Deoxygenation is critical for two reasons. First, it forces the haemoglobin to be in the proper configuration for cross linking between the  $\alpha$ -lysine-99s<sup>14</sup> and second, it prevents oxidation during the high temperature denaturation of impurities at the end of cross-linking.<sup>15</sup> The speed of deoxygenation and reoxygenation are important because the methaemoglobin produced is enhanced when haemoglobin is in the partially oxygenated state.<sup>16</sup> Faster conversion from oxyhaemoglobin to deoxyhaemoglobin and back reduces the presence of unstable partially oxygenated haemoglobin. A single pass through one gas exchange membrane, a clinical membrane oxygenator with nitrogen as the gas medium, fails in removing all of the oxygen from the solution. Continual cycling through the gas exchange membrane is required for complete deoxygenation. The time required for oxygen removal has been reduced from 3 to 1.5 h with two membrane oxygenators in series. For reoxygenation, a single pass through one gas exchange membrane with oxygen as the gas medium results in complete oxygenation, eliminating the requirement for dilution into 400 litres of oxygenated buffer. Along with the new deoxygenation and oxygenation procedures, success in gently handling the molecule has resulted in only 2–3% methaemoglobin in the final product.

In published descriptions of the cross-linking of haemoglobin with DBBF, HEPES buffer was used for both its buffering capability and as a solvation medium for DBBF. However, HEPES is not a U.S.P. listed product, and its presence raises questions about its toxicity. Haemoglobin itself as well as the STP "blocking" agent are adequate buffers at the pH used (7.0) and the solvation of DBBF in HEPES prior to exposure to a haemoglobin solution is not required for the cross linking reaction.<sup>14</sup> Therefore, HEPES buffer has been removed from the manufacturing process.

The chemical purity of the  $\alpha\alpha$ -cross-linked haemoglobin product, uncontaminated by uncross-linked haemoglobin or by further modified cross-linked haemoglobin, is related to the ability to deliver the intact cross-linking agent in the correct stoichiometry under the correct conditions. To understand the optimization of the cross-linking of haemoglobin, a description of the reaction of DBBF with haemoglobin is necessary.

The intramolecular cross-linking of haemoglobin is accomplished by a nucleophilic displacement

reaction involving the cross-linker, DBBF, and the side-chain of lysine. DBBF is a diester with very efficient leaving groups in the dibromo-aspirins. The side-chain amine group of lysine with its lone pair of electrons attacks one of the carbonyl groups of fumarate. The dibromo-aspirin leaves, and an amide bond is formed with the fumarate. The same nucleophilic displacement reaction occurs at the opposite end of the DBBF, yielding a final product of intramolecularly cross-linked haemoglobin.

Several factors contribute to the specificity of the cross linking between DBBF and deoxyhaemoglobin. Solution conditions, protein conformation, allosteric effectors, and alternate site blockers all help to increase the yield of the cross-linking reaction.<sup>14</sup> In addition, specific interactions between DBBF analogues and haemoglobin have been observed by X-ray crystallography that position the DBBF optimally for cross linking at the  $\alpha$ -lysine-99 site.<sup>17</sup>

Of the 44 lysines in haemoglobin that potentially react with DBBF, only a few are active. In analysing the final product, only  $\alpha$ -lysine-99,  $\beta$ -NH<sub>2</sub> and  $\beta$ -lysine-82 react substantially with DBBF.<sup>16</sup> The major reason for this specificity is probably the high value of the pK<sub>a</sub> of the lysine side-chain amine. With a pK<sub>a</sub> of 10.8 in aqueous solution, free lysine is highly protonated under neutral conditions. Since the reaction conditions are maintained at pH 6.9, lysines exposed to the aqueous medium are largely protonated. With a proton associated with the lone pair of electrons, lysine cannot attack the fumarate carbonyl groups of DBBF. Thus, lysines that are on the periphery of the haemoglobin molecule are unreactive toward the DBBF. Lysines buried inside the haemoglobin are simply inaccessible to the DBBF. Only  $\alpha$ -lysine-99,  $\beta$ -NH<sub>2</sub> and  $\beta$ -lysine-82, all in the central cavity of haemoglobin, are accessible. The increased hydrophobic environment of the cavity favours the neutral form of lysine and effectively lowers the pK<sub>a</sub> of these lysines. With the proton now removed, these lysines can effectively react with the DBBF. The use of a  $\beta$ -cleft blocker (STP) effectively blocks the  $\beta$ -NH<sub>2</sub> and the  $\beta$ -lysine-82 sites. Acidic conditions (pH < 7), though potentially causing increased oxidation, must be used in order for the STP to bind efficiently within the beta cleft.

As mentioned previously, chloride and CO<sub>2</sub> act as allosteric effectors of haemoglobin. The chloride interaction involves several binding sites that include  $\alpha$ -lysine-99. This reaction elevates the

population of protonated lysines, rendering the amino acid inactive for the cross-linking reaction. Therefore, chloride is removed from the reaction mixture.

The cross-linking reaction between  $\alpha$ -lysine-99s only occurs with haemoglobin that is not carrying oxygen. If oxygen is present, the haemoglobin changes conformation to its higher affinity form. In this form, the  $\alpha$ -lysine-99s are no longer available and a different reaction occurs cross-linking the  $\beta$ -chains between the  $\beta$ -lysine-82s. This creates a modified haemoglobin that gives up oxygen less readily.<sup>19</sup> Because of this competing reaction, the desired reaction is performed with the solution fully deoxygenated and with a blocking compound occupying the alternative cross-linking site in the space between the  $\beta$ -chains.

Finally, the cross-linking agent, DBBF, is unstable in water. It is susceptible to hydrolysis that can be catalysed both by acidic or basic conditions. Since DBBF has two reactive sites, hydrolysis at one reactive site of the DBBF renders it incapable of intramolecular cross-linking. However, the second unhydrolysed reactive site of DBBF is still capable of reacting with lysine sites on the haemoglobin. Prevention of DBBF hydrolysis becomes a high priority to ensure intramolecular cross-linking and deter reactions with partially hydrolysed DBBF. As conjugate bases and acids hydrolyse DBBF, DBBF is rapidly added to deionized pyrogen-free water, and the slurry is then immediately transferred to the bioreactor to minimize hydrolysis of the cross-linking reagent. Deoxygenation of the slurry is not performed because the oxygen dissolved in the pyrogen free water of the slurry, about 9 ml, would only oxygenate 0.2% of the haemoglobin and thus does not affect the process yield. In fact, the small amount of oxygen present may account for the substantial decrease in the unmodified product. Unmodified haemoglobin has a higher affinity for oxygen than  $\alpha\alpha$ -cross-linked product and is more likely to bind oxygen. Oxygenated haemoglobin denatures more rapidly than deoxygenated haemoglobin.<sup>15,20</sup> Therefore, the small amounts of oxygen may enhance the denaturation of undesired material. The homogeneity of the cross-linked product can be ascertained with anion exchange FPLC [see Figs 6(a) and 6(b)]. By preserving the integrity of the DBBF, synthesis of pure  $\alpha\alpha$ Hb as measured by FPLC has increased from 50 to 90+% with a significant increase in overall product yield.

Better understanding of the cross-linking reaction chemistry and the implementation of current good

manufacturing practices have allowed substantial increases in the purity and yield of the modified hemoglobin product. The high specificity of this reaction and the potential for further refinement was not realized until the process changes were undertaken. Making very precise chemical modifications of a globular protein is possible.

This increased understanding and control of the reaction chemistry and the production process has led to savings of time and money. Saving time feeds back into product quality by reducing the exposure of hemoglobin to denaturing environments. Saving money occurs through reduced raw material, process, and labour costs and a reduced potential for mishaps. Freed resources can be used in other parts of the development program.

This report documents the recent progress of work originally begun by Winslow and Chapman<sup>5</sup> to produce a model modified hemoglobin solution of high purity to advance the development of oxygen-carrying resuscitation fluids. It shows that current good manufacturing practice production of biological material can be carried out effectively and efficiently in the public sector. It shows the potential for very specific and high yield chemical modification of hemoglobin.

#### Acknowledgements

The opinions expressed herein are the private views of the authors, and are not to be construed as official or as reflecting the views of the U.S. Department of the Army or of the U.S. Department of Defense.

#### References

1. Winslow RM. Hemoglobin-based Red Cell Substitutes. Baltimore, MD. Johns Hopkins University Press, 1992.
2. Rudolph AS. Encapsulation of hemoglobin in liposomes. In: Blood Substitutes: Physiological Basis of Efficacy, Birkhäuser, Boston MA, Winslow RM, Vandegriff KD, Intaglietta M, eds, 1995: 90-104.
3. Regan RF, Panter SS. Neurotoxicity of hemoglobin in cortical cell culture. *Neurosci Lett* 1993; 153(2): 219-222.
4. Manning LR, Jenkins WT, Hess JR *et al.* Subunit dissociations in natural and recombinant hemoglobins. *Protein Sci* 1996; 5: 775-781.
5. Winslow RM, Chapman KW. Pilot-scale preparation of hemoglobin solutions. In: Methods in Enzymology Vol. 231, Hemoglobins Part B: Biochemical and Analytical Methods, Academic Press, San Diego, CA, Everse J, Vandegriff KD, Winslow RM, eds. 1994: 3-16.
6. Dickerson RE, Geis I. Hemoglobin: Structure, Function, Evolution, and Pathology. The Benjamin/Cummings Publishing Company, Inc., Menlo Park, CA, 1983.
7. Hill AV. The possible effects of the aggregation of the molecules of hemoglobin on its oxygen dissociation curve. *J Physiol (Lond)* 1910; 40: 4-7.
8. Imai K. Allosteric Effects in Hemoglobin. Cambridge University Press, New York, 1982.
9. Nagel RL, Gibson QH. The binding of hemoglobin to haptoglobin and its relation to subunit dissociation of hemoglobin. *J Biol Chem* 1971; 246: 69-73.
10. Ip SHC, Johnson ML, Ackers GL. Kinetics of deoxyhemoglobin subunit dissociation determined by haptoglobin binding: estimation of the equilibrium constant from forward and reverse rates. *Biochemistry* 1976; 15: 654-660.
11. Walder RY, Andracki ME, Walder JA. Preparation of Intramolecularly Cross-Linked Hemoglobins. In: Methods in Enzymology Vol. 231, Hemoglobins Part B: Biochemical and Analytical Methods, Academic Press, San Diego, CA, Everse J, Vandegriff KD, Winslow RM, eds. 1994: 274-280.
12. Faassen AE, Sundby SR, Panter SS *et al.* Hemoglobin: a lifesaver and an oxidant. How to tip the balance. *Biomater Art Cells Art Org* 1988; 16(1-3): 93-104.
13. International Committee for Standardization in Haematology. Recommendations for reference method for haemoglobinometry in human blood (ICSH Standard EP 6/2: 1977) and specifications for international hemoglobin cyanide reference preparation (ICSH Standard EP 6/3: 1977). *J Clin Pathol* 1978; 31: 139-143.
14. Chatterjee R., Welty EV, Walder RY *et al.* Isolation and characterization of a new hemoglobin derivative cross-linked between the  $\alpha$  chains (Lysine 99 $\alpha_1$   $\rightarrow$  Lysine 99 $\alpha_2$ ). *J Biol Chem* 1986; 261: 9929-9937.
15. Estep TW, Bechtel MK, Miller TJ *et al.* Virus inactivation in hemoglobin solutions by heat. *Biomater Art Cells Art Org* 1988; 16(1-3): 129-134.
16. Abugo OO, Rifkind JM. Oxidation of hemoglobin and the enhancement produced by nitroblue. *J Biol Chem* 1994; 269: 24845-24853.
17. Perutz MF, Fermi G, Abraham DJ *et al.* Hemoglobin as a receptor of drugs and peptides: X-ray studies of the stereochemistry of binding. *J Am Chem Soc* 1986; 108: 1064-1078.
18. Jones RT. Structural characterization of modified hemoglobins. In: Methods in Enzymology Vol. 231, Hemoglobins Part B: Biochemical and Analytical Methods, Academic Press, San Diego, CA, Everse J, Vandegriff KD, Winslow RM, eds. 1994: 322-343.
19. Walder JA, Walder RY, Arnone A. Development of antisickling compounds that chemically modify hemoglobin S specifically within the 2,3-diphosphoglycerate binding site. *J Mol Biol* 1980; 141: 195-216.
20. Olsen KW. Thermal denaturation procedures for hemoglobin. In: Methods in Enzymology Vol. 231, Hemoglobins Part B: Biochemical and Analytical Methods, Academic Press, San Diego, CA, Everse J, Vandegriff KD, Winslow RM, eds. 1994: 514-524.

Received for publication 9 October 1996;

accepted 10 January 1997

## BLOOD COMPONENTS

## Effect of 24-hour storage at 25°C on the in vitro storage characteristics of CPDA-1 packed red cells

J.P. Ruddell, L.E. Lippert, J.G. Babcock, and J.R. Hess

**BACKGROUND:** Packed red cells (RBCs) warmed above 10°C are generally discarded. Few data exist on the degree of accelerated metabolism and increased hemolysis of packed RBCs allowed to warm.

**STUDY DESIGN AND METHODS:** Twenty-four CPDA-1 packed RBC units were combined in 3-unit pools and subdivided into 2 test units and a control unit. One test unit from each pool was warmed to 25°C for 24 hours on Day 6 and the other test unit was warmed on Day 20; control units were maintained at 1 to 6°C. RBC and supernatant chemistries and RBC morphology were measured weekly (Days 0, 7, 14, 21, and 28) and on the day before warming (Days 6 and 20).

**RESULTS:** Warming CPDA-1 packed RBCs accelerated the catabolism of glucose 10-fold and produced concentrations of glucose, lactate, and ATP after 25 days of storage that were equivalent to those in unwarmed units at 35 days. Supernatant sodium and potassium concentrations were corrected partially with warming. RBC morphology transiently normalized with warming and without increased hemolysis; no bacteria growth was detected.

**CONCLUSION:** One day of 25°C storage of CPDA-1 packed RBCs accelerates essential metabolite breakdown equivalent to 10 days of storage at 1 to 6°C. It does not appear to matter whether the packed RBCs are warmed on Day 6 or Day 20. This information may be useful in determining the acceptability of blood allowed to warm above 10°C.

The American Association of Blood Banks (AABB) and the Food and Drug Administration have established guidelines for the storage and preservation of packed red cells (RBCs). According to AABB Standards G1.300 and G2.000,<sup>1</sup> packed RBCs must be stored at temperatures between 1 and 6°C and shipped at temperatures between 1 and 10°C.<sup>1</sup> The Food and Drug Administration requires the same standards. The Code of Federal Regulations stipulates that blood may not be issued unless it has been stored at 1 to 6°C or maintained at 1 to 10°C during shipping.<sup>2</sup> It further stipulates that blood should be placed in storage at 1 to 6°C immediately after the separation of platelets.<sup>3</sup> Common practice is for RBCs stored at temperatures outside those ranges to be destroyed, though the AABB *Technical Manual* states, "Blood exposed to temperatures above 10°C is not necessarily unsuitable for transfusion."<sup>4(p155)</sup> There are few or no data that support either the destruction of such blood or its retention for transfusion, but the *Technical Manual* does mention an increased possibility of bacterial contamination.<sup>5</sup> This investigation provides data on the accelerated rate of depletion of metabolic support when RBCs are stored near ambient temperature (25°C) for a prolonged period (24 hours) either early (Day 6) or late (Day 20) in the shelf-life of a CPDA-1 packed RBC unit.

**ABBREVIATIONS:** AABB = American Association of Blood Banks, Hb = hemoglobin; RBC(s) = red cell(s).

From the US Army Blood Research Laboratory, Walter Reed Army Institute of Research and the Department of Pathology, Walter Reed Army Medical Center, Rockville, Maryland.

The opinions expressed herein are the private views of the authors and are not to be construed as official or as reflecting the views of the US Department of the Army or of the US Department of Defense.

Supported in part by the US Army Medical Research and Materiel Command.

Received for publication June 18, 1997; revision received October 20, 1997, and accepted November 4, 1997.

TRANSFUSION 1998;38:424-428.

## MATERIALS AND METHODS

### Donor screening

Twenty-four volunteers, 10 women and 14 men who met all AABB and FDA blood donor criteria and whose blood was further screened and found not to have hemoglobin S (HbS), alloantibodies, or abnormal osmotic fragility, donated a full unit of blood for this study. All volunteers gave their informed consent in accordance with a protocol approved by the Institutional Review Board at Walter Reed Army Institute of Research.

### Packed RBCs

Blood (450 mL) was collected into a CPDA-1 double-bag system (4R6210, Fenwal Division, Baxter Healthcare Corp., Deerfield, IL) and held at ambient room temperature before processing. Packed RBCs were prepared within 2 hours of whole-blood collection by centrifugation at  $5000 \times g$  for 5 minutes at room temperature and removal of plasma to achieve an average hematocrit of 67 percent (range, 66-68%). Three units of packed cells of the same ABO group were pooled by serial sterile connections to a 1.0-L transfer bag (4R6210, Fenwal). The contents were mixed and divided by weight into three aliquots in 400-mL satellite bags (PL-146) from a CPDA-1 quadruple-bag collection system (4R6423R Fenwal) connected by use of a sterile connecting device (SCD312 Sterile Tubing Welder, Terumo Medical Corp., Elkton, MD) to the pooling bag. The pooled packed cells were mixed by gentle inversion of the transfer bag along its long axis at least 15 times. All transfers to or from the pooling bag were made by gravity. The three aliquots from each pool—the Day 6 early-warmed test unit, the Day 20 late-warmed test unit, and the control unit—were placed in refrigerated storage (1-6°C) within approximately 4 hours of collection and stored continuously at 1 to 6°C in a monitored refrigerator, except during the planned warming periods.

### Sampling

Samples were taken at the time of pooling (Day 0) from each of the eight pools; all other samples were taken from the 24 individual units. A sampling site coupler (4C2405, Fenwal) was used to collect samples from the pools on Day 0 and from the test and control units on Day 35. An alternative method was used to collect the intervening samples on Days 6, 7, 14, 20, 21, and 28. Briefly, a length of integrally attached tubing was filled with mixed blood and clamped approximately 2 inches from the distal end. The distal end was cut with scissors and the clamp was released while light pressure on the blood bag was maintained. The required amount of sample was expelled, and the tubing was resealed and heat-sealed proximal to the clamp. The tubing was then restripped and resealed. All sampling was performed in a biological safety cabinet (Model #NU 408FM-400, Nuair, Plymouth, MN).

### Incubation of test units

On Day 6, all test and control units from each pool were sampled; test units labeled for early warming were removed from refrigerated storage and placed in a 25°C incubator for 24 hours. On Day 7, at the end of the incubation, all test and control units were sampled and returned to refrigerated storage. On Day 20, all test and control units were sampled again; this sampling was followed by warming (25°C, 24 hours) of those units designated late-warmed test units. On Day 21, at the end of the incubation, all units were again sampled and returned to refrigerated storage.

### Testing

The pH of the packed RBCs was measured with a clinical blood gas analyzer (855 Blood Gas Analyzer, CIBA-Corning, Medfield, MA). The Hb and Hct were measured with a clinical hematology analyzer (Cell Counter System Series 9000, Baker Hematology, Allentown, PA); plasma sodium and potassium were determined by using ion-specific electrodes in a clinical chemistry analyzer (Cobas Fara, Roche Diagnostic Systems, Nutley, NJ), all in accordance with manufacturer's directions. Whole-blood glucose, total ATP, and lactate levels were obtained from deproteinized samples. Briefly, proteins in whole-blood samples were precipitated with 12-percent perchloric acid on ice, and the supernatant was harvested after centrifugation at  $2700 \times g$  for 10 minutes. The portion of the supernatant used for glucose and ATP testing was adjusted to pH 8 to 9 with solid  $\text{KHCO}_3$ . The remainder of the deproteinized sample was used for lactate testing and the pH was not adjusted. Glucose levels were determined spectrophotometrically in the Cobas Fara. Total ATP was assayed enzymatically with a commercially available test kit (Kit # 35-B, Sigma Diagnostics, St. Louis MO). ATP levels were reported as  $\mu\text{mol per g}$  of Hb. The lactate levels were measured with a commercially available quantitative lactate kit (#228, Sigma Diagnostics) adapted to a clinical chemistry analyzer (Roche).

The RBC morphology score was determined according to the method of Usry et al.<sup>6</sup> Briefly, the RBCs were fixed with glutaraldehyde, examined microscopically, and categorized into one of six morphologic types, ranging from discocyte to spherocyte. After at least 200 cells were categorized, the number of each morphologic type was multiplied by a weighting factor, ranging from 1.0 for the discocyte to 0.0 for the spherocyte; the summed weighted score was divided by the number of cells scored and reported as a percentage.

The plasma or supernatant Hb was measured spectrophotometrically at 540 nm by the method of Moore et al.,<sup>7</sup> which adapts the classical cyanmethemoglobin method to the lower levels of Hb found in the plasma or supernatant of stored blood. The supernatant (plasma) Hb level was divided by the total Hb level and multiplied by 100 to determine the percentage of hemolysis, by the formula:

% Hemolysis = (supernatant Hb in g/dL/total Hb in g/dL) × 100.

### Sterility

The sterility of all aliquots was assessed in two ways. The first was by visual comparison of the contents of a filled tubing segment prepared soon after collection and the contents of the bag, for any color changes or appearance of bubbles on all sampling days. In the second method, a commercially available blood culture system (Septi-Chek Blood Culture Bottle and Slide, Becton Dickinson Microbiology Systems, Cockeysville, MD) was used on Day 35 of storage to determine if bacteria growth was present.

### Data analysis

One-way ANOVA was used to analyze the data. Two comparisons were made. First, the Day 35 means of all values for all three groups were compared. In the second comparison, the Day 28 means of the test groups were compared to the Day 35 mean of the control group for each value. Comparisons with probabilities less than 0.05 were considered significant.

## RESULTS

Under all conditions of storage, the extracellular glucose concentration decreased with time. During 35 days of storage at 1 to 6°C, the mean glucose concentration declined from  $391 \pm 4$  to  $72 \pm 13$  mg per dL, averaging a decline of about 9.1 mg per dL per day (Fig. 1A). The glucose concentration declined at the much greater mean rates of 90 mg per dL per day on the days of 25°C storage,  $111 \pm 5$  mg per dL on Day 6, and  $70 \pm 2$  mg per dL on Day 20. This caused the glucose concentrations to be significantly lower in the warm-stored test units at all time points after storage. Increases in plasma lactate and decreases in pH followed the changes in glucose concentration (Fig. 1B and 1C).

The ATP concentrations showed a more complex pattern, initially increasing during the first week of storage and decreasing thereafter (Fig. 1D). The rates of decrease in ATP concentration were observed to be greater in the week after warming than in the continuously refrigerated control. Thus, the unwarmed control units had a significantly higher mean ATP concentration on Day 35 ( $2.4 \pm 0.1$   $\mu\text{mol/g Hb}$ ) than the warmed test units had on either Day 28 ( $1.9 \pm 0.1$   $\mu\text{mol/g Hb}$ ,  $p = 0.012$ ) or Day 35 ( $1.4 \pm 0.1$   $\mu\text{mol/g Hb}$ ,  $p < 10^{-7}$ ). One warm-stored test unit had an ATP concentration of 1.4  $\mu\text{mol per g of Hb}$  on Day 28; all others were 1.7  $\mu\text{mol per g of Hb}$  or greater.

Mean supernatant plasma Hb concentrations appeared to increase after warming, especially in the units warmed on Day 20, but the differences between the warmed (test) and control units never achieved significance (Fig. 1E). Hemolysis never exceeded 1 percent. Small in-

creases in extracellular sodium and decreases in extracellular potassium that occurred during the warm-storage days persisted through most of storage (Figs. 1F and 1G).

Warming led to significant improvement in RBC morphology scores during the 24 hours of warming, but the improvement was not maintained in subsequent weeks (Fig. 1H). On Day 35, the morphology indexes of the three groups were not different. A comparison of the relative numbers of the morphologic forms of RBCs seen before and after warming on Day 20 showed the reappearance of greater numbers of less-deformed RBCs and disappearance of the more spicular echinocytes. There was no corresponding increase in supernatant Hb to suggest lysis.

Visual examination of all pools and all test and control units revealed no abnormalities that might have indicated bacterial contamination. Broth cultures of all units begun on Day 35 and examined for 4 days thereafter showed no bacteria growth.

## DISCUSSION

Liquid storage systems for packed RBCs are licensed for their ability to preserve cells at 1 to 6°C. Efforts to ensure the quality of these RBC components have led to standards and regulations stipulating that blood be stored in continuously monitored refrigerators at 1 to 6°C and transported on wet ice so that its temperature would not rise above 10°C.<sup>1,2</sup> The rule of thumb that has evolved maintains that blood which is outside of a refrigerator for more than 30 minutes should be discarded, because the temperature will have risen above 10°C. The net effect of these rules is to ensure that each unit of blood has been handled in a highly standardized way that has been demonstrated to meet accepted criteria for viability and circulation of posttransfusion RBCs.

Rigid enforcement of these standards, in the face of the knowledge that "exposure to temperatures above 10°C does not necessarily render blood unsuitable for transfusion,"<sup>4(p155)</sup> may lead to several undesirable effects. First, units of blood are regularly discarded for potentially insignificant deviations from the standards. This has led to the proliferation of devices to measure the temperature of blood units that are outside of the refrigerator for short periods. Second, the reluctance to remove blood from monitored refrigeration because of concerns about potential violation of the standards sometimes compromises the availability of blood at scenes of emergency care, even in major hospitals. Third, in military and civil emergency situations, no information is available to the medical directors of blood services about the safety implications for recipients of blood stored in current storage solutions under nonstandard conditions.

Refrigeration preserves RBCs because glycolysis and other metabolic processes are slower at lower temperatures. At 37°C, RBCs consume glucose at a rate of 0.014 to 0.028

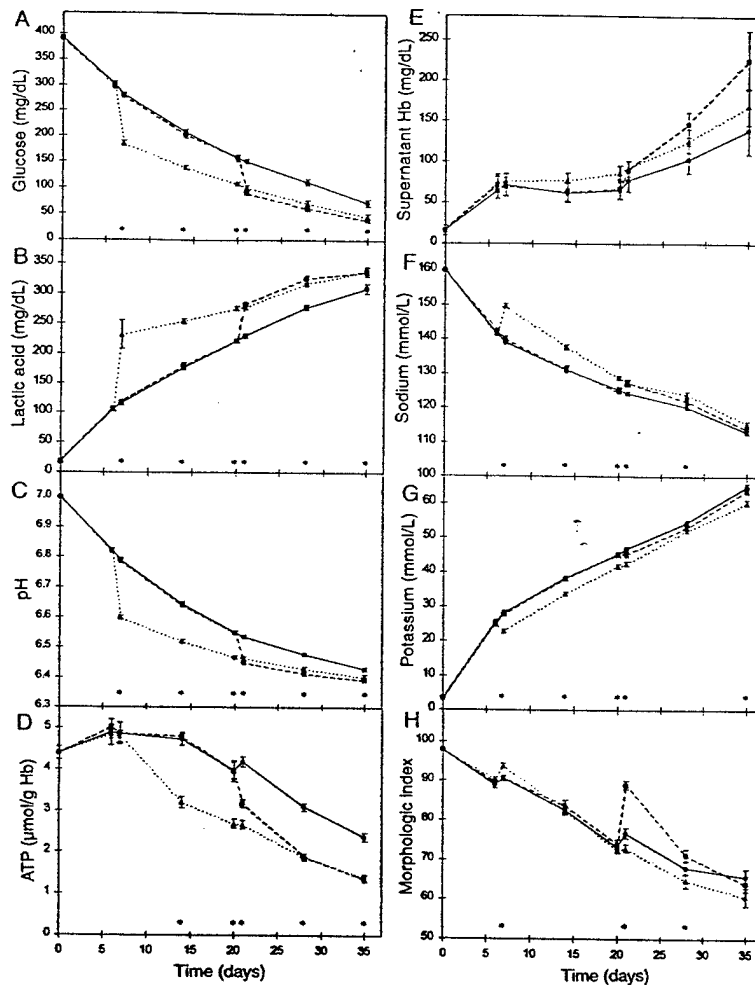

Fig. 1. Concentrations of metabolites, metabolite by-products, supernatant Hb, supernatant electrolytes, and the morphologic index of CPDA-1 packed RBCs either warmed at 25°C for 24 hours at Day 6 (test) (---▲---) or Day 20 (---■---) or stored continuously at 1 to 6°C (control) (—●—). \*, the time points where differences in group means could not be due to chance alone at a probability of  $p = 0.05$ . Error bars depict  $\pm$  SEM.

$\mu\text{g}$  per hour per  $10^6$  RBCs,<sup>8</sup> which is equivalent to a decrease of 7 to 14 mg per dL per hour in the extracellular glucose concentration of packed RBCs stored in CPDA-1 at a hematocrit of 67 percent. Thus packed RBCs stored at body temperature in CPDA-1 would be expected to consume all of the available glucose in 1 to 3 days. Cooling to 1 to 6°C reduces the rate at which extracellular glucose concentration is consumed to the observed 9 mg per dL per day and allows storage for 35 days. Intermediate temperatures should be associated with intermediate rates of glucose consumption and intermediate periods of effective storage.

We performed this work to quantitate the acceleration in consumption of glucose and the resulting changes in cellular ATP concentration that occur with increased storage temperature. Our inspiration was the work of Shields,<sup>9</sup> who in 1970 showed that, for whole blood stored in ACD, a day at 22 to 25°C reduced RBC recovery measured with  $^{51}\text{Cr}$  by an amount equivalent to the recovery after about a week of 1 to 6°C storage. Because of the large interdonor variation in blood storage characteristics, Shields was able to demonstrate significant differences in recovery only at times beyond the conventional expiration of the units at 21 days. In our study, measuring the metabolite concentrations in aliquots of pooled units allowed the accurate assessment of differences resulting from changes in storage conditions. However, pooling precludes autologous RBC recovery and survival measurements, and estimates of the clinical significance of this work depend on the implications that can be drawn from the cellular ATP concentrations and morphologic measures.<sup>10</sup>

The relationship of cellular ATP concentrations to a 24-hour RBC recovery of 75 percent is probably better understood for CPDA-1 than for any other storage solution. First, in the CPDA-1 licensing study,<sup>11</sup> the mean ATP concentration was 1.93  $\mu\text{mol}$  per g of Hb. Second, Beutler and West<sup>12</sup> have shown that removing glucose from CPDA-1 units by removing plasma reduces 24-hour posttransfusion survival. Third, adding more glucose and adenine to CPDA-1, as is

done with the preservative solution CPDA-2,<sup>13</sup> produces a solution that allows RBCs to be stored for a week longer, with equivalent recovery and survival. Thus, the survival of RBCs stored in CPDA-1 is glucose- and ATP-limited, and is most highly correlated with maintaining ATP concentrations above a value of about 2  $\mu\text{mol}$  per g of Hb.<sup>11</sup>

The morphologic changes in the RBCs that we observed with warming and recooling were striking. During storage in the cold, RBCs slowly evolve from biconcave discs to sharply spicular echinocytes. These changes revert with warming, but after recooling, their reappearance is accel-

erated. Thus, the cellular injury that underlies the morphologic changes has both reversible and irreversible aspects. Electron micrographs of microvesicles budding from the tips of echinocytic spicules<sup>14</sup> suggest a relationship between RBC shape change and the loss of RBC membrane area that is critical for survival. Warming may provide a model for studying the mechanism of these events.

We have described the effects of a specific time and temperature stress on the performance of the CPDA-1 storage system. Interpolation can serve as a basis for estimates of the effects of stresses of shorter duration or lower temperatures. Thus, if the catabolism of glucose and ATP is a linear function of the time of exposure to the temperature stress, then a single 2-hour exposure to 25°C might be expected to reduce the storage life of a unit of CPDA-1 RBCs by a day. The study also provides a model for measuring the robustness of storage systems and for determining the circumstances under which a measurable effect will be achieved. Small variances from the current standards of practice, such as exposure to temperature of less than 25°C for periods of less than 2 hours, are unlikely to have measurable influence on the quality of the component. If medical directors are called upon to provide blood in emergencies, the study provides some information to guide them in deciding the extent of attempts to take advantage of the performance characteristics of the storage system in their efforts to maximize the availability of blood to save lives.

The authors are not advocating the abandonment of current standards for RBC storage. Those standards provide excellent assurance of the physiologic quality of stored cells, as well as protection against the uncommon event of bacterial contamination. While we saw no evidence of bacterial contamination with broth culturing of all 24 units, even in the face of repeated sampling that began in the first week of storage, data from a small number of units collected in a research setting cannot be applied to clinical blood bank practice.<sup>15,16</sup> Any attempt to take advantage of the performance characteristics of current storage systems through nonstandard usage must be accompanied by heightened vigilance.

#### ACKNOWLEDGMENTS

The authors express their appreciation for the outstanding technical assistance provided by Claudia Derse-Anthony and Michael Mechling.

#### REFERENCES

1. Klein HG, ed. Standards for blood banks and transfusion services. 17th ed. Bethesda: American Association of Blood Banks, 1996.
2. CFR 21: Part 640.4(e)(3).
3. CFR 21: Part 640.4(f).
4. Vengelen-Tyler V, ed. Technical manual. 12th ed. Bethesda: American Association of Blood Banks, 1996.
5. Walker RH, ed. Technical manual. 11th ed. Bethesda: American Association of Blood Banks, 1993:68.
6. Usry RT, Moore GL, Manalo FW. Morphology of stored, rejuvenated human erythrocytes. *Vox Sang* 1975;28:176-83.
7. Moore GL, Ledford ME, Merydith A. A micromodification of the Drabkin hemoglobin assay for measuring plasma hemoglobin in the range of 5 to 2000 mg/dl. *Biochem Med* 1981;26:167-73.
8. Guest GM, Mackler B, Graubarth H, Ammentorp PA. Rates of utilization of glucose in erythrocytes and leucocytes. *Am J Physiol* 1953;172:295-300.
9. Shields CE. Studies on stored blood. IV. Effects of temperature and mechanical agitation on blood with and without plasma. *Transfusion* 1970;10:155-62.
10. Meryman HT, Hornblower M, Syring R, Mesbah-Karimi N. Extending the storage of red cells at 4°C. *Transfus Sci* 1994;15:105-15.
11. Zuck TF, Bensinger TA, Peck CC, et al. The in vivo survival of red blood cells stored in modified CPD with adenine: report of a multi-institutional cooperative effort. *Transfusion* 1977;17:374-82.
12. Beutler E, West C. The storage of hard-packed red blood cells in citrate-phosphate-dextrose (CPD) and CPD-adenine (CPDA-1). *Blood* 1979;54:280-4.
13. Moore GL. Red blood cell preservation: a survey of recent research. In: Sohmer PR, Schiffer CA, eds. Blood storage and preservation. A technical workshop. Arlington: American Association of Blood Banks, 1982:9-22.
14. Greenwalt TJ, Bryan DJ, Dumaswala UJ. Erythrocyte membrane vesiculation and changes in membrane composition during storage in citrate-phosphate-dextrose-adenine-1. *Vox Sang* 1984;47:261-70.
15. Klein HG, Dodd RY, Ness PM, et al. Current status of microbial contamination of blood components: summary of a conference. *Transfusion* 1997;37:95-101.
16. Barrett BB, Andersen JW, Anderson KC. Strategies for the avoidance of bacterial contamination of blood components. *Transfusion* 1993;33:228-33.

#### AUTHORS

Jean P. Ruddell, MT(ASCP)SBB, MS, Student, Specialist in Blood Banking and Master of Science program (Blood Bank Fellowship), Department of Pathology, Walter Reed Army Medical Center, Rockville, MD; current address: Chief, Transfusion Service, 48<sup>th</sup> Medical Group, RAF Lakenheath, UK.

Lloyd E. Lippert, SBB(ASCP), PhD, Project Manager, US Army Blood Research Laboratory, Walter Reed Army Institute of Research, 1413 Research Boulevard, Rockville, MD 20850. [Reprint requests]

Janiine G. Babcock, MD, Deputy Commander, US Army Blood Research Laboratory, Walter Reed Army Institute of Research.

John R. Hess, MD, Commander, US Army Blood Research Laboratory, Walter Reed Army Institute of Research.

## Appendix 4

### **THE VIABILITY OF AUTOLOGOUS HUMAN RED BLOOD CELLS STORED IN ADDITIVE SOLUTIONS-5 AND EXPOSED TO 25°C FOR 24 HOURS**

T. J. Reid, J. G. Babcock, C. P. Derse-Anthony, H. R. Hill, L. E. Lippert, J. R. Hess Blood Research Detachment, Walter Reed Army Institute of Research, Washington, DC

The opinions expressed here in are the private vies of the authors, and are not to be construed as official or as reflecting the views of the U.S. Department of the Army or the U. S. Department of Defense. This is a U.S. Government work; there is no copyright.

Corresponding author: John Hess  
5606 Oak Place  
Bethesda, MD 20817  
Phone: (301) 295-4861 FAX: (301) 295-4628  
e-mail [COL John Hess@WRSMTP-ccMail.Army.Mil](mailto:COL_John_Hess@WRSMTP-ccMail.Army.Mil)

Address reprint requests to:  
COL John R. Hess  
Blood Research Detachment  
Walter Reed Army Institute of Research  
Washington, DC 207307-5100

This research was supported by the Combat Casualty Care Program of the U.S. Army Medical Research and Material Command

Running Head: Viability of RBCs stored at 25°C

**ABSTRACT:**

**BACKGROUND:** No data exist on the viability of RBCs stored in modern additive solution systems and allowed to warm above 10°C.

**STUDY DESIGN AND METHODS:** In a randomized cross-over study, three units of blood were collected at least 8 weeks apart from 11 volunteer donors and stored in additive solution-5 (AS-5). One unit from each volunteer was stored 1) for 6 weeks at 4°C, 2) for 5 weeks 4°C except for 24 hours at 25°C on day 14, and 3) for 5 weeks at 4°C except for 24 hours at 25°C on day 28. Units were sampled periodically during storage and at the end of storage viability was measured by the  $^{99m}\text{Tc}/^{51}\text{Cr}$  double label method.

**RESULTS:** RBC viability was not significantly different between storage protocols. Less than 1% of stored cells hemolysed. RBC ATP concentrations at the end of storage correlated with viability and were approximately equal in the warmed units after 30 days storage and the conventionally stored units after 42 days.

**CONCLUSIONS:** The data suggest that RBCs stored in AS-5 and allowed to warm to 25°C for 24 hours lose about 12 days of their shelf-life.

**Key Words:** blood storage, temperature, AS-5, emergency medicine, disaster medicine, military medicine

## INTRODUCTION:

Red blood cells (RBCs) are normally stored in the refrigerator and shipped on wet ice<sup>1</sup>. This practice maintains the viability of transfused RBCs and limits bacterial growth. It has been codified in Food and Drug Administration (FDA) regulations<sup>2</sup>. These regulations state that RBCs may not be issued unless they have been stored at temperatures between 1-6°C and shipped at temperatures between 1-10°C.

There are no data available on the viability of RBCs stored in modern additive solutions at higher temperatures<sup>3</sup>. Such evidence might support changes in the regulations regarding storage, such as the recent extension of the room temperature holding time before the separation of platelets<sup>4,5</sup>. Performance-based standards and regulations are expected to improve the availability of blood in emergency rooms and surgical suites while reducing the destruction of units issued and returned. Such data may also allow medical directors to make evidence-based decisions about the usability of RBCs following non-standard storage in emergencies.

This study provides data on the viability and concentrations of metabolites of RBCs stored in AS-5 and exposed to 25°C for 24 hours on day 14 or day 28. The data are consistent with the idea that RBCs lose viability as they lose adenosine triphosphate (ATP) content. The data further suggest that a day of room temperature storage reduces the viability of AS-5 stored RBCs equivalent to 12 days in the refrigerator.

## MATERIALS AND METHODS:

### Volunteers

Fifteen healthy volunteers meeting standard blood donor criteria were enrolled after giving informed consent in accordance with a protocol approved the Institutional Review Board of Walter Reed Army Institute of Research and the U.S. Army's Human Subjects Research Review Board<sup>1</sup>. Volunteers were tested to exclude sickle hemoglobin trait (Sicklescreen, Pacific Hemostasis, Huntersville, NC) and abnormal osmotic fragility (Unopette Test 5830, Becton Dickinson, Rutherford, NJ).

### Study Design

The study was conducted using a crossover design. Each volunteer donated units of blood with at least eight weeks separating donations. The three units were assigned randomly to storage in the following manner: one unit for 6 weeks at 4°C, a second for 5 weeks 4°C except for 24 hours at 25°C on day 14, and the third for 5 weeks at 4°C except for 24 hours at 25°C on day 28. The primary outcome measurement was the viability, the fractional *in vivo* survival of the stored RBCs 24 hours after autologous reinfusion. Other measures included concentrations of nutrients, metabolites and supernatant hemoglobin in the storage solution or RBCs.

### Blood Unit Preparation

Four hundred fifty milliliters ( $\pm 10\%$ ) of blood were collected into CPD anticoagulant in the primary bag of an AS-5 triple bag system (Optisol<sup>TM</sup>, Terumo

Medical Corp. Somerset, NJ). Packed cells were prepared by centrifugation at 5000 x g for 5 minutes at room temperature followed by the removal of plasma and addition of the additive solution to achieve a target storage hematocrit of approximately 55%. All units were sampled for *in vitro* testing and placed in refrigerated storage (1-6°C) within two hours of collection. Test units were stored five weeks and control units for six weeks.

#### *In vitro* Measures

Samples from stored units were collected into a small pouch attached to the residual donor needle tubing using a sterile connecting device (SCD 312, Terumo Medical Corporation, Somerset, NJ). The battery of *in vitro* tests described below was performed for all units at the end of preparation, on days 13, 14, 21, 27, 28, and at the end of storage (day 35 for test units and day 42 for control units).

Blood pH was measured using a clinical blood gas analyzer (855 Blood Gas Analyzer, CIBA-Corning, Medfield, MA). Total hemoglobin (HGB) concentration, and RBC counts were measured with a clinical hematology analyzer (Hematology Cell Counter System Series 9110+, Baker, Allentown, PA). Supernatant HGB was measured spectrophotometrically using the modified micro-Drabkins assay<sup>6</sup>. Percent hemolysis was determined by the ratio of free to total hemoglobin. Centrifuged microhematocrits (Clay Adams, Becton-Dickinson, Rutherford, NJ, USA) were performed to ascertain stored unit volume fractions.

Glucose and ATP concentrations were measured in deproteinized supernatants. Whole blood or packed cell aliquots were mixed with cold, 10% trichloroacetic acid to precipitate blood proteins, centrifuged at 2700 x g for 10 minutes, and the protein free supernatant frozen at -80°C until tested. Glucose concentrations were determined with a clinical chemistry analyzer (Cobas Fara, Roche Diagnostic Systems, Nutley NJ). ATP was assayed enzymatically using commercially available test kits (Procedure 366-UV, Sigma Diagnostics, St Louis, MO). Glucose consumption was determined from pre- and post-storage concentrations and adjusted for RBC content.

#### Check for bacterial contamination

Three to four days prior to the end of storage, aliquots from each unit were tested for bacterial contamination in broth and agar cultures using a commercial blood culture system (Septi-Chek Blood Culture Bottle and Slide, Becton Dickinson Microbiology Systems, Cockeysville, MD). Absence of growth in the cultures were documented before the unit was sampled for reinfusion.

#### *In Vivo* Red Cell Survival Testing

After five or six weeks of storage, *in vivo* RBC survival was measured 24 hours after autologous reinfusion using a double radioisotope procedure<sup>7,8</sup>. In brief, a sample of the stored blood was labeled with <sup>51</sup>Cr. Concurrently, a fresh blood sample was collected from the volunteer and labeled with <sup>99m</sup>Tc. Carefully measured aliquots of the radiolabeled red cells were mixed and rapidly reinfused. Blood samples were

collected at timed intervals during the 30 minutes immediately following the reinfusion and again at 24 hours, 7 days and 14 days post-reinfusion. Radioactivity of the samples was measured in a single gamma counter (Wallac Model 1480, Turku, Finland) except for samples from two volunteers where the  $^{99m}\text{Tc}$  counts were performed in second counter (Wallac CLINGAMMA Model 1272, Turku, Finland). Gamma emissions from  $^{99m}\text{Tc}$  radiolabeled cells were measured in the samples collected during the 30 minutes following reinfusion and used to determine the RBC volume. The activity from  $^{51}\text{Cr}$  labeled cells was measured on all samples and used to calculate the recovery and survival of the reinfused RBCs.

#### Statistical Analysis

One-way analysis of variance was used to examine the relationships between viability and mode of storage and differences in viability among the donors. Analysis of covariance was used to examine the effect of end-of-storage RBC ATP concentration on these relationships. A probability of less than 0.05 was considered significant.

#### RESULTS:

Eleven of fifteen enrolled volunteers completed the study. One was removed from the study because of a persistently low hematocrit after the first donation, one moved from the metropolitan area, and two withdrew for personal reasons. The study

design produced close matching for baseline measures between control and test units drawn from each volunteer and for the groups as a whole.

Measures of metabolites and breakdown products of the stored cells were measured in the course of storage. The glucose concentration in the suspending solution decreased at an average rate of 7.4 mg/dL/day during storage at 4°C (Fig 1a). This rate corresponds to 0.028  $\mu$ M glucose/mL RBCs/hr. Warming the cells to 25°C increased the rate of glucose consumption 12 fold to 86 mg/dL/day. The pH decreased also and in a manner similar to the decrease in glucose concentration (Fig 1b). RBC ATP concentrations decreased more rapidly in the days after warming (Fig 1c). Mean RBC ATP concentrations in the warmed cells at 30 days of storage were approximately equal to those of the conventionally stored cells after 42 days. RBC ATP concentrations at the end of storage correlated with viability ( $r=.42$ ) varied in a manner that was highly donor-specific (Fig 2a,  $P=.007$ ). RBC ATP concentrations at the beginning of storage did not predict concentrations at the end of storage.

Three to four days before the end of the assigned storage period, all units were cultured for bacteria, and none showed evidence of contamination or growth. At the end of the assigned storage period, the mean fraction of hemolysed RBCs was less than 1% under all conditions of storage (Fig 1d).

The measured viability of the cells returned to the original donors at the end of storage did not vary in the three storage groups, either when calculated as the  $^{51}\text{Cr}$  single-label recovery or as the  $^{99\text{m}}\text{Tc}/^{51}\text{Cr}$  double-label recovery (Fig 3). Those values for the single-label method were  $79 \pm 2\%$  for conventionally stored cells,  $76 \pm 2\%$  for

cells warmed on day 14, and  $76 \pm 2\%$  for cells warmed on day 28. The double label method gave values that averaged 2.5% lower. The mean values were  $78 \pm 3\%$ ,  $75 \pm 2\%$ , and  $72 \pm 2\%$  for the control and early and late warming groups respectively.

There was a large variability in measured RBC viability between volunteers best seen in the single-label measurements (Fig 2b,  $P=0.003$ ). The viable mass of reinfused cells declined at about 1% per day for the first two weeks after reinfusion in all volunteers and under all conditions of storage.

## DISCUSSION

This study shows that RBCs stored in AS-5 and warmed to  $25^{\circ}\text{C}$  for 24 hours at either day 14 or 28 in the course of 35 days of  $4^{\circ}\text{C}$  storage have an *in vivo* recovery and survival that is not distinguishable from that of RBCs stored conventionally for 42 days. Nor do they display excessive hemolysis.

The study suggests that the decrease in viability associated with warming is caused by the temperature related acceleration of metabolism and the earlier onset of reduced pH and conditions that adversely effect the maintenance of RBC ATP concentrations. If the relationship between the loss of RBC ATP and viability is correct, then a day of storage at  $25^{\circ}\text{C}$  probably shortens the storage time by 12 days. RBCs stored under such conditions are expected to display the required 75% mean viability with less than 1% hemolysis. Then, by interpolation, 2 hours at  $25^{\circ}\text{C}$  probably shortens the storage time by a day or reduces the viability by an amount too

small to measure.

It seems likely that the observed effects of temperature on RBC viability measured here during storage in AS-5 also apply to the other additive solutions with the same volumes and composition, SAGM (saline, adenine, glucose, mannitol) and AS-1 (Adsol®, Baxter Healthcare, Roundlake, IL). We have reported measures of RBC ATP concentrations after normal and warm storage of RBCs in CPDA-1 and shown a similar effect<sup>9</sup>. AS-3 (Nutricel®, Medsep Corp, Covina, CA), an additive solution with the same constituents as CPDA-1 and the same volumes as AS-5, probably also works in the same manner.

“Blood that has been warmed is not necessarily unfit for transfusion,” according to the authors of the 12<sup>th</sup> edition of the AABB Technical Manual<sup>10</sup>. This observation probably reflects the work of Kendrick in World War II, who oversaw the air shipment of blood to Europe off ice, and of Shields in the 1960s, who performed experiments similar to ours using blood stored in ACD solution<sup>11,12</sup>. It also reflects an understanding to the temperature-dependent kinetics of RBC metabolism and bacterial growth. Nevertheless, the AABB Standards and the FDA Regulations state that, “RBCs may not be issued unless they have been stored at temperatures between 1-6°C and shipped at temperatures between 1-10°C.” The regulation has been widely interpreted to mean that RBCs that have spent more than 30 minutes out of the refrigerator and therefore might have warmed above 10°C, should be destroyed<sup>13</sup>. The actual data on which this “30-minute rule” was based showed that units of whole blood in plastic bags warmed to temperatures above 10°C in 45 to 60 minutes after

removal from blood bank refrigerators<sup>14</sup>. In the 9<sup>th</sup> edition of the Technical Manual, the justification for the rule was stated as, "Warming the blood beyond ... (10°C), even with subsequent cooling, tends to accelerate red cell metabolism, produce hemolysis, and may permit bacterial growth in the unit."<sup>15</sup>

The "30-minute rule" is a measurable and enforceable quality control standard. However, it is wasteful of blood and often limits the availability of blood at sites of critical care even in good hospitals. Surgeons rightfully complain. The 30-minute rule should be reconsidered in the light present knowledge and dealt with explicitly in future FDA regulations and AABB Standards. In the past, the FDA has not allowed alternative procedures for RBC storage under 21 CFR 640.120 where the temperature of RBCs exceeded 10°C. In the future, a revised 30-minute rule should lead to an evidence-based decision that is made within a framework of revised government regulations, accrediting agency standards, and facility guidelines by a technologist or the medical director regarding the safety and viability of the units in question, not to an automatic requirement for destruction.

In the mean time, this data probably has use only for medical directors making critical decisions about the safety of units accidentally exposed to room temperatures in the course of emergency situations where other blood of known safety and viability is not available. The present Standards provide excellent protection for the viability and bacteriologic safety of RBCs and should not be violated except in true emergencies.

## ACKNOWLEDGMENTS

The authors thank SPC Nathan Boyce and SGT Amnart Churukha for technical assistance in collection and analysis of the data.

## BIBLIOGRAPHY

1. Klein HG; ed. Standards for blood banks and transfusion services. 17<sup>th</sup> ed. Bethesda: American Association of Blood Banks, 1996.
2. CFR 21: Part 640:4(e)(3).
3. Moroff G, Holme S, Keegan T, Heaton A: Storage of ADSOL-preserved red cells at 2.5 and 5.5 degrees C: comparable retention of invitro properties. Vox Sang 1990: 59:136-139.
4. Moroff G, Holme S, Heaton WA, Kevy S, Jacobson M, Popovsky M. Effect of an 8-hour holding period on in vivo and in vitro properties of red cells and factor VIII content of plasma after collection in a red cell additive system. Transfusion 1990 Nov-Dec; 30:828-832.
5. Wagner SJ, Robinette D, Nazario M, Moroff G. Bacteria levels in components prepared from deliberately inoculated whole blood held for 8 or 24 hours at 20 to 24

degrees C. Transfusion 1995 Nov-Dec;35(11):911-916.

6. Moore GL, Ledford ME, Merydith A. A micromodification of the Drabkin hemoglobin assay for measuring plasma hemoglobin in the range of 5 to 2000 mg/dl. Biochem Med 1981; 26:167-173.

7. Moroff G, Sohmer PR, Button LN. Proposed standardization of methods for determining the 24-hour survival of stored red cells. Transfusion 1984; 24:109-114.

8. Davey RJ. Red cell radiolabeling in transfusion medicine. In Davey RJ, and Wallace ME, eds. Diagnostic and Investigational Uses of Radiolabeled Blood Elements, Arlington VA: American Association of Blood Banks, 1987.

9. Ruddell JP, Lippert LE, Babcock JG, Hess JR. Effect of 24-hour storage at 25°C on the in vitro storage characteristics of CPDA-1 packed red cells. Transfusion 1998 May; 38:424-428.

10. Vengelen-Tyler V, ed. Technical manual. 12<sup>th</sup> ed. Bethesda: American Association of Blood Banks, 1996.

11. Kendrick DB. Blood program in world war II. Office of the Surgeon General, Department of the Army, Washington, DC, 1989.

12. Shields CE. Studies on stored blood. IV. Effects of temperature and mechanical agitation on blood with and without plasma. *Transfusion* 1970; 10:155-162.

13. Walker RH, ed. Technical manual. 10<sup>th</sup> ed. Arlington: American Association of Blood Banks, 1990.

14. Pick P, Fabijanic J. Temperature changes in donor blood under different storage conditions. *Transfusion* 1971; 11:213-215.

15. Widmann FK, ed. Technical manual, 9<sup>th</sup> ed. Arlington: American Association of Blood Banks, 1985.

## Figure Legends

Figure 1. Measures of A) supernatant glucose concentration, B) supernatant pH, C) RBC ATP concentration, and D) supernatant hemoglobin concentration. The three arms of the study are 1) continuous 4°C storage (—◆—), 2) warming to 25°C on day 14 (---■---), and 3) warming to 25°C on day 28 (--▲--). The decrease in pH corresponds to the consumption of glucose and both are accelerated by warming. RBC ATP concentration decreases more rapidly after warming, presumably because ATP synthesis is slower at reduced pH. RBC lysis measured as supernatant hemoglobin concentration increases with storage time but never reaches a value of 440 mg/dL equivalent to lysis of 1% of the cells.

Figure 2. Measures of A) RBC ATP concentration at the end of storage and B) single-label 24-hour RBC recovery in the individual donors. RBC ATP concentration at the end of storage is correlated with viability, but it has little discriminant value for choosing units that store well. The poor survival of RBCs from a few donors represent the greatest source of variability in this study.

Figure 3. The viability measured as the 24-hour in vivo RBC recovery using the  $^{99m}\text{Tc}/^{51}\text{Cr}$  double-label method did not vary under the different conditions of storage.

• Authors

Thomas J. Reid, MD, PhD,

Janiine G. Babcock, MD

Claudia P. Derse-Anthony, M Admin S, MT

Heather R. Hill, BA

Lloyd E. Lippert, SBB(ASCP), Ph.D.

John R. Hess, MD, all of Walter Reed Army Institute of Research, Washington, DC 20307-5100

Reprint requests to COL Hess

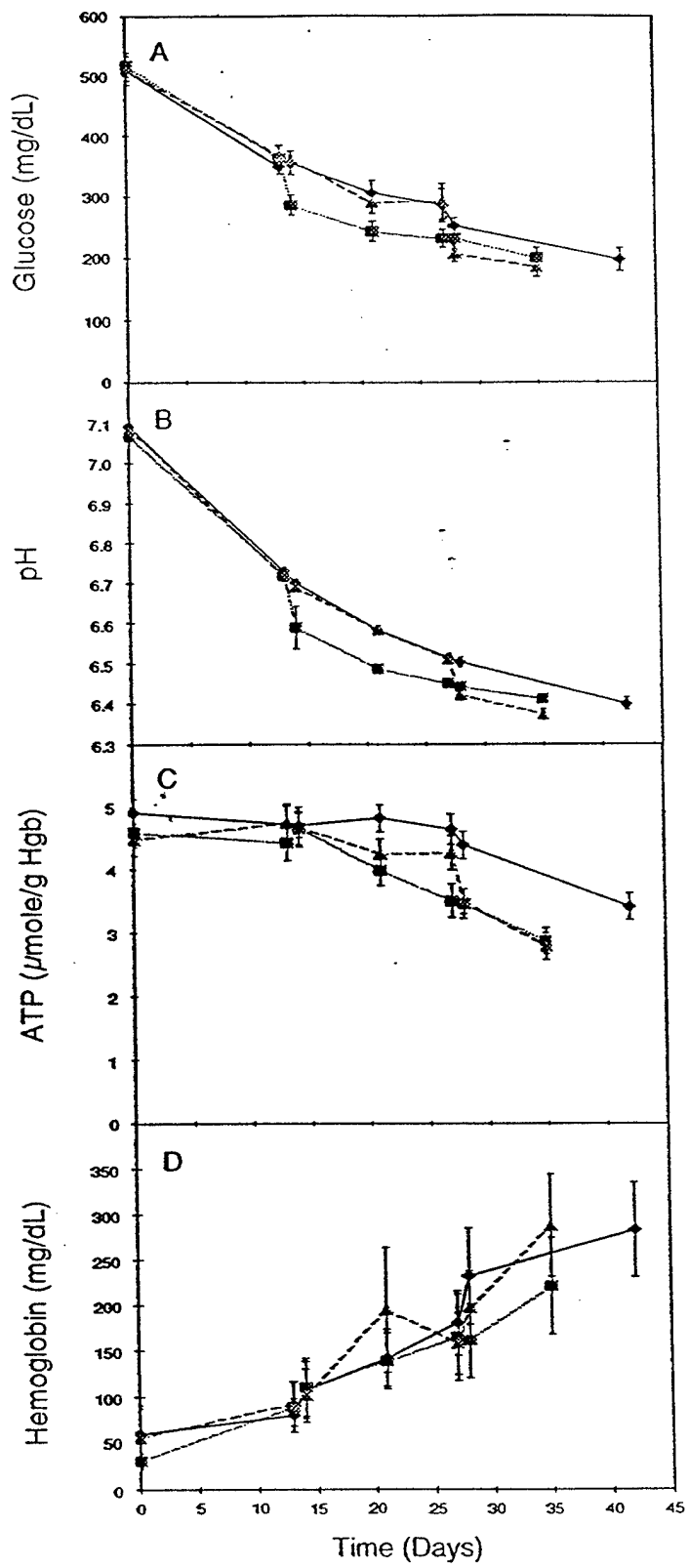

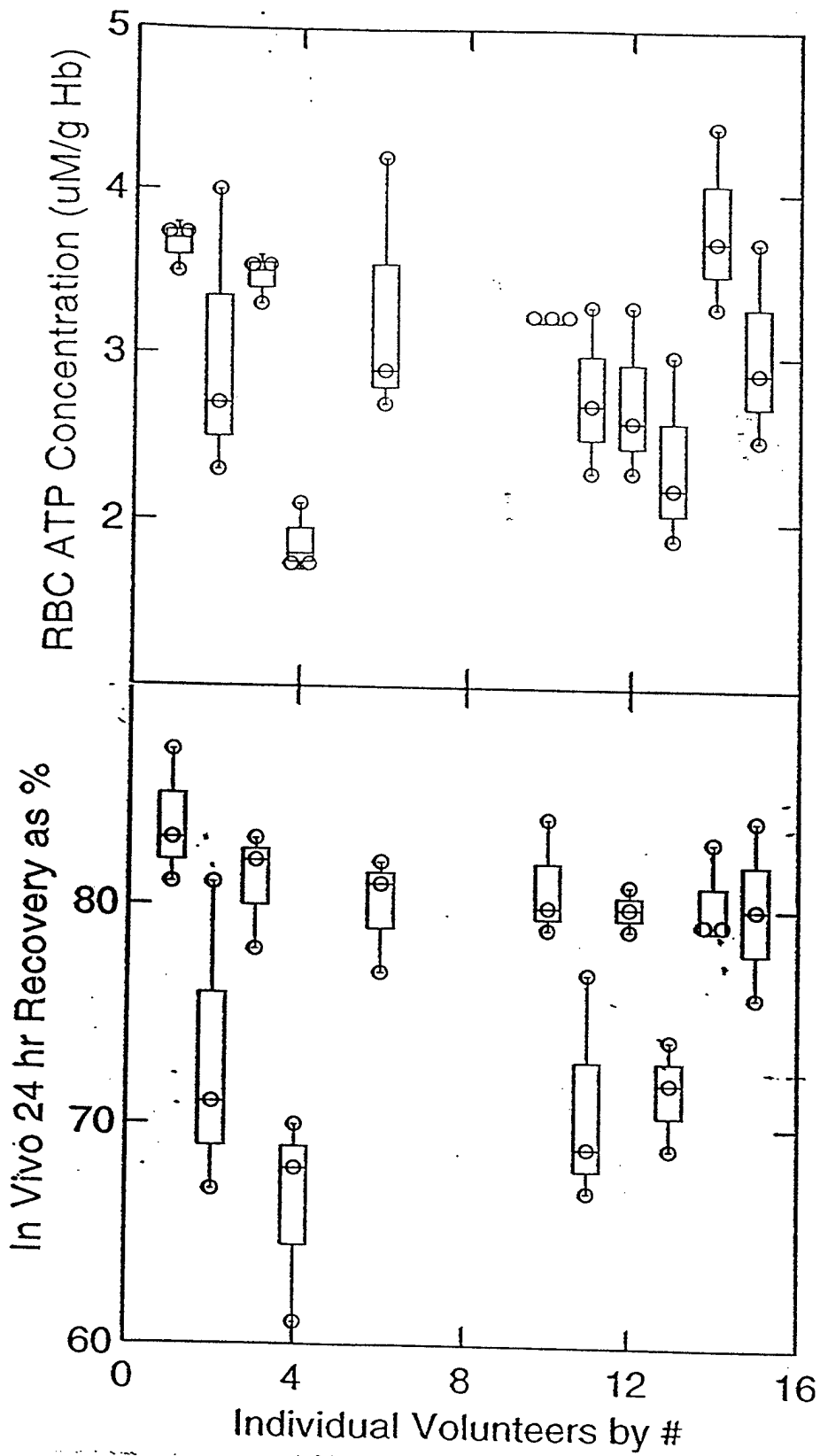

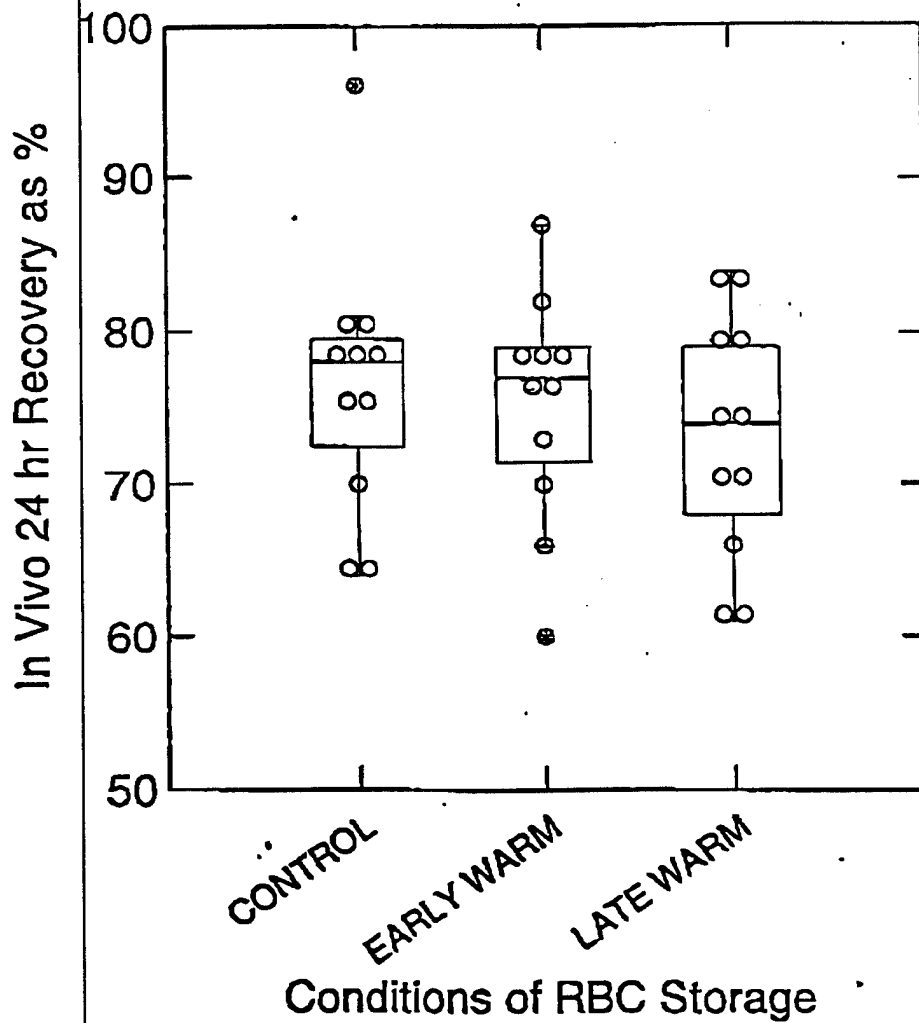

# Appendix 5

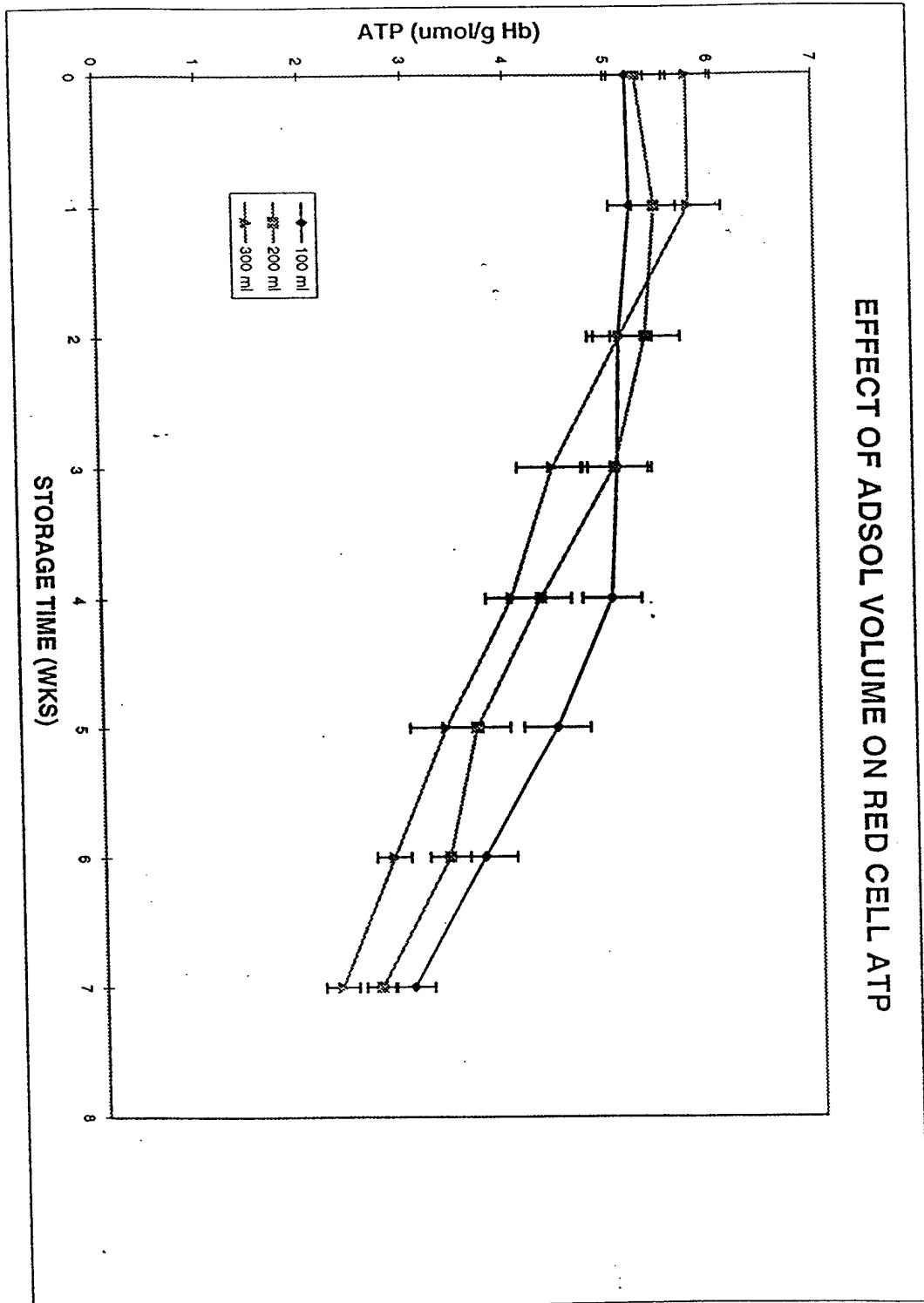

# Appendix 6

