

te technical note techn

Final Phase Runway Visual Range (RVR) /Automated Surface Observing System (ASOS) Interface Operational Test and Evaluation (OT&E) Report

William Benner
Thomas Carty
Michael McKinney

DISTRIBUTION STATEMENT A:
Approved for Public Release -
Distribution Unlimited

19981127 067

September 1998

DOT/FAA/CT-TN98/18

Document is on file at the William J. Hughes Technical Center
Library, Atlantic City International Airport, NJ 08405

**Reproduced From
Best Available Copy**



U.S. Department of Transportation
Federal Aviation Administration

William J. Hughes Technical Center
Atlantic City International Airport, NJ 08405

NOTICE

This document is disseminated under the sponsorship of the U.S. Department of Transportation in the interest of information exchange. The United States Government assumes no liability for the contents or use thereof.

The United States Government does not endorse products or manufacturers. Trade or manufacturers' names appear herein solely because they are considered essential to the objective of this report.

1. Report No. DOT/FAA/CT-TN98/18		2. Government Accession No.		3. Recipient's Catalog No.	
4. Title and Subtitle Final Phase Runway Visual Range (RVR)/Automated Surface Observing System (ASOS) Interface Operational Test and Evaluation (OT&E) Report				5. Report Date September 1998	
				6. Performing Organization Code ACT-320	
7. Author(s) William Benner, Thomas Carty, Michael McKinney; Michael Jones, Raytheon Service Co.				8. Performing Organization Report No. DOT/FAA/CT-TN98/18	
9. Performing Organization Name and Address U.S. Department of Transportation Federal Aviation Administration William J. Hughes Technical Center Atlantic City International Airport, NJ 08405				10. Work Unit No. (TRAIS)	
				11. Contract or Grant No.	
				13. Type of Report and Period Covered Technical Note	
				14. Sponsoring Agency Code	
12. Sponsoring Agency Name and Address U.S. Department of Transportation Federal Aviation Administration William J. Hughes Technical Center Atlantic City International Airport, NJ 08405					
15. Supplementary Notes This effort was performed in cooperation with William J. Hughes Technical Center and project personnel from Raytheon Service Co. in Pleasantville, New Jersey.					
16. Abstract This report summarizes results of Operational Test and Evaluation (OT&E) performed on the Final Phase Runway Visual Range (RVR) Automated Surface Observing System (ASOS) Interface. Testing was conducted from June 23 through 27, 1997, at Memphis International Airport (MEM). This test effort follows two OT&E sessions for the Interim Phase RVR/ASOS Interface at MEM during October 1996, and January 1997. Refer to document DOT/FAA/CT-TN97/14 for results of OT&E on the Interim RVR/ASOS Interface. The purpose of OT&E was to verify adherence to requirements as stated in Interface Control Document (ICD) 50-SANW-1-0050 and determine the operational effectiveness and suitability of the interface within the National Airspace System (NAS). OT&E activities resulted in the observance of 20 problems documented as Test Trouble Reports (TTR). Of the identified problems, 3 related to New Generation RVR system operation, 7 related to ASOS performance, and 10 were associated with RVR installation and instruction documentation. Initial analysis indicates problems relating to RVR system operation will have a minimal, if any, impact on New Generation RVR/ASOS Interface performance. OT&E resulted in no problems directly relating to New Generation RVR/ASOS Interface operation. As a result, ACT-320 recommends deployment of the interface after the successful completion and passing of remote maintenance monitoring tests.					
17. Key Words New Generation RVR/ASOS Interface Simulated RVR to ASOS Test Date Communication Failure Test Operational Procedure Test			18. Distribution Statement Document is on file at the Technical Center Library, Atlantic City International Airport, NJ 08405		
19. Security Classif. (of this report) Unclassified		20. Security Classif. (of this page) Unclassified		21. No. of Pages 88	22. Price

TABLE OF CONTENTS

	Page
EXECUTIVE SUMMARY	v
1. INTRODUCTION	1
1.1 Purpose	1
1.2 Scope Of Report	1
1.3 Background	1
2. REFERENCE DOCUMENTS	3
2.1 FAA Documents	3
2.2 National Weather Service Document	3
2.3 Other Documents	4
3. SYSTEM DESCRIPTION	4
3.1 Mission Review	4
3.2 Test System Configuration	5
3.3 Interfaces	9
4. TEST AND EVALUATION DESCRIPTION	10
4.1 Test Schedule and Location	10
4.2 Participants	10
4.3 Test and Specialized Equipment	11
4.4 Test Objectives	12
4.5 Test Descriptions	12
4.6 Data Collection and Analysis Methods	23
5. OPERATIONAL TEST AND EVALUATION RESULTS	24
5.1 Simulated RVR to ASOS Test Results	24
5.2 Operational Procedure Test Part 1 Results	25
5.3 Operational Procedure Test Part 2 Results	28
5.4 Data Communication Failure Test Results	31
5.5 Extended Operation And Evaluation Test Results	33
5.6 New Generation RVR/ASOS Interface Installation Results	33
5.7 Operational Test and Evaluation Limitations	34
6. CONCLUSIONS	34
7. RECOMMENDATIONS	35
8. ACRONYMS	36
APPENDIX	

LIST OF ILLUSTRATIONS

Figure		Page
3.3.1-1	RVR/ASOS ADU	9
4.5.1.2-1	Simulated RVR To ASOS Test Setup	13
4.5.2.2.1-1	Operational Procedure Test Setup	20
4.5.3.2-1	Data Communication Failure Test Setup	22

LIST OF TABLES

Table		
1	New Generation RVR Configuration	5
2	ASOS Configuration	6
3	RVRMSG3.DAT SCRIPT	15
4	RVRMSG4.DAT SCRIPT	15
5	RVRMSG5.DAT SCRIPT	16
6	RVRMSG6.DAT SCRIPT	17
7	RVRMSG7.DAT SCRIPT	17
8	RVRMSG8.DAT SCRIPT	18
9	RVR Product Generation Settings	21
10	Operational Procedure Test Output	29

EXECUTIVE SUMMARY

This document summarizes results of Operational Test and Evaluation (OT&E) performed on the Final Phase New Generation Runway Visual Range (RVR)/Automated Surface Observing System (ASOS) Interface. Testing was conducted from June 23 through 27, 1997, at Memphis International Airport (MEM).

Although OT&E for the New Generation RVR system was completed and resulted in an initial commissioning during 1995, several planned interfaces including the RVR/ASOS Interface were not available for testing. Consequently, OT&E for the New Generation RVR/ASOS Interface was deferred.

The purpose of OT&E was to verify adherence to requirements as stated in Interface Control Document (ICD) 50-SANW-1-00050 and determine the operational effectiveness and suitability of the interface within the National Airspace System (NAS).

Final Phase OT&E activities resulted in the observance of 20 problems documented as Test Trouble Reports (TTRs). Of the identified problems, 3 related to New Generation RVR system operation, 7 related to ASOS performance, and 10 were associated with RVR installation and instruction documentation. None of the New Generation RVR problems directly impact performance of the New Generation RVR/ASOS Interface. As a result, ACT-320 recommends deployment after the successful completion of Remote Maintenance Monitoring (RMM) tests.

1. INTRODUCTION.

This report documents results of Operational Test and Evaluation (OT&E) performed on the Final Phase Runway Visual Range (RVR)/ Automated Surface Observing System Interface (ASOS). Testing was conducted from June 23 through 27, 1997, at Memphis International Airport (MEM). This report was developed in accordance with FAA-STD-024B and FAA-ORDER-1810.4B.

1.1 PURPOSE.

The purpose of this report is to discuss results of OT&E activities performed with the Final Phase New Generation RVR/ASOS Interface at MEM.

1.2 SCOPE OF REPORT.

This report focuses¹ on the following topics:

- a. New Generation RVR/ASOS Interface background information,
- b. Descriptions of the New Generation RVR and ASOS,
- c. OT&E problem summary,
- d. ACT-320 OT&E conclusions, and
- e. ACT-320 recommendations for problem resolution.

Descriptions of test and evaluation exercises are also provided.

1.3 BACKGROUND.

A brief discussion of the history and intended purpose for the New Generation RVR/ASOS Interface and ASOS are presented in the following subparagraphs.

¹It should be noted that results of Remote Maintenance Monitoring (RMM) tests with the Final RVR/ASOS Interface will be addressed in a separate report since the unavailability of a Maintenance Processor Subsystem at MEM prevented execution during the test session.

1.3.1 New Generation RVR/ASOS Interface.

The New Generation RVR/ASOS Interface is intended to automatically transfer RVR data to ASOS users such as airlines, pilots, and Flight Service Stations (FSS). Data output from the New Generation RVR/ASOS Interface is calculated for use with Long-Line RVR reporting from the ASOS². The interface is designed to eliminate the need for manual entry of RVR readings from strip chart recorders on predecessor RVR systems.

As discussed in the New Generation RVR Final OT&E Report DOT/FAA/CT-TN95/32-I, the unavailability of several planned system interfaces including the RVR/ASOS Interface, prevented testing of these components during initial OT&E. As a result, OT&E for the New Generation RVR/ASOS Interface was deferred.

The Final Phase interface consists of an Intelligent Communications Controller Card (ICC) with a built-in serial interface and custom software developed by Teledyne Controls, Inc. The Final Phase RVR/ASOS Interface will reside within the New Generation RVR Data Processing Unit, and automatically output data through an EIA-530 serial interface compatible with ASOS.

1.3.2 Automated Surface Observing System (ASOS).

The ASOS utilizes sensors located on the airfield to measure weather parameters such as wind speed/direction, ambient temperature, and precipitation. Deployment of ASOS has permitted automatic dissemination of Surface Aviation Observation (SAO) format messages to various users such as airlines, pilots, and FSSs. Although the SAO could contain RVR products within the "remarks" section, the lack of an automated interface between the RVR system and ASOS resulted in the need for manual entry of RVR products into the SAO. The New Generation RVR/ASOS interface will eliminate the need for manual entry of RVR products by providing a reliable automated interface for transferring data to ASOS.

As of July 1, 1996, RVR products disseminated through ASOS are reported as part of the METAR (Aviation Routine Weather Report) message, and the SAO message is no longer used. This results in RVR products residing in the main portion of the report instead of the remarks section.

² The Long-Line RVR reading is obtained from the ASOS and consists of the 10-minute average RVR reading calculated with runway light setting 5 from a designated touchdown Visibility Sensor (VS).

2. REFERENCE DOCUMENTS.

The following sections list Federal Aviation Administration (FAA), NWS, and related documents used in preparation for OT&E and this report.

2.1 FAA DOCUMENTS.

FAA Order 1810.4B	FAA NAS Test and Evaluation Policy, October 22, 1992.
FAA-STD-024B	Preparation of Test and Evaluation Documentation, August 22, 1994.
FAA-E-2772	New Generation Runway Visual Range System Specification, Amend.-4, April 1990.
NAS-IR-33109301	Interface Requirements Document, Runway Visual Range (RVR) with the Automated Surface Observing Systems (ASOS) March 21, 1990.
NAS-SS-1000	U.S. Department of Transportation Federal Aviation Administration Specification NAS System Specification Volume I, October 1992.
TEST PLAN	New Generation Runway Visual Range Automated Surface Observing System Interface OT&E Test Plan, October 16, 1996.
TEST PROCEDURES	New Generation Runway Visual Range Automated Surface Observing System Interface OT&E Test Procedures, June 6, 1997.

2.2 NATIONAL WEATHER SERVICE DOCUMENT.

50-SANW-1-00050	Appendix XII Interface Control Document (ICD) Runway Visual Range (RVR) System to Automated Surface Observing System (ASOS), May 30, 1991.
-----------------	--

2.3 OTHER DOCUMENTS.

EIA-STD-RS-232	Interface Between Data Terminal Equipment and Data Communication Equipment Employing Serial Binary Data Interchange, August 1969.
EIA-530	High Speed 25-Position Interface for Data Terminal Equipment and Data Circuit Equipment. Electronic Industries Association Standard 530, March 1987.
ANSI X3.28-1976	American National Standards Procedures for the Use of the Communication Control Characters of American National Standard Code for Information Interchange in Specified Data Communications Links. Approved December 17, 1975.

3. SYSTEM DESCRIPTION.

This section provides a mission review summary and a brief description of the MEM New Generation RVR and ASOS.

3.1 MISSION REVIEW.

The New Generation RVR system is designed to provide measurement of runway visibility at specific points along a precision runway. The system supports instrument landings during Category I, II, IIIa/b visibility conditions as defined in specification FAA-E-2772. To provide RVR data, the system determines the following parameters:

- a. Ambient light intensity,
- b. Atmospheric scattering coefficient, and
- c. Runway centerline/edge light intensity.

The system processes this data to output distances a pilot could expect to see along the departure or approach path of the runway. The New Generation RVR system is designed to decrease the maintenance load and installation difficulties associated with predecessor runway visual range systems. Future expansion capabilities will be easier and less costly.

3.2 TEST SYSTEM CONFIGURATION.

The Test System Configuration utilized an operational New Generation RVR and ASOS. The MEM New Generation RVR and ASOS were configured with the components identified in tables 1 and 2.

TABLE 1. NEW GENERATION RVR CONFIGURATION

COMPONENT	NO.	ADDITIONAL INFORMATION
Visibility Sensor	6	Located For 36L, 36C, 36R
Ambient Light Sensor	1	Located on Administration Building Roof
Runway Light Intensity Monitor	2	Located in Electrical Power Vault
Data Processing Unit	1	Configured with RVR/ASOS Interface;
Controller Display	11	Located in Tower Cab, TRACON, and Equipment Room
Software Components -Maintenance Processor Unit -Product Processing Unit A -Product Processing Unit B -VS SIE -ALS SIE -RLIM SIE -RVR/ASOS Interface -Controller Display	8	SOFTWARE VERSION ID 1101966050 1101966050 1101966050 1523952041 1523953043 0430944040 1017967010 4.3

TABLE 2. ASOS CONFIGURATION

COMPONENT	NO.	ADDITIONAL INFORMATION
Acquisition Control Unit	1	Software Version 2.47
Pressure Sensors	3	
Operator Interface Device	2	Located In ATCT
Video Display Unit	1	Located In Contract Weather Office
Printer	1	Located In ATCT
Data Collection Package #1 -Present Weather Sensor (LEDWI) -Temperature Dewpoint Sensor -Wind Speed & Direction Sensor Liquid Precipitation Sensor	1	Centerfield Airport Location
Data Collection Package #2 -Visibility Sensor [Primary] -Ceilometer (CHI) [Primary]	1	Runway Touchdown Zone
Data Collection Package #3 -Visibility Sensor [Backup] -Ceilometer (CHI) [Backup]	1	Runway Touchdown Zone

3.2.1 System Descriptions.

The following subparagraphs provide additional general descriptions of the New Generation RVR and ASOS.

3.2.1.1 New Generation RVR Description.

New Generation RVR products are calculated by the system's DPU using measurements from ambient light, visibility, and current loop sensors. Calculated RVR products are displayed in real-time in the Air Traffic Control Tower (ATCT) tower cab. A brief description of the sensors and other major RVR components are discussed in the following paragraphs.

3.2.1.1.1 Ambient Light Sensor.

The Ambient Light Sensor (ALS) is a single unit sensor used to measure the amount of ambient or background light. It is aimed at an angle of 6° above the north horizon. The ALS is typically mounted on the outside of the ATCT to ensure an unobstructed view.

3.2.1.1.2 Visibility Sensor.

The New Generation RVR VS utilizes two sensor heads, an infrared light transmitter, and an infrared light receiver. The VS is installed alongside the runway at as many locations as required by the runway's Instrument Flight Rule (IFR) rating (e.g., three for Category IIIb, one for Category I). The VS transmitter and receiver are aimed downward at an angle of 19°. The intersection of the receiver and transmitter beams forms a "sample volume" in space. Infrared light from the transmitter entering this volume will be reflected into the receiver by particles present in the air. The measurement of the reflected light is used to determine the atmospheric extinction coefficient.

3.2.1.1.3 Runway Light Intensity Monitor.

The Runway Light Intensity Monitor (RLIM) is typically located in the power vault for the runway lights. The RLIM is used to monitor the runway centerline/edge light intensity. The RLIM makes use of current loop sensors to measure the amount of current being supplied to the runway lights. The greater the current, the higher the runway light intensity. The current measurement is translated into a runway light setting with values of 0, 1, 2, 3, 4, or 5. The value 0 represents runway lights turned off. The value 5 represents the highest runway light intensity.

3.2.1.1.4 Data Processing Unit.

The Data Processing Unit (DPU) is a redundant, highly self-testable microcomputer that executes the data gathering, processing, and archiving functions for the RVR system. The New Generation RVR/ASOS Interface as well as several other interfaces (e.g., external user, maintenance processor subsystem, etc.) are contained within the DPU. The DPU is typically located in the ATCT.

3.2.1.1.5 Controller Display.

The Controller Display (CD) allows air traffic controllers to view RVR products for specific runway(s) selected. The CD is typically located in the tower cab of the ATCT and in the Terminal Radar Control (TRACON) facility.

3.2.1.2 ASOS Description.

The ASOS collects surface weather data to prepare its SAO/Aviation Routine Weather Report (METAR). The ASOS system senses and measures the following:

- a. Wind speed/direction;
- b. Ambient temperature;
- c. Dewpoint temperature;
- d. Atmospheric pressure;
- e. Visibility;
- f. Cloud layer height--reported as Sky Condition;
- g. Precipitation Type and Intensity--reported as Present Weather;
- h. Liquid Precipitation Accumulation; and
- i. Freezing rain occurrence.

ASOS collects RVR information through a serial interface port residing in its Acquisition Control Unit (ACU). The ASOS can also transmit weather observations (i.e., SAOs or METAR format) once a minute to the Automated Weather Observing System (AWOS) Data Acquisition System (ADAS) in response to polls from ADAS.

The weather observation is then distributed for use by the FAA, National Weather Service (NWS), airlines, and pilots.

3.3 INTERFACES.

The following paragraphs provide an introduction to New Generation RVR DPU interfaces used during RVR/ASOS Interface OT&E. The interfaces discussed include those required for the Interim and Final Phase efforts, as well as locations containing remote monitoring functions.

3.3.1 New Generation RVR/ASOS Interface.

The New Generation RVR/ASOS Interface consists of an ICCC which resides within the New Generation RVR DPU. The controller card is designed to automatically output ASOS Application Data Unit (ADUs) messages every 30 seconds and contains an EIA-530 interface configured as Data Terminal Equipment.

The New Generation RVR/ASOS Interface utilizes simplex transmission of ADUs to ASOS consisting of the information shown in figure 3.3.1-1. The ADU is transferred to the ASOS ACU at a rate of twice per minute with the following communication protocol: 2400 bits per second (bps), Even parity, 7 Data bits, and 1 Stop bit.

Time Stamp	Runway ID	Runway Sub ID	RVR Product
------------	-----------	---------------	-------------

FIGURE 3.3.1-1. RVR/ASOS ADU

3.3.2 Maintenance Processor Subsystem.

The Maintenance Processor Subsystem (MPS) interface allows the New Generation RVR to be controlled and monitored remotely. This includes all parameters associated with the RVR/ASOS Interface. The New Generation RVR MPS interface resides on the DPU and requires connection to a Tandem mainframe computer system for operation. Due to the unavailability of a connection between the New Generation RVR and the Tandem computer, testing with the MPS interface was deferred.

3.3.3 Maintenance Data Terminal (MDT).

The MDT enables local control and monitoring of New Generation RVR components. The interface consists of a standard RS-232 interface and menu driven software residing within the RVR component containing the interface. Each major component; e.g.,

DPU, Sensor Interface Electronics (SIE), contains a MDT interface. New Generation RVR/ASOS Interface OT&E required the use of DPU and SIE MDT interfaces to monitor and control various RVR components and parameters.

3.3.4 Controller Display (CD).

The CD interface resides on the DPU and enables one-way transmission of RVR products to CDs located in the Air Traffic Control (ATC) Tower Cab, TRACON, and ATC equipment areas. For CDs located near the DPU, an RS-485 interface is typically used and allows up to 29 CDs to be connected to the same interface with a maximum distance limitation of 2000 feet. For remotely monitored CDs, the DPU RS-232 interface is used for RVR product transfer. MEM OT&E activities utilized locally monitored CDs on the RS-485 interface.

4. TEST AND EVALUATION DESCRIPTION.

This section describes participants involved in OT&E test sessions, equipment required for testing, and RVR/ASOS Interface OT&E tests.

4.1 TEST SCHEDULE AND LOCATION.

Final Phase RVR/ASOS Interface tests were conducted from June 23 through 27, 1997, at MEM. Installation exercises in preparation for OT&E were also conducted at the William J. Hughes Technical Center on June 18 and 19, 1997.

As noted in the New Generation RVR/ASOS Interface Test Plan dated October 16, 1996, RMM tests with the MPS Interface were planned as part of the OT&E effort. However, since the New Generation RVR System was not configured with a connection to the MPS, RMM tests were deferred to another time and location. At the conclusion of OT&E activities, MPS OT&E was scheduled to be conducted during August 1997, at Los Angeles International Airport.

4.2 PARTICIPANTS.

Participants and their respective roles during OT&E included the following organizations:

- a. National Weather Service (NWS). NWS representatives coordinated OT&E through obtaining approvals from local and regional representatives. The NWS assisted in the conduct of OT&E by providing technical support, test equipment, and operators for the ASOS. NWS representatives included personnel from the ASOS program office and National Oceanic Atmospheric Association (NOAA).
- b. FAA Aeronautical Center. The FAA Aeronautical Center provided technical support for the New Generation RVR System during testing, assisted in installation activities, and assisted with test conduct.
- c. Teledyne Controls Inc. Teledyne Controls, Inc. representatives designed and developed the RVR/ASOS Interface. During OT&E, Teledyne provided technical support for the New Generation RVR System. Teledyne representatives also assisted in installation activities and resolution of test procedure issues.
- d. RVR Program Office. The RVR Program Office coordinated the OT&E effort by obtaining approvals from regional and local FAA representatives. The Program Office also assisted in the resolution of test procedure issues and test conduct.
- e. William J. Hughes Technical Center. William J. Hughes Technical Center representatives assisted in installation activities, resolved coordination issues with MEM airport personnel, conducted OT&E tests, and functioned as Test Director.
- f. Memphis Airport. MEM representatives provided official on-site support for access to New Generation RVR and ASOS equipment and related facilities. Memphis Airport personnel also provided on-site resources such as printers, terminals, and conference areas required for testing.

4.3 TEST AND SPECIALIZED EQUIPMENT.

The following equipment test and analysis tools were used during OT&E testing:

- a. PC-based RVR simulator,
- b. Protocol analyzer, and
- c. Data Communication Fault Simulator (DCFS).

4.3.1 PC-based RVR Simulator (ASOS ADU Generator).

To simulate New Generation RVR/ASOS Interface output, a PC-based RVR simulator or ASOS ADU generator was used. The simulator operated by using script files consisting of preprogrammed RVR products and runway identifiers. The simulator's data transmission rate was configured to match the New Generation RVR/ASOS Interface of 2x/minute.

4.3.2 Protocol Analyzer.

To capture all data transmitted to ASOS and verify status of the communications link, protocol analyzers were used during all OT&E tests. The NETLENS 3000 analyzer was used to accomplish these tasks.

4.3.3 Data Communication Fault Simulator.

Data communication faults and errors between the Final Phase Interface and ASOS were created through the use of the PC data communication tool "TERMINAL". The software tool was designed to simulate communication problems including parity mismatch and invalid Block Check Codes (BCC) during data transmissions between the New Generation RVR/ASOS Interface and ASOS.

4.4 TEST OBJECTIVES.

In general, OT&E tests were designed to verify whether New Generation RVR/ASOS Interface operation was in compliance with specifications 50-SANW-00050 and FAA-E-2772. Testing was also intended to determine if performance degradation existed on the New Generation RVR and ASOS as a result of the New Generation RVR/ASOS Interface operation. Specific objectives for each test category are discussed in the Test Descriptions, section 4.5.

4.5 TEST DESCRIPTIONS.

Four test categories were performed on the New Generation RVR and ASOS. The tests are identified as follows and described further in the following subparagraphs:

- a. Simulated RVR to ASOS Test,
- b. Operational Procedure Test,
- c. Data Communication Failure Test, and
- d. Extended Operation and Evaluation Test.

4.5.1 Simulated RVR to ASOS Test.

The Simulated RVR to ASOS Test was the first test performed during OT&E. This test featured use of a PC-based ASOS ADU generator which replicated the New Generation RVR/ASOS Interface functionally by sending ASOS ADUs to the ASOS ACU. The ADU generator was programmed to transmit a range of RVR products; e.g., 100 feet to 6500 feet, usually with a different product transmitted each minute, and function continuously without operator intervention.

ADU generator RVR products were transmitted at the same rate, i.e., 2x/minute, as from the New Generation RVR/ASOS Interface. Non-numeric and illegal RVR products such as "FFF", " ", and "(+" were also transmitted from the ADU generator. The ASOS was configured to display RVR products as they were received. The test focused on verifying whether RVR products displayed on the ASOS display matched transmitted ADU products. The ADU generator transmitted RVR products for approximately 3 hours under control of several script files. Paragraph 4.5.1.2.1 discusses the intent of each script file used during testing.

4.5.1.1 Simulated RVR to ASOS Test Objectives.

The objective of the Simulated RVR to ASOS Test was to verify proper operation of ASOS RVR functions implemented in software version 2.47.

4.5.1.2 Simulated RVR to ASOS Test Setup.

The ASOS ADU generator was connected to ASOS as shown in figure 4.5.1.2-1. The ASOS was initialized with its operational software during test setup.

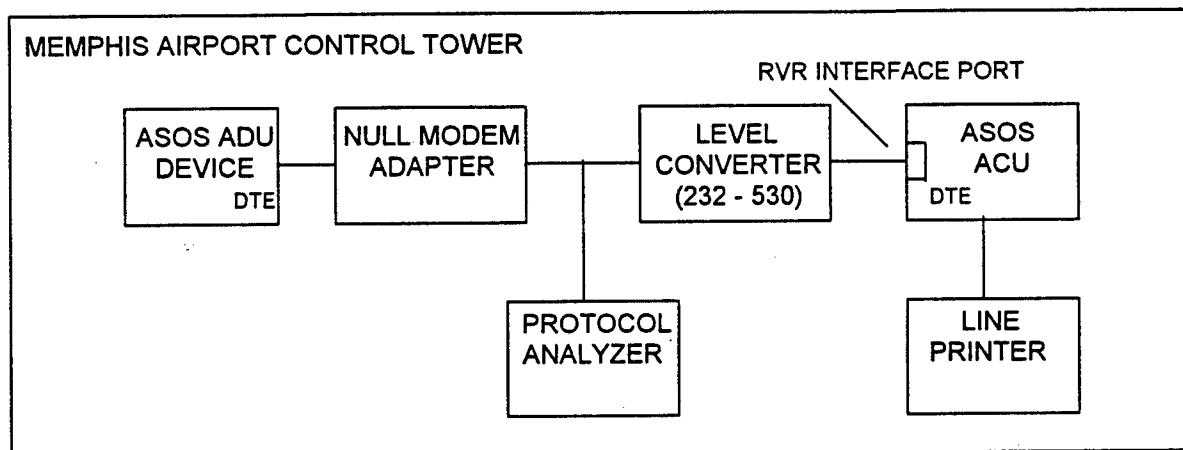

FIGURE 4.5.1.2-1. SIMULATED RVR TO ASOS TEST SETUP

4.5.1.2.1 ADU GENERATOR SCRIPT FILES.

Script files identified in paragraphs 4.5.1.2.1.1 through 4.5.1.2.1.5 were used to output pre-programmed RVR products during the Simulated RVR to ASOS Test. File contents are listed in tables 3 through 8. A brief discussion of the script file precedes each table.

For each table, the row labeled with RWYID represents the runway identifier included in each RVR product transmitted. The PROD# column identifies the order of the product transmitted. The column labeled VALUE contains the actual RVR product transmitted. The ADU generator was configured to repeat the script file output sequence immediately after transmission of the last product in the file. For example, in table 3, PROD# 1 was transmitted after PROD# 60.

4.5.1.2.1.1 RVRMSG3.DAT.

RVRMSG3.DAT was designed specifically to verify whether ASOS "specials" or detection of significant weather parameter changes, were properly generated in response to RVR product variations.

Since ASOS processing software was designed to generate an RVR special when the RVR product crossed 2400 feet (in both directions), typical RVR product values on each side of the 2400-foot threshold were included in RVRMSG3.DAT to test this function. An additional requirement for the ASOS special was that the RVR product must remain above/below the threshold for at least 10 minutes. This was accounted for in the RVRMSG3.DAT file by including 10 minutes or at least 20 RVR product readings above and below 2400 feet. FFF products were included at the end of the script file sequence to verify whether the occurrence of a series of non-numeric products would prevent proper detection and notification of an RVR weather special. To determine if an RVR special was generated when RVR readings increased past the 2400-foot threshold, the file contained an RVR product sequence where a series of 2200-foot RVR readings (represented by the number 22) changed to a series of 2600-foot readings (represented by the number 26).

TABLE 3. RVRMSG3.DAT SCRIPT

RWYID	02L								
PROD#	VALUE	PROD#	VALUE	PROD#	VALUE	PROD#	VALUE	PROD#	VALUE
1	22	13	22	25	26	37	26	49	FFF
2	22	14	22	26	26	38	26	50	FFF
3	22	15	22	27	26	39	26	51	FFF
4	22	16	22	28	26	40	26	52	FFF
5	22	17	22	29	26	41	FFF	53	FFF
6	22	18	22	30	26	42	FFF	54	FFF
7	22	19	22	31	26	43	FFF	55	FFF
8	22	20	22	32	26	44	FFF	56	FFF
9	22	21	26	33	26	45	FFF	57	FFF
10	22	22	26	34	26	46	FFF	58	FFF
11	22	23	26	35	26	47	FFF	59	FFF
12	22	24	26	36	26	48	FFF	60	FFF

4.5.1.2.1.2 RVRMSG4.DAT.

RVRMSG4.DAT was designed with the same general intent as RVRMSG3.DAT, but was specifically intended to verify generation of an ASOS RVR special in response to a decrease in RVR readings through the 2400-foot threshold. As a result, the RVR product sequence contained the transition from a series of 2600-foot products to a series of 2200-foot products.

TABLE 4. RVRMSG4.DAT SCRIPT

RWYID	02L								
PROD#	VALUE	PROD#	VALUE	PROD#	VALUE	PROD#	VALUE	PROD#	VALUE
1	26	13	26	25	22	37	22	49	FFF
2	26	14	26	26	22	38	22	50	FFF
3	26	15	26	27	22	39	22	51	FFF
4	26	16	26	28	22	40	22	52	FFF
5	26	17	26	29	22	41	FFF	53	FFF
6	26	18	26	30	22	42	FFF	54	FFF
7	26	19	26	31	22	43	FFF	55	FFF
8	26	20	26	32	22	44	FFF	56	FFF
9	26	21	22	33	22	45	FFF	57	FFF
10	26	22	22	34	22	46	FFF	58	FFF
11	26	23	22	35	22	47	FFF	59	FFF
12	26	24	22	36	22	48	FFF	60	FFF

4.5.1.2.1.3 RVRMSG5.DAT.

RVRMSG5.DAT was intended to verify proper ASOS reception and display of non-numeric RVR products such as " ", FFF, and 60+. Additionally, the file was configured to verify generation of an RVR special by including a transition from products below and above 2400 feet. This file was also intended to verify proper reception and display of a runway identifier, "36", without letter designation, i.e., L, R, or C.

TABLE 5. RVRMSG5.DAT SCRIPT

RWYID	36						
PROD#	VALUE	PROD#	VALUE	PROD#	VALUE	PROD#	VALUE
1	10	13	16	25	FFF	37	60+
2	02	14	18	26	60+	38	60+
3	03	15	18	27	60+	39	60+
4	03	16	22	28	60+	40	
5	04	17	22	29	60+	41	
6	04	18	22	30	60+	42	
7	10	19		31	60+	43	02
8	10	20		32	60+	44	50
9	10	21		33	60+	45	50
10	14	22		34	60+	46	55
11	14	23	FFF	35	60+	47	57
12	16	23	FFF	35	60+	47	57

4.5.1.2.1.4 RVRMSG6.DAT.

Similar to the RVRMSG3.DAT and RVRMSG4.DAT files, RVRMSG6.DAT was intended to verify proper performance of RVR specials generated on ASOS. RVRMSG6.DAT was configured with RVR product transitions through 2400 feet without having 10 minutes of RVR product data below/above 2400 feet. This configuration was specifically designed to verify the ASOS RVR requirement of having 10 minutes of RVR data below/above the threshold before generating the weather special.

TABLE 6. RVRMSG6.DAT SCRIPT

RWYID	36
PROD#	VALUE
1	22
2	22
3	22
4	
5	
6	
7	
8	26+
9	26+
10	26+

4.5.1.2.1.5 RVRMSG7.DAT.

The RVRMSG7.DAT file was designed to verify whether the entire range of RVR products would be properly displayed on ASOS and verify proper generation of RVR-related specials. For this file a series of RVR products different from the previous files were used. For RVR products below the 2400-foot threshold, the file was configured to allow a different RVR product to be transmitted each minute. For products above the 2400-foot threshold, the same product was transmitted for each minute until the final 2 minutes.

TABLE 7. RVRMSG7.DAT SCRIPT

RWYID	36L								
PROD#	VALUE	PROD#	VALUE	PROD#	VALUE	PROD#	VALUE	PROD#	VALUE
1	10	11	10	21	60+	31	60+	41	57
2	10	12	10	22	60+	32	60+	42	57
3	02	13	14	23	60+	33	60+		
4	02	14	14	24	60+	34	60+		
5	03	15	16	25	60+	35	60+		
6	03	16	16	26	60+	36	60+		
7	04	17	18	27	60+	37	60+		
8	04	18	18	28	60+	38	60+		
9	10	19	22	29	60+	39	50		
10	10	20	22	30	60+	40	50		

4.5.1.2.2 RVRMSG8.DAT.

The RVRMSG8.DAT file was designed to verify how properly formatted, and non-numeric RVR products would be accounted for on ASOS display screens. To accomplish this, RVRMSG8.DAT contained a series of legal and typical RVR products followed by instances of non-numeric products not in accordance with the RVR/ASOS ICD.

TABLE 8. RVRMSG8.DAT SCRIPT

RWYID	36L								
PROD#	VALUE	PROD#	VALUE	PROD#	VALUE	PROD#	VALUE	PROD#	VALUE
1	01	7	04	13	07	19	(+	41	60+
2	01	8	04	14	07	20	(+	42	60+
3	02	9	05	15	08	21	(+		
4	02	10	05	16	08	22	(+		
5	03	11	06	17	(+	23	60+		
6	03	12	06	18	(+	24	60+		

4.5.2 Operational Procedure Test.

The Operational Procedure Test consisted of two parts whereby typical and atypical operating system tasks were performed on the New Generation RVR System and ASOS. Paragraphs 4.5.2.1 and 4.5.2.2 provide further descriptions of the conducted tests.

4.5.2.1 Operational Procedure Test Part 1.

Operational Procedure Test Part 1 consisted of performing a subset of system tasks on the New Generation RVR and ASOS such as restarts, maintenance, configuration, and fault diagnosis. While these system tasks were performed, proper operation of non-RVR/ASOS related components, the RVR/ASOS Interface and ASOS were monitored for performance degradation and anomalies. The following categories of system tasks were performed during OT&E:

- a. Component restart/reset. For the New Generation RVR system, each sensor type i.e., VS, ALS, RLIM, the DPU, and main processing units were restarted via MDT control. For ASOS, the ACU was restarted with hardware and software initialization procedures.
- b. System restart. Via the New Generation RVR MDT, system restarts were initiated for New Generation RVR hardware and software. System reinitialization was also performed on ASOS.

- c. Maintenance. The New Generation RVR system was configured for local control and sensor calibration was performed. Additionally, MDT parameter display screens were exercised and examined for each sensor and the DPU. For ASOS, maintenance as described in the Site Technical and Software Users manual was performed.
- d. Fault diagnosis. Fault diagnostic tests were performed for each sensor and the New Generation RVR DPU. Results were examined for accuracy and completion. A related set of fault diagnosis procedures as described in the Site Technical and Software Users manual was performed on the ASOS.

4.5.2.2 Operational Procedure Test Part 1 Objectives.

The objective for Part 1 of the Operational Procedure Test was to verify proper operation of New Generation and ASOS system tasks such as described in section 4.5.2.1. Additionally, to confirm proper operation of the New Generation RVR/ASOS Interface during execution of system tasks.

4.5.2.2.1 Operational Procedure Test Part 1 Setup.

Data collection devices, test equipment, and the RVR/ASOS interface were connected as shown in figure 4.5.2.2.1-1.

4.5.2.3 Operational Procedure Test Part 2.

Operational Procedure Test Part 2 consisted of manipulating RVR sensor measurements on the VS, ALS, and RLIM to generate various RVR products within the ASOS ADU from the New Generation RVR/ASOS Interface. Proper calculation of the RVR product was confirmed with stand-alone RVR calculation software and agreement between the transmitted ASOS ADU and the RVR product displayed on ASOS was confirmed for each transmitted product.

New Generation RVR VS measurements were manipulated with the aid of the calibration plate and foam plug. New Generation RVR ALS and RLIM measurements were manipulated by manually entering ALS and RLIM values via the MDT. Table 9 identifies the ambient light and runway light settings used as well as the expected RVR CD reading and ASOS reading.

4.5.2.3.1 Operational Procedure Test Part 2 Objectives.

The primary objective for Operational Procedure Test Part 2 was to verify proper formation and transmission of ASOS ADUs from the New Generation RVR/ASOS Interface after manipulation of RVR

sensors. The test was also intended to confirm whether the transmitted ASOS ADU matched RVR products on all applicable ASOS display screens.

4.5.2.3.2 Operational Procedure Test Part 2 Setup.

Test setup for Operational Procedure Test Part 2 remained as shown in figure 4.5.2.2.1-1.

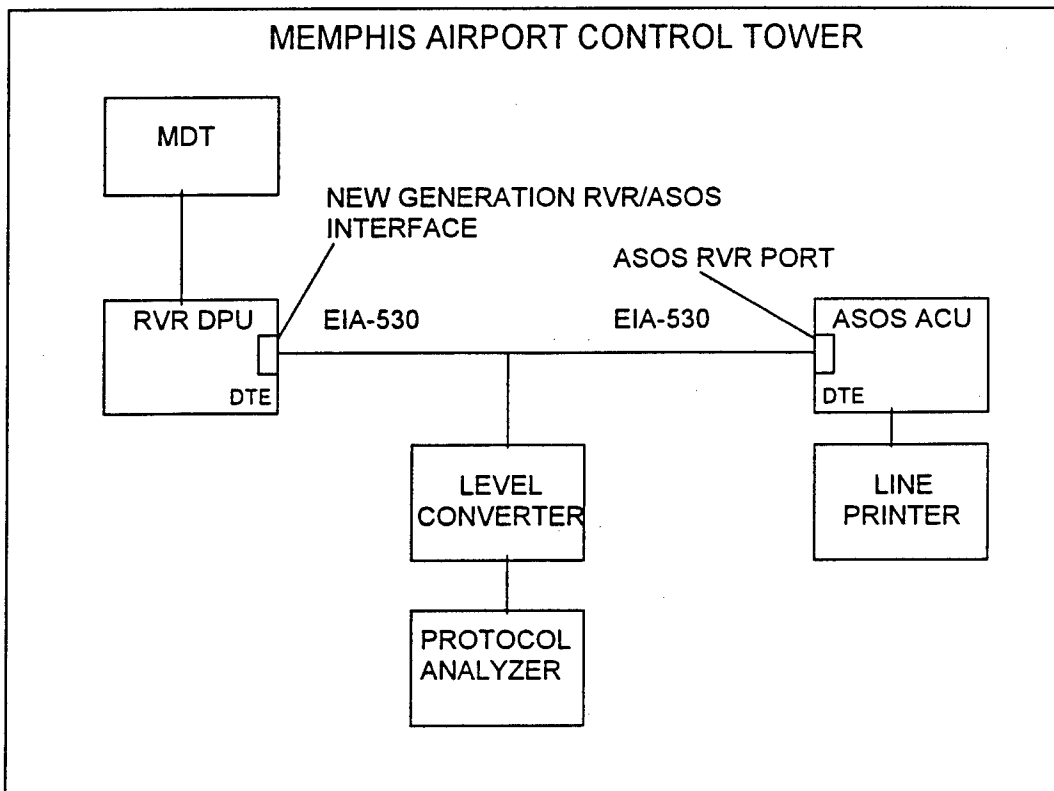

FIGURE 4.5.2.2.1-1. OPERATIONAL PROCEDURE TEST SETUP

TABLE 9. RVR PRODUCT GENERATION SETTINGS

ALS (ft-lamberts)	RLIM EDGE/CENTER SETTING	VS EXTINCTION COEFFICIENT (km^{-1})	RVR PRODUCT (ft)	RVR @ASOS
2000	0	w/ cal plate hi	100	100
2000	3	w/ cal plate lo	200	200
2000	5	on field site	computed	-
2000	5	w/ cal plate lo	300	300
2000	5	w/ plug	6500	6500
2000	5	sensor fail	FFF	FFF
6000	0	w/ cal plate hi	100	100
6000	3	w/ cal plate lo	200	200
6000	5	On field site	computed	-
6000	5	w/ cal plate lo	300	300
6000	5	w/ plug	6500	6500
6000	5	Sensor fail	FFF	FFF
12000	0	w/ cal plate hi	100	100
12000	3	w/ cal plate lo	200	200
12000	5	on field site	computed	-
12000	5	w/ cal plate lo	300	300
12000	5	w/ plug	6500	6500
12000	5	sensor fail	FFF	FFF

4.5.3 Data Communication Failure Test.

The Data Communication Failure Test featured a simulation of various communication problems that could occur under operational conditions with the New Generation RVR/ASOS Interface and ASOS. Simulated communication problems included: erroneous block check codes, parity errors, baud rate conflicts, and cable disconnect. New Generation RVR/ASOS Interface and ASOS performance were monitored during the existence of the communication problem as well as recovery from the communication problem.

4.5.3.1 Data Communication Failure Test Objectives.

The Data Communication Failure Test objective was to determine whether the New Generation RVR/ASOS Interface and ASOS could properly recover and handle communication errors that may occur during operation. This included detection and notification of communication problems as well as notification of the removal of a communication problem.

4.5.3.2 Data Communication Failure Test Setup.

A PC-based Data Communication Fault Simulator was connected to ASOS as shown in figure 4.5.3.2-1.

4.5.4 Extended Operation and Evaluation Test.

The Extended Operation and Evaluation Test consisted of configuring the New Generation RVR and ASOS to normal operating modes and allowing each system to function without operator intervention. Performance of the New Generation RVR/ASOS Interface was then remotely monitored during naturally occurring weather conditions and maintenance for an extended period.

4.5.4.1 Extended Operation and Evaluation Test Objectives.

The objective of the Extended Operation and Evaluation Test was to verify proper performance of the New Generation RVR/ASOS Interface for an extended time period; e.g., at least 2 weeks, at an operational site.

4.5.4.2 Extended Operation and Evaluation Test Setup.

Test setup remained as indicated in the Operational Procedure Test Part 2; however, a protocol analyzer was not required, and as a result, not used.

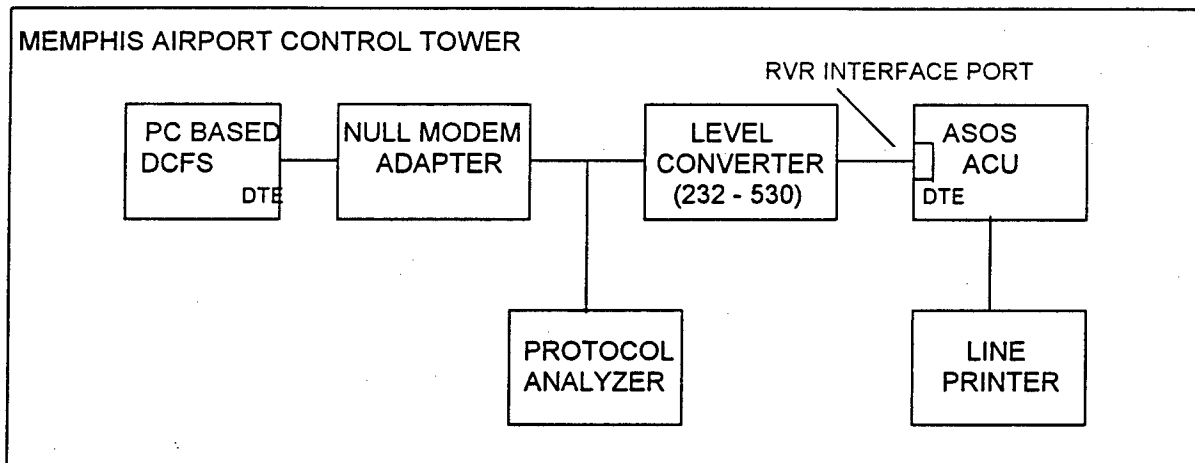

FIGURE 4.5.3.2-1. DATA COMMUNICATION FAILURE TEST SETUP

4.6 DATA COLLECTION AND ANALYSIS METHODS.

For each test conducted data collection was accomplished with use of the following equipment and resources:

- a. Protocol analyzer;
- b. Test team observations -- test conduct forms were used to record data from ASOS display screens and the RVR controller display; and
- c. ASOS printer -- for capturing ASOS METAR reports and related display screens.
- d. DPU MDT -- to capture relevant DPU parameters and status screens during testing.

Data analysis consisted primarily of reviewing analyzer data capture files to ensure proper format and content of ASOS ADUs transmitted from the New Generation RVR/ASOS Interface. This analysis was performed after test sessions were concluded. ASOS ADU transmissions displayed on the protocol analyzer were also monitored during test sessions as part of planned test sequences.

5. OPERATIONAL TEST AND EVALUATION RESULTS.

This section discusses results for each test conducted with the Final Phase New Generation RVR/ASOS Interface.

5.1 SIMULATED RVR TO ASOS TEST RESULTS.

The Simulated RVR To ASOS Test was initially conducted on June 23, 1997. Portions of the test were repeated on June 26, 1997, to obtain additional results. Total test time was approximately 4 hours. Procedures were executed as specified in section A1 of the "New Generation RVR/ASOS Interface Operational Test and Evaluation Procedures" dated June 6, 1997.

For each script file used during testing, data output from the ASOS ADU generator was successfully confirmed as received and properly displayed on all applicable ASOS screens. ASOS Long-Line RVR products were confirmed to contain RVR readings generated from the ASOS ADU generator output. One Test Trouble Report (TTR) was generated in response to ASOS performance with RVR generated specials. The problem is described in the following paragraph.

5.1.1 Problem: Initiation of ASOS RVR Special.

In response to changes in the RVR product, the threshold for initiating ASOS RVR specials is 2400 feet. During testing, it was noted that an RVR special was generated immediately for a series of RVR products increasing past 2400 feet. However, the ASOS response for a decreasing series of RVR products through the threshold was not the same. ASOS RVR specials for products decreasing through the threshold only occurred after 10 RVR product readings. Additionally, each RVR reading needed to be below the 2400-foot threshold. This problem was identified as TTR 20. For additional specifics refer to TTR# 20 contained in appendix A.

5.1.1.1 Impact.

This problem could result in a lack of RVR specials for various RVR product trends decreasing through 2400 feet for short-time periods.

5.1.1.2 Conclusions.

In general, results from this test suggest that ASOS software version 2.47 is capable of ingesting and properly displaying RVR products. Long-Line RVR products can be successfully obtained from the ASOS METAR report. However, ASOS performance in response to RVR-related specials appears to be inconsistent.

5.1.1.3 Recommendations.

ASOS performance in response to RVR-related specials should be investigated to determine compliance with design specifications and the intended operational function.

5.2 OPERATIONAL PROCEDURE TEST PART 1 RESULTS.

Operational Procedure Test Part 1 was conducted on June 24 and 25, 1997. Elapsed test time was approximately 4 hours. All ASOS ADUs were successfully transmitted and received during the test period. Although procedures were executed as specified in section A2, part 1, of the New Generation RVR/ASOS Interface Test Procedure document, some deviation in the test steps was required to coordinate test execution with the availability of MEM technicians.

Although this test resulted in the observance of three problems, New Generation RVR/ASOS Interface performance appeared to be satisfactory throughout testing. Maintenance tasks including restarts, system configuration, fault diagnosis, calibration, and MDT screen manipulation were all performed throughout these tests without the observance of significant performance problems on the New Generation RVR/ASOS Interface or New Generation RVR. Of the three problems observed during this test, two appear to be related to ASOS operation and one related to the New Generation RVR. Initial analysis results also suggest the observed problems are not directly related to New Generation RVR/ASOS Interface operation. The problems recorded as TTRs 2,4, and 5 are described in the following subparagraphs.

5.2.1 Problem: REFERENCE TO VS CALIBRATION PROCEDURE.

While performing calibration of the Long-Line VS, a reference indicating where the technician can find further instructions on how to fail the ASOS RVR product was observed to be missing from the New Generation RVR Technical Instruction (TI) manual. The reference appeared to be missing from the following TI manual locations:

- a. Paragraph 6.10.2,
- b. Paragraph 6.10.2.1,
- c. Paragraph 6.10.2.2,
- d. Paragraph 6.10.2.3,
- e. Paragraph 6.10.1,
- f. Paragraph 6.10.1.1, and
- g. Paragraph 6.10.1.2.

Additionally, a reference to paragraph 6.8.9 of the TI manual was noted to be missing from step (a) in all of the calibration procedures. This problem was documented as TTR# 2 in Appendix A.

5.2.1.1 Impact.

Improper execution of the calibration procedure and the transmission of VS calibration values to ASOS instead of the planned sensor off-line reading, i.e., FFF, during RVR sensor calibration.

5.2.1.2 Conclusions.

By FAA and NWS agreement, Long-Line VS calibration must occur according to established procedures. Inaccuracies in the calibration procedure documentation must be corrected to ensure the intended sensor readings are transmitted to ASOS during calibration scenarios.

5.2.1.3 Recommendations.

References for instructions on how to fail the ASOS RVR product should be added in the locations noted in section 5.2.1 of this report to the New Generation RVR TI manual.

5.2.2 Problem: ASOS DATE ALTERED AFTER RESET.

Hardware reset of the ASOS ACU resulted in loss of the current ASOS date and time stamp and the occurrence of a new incorrect date and time. After manually correcting the date and time stamp, an additional hardware reset resulted in a change of the system date, while the system time remained accurate. Additionally, it was noted that the hardware reset resulted in approximately 8 minutes (8 RVR readings) of missing RVR products on ASOS. A software reset performed on the ASOS ACU resulted in no missing RVR data and no time or date modifications. This problem was documented as TTR 4 in appendix A.

5.2.2.1 Impact.

ASOS resets occurring as described in TTR# 4 could result in temporary loss of Long-Line RVR data and incorrect time and date stamps of existing data.

5.2.2.2 Conclusions.

This problem suggests a performance inconsistency exists on the ASOS in response to resets initiated from ASOS ACU hardware and software.

5.2.2.3 Recommendations.

ASOS software should be modified to allow the retention of the time and date after hardware reset and prevent the loss of RVR data.

5.2.3 Problem: ASOS SYSLOG DISCREPANCIES.

It was noted that an "RVR INOPERATIONAL" message appeared in the ASOS system log after only 1 minute of data missing from the New Generation RVR/ASOS Interface. Prior to the RVR inoperational message, 11 minutes of RVR data existed on the ASOS 12-HR ARCHIVE screen. Normally, an ASOS RVR inoperational message is generated after 3 minutes of missing RVR product data. No other stimulus was apparent to cause the RVR inoperational message. An RVR non-operational message "RVRNO" was also noted on the ASOS 1-minute data screen. This problem was documented as TTR 5 in appendix A.

5.2.3.1 Impact.

Transient indications of lack of RVR data service when significant outages do not actually exist.

5.2.3.2 Conclusions.

When determining whether RVR data service from ASOS is operational or nonoperational, ASOS performance should be consistent.

5.2.3.3 Recommendations.

Further problem investigation should be considered as well as modifications to ASOS software if it can be concluded that the ASOS performance, regarding declaring the RVR operational or non-operational, is not consistent.

5.3 OPERATIONAL PROCEDURE TEST PART 2 RESULTS.

Operational Procedure Test Part 2 was conducted on June 24 and 25, 1997. Elapsed test time was approximately 4 hours which included the successful transmission and reception of all ASOS ADUs during the test period. Procedures were executed as specified in section A2, part 2, of the "New Generation RVR/ASOS Interface Test Procedures" dated June 6, 1997.

RVR CD and MDT products and ASOS ADUs were confirmed to contain the proper values in response to manipulation of the New Generation RVR VS, ALS, and RLIM measurements. RVR products sent from the RVR/ASOS interface to ASOS were confirmed to be accurate with RVR calculation software. Long-Line RVR products were confirmed as received and properly displayed on all applicable ASOS screens. Table 10 contains the results.

One problem was observed concerning performance of the New Generation RVR System. The problem is discussed in the following subparagraphs.

5.3.1 Problem: TRANSIENT OFF-LINE READINGS SENT TO ASOS.

During tests where the VS calibration plate was removed from the Long-Line VS scatter volume, the sensor RVR readings were observed to momentarily fail on the CD and MDT as sensor measurements moved towards the existing atmospheric conditions. In this scenario, the off-line reading occurred when the ASOS ADU was scheduled to be transmitted to ASOS. As a result, the off-line reading was transmitted to ASOS, although no failure existed on the Long-Line VS. Repeated scenarios where the VS calibration plate was removed or inserted resulted in intermittent occurrences of the off-line indication. Additionally, due to the small time interval whereby existing RVR products can be sent to ASOS, the further transmission of the off-line readings to ASOS was only observed in isolated cases. This problem was documented as TTR# 3 in appendix A.

TABLE 10. OPERATIONAL PROCEDURE TEST OUTPUT

ALS (ft-lamberts)	RLIM EDGE/CENTER SETTING	VS EXTINCTION COEFFICIENT (km^{-1})	RVR PRODUCT (ft)	ASOS RVR
2000	0	w/ cal plate hi	100	100
2000	3	w/ cal plate lo	300	300
2000	5	on field site	44,674 (60+)	60+
2000	5	w/ cal plate lo	400	400
2000	5	w/ plug	6500	6500
2000	5	sensor fail	FFF	FFF
6000	0	w/ cal plate hi	100	100
6000	3	w/ cal plate lo	200	200
6000	5	on field site	54,602 (60+)	60+
6000	5	w/ cal plate lo	200	200
6000	5	w/ plug	6500	6500
6000	5	Sensor fail	FFF	FFF
12000	0	w/ cal plate hi	100	100
12000	3	w/ cal plate lo	200	200
12000	5	On field site	40,951 (60+)	60+
12000	5	W / cal plate lo	300	300
12000	5	w/ plug	6500	6500
12000	5	Sensor fail	FFF	FFF

5.3.1.1 Impact.

RVR product changes due to calibration plate insertion or removal could result in transient RVR readings on ASOS which indicate that RVR data is missing or the New Generation RVR System is not operational.

5.3.1.2 Conclusion.

Evidence exists suggesting that this problem is inherent to the New Generation RVR product calculation during some extinction coefficient changes measured by the visibility sensor. For example, the New Generation RVR System is designed to fail the product, i.e., display FFF, if the extinction coefficient rate of change is above the design threshold.

As a result, the problem is not directly related to operation of the New Generation RVR/ASOS Interface. Additionally, no evidence exists indicating that this problem could be encountered during natural changes in atmospheric conditions. These aforementioned factors indicate that this problem should have a minimal, if any impact on the New Generation RVR performance.

5.3.1.3 Recommendations.

Strict adherence to the calibration procedure as defined in the New Generation RVR TI manual should prevent occurrence of the problem as stated in TTR #1.

5.3.2 Problem: Calibration Parameter Mismatch.

During a general inspection of DPU and SIE parameters, the DPU "Rate of Change Limit" parameter did not match the same parameter on the VS SIE. A DPU reset was performed to correct the mismatch. The exact cause of the mismatch could not be determined during testing.

5.3.2.1 Impact.

A mismatch for the same parameter on the DPU and SIE could lead to confusion for the RVR system operator in determining the current system status for the Rate of Change Limit parameter.

5.3.2.2 Conclusion.

This problem appears to have a negligible impact if any, on operation of the New Generation RVR/ASOS Interface and additionally appears to be not related to its operation.

5.3.2.3 Recommendation.

Additional analysis or testing should be considered to determine if the problem occurs with other RVR DPU parameters that also exist on the SIE.

5.4 DATA COMMUNICATION FAILURE TEST RESULTS.

The Data Communication Failure Test was conducted on June 26, 1997. The Elapsed test time was approximately 5 hours and resulted in the transmission of approximately 600 ASOS ADUs. Procedures were executed as specified in section A3 of the "New Generation RVR/ASOS Interface Test Procedures, dated June 6, 1997.

Although no problems were observed in the operation of the New Generation RVR/ASOS Interface, three problems were noted in ASOS performance during communication problem simulation. The problems are discussed in the following paragraphs.

5.4.1 Problem: INCONSISTENT ASOS INDICATION OF RVR OUTAGE.

During a test where the baud rate of the ASOS ADU data was changed from 2400 bps to 19200 bps, an "RVRNO" message was observed on the ASOS 1-Minute data screen but no matching "RVR INOPERATIONAL" message was observed in the ASOS system log. Additionally, resetting the baud rate to 2400 bps resulted in the absence of RVR products for 10 minutes, i.e., 10 RVR readings rather than the expected 8 minutes (8 readings). This problem was documented as TTR 17 in appendix A.

5.4.1.1 Impact.

This problem could result in discrepancies on ASOS display screens concerning the status of the RVR system and data.

5.4.1.2 Conclusions.

Since ASOS RVR outages typically are automatically recorded on all RVR-related screens, i.e., 1-Minute data, system log, 12-HR ARCHIVE, etc., this problem suggests that a discrepancy may exist on ASOS concerning the system notification of RVR data availability problems.

5.4.1.3 Recommendations.

To prevent confusion for the ASOS operator, ASOS performance regarding the declaration of RVR system status should be consistent across the various ASOS display screens. Modification to ASOS software should be considered in correcting the problem.

5.4.2 Problem: MISSING TRANSMISSION ERROR MESSAGE.

In response to ASOS ADUs containing block check code errors, ASOS "RVRNO" and "RVR INOPERATIONAL" messages were observed as well as missing data for the period containing errors. However, a message noting a transmission error was expected, but was not observed. This problem was documented as TTR 18 in appendix A.

5.4.2.1 Impact.

The absence of a message indicating existence of a transmission error could result in a lack of information indicating the source of the problem. This could also create additional delays in resolving communication problems between the New Generation RVR and ASOS.

5.4.2.2 Conclusions.

This problem suggests that all of the ASOS error reporting functions are not operating completely in response to communication problems with RVR data.

5.4.2.3 Recommendations.

Since the capability exists on ASOS to provide specific information regarding communication problems with the New Generation RVR/ASOS Interface, this function should perform as intended. Modification to ASOS software should be considered for correcting the problem.

5.4.3 Problem: FAILURE TO DETECT PARITY ERROR.

In response to a 10-minute period of parity errors generated from a data communication fault simulator, no detection of the errors were observed on ASOS. RVR data was continually displayed on the ASOS 12-HOUR and 1-Minute data screens throughout the period in which the parity errors were transmitted. This problem was documented as TTR 19 in appendix A.

5.4.3.1 Impact.

An ASOS failure to detect parity error from RVR data could result in the display and/or further transmission of RVR data corrupted by communication failure or problem.

5.4.3.2 Conclusions.

This problem suggests that a method for detecting communication parity errors does not exist or is not operating as intended on ASOS.

5.4.3.3 Recommendations.

To prevent the display of and further transmission of RVR data corrupted by communication problems, ASOS should detect parity errors and indicate that a communication problem exists. Further display and transmission of RVR data should be disabled until the communication problem is corrected.

5.5 EXTENDED OPERATION AND EVALUATION TEST RESULTS.

Extended Operation and Evaluation of the MEM New Generation RVR/ASOS Interface has resulted in no additional performance problems. Remote data analysis results indicate that the interface has functioned continuously without error since the initiation of the test on June 27, 1997.

5.5.1 Conclusions.

The New Generation RVR/ASOS Interface is capable of providing Long-Line RVR data during operational conditions at MEM. Performance degradation of the MEM New Generation RVR System has not occurred as a result of operation of the interface. The lack of New Generation RVR performance discrepancies suggest that the interface is suitable for incorporation in the New Generation RVR and FAA National Airspace System (NAS).

5.5.2 Recommendations.

The New Generation RVR/ASOS Interface should be considered for deployment throughout the NAS.

5.6 NEW GENERATION RVR/ASOS INTERFACE INSTALLATION RESULTS.

As part of the MEM OT&E effort, installation of New Generation RVR/ASOS Interface hardware and software was performed under direction of official equipment modification documentation and the TI manual. During installation activities, discrepancies in the documentation were also recorded as TTRs similar to New Generation RVR and ASOS Interface performance issues. Installation activities resulted in the issuance of 10 TTRs concerning the Engineering Equipment Modification documentation or the New Generation RVR TI manual. Refer to TTR forms

contained in appendix A for detailed descriptions of these problems.

5.7 OPERATIONAL TEST AND EVALUATION LIMITATIONS.

OT&E activities were limited due to the unavailability of an MPS, which could provide remote monitor and control capability. As a result, remote monitoring and control parameters relating to the RVR/ASOS Interface and related modifications to New Generation RVR software could not be evaluated during testing. As mentioned in section 4.1, the testing for these functions was deferred.

Other OT&E limitations included an inability to replicate a variety of site-dependent equipment scenarios (e.g., modems, Data Service Unit/Channel Service Unit, long cable lengths) which may be required to facilitate communication between the New Generation RVR/ASOS Interface and ASOS. Site dependent environment or equipment required may introduce performance issues; e.g., noise, errors in data communication, etc., not encountered during OT&E.

6. CONCLUSIONS.

Memphis International Airport (MEM) Operational Test and Evaluation (OT&E) results provide evidence that the New Generation Runway Visual Range (RVR)/Automated Surface Observing System (ASOS) Interface can successfully perform its function of providing RVR products to ASOS as defined in 50-SANW-1-00050. The results also suggest that the interface can reliably provide RVR products during typical and atypical operating conditions and New Generation RVR configurations. The lack of significant New Generation RVR/ASOS Interface performance problems and lack of New Generation RVR System performance degradation during testing suggests that the interface can be successfully integrated with the New Generation RVR and ASOS.

New Generation RVR-related problems observed during testing appear to have a minimal, if any impact on New Generation RVR/ASOS Interface performance and, in general, operation of the New Generation RVR. These results suggest these problems may be corrected with TI manual or Engineering Equipment Modification documentation updates. Minor changes to the New Generation RVR may also correct the observed problems.

Although New Generation RVR/ASOS Interface performance was satisfactory and the problems observed appear to be noncritical, the OT&E effort cannot be considered complete until remote maintenance monitoring functions for the interface and the system have been evaluated. The lack of significant performance issues

resulting from these tests and the existing MEM results could provide a basis for national deployment of the interface. ASOS performance issues observed during testing suggest that modifications to ASOS software and/or documentation updates may be required to prevent further occurrences of the problems noted during OT&E. Additional testing is also recommended with the New Generation RVR/ASOS Interface and/or simulators to determine if ASOS modifications or additional procedures have corrected the observed problems.

7. RECOMMENDATIONS.

It is recommended that Operational Test and Evaluation (OT&E) activities featuring an analysis of the New Generation Runway Visual Range (RVR)/Automated Surface Observing System (ASOS) Interface remote monitoring be completed. Deployment of the New Generation RVR/ASOS Interface is recommended, but is contingent on the successful completion and satisfactory passing of remote maintenance monitoring tests.

Modifications to ASOS software should be considered for correcting problems relating to ASOS performance during OT&E. It is recommended that additional testing with the New Generation RVR System or simulators be performed to verify corrections to problems observed during OT&E.

8. ACRONYMS.

ACU	Acquisition Control Unit
ADAS	Automated Weather Observing System Data
ADU	Application Data Unit
ALS	Ambient Light Sensor
APMT	Associate Program Manager for Test
ASOS	Automated Surface Observing System
ATCT	Airport Traffic Control Tower
AWOS	Automated Weather Observing System
BCC	Block Check Code
bps	bits per second
CD	Controller Display
COI	Critical Operational Issue
CSU	Channel Service Unit
DCE	Data Communication Equipment
DCFS	Data Communication Fault Simulator
DPU	Data Processing Unit
DQT	Design Qualification Testing
DSU	Data Service Unit
DTE	DATA Terminal Equipment
EIA	Electronic Industries Association
EEPROM	Electrically Erasable Programmable Read Only
EEM	Engineering Equipment Modification
ETX	End of Transmission
EU	External User
FAA	Federal Aviation Administration
FSS	Flight Service Station
HP	Hewlett Packard
ICD	Interface Control Document
IMCS	Interim Monitoring and Control Software
IFR	Instrument Flight Rules
MAOR	Minimum Acceptable Operational Requirements
MDT	Maintenance Data Terminal
METAR	Aviation Routine Weather Report
MPS	Maintenance Processor System
NAS	National Airspace System
NOAA	National Oceanic and Atmospheric Administration
NWS	National Weather Service
OT&E	Operational Test and Evaluation
PC	Personal Computer
RLIM	Runway Light Intensity Monitor
RMM	Remote Maintenance Monitoring
RVR	Runway Visual Range
RS	Recommended Standard
SAO	Surface Aviation Observation
SIE	Sensor Interface Electronics
SOH	Start of Header

STX
TRACON
TTR

Start of Text
Terminal Radar Approach Control
Test Trouble Report

APPENDIX A

TEST TROUBLE REPORTS

RVR/ASOS INTERFACE TEST TROUBLE REPORT	TTR-001
---	---------

DATE: 6/24/97	TIME: AM	SITE: MEM
---------------	----------	-----------

SYSTEMS/COMPONENTS IN ISSUE:					
RVR DPU	<input checked="" type="checkbox"/>	RVR MDT	<input type="checkbox"/>	ASOS ACU	<input type="checkbox"/>
RVR SIE	<input type="checkbox"/>	INTERIM INTERFACE	<input type="checkbox"/>	ASOS DISPLAY	<input type="checkbox"/>
RVR CD	<input type="checkbox"/>	FINAL INTERFACE	<input checked="" type="checkbox"/>	MPS	<input type="checkbox"/>

TEST EQUIPMENT USED:
PROTOCOL ANALYZER <input checked="" type="checkbox"/>
OTHER:

--

TEST PLAN ID:
TEST PROCEDURE ID: A2 STEP(S):

DESCRIPTION OF ISSUE/PROBLEM: "Transient "Off-line" Reading Sent To ASOS"
--

After removing the calibration plate, RVR readings were noted to momentarily go "off-line" Or fail as the RVR product moved towards atmospheric readings. In this scenario, the Off-line reading occurred when the ASOS RVR product was scheduled to be transmitted and As a result an off-line reading was sent to ASOS, although no failure existed on the Long Line sensor.

NEW GENERATION RVR SOFTWARE VERSION ID: MPU/PPU-5.0, ASOS CCA1.0, VS-4.1
ASOS SOFTWARE VERSION ID: 2.47

Michael Jones	6/24/97
ISSUE/PROBLEM WITNESS	DATE

Michael Jones	6/26/97
FAA TEST DIRECTOR/REPRESENTATIVE	DATE

Peggy Hoch	6/24/97
NWS REPRESENTATIVE	DATE

NOAA REPRESENTATIVE	A DATE

RVR/ASOS INTERFACE TEST TROUBLE REPORT			TTR-002
DATE: 6/24/97	TIME: 10:00AM	SITE: MEM	
SYSTEMS/COMPONENTS IN ISSUE: TI-6560.17 On Site Manual			
RVR DPU <input type="checkbox"/>	RVR MDT <input type="checkbox"/>	ASOS ACU <input type="checkbox"/>	
RVR SIE <input type="checkbox"/>	INTERIM INTERFACE <input type="checkbox"/>	ASOS DISPLAY <input type="checkbox"/>	
RVR CD <input type="checkbox"/>	FINAL INTERFACE <input type="checkbox"/>	MPS <input type="checkbox"/>	
TEST EQUIPMENT USED:			
PROTOCOL ANALYZER <input type="checkbox"/>			
OTHER:			
N/A			
TEST PLAN ID:			
TEST PROCEDURE ID: A-2		STEP(S): 56	
DESCRIPTION OF ISSUE/PROBLEM:			
In step (a) of VS/SIE calibration (section 6.10.2.1), VS calibration verification (section 6.10.2.1), VS Transmitter Window Contamination Verification (section 6.10.2.2), and VS Receiver Windows Contamination Verification (section 6.10.2.3) there needs to be a reference stating where the tech can refer to "fail" the ASOS product. Also needed in section 6.10.1, section 6.10.1.1, and section 6.10.1.2.			
"Refer to paragraph 6.8.9" needs to be added to step (a) in all of these procedures.			
NEW GENERATION RVR SOFTWARE VERSION ID: N/A			
ASOS SOFTWARE VERSION ID:			
Mike McKinney	6/24/97		
ISSUE/PROBLEM WITNESS		DATE	
Mike McKinney	6/24/97		
FAA TEST DIRECTOR/REPRESENTATIVE		DATE	
NWS REPRESENTATIVE		DATE	
NOAA REPRESENTATIVE		DATE	

RVR/ASOS INTERFACE TEST TROUBLE REPORT		TTR-003
DATE: 6/24/97	TIME: Various	SITE: MEM
SYSTEMS/COMPONENTS IN ISSUE:		
RVR DPU <input checked="" type="checkbox"/>	RVR MDT <input checked="" type="checkbox"/>	ASOS ACU <input type="checkbox"/>
RVR SIE <input type="checkbox"/>	INTERIM INTERFACE <input type="checkbox"/>	ASOS DISPLAY <input type="checkbox"/>
RVR CD <input type="checkbox"/>	FINAL INTERFACE <input checked="" type="checkbox"/>	MPS <input type="checkbox"/>
TEST EQUIPMENT USED:		
PROTOCOL ANALYZER <input type="checkbox"/>		
OTHER: MDT		
TEST PLAN ID:		
TEST PROCEDURE ID: A.2 STEP(S): 69, 70, and 75		
DESCRIPTION OF ISSUE/PROBLEM:		
During testing, it appeared that the RVR product would briefly (a few seconds) be reported on the MDT as "FFF" during period of time when the rate of change was high.		
(when the VS extinction coefficient was increasing or decreasing at a quick rate, such as installing/removing the calibration plate).		
MDT screen showing problem was "Data.Product"		
NEW GENERATION RVR SOFTWARE VERSION ID: 5.0		
ASOS SOFTWARE VERSION ID: 2.47		
Mike McKinney	6/24/97	
ISSUE/PROBLEM WITNESS		DATE
Mike McKinney	6/24/97	
FAA TEST DIRECTOR/REPRESENTATIVE		DATE
Peggy Hoch	6/24/97	
NWS REPRESENTATIVE		DATE
NOAA REPRESENTATIVE		DATE

RVR/ASOS INTERFACE TEST TROUBLE REPORT

TTR-004

DATE: 6/24/97

TIME: UTC 14:27

SITE: MEM

SYSTEMS/COMPONENTS IN ISSUE:RVR DPU RVR MDT ASOS ACU RVR SIE INTERIM INTERFACE ASOS DISPLAY RVR CD FINAL INTERFACE MPS **TEST EQUIPMENT USED:**PROTOCOL ANALYZER

OTHER: N/A

TEST PLAN ID:

TEST PROCEDURE ID: A.2

STEP(S): 51, pg. A.2-32

DESCRIPTION OF ISSUE/PROBLEM:

A hardware reset (reset from button on ACU) caused the ASOS date and time to be altered. The date became 12/8/97, time 00:10 (Refer to attachment). Another hardware reset was performed in the same manner after manually correcting the date and time. The second reset caused the date to be altered, but the time remained accurate. It took 8 RVR readings to get RVR back after this reset. After manually correcting the date, a software reset was performed from the "MAINT" page. Date and time were OK.

NEW GENERATION RVR SOFTWARE VERSION ID: 5.0

ASOS SOFTWARE VERSION ID: 2.47

Peggy Hoch

6/24/97

ISSUE/PROBLEM WITNESS**DATE**

Mike McKinney

6/24/97

FAA TEST DIRECTOR/REPRESENTATIVE**DATE**

Peggy Hoch

6/24/97

NWS REPRESENTATIVE**DATE****NOAA REPRESENTATIVE****DATE**

TOOK 8 READINGS TO GET RVR BACK AFTER 2ND RESET.

PMH LOGGED ON A OBSERVER FROM OID#1 ON 06/24/97 AT 14:27:02

06/24/1997 14:27 *ST 1406 RVR INOPERATIONAL

06/24/1997 14:27 EDIT-ENTRY KMEM 242027Z 12006KT 10SM CLR 34/21 A3002 RMK
A02 SNO PNO (PMH)

06/24/1997 14:27 EDIT-EXIT KMEM 242027Z 13006KT 10SM CLR 34/21 A3002 RMK
A02 SNO PNO (PMH)

06/24/1997 14:27 EDIT-ENTRY KMEM 242027Z 13006KT 10SM CLR 34/21 A3002 RMK
A02 PNO (PMH)

06/24/1997 14:27 EDIT ENTRY KMEM 242027Z 13007KT 1/2SM HZ CLR 34/21 A3002
RMK A02 RVRNO PNO (PMH)

PMH LOGGED OFF AS OBSERVER FROM OID#1 ON 06/24/97 AT 14:28:22
PMH LOGGED OFF AS OBSERVER FROM OID#1 ON 06/24/97 AT 15:19:39

06/24/1997 15:19 EDIT-ENTRY KMEM 242119Z 14011KT 10SM CLR 34/21 A2999 RMK
A02 TSNO PNO (PMH)

06/24/1997 15:19 EDIT-EXIT KMEM 242119Z 14011KT 1/2SM HZ CLR 34/21 A2999
RMK A02 RVRNO PNO (PMH)

06/24/97 15:37 *ST 1407 RVR OPERATIONAL

PMH LOGGED OFF AS OBSERVER FROM OID#1 ON 06/24/97 AT 15:57:43
PMH LOGGED OFF AS OBSERVER FROM OID#1 ON 06/24/97 AT 15:57:43

06/24/1997 15:57 EDIT-ENTRY KMEM 242157Z VRB05KT 9SM CLR 33/21 A2998 RMK
A02 PNO (PMH)

06/24/1997 15:57 EDIT-ENTRY KMEM 242157Z VRB05KT 1/2SM HZ CLR 33/21 A2998
RMK A02 PNO (PMH)

PMH LOGGED OFF AS OBSERVER FROM OID#1 ON 06/24/97 AT 15:58:38

*** SYSTEM COMING UP!!! --- DOWNTIME 167 1193029:46. ***

*** SYSTEM COMING UP!!! --- DOWNTIME 167 1193029:46. ***

*** SYSTEM COMING UP!!! --- DOWNTIME 167 1193029:46. ***

12/08/97 00:10 *ST 0140 SYSTEM ACTIVATED - WARM START PERFORMED

12/08/97 00:10 *ST 1012 CEILOMETER #1 DATA QUALITY BAD

12/08/97 00:10 *ST 1014 CEILOMETER #3 DATA QUALITY BAD

MEMPHIS INTERNATIONAL ARPT

LISTING SAOS FROM: 12/07/1997 00:00 THRU 12/07/1997 23:59

SAO LISTING COMPLETE, 0 SAO (S) LISTED.

ASOS OID PRINTOUT FOLLOWS:

DATE AND TIME INCORRECT AFTER WARM START

0:16:01 12/08/97 0616Z

MEMPHIS INTERNATIONAL ARPT

SKY	= MM	TEMP/DEWPT	= 33.3 /21.1 C 92 /70 F
VISIBILITY	= M	WIND DIR/SPD	= VRB/06
RVR	= RVRNO	ALTIMETER	= 29.98
PRESENT WX	=		

REMARKS = RMK A02 TSNO RVRNO PNO

MAG WIND DIR/SPD: 190/07 170V240

RELATIVE HUMIDITY: 48 STATION PRESSURE: 29.66

SEA LVL PRESSURE: 1014.5 PRESSURE ALTITUDE: 280

DENSITY ALTITUDE: 2500

PMH LOGGED ON AS SYSTEM MANAGER FROM OID#1 ON 12/08/97 AT 00:16:48

06/24/97 17:04 *ST 1407 RVR OPERATIONAL

PMH LOGGED OFF AS SYSTEM MANAGER FROM OID#1 ON 06/24/97 AT 17:04:21

ASOS OID PRINTOUT FOLLOWS:

17:04:28 06/24/97 2304Z

MEMPHIS INTERNATIONAL ARPT

SKY	= MM	TEMP/DEWPT	= 33.3 /21.7 C 92 /71 F
VISIBILITY	= 9SM	WIND DIR/SPD	= 190/07
RVR	= R36L/P6000FT	ALTIMETER	= 29.98

REMARKS = RMK A02 TSNO PNO

MAG WIND DIR/SPD: 190/07

RELATIVE HUMIDITY: 50 STATION PRESSURE: 29.66
PRESSURE ALTITUDE: 280
SEA LVL PRESSURE: 1014.5 DENSITY ALTITUDE: 2500

PMH LOGGED ON AS OBSERVER FROM OID#1 ON 06/24/97 AT 17:08:10
06/24/1997 17:08 EDIT-ENTRY KMEM 242308Z 17005KT 9SM 33/21 A2998 RMK A02
PNO \$(PMH)
06/24/1997 17:08 EDIT-EXIT KMEM 242308Z 17005KT 9SM CLR 33/21 A2998 RMK
A02 PN \$ (PMH)

*** SYSTEM COMING UP!!! --- DOWNTIME 167 00:00. ***
*** SYSTEM COMING UP!!! --- DOWNTIME 167 00:00. ***
*** SYSTEM COMING UP!!! --- DOWNTIME 167 00:00. ***

02/08/97 17:09 *ST 0140 SYSTEM ACTIVATED - WARM START PERFORMED

02/08/97 17:09 *ST 1012 CEILOMETER #1 DATA QUALITY BAD

02/08/97 17:09 *ST 1014 CEILOMETER #3 DATA QUALITY BAD

ASOS OID PRINTOUT FOLLOWS:

DATE INCORRECT AFTER WARM START

17:09:51 12/08/97 2309Z

MEMPHIS INTERNATIONAL ARPT

SKY = MM TEMP/DEWPT = M /M C M /M F
VISIBILITY = M WIND DIR/SPD = M /M
RVR = RVRNO ALTIMETER = M
PRESENT WX=

REMARKS = RMK A02 FZRANO TSNO RVRNO PNO

MAG WIND DIR/SPD: M /M

RELATIVE HUMIDITY: M STATION PRESSURE: M
PRESSURE ALTITUDE: M
SEA LVL PRESSURE: M DENSITY ALTITUDE: M

ASOS OID PRINTOUT FOLLOWS:

10:29 12/08/97 2310Z

UTC	VIS1	D/N1	VIS2	D/N2	VIS3	D/N3	WIND	DIR/SPD	5SEC	WIND	RVR
2244	0.202	D			0.243	D	183	7	167	12	36L60+
2245	0.204	D			0.252	D	155	8	146	8	36L60+
2246	0.209	D			0.251	D	149	7	165	6	36L60+
2247	0.204	D			0.255	D	152	6	149	8	36L60+
2248	0.207	D			0.249	D	153	8	150	10	36L60+
2249	0.205	D			0.245	D	155	8	161	8	36L60+
2250	0.202	D			0.245	D	164	7	172	8	36LFFF
2251	0.200	D			0.244	D	169	7	171	7	36L60+
2252	0.204	D			0.260	D	164	5	186	5	36L60+
0611	0.205	D			0.251	D	M	M	195	5	36L60+
0612	0.208	D			0.254	D	186	5	190	8	36L60+
0613	0.219	D			0.253	D	189	7	179	9	36L60+

12HR ARCHIVE

ASOS OID PRINTOUT FOLLOWS:

17:10:43 12/08/97 2310Z

MEMPHIS INTERNATIONAL ARPT

UTC	VIS1	D/N1	VIS2	D/N2	VIS3	D/N3	WIND	DIR/SPD	5SEC	WIND	RVR
0614	0.209	D			0.253	D	185	7	191	8	36L60+
0615	0.204	D			0.255	D	190	6	179	9	36L60+
0616	0.202	D			0.255	D	186	7	178	10	36L60+
0617	0.203	D			0.256	D	181	8	177	8	36L60+
0618	0.202	D			0.250	D	195	7	205	7	36L60+
2303	0.205	D			0.259	D	203	6	195	7	36L60+
2304	0.202	D			0.260	D	190	7	172	10	36L60+
2305	0.205	D			0.264	D	173	8	164	9	36L60+
2306	0.201	D			0.265	D	161	8	146	8	36L60+
2307	0.204	D			0.258	D	155	6	156	6	36L60+
2308	0.201	D			0.248	D	168	5	174	6	36L60+
2309	M	D			M	D	M	M	143	6	36L60+

12HR ARCHIVE

PMH LOGGED ON AS SYSTEM MANAGER FROM OID#1 ON 12/08/97 AT 17:11:42

DATE AND TIME OK WHEN RESET VIA MAINT PAGE

PERFORMED 2 SOFT RESETS MAIN-PREV-SEL-RESET

TASK ID # 10000000, RUNTIME ERROR: MANUAL RESTART @ 4AEB2E, 493320, 480D70, 49DF82, 47DC7E, 47DC92, 49DEA0, 47E49A, 475182, 47EC10

*** SYSTEM COMING UP!!! --- DOWNTIME 0 00:00. ***
*** SYSTEM COMING UP!!! --- DOWNTIME 0 00:00. ***
*** SYSTEM COMING UP!!! --- DOWNTIME 0 00:00. ***

06/26/97 07:31 *ST 0140 SYSTEM ACTIVATED - WARM START PERFORMED

06/26/97 07:31 *ST 1012 CEILOMETER #1 DATA QUALITY BAD

06/26/97 07:31 *ST 1014 CEILOMETER #3 DATA QUALITY BAD

PMH LOGGED ON AS SYSTEM MANAGER FROM OID#1 ON 06/26/97 AT 07:35:46

TASK ID # 10000000, RUNTIME ERROR: MANUAL RESTART @ 4AEB2E, 493320, 480D70, 49DF82, 47DC7E, 47DC92, 49DEA0, 47E49A, 475182, 47EC10

*** SYSTEM COMING UP!!! --- DOWNTIME 0 00:00. ***
*** SYSTEM COMING UP!!! --- DOWNTIME 0 00:00. ***
*** SYSTEM COMING UP!!! --- DOWNTIME 0 00:00. ***

06/26/97 07:36 *ST 0140 SYSTEM ACTIVATED - WARM START PERFORMED

06/26/97 07:36 *ST 1012 CEILOMETER #1 DATA QUALITY BAD

06/26/97 07:36 *ST 1014 CEILOMETER #3 DATA QUALITY BAD

PURPOSE:

THIS WAS AN ATTEMPT TO RECREATE THE RESET PROBLEM (WHERE RESET (BY PUSHING BUTTON ON CPU) CAUSED BAD DATE/TIME).

ASOS OID PRINTOUT FOLLOWS:
07:41:01 06/26/97 1341Z

MEMPHIS INTERNATIONAL ARPT

SITE PHYSICAL CHARACTERISTICS

STATION

NAME: MEMPHIS INTERNATIONAL ARPT
IDENTIFIER: MEM
COMMISSIONED: NON DATE: 06/26/97
ATTENDED: NO TIME: 13:40:43

UTC

OPEN 24 HOURS: YES UTC TO LST OFFSET: -6
OPENING TIME:
CLOSING TIME:
ELEVATION: 284 FEET LATITUDE 35.02N
LONGITUDE: 089.59W

FIELD ELEVATION 332 FEET
PRESSURE SENSOR ELEV. 286 FEET

METAR SWITCH DATE: 07/01/96 UTC
METAR SWITCH TIME: 07:45:00 UTC

OBS HOURLY REPORT TIME: 50 PHYSICAL
OBS EDIT TIME: 5:00
OBS HOURLY TRANSMIT TIME: 55:00
SHEF HOURLY TRANSMIT TIME: 0

PMH LOGGED ON AS SYSTEM MANAGER FROM OID#1 ON 06/26/97 AT 07:41:42

ASOS OID PRINTOUT FOLLOWS:

07:41:56 06/26/97 1341Z

MEMPHIS INTERNATIONAL ARPT

STATION ID (XXX): MEM PRODUCT ID (NNN): MTT
FORECAST OFFICE (CCC): MEM 15-MIN SHEF ID (NNN): RRX
AFOS: 1-HOUR SHEF ID (NNN): RRY

ADDRESS: 100

15-MIN SHEF ADDRESS:

1-HOUR SHEF ADDRESS:

STATION IDS/PHONE NUMBERS

STATION 1:

ADAS:

ASOS ADDRESS: 100

STATION 2:

TCCC:

TCCC ADDRESS: 100

STATION 3:

AOMC:

PRIMARY PHONE NO: 18002534717

SECONDARY PHONE NO: 18004341133

AOMC 1200 BAUD: NO

MESSAGE FORMAT TYPE: I

PARITY SELECTION: NONE

REPLY REQUEST: NO

BUSY ATTEMPT TIME: 1

REPLY TIME: 1

BACKUP FOR ADAS: NO

WMO IDENTIFIER

EXTERNAL

06/26/97 07:46 *ST 1407 RVR OPERATIONAL
PMH LOGGED OFF AS SYSTEM MANAGER FROM OID#1 ON 06/26/97 AT 07:47:45

PERFORMED 2 HARD RESET (PUSH RESET BUTTON)

*** SYSTEM COMING UP!!! --- DOWNTIME 0 00:00. ***
*** SYSTEM COMING UP!!! --- DOWNTIME 0 00:00. ***
*** SYSTEM COMING UP!!! --- DOWNTIME 0 00:00. ***

06/26/97 07:48 *ST 0140 SYSTEM ACTIVATED - WARM START PERFORMED

06/26/97 07:48 *ST 1012 CEILOMETER #1 DATA QUALITY BAD

06/26/97 07:48 *ST 1014 CEILOMETER #3 DATA QUALITY BAD

ASOS OID PRINTOUT FOLLOWS:

07:49:16 06/26/97 1349Z DATA/TIME OK MEMPHIS INTERNATIONAL ARPT

SKY	=	TEMP/DEWPT	=	/C/F
VISIBILITY	=	WIND DIR/SPD	=	
PRESENT WX	=	ALTIMETER	=	
REMARKS	=			

MAG WIND DIR/SPD:	M /M	STATION PRESSURE:	M
RELATIVE HUMIDITY:	M	PRESSURE ALTITUDE:	M
SEA LVL PRESSURE:	M	DENSITY ALTITUDE:	M

PMH LOGGED ON AS SYSTEM MANAGER FROM OID#1 ON 06/26/97 AT 07:49:56
PMH LOGGED OFF AS SYSTEM MANAGER FROM OID#1 ON 06/26/97 AT 07:50:17

ASOS OID PRINTOUT FOLLOWS:

07:50:38 06/26/97 1350Z ***HOURLY*** MEMPHIS INTERNATIONAL ARPT
SKY = MM TEMP/DEWPT = M /M C M /M F
VISIBILITY = M WIND DIR/SPD = 250/03
RVR = RVRNO ALTIMETER = M
PRESENT WX=

REMARKS = RMK A02 SLPNO FZRANO TSNO RVRNO PNO

TESTM KMEM 261350Z AUTO 25003KT RMK A02 SLPNO FZRANO TSNO RVRNO PNO
\$

MAG WIND DIR/SPD: VRB/03

RELATIVE HUMIDITY: M STATION PRESSURE: M
PRESSURE ALTITUDE: M
SEA LVL PRESSURE: M DENSITY ALTITUDE: M

06/26/97 07:58 *ST 1407 RVR OPERATIONAL

*** SYSTEM COMING UP!!! --- DOWNTIME 0 00:00. ***
*** SYSTEM COMING UP!!! --- DOWNTIME 0 00:00. ***
*** SYSTEM COMING UP!!! --- DOWNTIME 0 00:00. ***

2ND HARD RESET

06/26/97 07:59 *ST 0140 SYSTEM ACTIVATED - WARM START PERFORMED

06/26/97 07:59 *ST 1012 CEILOMETER #1 DATA QUALITY BAD

06/26/97 07:59 *ST 1014 CEILOMETER #3 DATA QUALITY BAD

ASOS OID PRINTOUT FOLLOWS:

08:00:31 06/26/97 1400Z *DATE/TIME OK* MEMPHIS INTERNATIONAL ARPT

SKY = MM TEMP/DEWPT = M /M C M /M F
VISIBILITY = M WIND DIR/SPD = M /M
RVR = RVRNO ALTIMETER = M
PRESENT WX=

REMARKS = RMK A02 FZRANO TSNO RVRNO PNO

MAG WIND DIR/SPD: M /M
RELATIVE HUMIDITY: M STATION PRESSURE: M
PRESSURE ALTITUDE: M
SEA LVL PRESSURE: M DENSITY ALTITUDE: M

RVR CAME BACK FIRST TIME AFTER 8 MINUTES AND SECOND TIME AFTER 8 MINUTES.

RVR/ASOS INTERFACE TEST TROUBLE REPORT			TTR-005
DATE: 6/24/97	TIME: UTC 14:27	SITE: MEM	
SYSTEMS/COMPONENTS IN ISSUE:			
RVR DPU <input type="checkbox"/>	RVR MDT <input type="checkbox"/>	ASOS ACU <input checked="" type="checkbox"/>	
RVR SIE <input type="checkbox"/>	INTERIM INTERFACE <input type="checkbox"/>	ASOS DISPLAY <input checked="" type="checkbox"/>	
RVR CD <input type="checkbox"/>	FINAL INTERFACE <input type="checkbox"/>	MPS <input type="checkbox"/>	
TEST EQUIPMENT USED:			
PROTOCOL ANALYZER <input type="checkbox"/>			
OTHER: MDT			
N/A			
TEST PLAN ID:			
TEST PROCEDURE ID: A.2 STEP(S): 51 P. A.2-32			
DESCRIPTION OF ISSUE/PROBLEM:			
A hardware reset (reset from button on ACU) caused the ASOS date and time to be altered.			
The date became 12/8/97, time 00:10 (Refer to attachment). Another hardware reset was			
performed in the same manner after manually correcting the date and time. The second			
reset caused the date to be altered, but the time remained accurate. It took 8 RVR readings			
to get RVR back after this reset. After manually correcting the date, a software reset was			
performed from the "MAINT" page. Date and time were OK.			
NEW GENERATION RVR SOFTWARE VERSION ID: 5.0			
ASOS SOFTWARE VERSION ID: 2.47			
ISSUE/PROBLEM WITNESS		DATE	
Mike McKinney		6/24/97	
FAA TEST DIRECTOR/REPRESENTATIVE		DATE	
NWS REPRESENTATIVE		DATE	
NOAA REPRESENTATIVE		DATE	

ASOS OID PRINTOUT FOLLOWS:
13:03:01 06/25/97 1903Z

MEMPHIS INTERNATIONAL ARPT

UTC	VIS1	D/N1	VIS2	D/N2	VIS3	D/N3	WIND	DIR/SPD	5SEC	WIND	RVR
1851	0.092	D			0.105	D	148	8	136	9	36L60+
1852	0.084	D			0.104	D	140	8	145	11	36L60+
1853	0.086	D			0.108	D	136	7	130	7	36L60+
1854	0.085	D			0.106	D	134	6	141	7	36L60+
1855	0.081	D			0.106	D	119	6	125	8	36L60+
1856	0.089	D			0.098	D	94	5	75	5	36L60+
1857	0.092	D			0.102	D	86	5	95	6	36L60+
1858	0.084	D			0.103	D	105	5	121	6	36L60+
1859	0.103	D			0.099	D	133	8	141	13	36L60+
1900	0.088	D			0.100	D	141	10	145	11	36L60+
1901	0.086	D			0.096	D	137	8	126	8	36L60+
1902	0.083	D			0.102	D	142	7	139	9	M

12HR ARCHIVE

ASOS OID PRINTOUT FOLLOWS:

13:03:22 06/25/97 1903Z

MEMPHIS INTERNATIONAL ARPT

06/25/97 12:33 JMR 9999 JMR LOGGED OFF AS TECHNICIAN FROM OID#4
06/25/97 12:38 *ST 1406 RVR INOPERATIONAL
06/25/97 12:56 *ST 1407 RVR OPERATIONAL
06/25/97 13:02 *ST 1406 RVR INOPERATIONAL

MAINTENANCE LOG

ASOS OID PRINTOUT FOLLOWS:

13:03:36 06/25/97 1903Z

MEMPHIS INTERNATIONAL ARPT

SKY = CLR
VISIBILITY = 10SM
RVR = RVRNO
PRESENT WX=

TEMP/DEWPT = 31.1 /22.2 C 88 /72 F
WIND DIR/SPD = 150/09
ALTIMETER = 30.02

REMARKS = RMK A02 TSNO PNO

TESTM KMEM 251856Z AUTO VRB05KT 10SM CLR 31/22 A3002 RMK A02 SLP162
T03110217 TSNO PNO

MAG WIND DIR/SPD: 140/10

RELATIVE HUMIDITY: 58

SEA LVL PRESSURE: 1016.1

STATION PRESSURE: 29.70

PRESSURE ALTITUDE: 240

DENSITY ALTITUDE: 2200

RVR/ASOS INTERFACE TEST TROUBLE REPORT			TTR-006
DATE: 6/24/97	TIME: PM	SITE: MEM	
SYSTEMS/COMPONENTS IN ISSUE:			
RVR DPU <input checked="" type="checkbox"/>	RVR MDT <input type="checkbox"/>	ASOS ACU <input type="checkbox"/>	
RVR SIE <input checked="" type="checkbox"/>	INTERIM INTERFACE <input type="checkbox"/>	ASOS DISPLAY <input type="checkbox"/>	
RVR CD <input type="checkbox"/>	FINAL INTERFACE <input type="checkbox"/>	MPS <input type="checkbox"/>	
TEST EQUIPMENT USED:			
PROTOCOL ANALYZER <input type="checkbox"/>			
OTHER: MDT screens at DPU and SIE			
TEST PLAN ID:			
TEST PROCEDURE ID: A-2 STEP(S):			
DESCRIPTION OF ISSUE/PROBLEM: "Calibration Parameter Mismatch"			
It was noted that the "Rate of Change" limit parameter on the DPU did not match the same parameter on the VS SIE. A reset (Power on and off) was performed on the VS SIE to correct the mismatch.			
NEW GENERATION RVR SOFTWARE VERSION ID:			
ASOS SOFTWARE VERSION ID:			
Michael Jones			6/24/97
ISSUE/PROBLEM WITNESS		DATE	
Michael Jones			6/24/97
FAA TEST DIRECTOR/REPRESENTATIVE		DATE	
NWS REPRESENTATIVE		DATE	
NOAA REPRESENTATIVE		DATE	

RVR/ASOS INTERFACE TEST TROUBLE REPORT	TTR-008
---	---------

DATE: 6/23/97	TIME: AM	SITE: MEM
---------------	----------	-----------

SYSTEMS/COMPONENTS IN ISSUE:

RVR DPU <input type="checkbox"/>	RVR MDT <input type="checkbox"/>	ASOS ACU <input type="checkbox"/>
RVR SIE <input type="checkbox"/>	INTERIM INTERFACE <input type="checkbox"/>	ASOS DISPLAY <input type="checkbox"/>
RVR CD <input type="checkbox"/>	FINAL INTERFACE <input checked="" type="checkbox"/>	MPS <input type="checkbox"/>

TEST EQUIPMENT USED:
 PROTOCOL ANALYZER
 OTHER: N/A

TEST PLAN ID:

TEST PROCEDURE ID: **STEP(S):**

DESCRIPTION OF ISSUE/PROBLEM: "Blank Panel Removal"

Equipment Mod instructions do not include steps indicating how to remove the blank panel.

NEW GENERATION RVR SOFTWARE VERSION ID:

ASOS SOFTWARE VERSION ID:

Michael Jones	6/23/97
<i>ISSUE/PROBLEM WITNESS</i>	<i>DATE</i>

Michael Jones	6/23/97
<i>FAA TEST DIRECTOR/REPRESENTATIVE</i>	<i>DATE</i>

<i>NWS REPRESENTATIVE</i>	<i>DATE</i>
---------------------------	-------------

<i>NOAA REPRESENTATIVE</i>	<i>DATE</i>
----------------------------	-------------

RVR/ASOS INTERFACE TEST TROUBLE REPORT

TTR-010

DATE: 6/23/97

TIME: AM

SITE: MEM

SYSTEMS/COMPONENTS IN ISSUE: Equipment Modification Instructions

RVR DPU

RVR MDT

ASOS ACU

RVR SIE

INTERIM INTERFACE

ASOS DISPLAY

RVR CD

FINAL INTERFACE

MPS

TEST EQUIPMENT USED:

PROTOCOL ANALYZER

OTHER:

TEST PLAN ID:

TEST PROCEDURE ID:

STEP(S):

DESCRIPTION OF ISSUE/PROBLEM:

Instructions do not state that the lock washer should be place on screw before flat washer.

NEW GENERATION RVR SOFTWARE VERSION ID:

ASOS SOFTWARE VERSION ID:

Michael Jones

6/27/97

ISSUE/PROBLEM WITNESS

DATE

Michael Jones

6/27/97

FAA TEST DIRECTOR/REPRESENTATIVE

DATE

Peggy Marie Hoch

6/26/97

NWS REPRESENTATIVE

DATE

NOAA REPRESENTATIVE

DATE

RVR/ASOS INTERFACE TEST TROUBLE REPORT			TTR-014
DATE: 6/23/97	TIME: AM	SITE: MEM	
SYSTEMS/COMPONENTS IN ISSUE: Equipment Modification Instructions			
RVR DPU <input type="checkbox"/>	RVR MDT <input type="checkbox"/>	ASOS ACU <input type="checkbox"/>	
RVR SIE <input type="checkbox"/>	INTERIM INTERFACE <input type="checkbox"/>	ASOS DISPLAY <input type="checkbox"/>	
RVR CD <input type="checkbox"/>	FINAL INTERFACE <input checked="" type="checkbox"/>	MPS <input type="checkbox"/>	
TEST EQUIPMENT USED:			
PROTOCOL ANALYZER <input type="checkbox"/>			
OTHER:			
TEST PLAN ID:			
TEST PROCEDURE ID:		STEP(S):	
DESCRIPTION OF ISSUE/PROBLEM:			
Note missing in instructions indicating that the ASOS ID is the runway identifier for long line runway.			
NEW GENERATION RVR SOFTWARE VERSION ID:			
ASOS SOFTWARE VERSION ID:			
Michael Jones	6/23/97		
<i>ISSUE/PROBLEM WITNESS</i>		<i>DATE</i>	
Michael Jones	6/27/97		
<i>FAA TEST DIRECTOR/REPRESENTATIVE</i>		<i>DATE</i>	
Peggy Marie Hoch	6/26/97		
<i>NWS REPRESENTATIVE</i>		<i>DATE</i>	
NOAA REPRESENTATIVE		DATE	

RVR/ASOS INTERFACE TEST TROUBLE REPORT		TTR-015
DATE: 6/24/97	TIME: AM	SITE: MEM
SYSTEMS/COMPONENTS IN ISSUE:		
RVR DPU <input type="checkbox"/>	RVR MDT <input type="checkbox"/>	ASOS ACU <input type="checkbox"/>
RVR SIE <input type="checkbox"/>	INTERIM INTERFACE <input type="checkbox"/>	ASOS DISPLAY <input type="checkbox"/>
RVR CD <input type="checkbox"/>	FINAL INTERFACE <input checked="" type="checkbox"/>	MPS <input type="checkbox"/>
TEST EQUIPMENT USED:		
PROTOCOL ANALYZER <input type="checkbox"/>		
OTHER:		
TEST PLAN ID:		
TEST PROCEDURE ID: STEP(S):		
DESCRIPTION OF ISSUE/PROBLEM:		
Sites transitioning from the interim interface to final interface will require a cable mod or EIA-530 null modem adapter to be inserted on the RVR ASOS connector.		
NEW GENERATION RVR SOFTWARE VERSION ID:		
ASOS SOFTWARE VERSION ID:		
Michael Jones	6/24/97	
ISSUE/PROBLEM WITNESS	DATE	
Michael Jones	6/24/97	
FAA TEST DIRECTOR/REPRESENTATIVE	DATE	
Peggy Marie Hoch	6/26/97	
NWS REPRESENTATIVE	DATE	
NOAA REPRESENTATIVE	DATE	

RVR/ASOS INTERFACE TEST TROUBLE REPORT		TTR-017
DATE: 6/26/97	TIME: 9:45AM	SITE: MEM
SYSTEMS/COMPONENTS IN ISSUE:		
RVR DPU <input type="checkbox"/>	RVR MDT <input type="checkbox"/>	ASOS ACU <input checked="" type="checkbox"/>
RVR SIE <input type="checkbox"/>	INTERIM INTERFACE <input type="checkbox"/>	ASOS DISPLAY <input checked="" type="checkbox"/>
RVR CD <input type="checkbox"/>	FINAL INTERFACE <input checked="" type="checkbox"/>	MPS <input type="checkbox"/>
TEST EQUIPMENT USED:		
PROTOCOL ANALYZER <input type="checkbox"/>		
OTHER: N/A		
TEST PLAN ID:		
TEST PROCEDURE ID: p. A.2-53		STEP(S):
DESCRIPTION OF ISSUE/PROBLEM:		
While running test procedures for RVR, changed baud rate of RVR to 19200 from 2400.		
Saw "RVRNO" on 1 minute screen but no "RVR Inoperational" message in SYSLOG.		
After changing baud rate back to 2400 required 10 readings to get RVR field to come back with numeric values rather than RVRNO (should be 8). Repeat test and documented.		
NEW GENERATION RVR SOFTWARE VERSION ID:		
ASOS SOFTWARE VERSION ID:		
Peggy Marie Hoch	6/26/97	
ISSUE/PROBLEM WITNESS	DATE	
Mike McKinney	6/26/97	
FAA TEST DIRECTOR/REPRESENTATIVE	DATE	
Peggy Marie Hoch	6/26/97	
NWS REPRESENTATIVE	DATE	
NOAA REPRESENTATIVE	DATE	

06/25/97 13:14 *ST 1407 RVR OPERATIONAL

06/25/97 13:27 *ST 1406 RVR INOPERATIONAL

06/25/97 13:38 *ST 1407 RVR OPERATIONAL

PMH LOGGED OFF AS SYSTEM MANAGER FROM OID#1 ON 06/25/97 AT 13:50:01

PMH LOGGED ON AS TECHNICIAN FROM OID#1 ON 06/25/97 AT 13:50:01

PMH LOGGED OFF AS TECHNICIAN FROM OID#1 ON 06/25/97 AT 14:04:30

PMH LOGGED ON AS OBSERVER FROM OID#1 ON 06/25/97 AT 14:04:30

06/25/1997 14:16 EDIT-ENTRY KMEM 252016Z 17007KT SCT044 32/22 A3000 RMK A02 PN \$ (PMH)

06/25/1997 14:17 EDIT-EXIT KMEM 252017Z 17007KT FEW044 32/22 A3000 RMK A02 PNO \$ (PMH)

06/25/1997 14:18 EDIT-ENTRY KMEM 252018Z VRB05KT FEW044 31/22 A3000 RMK A02 PN \$ (PMH)

06/25/1997 14:19 EDIT-EXIT KMEM 252019Z VRB05KT R36L/2000FT FEW044 31/22 A3000 RMK A02 PNO \$ (PMH)

06/25/1997 14:26 EDIT-ENTRY KMEM 252026Z 17010KT R36L/2000FT FEW044 SCT065 32/22 A3000 RMK A02 PNO \$ (PMH)

06/25/1997 14:27 EDIT-EXIT KMEM 252027Z 17009KT FEW044 SCT065 32/22 A3000 RMK A02 PNO \$ (PMH)

PMH LOGGED OFF AS OBSERVER FROM OID#1 ON 06/25/97 AT 14:35:00

PMH LOGGED ON AS TECHNICIAN FROM OID#1 ON 06/25/97 AT 14:35:00

PMH LOGGED OFF AS TECHNICIAN FROM OID#1 ON 06/25/97 AT 14:41:34

06/25/97 14:45 *ST 1406 RVR INOPERATIONAL

06/25/97 14:46 *ST 1407 RVR OPERATIONAL

06/25/97 15:11 *ST 1406 RVR INOPERATIONAL

06/25/97 15:13 *ST 1407 RVR OPERATIONAL

06/25/97 15:18 *ST 1406 RVR INOPERATIONAL

06/25/97 15:22 *ST 1407 RVR OPERATIONAL

PMH LOGGED ON AS SYSTEM MANAGER FROM OID#1 ON 06/25/97 AT 16:07:33

06/25/97 16:13 *ST 0523 ACU SIO #1 PORT #3 TRANSMISSION ERROR (REPLACE)

06/25/97 16:26 *ST 1407 RVR OPERATIONAL

NEEDED 10 READINGS TO GET THIS 

ASOS OID PRINTOUT FOLLOWS:

RECREATION OF PROBLEM

PMH LOGGED ON AS SYSTEM MANAGER FROM OID#1 ON 06/26/97 AT 08:11:20

ASOS OID PRINTOUT FOLLOWS:

08:11:58 06/26/97 1411Z

MEMPHIS INTERNATIONAL ARPT

PORT MOD FUNCTION		PORT MOD FUNCTION	PORT MOD FUNCTION
1-1		4-1	UPS
2		2	PRESSURE #3
3	RVR	3 7	VDU-1
4		4	
2-1	ACU-DCP A	5-1 2	OID-2 SECONDARY
2	PRESSURE#1	2	PRINTER
3 4	OID-4USER	3	VDU-2
4	VOICE	4 8	VDU-3
3-1	ACU-DCP B		
2	PRESSURE #2		
3 5	OID-5 USER #2		
4	OID-1 LOCAL		

	FUNCTION RVR		
STATUS	ENABLED	HANDSHAKE	NONE ACU SERIAL COMMS
BAUD RATE	2400	CONNECTION	HARD-WIRE
PARITY SELECT	EVEN		
BITS/CHAR	7		
STOP BITS	1		

ASOS OID PRINTOUT FOLLOWS:

08:12:22 06/26/97 1412Z

MEMPHIS INTERNATIONAL ARPT

PORT MOD FUNCTION		PORT MOD FUNCTION	PORT MOD FUNCTION
1-1		4-1	UPS
2		2	PRESSURE #3
3	RVR	3 7	VDU-1
4		4	
2-1	ACU-DCP A	5-1 2	OID-2 SECONDARY
2	PRESSURE#1	2	PRINTER
3 4	OID-4USER#1	3	VDU-2
4	VOICE	4 8	VDU-3
3-1	ACU-DCP B		
2	PRESSURE #2		
3 5	OID-5 USER #2		
4	OID-1 LOCAL		

	FUNCTION RVR		
STATUS	ENABLED	HANDSHAKE	NONE ACU SERIAL COMMS
BAUD RATE	19200	CONNECTION	HARD-WIRE
PARITY SELECT	EVEN		
BITS/CHAR	7		
STOP BITS	1		CHANGED FROM 2400 TO 19200

LOGGED OFF AS SYSTEM MANAGER FROM OID#1 ON 06/26/97 AT 08:12:52

ASOS OID PINTOUT FOLLOWS:

08:13:02 06/26/97 1413Z

MEMPHIS INTERNATIONAL ARPT

SKY	= MM	TEMP/DEWPT	= 25.0 /21.1 C 77 /770 F
VISIBILITY	= 10SM	WIND DIR/SPD	= 000/00
RVR	= RVRNO	ALTIMETER	= 30.07
PRESENT WX=			

REMARKS = RMK A02 TSNO PNO **SAW THIS BUT NO SYSLOG MESSAGE**

MAG WIND DIR/SPD:	000/00	STATION PRESSURE:	29.76
RELATIVE HUMIDITY:	79	PRESSURE ALTITUDE:	190
SEA LVL PRESSURE:	1017.9	DENSITY ALTITUDE:	1400

ASOS OID PRINTOUT FOLLOWS:

08:13:30 06/26/97 1413Z

MEMPHIS INTERNATIONAL ARPT

06/26/97 08:09 *ST 1407 RVR OPERATIONAL

06/26/97 08:10 PMH 9999 PMH LOGGED OFF AS SYSTEM MANAGER FROM OID#1

06/26/97 08:11 PMH 9999 PMH LOGGED ON AS SYSTEM MANAGER FROM OID#1

06/26/97 08:12 PMH 9999 PMH LOGGED OFF AS SYSTEM MANAGER FROM OID#1

MAINTENANCE LOG

08/26/97 08:18 *ST 0523 ACU SIO #1 PORT #3 TRANSMISSION ERROR (REPLACE)

ASOS OID PRINTOUT FOLLOWS:

08:18:29 06/26/97 1418Z

MEMPHIS INTERNATIONAL ARPT

UTC	VIS1	D/N1	VIS2	D/N2	VIS3	D/N3	WIND	DIR/SPD	5SEC	WIND	RVR
1407	0.148	D			0.142	D	311	1	1	1	36L60+
1408	0.147	D			0.138	D	340	1	20	1	36L60+
1409	0.146	D			0.144	D	348	1	263	1	36L60+
1410	0.144	D			0.137	D	328	2	285	3	36L60+
1411	0.134	D			0.133	D	284	2	251	3	36L60+
1412	0.123	D			0.127	D	257	2	247	3	36L60+
1413	0.115	D			0.129	D	245	2	262	2	36L60+
1414	0.114	D			0.128	D	249	2	243	2	M
1415	0.110	D			0.129	D	243	1	197	1	M
1416	0.111	D			0.131	D	234	1	226	1	M
1417	0.107	D			0.134	D	217	0	143	1	M
1418	0.105	D			0.125	D	258	1	279	1	M

12HR ARCHIVE

PMH LOGGED ON AS SYSTEM MANAGER FROM OID#1 ON 06/26/97 AT 08:18:58.

ASOS OID PRINTOUT FOLLOWS:

08:19:32 06/26/97 1419Z

MEMPHIS INTERNATIONAL ARPT

PORT MOD FUNCTION	PORT MOD FUNCTION	PORT MOD FUNCTION
1-1	4-1	UPS
2	2	PRESSURE #3
3	3 7	VDU-1
4	4	
2-1	5-1 2	OID-2 SECONDARY
2	2	PRINTER
3 4	3	VDU-2
4	4 8	VDU-3
3-1		
2		
3 5		
4		

	FUNCTION RVR		
STATUS	ENABLED	HANDSHAKE	NONE ACU SERIAL COMMS
BAUD RATE	2400	CONNECTION	HARD-WIRE
PARITY SELECT	EVEN		
BITS/CHAR	7		
STOP BITS	1	RESTORED BAUD RATE	

ASOS OID PRINTOUT FOLLOWS:

08:28:30 06/26/97 1428Z

MEMPHIS INTERNATIONAL ARPT

UTC	VIS1	D/N1	VIS2	D/N2	VIS3	D/N3	WIND	DIR/SPD	5SEC	WIND	RVR
1417	0.107	D			0.134	D	217	0	143	1	M
1418	0.105	D			0.125	D	258	1	279	1	M
1419	0.097	D			0.129	D	292	1	278	1	M
1420	0.097	D			0.131	D	253	2	226	4	36L60+
1421	0.101	D			0.120	D	232	3	222	4	36L60+
1422	0.103	D			0.118	D	228	3	244	5	36L60+
1423	0.098	D			0.120	D	241	4	249	4	36L60+
1424	0.095	D			0.118	D	245	3	243	3	36L60+
1425	0.098	D			0.114	D	256	3	289	4	36L60+
1426	0.098	D			0.119	D	290	4	322	4	36L60+
1427	0.091	D			0.122	D	317	4	308	5	36L60+
1428	0.095	D			0.117	D	315	4	331	4	36L60+

12HR ARCHIVE

AFTER 9 READINGS, STILL NO RVR

ASOS OID PRINTOUT FOLLOWS:

08:28:47 06/26/97 1428Z

MEMPHIS INTERNATIONAL ARPT

SKY	= MM	TEMP/DEWPT	= 26.1 /22.2 C 79 /72 F
VISIBILITY	= 10SM	WIND DIR/SPD	= 320/04
RVR	= RVRNO	ALTIMETER	= 30.07
PRESENT WX	=		

REMARKS = RMK A02 TSNO PNO

MAG WIND DIR/SPD: 310/04

RELATIVE HUMIDITY: 79

SEA LVL PRESSURE: 1017.9

STATION PRESSURE: 29.76

PRESSURE ALTITUDE: 190

DENSITY ALTITUDE: 1600

06/26/97 08:29 *ST 1407 RVR OPERATIONAL

AFTER 10 READINGS

ASOS OID PRINTOUT FOLLOWS:

08/29/11: 06/26/97 1429Z

MEMPHIS INTERNATIONAL ARPT

06/26/97 08:12 PMH 9999 PMH LOGGED OFF AS SYSTEM MANGER FROM OID#1

06/26/97 08:18 *ST 0523 ACU SIO #1 PORT #3 TRANSMISSION ERROR (REPLACE)

06/26/97 08:18 PMH 9999 PMH LOGGED ON AS SYSTEM MANAGER FROM OID#1

06/26/97 08:29 *ST 1407 RVR OPERATIONAL

MAINTENANCE LOG

ASOS OID PRINTOUT FOLLOWS:

08:29:26 06/26/97 1429Z

MEMPHIS INTERNATIONAL ARPT

SKY	= MM	TEMP/DEWPT	= 26.1 /22.2 C 79 /72 F
VISIBILITY	= 10SM	WIND DIR/SPD	= 310/03
RVR	= R36L/P6000FT	ALTIMETER	= 30.07
PRESENT WX	=		

REMARKS = RMK A02 TSNO PNO

MAG WIND DIR/SPD: 310/03

RELATIVE HUMIDITY: 79

SEA LVL PRESSURE: 1017.9

STATION PRESSURE: 29.76

PRESSURE ALTITUDE: 190

DENSITY ALTITUDE: 1600

ASOS OID PRINTOUT FOLLOWS:

08:29:42 06/26/97 1429Z

MEMPHIS INTERNATIONAL ARPT

UTC	VIS1	D/N1	VIS2	D/N2	VIS3	D/N3	WIND	DIR/SPD	5SEC	WIND	RVR
1418	0.105	D			0.125	D	258	1	279	1	M
1419	0.097	D			0.129	D	292	1	278	1	M
1420	0.097	D			0.131	D	253	2	226	4	36L60+
1421	0.101	D			0.120	D	232	3	222	4	36L60+
1422	0.103	D			0.118	D	228	3	244	5	36L60+
1423	0.098	D			0.120	D	241	4	249	4	36L60+
1424	0.095	D			0.118	D	245	3	243	3	36LFFF
1425	0.098	D			0.114	D	256	3	289	4	36L60+
1426	0.098	D			0.119	D	290	4	322	4	36L60+
1427	0.091	D			0.122	D	317	4	308	5	36L60+
1428	0.095	D			0.117	D	315	4	331	4	36L60+
1429	0.102	D			0.118	D	311	3	309	4	36L60+

12HR ARCHIVE

RVR OPERATIONAL MESSAGE RECORDED AT 08:29 (1429Z)

06/26/97 08:30 *ST 2752 CEILOMETER #1 IS OPERATIVE

06/26/97 08:30 *ST 2754 CEILOMETER #3 IS OPERATIVE

ASOS OID PRINTOUT FOLLOWS:

08:30:15 06/26/97 1430Z

MEMPHIS INTERNATIONAL ARPT

06/26/97 07:55:31 5-MIN KMEM 261355Z AUTO 24003KT 24/21 A3007 200 84 1300
240/03 RMK A02 SLP178 T02390211 TSNO RVRNO PNO \$

06/26/97 08:00:31 5-MIN KMEM 261400Z AUTO M M M M /M RMK A02 FZRANO TSNO
RVRNO PNO \$

06/26/97 08:05:31 5-MIN KMEM 261405Z AUTO 00000KT 24/21 A3007 190 81 1400
000/00 RMK A02 TSNO RVRNO PNO \$

06/26/97 08:10:31 5-MIN KMEM 261410Z AUTO 00000KT 10SM R36L/P6000FT 25/21
A3007 200 79 1400 000/00 RMK A02 TSNO PNO \$

06/26/97 08:15:31 5-MIN KMEM 261415Z AUTO 00000KT 10SM 25/21 A3007 200 79
1400 000/00 RMK A02 TSNO PNO \$

06/26/97 08:20:31 5-MIN KMEM 261420Z AUTO 00000KT 10SM 26/22 A3007 200 79
1500 000/00 RMK A02 TSNO PNO \$

06/26/97 08:25:31 5-MIN KMEM 261425Z AUTO VRB03KT 10SM 26/22 A3007 190 79
1600 VRB/03 RMK A02 TSNO PNO \$

REVIEW 5 MINUTE

RVR/ASOS INTERFACE TEST TROUBLE REPORT	TTR-018
---	---------

DATE: 6/26/97	TIME: 11:17AM	SITE: MEM
---------------	---------------	-----------

SYSTEMS/COMPONENTS IN ISSUE:

RVR DPU <input type="checkbox"/>	RVR MDT <input type="checkbox"/>	ASOS ACU <input checked="" type="checkbox"/>
RVR SIE <input type="checkbox"/>	INTERIM INTERFACE <input type="checkbox"/>	ASOS DISPLAY <input checked="" type="checkbox"/>
RVR CD <input type="checkbox"/>	FINAL INTERFACE <input checked="" type="checkbox"/>	MPS <input type="checkbox"/>

TEST EQUIPMENT USED:
 PROTOCOL ANALYZER
 OTHER: N/A

TEST PLAN ID:
TEST PROCEDURE ID: p. A.2-53 **STEP(S):**

DESCRIPTION OF ISSUE/PROBLEM:

Sent a bad block check code from RVR to ASOS. Got RVRNO and missing data for at least 11 minutes but SYSLOG showed only "RVR Inoperational" message not a transmission error message as expected.

With numeric values rather than RVRNO. (should be 8). Repeat test and documented.

NEW GENERATION RVR SOFTWARE VERSION ID:
ASOS SOFTWARE VERSION ID: V2.47

Peggy Marie Hoch	6/26/97
ISSUE/PROBLEM WITNESS	DATE

Michael Jones	6/26/97
FAA TEST DIRECTOR/REPRESENTATIVE	DATE

Peggy Marie Hoch	6/26/97
NWS REPRESENTATIVE	DATE

NOAA REPRESENTATIVE	DATE

SENT BAD BLOCK CHECK CODE P A.3-23

ASOS OID PRINTOUT FOLLOWS:

10:13:04 06/26/97 1613ZZ

MEMPHIS INTERNATIONAL ARPT

SKY	= CLR	TEMP/DEWPT	= 27.8 /20.0 C 82 /68 F
VISIBILITY	= 1/2SM	WIND DIR/SPD	= 190/03
RVR	= RVRNO	ALTIMETER	= 30.09
PRESENT WX	= HZ		

REMARKS = RMK A02 TSNO RVRNO PNO

TESTM KMEM 261556Z AUTO 25004KT 1/2SM R18/P6000FT HZ CLR 28/22 A3009
RMK A02 SLP183 TO2780217 TSNO PNO \$

MAG WIND DIR/SPD: VRB/03

RELATIVE HUMIDITY: 62 STATION PRESSURE: 29.77

PRESSURE ALTITUDE: 180

SEA LVL PRESSURE: 1018.3

DENSITY ALTITUDE: 1700

ASOS OID PRINTOUT FOLLOWS:

10:13:17 06/26/97 1613Z

MEMPHIS INTERNATIONAL ARPT

06/26/97 10:04 JMR 9999 CLEARED 1 DATA QUALITY ERROR ON CEILOMETER #1.

06/26/97 10:05 *ST 1406 RVR INOPERATIONAL

06/26/97 10:06 JMR 9999 CLEARED 1 DATA QUALITY ERROR ON CEILOMETER #3.

06/26/97 10:08 JMR 9999 JMR LOGGED OFF AS TECHNICIAN FROM OID#4.

ASOS OID PRINTOUT FOLLOWS:

10:13:38 06/26/97 1613Z

UTC	VIS1	D/N1	VIS2	D/N2	VIS3	D/N3	WIND	DIR/SPD	5SEC	WIND	RVR
1602	0.103	D			0.149	D	219	3	203	4	18.60+
1603	0.098	D			0.146	D	207	3	188	4	M
1604	0.099	D			0.147	D	204	3	169	3	M
1605	0.102	D			0.154	D	226	3	234	5	M
1606	0.127	D			0.146	D	251	4	269	5	M
1607	0.111	D			0.144	D	256	5	251	6	M
1608	0.112	D			0.140	D	244	5	227	6	M
1609	0.116	D			0.143	D	231	5	229	6	M
1610	0.109	D			0.153	D	216	4	195	4	M
1611	0.103	D			0.150	D	201	3	198	4	M
1612	0.106	D			0.158	D	191	3	185	3	M
1613	0.102	D			0.153	D	195	3	224	4	M

12HR ARCHIVE

ASOS OID PRINTOUT FOLLOWS:

10:13:57 06/26/97 1613Z

MEMPHIS INTERNATIONAL ARPT

1 MINUTE CURRENT SENSOR DATA

UTC	VIS1	D/N1	VIS2	D/N2	VIS3	D/N3	TEMP	DEWPT	5SEC	WIND	RVR
1604	10.00	D			10.00	D	82	71	169	3	M
1605	10.00	D			10.00	D	82	70	234	5	M
1606	10.00	D			10.00	D	82	70	269	5	M
1607	10.00	D			10.00	D	82	69	251	6	M
1608	10.00	D			10.00	D	82	70	227	6	M
1609	10.00	D			10.00	D	82	68	229	6	M
1610	10.00	D			10.00	D	82	65	195	4	M
1611	10.00	D			10.00	D	82	68	198	4	M
1612	10.00	D			10.00	D	82	70	185	3	M
1613	10.00	D			10.00	D	82	72	224	4	M

CURRENT

PRECIPITATION AMOUNT (HOUR): M IN
 WATER EQUIVALENT (HOUR): M IN
 CURRENT SNOW DEPTH: M IN

DID NOT SEE A TRANSMISSION ERROR IN THE LOG AND SIO PORT NEVER FAILED

RVR/ASOS INTERFACE TEST TROUBLE REPORT

TTR-019

DATE: 6/26/97	TIME: 11:35AM	SITE: MEM
SYSTEMS/COMPONENTS IN ISSUE:		
RVR DPU <input type="checkbox"/>	RVR MDT <input checked="" type="checkbox"/>	ASOS ACU <input type="checkbox"/>
RVR SIE <input type="checkbox"/>	INTERIM INTERFACE <input checked="" type="checkbox"/>	ASOS DISPLAY <input type="checkbox"/>
RVR CD <input checked="" type="checkbox"/>	FINAL INTERFACE <input type="checkbox"/>	MPS <input type="checkbox"/>
TEST EQUIPMENT USED:		
PROTOCOL ANALYZER <input type="checkbox"/>		
OTHER:		
TEST PLAN ID:		
TEST PROCEDURE ID: A.3-20 STEP(S):		
DESCRIPTION OF ISSUE/PROBLEM:		
Sent parity errors to ASOS from RVR. RVR stayed operational and did not see any missing data in either 12-HR or 1-MIN current data screens (Parity errors sent for at least 10 minutes).		
NEW GENERATION RVR SOFTWARE VERSION ID:		
ASOS SOFTWARE VERSION ID: V2.47		
Peggy Marie Hoch	6/26/97	
ISSUE/PROBLEM WITNESS	DATE	
Michael Jones	6/26/97	
FAA TEST DIRECTOR/REPRESENTATIVE	DATE	
Peggy Marie Hoch	6/26/97	
NWS REPRESENTATIVE	DATE	
NOAA REPRESENTATIVE	DATE	

SENT PARITY ERROR AT 10:24

06:26:97 10:29 *ST 0523 ACU SIO #1 PORT #3 TRANSMISSION ERROR (REPLACE)

ASOS OID PRINTOUT FOLLOWS:

10:29:24 06/26/97 1629Z

MEMPHIS INTERNATIONAL ARPT

06/26/97 10:21 *ST 1407 RVR OPERATIONAL

06/26/97 10:21 PMH 9999 PMH LOGGED OFF AS TECHNICIAN FROM OID#1

06/26/97 10:27 PMH 9999 PMH LOGED ON AS TECHNICIAN FROM OID#1

06/26/97 10:29 *ST 0523 ACU SIO #1 PORT #3 TRANSMISSION ERROR (REPLACE)

MAINTENANCE LOG

RVR KEPT REPORTING

ASOS OID PRINTOUT FOLLOWS:

10:29:39 06/26/97 1629Z

MEMPHIS INTERNATIONAL ARPT

SKY	= CLR	TEMP/DEWPT	= 28.3 /21.1 C 83 /70 F
VISIBILITY	= 1/2SM	WIND DIR/SPD	= 200/06
RVR	= R18/P6000FT	ALTIMETER	= 30.08
PRESENT WX	= HZ		

REMARKS = RMK A02 TSNO PNO

TESTM KMEM 261556Z AUTO 25004KT 1/2SM R18/P6000FT HZ CLR 28/22 A3009
RMK A02 SLP183 TO2780217 TSNO PNO \$

MAG WIND DIR/SPD: 200/06

RELATIVE HUMIDITY: 64

SEA LVL PRESSURE: 1018.2

STATION PRESSURE: 29.77

PRESSURE ALTITUDE: 180

DENSITY ALTITUDE: 1800

ASOS OID PRINTOUT FOLLOWS:

10:30:20 06/26/97 1630Z

MEMPHIS INTERNATIONAL ARPT

1 MINUTE CURRENT SENSOR DATA

UTC	VIS1	D/N1	VIS2	D/N2	VIS3	D/N3	TEMP	DEWPT	5SEC	WIND	RVR
1621	10.00	D			10.00	D	83	68	231	2	18 60+
1622	10.00	D			10.00	D	84	70	243	4	18 60+
1623	10.00	D			10.00	D	83	70	228	3	18 60+
1624	10.00	D			10.00	D	84	71	207	5	18 60+
1625	10.00	D			10.00	D	83	70	289	6	18 60+
1626	10.00	D			10.00	D	83	70	292	5	18 60+
1627	10.00	D			10.00	D	83	70	189	6	18 60+
1628	10.00	D			10.00	D	84	71	192	8	18 60+
1629	10.00	D			10.00	D	84	70	196	7	18 60+
1630	10.00	D			10.00	D	83	71			

CURRENT

PRECIPITATION AMOUNT (HOUR): M IN
 WATER EQUIVALENT (HOUR): M IN
 CURRENT SNOW DEPTH: M IN

NO MISSINGS SEEN

ASOS OID PRINTOUT FOLLOWS:

10:30:37 06/26/97 1630Z

MEMPHIS INTERNATIONAL ARPT

UTC	VIS1	D/N1	VIS2	D/N2	VIS3	D/N3	WIND	DIR/SPD	5SEC	WIND	RVR
1619	0.106	D			0.146	D	242	3	286	4	18 60+
1620	0.110	D			0.152	D	252	4	254	5	18 60+
1621	0.110	D			0.145	D	252	3	231	2	18 60+
1622	0.113	D			0.144	D	239	2	243	4	18 60+
1623	0.119	D			0.150	D	234	3	228	3	18 60+
1624	0.116	D			0.144	D	226	3	207	5	18 60+
1625	0.111	D			0.133	D	214	4	289	6	18 60+
1626	0.111	D			0.136	D	245	4	292	5	18 60+
1627	0.106	D			0.136	D	239	4	189	6	18 60+
1628	0.104	D			0.138	D	199	5	192	8	18 60+
1629	0.100	D			0.140	D	196	6	196	7	18 60+
1630	0.109	D			0.139	D	196	6	213	6	18 60+

12 HR ARCHIVE

ASOS OID PRINTOUT FOLLOWS:

10:31:07 06/26/97 1631Z

MEMPHIS INTERNATIONAL ARPT

06/26/97 10:00:31 5-MIN KMEM 261600Z AUTO 26004KT 1/2SM R18/P6000FT HZ
CLR

28/21 A3009 180 66 1700 260/04 RMK A02 TSNO PNO \$

06/26/97 10:05:31 5-MIN KMEM 261605Z AUTO VRB03KT 1/2SM R18/P6000FT HZ
CLR 28/21 A3008 180 66 1700 VRB/03 RMK A02 RVRNO PNO

06/26/97 10:10:31 5-MIN KMEM 261610Z AUTO VRB04KT 1/2SM HZ CLR 28/20
A3009 180 62 1700 VRB/04 RMK A02 TSNO RVRNO PNO

06/26/97 10:15:31 5-MIN KMEM 261605Z AUTO 22004KT 1/2SM HZ CLR 28/21 A3008
180 66 1700 220/04 RMK A02 TSNO RVRNO PNO

06/26/97 10:20:31 5-MIN KMEM 261620Z AUTO VRB04KT 1/2SM HZ CLR 28/21 A3009
180 64 1800 VRB/04 RMK A02 TSNO RVRNO PNO

06/26/97 10:25:31 5-MIN KMEM 261625Z AUTO VRB04KT 1/2SM R18/P6000FT HZ
CLR 28/21 A3008 180 64 1800 VRB/04 RMK A02 TSNO PNO

06/26/97 10:30:31 5-MIN KMEM 261630Z AUTO 20006KT 1/2SM R18/P6000FT HZ CLR
28/21 A3008 180 64 1800 200/06 RMK A02 TSNO PNO

REVIEW 5 MINUTE

RVR/ASOS INTERFACE TEST TROUBLE REPORT			TTR-020
DATE: 6/26/97	TIME: 19352	SITE: MEM	
SYSTEMS/COMPONENTS IN ISSUE:			
RVR DPU <input type="checkbox"/>	RVR MDT <input type="checkbox"/>	ASOS ACU <input checked="" type="checkbox"/>	
RVR SIE <input type="checkbox"/>	INTERIM INTERFACE <input type="checkbox"/>	ASOS DISPLAY <input checked="" type="checkbox"/>	
RVR CD <input type="checkbox"/>	FINAL INTERFACE <input type="checkbox"/>	MPS <input type="checkbox"/>	
TEST EQUIPMENT USED:			
PROTOCOL ANALYZER <input type="checkbox"/>			
OTHER:			
TEST PLAN ID:			
TEST PROCEDURE ID:		STEP(S):	
DESCRIPTION OF ISSUE/PROBLEM:			
While testing the threshold for specials the ASOS generated a special immediately			
going up through the threshold to 60+. However, on the way down through the threshold			
it took 10 readings below 2400 before a special was ever generated.			
NEW GENERATION RVR SOFTWARE VERSION ID:			
ASOS SOFTWARE VERSION ID: V2.47			
Peggy Marie Hoch		6/26/97	
ISSUE/PROBLEM WITNESS		DATE	
Michael Jones		6/26/97	
FAA TEST DIRECTOR/REPRESENTATIVE		DATE	
Peggy Marie Hoch		6/26/97	
NWS REPRESENTATIVE		DATE	
NOAA REPRESENTATIVE		DATE	

ASOS OID PRINTOUT FOLLOWS:

13:28:39 06/26/97 1928Z

MEMPHIS INTERNATIONAL ARPT

SKY = SCT031 TEMP/DEWPT = 30.6/23.9 C87/75
 F
 VISIBILITY = 1/2SM WIND DIR/SPD = VRB/06
 RVR = R36L/0200VP6000FT ALTIMETER = 30.04
 PRESENT WX = HZ
 REMARKS = RMK A02 PNO

TESTM KMEM 261922Z 25007KT 1/2SM R36L/1600VP6000FT HZ FEW031 31/24 A3004
 RMK A02 PNO

MAG WIND DIR/SPD: VRB/06

RELATIVE HUMIDITY: 67 STATION PRESSURE: 29.72

PRESSURE ALTITUDE: 230

SEA LVL PRESSURE: 1016.7 DENSITY ALTITUDE: 2100

ASOS OID PRINTOUT FOLLOWS:

13:29:00 06/26/97 1929Z

MEMPHIS INTERNATIONAL ARPT

UTC	VIS1	D/N1	VIS2	D/N2	VIS3	D/N3	WIND	DIR/SPD	5SEC	WIND	RVR
1917	0.206	D			0.203	D	254	5	277	5	36L60+
1918	0.211	D			0.212	D	260	4	273	5	36L60+
1919	0.216	D			0.208	D	243	5	247	8	36L60+
1920	0.219	D			0.207	D	236	5	278	6	36L60+
1921	0.215	D			0.206	D	245	5	250	8	36L60+
1922	0.208	D			0.204	D	249	7	258	9	36L60+
1923	0.210	D			0.204	D	260	8	252	9	36L60+
1924	0.205	D			0.208	D	273	7	266	8	36L60+
1925	0.210	D			0.205	D	294	5	311	6	36L50
1926	0.211	D			0.194	D	304	5	319	5	36L57
1927	0.222	D			0.191	D	313	5	328	7	36L10
1928	0.220	D			0.191	D	301	6	264	6	36L02

12HR ARCHVIE

SHOULD HAVE SEEN A SPECIAL HERE BUT DID NOT

ASOS OID PRINTOUT FOLLOWS:

13:29:22 06/26/97 1929Z

MEMPHIS INTERNATIONAL ARPT

1-MINUTE CURRENT SENSOR DATA

UTC	VIS1	D/N1	VIS2	D/N2	VIS3	D/N3	TEMP	DEWPT	5SEC	WIND	RVR
1920	8.51	D			9.01	D	87	75	278	6	36L60+
1921	8.67	D			9.05	D	87	75	250	8	36L60+
1922	8.96	D			9.14	D	87	75	258	9	36L60+
1923	8.88	D			9.14	D	86	75	252	9	36L60+
1924	9.09	D			8.96	D	86	75	266	8	36L60+
1925	8.88	D			9.09	D	87	75	311	6	36L50
1926	8.83	D			9.61	D	87	74	319	5	36L57
1927	8.40	D			9.76	D	88	76	328	7	36L10
1928	8.47	D			9.76	D	87	74	264	6	36L02
1929	8.40	D			9.41	D	86	74			36L03

CURRENT

PRECIPITATION AMOUNT (HOUR): M IN
WATER EQUIVALENT (HOUR): M IN
CURRENT SNOW DEPTH: M IN

ASOS OID PRINTOUT FOLLOWS:

13:29:47 06/26/97 1929Z

MEMPHIS INTERNATIONAL ARPT

06/26/97 11:56:26 TESTM KMEM 261756Z AUTO 28005KT 10SM FEW025 BKN048
29/23 A3006 RMK A02 SLP176 6//// T02940233 10294 20211 58004 TSNO PNO
06/26/97 12:37:26 TESTS KMEM 261837Z AUTO VRB06KT 10SM R18/5000VP6000FT
BKN029 BKN036 BKN042 29/24 A3006 RMK A02 T5SNO PNO
06/26/97 12:44:26 TESTS KMEM 261844Z AUTO VRB06KT 10SM R18/5000VP6000FT
SCT029 BKN039 29/24 A3006 RMK A02 TSNO PNO \$
06/26/97 12:56:26 TESTM KMEM 261856Z AUTO 25007KT 210V280 10SM
R36L/5000VP6000FT FEW029 SCT038 29/24 A3005 RMK A02 BSLP170 T02940239 TSNO
PNO
06/26/97 13:09:10 PMH LOGGED ON AS OBSERVER FROM OID#1
06/26/97 13:15:26 TESTS KMEM 261915Z 25007KT 1/2SM R36L/0200V2200FT HZ
FEW031 31/24 A3004 RMK A02 PNO (PMH)
06/26/97 13:22:26 TESTS KMEM 261922Z 25007KT 1/2SM R36L/1600VP6000FT HZ
FEW031 31/24 A3004 RMK A02 PNO (PMH)

REVIEW OBSERVATION

GOING UP THROUGH 2400FT GENERATED THIS SPECIAL IMMEDIATELY!!!

ASOS OID PRINTOUT FOLLOWS:

13:36:55 06/26/97 1936Z ***SPECIAL*** MEMPHIS INTERNATIONAL ARPT

SKY = FEW031 TEMP/DEWPT = 30.0/23.3 C86/74
 F
 VISIBILITY = 1/2SM WIND DIR/SPD = VRB/04
 RVR = R36L/0200V2200FT ALTIMETER = 30.04
 PRESENT WX = HZ

REMARKS = RMK A02 PNO

TESTM KMEM 261936Z VRB04KT 1/2SM R36L/0200V2200FT HZ FEW031 30/23 A3004
 RMK A02 PNO

MAG WIND DIR/SPD: 230/04

RELATIVE HUMIDITY: 67 STATION PRESSURE: 29.72

PRESSURE ALTITUDE: 230

SEA LVL PRESSURE: 1016.7 DENSITY ALTITUDE: 2000

UTC	VIS1	D/N1	VIS2	D/N2	VIS3	D/N3	WIND	DIR/SPD	5SEC	WIND	RVR
1925	0.210	D			0.205	D	294	5	311	6	36L50
1926	0.211	D			0.194	D	304	5	319	5	36L57
1927	0.222	D			0.191	D	313	5	328	7	36L10
1928	0.220	D			0.191	D	301	6	264	6	36L02
1929	0.222	D			0.198	D	283	5	282	6	36L03
1930	0.227	D			0.204	D	269	5	243	5	36L04
1931	0.229	D			0.206	D	243	4	258	4	36L10
1932	0.231	D			0.198	D	213	3	188	4	36L10
1933	0.236	D			0.201	D	177	3	162	3	36L14
1934	0.232	D			0.210	D	159	3	182	4	36L16
1935	0.234	D			0.212	D	197	3	248	3	36L18
1936	0.237	D			0.216	D	233	4	236	6	36L22

12HR ARCHIVE

SPECIAL GENERATED AT 10TH READING

RVR/ASOS INTERFACE TEST TROUBLE REPORT		TTR-021
DATE: 6/26/97	TIME: 3:00PM	SITE: MEM
SYSTEMS/COMPONENTS IN ISSUE:		
RVR DPU <input checked="" type="checkbox"/>	RVR MDT <input checked="" type="checkbox"/>	ASOS ACU <input type="checkbox"/>
RVR SIE <input type="checkbox"/>	INTERIM INTERFACE <input type="checkbox"/>	ASOS DISPLAY <input type="checkbox"/>
RVR CD <input checked="" type="checkbox"/>	FINAL INTERFRACE <input type="checkbox"/>	MPS <input type="checkbox"/>
TEST EQUIPMENT USED:		
PROTOCOL ANALYZER <input type="checkbox"/>		
OTHER:		
TEST PLAN ID:		
TEST PROCEDURE ID: STEP(S):		
DESCRIPTION OF ISSUE/PROBLEM:		
When deconfiguring a runway from the MDT (36L), the CD alarm continually beeped until the ALM ACK button was pushed. (We expected 3 beeps). 36L was flashing on CD which was expected this problem was noticed with the ASOS card not configured and not installed.		
NEW GENERATION RVR SOFTWARE VERSION ID: 5.0		
ASOS SOFTWARE VERSION ID: N/A		
Mike McKinney	6/26/97	
ISSUE/PROBLEM WITNESS	DATE	
Michael Jones	6/26/97	
FAA TEST DIRECTOR/REPRESENTATIVE	DATE	
Mike McKinney	6/26/97	
NWS REPRESENTATIVE	DATE	
NOAA REPRESENTATIVE	DATE	

