

te technical note tech

Runway Visual Range (RVR) Automated Surface Observing System (ASOS) Functional Test Report

William Benner
Michael McKinney

9981127 081

September 1998
DOT/FAA/CT-TN98/19

Document is on file at the William J. Hughes Technical Center
Library, Atlantic City International Airport, NJ 08405

U.S. Department of Transportation
Federal Aviation Administration
William J. Hughes Technical Center
Atlantic City International Airport, NJ 08405

NOTICE

This document is disseminated under the sponsorship of the U.S. Department of Transportation in the interest of information exchange. The United States Government assumes no liability for the contents or use thereof.

The United States Government does not endorse products or manufacturers. Trade or manufacturers' names appear herein solely because they are considered essential to the objective of this report.

Technical Report Documentation Page

1. Report No. DOT/FAA/CT-TN98/19		2. Government Accession No.		3. Recipient's Catalog No.	
4. Title and Subtitle Runway Visual Range (RVR) Automated Surface Observing System (ASOS) Functional Test Report				5. Report Date September 1998	
				6. Performing Organization Code ACT-320	
7. Author(s) William Benner, Michael McKinney; Michael Jones, Raytheon Service Co.				8. Performing Organization Report No. DOT/FAA/CT-TN98/19	
9. Performing Organization Name and Address U.S. Department of Transportation Federal Aviation Administration William J. Hughes Technical Center Atlantic City International Airport, N.J. 08405				10. Work Unit No. (TRAIS)	
				11. Contract or Grant No.	
12. Sponsoring Agency Name and Address U.S. Department of Transportation Federal Aviation Administration William J. Hughes Technical Center Atlantic City International Airport, N.J. 08405				13. Type of Report and Period Covered Technical Note	
				14. Sponsoring Agency Code	
15. Supplementary Notes This effort was performed in cooperation with the Federal Aviation Administration William J. Hughes Technical Center and project personnel from Raytheon Service Co. in Pleasantville, New Jersey.					
16. Abstract Runway Visual Range (RVR) Automated Surface Observing System (ASOS) functions were evaluated during tests conducted at Memphis International Airport (MEM) from April 14 through 16, 1998. Representatives from the Federal Aviation Administration (FAA) William J. Hughes Technical Center Weather Communication Branch performed the testing. Testing was initiated in response to ASOS software modifications which contained corrections to problems existing on earlier versions. The primary intent of testing was to verify that RVR ASOS functions operated in accordance with requirements and to determine if problems could be expected during operation with the Interim and Final Phase New Generation RVR/ASOS Interface. Five performance issues were encountered during testing. Four issues concerned ASOS performance and one related to operation of the HP Palmtop PC, i.e., Interim RVR/ASOS Interface. Since all of these issues currently have "work-arounds" or established methods to avoid/correct the problem, they are not expected to adversely affect Long-Line RVR service. As a result, ACT-320 recommends use of ASOS software version 2.53 at sites designated for Long-Line RVR reporting with the Interim or Final Phase RVR/ASOS Interface.					
17. Key Words METAR, NORVR, Weather Special, Application Data Unit			18. Distribution Statement Document is on file at the Technical Center Library, Atlantic City International Airport, NJ 08405		
19. Security Classif. (of this report) Unclassified		20. Security Classif. (of this page) Unclassified		21. No. of Pages 33	22. Price

TABLE OF CONTENTS

	Page
EXECUTIVE SUMMARY	v
1. BACKGROUND	1
1.1 Purpose	2
1.2 Scope	2
2. REFERENCE DOCUMENTS	2
3. SYSTEM DESCRIPTION	2
3.1 New Generation RVR Mission Review	2
3.2 ASOS Mission Review	3
3.3 Test System Configuration	4
3.4 Interfaces	5
4. TEST DESCRIPTION	5
4.1 Test Schedule and Location	6
4.2 Participants	6
4.3 Test Objectives and Criteria	6
4.4 Test Setup and Conduct	6
4.5 Data Collection and Analysis Methods	16
5. TEST RESULTS	17
5.1 ISSUE: FALSE NONOPERATIONAL RVR MESSAGE	18
5.2 ISSUE: COMMUNICATION PROTOCOL NOT IN ACCORDANCE WITH ICD	19
5.3 ISSUE: COMMUNICATION PROTOCOL MISMATCH NOT DETECTED	19
5.4 ISSUE: RVR FUNCTION REMAINS NONOPERATIONAL on ASOS	20
5.5 ISSUE: RVR/ASOS COMMUNICATION FAILURE	20
6. CONCLUSION	21
7. RECOMMENDATIONS	21
8. ACRONYMS	22
APPENDIX	

LIST OF ILLUSTRATIONS

Figure		Page
3.4-1	RVR/ASOS Application Data Unit	5
4.4.1.2-1	Simulated RVR to ASOS Test Setup	7
4.4.2.1.1-1	Operational Procedure Test Setup	13
4.4.3.2-1	Data Communication Failure Test Setup	16

LIST OF TABLES

Table		Page
1	New Generation RVR Configuration	4
2	ASOS Configuration	4
3	Interim RVR/ASOS Interface Configuration	5
4	SCRIPT FILE RVRMSG3.DAT	9
5	SCRIPT FILE RVRMSG4.DAT	9
6	SCRIPT FILE RVRMSG5.DAT	10
7	SCRIPT FILE RVRMSG6.DAT	11
8	SCRIPT FILE RVRMSG7.DAT	11
9	ADU Communication Script	14
10	DCFS and ASOS Communication Protocols Tested	15
11	HP Palmtop and ASOS Communication Protocols Tested	15
12	DCFS-ASOS Communication Protocol Results	17
13	HP PALMTOP-ASOS Communication Protocol Results	18

EXECUTIVE SUMMARY

Runway Visual Range (RVR) Automated Surface Observing System (ASOS) functions were evaluated during tests conducted at Memphis International Airport (MEM) from April 14 to 16, 1998. Representatives from the Federal Aviation Administration (FAA) William J. Hughes Technical Center performed the testing with cooperation from the National Weather Service (NWS).

Testing was performed in response to ASOS software modifications and the release of Acquisition Control Unit (ACU) software version 2.53, which contained corrections to problems existing on earlier versions. The primary intent of testing was to verify if ASOS RVR functions operated in accordance with requirements and to determine if problems could be expected during operation with the Interim and Final Phase New Generation RVR Interface. To satisfy these concerns, testing focused on verifying ASOS capabilities in providing Long-Line RVR, i.e., 10-minute average RVR reading calculated at light setting 5, during operating conditions such as:

- a. Transfer and Display of Long-Line RVR data,
- b. RVR/ASOS Communication Problems, and
- c. ASOS Maintenance.

Subsets of procedures performed during previous Operational Test and Evaluation (OT&E) sessions with the Interim and Final RVR/ASOS Interface were executed to complete testing. New procedures were also executed to determine system performance in response to RVR/ASOS communication issues.

The ASOS demonstrated an ability to receive and display Long-Line RVR data on all applicable display screens. In response to communication problems, the ASOS generally provided a response suitable for field usage. ASOS maintenance functions such as fault diagnosis and system configuration had no adverse effect on Long-Line RVR service.

Five performance issues were encountered during testing. Four issues concerned ASOS performance and one related to operation of the HP Palmtop PC, i.e., Interim RVR/ASOS Interface. Since all of these issues currently have "work-arounds" or established methods to avoid/correct the problem, they are not expected to adversely affect Long-Line RVR service.

As a result, ACT-320 recommends use of ASOS software 2.53 at sites designated for Long-Line RVR reporting with the Interim or Final Phase RVR/ASOS Interface.

1. BACKGROUND.

Collaborative efforts from the Federal Aviation Administration (FAA) and National Weather Service (NWS) have resulted in the implementation of Long-Line Runway Visual Range (RVR) service¹ at locations throughout the U.S. As of April 1998, 10 operational sites exist at the following cities: Los Angeles, CA; Nashville, TN; Seattle, WA; Portland, OR; Chicago, IL; Kansas City, MO; Detroit, MI; Milwaukee, WI; Dayton, OH, and Charleston, WV. FAA plans include additional installation efforts throughout the U.S. throughout 1998 and 1999. Future plans for Long-Line RVR service include operation at approximately 110 U.S. airports.

Airport readiness for Long-Line RVR service include a commissioned New Generation RVR system configured with National Deployment Baseline (NDB+1) Version 1 software and an accepted or commissioned Automated Surface Observing System (ASOS) with Acquisition Control Unit (ACU) software version 2.45, or later. More recent software versions installed on the New Generation RVR and ASOS are also designed for Long-Line RVR reporting.

In addition to the software configuration requirements for each system, airports must receive an installation of the Interim or Final Phase RVR/ASOS Interface. Although both interfaces are functionally the same, they consist of different components and are not being deployed simultaneously.

The Interim RVR/ASOS Interface is currently available for deployment and consists of the following components:

- a. Hewlett Packard 200 LX Palmtop personal computer (HP Palmtop PC),
- b. RVR/ASOS executable software,
- c. RS232-EIA-530 Signal Level Converter,
- d. Alternating Current (AC) adapters, and
- e. Serial data cables.

The serial data cables provide connections to the New Generation RVR, ASOS, and the participating Interim RVR/ASOS Interface components. Depending on the distance between the New Generation RVR Data Processing Unit (DPU) and the ASOS ACU, modems or signal transmission devices may also be required.

The Final RVR/ASOS Interface has undergone formal Operational Test and Evaluation (OT&E) conducted during June 1997. The interface passed OT&E tests and will be deployed after FAA

¹Long-Line RVR service is obtained from the ASOS and is consists of the 10-minute average RVR reading calculated with light setting 5 from a designated Touchdown RVR Visibility Sensor (VS).

production and dissemination cycles are complete. The Final RVR/ASOS Interface consists of an Intelligent Communication Controller Card (ICCC), which resides within the New Generation RVR DPU and software version 5.0 for the DPU Maintenance Processor (MPU) and Product Processing Units (PPU). The Final RVR/ASOS Interface also contains an EIA-530 Interface port for the transmission of Long-Line RVR data without signal conversion to ASOS. The Final RVR/ASOS Interface is compatible with the same ASOS software versions as used with the Interim RVR/ASOS Interface.

1.1 PURPOSE.

The purpose of this report is to discuss results of an RVR functional test performed on the ASOS from April 14 through 16, 1998, at Memphis International Airport (MEM).

1.2 SCOPE.

This report discusses results of testing ASOS RVR functions. The report includes descriptions of test scenarios and test system configuration. Operational problems encountered during testing are described as well as ACT-320 recommendations for problem resolution.

2. REFERENCE DOCUMENTS.

This document was developed in accordance with Acquisition Management System Test and Evaluation Guidelines, dated July 18, 1997.

3. SYSTEM DESCRIPTION.

This section provides a mission review summary for the New Generation RVR and ASOS and a brief description of the test system configuration for the New Generation RVR, ASOS, and Interim RVR/ASOS Interface.

3.1 NEW GENERATION RVR MISSION REVIEW.

The New Generation RVR system is designed to provide measurement of runway visibility at specific points along a precision runway. The system supports instrument landings during Category I, II, IIIa/b visibility conditions as defined in specification FAA-E-2772. To provide RVR data, the system determines the following parameters:

- a. Ambient light intensity,
- b. Atmospheric scattering coefficient, and
- c. Runway centerline/edge light intensity.

The system processes this data to output distances a pilot could expect to see along the departure or approach path of the runway. The New Generation RVR system is designed to decrease the maintenance load and installation difficulties associated with predecessor runway visual range systems. Future expansion capabilities will be easier and less costly.

3.2 ASOS MISSION REVIEW.

The ASOS utilizes sensors located on the airfield to measure weather parameters such as wind speed/direction, ambient temperature, and precipitation. Deployment of ASOS has permitted the automatic dissemination of Aviation Routine Weather Report (METAR) messages to various users including: the airlines, pilots, and Flight Service Stations (FSS). The METAR message allows RVR data to be contained within the main portion of the report. This feature is a modification from the predecessor to the METAR report, the Surface Aviation Observation (SAO), which only allowed RVR data within the "REMARKS" section.

As a result of implementation of the New Generation RVR/ASOS Interface and software upgrades on the ASOS, manual input of RVR data on the ASOS is no longer required. RVR data can now be automatically transferred from the New Generation RVR to the ASOS through the Final or Interim Phase RVR/ASOS Interface. Since July 1, 1996, RVR products disseminated through ASOS have been reported as part of the METAR message, and the SAO format message has been discontinued.

The ASOS system senses and measures the following:

- a. Wind speed/direction;
- b. Ambient temperature;
- c. Dewpoint temperature;
- d. Atmospheric pressure;
- e. Visibility;
- f. Cloud layer height--reported as Sky Condition;
- g. Precipitation Type and Intensity--reported as Present Weather;
- h. Liquid Precipitation Accumulation; and
- i. Freezing rain occurrence.

ASOS collects RVR information through an interface port residing in its ACU. Additionally, ASOS can transmit weather observations (i.e., SAO's or METAR format) once a minute to the Automated Weather Observing System (AWOS) Data Acquisition System (ADAS) in response to polls from ADAS. The weather observation is then distributed for use by the FAA, NWS, airlines, and pilots.

3.3 TEST SYSTEM CONFIGURATION.

Tables 1 through 3 describe the MEM New Generation RVR, ASOS, and Interim RVR/ASOS Interface configurations used during testing.

TABLE 1. NEW GENERATION RVR CONFIGURATION

COMPONENT	NO.	ADDITIONAL INFORMATION
Visibility Sensor	6	Located For 36L, 36C, 36R
Ambient Light Sensor	1	Located on Administration Building Roof
Runway Light Intensity Monitor	2	Located in Electrical Power Vault
Data Processing Unit	1	Configured with RVR/ASOS Interface;
Controller Display	11	Located in Tower Cab, TRACON, and Equipment Room
Software Components -Maintenance Processor Unit -Product Processing Unit A -Product Processing Unit B -VS SIE -ALS SIE -RLIM SIE -RVR/ASOS Interface -Controller Display	8	SOFTWARE VERSION ID 1101966050 1101966050 1101966050 1523952041 1523953043 0430944040 1017967010 4.3

TABLE 2. ASOS CONFIGURATION

COMPONENT	NO.	ADDITIONAL INFORMATION
Acquisition Control Unit	1	Software Version 2.53
Pressure Sensors	3	
Operator Interface Device	2	Located In ATCT
Video Display Unit	1	Located In Contract Weather Office
Printer	1	Located In ATCT
Data Collection Package #1 -Present Weather Sensor (LEDWI) -Temperature Dewpoint Sensor -Wind Speed & Direction Sensor Liquid Precipitation Sensor	1	Centerfield Airport Location
Data Collection Package #2 -Visibility Sensor [Primary] -Ceilometer (CHI) [Primary]	1	Runway Touchdown Zone
Data Collection Package #3 -Visibility Sensor [Backup] -Ceilometer (CHI) [Backup]	1	Runway Touchdown Zone

TABLE 3. INTERIM RVR/ASOS INTERFACE CONFIGURATION

COMPONENT	ADDITIONAL INFORMATION
HP Palmtop PC	RVR/ASOS software version 1.1, DOS 5.0, 5MB Flash RAM, AC adapter
Telebyte RS232-EIA530 Level Converter	DCE Input, DTE Output, AC adapter
Serial Data Cables	1-Split Cable for connection to New Generation RVR DPU and HP Palmtop PC; 1-Four conduct cable for connection to Lever Converter output and ASOS RVR input

3.4 INTERFACES.

The Final and Interim RVR/ASOS Interface and a PC-based ASOS Application Data Unit (ADU) generator were used in separate test scenarios to transfer data to the ASOS during testing. Each of these interfaces was equipped to create an ADU of the format shown in figure 3.4-1. To simulate normal communication scenarios involving the PC-based ASOS ADU generator, the ADU was transferred to the ASOS ACU at a rate of twice per minute.

Time Stamp	Runway ID	Runway Sub ID	RVR Product
------------	-----------	---------------	-------------

FIGURE 3.4-1. RVR/ASOS APPLICATION DATA UNIT

The DPU Maintenance Data Terminal (MDT) interface was used to control New Generation RVR parameters and functions. A local ASOS ACU interface permitted use of an Operator Information Display (OID) to monitor all RVR-related display screens on ASOS. The OID also permitted direct control of the ASOS throughout testing.

4. TEST DESCRIPTION.

This section briefly discusses the following topics: test schedule and location, participants, test objectives and criteria, test setup and conduct, and data collection and analysis.

4.1 TEST SCHEDULE AND LOCATION.

The ASOS RVR Function Test was scheduled to be conducted at MEM during the week of April 12, 1998. Since only ASOS RVR functions were being evaluated, the test session was anticipated to last approximately 2 days.

4.2 PARTICIPANTS.

Personnel from the FAA William J. Hughes Technical Center (Technical Center) conducted and performed the testing. Technical Center (ACT-320) personnel functioned as Test Director and Test Engineers during the test. These representatives performed the installation of Interim RVR/ASOS Interface components and test equipment required for testing. Technical Center representatives also executed tests and conducted on-site evaluation and analysis required on the ASOS. NWS representatives provided remote technical assistance for specific ASOS operational issues as requested by ACT-320 personnel.

MEM personnel provided access to New Generation RVR and ASOS equipment facilities. MEM personnel also secured and provided additional printers, monitors, tables, etc., needed for testing.

4.3 TEST OBJECTIVES AND CRITERIA.

The primary objective of the ASOS RVR Function Test was to determine if ASOS RVR-related functions and capabilities performed in accordance with design specifications and the RVR/ASOS Interface Control Document--50-SANW-1-00050. The test was also intended to verify proper display of RVR data on the ASOS.

4.4 TEST SETUP AND CONDUCT.

Three test categories were performed on the ASOS. Each test category and the corresponding setup and conduct is provided in the following subparagraphs. The categories are identified as follows:

- a. Simulated RVR to ASOS Test,
- b. Operational Procedure Test, and
- c. Data Communication Failure Test.

4.4.1 Simulated RVR to ASOS Test.

The Simulated RVR to ASOS Test was the first test performed. This test featured use of a PC-based ASOS ADU generator which replicated Interim RVR/ASOS Interface output functionality by sending ASOS ADUs to the ASOS ACU. The ADU generator was programmed to transmit a range of RVR products, e.g., 100 feet to

6500 feet, usually with a different product transmitted each minute, and function continuously without operator intervention.

ASOS ADU generator RVR products were transmitted at the same rate i.e., 2x/minute, as from the Interim RVR/ASOS Interface. Non-numeric and illegal RVR products such as "FFF", " ", and "(+" were also transmitted from the ADU generator. The applicable ASOS display screens were retrieved to display RVR products as they were received. The test focused on verifying whether RVR products displayed on the ASOS display matched transmitted ADU products. The ADU generator transmitted RVR products for approximately 3 hours under control of several script files. Paragraph 4.4.1.2.1 discusses the intent of each script file used during testing.

4.4.1.1 Simulated RVR to ASOS Test Objectives.

The objective of the Simulated RVR to ASOS Test was to verify proper operation of ASOS RVR functions such as generation of "RVR Specials," RVR Nonoperation and Operation indications, and missing RVR data indications.

4.4.1.2 Simulated RVR to ASOS Test Setup.

The ASOS ADU generator was connected to ASOS as shown in figure 4.4.1.2-1. ASOS was initialized with its operational software during test setup.

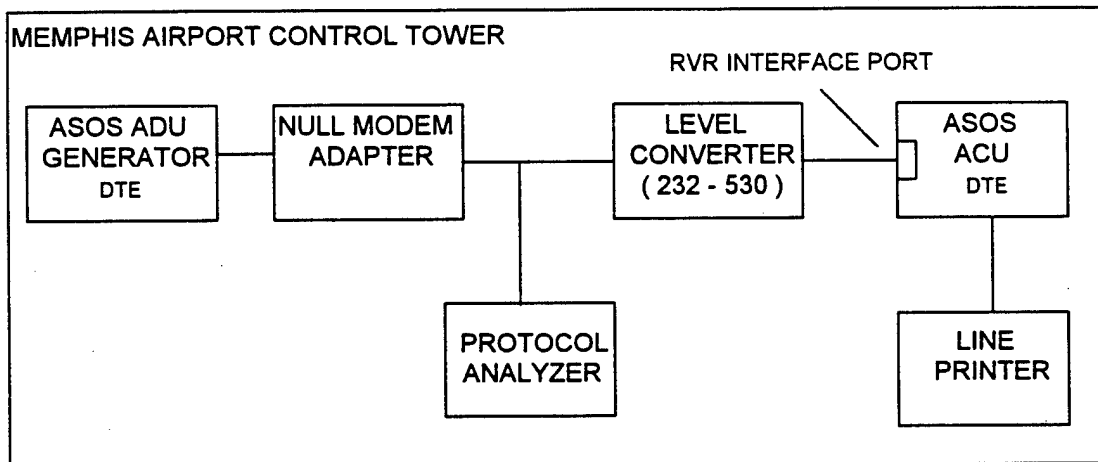

FIGURE 4.4.1.2-1. SIMULATED RVR TO ASOS TEST SETUP

4.4.1.2.1 ADU Generator Script Files.

Script files identified in paragraphs 4.4.1.2.1.1 through 4.4.1.2.1.5 were used to output preprogrammed RVR products during the Simulated RVR to ASOS Test. File contents are listed in tables 4 to 8. A brief discussion of the script file precedes each table.

For each table, the row labeled with RWYID represents the runway identifier included in each RVR product transmitted. The PROD# column identifies the order of the product transmitted. The column labeled VALUE contains the actual RVR product transmitted. The ADU generator was configured to repeat the script file output sequence immediately after transmission of the last product in the file. For example, in table 3, PROD# 1 was transmitted after PROD# 60.

4.4.1.2.1.1 RVRMSG3.DAT.

RVRMSG3.DAT was designed specifically to verify whether ASOS "specials," or detection of significant weather parameter changes, were properly generated in response to RVR product variations.

Since ASOS processing software was designed to generate an RVR special when the RVR product crossed 2400 feet (in both directions), typical RVR product values on each side of the 2400-foot threshold were included in RVRMSG3.DAT to test this function. An additional requirement for the ASOS special was that the RVR product must remain above/below the threshold for at least 10 minutes. This was accounted for in the RVRMSG3.DAT file by including 10 minutes or at least 20 RVR product readings above and below 2400 feet. FFF products were included at the end of the script file sequence to verify whether the occurrence of a series of non-numeric products would prevent proper detection and notification of RVR weather specials. To determine if an RVR special was generated when RVR readings increased past the 2400-foot threshold, the RVRMSG3.DAT file contained an RVR product sequence where a series of 2200-foot RVR readings (represented by the number 22) changed to a series of 2600-foot readings (represented by the number 26).

TABLE 4. SCRIPT FILE RVRMSG3.DAT

RWYID	02L								
PROD#	VALUE	PROD#	VALUE	PROD#	VALUE	PROD#	VALUE	PROD#	VALUE
1	22	13	22	25	26	37	26	49	FFF
2	22	14	22	26	26	38	26	50	FFF
3	22	15	22	27	26	39	26	51	FFF
4	22	16	22	28	26	40	26	52	FFF
5	22	17	22	29	26	41	FFF	53	FFF
6	22	18	22	30	26	42	FFF	54	FFF
7	22	19	22	31	26	43	FFF	55	FFF
8	22	20	22	32	26	44	FFF	56	FFF
9	22	21	26	33	26	45	FFF	57	FFF
10	22	22	26	34	26	46	FFF	58	FFF
11	22	23	26	35	26	47	FFF	59	FFF
12	22	24	26	36	26	48	FFF	60	FFF

4.4.1.2.1.2 RVRMSG4.DAT.

RVRMSG4.DAT was designed with the same general intent as RVRMSG3.DAT, but was specifically intended to verify generation of an ASOS RVR special in response to a decrease in RVR readings through the 2400-foot threshold. As a result, the RVR product sequence contained the transition from a series of 2600-foot products to a series of 2200-foot products.

TABLE 5. SCRIPT FILE RVRMSG4.DAT

RWYID	02L								
PROD#	VALUE	PROD#	VALUE	PROD#	VALUE	PROD#	VALUE	PROD#	VALUE
1	26	13	26	25	22	37	22	49	FFF
2	26	14	26	26	22	38	22	50	FFF
3	26	15	26	27	22	39	22	51	FFF
4	26	16	26	28	22	40	22	52	FFF
5	26	17	26	29	22	41	FFF	53	FFF
6	26	18	26	30	22	42	FFF	54	FFF
7	26	19	26	31	22	43	FFF	55	FFF
8	26	20	26	32	22	44	FFF	56	FFF
9	26	21	22	33	22	45	FFF	57	FFF
10	26	22	22	34	22	46	FFF	58	FFF
11	26	23	22	35	22	47	FFF	59	FFF
12	26	24	22	36	22	48	FFF	60	FFF

4.4.1.2.1.3 RVRMSG5.DAT.

RVRMSG5.DAT was intended to verify proper ASOS reception and display of non-numeric RVR products such as " ", FFF, and 60+. Additionally, the file was configured to verify generation of an RVR special by including a transition from products below and above 2400 feet. This file was also intended to verify proper reception and display of a runway identifier, "36", without letter designation, i.e., L, R, or C.

TABLE 6. SCRIPT FILE RVRMSG5.DAT

RWYID	36						
PROD#	VALUE	PROD#	VALUE	PROD#	VALUE	PROD#	VALUE
1	10	13	16	25	FFF	37	60+
2	02	14	18	26	60+	38	60+
3	03	15	18	27	60+	39	60+
4	03	16	22	28	60+	40	
5	04	17	22	29	60+	41	
6	04	18	22	30	60+	42	
7	10	19		31	60+	43	02
8	10	20		32	60+	44	50
9	10	21		33	60+	45	50
10	14	22		34	60+	46	55
11	14	23	FFF	35	60+	47	57
12	16	23	FFF	35	60+	47	57

4.4.1.2.1.4 RVRMSG6.DAT.

The RVRMSG6.DAT file was designed to verify whether the entire range of RVR products would be properly displayed on ASOS and verify proper generation of RVR-related specials. For this file, a series of RVR products different from the previous files were used. For RVR products below the 2400-foot threshold, RVRMSG6.DAT was configured to allow a different RVR product to be transmitted each minute. For products above 2400 feet, the same product was transmitted each minute until the final 2 minutes.

TABLE 7. SCRIPT FILE RVRMSG6.DAT

RWYID	36L								
PROD#	VALUE	PROD#	VALUE	PROD#	VALUE	PROD#	VALUE	PROD#	VALUE
1	01	11	10	21	60+	31	60+	41	57
2	01	12	10	22	60+	32	60+	42	57
3	02	13	14	23	60+	33	60+		
4	02	14	14	24	60+	34	60+		
5	03	15	16	25	60+	35	60+		
6	03	16	16	26	60+	36	60+		
7	04	17	18	27	60+	37	60+		
8	04	18	18	28	60+	38	60+		
9	10	19	22	29	60+	39	50		
10	10	20	22	30	60+	40	50		

4.4.1.2.1.5 RVRMSG7.DAT.

The RVRMSG7.DAT file was designed to verify how properly formatted, and non-numeric RVR products would be accounted for on ASOS display screens. To accomplish this, RVRMSG7.DAT contained a series of legal and typical RVR products followed by instances of non-numeric products not in accordance with the RVR/ASOS Interface Control Document (ICD).

TABLE 8. SCRIPT FILE RVRMSG7.DAT

RWYID	36L								
PROD#	VALUE	PROD#	VALUE	PROD#	VALUE	PROD#	VALUE	PROD#	VALUE
1	01	7	04	13	07	19	(+	41	60+
2	01	8	04	14	07	20	(+	42	60+
3	02	9	05	15	08	21	(+		
4	02	10	05	16	08	22	(+		
5	03	11	06	17	(+	23	60+		
6	03	12	06	18	(+	24	60+		

4.4.2 Operational Procedure Test.

The Operational Procedure Test consisted of performing a subset of system tasks on the New Generation RVR and ASOS such as restarts, maintenance, configuration, and fault diagnosis. While these system tasks were performed, ASOS RVR functions were monitored for performance degradation and anomalies. The following categories of tasks were performed:

- a. Component restart. For the New Generation RVR system, the PPU, MPU, VS, ALS, and ASOS Interface components were reset. The ASOS ACU was also reset.
- b. Maintenance. ASOS maintenance as described in the Site Technical and Software Users manual was performed.
- c. Configuration. The ASOS RVR communication port was set with various communication protocols to enable or disable RVR data display. ASOS RVR report processing parameters were also manipulated to verify operational performance.
- d. Fault diagnosis. Fault diagnostic tests were performed on the ASOS for RVR-related parameters.

4.4.2.1 Operational Procedure Test Objectives.

The objective of the Operational Procedure Test was to verify proper operation of ASOS RVR functions during RVR and ASOS operational functions.

4.4.2.1.1 Operational Procedure Test Setup.

Data collection devices, test equipment, and the RVR/ASOS interface were connected as shown in figure 4.4.2.1.1-1.

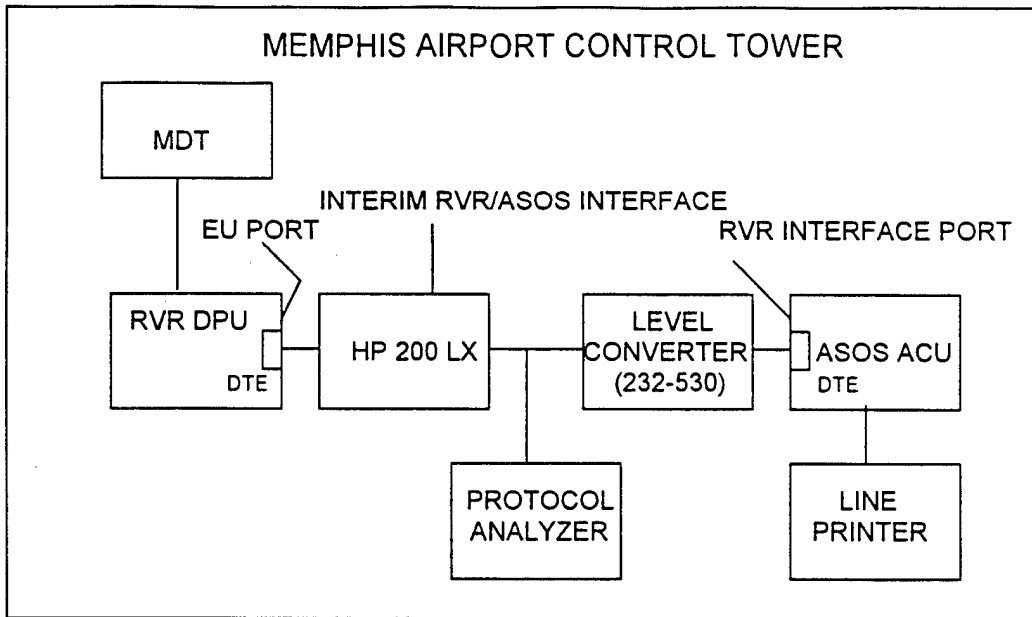

FIGURE 4.4.2.1.1-1. OPERATIONAL PROCEDURE TEST SETUP²

4.4.3 Data Communication Failure Test.

The Data Communication Failure Test featured a simulation of various RVR to ASOS communication problems that could occur under operational conditions with the Interim or Final RVR/ASOS Interface and ASOS. Simulated communication problems included protocol mismatch, erroneous block check codes, parity errors, baud rate conflicts, and cable disconnect. ASOS performance was monitored during the existence and recovery phases of the problem.

Most communication problems were simulated via the use of a PC-based Data Communication Fault Simulator (DCFS). The DCFS allowed the operator to enter any desired ADU and the associated communication protocol parameters such as Start of Text (STX), End of Text (ETX), and Block Check Code (BCC). The ADUs were preprogrammed within script files and generated in real-time in between ADU transmission intervals. Real-time control of parity settings (none, even, odd), the number of stop bits (0,1,2,..) and the baud rate (2400...19200) were also controlled via the DCFS. For each ADU transmitted, these parameters were set for testing purposes.

²The Operational Procedure Test was also performed with the Final RVR/ASOS Interface. The setup was identical to that indicated in figure 4.4.2.1.1-1 but did not include the HP Palmtop and Level Converter.

Table 9 indicates the ADU communication script used during the test. The serial port protocol settings of 2400 baud, Even Parity, and 1 Stop bit were used during all communication script transmissions. The column labeled ADU indicates the order each ADU was sent. The column labeled TRANSMITTED ADU contains the actual ADU transmitted and the column entitled COMMUNICATION FAULT describes the fault contained within the ADU. Each ADU was transmitted at the rate defined by the RVR/ASOS ICD of 2x per minute (approximately every 30 seconds). The DCFS was configured to automatically replay the initiated script after the last item in the file was transmitted. For instance, ADU #1 followed ADU #20.

TABLE 9. ADU COMMUNICATION SCRIPT

ADU#	TRANSMITTED ADU	COMMUNICATION FAULT
1	<SOH>134756<STX>27L55<ETX><BCC>	None
2	<SOH>134756<STX>27L55<ETX><BCC>	None
3	<SOH>134756<STX>27L55<ETX><BCC>	None
4	<SOH>134756<STX>27L55<ETX><BCC>	None
5	134756<STX>27L55<ETX><BCC>	Missing <SOH>
6	134756<STX>27L55<ETX><BCC>	Missing <SOH>
7	134756<STX>27L55<ETX><BCC>	Missing <SOH>
8	134756<STX>27L55<ETX><BCC>	Missing <SOH>
9	<SOH>13475627L55<ETX><BCC>	Missing <STX>
10	<SOH>13475627L55<ETX><BCC>	Missing <STX>
11	<SOH>13475627L55<ETX><BCC>	Missing <STX>
12	<SOH>13475627L55<ETX><BCC>	Missing <STX>
13	<SOH>13475627L55<ETX><BCC>	Missing <STX>
14	<SOH>134756<STX>27L55<BCC>	Missing <ETX>
15	<SOH>134756<STX>27L55<BCC>	Missing <ETX>
16	<SOH>134756<STX>27L55<BCC>	Missing <ETX>
17	<SOH>134756<STX>27L55<BCC>	Missing <ETX>
18	<SOH>134756<STX>27L55<ETX><BCC>	Bad BCC
19	<SOH>134756<STX>27L55<ETX><BCC>	Bad BCC
20	<SOH>134756<STX>27L55<ETX><BCC>	Bad BCC

Tables 10 and 11 indicate the serial port settings used during tests where a communication protocol mismatch was created by manually configuring the DCFS and ASOS serial ports. After the mismatch was established, the ASOS was examined to determine if RVR data was received and if a diagnostic message was given when data was not displayed. The column labeled DCFS indicates the DCFS serial port configuration and the column labeled ASOS indicates the configuration of the ASOS RVR serial port. The PROTOCOL column maps the protocol combination used with a number.

TABLE 10. DCFS and ASOS COMMUNICATION PROTOCOLS TESTED

PROTOCOL	DCFS	ASOS
1	2400,E,7,1	2400,E,7,1
2	2400,O,7,1	2400,E,7,1
3	2400,N,7,1	2400,E,7,1
4	2400,E,8,1	2400,E,7,1
5	2400,O,8,1	2400,E,7,1
6	2400,N,8,1	2400,E,7,1
7	2400,E,6,1	2400,E,7,1
8	2400,O,6,1	2400,E,7,1
9	2400,N,6,1	2400,E,7,1
10	2400,O,7,1	2400,O,7,1
11	2400,N,8,1	2400,N,8,1
12	2400,N,7,1	2400,N,8,1
13	2400,N,7,1	2400,N,7,1

TABLE 11. HP PALMTOP and ASOS COMMUNICATION PROTOCOLS TESTED

PROTOCOL	HP PALMTOP CONFIGURATION	ASOS CONFIGURATION
1	2400,N,8,1	2400,N,8,1
2	2400,N,8,1	2400,E,7,1

4.4.3.1 Data Communication Failure Test Objectives.

The objective of the Data Communication Failure Test was to determine whether the ASOS could properly recover and handle communication problems that could occur during operation. This included detection and notification of communication problems as well as recovery. For example, if the ASOS detects it has not received RVR data for 3 minutes or more, an RVR Nonoperational message is normally displayed and the event is automatically recorded within ASOS communication and system logs. In this example, the detection and continued reception of RVR data for at least 7 minutes would be required to remove the RVR Nonoperational message and generate the proper recovery messages within the system and communication logs. Performance features of this type were verified during the test.

4.4.3.2 Data Communication Failure Test Setup.

A PC-based DCFS was connected to ASOS as shown in figure 4.4.3.2-1.

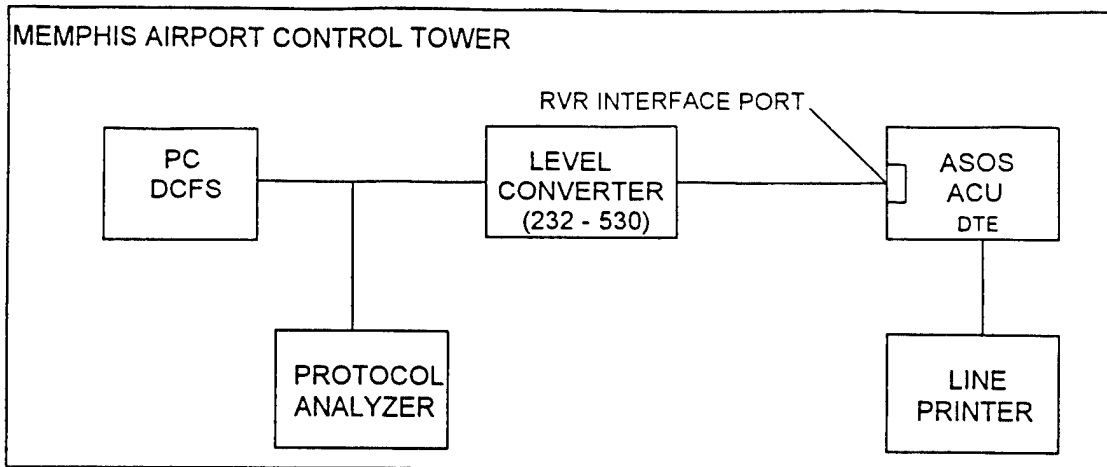

FIGURE 4.4.3.2-1. DATA COMMUNICATION FAILURE TEST SETUP

4.5 DATA COLLECTION AND ANALYSIS METHODS.

For each test conducted data collection was accomplished through use of the following equipment and resources:

- a. Protocol analyzer;
- b. Test team observations--test conduct forms were used to record data from ASOS display screens and the RVR controller display; and
- c. ASOS printer--for capturing METAR reports and related display screens.
- d. DPU MDT--to control New Generation RVR operation during testing.

Data analysis consisted of comparing protocol analyzer data with Long-Line RVR data displayed on the ASOS. Analysis also consisted of verifying the proper updates to ASOS system and communication logs in response to RVR data status changes. ASOS functional analysis was also performed by verifying the proper execution of ASOS RVR-related functions.

5. TEST RESULTS.

Results indicate ASOS RVR functions performed in accordance with design specifications and the RVR/ASOS ICD. RVR weather specials were confirmed to occur in response to the proper transition of RVR products. ASOS RVR Operational and Nonoperational messages were also confirmed to occur when RVR data was detected and in accordance with design algorithms.

For RVR/ASOS communication problems, it appears the BCC is the only parameter used by ASOS software for error detection. As a result, the state of protocol parameters such as the Parity and Stop bit have no impact in determining whether a communication error exists. Table 12 summarizes results of the Data Communication Failure Test whereby various communication protocols were configured on the ASOS and the DCFS. The format of table 12 is the same as table 10 with the addition of the outcome for each test contained in the last two columns.

TABLE 12. DCFS-ASOS COMMUNICATION PROTOCOL RESULTS

PROTOCOL	DCFS	ASOS	RVR DATA DETECTED	DIAGNOSTIC
1	2400,E,7,1	2400,E,7,1	YES	-
2	2400,O,7,1	2400,E,7,1	YES	-
3	2400,N,7,1	2400,E,7,1	YES	-
4	2400,E,8,1	2400,E,7,1	YES	-
5	2400,O,8,1	2400,E,7,1	YES	-
6	2400,N,8,1	2400,E,7,1	YES	-
7	2400,E,6,1	2400,E,7,1	NO	YES
8	2400,O,6,1	2400,E,7,1	NO	YES
9	2400,N,6,1	2400,E,7,1	NO	YES
10	2400,O,7,1	2400,O,7,1	YES	-
11	2400,N,8,1	2400,N,8,1	YES	-
12	2400,N,7,1	2400,N,8,1	NO	YES
13	2400,N,7,1	2400,N,7,1	YES	-

Based on the data contained in table 12, the number of Data bits configured on the sending or receiving station serial port is only significant if less than seven Data bits are used. The fact that only seven Data bits are required to send all of the required RVR data to ASOS supports this result.

Table 13 indicates the results of tests performed with two communication protocol combinations used with the HP Palmtop and the ASOS. As indicated in the table, RVR data was not detected and displayed on ASOS when the serial ports were set with the same configuration. The protocol analyzer used in the scenario confirmed the HP Palmtop sent properly formatted ADUs. The second protocol combination resulted in the detection and display of RVR data on ASOS even though the protocols did not exactly match. Although the apparent lack of use of the Parity Bit in error detection could explain why the mismatching protocols resulted in successful data transfer, no explanation could be determined for why matching protocols do not have the same result.

TABLE 13. HP PALMTOP-ASOS COMMUNICATION PROTOCOL RESULTS

PROTOCOL	HP PALMTOP	ASOS	RVR DATA DETECTED
1	2400,N,8,1	2400,N,8,1	NO
2	2400,N,8,1	2400,E,7,1	YES

Proper operation of ASOS software version 2.53 was also confirmed with normal operation of the HP Palmtop, i.e., Interim RVR/ASOS Interface, and the New Generation RVR ICCS, i.e., Final RVR/ASOS Interface. Although the ability to properly ingest and display Long-Line RVR data was demonstrated throughout testing, five performance issues were observed and documented. The issues, their impact, and ACT-320 recommendations for resolution are provided in the following paragraphs.

5.1 ISSUE: FALSE NONOPERATIONAL RVR MESSAGE.

The ASOS RVR functional design indicates an RVR Nonoperational message should be displayed when 3 or more minutes of RVR data has not been received by the ASOS. A scenario was observed whereby an RVR Nonoperational message was generated after only 1 minute of RVR data was missing. Although this response was observed during two separate instances, it was not repeatable.

5.1.1 Operational Impact.

No correction of this issue could lead to situations where the ASOS indicates an absence of RVR data when data is actually being provided. Unwarranted outages of Long-Line RVR service could also occur.

5.1.2 Recommendation.

Additional ASOSs operating with software version 2.53 should be monitored for reoccurrences of this problem and the circumstances accompanying it. A software modification should be considered to correct the problem if this performance discrepancy is noted on other systems.

5.2 ISSUE: COMMUNICATION PROTOCOL NOT IN ACCORDANCE WITH ICD.

The communication protocol used by the HP Palmtop, i.e., Interim RVR/ASOS Interface component, currently is 2400 baud, no Parity bit, 8 Data bits and 1 Stop bit. Although this protocol appears to cause no discrepancies in the transmission and reception of RVR data on ASOS, it does not match the ASOS RVR port protocol and is in conflict with the RVR/ASOS ICD (50-SANW-1-00050).

5.2.1 Operational Impact.

Since no RVR/ASOS communication problems can be attributed to the protocol mismatch, this issue currently has no operational impact.

5.2.2 Recommendation.

Since the communication protocol currently used by the HP Palmtop has proved to be a reliable method for transferring RVR data to ASOS, consideration should be given to adding this protocol to the RVR/ASOS ICD.

5.3 ISSUE: COMMUNICATION PROTOCOL MISMATCH NOT DETECTED.

A DCFS was used to create mismatching Parity and Data bit parameters between the ASOS RVR and DCFS serial port. It was observed that for any Parity bit value, i.e., even, none, or odd; 7 or 8 Data bits, and 1 Stop bit, no ASOS communication error was observed for mismatching protocols. However, if less than 7 Data bits were included in the ADU, RVR data were not displayed on ASOS.

5.3.1 Operational Impact.

Since the Parity bit is not used for communication error detection by ASOS RVR software, this problem will most likely have no operational impact as long as detection of erroneous BCC is still achieved. Additionally, a mismatch in the number of Data bits will most likely have no impact as long as the number of Data bits configured is greater than the actual number required for data transmission.

5.3.2 Recommendation.

Due to satisfactory use of the BCC for communication error detection, no additional action is warranted for use of the Parity and Stop bits in error detection.

5.4 ISSUE: RVR FUNCTION REMAINS NONOPERATIONAL ON ASOS.

After reconfiguring the RVR communication port on ASOS, an "RVRNO" message was observed on the ASOS main display screen although RVR data was continually received and displayed on the "12-HR ARCHIVE" and "1-MINUTE DATA" screens. Reconfiguration of the RVR port also resulted in the loss of RVR data on the 1-minute data screen. The RVR Nonoperational message remained even after 10 minutes of data had been restored on the 1-MINUTE DATA screen. New RVR data on the 12-HR archive screen was enclosed with brackets; e.g., [36L45]. An RVR Nonoperational message was not observed in the system log.

5.4.1 Operational Impact.

This problem could result in delays or outages of Long-Line RVR service when no problem exists with the New Generation RVR or RVR/ASOS communication.

5.4.2 Recommendation.

Procedures should be implemented to prevent sustained outages of Long-Line RVR service if the ASOS RVR serial port requires configuration. Additional documentation containing warnings for operator actions could aid in preventing the outages.

5.5 ISSUE: RVR/ASOS COMMUNICATION FAILURE.

The HP Palmtop communication protocol is limited to 2400 baud, no Parity, 8 Data bits and 1 Stop bit. To resolve an apparent mismatch with the ASOS, a test was performed to determine if communication between the HP Palmtop and the ASOS would be successful, if the ASOS RVR port settings were modified to match the HP Palmtop. Although ASOS ADUs were observed on the protocol analyzer, no RVR data were displayed as received on the ASOS. During a similar test with an ASOS ADU generator, communication was established, i.e., transmitted data was observed using the 2400 baud, no Parity, 8 Data bits, and 1 Stop bit protocol.

5.5.1 Operational Impact.

Since an existing combination of communication protocols has been reliable for transmitting and receiving RVR data, this problem has no operational impact as long as the current protocol combination can be used.

5.5.2 Recommendation.

Additional research should be performed to determine the reason for the communication problem.

6. CONCLUSION.

Successful operation of the Automated Surface Observing System (ASOS) Acquisition Control Unit (ACU) software version 2.53 with the Interim and Final Phase Runway Visual Range (RVR)/ASOS Interface suggests this version is suitable for Long-Line RVR reporting at designated Federal Aviation Administration (FAA) and National Weather Service (NWS) locations. Although some performance anomalies were detected during testing, methods to correct and/or avoid the problem appear to exist. As a result, locations receiving software, Version 2.53, should expect reliable performance for Long-Line RVR reporting.

7. RECOMMENDATIONS.

Deployment of Automated Surface Observing System (ASOS) Acquisition Control Unit (ACU) software, Version 2.53, is recommended by ACT-320 at locations designated by the Federal Aviation Administration (FAA) and National Weather Service (NWS). Although deployment is recommended, work should also be performed to correct unresolved issues documented in this report and related issues discussed in previously released reports. If required, additional software modifications should be considered to correct other unresolved problems.

8. ACRONYMS.

AC	Alternating Current
ACU	Acquisition Control Unit
ADAS	Automated Weather Observing System Data Acquisition System
ADU	Application Data Unit
ALS	Ambient Light Sensor
ASOS	Automated Surface Observing System
AWOS	Automated Weather Observing System
BCC	Block Check Code
CD	Controller Display
DCE	Data Communication Equipment
DCFS	Data Communication Fault Simulator
DPU	Data Processing Unit
DTE	Data Terminal Equipment
EIA	Electronics Industries Association
ETX	End of Text
EU	External User
FAA	Federal Aviation Administration
FSS	Flight Service Station
HP	Hewlett Packard
ICCC	Intelligent Communication Controller Card
ICD	Interface Control Document
ID	Identification
MEM	Memphis International Airport
METAR	Aviation Routine Weather Report
MDT	Maintenance Data Terminal
MPU	Maintenance Processor Unit
NDB+1	National Deployment Baseline version 1
NWS	National Weather Service
OID	Operator Information Display
OT&E	Operational Test and Evaluation
PC	Personal Computer
PPU	Product Processing Unit
PROD	Product
RLIM	Runway Light Intensity Monitor
RS	Required Standard
RVR	Runway Visual Range
RWYID	Runway Identifier
SAO	Surface Aviation Observation
SIE	Sensor Interface Electronics
SOH	Start Of Header
STX	Start of Text
VS	Visibility Sensor

APPENDIX A
TEST TROUBLE REPORTS

RVR/ASOS INTERFACE TEST TROUBLE REPORT			TTR-001
DATE: 04/15/98	TIME:	SITE: MEMPHIS	
SYSTEMS/COMPONENTS IN ISSUE:			
RVR DPU <input type="checkbox"/>	RVR MDT <input type="checkbox"/>	ASOS ACU <input checked="" type="checkbox"/>	
RVR SIE <input type="checkbox"/>	INTERIM INTERFACE <input type="checkbox"/>	ASOS DISPLAY <input type="checkbox"/>	
RVR CD <input type="checkbox"/>	FINAL INTERFACE <input type="checkbox"/>	MPS <input type="checkbox"/>	
TEST EQUIPMENT USED:			
PROTOCOL ANALYZER <input checked="" type="checkbox"/>			
OTHER: PC based ASOS ADU generator			
TEST PLAN ID: 4.4.1			
TEST PROCEDURE ID: A.1		STEP(S): 30 – 33	
DESCRIPTION OF ISSUE/PROBLEM: "FALSE NON-OPERATIONAL RVR MESSAGE"			
<p>An RVR "Non-Operational message was observed on the ASOS "1-Minute Data" screen after 1-minute of missing RVR data was observed on the "12 HR Archive" screen. Normally 3-minutes of missing RVR data is required to generate the RVR non-operational message. Although this discrepancy could not be consistently reproduced during testing, it was observed during two separate instances. Reference the attached data sheets.</p>			
NEW GENERATION RVR SOFTWARE VERSION ID: 5.0 (NDB + 1)			
ASOS SOFTWARE VERSION ID: 2.53			
INTERIM RVR/ASOS SOFTWARE ID: 1.1			
Michael Jones and Mark Vassalotti		04/15/98	
ISSUE/PROBLEM WITNESS		DATE	
Michael Jones		04/15/98	
FAA TEST DIRECTOR/REPRESENTATIVE		DATE	
NWS REPRESENTATIVE		DATE	
NOAA REPRESENTATIVE		DATE	

ASOS OID Printout follows:

15:10:38 04/15/98 2110Z

MEMPHIS INTERNATIONAL AIRPORT

UTC	VIS1	D/N1	VIS2	D/N2	VIS3	D/N3	WIND	DIR/SPD	5SEC	WIND	RVR
2020	.177	D			.077	D	183	20	193	22	36L60+
2021	.172	D			.073	D	185	19	178	21	36L60+
2022	.173	D			.067	D	187	19	181	22	36L60+
2023	.174	D			.076	D	193	19	198	20	36L60+
2024	.182	D			.076	D	196	19	197	22	36L60+
2025	.177	D			.074	D	190	20	193	25	36L60+
2026	.177	D			.070	D	186	22	193	26	36L60+
2027	.178	D			.069	D	190	22	184	24	36L60+
2028	.179	D			.074	D	193	21	202	22	36L60+
2029	.176	D			.068	D	196	19	206	23	M
2030	.179	D			.071	D	200	18	210	20	02L01
2031	.178	D			.074	D	202	18	196	18	02L03

12 HR ARCHIVE

ASOS OID Printout follows:

15:11:46 04/15/98 2111Z

MEMPHIS INTERNATIONAL AIRPORT

04/15/98 11:29 *ST 1406 RVR INOPERATIONAL
04/15/98 13:57 *ST 1407 RVR OPERATIONAL
04/15/98 14:30 *ST 1406 RVR INOPERATIONAL
04/15/98 14:39 *ST 1407 RVR OPERATIONAL

COMMUNICATIONS LOG

RVR/ASOS INTERFACE TEST TROUBLE REPORT			TTR-002
DATE: 04/15/98	TIME:	SITE: MEMPHIS	
SYSTEMS/COMPONENTS IN ISSUE:			
RVR DPU <input type="checkbox"/>	RVR MDT <input type="checkbox"/>	ASOS ACU <input type="checkbox"/>	
RVR SIE <input type="checkbox"/>	INTERIM INTERFACE <input checked="" type="checkbox"/>	ASOS DISPLAY <input type="checkbox"/>	
RVR CD <input type="checkbox"/>	FINAL INTERFACE <input type="checkbox"/>	MPS <input type="checkbox"/>	
TEST EQUIPMENT USED:			
PROTOCOL ANALYZER <input checked="" type="checkbox"/>			
OTHER:			
TEST PLAN ID: 4.4.2			
TEST PROCEDURE ID: A.2 STEP(S):			
DESCRIPTION OF ISSUE/PROBLEM: "COMMUNICATION PROTOCOL NOT IN ACCORDANCE WITH INTERFACE CONTROL DOCUMENT (ICD)"			
The communication protocol used by the Interim RVR/ASOS Interface i.e. HP Palmtop, is 2400 baud, no parity, 8 data bits and 1 stop bit. Although this communication protocol appears to cause no discrepancies in the transmission and reception of data on the ASOS, it is in conflict with the protocol used on the ASOS RVR port and the RVR-ASOS ICD (50-SANW-1-00050). The ASOS RVR port uses the following communication protocol 2400 baud, even parity, 7 data bits and 1 stop bit.			
NEW GENERATION RVR SOFTWARE VERSION ID: 5.0 (NDB + 1)			
ASOS SOFTWARE VERSION ID: 2.53			
INTERIM RVR/ASOS SOFTWARE ID: 1.1			
Mark Vassalotti and Michael Jones		04/15/98	
ISSUE/PROBLEM WITNESS		DATE	
Michael Jones		04/15/98	
FAA TEST DIRECTOR/REPRESENTATIVE		DATE	
NWS REPRESENTATIVE		DATE	
NOAA REPRESENTATIVE		DATE	

RVR/ASOS INTERFACE TEST TROUBLE REPORT		TTR-003
DATE: 04/16/98	TIME: 11:30 AM	SITE: MEMPHIS
SYSTEMS/COMPONENTS IN ISSUE:		
RVR DPU <input type="checkbox"/>	RVR MDT <input type="checkbox"/>	ASOS ACU <input checked="" type="checkbox"/>
RVR SIE <input type="checkbox"/>	INTERIM INTERFACE <input type="checkbox"/>	ASOS DISPLAY <input type="checkbox"/>
RVR CD <input type="checkbox"/>	FINAL INTERFACE <input type="checkbox"/>	MPS <input type="checkbox"/>
TEST EQUIPMENT USED: PC-based ASOS Generator		
PROTOCOL ANALYZER <input checked="" type="checkbox"/>		
OTHER:		
TEST PLAN ID: 4.4.2		
TEST PROCEDURE ID: A.2 STEP(S):		
DESCRIPTION OF ISSUE/PROBLEM: "COMMUNICATION PROTOCOL MISMATCH"		
NOT DETECTED"		
Simulated communication errors within the ASOS Application Data Unit (ADU) data frame resulted in no error detection on ASOS. An ASOS ADU generator was used to create mismatching parity and data bit parameters between the ASOS RVR communication port and the transmitted ASOS ADU. For example, an ADU with no parity and 8 data bits was Transmitted from ADU generator to the ASOS RVR port configured with even parity and 7 data bits. It was observed that for any parity bit value i.e. even, none, odd; 7 or 8 data bits, and 1 stop bit, no error would be observed for mismatching communication protocols. However, if less than 7 data bits were included in the ADU, the RVR data would not be Displayed on ASOS.		
NEW GENERATION RVR SOFTWARE VERSION ID: 5.0 (NDB + 1)		
ASOS SOFTWARE VERSION ID: 2.53		
INTERIM RVR/ASOS SOFTWARE ID: 1.1		
Mark Vassalotti and Michael Jones	04/16/98	
ISSUE/PROBLEM WITNESS		DATE
Michael Jones	04/16/98	
FAA TEST DIRECTOR/REPRESENTATIVE		DATE
NWS REPRESENTATIVE		DATE
NOAA REPRESENTATIVE		DATE

RVR/ASOS INTERFACE TEST TROUBLE REPORT			TTR-004
DATE: 04/16/98	TIME:	SITE: MEMPHIS	
SYSTEMS/COMPONENTS IN ISSUE:			
RVR DPU <input type="checkbox"/>	RVR MDT <input type="checkbox"/>	ASOS ACU <input checked="" type="checkbox"/>	
RVR SIE <input type="checkbox"/>	INTERIM INTERFACE <input type="checkbox"/>	ASOS DISPLAY <input type="checkbox"/>	
RVR CD <input type="checkbox"/>	FINAL INTERFACE <input type="checkbox"/>	MPS <input type="checkbox"/>	
TEST EQUIPMENT USED:			
PROTOCOL ANALYZER <input checked="" type="checkbox"/>			
OTHER:			
TEST PLAN ID: 4.4.2			
TEST PROCEDURE ID: A.2		STEP(S):	
DESCRIPTION OF ISSUE/PROBLEM: "ASOS RVR FUNCTION REMAINS NON-OPERATIONAL"			
After reconfiguring the ASOS RVR communication port, an "RVRNO" message was seen on the main display screen although RVR data was continually received and displayed on the 12 HR archive and 1-minute data screens. Reconfiguration of the RVR port also resulted in the loss of RVR data on the 1-minute data screen. The RVR non-operational remained after 10 minutes of data had been restored on the 1-minute data screen. New RVR data observed on the 12 HR archive screen was enclosed with brackets e.g. [36L45]. An RVR Non-Operational message was not observed in the system log. See data.			
NEW GENERATION RVR SOFTWARE VERSION ID: 5.0 (NDB + 1)			
ASOS SOFTWARE VERSION ID: 2.53			
INTERIM RVR/ASOS SOFTWARE ID: 1.1			
Mark Vassalotti and Michael Jones		04/16/98	
ISSUE/PROBLEM WITNESS		DATE	
Michael Jones		04/16/98	
FAA TEST DIRECTOR/REPRESENTATIVE		DATE	
NWS REPRESENTATIVE		DATE	
NOAA REPRESENTATIVE		DATE	

04/16/98 10:09 *ST 1407 RVR operational
 04/16/98 10:09 *ST 1964 ADAS-ASOS link established
 04/16/98 10:09 *ST 1966 ADAS port is ADAS PRIMARY

ASOS OID Printout follows:

10:12:47 04/16/98 1612Z MEMPHIS INTERNATIONAL AIRPORT

UTC	VIS1	D/N1	VIS2	D/N2	VIS3	D/N3	WIND	DIR/SPD	5SEC	WIND	RVR
1601	.311	D			.289	D	216	13	218	16	M
1602	.309	D			.287	D	217	13	223	16	27L50
1603	.307	D			.292	D	215	14	209	20	27L50
1604	.308	D			.290	D	218	16	218	16	27L50
1605	.311	D			.291	D	221	14	226	17	27L50
1606	.309	D			.295	D	220	14	227	16	27L50
1607	.314	D			.286	D	223	15	226	17	27L50
1608	.308	D			.283	D	217	16	211	19	27L50
1609	.304	D			.280	D	215	17	222	19	27L50
1610	.302	D			.285	D	222	15	216	17	27L50
1611	.295	D			.284	D	225	13	224	15	[27L26]
1612	.306	D			.298	D	217	13	208	18	[27L50]

12 HR ARCHIVE

ASOS OID Printout follows:

10:27:28 04/16/98 1627Z MEMPHIS INTERNATIONAL AIRPORT

ASOS 1-MINUTE SCREEN:

SKY = FEW020 SCT26 SCT060

VISIBILITY = 1/4SM TEMP/DEWPT = 24.4/20.6 C 76/69 F
 RVR = RVRNO WIND DIR/SPD = 210/13G20
 PRESENT WX= HZ ALTIMETER = 29.65

REMARKS = RMK AO2 TSNO RVRNO

TESTM KMEM 161553Z 22013KT 1/4SM R27/2600V5000FT HZ SCT020 SCT035
 24/21 A2966 RMK AO2 SLP039 T0244026 \$

MAG WIND DIR/SPD: 210/12G20

RELATIVE HUMIDITY: 78 STATION PRESSURE: 29.34
 PRESSURE ALTITUDE: 590

SEA LVL PRESSURE: 1003.5

DENSITY ALTITUDE: 1900

ASOS OID Printout follows:

10:27:55 04/16/98 1627Z

MEMPHIS INTERNATIONAL AIRPORT

1-MINUTE CURRENT SENOR DATA

UTC	VIS1	D/N1	VIS2	D/N2	VIS3	D/N3	TEMP	DEWPT	5SEC	WIND	RVR
1618	6.07	D			6.23	D	76	69	196	15	27L50
1619	6.05	D			6.21	D	76	69	199	15	27L50
1620	6.01	D			6.19	D	76	69	227	13	27L26
1621	6.03	D			6.13	D	76	69	211	13	27L50
1622	5.94	D			6.03	D	76	69	218	12	27L50
1623	6.11	D			6.01	D	76	68	196	12	27L50
1624	6.13	D			6.26	D	77	69	224	18	27L50
1625	6.17	D			6.43	D	77	69	202	20	27L26
1626	6.11	D			6.36	D	76	68	223	16	27L50
1627	6.11	D			6.45	D	76	69	204	14	27L50

CURRENT

PRECIPITATION AMOUNT (HOUR): 0.00 IN
WATER EQUIVALENT (HOUR): M IN
CURRENT SNOW DEPTH: M IN

RVR/ASOS INTERFACE TEST TROUBLE REPORT		TTR-005
DATE: 04/16/98	TIME:	SITE: MEMPHIS
SYSTEMS/COMPONENTS IN ISSUE:		
RVR DPU <input type="checkbox"/>	RVR MDT <input type="checkbox"/>	ASOS ACU <input checked="" type="checkbox"/>
RVR SIE <input type="checkbox"/>	INTERIM INTERFACE <input checked="" type="checkbox"/>	ASOS DISPLAY <input type="checkbox"/>
RVR CD <input type="checkbox"/>	FINAL INTERFACE <input type="checkbox"/>	MPS <input type="checkbox"/>
TEST EQUIPMENT USED: PC-based ASOS ADU generator		
PROTOCOL ANALYZER <input checked="" type="checkbox"/>		
OTHER:		
TEST PLAN ID:		
TEST PROCEDURE ID: STEP(S):		
DESCRIPTION OF ISSUE/PROBLEM: "RVR-ASOS COMMUNICATION FAILURE"		
Since the HP Palmtop communication protocol is limited to 2400 baud, no parity, 8 data bits and 1 stop bit, a test was performed to determine if communication between the HP Palmtop and the ASOS could exist if the ASOS RVR port settings were modified to match the HP Palmtop. Although ASOS ADUs were observed on the protocol analyzer, no RVR data was displayed as received on the ASOS. During a similar test with an ASOS ADU generator, communication was established i.e. transmitted data was observed using the 2400, N, 8, 1, protocol.		
NEW GENERATION RVR SOFTWARE VERSION ID: 5.0 (NDB + 1)		
ASOS SOFTWARE VERSION ID: 2.53		
INTERIM RVR/ASOS SOFTWARE ID: 1.1		
Michael Jones	04/16/98	
ISSUE/PROBLEM WITNESS	DATE	
Michael Jones	04/16/98	
FAA TEST DIRECTOR/REPRESENTATIVE	DATE	
NWS REPRESENTATIVE	DATE	
NOAA REPRESENTATIVE	DATE	