

343051

JPRS-CST-88-020

28 SEPTEMBER 1988



**FOREIGN
BROADCAST
INFORMATION
SERVICE**

JPRS Report

Science & Technology

China

19981204 116

DTIC QUALITY INSPECTED 2

Reproduced From
Best Available Copy

10
84
A05

SCIENCE & TECHNOLOGY

CHINA

CONTENTS

SCIENCE & TECHNOLOGY POLICY

"Science & Technology Town" Set Up in Chongqing [SICHUAN RIBAO, 15 Aug 88]	1
Experts Study High Polymers Produced by Laser-Catalyst Method [RENMIN RIBAO, 26 Jul 88]	3

AEROSPACE

Non-Oscillatory, Non-Free-Parameter Dissipation Difference Scheme [Zhang Hanxin; KONGQIDONGLIXUE XUEBAO, No 2, Jun 88]	5
Calculation of Unsteady Transonic Flows With Large Longitudinal Disturbance About Airfoils Including Viscous Effects [Ang Haisong; KONGQIDONGLIXUE XUEBAO, No 2, Jun 88]	6
Numerical Computation of Transonic Non-Isentropic Potential Equations [Xu Jianzhong, et al.; KONGQIDONGLIXUE XUEBAO, No 2, Jun 88]	7
Numerical Study of Incompressible Viscous Flow Over Isolated Airfoil [Gu Chuangang, et al.; KONGQIDONGLIXUE XUEBAO, No 2, Jun 88]	8
Experimental Study of Laminar Boundary Layer Instability, Transition [Zhou Mingde; KONGQIDONGLIXUE XUEBAO, No 2, Jun 88]	9

Application of Color Helium Bubble in Wind Tunnel Test [Zhao Dong, et al.; KONGQIDONGLIXUE XUEBAO, No 2, Jun 88]	10
Calculation of Pitching Damping Derivatives of Bodies of Revolution in Low Hypersonic Flows [Zhu Keqin, et al.; KONGQIDONGLIXUE XUEBAO, No 2, Jun 88]	11
Once Subject of Speculation, F-12 Found Relegated to Air Museum [HANGKONG ZHISHI, No 8, Aug 88]	12
Satellite Orbital Determination Precision Reaches Meter Level [Zou Guoliang, Gu Longyou; WEN HUI BAO, 21 Aug 88]	15

ADVANCED MATERIALS

Simple Method for Solving Direct Problems of 3-D Flow in Axial Turbomachinery [Zhao Xiaolu; GONGCHENG REWULI XUEBAO, No 3, Aug 88]	16
Stable, Intensified Combustion of Pulverized Coal, CWS Utilizing Multi-Annular Opposing Distributing Jets [Zhao Huifu, et al.; GONGCHENG REWULI XUEBAO, No 3, Aug 88]	17
Experimental Study of Distributions at Exit of Turbojet Afterburner Using Gas Analysis System [Han Yixiang, et al.; GONGCHENG REWULI XUEBAO, No 3, Aug 88]	18

BIOTECHNOLOGY

Structural, Immunological Studies of Lipoprotein From Outer Membrane of <u>Morganella morganii</u> [Huang Yaoxuan, et al.; ZHONGHUA WEISHENGWUXUE HE MIANYIXUE ZAZHI, No 3, Jun 88]	19
Assay of Beta-Adrenergic Receptors on Mouse Spleen Cells by H-dihydroalprenolol Binding [Zhou Jiannian, et al.; ZHONGHUA WEISHENGWUXUE HE MIANYIXUE ZAZHI, No 3, Jun 88]	20
Study of Biotin Labeled <u>Campylobacter</u> Chromosome DNA Probe [Zhou Yongtai, et al.; ZHONGHUA WEISHENGWUXUE HE MIANYIXUE ZAZHI, No 3, Jun 88]	21
Isolation, Purification, Chemical Analysis of Rough Lipopolysaccharide of <u>Salmonella typhimurium</u> SL 1102 [Jiao Binghua, et al.; ZHONGHUA WEISHENGWUXUE HE MIANYIXUE ZAZHI, No 3, Jun 88]	22

Establishment, Identification of Genus Specific McAb Against Salmonella [Zhao Weiguo, et al.; ZHONGHUA WEISHENGWUXUE HE MIANYIXUE ZAZHI, No 3, Jun 88]	23
Early T Cells Induced In Vitro To Exert Specific Cytotoxicity to Target Cells [Chen Weifeng; ZHONGHUA WEISHENGWUXUE HE MIANYIXUE ZAZHI, No 3, Jun 88]	24
Chronic Asymptomatic Hepatitis B Virus Infection, Reactivity of Tuberculin Skin Test [Luo Kangxian, et al.; ZHONGHUA WEISHENGWUXUE HE MIANYIXUE ZAZHI, No 3, Jun 88]	25
Isolation, Bioactivity Assay of Plasma Non-Specific Immunosuppressive Proteins of Pigs (PNIP) [Geng Yongjian, et al.; ZHONGHUA WEISHENGWUXUE HE MIANYIXUE ZAZHI, No 3, Jun 88]	26
Studies of Biological Properties of Chemical Vaccine Prepared From Antigenic Fractions of <u>Vibrio cholerae</u> [Zheng Zhenxi, et al.; ZHONGHUA WEISHENGWUXUE HE MIANYIXUE ZAZHI, No 3, Jun 88]	27
Quick Propagation of Pathogenic Salmonella Bacteria [Xing Nianyi, Li Haixia; WEISHENGWUXUE TONGBAO, No 3, Jun 88]	28
Studies on Tick-Borne Encephalitis Virus Genome RNA Isolation and Property [Yang Peiyong, et al.; WEISHENGWUXUE TONGBAO, No 3, Jun 88]	29
Briefs	
Third Generation Snake Toxin Preparation	30
Gene Engineering Human Growth Hormone	30
Producing Root Nodules in Non-Legume Plants	30
Super Low-Temperature Pollen Preservation	31

COMPUTERS

Memory Hierarchical Structure in the AI Computer LISP-M1 [Shan Degen, et al.; XI'AN JIAOTONG DAXUE XUEBAO, No 3, Jun 88]	32
Design and Implementation of a List Processor in LISP Machine LISP-M1 [Qian Depei, et al.; XI'AN JIAOTONG DAXUE XUEBAO, No 3, Jun 88]	33

Compact List Representation and Its Implementation on LISP Machine LISP-M1 [Zhao Yinliang, et al.; XI'AN JIAOTONG DAXUE XUEBAO, No 3, Jun 88]	34
Investigation of Implementation of Evaluator on LISP Machine LISP-M1 [Dai Donglai, et al.; XI'AN JIAOTONG DAXUE XUEBAO, No 3, Jun 88]	35
Status, Future Prospects for CAD [Fang Jiaqi; JISUANJI SHIJIE, No 25, 29 Jun 88]	36
Software System for Digital Processing of Clouded Images [JISUANJI SHIJIE, No 29, 27 Jul 88]	40
Briefs	
CAS Acoustics Institute's Signal Processors	41
Digital Signal Processing Board	41
Large-Screen Plasma Display System	41
Multiple-Font Character Recognition System	42
Sino-American Joint Venture	42
Japanese Software Firm Formed in Beijing	43
New Computer Institute Formed	43
Defense Data Processing System	43
 FACTORY AUTOMATION, ROBOTICS	
Recent Developments in Flexible Manufacturing Systems, Robotics	
FMS Simulation System [JISUANJI SHIJIE, 8 Jun 88]	44
Largest Domestic FMS Passes Test [Liang Yanfu; ZHONGGUO JIXIE BAO, 16 Jun 88]	45
Beijing Robotics Research [Ze Honglin; JISUANJI SHIJIE, 22 Jun 88]	45
Development of Robotics Urged [Meng Xiangjie; RENMIN RIBAO, 22 Jul 88]	48
 LASERS, SENSORS, OPTICS	
Time-Resolved Fluorescence, Energy Transfer of Cu ⁺ -Doped Fluorophosphate Glass [Liu Huimin, et al.; GUANGXUE XUEBAO, No 6, Jun 88]	50
Resonance Ionization Spectra of Ba ₂ Excimer, Study of Ionization Mechanism [Wu Donghong, et al.; GUANGXUE XUEBAO, No 6, Jun 88]	51
Four-Level Atomic System Resonantly Pumped by Double-Wave Fields* [Luo Gengxian, et al.; GUANGXUE XUEBAO, No 6, Jun 88] ...	52

Raman Beam Cleanup of Excimer Laser Radiation*	
[Luo Qihong, et al.; GUANGXUE XUEBAO, No 6, Jun 88]	53
New Method for Establishing 3-D Optical Diffraction Integrals for Focusing Optical Systems	
[Ruan Yu, et al.; GUANGXUE XUEBAO, No 6, Jun 88]	54
New Method for Interference Fringe Scanning	
[Cai Bo; GUANGXUE XUEBAO, No 6, Jun 88]	55
Wave-Scanning Inverse WKB Method for Refractive Index Profile Determination of Monomode Planar Optical Waveguide With Graded Index Refraction	
[Pu Yuan, et al.; GUANGXUE XUEBAO, No 6, Jun 88]	56
Experimental Study of Optical Second Harmonic Generation of Langmuir-Blodgett Monolayer Assembly	
[Chen Gang, et al.; GUANGXUE XUEBAO, No 6, Jun 88]	57
Preparation of Multilayer Soft X-Ray Mirrors	
[Zheng Tianshui, et al.; GUANGXUE XUEBAO, No 6, Jun 88]	58
Design, Measurement of Quasi-Optical Millimeter-Wave System for Plasma Diagnostics	
[Shen Xuemin, Wang Zhaoshen; DIANZI KEXUE XUEKAN, No 4, Jul 88]	59
Theory of Synchronously Pumped Mode-Locking Dye Lasers	
[Bao Xiaoyi, et al.; GUANGXUE XUEBAO, No 7, Jul 88]	62
Anisotropy of Ion Emissions in Laser-Plasma Interaction	
[Sun Lan, et al.; GUANGXUE XUEBAO, No 7, Jul 88]	63
Investigation of Dislocation Properties, Motion in YAG by Means of X-Ray Transmission Topography With Agk_{α} Radiation	
[Deng Peizhen, et al.; GUANGXUE XUEBAO, No 7, Jul 88] ...	64
Study of Defects in Nd:YAG Crystals by Darkfield and Phase Contrast Microscopy	
[Deng Peizhen, et al.; GUANGXUE XUEBAO, No 7, Jul 88] ...	65
Photoacoustic Study of Spectral Absorption of Optical Films	
[Jin Gang, et al.; GUANGXUE XUEBAO, No 7, Jul 88]	66
Briefs	
New Military Radar System	67
New Air Force Camera	67

MICROELECTRONICS

Novel CMOS Memory Elements Based on Pass Transistors
[Wu Xunwei; HANGZHOU DAXUE XUEBAO, No 3, Jul 88] 68

Briefs
All-Chinese-Made Super Clean Room 71

TELECOMMUNICATIONS R&D

Fast Evaluation of Characteristics of Single-Mode Optical Fibers
[Yang Xianglin; DIANZI KEXUE XUEKAN, No 4, Jul 88] 72

Highly Stabilized GaAs FET Oscillator Using Dielectric
Resonator Feedback Circuits
[Gu Molin; DIANZI XUEBAO, No 4, Jul 88] 73

Briefs
Satellite Earth Station Extension 75
Beijing-Shenyang-Harbin Fiber-Optic Line 75
Zhengzhou-Wuhan Fiber-Optic Line 75
Weifang To Import Digital Switchboard 76

/19986

"Science & Technology Town" Set Up in Chongqing

[Editorial Report] 40080006a Chengdu SICHUAN RIBAO in Chinese on 15 August 1988 carries on page 1 a 550-word report (including a 135-word editor's note) on a new "scientific, technological and industrial development experimental zone" approved by the Chongqing government and taking shape in a 16-sq-km area of the city's 117-sq-km Shapingba district. S&T development enterprises registered in the zone will receive favorable treatment from the district government (see report from Beijing XINHUA in English in FBIS-CHI-88-162, 22 Aug 88, p 44). The report includes the following passage:

"The Shapingba district is Chongqing's talent-intensive and technology-intensive area. It has 12 institutions of higher education and several ministerial, provincial and municipal scientific research institutions and large-to-mid-sized enterprises. To promote the establishment of the S&T development zone, the Shapingba district government will assume a policy of preferential treatment in the following seven ways:

(1) Taxing policy. Whole-people-owned and collective S&T development enterprises newly formed within the experimental zone are totally exempt from [state] taxes for the first 3 years, and for the fourth through sixth years their taxes will be reduced by half. (2) Pricing policy. For a trial-sale period of 2 years, S&T development enterprises may set their own new-product prices. (3) Preferential foreign trade. The municipal foreign trade office will give special consideration to matters of export product trade for S&T development firms. All of the foreign exchange earned, with the exception of the 20 percent due the state, may remain with the S&T enterprises or may be deposited with the Bank of China. (4) Preferred credit. Other conditions being equal, all specialized banks will give priority in loans to S&T development enterprises. (5) Development funds. For the next 6 years, the city will permit the district to retain all taxes paid by S&T development enterprises in the experimental zone in order to create S&T development funds for supporting the

growth of S&T development enterprises in the experimental zone. (6) Preferential location. S&T development enterprises can have precedence in subleasing storefront space in the heart of the Shapingba district. (7) Measures to safeguard [delivery of] goods and materials. State-controlled goods and materials, and water, electricity, gas, and coal required by the S&T development enterprises will be preferentially assigned to those enterprises on the condition that the amounts not exceed district quotas.

"At present, the registrations of 40 S&T development enterprises have been examined and approved; another 90 are in process. The original 31 locally run S&T firms operating in the zone must undergo a new investigation in order to enjoy the preferential policies."

/9274

Experts Study High Polymers Produced by Laser-Catalyst Method

40080006b Beijing RENMIN RIBAO in Chinese 26 Jul 88 p 3

[Excerpts] A research team of the Institute of Physics of the Chinese Academy of Sciences is now using a laser-catalyst method to produce high polymer materials. Fu Kejian, in charge of these researchers, said that the first step would lay stress on the investigation into whether this method could, under normal temperatures and pressures, synthesize polymers, determine [physical] laws [involved], and the research mechanisms.

After more than a year's work, the team has already achieved positive results. Using laser excitation on certain metallic and organic chemical compounds, they have achieved molecule excitation and separation. Through chemical analysis and laser appraisal, they created a truly new polymer.

Modern polymer materials have already found application in science and technology fields, in industrial sectors, and people's daily lives. Some heat-resistant, super-hard, lightweight new polymer materials have replaced metallic materials for such uses as replacements for human organs, certain spacecraft parts and satellite assembly. Microelectronics, information science, and new energy sources would be possible without high polymer materials. The research team has provided statistical proof that by using the laser-catalyst method, high polymer materials can be processed under conditions of normal temperatures and pressures quickly, simply, and with a higher monomer exchange ratio. By adjusting the laser's energy, frequency, and wavelength, it is possible to obtain high polymer materials with different molecular weight. This is virtually impossible in today's conventional thermo-chemical reaction.

Fu Kejian's research team's work is highly regarded by authoritative persons in chemistry circles. They are of the opinion that this project is opening up new paths. But some

experts point out that the use of lasers in the chemical industry has no future, that the high cost of making the lasers will make production costs soar.

Researchers of the Institute of Chemistry of the Chinese Academy of Sciences are holding out for the project and it is understood that the results of this work will nevertheless be announced for the first time internationally.

/9274

Non-Oscillatory, Non-Free-Parameter Dissipation Difference Scheme

40090132a Mianyang KONGQIDONGLIXUE XUEBAO [ACTA AERODYNAMICA SINICA]
in Chinese Vol 6 No 2, Jun 88 pp 143-165

[English abstract of article by Zhang Hanxin [1728 3211 0207] of China
Aerodynamics Research and Development Center]

[Text] Through a model study, the spurious oscillations occurring near shock waves with finite difference equations have been found to be related to the dispersion terms in the corresponding modified differential equation. If the signs of the dispersion coefficients are properly adjusted so that the signs change across the waves, the undesirable oscillations can be totally suppressed. This fact is in conformity with the requirement of the second law in thermodynamics, i.e., with this artifice, the entropy of a heat isolated system increases.

Based on the above findings, an efficient finite difference scheme has been developed which, in fact, is a "TVD" scheme, although much simpler. The author's scheme is related to Godunov's, and may be regarded as its extension.

Finally, the numerical results of two- and three-dimensional flows are given using these numerical schemes. It is shown that the algorithm is efficient and sound.

9717

Calculation of Unsteady Transonic Flows With Large Longitudinal Disturbance
About Airfoils Including Viscous Effects

40090132b Mianyang KONGQIDONGLIXUE XUEBAO [ACTA AERODYNAMICA SINICA]
in Chinese Vol 6 No 2, Jun 88 pp 166-173

[English abstract of article by Ang Haisong [2491 3189 2646] of Nanjing
Aeronautical Institute]

[Text] A new method for calculating steady and unsteady transonic flows with large longitudinal disturbance and small transverse disturbance has been developed. The viscous effects can be studied with this method, including the boundary layer displacement thickness and the shock-boundary layer interaction. The ADI algorithm of the monotone switch method and the nonreflecting far field condition are used, and the computational efficiency is high.

9717

Numerical Computation of Transonic Non-Isentropic Potential Equations

40090132c Mianyang KONGQIDONGLIXUE XUEBAO [ACTA AERODYNAMICA SINICA]
in Chinese Vol 6 No 2, Jun 88 pp 174-181

[English abstract of article by Xu Jianzhong [1776 1696 0022], et al., of the
Institute of Engineering Thermophysics, Chinese Academy of Sciences]

[Text] Based on the analysis of the momentum equations and non-isentropic flow, an "isentropic density" ρ_i , which is computed according to the isentropic relation and is only dependent on the temperature, is separated from the entropy variation, and the entropy increase across the shock may be directly calculated from the momentum equations in the divergent form. Iterating it with the classical potential equation may solve the non-isentropic transonic flowfield conveniently. It is seen from the calculations of transonic cascade flow on the surface of revolution that the shock in the non-isentropic calculation is placed further upstream and is weaker than that of the classical potential solution. In the calculation, the effect of the entropy increase on the Kutta condition and the outlet boundary condition is taken into consideration.

9717

Numerical Study of Incompressible Viscous Flow Over Isolated Airfoil

40090132d Mianyang KONGQIDONGLIXUE XUEBAO [ACTA AERODYNAMICA SINICA]
in Chinese Vol 6 No 2, Jun 88 pp 190-196

[English abstract of article by Gu Chuangang [6253 0278 4854], et al., of
Xi'an Jiaotong University]

[Text] A finite difference method based on a differential-integral equation is presented to solve the Navier-Stokes equations for incompressible viscous flow. This method is applied to solve the turbulent flows past an isolated airfoil at large angles of attack with separations. The $K-\epsilon$ turbulence model, in conjunction with the adverse pressure gradient, is utilized to describe and analyze turbulent flow processes. A modified hybrid scheme and a modified pressure correction formula, suitable for non-orthogonal coordinates, have been developed to make the calculation rapidly convergent and simple. A comparison of calculations and experiments shows that the agreement of calculated results with experimental data is fairly satisfactory with respect to the pressure distribution on the airfoil surface and average velocity field, as well as to the point of separation and Reynolds shear stresses.

9717

Experimental Study of Laminar Boundary Layer Instability, Transition

40090132e Mianyang KONGQIDONGLIXUE XUEBAO [ACTA AERODYNAMICA SINICA]
in Chinese Vol 6 No 2, Jun 88 pp 213-219

[English abstract of article by Zhou Mingde [0719 2494 1795] of Nanjing
Aeronautical Institute]

[Text] An experimental study of the laminar boundary layer instability and transition has been carried out in a flat-plate boundary layer by means of controllable heat pulsing introduced into the critical layer. The main results show that the two-dimensional linear theory worked well during the initial period of disturbance amplification, even when three-dimensional disturbance components existed. In addition, the subharmonic routes to transition were found to start from the lower fluctuation levels of initial disturbances or from lower Reynolds numbers, so are worth noting in artificial transition and the active control of transition.

9717

Application of Color Helium Bubble in Wind Tunnel Test

40090132f Mianyang KONGQIDONGLIXUE XUEBAO [ACTA AERODYNAMICA SINICA]
in Chinese Vol 6 No 2, Jun 88 pp 220-225

[English abstract of article by Zhao Dong [6392 2767], et al., of Harbin
Aerodynamic Research Institute]

[Text] Color helium bubble flow visualization is a new and unique technique. Flow visualization in the wind tunnel using color helium bubbles was achieved at Harbin Aerodynamic Research Institute in March 1984. Rich and varied paths were obtained. Clear color videotape recordings and color photographs were taken. Shortly thereafter, car, coach, building, ship's rudder, fish scale wave surface, slender body, cylinder, parachute and several aircraft models were tested.

This paper describes the color helium bubble flow visualization technique. The general arrangement and basic principle, as well as applications of flow visualization in the wind tunnel, are presented.

9717

Calculation of Pitching Damping Derivatives of Bodies of Revolution in Low Hypersonic Flows

40090132g Mianyang KONGQIDONGLIXUE XUEBAO [ACTA AERODYNAMICA SINICA]
in Chinese Vol 6 No 2, Jun 88 pp 250-254

[English abstract of article by Zhu Keqin [2612 0344 0530], et al., of the University of Science and Technology of China]

[Text] In this paper, the improved second-order shock-expansion method has been extended to calculate the pitching damping derivatives of bodies of revolution. This method is more reasonable than the corrected Newtonian theory since influences of aerodynamic parameters in the forward stream line are taken into account.

The main region researched in this paper is low hypersonic flow. The method is also appropriate for use for supersonic and hypersonic flows. A comparison of the calculated results with experimental ones shows that the calculated results are reasonable and the approximate method is valuable.

9717

Once Subject of Speculation, F-12 Found Relegated to Air Museum

40080008 Beijing HANGKONG ZHISHI [AEROSPACE KNOWLEDGE MAGAZINE] in Chinese No 8, Aug 88 pp 13, 14 and special insert

[Text] On 10 September 1973, Ye Jianying, Li Xiannian, Xu Xiangqian, Nie Rongzhen, and other Party and State leaders, observed a flight demonstration at Beijing's Nanyuan Airbase by what was then the country's hottest new fighter aircraft--the Jian-12 [F-12]. With a short take-off roll, the aircraft was highly maneuverable and adaptable [for various missions].

In 1969, The Chinese Air Force, based on an analysis of the "localized" warfare situation in the world at that time, and on China's strategic considerations, initiated the development of a light medium-to-low-altitude supersonic fighter that would have a short take-off and landing capability and be highly maneuverable with easy maintenance requirements. The developmental work was given to the Nanchang Aircraft Manufacturing Plant. The aircraft was designated the "F-12", and Comrade Lu Xiaopeng was put in charge of the design work.

The F-12 fighter was wholly self-designed. It was a single-seat aircraft with a nose intake and a single turbo jet engine capable of taking off and landing on hard earth strips. Two auxiliary air intakes were located on either side of the fuselage to prevent foreign matter from entering the [main] intake during take-off. The aircraft was fitted with two cannon and three hardpoints were provided on the underside of the wings and fuselage for an auxiliary fuel tank, bombs, and other weaponry. The latest technologies were employed in the construction, such as integral fuel tanks in the wings and fuselage, chemically milled integral panels, metallic honeycomb panels, foamed plastic sandwich structures, titanium alloy tailpipes, aluminum alloy nose landing gear, solid windshields, etc.

After the F-12's overall design lay-out had been approved in August 1969, only 17 months' time was needed to complete the blueprints and the model wind tunnel tests, the strength tests, and the systematic model simulations. In addition, three prototypes were made. The first of these made its test flight on 26 December 1970. After more than 2 years of flight tests, problems were apparent in this aircraft. The Nanchang Aircraft Manufacturing Plant undertook to make 10 major modifications in the design of the F-12. Principal among these changes were:

- 1) The elimination of the central nose cone to reduce the intake loss;
- 2) Stiffening of the waist of the fuselage to improve transonic acceleration;
- 3) To reduce weight, the leading-edge slats were eliminated and the double-slotted wing flaps were changed; and
- 4) The aircraft cannon were placed farther to the rear.

The first of the so modified aircraft took to the air in July 1975. The F-12 was originally intended for large-scale production, but due to such factors as insufficient firepower and engine power and Air Force equipment requirement revisions, developmental work on the aircraft ceased in January 1977. Altogether, six aircraft had been built and 135 flight tests had been conducted (total time: 61 hours, 12 minutes). During its development stage, the F-12 was the focus of work for dozens of organizations and over 100 manufacturing facilities.

Power Plant: One turbojet engine with a maximum thrust of 2,500 kilograms; 4,050 kilograms with afterburning.

Armament: One cannon mounted at each wingroot; provisions for additional armament.

Dimensions [external]: Wing span: 7.2 meters
Length: 10.3 meters
Height: 3.73 meters

Weights: Empty: 3,172 kilograms
Normal operating: 4,530 kilograms
Maximum fuel load: 1,165 kilograms

Performance: Maximum speed (level flight): Mach 1.2 at altitude of 11,000 meters
Maximum rate of climb: 180 meters/second (from altitude of 0 meters)
Service ceiling: 16,870 meters
Maximum range: 688 kilometers (without auxiliary fuel tank)

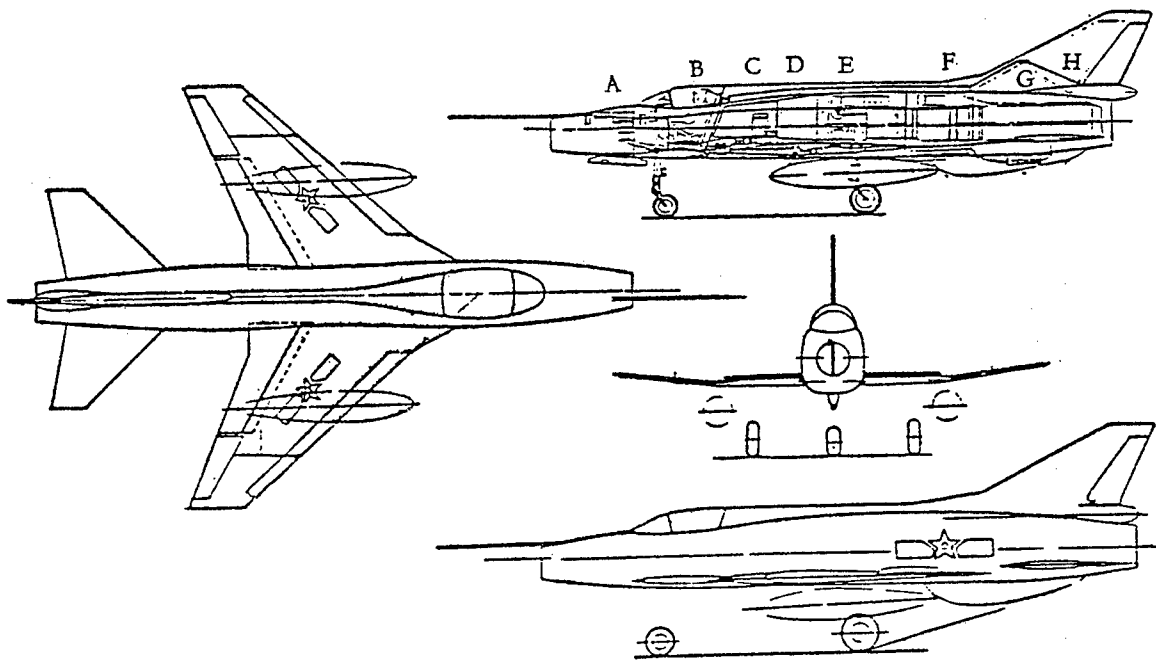
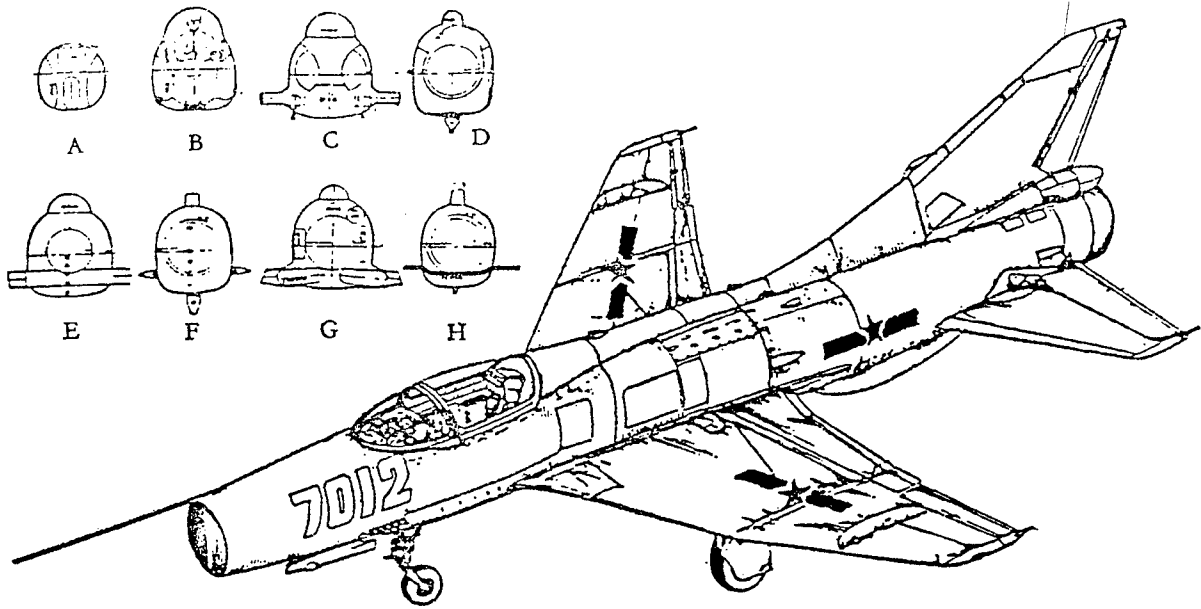

External Aspect and Three-Sided View of F-12

Satellite Orbital Determination Precision Reaches Meter Level

40080004 Shanghai WEN HUI BAO in Chinese 21 Aug 88 p 3

[Article by Zou Guoliang (6760 0948 5328) and Gu Longyou (7357 7893 0645):
"Satellite Orbital Determination Precision Reaches Meter Level--China's
Dynamic Geodetic Satellite Research Ranks Among the World's Most Advanced"]

[Text] Nanjing (Special Report)--China's first dynamic geodetic satellite project--a concerted joint effort by 14 organizations including the Chinese Academy of Sciences, the General Staff's Surveying Bureau, the Commission of Science, Technology and Industry for National Defense, and the Head Office of the State Bureau of Surveying and Cartography--has resulted in improving the precision with which a satellite's trajectory is determined from the original kilometer level to the meter level. In addition, China's first high-precision WDC terrestrial coordinate system has been set up. This research achievement has reached the state-of-the-art.

Dynamic satellite geodesy takes for its main topics of study precision observation methods and motion theory; its main objectives are precise measurement of the earth's form [i.e., size and shape] and gravitational field. Previously only a small number of nations including the U.S., the FRG and France have successfully tackled this key problem. The U.S. Defense Mapping Agency's meridian instrument precision satellite ephemeris and the coordinate measurements based on it are the world standards for a satellite Doppler geodetic system. Over a period of 5 years, Chinese astronomical and measurement scientists and technicians at 14 observatories and artificial satellite observation stations nationwide separately carried out observations of five meridian instrument satellites launched by the U.S.; they acquired [in the process] over 5 million pieces of observational data. In order to join the geodetic coordinates, they traveled across mountains and rivers for over a year, making measurements at nearly 80 points necessary to develop them [into a system] with first-class astronomical geodetic precision.

China's dynamic geodetic satellite research not only solves the problem of accurate determination of satellite orbits for domestic satellite networks, but also solves special problems of determining routes and fixing coordinates in local area networks. The establishment of the high-precision WDC terrestrial coordinate system is a first for China. Moreover, the WDC coordinates and China's astronomical geodetic network are now linked with various world coordinate systems; precision is better than ± 1 meter.

Simple Method for Solving Direct Problems of 3-D Flow in Axial Turbomachinery

40090133a Beijing GONGCHENG REWULI XUEBAO [JOURNAL OF ENGINEERING THERMOPHYSICS]
in Chinese Vol 9 No 3, Aug 88 pp 239-241

[English abstract of article by Zhao Xiaolu [6392 2556 6424] of the Institute
of Engineering Thermophysics, Chinese Academy of Sciences]

[Text] In this paper, the Mean Stream Surface Method (MSSM), employing a Taylor series expansion across the passage of turbomachines, has been developed to solve direct and hybrid problems involving full three-dimensional flow in axial-flow-type subsonic turbomachines. Based on the original indirect procedure, analysis can be made and problems solved using iteration between the S_{2m} flow calculation and MSSM expansion. Two computer programs for analysis and design problems have been developed to meet different conditions. Two examples are given to demonstrate the capabilities of this method.

9717

Stable, Intensified Combustion of Pulverized Coal, CWS Utilizing Multi-Annular Opposing Distributing Jets

40090133b Beijing GONGCHENG REWULI XUEBAO [JOURNAL OF ENGINEERING THERMOPHYSICS] in Chinese Vol 9 No 3, Aug 88 pp 282-284

[English abstract of article by Zhao Huifu [6392 1920 1381], et al., of the Institute of Engineering Thermophysics, Chinese Academy of Sciences; Na Xizhi [6719 1585 1807], et al., of Fuxin Power Plant]

[Text] The stable combustion of low rank pulverized coal and coal water slurry with unpreheated combustion air, as well as industrial precombustion chamber treatment, could be reached utilizing multi-annular opposing distributing jets. The newly-developed technique offers a number of advantages, such as good reliability during operation, excellent flame stabilizing capability and an excellent recirculation zone, of a desirable size, in a large space. The total number of opposing jets is small in comparison with that of the combustion air input, and the jet supply pressure is low.

9717

Experimental Study of Distributions at Exit of Turbojet Afterburner Using Gas Analysis System

40090133c Beijing GONGCHENG REWULI XUEBAO [JOURNAL OF ENGINEERING THERMOPHYSICS] in Chinese Vol 9 No 3, Aug 88 pp 295-298

[English abstract of article by Han Yixiang [7281 2011 3276], et al., of Shenyang Aeroengine Research Institute]

[Text] A new gas analysis system has been established to measure the distributions of fuel air ratio, combustion efficiency and exhaust gas temperature at the afterburner exit in the engine test bench. A number of technical problems, such as simultaneously sampling, automatically collecting and analyzing, have been overcome in this study. It has been proven that the repeatability, reliability and accuracy of the measurements are quite good. This method is effective and can become a very important tool, providing a means to improve the performance of the afterburner.

9717

Structural, Immunological Studies of Lipoprotein From Outer Membrane of
Morganella morganii

40091063a Beijing ZHONGHUA WEISHENGWUXUE HE MIANYIXUE ZAZHI [CHINESE JOURNAL OF MICROBIOLOGY AND IMMUNOLOGY] in Chinese Vol 8 No 3, Jun 88 pp 137-140

[English abstract of article by Huang Yaoxuan [7806 5069 3551], et al., of the Institute of Hepatology, Beijing Army General Hospital]

[Text] The sodium dodecyl sulfate (SDS) extraction method was used to prepare peptidoglycan-linked lipoproteins of Morganella morganii. To determine whether the preparation could stimulate B lymphocytes to secrete immunoglobulin, hemolytic plaque assays were performed with BALB/C mouse spleen cell cultures. Peptidoglycan-linked lipoprotein of M. morganii was shown to be a potent polyclonal activator of immunoglobulin synthesis. The quantitative hemolysis of a SRBC assay showed similar data. Lipoprotein genes from M. morganii have been isolated and cloned into the phage vector λ 569 and the DNA sequence was determined. M. morganii is distantly related to E. coli. Although some differences existed in the DNA sequences, the lipoprotein structure was found to be high conserved except for the carboxyl terminal sequence of seven amino acid residues. The M. morganii lipoproteins are modified with glycerol and palmitic acid and assembled in the outer membrane, as is the case with E. coli lipoprotein. The complete structure of the peptidoglycan-linked lipoprotein of M. morganii is proposed in this paper.

9717

Assay of Beta-Adrenergic Receptors on Mouse Spleen Cells by H-dihydroalprenolol Binding

40091063b Beijing ZHONGHUA WEISHENGWUXUE HE MIANYIXUE ZAZHI [CHINESE JOURNAL OF MICROBIOLOGY AND IMMUNOLOGY] in Chinese Vol 8 No 3, Jun 88 pp 141-145

[English abstract of article by Zhou Jiannian [0719 1696 1628], et al., of the Department of Immunology, Bethune University of Medical Sciences, Changchun, Jilin]

[Text] The Beta-adrenergic receptors on mouse spleen cells were determined by ³H-dihydroalprenolol binding assay. According to the basic principle of receptor binding assays, the authors measured the saturation curve, the kinetics during association and dissociation, and the competition curve, and calculated the B_{max}, K_d value of receptor binding and IC₅₀ of binding inhibition. Mouse spleen cells have been shown to express the Beta-adrenergic receptor clearly, suggesting that the adrenergic transmitter and its receptors on immunologic competent cells may be involved in the immune-neuroendocrine network.

9717

Study of Biotin Labeled Campylobacter Chromosome DNA Probe

40091063c Beijing ZHONGHUA WEISHENGWUXUE HE MIANYIXUE ZAZHI [CHINESE JOURNAL OF MICROBIOLOGY AND IMMUNOLOGY] in Chinese Vol 8 No 3, Jun 88 pp 161-163

[English abstract of article by Zhou Yongtai [0719 0516 1132], et al., of the Institute of Epidemiology and Microbiology, Chinese Academy of Preventive Medicine]

[Text] Photobiotin was applied to label Campylobacter chromosome DNA for yielding biotin-labeled DNA probes. Biotin-labeled Campylobacter chromosome DNA probes were proven specific by the fact that a positive reaction only occurred with the Campylobacter species, and not with E. coli (ETEC, EPEC, EIEC), S. typhimurium or Y. enterocolitica. The specificity was the same as that of ^{32}P -labeled probes. The sensitivity of the biotin-labeled Campylobacter probe (8 ng), when compared with that of the ^{32}P -labeled probe (4 ng), was much lower.

9717

Isolation, Purification, Chemical Analysis of Rough Lipopolysaccharide of Salmonella typhimurium SL 1102

40091063d Beijing ZHONGHUA WEISHENGWUXUE HE MIANYIXUE ZAZHI [CHINESE JOURNAL OF MICROBIOLOGY AND IMMUNOLOGY] in Chinese Vol 8 No 3, Jun 88 pp 164-168

[English abstract of article by Jiao Binghua [3542 3521 5478], et al., of the Endotoxin Laboratory, Department of Microbiology, Second Military Medical University, Shanghai]

[Text] The rough endotoxin, especially the Re endotoxin, is a very important material for studying the structures, biological activities and mechanisms of its interactions with its host. The lipopolysaccharide of Salmonella typhimurium SL 1102 was extracted by a modified phenol/chloroform, petroleum ether (PCP) method from bacterial cells. The authors employed PCP twice, electro dialysis and ultracentrifugation as a series of purification procedures, resulting in a total yield of 2.52 percent (based on the bacterial dry weight). It was free of protein, nucleic acid and glycan. The lipopolysaccharide consisted of glucosamine, 3-deoxy-D-manno-octulosonic acid (KDO), fatty acids and phosphate in a molar ratio of 2:2:6:2. The fatty acids were primarily lauric acid (dodecanoic acid, C₁₂), palmitic acid (hexadecanoic acid, C₁₆) and 3-hydroxymyristic acid (3-hydroxytetradecanoic acid, 3-OH C₁₄) in a molar ratio of 1:1:4. The chemical as well as SDS-polyacrylamide gel electrophoresis analysis of Salmonella typhimurium SL 1102 lipopolysaccharide indicated that this kind of lipopolysaccharide belongs to the typical Re-lipopolysaccharide group. Further experiments involving the preparation of its lipid A component and structural analysis are being studied in the authors' laboratory.

9717

Establishment, Identification of Genus Specific McAb Against Salmonella

40091063e Beijing ZHONGHUA WEISHENGWUXUE HE MIANYIXUE ZAZHI [CHINESE JOURNAL OF MICROBIOLOGY AND IMMUNOLOGY] in Chinese Vol 8 No 3, Jun 88 pp 169-172

[English abstract of article by Zhao Weiguo [6392 5898 0948], et al., of the Institute of Microbiology and Epidemiology, Academy of Military Medical Sciences, Beijing]

[Text] Eight hybridoma cell lines producing McAbs against Salmonella through cell fusion have been established, one of which has been designated as 3A3-1. The results of ELISA show that the McAb 3A3-1 can react strongly with 175 of 181 strains of Salmonella belonging to 40 serogroups and 79 serotypes and covering 96.7 percent of the strains tested. Of these, 110 strains belong to serogroups A-F and show a positive percentage of 98.2, but of the 33 strains of enterobacteriaceae other than Salmonella, 3 strains of E. coli, 1 of proteus and 1 of citrobacter cross-reacted with 3A3-1. Therefore, the authors believe that the 3A3-1 McAb may be a good reagent for detecting Salmonella.

9717

Early T Cells Induced In Vitro to Exert Specific Cytotoxicity to Target Cells

40091063f Beijing ZHONGHUA WEISHENGWUXUE HE MIANYIXUE ZAZHI [CHINESE JOURNAL OF MICROBIOLOGY AND IMMUNOLOGY] in Chinese Vol 8 No 3, Jun 88 pp 173-177

[English abstract of article by Chen Weifeng [7115 1983 1496] of the Department of Immunology, Beijing Medical University; K. Shortman of the Walter and Eliza Hall Institute of Medical Research, Australia]

[Text] Murine early precursor thymocytes, characterized by the phenotype of $\text{Thy-1}^+\text{Ly2}^-\text{L3T4}^-$, have been isolated through either FACS sorting or negative selection by complement-mediated antibody killing. The isolated cells were cultured at limit dilutions in a feeder cell-free single T cell culture system. Under the stimulation of PMA and calcium ionophore, the single early T cell proliferated and differentiated into effector cells in the presence of IL2 and other cytokines. The cytotoxic assay was performed by ^{111}In -release radioautography, and the positive CTL clones were scored as dark spots on X-ray films. Among early T cells, the frequency of alloreactive ($\text{H-2}^{\text{Kd}}\text{H-2d}$) cytotoxic T cell precursors (CTL-p) was 0.0099 ± 0.0021 , while the frequency of total CTL-p (scored by PHA-mediated toxicity) was 0.0158 ± 0.0018 , so that the alloreactive CTL-p constituted 63 percent of the total CTL-p. In parallel experiments involving cortisone-resistant thymocytes (CRT), the frequency of alloreactive CTL-p was 0.016 ± 0.007 , while the frequency of total CTL-p was 0.130 ± 0.007 and, therefore, the alloreactive CTL-p constituted 12.3 percent of the total CTL-p. These results imply that the alloreactive CTL-p develop earlier in the CTL process. Considering the fact that NK cells could not be excluded in the authors' experiments, the actual number of antigen-specific responsive CTL-p was at least one-third of the total CTL-p.

After culturing in vitro, the phenotypic maturation of early T cells was manifested by the expression of Ly2 or L3T4 antigens. The early T cells gave rise to three subsets of thymocytes bearing $\text{Ly2}^+\text{L3T4}^+$; $\text{Ly2}^+\text{L3T4}^-$; and $\text{Ly2}^-\text{L3T4}^+$ phenotypes.

9717

Chronic Asymptomatic Hepatitis B Virus Infection, Reactivity of Tuberculin Skin Test

40091063g Beijing ZHONGHUA WEISHENGWUXUE HE MIANYIXUE ZAZHI [CHINESE JOURNAL OF MICROBIOLOGY AND IMMUNOLOGY] in Chinese Vol 8 No 3, Jun 88 pp 178-180

[English abstract of article by Luo Kangxian [7482 2123 0341], et al., of Nanfang Hospital, First Military Medical University, Guangzhou; Zhu Huaqiang [2612 5478 1730] of Luojiadu Miner Hospital, Lechang, Guangdong]

[Text] In individuals with chronic asymptomatic HBV infection, serologic HBV investigations and tuberculin skin tests were performed simultaneously. In tuberculin tests showing positive and negative results, the prevalence of HBeAg was 42.4 percent and 28.6 percent, respectively, while that of elevated serum alanine aminotransferase was 8.7 and 3.4 percent. Both differences were significant. The results showed that tuberculosis infection might suppress the replication of the hepatitis B virus, thereby alleviating the inflammatory response in the liver. BCG vaccination might have the same effect.

9717

Isolation, Bioactivity Assay of Plasma Non-Specific Immunosuppressive Proteins of Pigs (PNIP)

40091063h Beijing ZHONGHUA WEISHENGWUXUE HE MIANYIXUE ZAZHI [CHINESE JOURNAL OF MICROBIOLOGY AND IMMUNOLOGY] in Chinese Vol 8 No 3, Jun 88 pp 181-184

[English abstract of article by Geng Yongjian [5105 3057 1696], et al., of the Department of Pathophysiology, Suzhou Medical College]

[Text] A protein fraction, designated as plasma non-specific immunosuppressive protein (PNIP), was isolated from the blood of pigs with a DEAE-cellulose chromatography column. PNIP could inhibit the mitogenic reaction to PHA or Con A of human peripheral blood lymphocytes or C57Bl/6J mouse spleen lymphocytes. The inhibition of PNIP-treated lymphocytes was higher during the early stage of mitogenic reaction when PNIP was added to the culture. PNIP also suppressed the proliferation and ^3H -TdR incorporation of malignant lymphoma cells, L5178Y and Raji cells. The inhibitory proteins in PNIP had molecular weights of approximately 60000 or 70000 and different heat stabilities. The large molecular proteins of PNIP might link to the low molecular weight inhibitory fractions noncovalently to produce inhibitory activity.

9717

Studies of Biological Properties of Chemical Vaccine Prepared From Antigenic Fractions of Vibrio cholerae

40091063i Beijing ZHONGHUA WEISHENGWUXUE HE MIANYIXUE ZAZHI [CHINESE JOURNAL OF MICROBIOLOGY AND IMMUNOLOGY] in Chinese Vol 8 No 3, Jun 88 pp 188-192

[English abstract of article by Zheng Zhenxi [6774 6966 6007], et al., of Chengdu Institute of Biological Products]

[Text] As stated in a previous paper, the chemical vaccine was prepared by mixing equal amounts of the antigenic fractions I, II and IV. Animal experiments revealed that the vaccine could induce close to the same or even a higher degree of immunity than the whole cell vaccine or the whole cell + toxoid vaccine with high titers of vibriocidal power, agglutinin and neutralizing antibody. A remarkable increase in IgG content occurred in the serum of immunized animals, as did an enhancement of intestinal colonization. The maximum amount of LD₅₀ tolerable in mice was greater than 71.947. The authors conclude that this vaccine is a promising candidate for use in human immunization.

9717

Quick Propagation of Pathogenic Salmonella Bacteria

40081090a Beijing WEISHENGWUXUE TONGBAO [MICROBIOLOGY] in Chinese Vol 15
No 3, Jun 88 pp 117-120

[Article by Xing Nianyi [6717 1819 5030] and Li Haixia [2621 3189 7029]
of the Research Institute of Military Medicine, Jinan [3444 0589] Military
Region, Jinan.]

[Summary] Due to the increasing number of cases of typhoid fever, pediatric dysentery, and food poisoning caused by Salmonella typhosa and S. typhimurium, techniques to speed up bacterial culture and to shorten its culture time have been developed to quickly diagnose the disease. The improved salmonella cultural medium does increase the propagation 1.43-3.97 times greater than the traditional O2 quick bacteria propagation method.

The pathogens cultured and tested are:

Salmonella typhosa 50096
S. Typhimurium S-155
S. paratyphi A 50001
S. paratyphi B 50007
S. Cho-Lerae-Suis 491
S. newington 50049

Other normal bacteria cultured are:

E. coli
Staphylococcus aureus

The improved medium is especially appropriate for promoting growth of S. typhosa 50096 and S. typhimurium S-155. Their propagation rates are 3.97 and 3.7 times greater than the O2 method, respectively. Also the improved medium has less effect to S. newington 50049 and s. paratyphi B 50007 (about one time greater than that of O2 method), and has no effect on S. paratyphi A 50001 and S. Cho-Lerae-Suis 491 at all. Since the new improved medium inhibits growth of E. coli and Staphylococcus aureus, if the timing is right, it is easier to produce a larger quantity of purer S. typhosa and S. typhimurium in the new medium because of its advantages to the two pathogenic bacteria.

/9604

Studies on Tick-Borne Encephalitis Virus Genome RNA Isolation and Property

40081090b Beijing WEISHENGWUXUE TONGBAO [MICROBIOLOGY] in Chinese Vol 15
No 3, Jun 88 pp 109-111

[Article by Yang Peiying [2799 0160 5391], Si Bingyin [0674 3521 6892],
and Huang Zhi [7806 1807 1424] of the Research Institute of Microbial
Epidemiology of the Academy of Military Sciences, Beijing.]

[Summary] The extraction of tick-borne encephalitis virus RNA genome
directly from a rat's brain tissue instead of culturing the virus-infected
tissues in the medium is described. The total viral RNA and cell RNA were
then separated by sepharose 4B column chromatography. Typical uv absorption
spectrum of the recovered viral RNA is 260 nm, the ratio of 260/280 is 2;
it is also sensitive to RNase enzyme and is pathogenic.

The traditional ways of extracting encephalitis viral RNA are: Culture
the infected tissue in a suitable medium, then condense the medium,
purify the viral particle and extract the ribonucleic acid. Because the
titer of the rat's brain infection by tick-borne encephalitis virus 10
pfu/ml is 2-3 titers higher than the tissue culture, it is much more
efficient to directly extract the total RNA (viral RNA + cellular RNA)
from infected rat brain tissue than from the culture medium. The direct
extracting method is easy, fast and is valuable for extensive application.

/9604

BRIEFS

Third Generation Snake Toxin Preparation--A low toxicity, high efficacy third generation anti-thrombosis snake toxin (anti-thrombus enzyme-3) has been developed and manufactured by the Shanghai Research Institute of Biochemistry of the Chinese Academy of Sciences in collaboration with the Chinese Medical University. The toxicity of this new preparation is 1/8 of the first and second generation toxins; the efficacy rate is promoted to 96.9 percent from 70 percent and 90 percent of the two previous generations and is clinically more effective than the traditional anti-coagulant--low molecular dextran. So far, two kinds of preparations are using for clinical treatments, injection vials and oral pills. [Summary] [40081091a Beijing RENMIN RIBAO in Chinese 12 Jul 88 p 3] /9604

Gene Engineering Human Growth Hormone--A gene reconstructed human growth hormone is being manufactured by the researchers in Shanghai Research Institute of Cell Biology of the Chinese Academy of Sciences. The product can be used to treat dwarfism due to growth hormone deficiency, and burns, fractures, hemorrhagic ulcers, Tinel's sign, tissue necrosis, muscular dystrophy, osteoporosis, adiposis obesity, etc. Its physical and chemical properties such as purity, molecular weight, isoelectric point, and uv absorption spectrum, resemble those of natural human growth hormones. The 95 percent and higher-purity extract allows the preparation's clinical application and being put into large quantity commercialized production. [Summary] [40081091b Beijing RENMIN RIBAO in Chinese 15 Jul 88 p 3] /9604

Producing Root Nodules in Non-Legume Plants--Associate Professor of the Research Institute of Microbiology in Shandong University has succeeded in inducing root nodule formation in such non-legume plant as wheat plant by treating the root systems with 2,4-D plant growth hormone before introducing nitrogen-fixation bacteria (root nodule bacteria) into the nodule cells. The implanted bacteria-containing areas of the artificially induced root nodules do show stable nitrogen-fixation activities. [Summary] [40081091c Beijing GUANGMING RIBAO [GUANGMING DAILY] in Chinese 20 Jun 88 p 1] /9604

Super Low-Temperature Pollen Preservation--One of the Seventh-Five Year Plan's key projects, 'Study on Super Low-Temperature Corn Pollen Preservation' carried out by the Research Institute of Crop Germplasm Resource of the Chinese Academy of Agricultural Sciences, is said to be a success. Tests proved that the 1-year preserved pollen under temperatures as low as -196 C showed no change in basic metabolic activities and genetic variations, and its life was greatly prolonged. The key techniques of corn pollen preservation developed by the researchers are: 1) Pollen pre-treatment techniques before freezing. 2) Techniques of freezing and thawing. 3) Techniques of measuring pollen metabolic activities. 4) Techniques to clearly study the relationship between pollen water-content and the effectiveness of preservation. So far, only such living materials as red blood cells, lymphocytes, bone marrow, skin, semen, and embryos have been successfully preserved; the techniques of preserving plant specimen are still under study. [Summary] [40081091d Beijing BEIJING KEJI BAO [BEIJING SCIENCE AND TECHNOLOGY NEWS] in Chinese 7 May 88 p 2] /9604

Memory Hierarchical Structure in the AI Computer LISP-M1

40090129a Xi'an XI'AN JIAOTONG DAXUE XUEBAO [JOURNAL OF XI'AN JIAOTONG UNIVERSITY] in Chinese Vol 22 No 3, Jun 88 pp 9-14, 8

[English abstract of article by Shan Degen [0830 1795 2704] et al., Department of Computer Science and Engineering]

[Text] A memory hierarchical structure in the LM-LP-HS (list memory-list processor-hard stack) interconnection which is better than the CPU-CACHE-MM architecture is presented. It improves the execution efficiency of the AI language LISP. Prefetching and updating strategy are taken in accessing list memory, transforming the linear memory space into the binary tree memory space in order to satisfy the requirements of the LISP interpretation system. Also described are the design scheme, organization and interface of the list memory. (Received 10 March 1988)

/12232

Design and Implementation of a List Processor in LISP Machine LISP-M1

40090129b Xi'an XI'AN JIAOTONG DAXUE XUEBAO [JOURNAL OF XI'AN JIAOTONG UNIVERSITY] in Chinese Vol 22 No 3, Jun 88 pp 15-21

[English abstract of article by Qian Depei [6929 1795 3099] et al.,
(Department of Computer Science and Engineering)]

[Text] The architecture of a list processor LP in the LISP machine LISP-M1 is presented. Working as a back-end processor attached to a host machine, LP uses microprograms to interpret directly an intermediate code generated by the host. The semantics of the intermediate code are very close to LISP, so that the semantics gap between the LP machine language and LISP is narrowed. LP contains special hardware such as a data assembly register and data field extracting and matching circuits, for efficient dynamic data type checking and data tagging, which reduces the run-time overhead. A large high-speed hardware stack is used to support deeply nested calling and the recursive evaluation process. Several design considerations and implementation techniques are also illustrated. (Received 10 March 1988)

/12232

Compact List Representation and Its Implementation on LISP Machine LISP-M1

40090129c Xi'an XI'AN JIAOTONG DAXUE XUEBAO [JOURNAL OF XI'AN JIAOTONG UNIVERSITY] in Chinese Vol 22 No 3, Jun 88 pp 23-30

[English abstract of article by Zhao Yinliang [6392 6892 0081] et al.,
(Department of Computer Science and Engineering)]

[Text] A scheme of compact list representation on the LISP machine LISP-M1 is supported. Its advantages, compared with other LISP machines, are as follows: use of the 2-bit CDR-coding field containing the code used for list representation and the code used for garbage collection, satisfactory hardware support, fewer objects being copied in garbage collection, and elimination of the unused I-cell by this copy algorithm. The completeness and efficiency of this scheme are discussed, and the list processing and garbage collection algorithm is given. It is indicated that this scheme is feasible and efficient after implementation of the LISP-M1 system. (Received 10 March 1988)

/12232

Investigation of Implementation of Evaluator on LISP Machine LISP-M1

40090129d Xi'an XI'AN JIAOTONG DAXUE XUEBAO [JOURNAL OF XI'AN JIAOTONG UNIVERSITY] in Chinese Vol 22 No 3, Jun 88 pp 31-36, 22

[English abstract of article by Dai Donglai [2071 2639 0171] et al.,
(Department of Computer Science and Engineering)]

[Text] The evaluator based on a subset of COMMON LISP, on the LISP machine LISP-M1 is discussed. A new approach to data representation is proposed, namely, a mixed method using tagged objects on the whole and typed pointers wherever suitable. In procedures of dynamic type checking, various function calling, list memory accessing, and so forth, proper microprogramming strategies are adopted to improve efficiency. Results of running the evaluator on the simulator of LISP-M1 show that it does boost the performance of LISP programs. (Received 10 March 1988)

/12232

Status, Future Prospects for CAD

40080185 Beijing JISUANJI SHIJIE [CHINA COMPUTERWORLD] in Chinese No 25,
29 Jun 88 pp 18-19

[Article by Fang Jiaqi [2455 1367 7496], North China Institute of Computing:
"Status and Future Prospects for CAD in China"]

[Excerpts] The Status of CAD Development and Application in China

Electronics CAD

Electronics CAD was the earliest field of application for CAD technology in China. At present, the main development and applications efforts are concentrated on design and manufacture in three areas: printed circuit boards, computers, and integrated circuits. These software systems all include components for logic simulation, automatic placement and wiring, test code generation, inspection of design rules, and mask pattern generation, and the scale has reached the ability to handle source code in the tens of thousands of lines. Although all components are usable, there is still a gap when compared to commercial products and to foreign software of the same type. One important factor is the weakness of the Chinese electronics industry, which has yet to reach economies of scale (apart from individual products) and lacks a vital need for electronics CAD products. In contrast, there is still a demand for low-grade, PC-based printed circuit board CAD systems.

Machinery CAD

Machinery CAD in China has recently made great strides in step with the growth of foreign machinery CAD technology. It has exceeded electronics CAD in both development and applications aspects, and the PC-based machinery CAD has been particularly rapid. The majority of mainframe CAD systems in this area are currently imported, and they are invariably one component of the technology transformation items for a large industry. After a period of absorption and secondary development, they have now begun to be used in depth. These systems are all concentrated in key aeronautics, shipbuilding, and vehicles enterprises. The primary problem for these systems has been the great amount of investment needed, which is not easy to recover since there is no way to disseminate this domestically. And at the same time, some institutions and colleges in China have been developing some machinery

CAD software that include two- and three-dimensional interactive plotting, geometric modeling, finite element analysis, physical calculations, and numerically controlled paper tape generation. In addition, they have also developed some CAD software that is geared to pattern design and to aircraft, ship, and vehicle design. This software is largely for microcomputers and superminis, but one segment has been transplanted to engineering workstations. The functions and performance of this software are still uneven, but all have been commercialized and have made a start at being competitive. The primary current problems have to do with the limitations of microcomputers themselves, and also of the manpower in the development units. These software programs are invariably incomplete, cannot satisfy the project demands, and are still limited in terms of economic results.

Construction Engineering (AEC)

With the development of China's construction industry and the introduction of competitive mechanisms, the application of CAD technology in construction engineering is now receiving much attention. Under the unified deployment of the Design Bureau of the State Planning Commission, all major design institutes throughout the country have begun import and development efforts for CAD systems. One of the more significant import items among these is the group of systems based upon the Apollo workstations. As compared to the electronics and machinery industries, there is a greater amount of secondary development work with imported AEC systems because there is a greater distance between the standards and norms used by China's construction industry and those abroad.

As far as software development is concerned, the majority of machinery CAD software can be used for construction engineering with little or no modification, as for example with two- and three-dimensional interactive plotting, geometric modeling, and finite element analysis. Apart from that, all domestic units have developed some CAD software primarily for use in construction engineering, among which functions are high-level construction design, pipeline design, highway bridge design, and construction reinforcement charts. This software is also all done for microcomputers and superminicomputers. Because there are significant results from construction engineering design and investment is quickly recovered, the economic results for this kind of software are better than for the electronics and machinery industries as there is greater market potential.

CAD Hardware and Support Software

CAD is a computer applications field, and the host computer can be any scale of CPU. Apart from requirements for high-speed floating point operations and large quantities of RAM, there are no other particular demands. The primary difference between these and general purpose computers is in the peripherals. To input and output graphics information, they must be fitted with interactive graphics terminals, plotters, digitized instruments, graphics input boards, and mice. Aside from particular low-grade models, this graphics equipment has for the most part not been Chinese-made. We

must currently rely completely upon imports for those popular new foreign engineering workstations that tightly integrate the host computer with the graphics display.

As far as graphics support software is concerned, over the past 2 years, the North China Institute of Computing, the East China Institute of Computing and the Office of Automation of the Chinese Academy of Sciences have jointly developed the GKS Graphics Kernel System for use on superminis and PC's. This software has provided a standard graphics program design tool for the development of CAD software, and has improved the portability of CAD software. The GKS software developed by the North China Institute of Computing supports various graphics equipment on the Taiji 2220 computer, and has passed strict testing according to international standards. Some of this software has begun to be commercialized. Also, some colleges and institutes within China have done quite a bit of work on three-dimensional true-sense graphics and engineering databases.

In summary, CAD in China is still undergoing much research, but little application. Research efforts are at a high level, but utility and commercial programs are lower, while economic results are not high and applications are too narrowly applied.

Some Suggestions for Developing CAD in China

1. To develop China's CAD industry, we must make the production of micro-computer workstations and engineering workstations Chinese.

China's microcomputer industry has achieved a significant foundation, and the use of microcomputers has become widespread. If microcomputer costs could be lower, which would suit the fact that China's industries have insufficient capital, this would aid their dissemination. This is the main point for making their production Chinese. The key to converting an ordinary PC into a workstation is the addition of high resolution graphics. To fully utilize the new generation of graphics processing chips, we must develop our own graphics controller boards and graphics support software. To then add existing and newly developed CAD applications software, this would then create a microcomputer CAD system of low cost, powerful performance, and one that is in keeping with the Chinese national situation. When you realize that some mainframes and high level CAD systems still need high performance engineering workstations, then these, too, should gradually be made Chinese. Since these workstations are mostly based upon high performance microcomputers or miniaturized minicomputers, making these into Chinese products should be easier than with the mainframe and superminis. The primary difficulty in making these products Chinese is that computer technology has developed too quickly abroad, and the pace of our nationalization efforts cannot keep up with the pace of foreign development. This easily leads to the phenomenon whereby "we have yet to copy something that has already become obsolete!"

2. We should strongly encourage the development and commercialization of CAD software.

Because there is relative independence and stability between software and hardware, in contrast to hardware, we will not easily experience the phenomenon of obsolescence. To resolve the difficulties whereby our software personnel are dispersed and therefore it is difficult to concentrate this strength with the existing system, as well as to guard against developed software being rejected because of mistakes in selecting types of computers or too much time having passed, we should first establish a standard CAD software development environment to achieve Chinese production of support software. To as great an extent as possible, the standards of this environment should be the same as those popular abroad, to which would be added corresponding Chinese character functions. We should also formulate those corresponding Chinese character standards.

Another problem with software development is to set up a software commercialization environment as quickly as possible, and this would include software copyright protection and software pricing standards. We should establish channels of circulation for software products and preferential policies regarding financing and taxation. Only in this way can we eventually turn around the inefficient situation whereby China's CAD software "has a great deal of research, few applications, poor economic results, and a narrow scope of application."

3. China's CAD development should actively take part in the greater international scene, and should make use of two resources to target two markets.

First, as China's coastal region has opened up, even more enterprises will begin to compete in international markets. To succeed in international competition, they will require technology to make this possible for CAD. This would provide for CAD products a broad domestic market and resolve the current problem whereby demand for domestic CAD products is quite weak. Second, CAD is a technology-intensive high tech product, and it has a value in international markets that is several times that of the domestic. As the coastal region develops, conditions will be created for China's CAD products to enter the international marketplace. Naturally, if we do not change our concepts and organization, it will be very hard to make a place for ourselves in the highly competitive international marketplace. But on the other hand, if we do a good job of this, we can not only reap good economic results, but will also greatly promote the creation of a Chinese CAD industry, improvement of its level of technology, and the dissemination of CAD applications.

12586/6091

Software System for Digital Processing of Clouded Images

40080011c Beijing JISUANJI SHIJIE [CHINA COMPUTERWORLD] in Chinese No 29,
27 Jul 88 p 17

["National Defense University of Science & Technology Develops Generalized Software System for Digital Processing of Clouded Images"]

[Text] A generalized software system employing a novel technique for digital processing of clouded images has been developed by the Space Technology Department of the National Defense University of Science & Technology (NDUST), and recently underwent technical certification. This method for measuring various deformations in cloudy textures [yun wen 0061 4773] makes use of the principle of geometric interference generating cloudy striations [tiao wen 2742 4773]. Since the method is uncomplicated, can be used to measure a wide range of deformations, and has the prominent feature of being suitable for use at actual worksites, it has wide applications in aeronautics, machinery design and manufacture, and engineering projects such as properties of metallic and non-metallic materials.

The hardware configuration for NDUST's generalized software system for digital images of cloudy textures includes an IBM-PC/XT microcomputer, a plotting instrument, a image frame-grab device, and other units. The image sampling matrix is 512 x 512, with 256 gray levels; sampling rate is 30 frames per second. The system not only performs ordinary tasks of digitized processing of cloudy images, but also displays over ten new modes not yet seen in the world--rotary filtering [xuan lubo fa 2467 3459 3134 3127], linear enhancement of partitions [fenqu xianxing zengqiang fa 0433 0575 4848 1840 1073 1730 3127], a [new] center-line method of using the second-value derivative chart of the cloudy texture to extract full-field striation data, a multiplication technique for cloudy striations, etc.--which represent a breakthrough from the traditional center-line extraction technique for processing and which permit full-field transformation processing of cloudy charts and direct plotting of full-field quantitative visible results. This greatly improves computing speed and accuracy and achieves results not obtainable by several traditional methods. Trial use at the Hefei Universal Machinery Institute has demonstrated that its processing speed is several hundred times faster than that of traditional methods.

Observers at the accreditation agreed that the techniques utilized in this achievement manifest originality, simplicity and practicality, and are of a quite high level [of expertise]. They felt that the high-performance, fast-running, easy-to-use system software has broad value for engineering applications and recommend that its utilization be popularized as quickly as possible.

BRIEFS

CAS Acoustics Institute's Signal Processors--Six TMS320-series multifunctional development/high-speed signal processing systems recently perfected by Laboratory 10 of the CAS Institute of Acoustics underwent accreditation on 25 May. The series, already in use at 200 institutions nationwide, is based on Texas Instruments' TMS320 series, and includes the TMS32010B; the TMS32020A, B, and C; and the TMS320C25A and B, as well as corresponding development software. The systems utilize a modular structure, with a variety of plug-in cards and software packages that can be changed to suit the user's needs, and can carry out TMS320-series software and hardware development. They come with two selection modes for data acquisition and provide high-speed computations for digital signal processing functions such as FFT, IFFT, autocorrelation, power spectrum, cepstrum, cross correlation, cross spectrum, convolution, convolution spectrum, etc. They are also applicable to real-time simulation of signal processing programs and algorithms. [Summary] [40080186a Beijing JISUANJI SHIJIE [CHINA COMPUTERWORLD] in Chinese No 24, 22 Jun 88 p 13] /12232

Digital Signal Processing Board--The KL-GIEB(1) digital signal processing board, recently jointly developed by Keli [4430 3810] High-Technology Company and Qinghua University for three-dimensional graphics, images, and general purposes, uses the most advanced components and has a dual-bus parallel processing/parallel pipelined structure suitable for high-volume, complex computations. It can raise the speed of PC/AT, XT and compatible computers by 2000 times to that of a minicomputer, and thereby provides functions originally difficult for a microcomputer, such as two-dimensional FFT, three-dimensional graphics transforms, etc. It consists of a PC VISION image input board and an AGC or KL-GCB graphics control board. Image processing speed is comparable to that of the VAX 11/750 + MODOL75 system, and three-dimensional graphics processing speed is comparable to that of a low-grade workstation. The KL-GIEB(1) uses two TMS320C25 CPUs [Texas Instruments], with an instruction cycle of 100 ns, and has a 20K high-speed dual-port RAM and a 16K local RAM. [Summary] [40080186b Beijing JISUANJI SHIJIE [CHINA COMPUTERWORLD] in Chinese No 25, 29 Jun 88 p 12] /12232

Large-Screen Plasma Display System--The world's first large-screen plasma display system has been developed by the Chinese Air Force Institute 3 (Communications Research). This system can display electronic text, graphics, industrial ads, and sports information, and can be put on line with various computers. It uses Hangzhou University's multipanel, flat-screen 5-sq-m ac display apparatus, which has a 640 x 510 pixel array, a resolution of 256 lines per character, line-by-line grating scanning, and a 75 Hz picture

frequency. The full screen can display 1000 Chinese characters, each in the national-standard 15 X 16 dot matrix format. This system, characterized by high brilliance and contrast, wide-angle viewing, and low power consumption (less than 1000 volt amperes), consists of a single-board computer, a DMA control circuit board, a character base, a timing system, row- and column-drive circuit boards, a high-voltage pulse drive power supply, the screen, and other components. The screen, in turn, consists of [100] units, each 250 mm x 200 mm, made up of two parallel 5-mm-thick glass plates, spaced 200 microns apart, which form an air-tight enclosure filled with the plasma. Each plate has on its inner surface a transparent conductive layer formed from a series of parallel strips--in the X direction for one plate and in the Y direction for the other. The points where the lines cross become dots in the array. When the X and Y electrodes are excited by ac signals, they cause the plasma to ionize and recombine; each excitation is therefore followed by an optical glow. [Summary] [40080186c Beijing RENMIN RIBAO [PEOPLE'S DAILY (Overseas Edition) in Chinese 27 Jul 88 p 1, Beijing JISUANJI SHIJIE [CHINA COMPUTERWORLD] in Chinese No 25, 29 Jun 88 p 13] /12232

Multiple-Font Character Recognition System--China's first practical multiple-font-character document recognition system, recently developed by the PLA's Electronic Technology Institute, passed provincial-level certification on 7 June in Zhengzhou. Consisting of a Ricoh IS30 page-style image scanner (300 dpi resolution), a 386-series microcomputer, and a Cordata lp300x laser printer, the system was tested with a number of official party, political, and military documents set in a mix of No 3 imitation-Song-dynasty and No 3 boldface typefaces; recognition rate was 97.4-99.5 percent, with an average recognition speed of 2.6 characters per second. Results can be stored, edited, typeset, or printed out, as desired. [Summary] [40080186d Beijing JISUANJI SHIJIE [CHINA COMPUTERWORLD] in Chinese No 26, 6 Jul 88 p 1] /12232

Sino-American Joint Venture--Tianjin's Zhonghuan Computer Company and the U.S. company CST (Computer Systems Technology) are making arrangements to set up a joint venture to be named Zhonghuan Systems Equipment Ltd. The feasibility proposal for this project was approved in the past few days at Tianjin. Talks between the two parties have entered the substantive planning phase. The joint venture will be set up in the Tianjin computer industrial zone; its products will include superminicomputers and 32-bit workstations, [auxiliary] parts (including power supplies and cases), peripheral systems, and appropriate applications systems. Investment for the joint venture will total US\$3 million, with one-half of the products to be sold on the foreign market. [Text] [40080186e Beijing JISUANJI SHIJIE [CHINA COMPUTERWORLD] in Chinese No 26, 6 Jul 88 p 1] /12232

Japanese Software Firm Formed in Beijing--The Taiyo-ASCII Company, a software firm which is the first such venture in China without Chinese participation, is now soliciting customers in Beijing. Capitalized at 500 million yen (80 percent from Taiyo, 20 percent from ASCII), the firm expects sales of around 300 million yen for the first year. Taiyo-ASCII will concentrate on software packages initially, later expanding to handle local area networks and information systems. [Summary] [40080011a Beijing JISUANJI SHIJIE [CHINA COMPUTERWORLD] in Chinese No 29, 27 Jul 88 p 1]

New Computer Institute Formed--A new high-technology firm, the Beijing Zhongruan [0022 6516] Computer Research Institute, was established a few days ago. Its area of emphasis will be in developing new high-tech products for signal processing and industrial process control while simultaneously opening up new domestic and foreign markets, new scientific research channels integrating technology, industry, and trade. Products to be developed include high-speed 32-bit signal processor development systems (ATD320 series); industrial control systems (8096/8051); and practical instruments, universal software packages, and special-purpose digital systems and equipment for biology and medicine, voice and acoustic communications, image processing, and high-speed robot control. [Text] [40080011b Beijing JISUANJI SHIJIE [CHINA COMPUTERWORLD] in Chinese No 29, 27 Jul 88 p 1]

Defense Data Processing System--A data processing system to serve administrative and technical personnel in the Ministry of National Defense and in the defense industry has recently been developed in Beijing. This is the first domestic large-scale on-line numerical Chinese-character data retrieval system for national defense. At today's accreditation ceremony attended by almost 40 officials from the Commission of Science, Technology and Industry for National Defense, from the Chinese Academy of Sciences, from the State Science and Technology Commission and elsewhere, specialists unanimously agreed that this system, designed by the National Defense Science & Technology Information Center, will provide an excellent foundation for establishing a data network for and realizing administrative automation in defense science, technology and industry. All critical data and important targets from research institutes in the Ministry of National Defense and from industrial enterprises will be entered into the system. [Summary] [40080005a Beijing RENMIN RIBAO in Chinese 4 Aug 88 p 3]

Recent Developments in Flexible Manufacturing Systems, Robotics

FMS Simulation System

40080177 Beijing JISUANJI SHIJIE [CHINA COMPUTERWORLD] in Chinese 8 Jun 88 p 2

[Text] The "ESIM/FMS Flexible Manufacturing System Simulation System" undertaken by the East China Engineering Institute has undergone more than 2 years of research and development, and not long ago passed technical evaluations by the State Commission on Machine Building.

The "ESIM/FMS Flexible Manufacturing System Simulation System" is comprised of both hardware (IBM PC/XT microcomputer, high-resolution color graphics monitor, and peripherals) and software systems. The software systems include five software packages: 1) a queued network model simulation software package; 2) a statistical model simulation software package; 3) an ACD model simulation software package; 4) an animated simulation package for tool flow; 5) the FMS manufacturing database, which extensively covers simulation matters from the preliminary design to the detailed design stage of flexible manufacturing systems for prismatic components. By use of the simulation software such as the queued network model, statistics model, and the ACD model to design flexible manufacturing systems and evaluate performance indexes, one can provide a valuable basis for decisionmaking for those activities, and it is suitable for use in both the preliminary and detailed design stages for flexible manufacturing systems. The FMS animated simulation software comprehensive analysis of tool flow and job flow integrates such matters of simulated analysis as FMS job flow, tool flow, and control with dispatch strategies and an animated display. With this, one can do FMS surface topological design, detailed analysis of each performance index in a system, and the entire process of job and tool flow behavior throughout the system can be displayed in animation.

The successful development of the "ESIM/FMS Flexible Manufacturing System Simulation System" has brought China powerful means of analysis for the highly efficient, flexible operations of FMS that have already been imported, and it will in addition provide a complete set of quantitative designs tools as we design our own FMS.

Experts of the evaluation committee unanimously agreed that the animated simulation software that can comprehensively analyze job flow and tool flow

comes with simulation software that is of high quality. They said its design is rational, its methods advanced, the software structure is modular, and that the operation was accurate and reliable. The entire "ESIM/FMS Flexible Manufacturing System Simulation System" has a complete set of features, has reliable performance, the hardware configuration is economical and reasonable, and the software is easily maintained. This is an FMS simulation system that meets contemporary advanced international standards.

Largest Domestic FMS Passes Test

40080177 Beijing ZHONGGUO JIXIE BAO in Chinese 16 Jun 88 p 1

[Article by Liang Yanfu [2733 1693 1788]: "China's Largest Flexible Manufacturing System Passes Acceptance Tests"]

[Text] China's largest Flexible Manufacturing System, a key state project in the Sixth and Seventh 5-Year Plans, underwent Chinese and foreign acceptance tests in late May at the Zhengzhou city Textile Machinery Plant. This computer-controlled, multifunctional, highly automated manufacturing system has broad applications in machining of product components. The system's cutting base has a memory for handling 96 cutting tools. In one pallet cycle, the machining center can simultaneously carry out operations (such as milling, drilling, boring, enlarging, grinding and polishing, and tapping) on five surfaces of the components. Processing of one lap wallboard [or "wall plate"] that previously required 15 days can now be completed in 2 hours. The system was jointly developed over the past 4 years by Zhengzhou Textile Machinery Research Institute and the FRG's Hannover University. By the end of the acceptance tests, the system had been in normal operation for over 2 months.

Beijing Robotics Research

40080177 Beijing JISUANJI SHIJIE [CHINA COMPUTERWORLD] in Chinese 22 Jun 88 p 16

[Article by Ze Honglin [3419 4767 3829]: "Beijing Robotics Research and Examples of Applications"; first paragraph is JISUANJI SHIJIE introduction]

[Text] Robotics is a hot subject in the field of computer applications both in China and in other countries. The core of robotics is computer technology, and it makes use of the capacity for intelligence, memory, and rapid operations of the computer to direct and control an executing structure according to a particular program to accomplish the necessary motions. Robots can work at tasks that are precise and dangerous, and monotonous and highly repetitious, which means a broad range of application areas. China has achieved a significant level and scale in robotics research and applications, so in order to promote further research and application of this hot topic in computer applications, we are here publishing news we have gathered about robotics research and applications by some units in the Beijing area to share with our readers.

I. A Painting Robot

1. Because of the adverse conditions of painting and its high degree of labor intensity, the Offices of Automation of the former Ministry of Labor and Personnel and the Ministry of the Machine Building Industry began to develop a painting robot in 1981. By the end of 1985 they had finished a sample of the model PJ-1 robot, and in 1986 it began to be used on the chassis painting line of the Beijing Jeep Vehicle Company, Ltd. This domestically designed and produced multiply articulated microcomputer controlled painting robot is controlled by the DJK-200 (S-09) 8-bit microprocessor. It has yet to fail after more than a year of field operations, the quality of painting has improved, and it allows workers to avoid the hazards of paint pollution, for which it has been welcomed by them. This company has decided to add another robot, which is currently undergoing installation and debugging.

2. With the help of the Beijing New Technology Applications Institute, the Television Assembly Plant No 1 in Beijing Municipality imported a Japanese Tokiko Armstar RCM806R painting robot in 1986. This machine learns through CP and PTP, its wrist portion can hold 5 kg, its maximum speed is 2,000 mm/s, it has repeated precision of -2 mm, each disk will hold 140 programs, and its maximum time for retention is 87 minutes. After 6 months operation, statistical results showed an increase in profits of 60,800 yuan, that 90-96 percent one-coat paintings were satisfactory (74 percent when by hand), and that the totals for new output value profits and savings of material expenditures were 224,800 yuan. Certain other indirect results were also realized, as for example the good showing for economic results that year and a great increase in enthusiasm for applications by research personnel and factory staffs.

II. A Welding Robot

The horizontal jack manufactured by the Beijing Vehicle Jack Plant No 2 is a product that generates foreign exchange, and it has always been manually welded. In 1986 they installed two MOTOMAN-LIOW independent welding robots they had imported from Japan. With the aid of the Electromechanical Academy of Beijing, this plant undertook technological transformation in the field, they test-produced a coordinated set of project clamps, and undertook electromechanical coordinated dispatching and teaching operations. Since testing began, these robots have greatly reduced labor intensity for the workers, they have protected the health of the operators, and there have been significant improvements in both quantity and quality of production. According to preliminary calculations, there can be an annual realization of 427,500 yuan in profit in the areas of energy conservation, conservation of materials, improvements in quality, and increases in production. When foreign business interests had seen the product and that the processing procedure used robots, they rushed to place orders, and those orders for 1988 have been abruptly strengthened from the 200,000 units of last year to 400,000 units, which greatly exceeds the existing production capacity of that plant. The plant is currently actively transforming the workshop to expand its production capacity.

III. A Transfer Robot

1. Robots for transfer and shipping had begun to be developed and used by units of the Beijing Machine Tool Institute and Institute No 303 of the Ministry of Aviation Industry in the early 1980's. In 1982, Institute No 303 developed the models JJR-1400 and JJR-300 robots, which were then exported to the United States and Hong Kong. The model JJR-1400 robot was used for the fetch and carry materials for die casting machines, and made use of a programmed hydraulic driver, four degrees of freedom, and has proved reliable working on the die casting machine production line, recovering its cost within a year. The model JJR-300 is a pneumatic robot that is microprocessor controlled, and is used primarily for raising and lowering materials at a lathe.

2. The transfer robot on the FMS flexible manufacturing line as developed by Beijing Machine Tool Institute is used to raise and lower materials on a lathe. A coordinated lathe and automatic small vehicle have been working on line for more than 2 years, which has shown operations to be stable and reliable. This production line and its robot have attracted a broad interest and response from the machine tool and automation industries.

IV. A Teaching Robot

1. The GJR series robots developed by the Beijing Machine Tool Institute uses the imported Japanese FANUC technology, and is a teaching and playback model servo-driven robot. There are currently two models, the G1 and G2.

The GJR-G1 robot has six degrees of freedom, has a capacity of 5 kg, and has repeatable positioning accuracy of -0.2 mm. This machine is primarily used for spot welding, torch cutting, fur and feather removal, polishing, and transport operations, but it is also capable of automatic weld seam tracing and automatic attitude maintenance. Under microprocessor control, the robot can effect point-to-point and continuous-path control.

The GJR-G2 robot is primarily used in spot welding, the transport of heavy objects, and for raising and lowering materials on a lathe. It can hold 60 kg, and has repeated positioning accuracy of 0.5 mm.

Both models can be operated using teaching disks.

2. The all-electric continuous-path controlled isolated welding robot, the model BJM-1, was developed for the Nanjing Vehicle Manufacturing Plant by the Robotics Division of the Beijing Steel Institute. This machine is entirely electrically powered through five joints, has a maximum compounding rate of 100 mm/s, can hold 10 kg, and has a repeatable positioning accuracy less than or equal to 0.2 mm. The CPU uses two 8086's and one 8087.

3. The PJ-1 painting robot was developed by the Beijing Institute of Mechanical Industrial Automation, and is being used at the Beijing Jeep Vehicle Company, Ltd. This robot is an electrohydraulic servo model, and is controlled by the 8-bit general-purpose S-09 microprocessor.

Development of Robotics Urged

40080177 Beijing RENMIN RIBAO in Chinese 22 Jul 88 p 3

[Article by Meng Xiangjie [1322 4382 2638]: "China Urgently Needs To Develop Robots"]

[Text] After recently completing research on the strategy for developing robotics technology as organized by the State Science and Technology Commission, specialists pointed out that there is definitely no conflict between the development of robots and labor employment, and that China urgently needs to develop robots.

As the experts said, robotics technology has become a "rising sun industry" at present in industrially developed nations. In the United States, birth-place of robotics, the development of robots has become a phenomenon of reindustrialization; and in Japan, called the "kingdom of robotics," robotics entered a stage of universality in the 1980's. The North American Robotics Society predicts that by 1990 the expected world production of robots will reach 130,000-140,000.

We in China began to study robotics technology in the 1970's, at which some 2,000 people were engaged. Since 1972, some units in Shanghai, Beijing, Tianjin, and Liaoning have come up with about 150 robots. But when compared with foreign countries, there is still a gap of from 20 to 30 years.

The experts say that some people are worried that with so many people in China, if we were to use robots that would lead to an even greater employment problem. In reality, it would not be this way. In 1985, 4,000 people in the United States left their former work positions because of the use of robots, but new work attracted more than 12,000, which results in a net increase of more than 8,000 job opportunities. It is about the same way in Japan. This is because the advanced production technology that robots represent has opened up the limits of production, which has caused a shift in productivity, and has increased employment opportunities.

The experts predict that by the year 2000, there will be about 770 million people of working age in China, and all things considered, we must find employment for no fewer than 680 million of them. Calculating on an average annual growth in labor productivity of 5 percent, by the year 2000, about 630 million people will be employed in China, so at least 50 million will not be able to find work. If by the end of this century we could make use of 3,000 robots, we could realize a net gain of more than 7,000 opportunities for employment. At the same time, the robots can effectively increase productivity by about a factor of 3, cut production costs by 25 percent, and take the place of people in extreme working conditions.

The experts stressed that it is not only possible to develop robots in China, but that it is a requirement for social and economic development. First of all, the machine building industry requires robots. The former Ministry of Machine Building once did a survey and forecast that predicted

by 1990 the potential market demand for industrial robots in China would be 2,000-3,000. Second, the cry of workers in poisonous, hazardous, and dangerous environments to use robots is greatest. The industrial sectors of electronics assembly, offshore development, nuclear industries, aeronautics, and astronautics all need to develop robots.

12586/6091

Time-Resolved Fluorescence, Energy Transfer of Cu^+ -Doped Fluorophosphate Glass

40090128a Shanghai GUANGXUE XUEBAO [ACTA OPTICA SINICA] in Chinese Vol 8 No 6,
Jun 88 pp 481-487

[English abstract of article by Liu Huimin [0491 1979 3046], et al., of
Shanghai Institute of Optics and Fine Mechanics, Chinese Academy of Sciences]

[Text] Time-resolved fluorescence of Cu^+ in fluorophosphate glass by excitation at different wavelengths has been conducted at room or low temperatures. The fluorescence lifetimes at different emission wavelengths have also been determined. The peak position of the fluorescence spectra shifts to a longer wavelength with an increase in the delay time. However, by excitation at long wavelengths, some additional peaks rise on each side of the original one, showing the energy transfer among activated ions.

9717

Resonance Ionization Spectra of Ba₂ Excimer, Study of Ionization Mechanism

40090128b Shanghai GUANGXUE XUEBAO [ACTA OPTICA SINICA] in Chinese Vol 8 No 6,
Jun 88 pp 488-493

[English abstract of article by Wu Donghong [0702 2639 1347], et al., of the
Institute of Atomic and Molecular Physics, Jilin University, Changchun]

[Text] The new structures of the Ba₂ excimer are presented. The authors
have observed the two-photon transition of BaI, the Ba₂ band and two-photon
hybrid transition. A new method is proposed for analyze the ionization
mechanism of the Rydberg states of atoms and molecules with thermionic diodes,
and the ionization channels of BaI and Ba₂ are discussed.

9717

Four-Level Atomic System Resonantly Pumped by Double-Wave Fields*

40090128c Shanghai GUANGXUE XUEBAO [ACTA OPTICA SINICA] in Chinese Vol 8 No 6,
Jun 88 pp 494-501

[English abstract of article by Luo Gengxian [5012 5087 6343], et al., of the
Department of Physics, University of Science and Technology of China, Hefei]

[Text] A four-level atomic system interacting with two laser fields and one
probe field has been transformed into a four-level Dressed-Atom System inter-
acting with a weak probe absorption field by means of the Dressed-Atom states.
Using the perturbation theory to solve the density matrix equations in the
Dressed-Atom representation, the analytic expressions for the absorption
spectrum are obtained. The properties of the absorption spectrum are discussed
in detail. Finally, the induced electric dipole moment between the atomic
levels and its relationship with the absorption spectrum are deduced.

* Projects supported by the Science Fund, Chinese Academy of Sciences.

9717

Raman Beam Cleanup of Excimer Laser Radiation*

40090128d Shanghai GUANGXUE XUEBAO [ACTA OPTICA SINICA] in Chinese Vol 8 No 6, Jun 88 pp 502-508

[English abstract of article by Luo Qihong [2869 4388 3163], et al., of Shanghai Institute of Optics and Fine Mechanics, Chinese Academy of Sciences]

[Text] Stimulated Raman scattering is one of the methods used to shift the UV excimer laser radiation into specific wavelengths in the near UV and visible regions. Diffraction-limited first Stokes output can be obtained by means of Raman beam cleanup. The effects of the beam quality of the injected emission on the Raman beam cleanup is investigated in this paper. The Raman gain coefficients and the saturated parameters of the Raman amplifier have been deduced for different H₂ gas pressures.

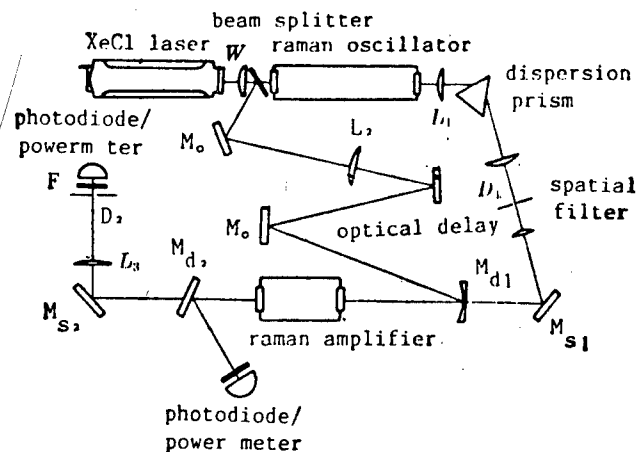

Schematic of the Raman Beam Cleanup Experiment

* This work was supported by the Natural Science Foundation of China.

New Method for Establishing 3-D Optical Diffraction Integrals for Focusing Optical Systems

40090128e Shanghai GUANGXUE XUEBAO [ACTA OPTICA SINICA] in Chinese Vol 8 No 6, Jun 88 pp 521-526

[English abstract of article by Ruan Yu [7086 3768], et al., of the Department of Optical Engineering, Huazhong University of Science and Technology]

[Text] In this paper, a new method for establishing three-dimensional optical diffraction integrals for focusing optical systems is presented. The method is simple. With these integrals, the vectorial properties of the focused diffraction field of the optical systems, especially large aperture optical systems, can be easily and effectively studied. Distributions of the light vector and its components on the focal plane of the optical system are given. The impact of aberrations on the distributions of the light vector and relationships between the distributions and the symmetry of the aberration are also studied. Some conclusions are reached.

9717

New Method for Interference Fringe Scanning

40090128f Shanghai GUANGXUE XUEBAO [ACTA OPTICA SINICA] in Chinese Vol 8 No 6,
Jun 88 pp 527-533

[English abstract of article by Cai Bo [5591 3134] of the Institute of Optics
and Electronics, Chinese Academy of Sciences]

[Text] A new method for fringe scanning is given. In this method, the phase modulation is completed by inserting a rotating wave plate in the light source path. In this way, the disturbance in interference paths is avoided. Compared with conventional methods, this new method has higher accuracy, higher reliability and lower cost.

9717

Wave-Scanning Inverse WKB Method for Refractive Index Profile Determination of Monomode Planar Optical Waveguide With Graded Index Refraction

40090128g Shanghai GUANGXUE XUEBAO [ACTA OPTICA SINICA] in Chinese Vol 8 No 6, Jun 88 pp 534-538

[English abstract of article by Pu Yuan [3184 6678], et al., of the Department of Applied Physics, Shanghai Jiaotong University]

[Text] The mode equation of a graded waveguide (WKB integral equation) has been divided into many segmental integrals and their terminal value points have been set at the turning points of the same mode at different wavelengths. When the differences in the wavelengths are small enough, the deviations for the corresponding turning points are also sufficiently small, enabling the broken line approximations to be made in these segmental integrals. Then, the authors theoretically obtain a recurrence formula for calculating the refractive index profile. The profile can be finally determined by picking up the smoothest one. This method is particularly applicable for monomode waveguides, and it is not necessary to presuppose the function type of the profile.

Computer simulations are made for model waveguides with the profiles of hyperbolic secants and parabolic types in this paper, and the calculation proves that the new method has a precision of 10^{-3} or even higher. The more segments divided, the higher precision can be reached.

9717

Experimental Study of Optical Second Harmonic Generation of Langmuir-Blodgett Monolayer Assembly

40090128h Shanghai GUANGXUE XUEBAO [ACTA OPTICA SINICA] in Chinese Vol 8 No 6, Jun 88 pp 567-571

[English abstract of article by Chen Gang [7115 0474], et al., of the Department of Physics, Fudan University, Shanghai; Tao Fenggang [7118 7364 1511], et al., of the Department of Chemistry, Fudan University, Shanghai]

[Text] The second order non-linear polarizability of the Langmuir-Blodgett multilayer formed with one kind of molecules is zero due to the counteraction of non-linear polarization in adjacent monolayers which have the opposite orientation. The magnitude and sign of effective non-linear optical coefficients of the Langmuir-Blodgett monolayer with different polar groups have been studied experimentally by the optical second harmonic generation technique. The authors alternately assembled the monolayers which had opposite signs of polarizability and had their non-linear polarizability superposed constructively. In this way, a molecular membrane is obtained that possesses a much larger effective second order non-linear optical coefficient.

9717

Preparation of Multilayer Soft X-Ray Mirrors

40090128i Shanghai GUANGXUE XUEBAO [ACTA OPTICA SINICA] in Chinese Vol 8 No 6,
Jun 88 pp 572-576

[English abstract of article by Zheng Tianshui [6774 1131 3055], et al., of the
Department of Physics, Fudan University, Shanghai]

[Text] In this paper, the authors describe the design and preparation method of Ni-C multilayer soft X-ray mirrors with emphasis on the thickness monitoring method. The optical coefficients of Ni and C superficial layers at 6328 Å are determined by the ATR method and, therefore, their thicknesses can be monitored by measuring the transmittance of the sample at that wavelength during deposition. The depth profile of a sample has been analyzed using AES. The diffraction performance at 1.54 Å and the reflectivities at soft X-ray regions of some samples have been measured and compared with the theoretical calculations.

9717

Design, Measurement of Quasi-Optical Millimeter-Wave System for Plasma Diagnostics

40080192b Beijing DIANZI KEXUE XUEKAN [JOURNAL OF ELECTRONICS] in Chinese
Vol 10 No 4, Jul 88 (manuscript received 1 Sep 86, revised 7 Jul 87)
pp 343-349

[Article by Shen Xuemin [3088 1331 3046] and Wang Zhaoshen [3769 0340 3947]
(Institute of Plasma Physics, CAS, Heifei)]

[Abstract] Millimeter-wave technology has received much attention recently in controlled fusion research, since millimeter-wave instruments--interferometers, radiometers, and scatterometers--can diagnose the electron density and temperature in plasmas and various physical parameters in plasma waves. The most important diagnostic instruments are millimeter-wave receiving systems, which are different from millimeter-wave receivers for communications and radar; in plasma diagnostics the received electromagnetic signals come from the metal cavity of a fusion device (tokamak, magnetic mirror, stellarator, etc.) and pass through a diagnostic window of limited aperture on the device wall. Reflection from the metallic walls and diffraction effects from the window introduce difficulties. For example, in diagnosing electron cyclotron emission in plasmas, measurement of the polarization of the radiating signals cannot be carried out due to wall reflection. To circumvent these difficulties, quasi-optical millimeter-wave systems have been gradually introduced in recent years, greatly increasing spatial resolving power. Taking as an example the quasi-optical Ka-band and V-band (central operating frequencies of 35 GHz and 62.5 GHz, respectively) system we have designed for our HT-6B tokamak, formulas and procedures for designing such a system are presented. The following figures illustrate the experimental apparatus.

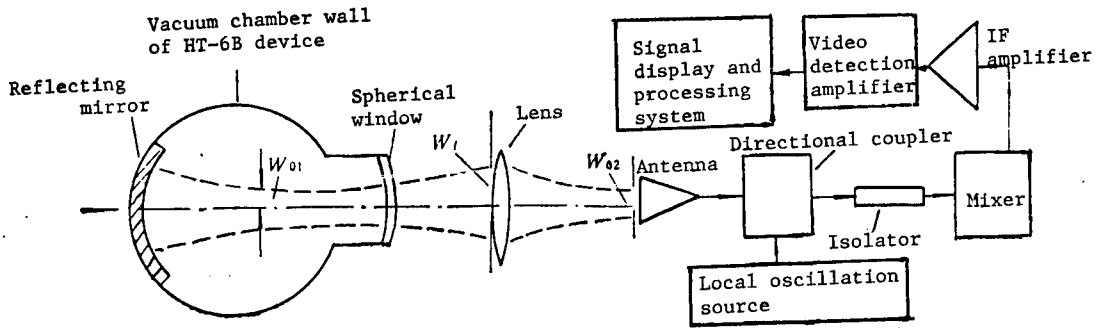

Fig. 1: Schematic of receiving system

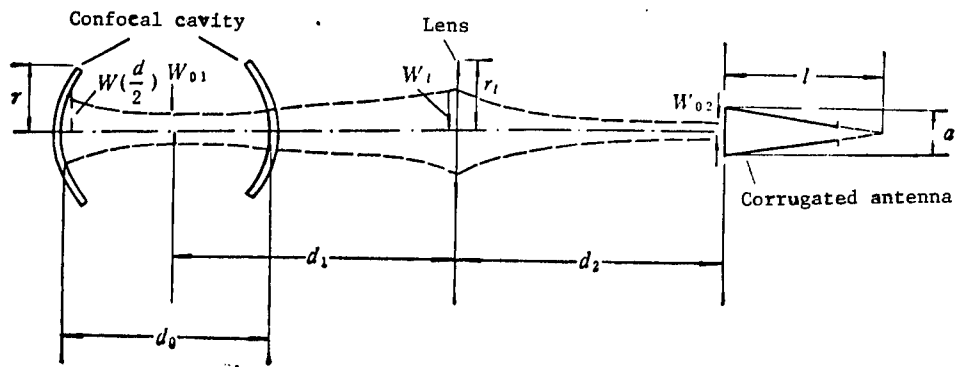

Fig. 2: Schematic of quasi-optical system

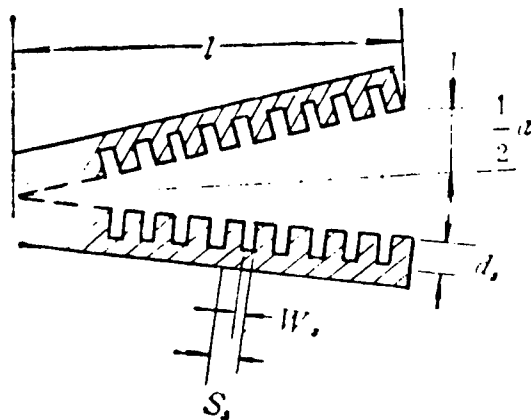

Fig. 3: Corrugated-wall circular conical horn antenna

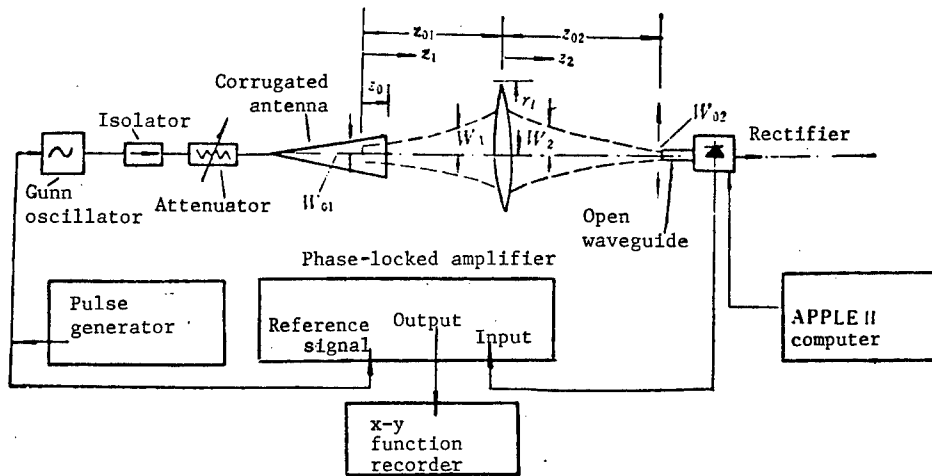

Fig. 4: Experimental arrangement of quasi-optical system for measurement

Results are as follows: When the Ka-band quasi-optical system is used in the HT-6B tokamak, a spatial resolving power of 5.0 cm (diameter near middle of the wave) can be obtained; beam diameter at the diagnostic window is 5.9 cm. If a common rectangular-corner horn antenna (5 x 6 cm aperture) is used, beam width at the diagnostic window is 6.8 cm.

References:

Wang Zhaoshen, KEXUE TONGBAO, 19(1983), 1166.
 _____, WULI XUEBAO [ACTA PHYSICA SINICA], 32(1983), 1323.
 C. X. Yu et al., "Plasma Physics and Controlled Fusion" (to be published).
 Z.S. Wang et al., BULLETIN OF THE AMERICAN PHYSICAL SOCIETY, 26-8(1981), 6022.
 J.B. Wilgren et al., BULLETIN OF THE AMERICAN PHYSICAL SOCIETY, 28-8(1983).
 Wang Zhaoshen and Shen Xuemin, "Collected Papers of the Second National Millimeter-Wave and Sub-Millimeter-Wave Conference" (1983), 443.
 H. Kogelnik and T. Li, PROC. IEEE, 10(1966), 1312.
 I. Ohtera and H. Ujiie, IEEE TRANS. ON AP, AP-23(1975), 858.
 S.K. Heald and C.B. Wharton, "Plasma Diagnostics with Microwave," New York, 1966, 330.
 J.C. Mather, IEEE TRANS. ON AP, AP-29(1981), 967.

/12223

Theory of Synchronously Pumped Mode-Locking Dye Lasers

40090131a Shanghai GUANGXUE XUEBAO [ACTA OPTICA SINICA] in Chinese Vol 8 No 7,
Jul 88 pp 577-583

[English abstract of article by Bao Xiaoyi [7637 2556 3015], et al., of the
Laboratory of Laser Spectroscopy, Anhui Institute of Optics and Fine Mechanics,
Chinese Academy of Sciences]

[Text] In this paper the authors extend the theory of synchronously pumped mode-locking and obtain the precise solution, i.e., the supermodes solution. The physical meaning of the supermodes solution is given. Under the condition of the lowest supermodes, the analytical expressions for pulsewidth, intensity and peak position are deduced. The effect of noise on the supermodes solution of the synchronously pumped mode-locking dye laser is studied. Expressions for the noise spectrum, a method for evaluating the noise source and the noise to signal ratio are also obtained.

9717

Anisotropy of Ion Emissions in Laser-Plasma Interaction

40090131b Shanghai GUANGXUE XUEBAO [ACTA OPTICA SINICA] in Chinese Vol 8 No 7,
Jul 88 pp 584-589

[English abstract of article by Sun Lan [1327 1526], et al., of Shanghai
Institute of Optics and Fine Mechanics, Chinese Academy of Sciences; Xu Zhizhan
[1776 5267 1455] of the Center of Condensed Matter and Radiation, CCAST
(World Laboratory), Beijing]

[Text] Ion emission anisotropy was observed when laser irradiation of aluminum
or gold targets at a 1.06 μm wavelength with a laser intensity of 10^{12} to
 10^{14} W/cm² and spot-focused and line-focused configurations were applied.
The scaling law of ion velocity and mass ablation have been studied through
analysis of the ion emission, anisotropic angular distributions of ion velocity
and momentum.

9717

Investigation of Dislocation Properties, Motion in YAG by Means of X-Ray Transmission Topography With AgK_α Radiation

40090131c Shanghai GUANGXUE XUEBAO [ACTA OPTICA SINICA] in Chinese Vol 8 No 7, Jul 88 pp 625-630

[English abstract of article by Deng Peizhen [6772 0160 3791], et al., of Shanghai Institute of Optics and Fine Mechanics, Chinese Academy of Sciences]

[Text] The properties and distribution of defects in Nd:YAG crystals have been successfully obtained by means of X-ray transmission topography with AgK_α radiation. It is shown that several kinds of defects, such as growth striations, precipitated particles, edge dislocations, screw dislocations and mixed dislocations, formed by dislocation motions, exist in Nd:YAG crystals grown by CZ and temperature gradient techniques (TGT). Some of the experimental results are consistent with the results obtained by optical methods, however, the X-ray method is particularly advantageous in discriminating the properties of the dislocations.

9717

Study of Defects in Nd:YAG Crystals by Darkfield and Phase Contrast Microscopy

40090131d Shanghai GUANGXUE XUEBAO [ACTA OPTICA SINICA] in Chinese Vol 8 No 7,
Jul 88 pp 636-642

[English abstract of article by Deng Peizhen [6772 0160 3791], et al., of
Shanghai Institute of Optics and Fine Mechanics, Chinese Academy of Sciences]

[Text] The resolution of Darkfield and Phase Contrast Microscopy is up to 10-500 Å. The fine structure of point defect clusters, small dislocation loops and helical dislocations in Nd:YAG crystals can be observed very clearly by these techniques. In particular, images of undecorated edge dislocations and mixed dislocations in crystals have been obtained. The observation of undecorated dislocations was confirmed by chemical etching, optical birefringence and X-ray topography.

9717

Photoacoustic Study of Spectral Absorption of Optical Films

40090131e Shanghai GUANGXUE XUEBAO [ACTA OPTICA SINICA] in Chinese Vol 8 No 7, Jul 88 pp 643-647

[English abstract of article by Jin Gang [7246 0474], et al., of the Institute of Mechanics, Chinese Academy of Sciences]

[Text] Taking into consideration the absorption that takes place during the back and forth passages inside optical films and the fact that optical films are "thermally thin" in photoacoustics, a photoacoustic expression for optical thin films is deduced according to the one-dimensional heat-flow piston model. The amplitude of the photoacoustic signal is proportional to the absorptivity of the film. Some photoacoustic absorption spectra of films on glass are measured and are in agreement with the theoretical expression. This photoacoustic spectral method exhibits high sensitivity and precision, and is particularly suitable for measuring the absorption spectra of weakly absorbing films.

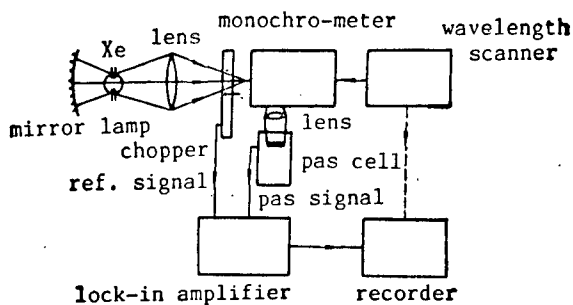

Figure 1. Experimental Arrangement

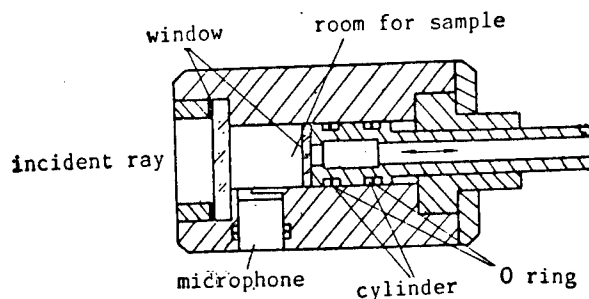

Figure 2. Construction of Photoacoustic Cell

BRIEFS

New Military Radar System--The "Improved Medium-Range Low-to-Middle-Altitude Warning Radar System" developed by the Beijing Radio Measurement Institute of the Ministry of Aeronautics & Astronautics was certified at the ministry level on 29 July. This project was established for the purpose of replacing the old-style radar now in active service in the military and developing a new model of radar. The new improved system, utilizing a series of advanced technologies and equipment, has increased effective range and greatly increased clutter suppression and sensitivity. It is stable and reliable, has a rational layout, is highly mobile, and has strong automatic detection functions. It is comparable to similar imported products, and [its domestic manufacture] can save greatly on foreign exchange. Specialists at the accreditation noted that this system meets advanced international standards of the eighties for products of its type. [Text] [40080193 Beijing GUANGMING RIBAO in Chinese 2 Aug 88 p 2]

New Air Force Camera--The PLA Air Force has recently developed a camera for high-altitude aerial reconnaissance photography from supersonic fighters. The equipment, a major breakthrough by the PLA Air Force in aerial reconnaissance photography, has met the needs of the new fighters which are currently replacing old models in the PLA Air Force. [Text] [40080191 Beijing Domestic Service in Mandarin 2130 GMT 7 Aug 88] 03586

07310

Novel CMOS Memory Elements Based on Pass Transistors

40100001 Hangzhou HANGZHOU DAXUE XUEBAO [JOURNAL OF HANGZHOU UNIVERSITY]
in English Vol 15 No 3, Jul 88 pp 374-375

[Article by Wu Xunwei and Prosser, Franklin, Computer Science Department,
Indiana University, USA. Received 5 January 1988]

[Text] The CMOS transmission gate is a typical application of the pass transistor. Two transmission gates with complementary controls can form a 1-of-2 multiplexer, as shown in Figure 1a. Two special cases are of interest: if $c_0 = 0$ and $c_1 = y$, the output is $x \cdot y$, and if $c_0 = y$ and $c_1 = 1$, the output is $x + y$. The AND and OR gates arising from these cases are shown in Figures 1b and 1c. Where 0 or 1 is transmitted, the unnecessary PMOS or NMOS transistor in the pass path has been omitted. These gates save one MOS transistor in comparison with the traditional scheme of a NAND gate or NOR gate plus an inverter. The inputs are treated asymmetrically in these gates, yielding an inverse output for one of the inputs. The symbols in Figure 1 show the extra output and emphasize the asymmetry.

If the output of the AND gate in Figure 1b is fed back into the input x , then if $y=0$ the AND output is always 0 and the inverse output is 1, and if $y=1$ the circuit is a latch composed of two inverters and having complementary outputs. A similar argument holds for the OR gate in Figure 1c. If the output feeds back into the input x , then if $y=1$ the OR output is always 1 and the inverse output is 0, and if $y=0$ the circuit is a latch with complementary outputs.

Using these results, we may construct a D-latch by using the AND gate and a 1-of-2 multiplexer controlled by a clock Ck , as shown in Figure 2a. The feedback path of the AND gate is controlled by the multiplexer. If $Ck=1$ the data comes in, and if $Ck=0$ the data is stored in the latch. The other input of the AND gate can be used as a low-active clear input Clr . Two such D-latches can be used to construct a D-type master-slave flip-flop with a direct clear function, as shown in Figure 2b. The two multiplexers in this flip-flop can share an inverter. This flip-flop responds to rising transitions of the clock pulse.

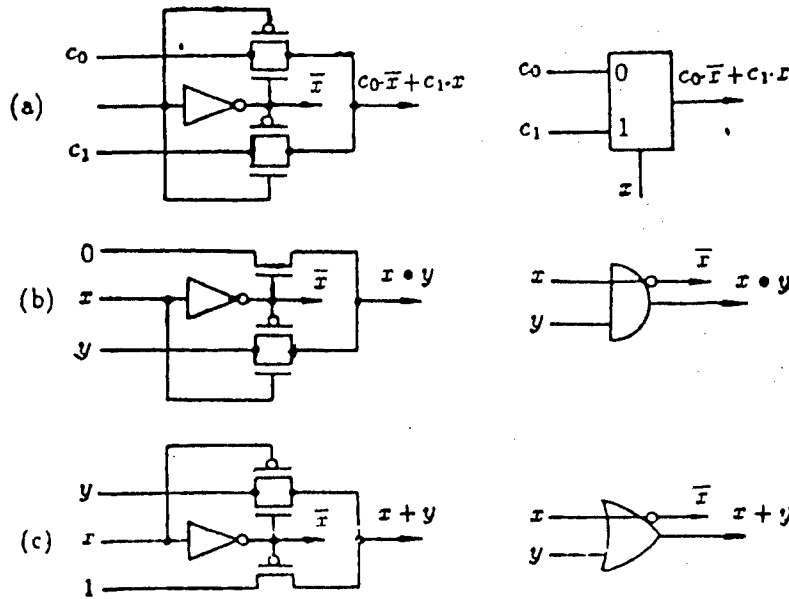

Figure 1. CMOS gates based on pass transistors: (a) 1-of-2 multiplexer, (b) AND gate, (c) OR gate.

Two additional pass transistors controlled by another input signal z can be attached to the AND gate in Figure 1b, creating the circuit shown in Figure 2c. If $z=1$ the circuit acts the same as the original gate; however, if $z=0$ the output of the AND gate will be forced to be 1. In Figure 2c, y and z act as a direct reset input R and a direct set input S , respectively. Both are low-active. (In this circuit, y and z are not permitted to both be 1 at the same time.) A D flip-flop based on this circuit will have a direct preset function.

If a pass-transistor network realizing the XOR function is attached to the input of a D flip-flop, a T flip-flop is created, as shown in Figure 2d. Here the excitation input T goes through a transmission gate if $Q=0$, and goes through an inverter to D if $Q=1$.¹

The foregoing development is based on the AND gate in Figure 1b. A similar discussion can be made based on the OR gate in figure 1c, except that the clear input and direct preset inputs are high-active.

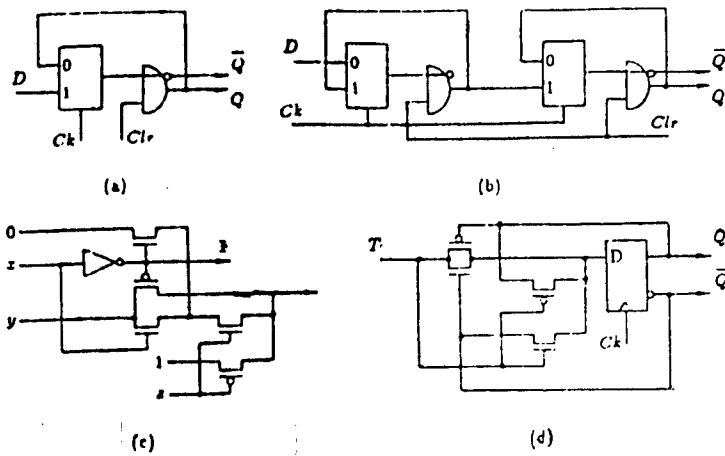

Figure 2. CMOS memory elements based on pass transistors:
 (a) D-latch with clear input, (b) D flip-flop, (c) AND gate
 with z control, (d) T flip-flop.

REFERENCE

1. Mukherjee, A., INTRODUCTION TO nMOS & CMOS VLSI SYSTEMS DESIGN, Prentice-Hall, Englewood Cliffs, N.J., 1986.

/9604

Briefs

All-Chinese-Made Super Clean Room--China's first totally domestically made super-level clean room, jointly developed by Design Institute 11 of the former Ministry of Electronics Industry [now part of the Ministry of Machinery & Electronics Industry] and Chongqing Special-Purpose Radio Equipment Plant, recently passed ministry-level technical accreditation in Chongqing. Observers noted that its main technical indicators have reached international standards of the eighties. This equipment, critical for providing the super-clean environment necessary to domestic development and production of VLSI chips, has reached the highest level of cleanliness for totally Chinese-made equipment: that of a 0.1-micron level-10 clean room, meaning that there are fewer than 10 0.1-micron-diameter dust particles in every cubic foot of air. The equipment uses the vertical airflow method and has a super-clean area of 5.76 square meters. China will no longer need to rely on imported clean-room technology, which also has applications in areas such as astronautics, nuclear engineering, and health and medicine. [Summary] [40080190b Beijing DIANZI SHICHANG [ELECTRONICS MARKET] in Chinese 14 Jul 88 p 1]

Fast Evaluation of Characteristics of Single-Mode Optical Fibers

40080192a Beijing DIANZI KEXUE XUEKAN [JOURNAL OF ELECTRONICS] in Chinese Vol 10 No 4, Jul 88 (manuscript received 5 Jan 87, revised 21 Mar 87) pp 334-342

[Article by Yang Xianglin [2799 4382 2651] (Nanjing Engineering Institute)]

[Abstract] Current methods for evaluating the transmission characteristics of single-mode optical fibers with arbitrary cross-sectional composition require complex and tedious mathematical operations, mainframe computers, and large program libraries. This situation is unsuited to engineering requirements in the development of optical-fiber transmission systems: rapid analytical design, evaluation, and parametric adjustment. A simple and direct mathematical method for fast evaluation of mode field transmission characteristics for single-mode optical fibers with arbitrary refractive-index profiles is here presented, along with a versatile BASIC microcomputer program (convertible to FORTRAN). Analysis of transmission characteristics, printout, and plotting of characteristic curves can be completed in one half hour.

Figures: 9 (one flow chart and 8 characteristic curves).

References:

- T.A. Lenahan, Bell Syst. Tech. J. 62(1983), 2663-2694.
- W.A. Gambling, H. Matsumura, Opt. Quant. Electron., 10(1978), 31-40.
- D. Marcuse, J. Opt. Soc. Am. 68(1978), 103-109.
- W.A. Gambling et al., Proc. IEE Pt. H: Microw. Opt. Acoust., 1(1976), 13-17.
- M. Nishimura, S. Suzuki Sumitomo, Measurement of Mode Field Radius by Far-Field Pattern Method, Conference on Optical Communications, 118-9, North-Holland, (ECOG'84), 3-6, Sept. 1984.

/12223

Highly Stabilized GaAs FET Oscillator Using Dielectric Resonator Feedback Circuits

40080003a Beijing DIANZI XUEBAO [ACTA ELECTRONICA SINICA] in Chinese Vol 16 No 4, Jul 88 (manuscript received Feb 87, revised Apr 87) pp 59-63

[Article by Gu Molin [7357 1075 3829] (Nanjing Institute of Electronic Technology)]

[Summary] High-Q dielectric resonator frequency-stabilized oscillators (DRO) made with GaAs FET's can operate in the X band and even shorter bands and are used as local oscillation sources in receivers for satellite ground stations, radar systems, etc. Although feedback-type FET DRO's have been described in the literature, up to now there has been no rigorous analysis of these promising devices. A model for high-precision analysis of this oscillator is presented. The relationship between the FET's S-parameters and the feedback circuit parameters under oscillation conditions is given, as is the relationship between the oscillation frequency and frequency-temperature stability. Two kinds of X-band DRO's are developed: DRO1 is a dielectric resonator feedback (DRF) FET oscillator and DRO2 is a DRF FET oscillator with a post-dielectric-resonator band rejection filter. Both can provide 10 mW output power at 10.73 GHz. In a surrounding temperature range of -30 to +50°C, DRO1 can maintain a frequency stability of ± 180 kHz, or ± 0.21 ppm/°C with an output power stability of -0.015 dB/°C. In the same temperature range, DRO2 has a frequency stability of ± 130 kHz, or ± 0.15 ppm/°C with a power stability of -0.01 dB/°C.

Figures: 4. Technical appendix.

References

1. APS Khanna, Parallel Feedback FET DRO Design Using 3-Port S-Parameters, 1984 IEEE MTT-S Intel. Microwave Symposium Digest, pp 181-183.
2. O. Ishihara et al., IEEE TRANS., Vol MTT-28, pp 817-823, August 1980.
3. Gu Molin and Liu Weisheng [0491 0251 0524], Dielectric Resonator Stabilized GaAs FET Oscillators, Proc. CIE 1986 Intel. Conf. on Radar, Nanjing, pp 647-652.

4. Gu Molin, XIANDAI LEIDA [MODERN RADAR], Vol 8, No 5, pp 121-122, 1986.
5. Y. Komatsu et al., IEEE TRANS., Vol MTT-31, pp 34-40, January 1983.
6. D. Kajfez et al., IEEE TRANS., Vol MTT-32, pp 666-670, July 1984.
7. Z. Galani et al., IEEE TRANS., Vol MTT-32, pp 1556-1564, December 1984.

/6091

BRIEFS

Satellite Earth Station Extension--Joint hearings are under way for the initial design of the extension project for the Beijing and Urumqi domestic satellite communications earth stations. This project is in preparation for the [future] launch and operation of communication satellites. After the Beijing domestic station expansion is completed, the station will have two 16-m antennas, one pointed to the international telecommunications satellite at 66° east longitude in the Indian Ocean, the other pointed toward the functional communications satellite(s) launched by China. The G/T values for both antennas meet the A-station international standard. The Urumqi domestic station will add a 14-m (or 11.6-m) antenna for linkup to the Chinese-launched functional communications satellite(s); its G/T value will meet the domestic standard. [Summary] [40080003b Beijing DIANXIN JISHU [TELECOMMUNICATIONS TECHNOLOGY] in Chinese No 7, Jul 88 p 47] /6091

Beijing-Shenyang-Harbin Fiber-Optic Line--From 18 to 20 April 1988, in Beijing, the Design Institute of the Ministry of Posts and Telecommunications accepted bids for a feasibility study for a Beijing-Shenyang-Harbin Optical-Cable Communications Trunkline project. This is the first public bidding held by the posts and telecommunications system for a project design feasibility study. [Text] [40080003c Beijing DIANXIN JISHU [TELECOMMUNICATIONS TECHNOLOGY] in Chinese No 7, Jul 88 p 47] /6091

Zhengzhou-Wuhan Fiber-Optic Line--A state-of-the-art 600-km optical-cable communications line--currently the longest such domestic line--will be built by China to connect Zhengzhou and Wuhan. This communications line is intended for the Zhengzhou-Wuhan railroad electrification project, and will be of great value in providing a high degree of centralization, safety, and precision for the railroad line's transport control. [Text] [40080190a Shanghai WEN HUIBAO in Chinese 20 Jul 88 p 1]

Weifang to Import Digital Switchboard--The Weifang Municipal Posts & Telecommunications Office, with the assistance of [Shandong] Province authorities and following ratification by the municipal government, has decided to utilize an FRG government loan to import a Siemens 12,000-switch time-division-switching digital municipal telephone exchange. In addition, the city has requested that 480 lines of the long-distance program-controlled switchboard system planned for import by the Provincial Posts & Telecommunications Administrative Office be made available for municipal use. The importing is currently proceeding smoothly. Installation of these systems will be completed in 1989 and 1990, respectively. At that time, the city will have a unified municipal telephone network; the present analog system will have been converted to a digital system with 16 times the current capacity and new services such as direct dialing of domestic and international long-distance calls will be instituted. Future requirements for services such as data communications and image communications are also being considered. [Summary] [40080005b Beijing DIANZI SHICHANG [ELECTRONICS MARKET] in Chinese 11 Aug 88 p 1]

END