

291101

JPRS 81579

19 August 1982

# China Report

SCIENCE AND TECHNOLOGY

No. 170

19981208 055

Reproduced From  
Best Available Copy

**FBIS**

FOREIGN BROADCAST INFORMATION SERVICE

REPRODUCED BY  
NATIONAL TECHNICAL  
INFORMATION SERVICE  
U.S. DEPARTMENT OF COMMERCE  
SPRINGFIELD, VA. 22161

5  
36  
A03

#### NOTE

JPRS publications contain information primarily from foreign newspapers, periodicals and books, but also from news agency transmissions and broadcasts. Materials from foreign-language sources are translated; those from English-language sources are transcribed or reprinted, with the original phrasing and other characteristics retained.

Headlines, editorial reports, and material enclosed in brackets [] are supplied by JPRS. Processing indicators such as [Text] or [Excerpt] in the first line of each item, or following the last line of a brief, indicate how the original information was processed. Where no processing indicator is given, the information was summarized or extracted.

Unfamiliar names rendered phonetically or transliterated are enclosed in parentheses. Words or names preceded by a question mark and enclosed in parentheses were not clear in the original but have been supplied as appropriate in context. Other unattributed parenthetical notes within the body of an item originate with the source. Times within items are as given by source.

The contents of this publication in no way represent the policies, views or attitudes of the U.S. Government.

#### PROCUREMENT OF PUBLICATIONS

JPRS publications may be ordered from the National Technical Information Service, Springfield, Virginia 22161. In ordering, it is recommended that the JPRS number, title, date and author, if applicable, of publication be cited.

Current JPRS publications are announced in Government Reports Announcements issued semi-monthly by the National Technical Information Service, and are listed in the Monthly Catalog of U.S. Government Publications issued by the Superintendent of Documents, U.S. Government Printing Office, Washington, D.C. 20402.

Correspondence pertaining to matters other than procurement may be addressed to Joint Publications Research Service, 1000 North Glebe Road, Arlington, Virginia 22201.

CHINA REPORT  
SCIENCE AND TECHNOLOGY

No. 170

CONTENTS

PEOPLES REPUBLIC OF CHINA

APPLIED SCIENCES

Wiretapping Techniques, Eavesdropping Devices Discussed (Yang Baogen; YIQI YU WEILAI, No 5, 1982).....	1
Personnel Aboard Tracking Vessel Prepare for Upcoming Space Shot (RENMIN RIBAO, 25 Jul 82).....	4
'New Science' Analyses Optimum Coordination Systems (Tu Xuyan; KEXUEXUE YU KEXUE JISHU GUANLI, 20 Oct 81).....	5

ABSTRACTS

AUTOMOTIVE TECHNOLOGY

QICHE JISHU [AUTOMOBILE TECHNOLOGY], No 6, 25 Jun 82,.....	13
--	----

CHEMISTRY

HARBIN GONGYE DAXUE XUEBAO [JOURNAL OF HARBIN INSTITUTE OF TECHNOLOGY], No 2, 1982.....	14
--	----

ENGINE ENGINEERING

NEIRANJI GONGCHENG [CHINESE INTERNAL COMBUSTION ENGINE ENGINEERING], No 4, 15 Dec 81,.....	15
---	----

ENGINEERING

XINXI YU KONGZHI [INFORMATION AND CONTROL], No 2, 1982..... 17

ENVIRONMENTAL SCIENCE

HUANJING KEXUE [JOURNAL OF ENVIRONMENT SCIENCE], No 2,  
30 Apr 82..... 19

HEAT TREATMENT

JINSHU RECHULI [HEAT TREATMENT OF METALS], No 6, 25 Jun 82..... 23

INDUSTRIAL INSTRUMENTATION

GONGYE YIBIAO YU ZIDONGHUA ZHUANGZHI [INDUSTRIAL INSTRU-  
MENTATION AND AUTOMATION], No 2, 5 Apr 82..... 25

MACHINE TOOLS

ZUHE JICHUANG [MODULAR MACHINE TOOL], No 6, 25 Jun 82..... 26

METROLOGY

JILIANG XUEBAO [ACTA METROLOGICA SINICA], No 3, 22 Jul 82..... 27

VACUUMS

ZHENKONG [VACUUM], No 3, 25 Jun 82..... 28

WEIGHTS, MEASURES

JILIANG JISHU [MEASUREMENT TECHNIQUE], No 4, 18 Jul 82..... 31

APPLIED SCIENCES

WIRETAPPING TECHNIQUES, EAVESDROPPING DEVICES DISCUSSED

Beijing YIQI YU WEILAI [INSTRUMENTATION AND THE FUTURE] in Chinese No 5, 1982  
p 5

[Article by Yang Baogen [2799 1405 2704]: "The Walls Have Ears--On  
Eavesdropping Techniques"]

[Text] When you mention eavesdropping, people may think of the "Watergate  
Affair" which occurred in the United States in 1972. This wasn't something  
new that Nixon thought up. The use of eavesdropping to steal political,  
military and economic intelligence, to carry out criminal investigations,  
or even to spy on private lives is an open secret in the Western world today.

Eavesdropping has become the practice in political and diplomatic struggle;  
it has a long history. But eavesdropping techniques, particularly instrument  
eavesdropping, has a history of only 30-40 years. Shortly before World War  
II, in the office of a senior officer of the U.S. Pacific Fleet, a wire  
recorder was used for the first time. This 3-foot high, 50-pound telegraphone,  
invented by the Swede, Poulsen, in 1898, was used to listen in on sailor's  
conversations. After World War II, eavesdropping equipment underwent many  
improvements, achieving qualitative leaps, through wireless electricity,  
transistors, integrated circuits, and large-scale integrated circuits, and  
a wide range of equipment was developed, leading to today's true breakthroughs  
in electronic surveillance.

Modern eavesdropping is divided into direct eavesdropping and indirect  
eavesdropping. In direct eavesdropping, a wire-connected receiver and  
microphone are used. Because this eavesdropping equipment uses a wire  
connection, it is easily exposed. One time a U.S. reporter walking in the  
park across from the White House stumbled over a wire and discovered a  
wiretap microphone under a bench. In such eavesdropping equipment, after  
several later improvements, the microphone was placed in a tiny wireless  
transmitter so that the eavesdropper could listen in by wireless receiver  
hidden tens of meters away. This kind of eavesdropping can only work with  
a wireless transmitter battery voltage of sufficient duration, for when the  
battery is dead, it is of no use.

There are many methods of indirect eavesdropping; the most commonly used are  
the following. In laser eavesdropping, a green or purple color laser, which

does not attract attention, is beamed onto glass or an automobile reflector. When people talk, the sound causes the glass in the window or the reflectors to produce tiny vibrations, so that using the optical characteristics of the incident light or reflection, what the people are saying can be determined from the reflected beam.

In microwave eavesdropping, a resonator is hidden in an object such as a lampbase, wall, table, hollowed out equipment or souvenir in the room to be listened in on. When people talk, the resonator vibrates, the waves sent back from the resonator by microwave beams are compared with the incident waves, and the sound can be reproduced. The KGB used this method with a resonator placed in the U.S. embassy. It would both interfere with U.S. embassy monitoring equipment and provide eavesdropping capability. A bug was placed in the emblem on the U.S. embassy and hung there for 7 years, by which eavesdropping on a great many secrets was achieved. After this was disclosed in May 1978, it created quite a scandal.

Miniaturized and microminiaturized listening equipment can be placed on a spider or a fly. One American company, in order to listen in on the board of directors of a competitor, placed a listening device on the back of a fly, and so that the vibration of the fly's wings would not influence listening in, the fly was given a drug so that when the fly reached its destination it died; thus conversations could be clearly heard within 5 meters. To be able to listen in at even greater distances, an intermediate automatic wireless reconnaissance station can be used to collect signals which are scattered in the vicinity. This is called the mother-child eavesdropping method. The U.S. CIA has drawn up plans for a "pyramid" which uses three synchronized satellites to listen in on spy stations throughout the world and naturally includes this listening device.

Advanced amplifiers can make very weak signals millions of times stronger. If a miniature microphone is placed in the bore of a "shotgun," that is, in the focal point of the dish, it can listen in on the direction in which the "shotgun" is pointed. Such a highly sensitive listening device is generally used in automobiles of diplomatic personnel. Using this listening device, one can listen in on conversations in a building across the street over the noise of the busy street.

Lip-reading is another method of listening in. If you can record the oral expressions of talkers using a motion picture camera, you can use lip-reading analysis to determine the content of the conversation.

Another method of listening in is telephone eavesdropping. In foreign countries, the police bureau or telephone bureau has a secret telephone eavesdropping room where it can use secret telephone extensions to monitor telephone conversations at any time and even record them. In addition, the telephone itself can be turned into a tool for listening in on conversations, for in addition to placing a listening device inside the telephone, the use of a new listening device called a harmonica is even more dangerous. This device uses existing telephone lines to listen in. When the United States first used this, a harmonica tone was used to activate it, so it came to be called a harmonica listening-in device.

Although the constitutions in capitalist countries stipulate clearly that eavesdropping is illegal, the constitutions do not prohibit the sale of listening devices. Thus in many countries sophisticated and ingenious listening devices are openly sold on the market. To listen in on the financial secrets of a certain company, a Japanese bank put a listening device in the false teeth of the company's chief accountant and so achieved its aim of obtaining secrets. In Cologne, West Germany, the police seized over 200 miniature listening devices and 50,000 parts in a jewelry store.

If there's a spear, there must be a shield. The development of listening techniques must lead to research and development of counter listening techniques. The secret struggle of listening and counterlistening will become increasingly fierce.

The complexity of international struggle awakens us to the fact that we cannot lower our guard but must maintain state secrets.

Fig. 1. Several listening devices.

(From left to right) Telephone wiretap recorder, Miniature listening device, Miniature transmitter.

8226

CSO: 4008/190

APPLIED SCIENCES

PERSONNEL ABOARD TRACKING VESSEL PREPARE FOR UPCOMING SPACE SHOT

Beijing RENMIN RIBAO in Chinese 25 Jul 82 p 1

[Photograph and Caption]

[Text] National defense science and technology personnel are hard at work to accelerate the modernization of China's armed forces. Here, they are conducting rocket test flight experiments aboard a Chinese-designed and built large range instrumentation vessel.

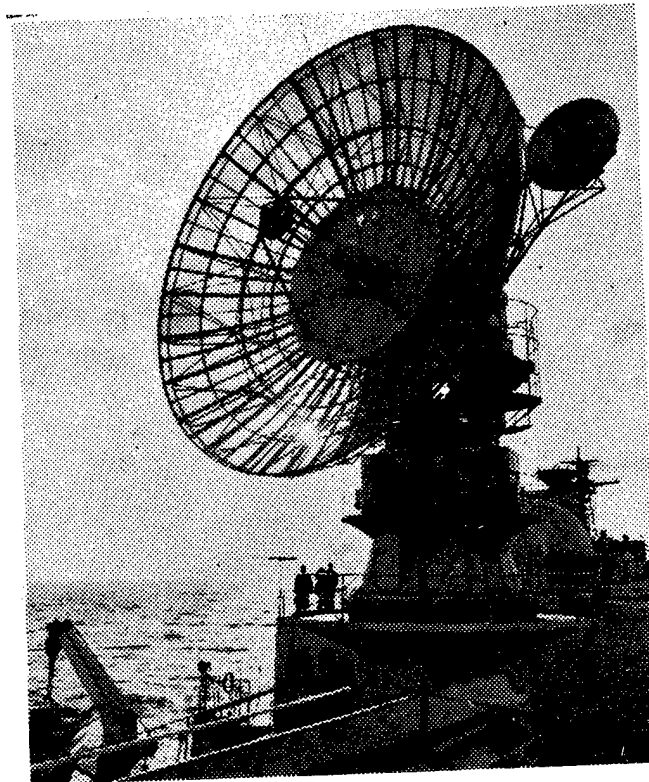

CSO: 4008/211

'NEW SCIENCE' ANALYSES OPTIMUM COORDINATION SYSTEMS

Tianjin KEXUEXUE YU KEXUE JISHU GUANLI [SCIENCE AND MANAGEMENT OF SCIENCE AND TECHNOLOGY] in Chinese No 5, 20 Oct 81 pp 17-20

[Article by Tu Xuyan [3205 1645 1750] of the Automation Institute, Chinese Academy of Sciences: "On 'Coordination'"]

[Text] Coordination is a common problem in the three major fields of engineering technology, social economy and biological ecology. Coordination among local subsystems in a large system means not only to achieve mutual constraint but also mutual support and promotion and to achieve the optimization of the entire system. It is therefore highly significant to develop the study of coordination and explore the principles of coordination in order to improve the level of scientific management and speed up the construction of the four modernizations.

I. Coordination in Engineering Control

As science and technology progress, the process of production is becoming more and more complex. As automation progresses from a single machine to a group of machines, control theory also develops from a single variable theory to a multiple variable theory. Coordination in engineering control is the study of the principles and methods of coordination in multiple variable control systems.

In a multiple variable system, even if each individual variable is controlled to operate reliably according to its purpose and requirement, it is still a big question whether the multiple variable system composed of these individual variables can operate normally. It often happens that the entire system cannot function normally because of the interaction between variables. For example, in a multiple variable controlled boiler engine system, even if individual variables such as temperature, pressure, flow rate, liquid level and revolution speed are properly controlled, there may still be many problems in the operation of the entire system. Temperature adjustment affects pressure, flow rate adjustment disturbs liquid level, and so on. It is therefore necessary to look at the overall situation and correctly handle the coupling between the thermodynamic, fluid and mechanical structures in the control process.

In order to eliminate the mutual interaction between the variables due to coupling, people have proposed the "autonomous adjustment" principle of a multivariable control system, also known as the control principle of no interaction. In this principle, the "coupling" between the controllers is used to completely cancel the "coupling" between the controlled variables, thereby making the single variable control process independent of each other and resolving the multivariable control system into "autonomous" single variable control systems. Under certain circumstances, such "autonomous adjustment" has been proven effective.

In many cases, however, the requirement is not an "autonomy" of various control processes but a "coordinated relationship" between various control processes. In the production process of chemical engineering and pharmaceutical preparation, for example, a certain ratio must be maintained in the composition. In an electrical power system, power should be distributed according to load. In continuous steel rolling and paper making by the parts, the speed of the various machines must be coordinated. Besides, coupling between the controlled variables is not always undesirable. In the attitude control system of an artificial earth satellite, the coupling effect is used to solve the rudder deflection angle measurement problem. Beneficial coupling may be used to improve system performance, simplify the control system, and reduce the production cost. If all couplings are eliminated, no matter whether they are beneficial or hazardous, the entire system will be complicated and the cost will go up. Certain strong couplings are very difficult to decouple, and the residual coupling may cause oscillation and lower the system performance. We therefore propose a "coordinated control" principle for multivariable control systems. It consists of the following: make use of or strengthen beneficial couplings, eliminate or decrease undesirable couplings, build up a coordinated relationship among the controllers, control the system according to deviation from coordination, coordinate the control process of variables, maintain the necessary coordination, accelerate the coordinated control process and achieve the overall optimization of the entire multivariable control system.

There are many ways to achieve coordinated control, for example:

#### 1. Lead Coordination.

In a multiple variable control process, one variable is made the leading variable and the other variables are controlled and coordinated on the basis of the leading variable. In leading coordination there is only unidirectional flow of coordination signal, as shown in Figure 1(a).

#### 2. Self-coordination.

As shown in Figure 1(b), various variables lead each other and form a complete bidirectional flow of coordination signal. Based on a self-adjusted internal given quantity, coordinated control is carried out for all variables.

In actual practice, the method of coordinated control takes various forms and may be a combination or modification of the two proposals above.

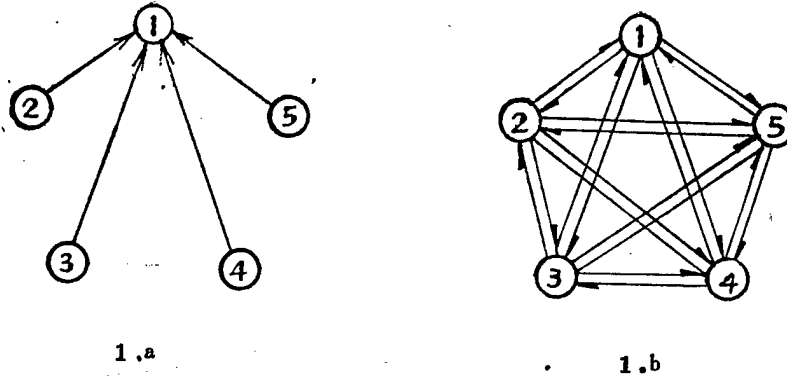

Figure 1. Vector diagram of coordinated control signal.

## II. "Resolution-Coordination" Method in Large-Scale System Theory

In large-scale systems which have a complex structure, generalized functions and numerous factors, the direct application of optimization control theory and management method in the hope of solving the dynamic optimization and static optimization of a large system in one stroke will not only involve a huge amount of analysis but is also very difficult to carry out technically. Therefore, a "resolution-coordination" method is developed for large systems.

Resolution--Resolution here refers to resolving a complex large system into simpler small systems. It includes objective resolution and model resolution. Either "actual resolution" or "nonactual resolution" may be used. On each small system, optimization control theory or management method may then be applied directly in solving its local optimization problem.

Coordination--On the basis of locally optimized small systems, mutual interaction and influence are taken into account and the overall optimization of the entire system is realized through coordinated control. Here one also has objective coordination and model coordination. Coordination principles such as "correlated equilibrium" and "correlated pre-estimate" are used and closed-loop feedback control is carried out based on deviation from coordination.

The "resolution-coordination" method solves the optimization problem of large systems in two steps. In the first step, the whole is broken up into parts, and in the second step, the parts are gathered into a whole. In this process, resolution and coordination reinforce each other and conflicts are unified.

To achieve an integrated automation of the production process, the "resolution-coordination" method may be used in solving the optimization problem of enterprise management and process control. In general, large systems are organized according to a "multilevel staged control" structure. Figure 2 shows a three-level staged control proposal. The third level (the lowest level) consists of local controllers, and local automation and optimization of small systems are solved. The second level (intermediate level) bridges the lowest and the highest levels and consists of various stage controllers. The second level accepts coordination control from the upper level and coordinately controls the lower level. The first level (the highest level) is the coordination

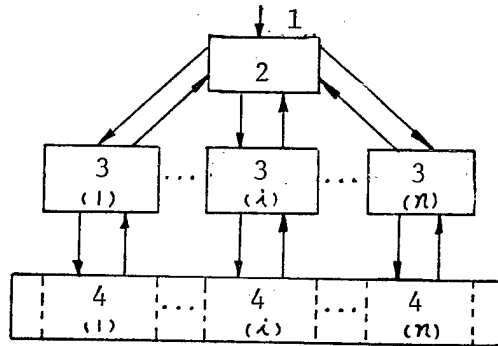

Figure 2. Multilevel staged control plan.

Key:

- 1. Overall mission
- 2. Coordinator
- 3. Local controller
- 4. Subprocess

controller. Based on the overall objective and mission of the large system, the first level carries out coordinated control of the lower levels and accomplishes the automation and optimization of the large system.

This multilevel control has the advantages of both "centralized" control and "distributed" control. It can conduct coordination effectively with a high system reliability, and the scheme can be easily carried out with a micro-processor network. For this reason, it is an organization plan widely used in large systems.

### III. "Planned Coordination" Technique (PERT) in Scientific Research Management

In large-scale research and development tasks, an operational procedure based on specific goals, timetable and undertaking departments is drawn up and a network model is established. The "planned coordination" is an organization management technique that makes use of the network model (project flow diagram), deploys the manpower, material and financial resources rationally and effectively, and accomplishes the mission in the best and fastest way.

The procedure of planned coordination is as follows:

1. Based on the overall mission, objective and proposal, the entire process from job assignment to mission accomplishment is divided up. Specific tasks of each operational procedure are determined, "items" at the beginning and end of each operational procedure are marked, anticipated time of completion of each procedure is estimated, and a "project flow diagram" is drawn up to depict the entire process.

2. Based on the project flow diagram, the earliest anticipated starting time, the latest permissible completion time and the relaxation time of each event are calculated,

3. The "emergency line" (or the "key line") that takes the longest time to complete the job is located and marked with double line. In Figure 3, this is (1)→(3)→(4)→(5)→(6)→(14).

4. Other nonemergency lines are adjusted and personnel, material and funds are rationally arranged, making sure the emergency line can be completed in time or ahead of schedule.

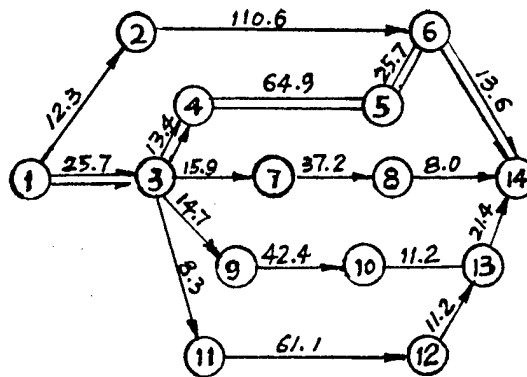

Figure 3. Project flow diagram.

5. The planned time of the task and its probability are calculated.

Even after the work actually begins, necessary coordination can be made frequently based on all the newest information in order to optimize the procedure and make the overall progress the fastest (time optimization) for the given resources or spend the least amount of manpower, material and money (resource optimization) for a specified progress.

#### IV. The "Multi-Level Coordination" of the Human Body System

After a long period of biological evolution and natural selection, the biological control system of a human body has acquired a multilevel coordination control function. One of the important features of the biological regulatory system is the "dual" regulation in coordinated control. For example, the blood pressure is under the "dual" regulation of the sympathetic nerve and the parasympathetic nerve, and the blood sugar level is under the "dual" regulation of insulin and glucagon. In addition, in the multilevel control of the nerve-liquid system, there is "rapid" control by the nerve and "slow" control by the liquid, as well as coordinated "regional" control and "functional" control. Also, in the theory of traditional Chinese medicine, the question of "coordination" is stressed. Jing-luo has the ability to "coordinate yin-yang and equilibrate fulfillment and emptiness." The so-called "jing-luo" is actually the human control system that governs the life activity. The brain is the

"home of the primary spirit" and is the highest control of the jing-luo system. The "governing pulse" controls all the yang-jing in the body and the "passive pulse" controls all the yin-jing in the body; these are second level controls. The third level control is the 12 jing-pulses made up of 6 yang-jing and 6 yin-jing. All the large and small luo-mai and sun-mai distributed all over the body are the low level local controls. Through the multilevel coordinated control of yin-yang and the five elements, the jing-luo system upholds the spirit, repels evil, determines life and death, and controls the normal activity of the human body,

#### V. Coordination of the "Man-Machine" System

"Man-machine" coordination is the key question in "man-machine" engineering (or, engineering psychology). By studying the interaction of man and machine and coordinating the man-machine relationship, an optimum match can be achieved between the characteristics of man and the characteristics of the machine.

For "man-machine" coordination, one needs to study man as well as machine. Based on the control properties of man and machine (signal transmission, conversion and processing characteristics), a "man-machine" interface can be properly designed. See Figure 4.

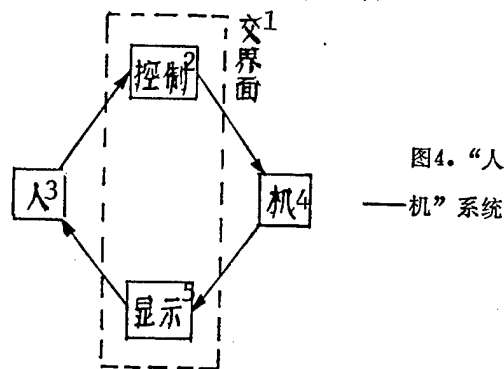

Figure 4. "Man-machine" system.

Key:

1. Interface
2. Control
3. Man
4. Machine
5. Display

The "man-machine" interface consists of a "display" and a "control" mechanism. For example, in the "man-machine" system of the pilot and the airplane, the interface is the instrument panel and the control rod.

In "man-machine" engineering, qualitative and quantitative studies should be carried out in designing the interface. Signal input and output characteristics of "man" should be tested and analyzed. Based on extensive actual data, display instruments can then be designed. The control mechanism is designed so that the signal input and output characteristics of the machine match those of the man and achieve "man-machine" coordination.

## VI. Coordination in Social and Economic Fields

Lack of coordination in social and economic fields causes a number of problems, such as social unrest and lack of unity, internal conflicts in people, unbalanced production and consumption, unbalanced financial revenue, economic deficit, and unbalanced import and export in trade. It is often claimed that the key to coordination is management. Management problems include irrationality and shortfalls in the management system, lack of a sound basis for management policy, unscientific management method and uncoordinated management practice. Improvement of management lies in the coordination of all parties involved.

Coordination and balance are stressed in sociology and economics, and many publications in social and economic science frequently discuss the question of coordination. However, most of the discussions are qualitative and consist of descriptive studies or description of experience; very few are quantitative analyses or studies using modern scientific methods and tools such as control theory, system theory, information theory or the electronic computer.

Whether the subject is engineering technology, biological ecology or social economics, there are certain common rules and features in coordination. A new topic for natural scientists, social scientists and economists is the question of whether one can borrow the principles, methods and techniques of coordination in engineering technology that have been proven effective and use them in the fields of sociology and economics by analogy, and whether new principles and methods can be developed for sociology, economics and engineering through the inspiration of studying the coordination in biological control systems.

Because of the enormous size and the many factors involved, the situation in sociology and economics is very complex. For "active systems" where the human factor is involved, man's initiative must be taken into account so that the activity and creativity of man can be fully developed. People have used the method of "response theory" in studying the "cooperation" problem by members of an active system. It is believed that the "fair play" principle can be used in formulating an optimum plan for an economic system to the satisfaction of all members. In addition, because of the ambiguity of human language and behavior, the methods of "ambiguity mathematics" have also been used in the study of social systems, such as how to assign jobs to workers so that each member can be most effective and the entire organization can be coordinated to achieve the maximum efficiency.

Coordination is a problem common to engineering, biology, sociology and economics. Is it possible to develop a cross-discipline fringe science called

"coordination science"? This new science would include qualitative as well as dynamic and static analysis of various coordination processes such as the "coordinatability" of systems, the stability and speed of coordination processes, the accuracy of coordination control, and the reliability and economics of coordination systems. Various coordination systems would be integrated in designing the optimum efficient coordination system.

(Edited by Song Hezhou [1345 3109 3166])

9698

CSO: 4808/87

AUTHOR: SHI Zengjiang [0670 2582 3068]

ORG: None

TITLE: "New Energy Saving Product, the X6130 Diesel Engine, Produced by Hangzhou Automobile Engine Plant"

SOURCE: Changchun QICHE JISHU [AUTOMOBILE TECHNOLOGY] in Chinese No 6, 25 Jun 82  
p 21

ABSTRACT: A new Huanghe brand JN-162 10-ton diesel truck is being shown in the new-product exhibition of the Ministry of Machines No 1. This truck is installed with the X6130 diesel engine, a 1981 new product of the Hangzhou Automobile Engine Plant. The plant was requested by the Machine Committee of the State Council to design engines that meet the requirements of 4-modernization construction and energy conservation, for the Huanghe Brand 10-ton truck and 20-ton tractor newly developed by Jinan Automobile Manufacturing Plant and for other machineries of engineering construction. The major characteristic of the X6130 is its low oil consumption, high horsepower rating, light weight. Its external size is basically identical (slightly smaller) with the old product, the 6120. The maximum power is 210 horsepower/2100 rotation/minute. The maximum torque is 80 kg·m (1400 rotations/minute). The minimum diesel oil consumption is only 163 g/horsepower hour. As the power and torque are raised 30 percent, compared with the 6120, the oil consumption is reduced 8.5 percent. The X6130 uses a high heat efficiency direct spray burn system. Many measures are adopted to improve the strength of its structure.

AUTHOR: HUA Yuxiang [5478 3768 4382]

ORG: None

TITLE: "The EQ140S5 Large Passenger Car Chassis Will Soon be Produced"

SOURCE: Changchun QICHE JISHU [AUTOMOBILE TECHNOLOGY] in Chinese No 6, 25 Jun 82  
p 57

ABSTRACT: The EQ140S5 large passenger car chassis, designed by the Automobile Plant No 2 will soon be officially put into production. The chassis is 8.66 m in length. It may be used to install large, long distance, 45-passenger buses. It has the EQ140 engine, the transmission and hanging systems. Its advantages include large horsepower rating, high speed, and low oil consumption. It is also safe and reliable. Last year, the Automobile Plant No 2 dispatched many technicians to survey the market of many places, to listen to the opinions of passenger bus assembly plants of the Ministry of Transportation, etc. to learn the fact that the JT662 large passenger bus is in the greatest demand in the country. With the support of many passenger car assembly plants, the Automobile Plant No 2 completed the work of designing and experimenting in a very short time to make this chassis with the JT662 as the chief target. This chassis has been included in this year's new product production plan.

6168

CSO: 4009/376

Chemistry

AUTHOR: ZHOU Ding [0719 1353]  
FAN Ailing [5400 1947 0109]  
HUANG Rongtai [7806 2837 3141]

ORG: All of the Department of Chemistry

TITLE: "Research on Al-Mg-Zn Alloys Used as Material of Expandable Anode for Protection of Underground Oil Pipelines"

SOURCE: Harbin HARBIN GONGYE DAXUE XUEBAO [JOURNAL OF HARBIN INSTITUTE OF TECHNOLOGY] in Chinese No 2, 1982 pp 114-115

TEXT OF ENGLISH ABSTRACT: Based on our research, in 1963 the author of this paper was the first in China to study and suggest Al-Mg-Zn alloys be used as material of expandable anodes for protecting the underground oil pipeline. The industrial experimental application of the Al-Mg-Zn sacrificed anodes was done at Daqing in 1965. Good results were obtained in the pipeline has been well protected until the present time. In 1975, Al-Mg-Zn anodes were adopted again to protect the underground Fangshan-Beijing pipeline (236 km) from corrosion.

9717  
CSO: 4009/367

Engine Engineering

AUTHOR: SHENG Xian [4141 6343]

ORG: None

TITLE: "Heat Machine Pneumatic Thermodynamics, Engineering Thermodynamics, and Energy Conservation Conference Held"

SOURCE: Shanghai NEIRANJI GONGCHENG [CHINESE INTERNAL COMBUSTION ENGINE ENGINEERING] in Chinese No 4, 15 Dec 81 p 22

ABSTRACT: The Heat Machine Pneumatic Thermodynamics, Engineering Thermodynamics, and Energy Conservation Conference, jointly sponsored by Chinese Engineering Thermodynamics Society and Chinese Aviation Society was held in Xiamen on 19-23 Aug 81. More than 100 papers were read. Dr. Liu Ruisen of France attended by invitation and delivered a report, entitled "A Method of Calculating Ternary Flow." A Heat Transfer, Mass Transfer, and Burn Science Conference, jointly sponsored by Chinese Engineering Thermodynamics Society and Chinese Aviation Society was held in Huangshan of Anhui Province on 16-22 Oct 81.

AUTHOR: ZHU Xueguo [2612 1331 0948]

ORG: None

TITLE: "National Standard and Ministry of Agricultural Machinery Standard Inspection Conference for Eight Items, Including Internal Combustion Engine Piston Ring Technical Condition was Held in Hangzhou City"

SOURCE: Shanghai NEIRANJI GONGCHENG [CHINESE INTERNAL COMBUSTION ENGINE ENGINEERING] in Chinese No 4, 15 Dec 81 p 31

ABSTRACT: In accordance with the 1981 standardization work plan of the National Bureau of Standards and the Ministry of Agricultural Machinery, a conference was arranged and held on 7-13 Sep 81 in Hangzhou City to formulate the national standard and the Ministry of Agricultural Machinery Standard for internal combustion engine piston, aluminium piston, cylinder cover, main axial and connecting rod bushing, connecting rod screw, connecting rod nut, and timing gear. Participants included 73 delegates representing the National Bureau of Standards, Ministry of Agricultural Machinery, Ministry of Transportation, Zhejiang Provincial Bureau of Agricultural Machinery, Hangzhou City Bureau of Machinery, and some assembly plants, research institutes, parts companies, and transportation companies. The delegates listened to the reports of those who prepared the draft, explaining the process of formulating the major technical indices and the condition of testing and verification work. The wording of the standard for each item was analyzed and compared, and similar standards of foreign countries were cited as a reference.

AUTHOR: HOU Tianli [0230 1131 3810]

ORG: None

TITLE: "Zhejiang Province Called an Internal Combustion Engine Energy Conservation Conference"

SOURCE: Shanghai NEIRANJI GONGCHENG [CHINESE INTERNAL COMBUSTION ENGINE ENGINEERING] in Chinese No 4, 15 Dec 81 p 58

ABSTRACT: On 13-16 Oct 81, the Zhejiang Provincial Agricultural Machinery Society and the Provincial Bureau of Agricultural Machinery called a joint conference to discuss internal combustion engine energy conservation and to exchange experience. The conference was held in Xinchang Diesel Engine Plant; 83 delegates representing related schools of higher education, scientific research organizations, internal combustion engine and parts producing plants, and agricultural machinery and fuel management departments in the province. The deputy secretary of the society spoke on the energy supply situation of China and Zhejiang Province and clarified the fact that fuel conservation in internal combustion engines is especially important for Zhejiang Province which has no petroleum or coal. Special reports on fuel conservation were delivered by 13 delegates; the current oil saving experiences in Zhejiang Province were discussed and summarized. An associate professor of Zhejiang University reported the condition of the conference for establishing the Chinese Internal Combustion Engine Engineering Society. Some members of that society were invited to the conference to make special reports on "Research and Manufacture of the ZH1100W Single Cylinder Diesel Engine," and "Fuel Consumption Level and Fuel Saving Measures of Modern Medium and Small power Diesel Engines."

AUTHOR: ZHOU Nanqi [0719 0589 2630]

ORG: None

TITLE: "Shanghai Municipal Agricultural Machinery Society Held Its First Annual Conference"

SOURCE: Shanghai NEIRANJI GONGCHENG [CHINESE INTERNAL COMBUSTION ENGINE ENGINEERING] in Chinese No 4, 15 Dec 81 p 70

ABSTRACT: The First Annual Conference of the Shanghai Municipal Agricultural Machinery Society was held in the Shanghai Science Hall on 12-13 Oct 81. A total of 377 persons attended and of these 322 persons were members of the society. Reporters of RENMIN RIBAO and JIEFANG RIBAO were invited. The conference received 61 papers and 16 of these concerned the motive power aspect. Through democratic secret balloting, the 35 new members were elected to the board of directors. These newly elected members included old specialists who had worked in the field of agricultural machinery for tens of years as well as some young persons who had just started to work in the field.

6168

CSO: 4009/370

Engineering

AUTHOR: GAO Jinchang [7559 4244 2545]  
YANG Yajun [2799 1246 0689]  
ZHOU Chunhui [0719 2504 2547]

ORG: All of Zhejiang University

TITLE: "Control Scheme for Distillation Column and Energy Consumption"

SOURCE: Shenyang XINXI YU KONGZHI [INFORMATION AND CONTROL] in Chinese No 2, 1982  
pp 12-19

TEXT OF ENGLISH ABSTRACT: This paper, using new distillation column energy consumption formulas and characteristic diagram, discusses and evaluates several ordinary control schemes from both steady state and dynamic energy consumption points of view. Through experimental studies and digital simulation, we have fully proved that our method is very useful in the evaluation and development of energy saving control schemes for distillation columns.

AUTHOR: FANG Xiong [2455 3574]

ORG: Shanghai Public Utilities Research Institute

TITLE: "A New Approach to Synchronization in Telemetric Systems"

SOURCE: Shenyang XINXI YU KONGZHI [INFORMATION AND CONTROL] in Chinese No 2, 1982  
pp 20-27

TEXT OF ENGLISH ABSTRACT: In order to accomplish bit synchronization, the conventional technique in telemetric systems is to use the same frame synchronization codes derived from the control station. But this is not an ideal technique in practice. After a comparison of several typical design ideas, it is concluded that a better choice is the method of "frame information carried by synchronization codes with information codes carrying bit information," which has been practiced in the Intel 8273 HDLC/SDLC controller as a typical example.

However, NRZ<sub>1</sub> codes used in the 8273 controller have some inherent drawbacks in carrying bit information. In our approach, instead of the NRZ<sub>1</sub> code system we have used the Miller Code System, the full advantage of which has long been enjoyed in magnetic recording techniques.

[Continuation of XINXI YU KONGZHI No 2, 1982 pp 20-27]

The author has designed the encoding and decoding logic in terms of the Miller Code System. The resulting circuitry is quite simple and those drawbacks inherent in the 8273 controller have been eliminated. It seems that this new approach will also be advantageous to similar designs other than those in telemetric systems.

AUTHOR: Bu Zixiang [2975 1311 4382]

ORG: Shanghai Chemical Fiber Plant No 5

TITLE: "Coal Economization and Automatic Control of Industrial Boiler Burning Processes"

SOURCE: Shenyang XINXI YU KONGZHI [INFORMATION AND CONTROL] in Chinese No 2, 1982 pp 56-59

TEXT OF ENGLISH ABSTRACT: Based on an analysis of  $\alpha$  control and dynamic match, this paper reveals the mechanism of coal economization in automatic control of boiler burning processes. Several actual examples are described that have already reaped economic advantage, and the current state of coal economization in automation of industrial coal burning boilers is reviewed.

9717

CSO: 4009/344

AUTHOR: XIA Zenglu [1115 1073 4389]

ORG: Research Institute of Geography, Chinese Academy of Sciences

TITLE: "Characteristics of Cadmium Pollution, Its Regional Balance, Environmental Capacity, and Prevention in the Southeast Suburbs of Beijing"

SOURCE: Beijing HUANJING KEXUE [JOURNAL OF ENVIRONMENT SCIENCE] in Chinese Vol 3 No 2, 30 Apr 82 pp 14-18

ABSTRACT: The southeastern suburbs of Beijing are located on the middle and lower parts of the Yongding River alluvial fan. The topography is flat and the Quaternary deposit is thick, mostly in the 60-200 m range. The ground water belongs to the pressure bearing type, but is rather shallow, mostly at about 1-2 m. The annual mean rainfall is 600mm, mostly in the summer. During the dry and windy winter and spring, the evaporation is tremendous. In the region, 470 thousand mu of fields are irrigated with wastewater for as long as 7-15 years. After the wastewater is treated, the sludge is used as fertilizer. Cadmium contamination originates mainly from industrial discharge, about 650 kg/year, with some (about 131 kg) from fuel coal of the upper reaches. The cadmium content of the surface water is mostly below 1ppb (the standard is 10ppb.) Due to the fact that the water output is greater than the input, the regional cadmium accumulation also includes the portion in the input water, estimated at 30 percent of the total annual accumulation. After the horizontal and vertical distribution of Cd in the soil of the region is com-

[continuation of HUANJING KEXUE Vol 3 No 2, 1982 pp 14-18]

puted, the paper states that the current accumulation of 393 kg in the region is about 25 percent of the maximum permissible capacity and in another 35 years, the maximum for the use of wastewater and sludge will be reached. For prevention of further contamination, the paper suggests that: (1) The sludge should not be applied as fertilizer and should be further treated (such as burned) ; of course, this process will mean waste of energy and fertilizer as well as atmospheric pollution. (2) The sludge should be transferred to other remote regions to be used as fertilizer, but no more than 1,000 jin/mu should be applied. (3) Adding suitable quantities of nitrogen, phosphorus, and potassium to the sludge at the treatment plant to be sold nationwide as a fertilizer. (4) The Beijing Chemical Plant discharges 65 percent of the total Cd in the region; if this discharge is treated at the plant, the sludge of the Gaobeidian Wastewater Treatment Plant will be safe as a fertilizer.

AUTHOR: HOU Shaofan [0230 1421 5400]  
ZHU Zhenyuan [2612 2182 3293]

ORG: Both of Research Institute of Geography, Chinese Academy of Sciences

TITLE: "Low Selenium Environment and Vitamin E in Human Serum Relative to the Kaschin-Beck's Disease"

SOURCE: Beijing HUANJING KEXUE [JOURNAL OF ENVIRONMENT SCIENCE] in Chinese Vol 3 No 2, 30 Apr 82 pp 18-23

ABSTRACT: In China, endemic regions of Kaschin-Beck's disease, Keshan disease, and animal white muscle disease basically overlap, mainly the transitional area between the moist Southeast and the arid Northwest. Tests conducted by the authors reveal that the selenium content of major soils of the regions affected by the diseases is 0.088-0.360 ppm, that of the grains below 20-30 ppb. Of the inhabitants, 94 percent have serum selenium content below 0.031  $\mu\text{g}/\text{l}$  and the selenium content of the hair of inhabitants is 100-200 ppb. From Jul 79 to Jun 80, the authors treated 41 cases of Kaschin-Beck's disease with sodium selenite- $\text{V}_{\text{E}}$  and 36 of them recovered from the disease. Based upon these data, the authors believe that environmental selenium deficiency of these regions is perhaps the cause of the low level selenium nutrition of the inhabitants. The low level selenium nutrition in turn leads to a reduction of certain enzymic activity to cause the Kaschin-Beck's disease, as well as the Keshan disease and the animal white muscle disease.

AUTHOR: XU Fang [1776 2455]  
JIN Yinlong [6855 6895 7893]  
ZHANG Quanzeng [1728 0356 1073]  
YIN Chunfu [1438 2504 7683]  
ZHU Yuling [2612 3768 3781]

ORG: XU, JIN, ZHANG, YIN of Research Institute of Hygiene, Chinese Academy of Medical Sciences; ZHU of Shandong Provincial Public Health and Epidemic Prevention Station

TITLE: "Chromosome Aberration Within Lymphocytes of Fishermen on the Hong Island"

SOURCE: Beijing HUANJING KEXUE [JOURNAL OF ENVIRONMENT SCIENCE] in Chinese Vol 3 No 2, 30 Apr 82 pp 28-30

ABSTRACT: Intravenous blood and hair samples of 41 healthy fishermen on Hong Island in Jiaozhou Bay and a control group of 28 workers of nearby factories and a hospital are taken to compare the incidence of chromosome aberration and the mercury content of hair. The incidence of chromosome aberration of the fishermen and that of the control is 0.69 and 0.66 percent respectively, a difference not statistically significant. The mercury content of the hair of the 2 groups is 1.181 ppm and 0.608 ppm, obviously statistically significant. The fishermen eat 6-22 jin/month of seafood and the control group only 2-3 jin/month. Analyses of the seafood fail to reveal exceedingly high mercury content, however. The sea of Jiaozhou Bay is relatively severely contaminated by mercury, cadmium, arsenic, and crude oil.

AUTHOR: JIANG Meizhen [5592 5019 3791]  
LIU Jiarong [0491 0857 5554]

ORG: Both of Hangzhou Botanical Garden

TITLE: "Purification of Sulfur Dioxide in the Atmosphere Around the West Lake of Hangzhou"

SOURCE: Beijing HUANJING KEXUE [JOURNAL OF ENVIRONMENT SCIENCE] in Chinese Vol 3 No 2, 30 Apr 82 pp 31-33

ABSTRACT: In the area surrounding the West Lake, there are 3,389 mu of parks and 60,189 mu of forests. The vegetative coverage is above 70 percent. Industries have developed very rapidly in nearby Hangzhou City in recent years and surveys indicate 27 types of atmospheric pollutants, with SO<sub>2</sub> the most serious. Samples of plants were taken to study the effect of the atmospheric SO<sub>2</sub> on them and their purification effect on the pollutant. The sulfur content of the leaf-samples was found to vary with the season, reaching a peak in Jan-Mar, at 2,655-4,605 mg/g. Artificial fumigation experiment indicated that most of the plants of the region are resistant to SO<sub>2</sub>. Of the 137 tree species tested, 82 species are highly resistant, 40 medium, and 15 weak.

AUTHOR: LIN Hanzong [2651 3352 1350]

ORG: Research Institute of Hygiene, Chinese Academy of Medical Sciences

TITLE: "An Investigation of the Relationship Between Dietary Intake and The Metal Content of Hair and Urine of Fishmen"

SOURCE: Beijing HUANJING KEXUE [JOURNAL OF ENVIRONMENT SCIENCE] in Chinese Vol 3 No 2, 30 Apr 82 pp 65-68, 33

ABSTRACT: For the purpose of understanding the effect of ocean pollution on human health, an investigation into the heavy metal content of food, hair, and urine of 2 groups of fishermen, 61 in Hongdao and 60 in Zhangzidao, both islands in Jiaozhou Bay, 10 nautical miles from Qingdao. Test results indicate the metal intake of the fishermen is, on the average, 0.015-0.029mg of mercury, 0.047-0.025 mg of lead, 0.056-0.005 mg of cadmium, and 0.29-0.21 mg of arsenic per person per day. The metal content of their hair is 1.60-2.10 μg/g of mercury, 9.49-2.27 μg/g of lead, 0.20-0.05 μg/g of cadmium. The metal content of their urine is 0.0009 and 0.0017 mg/l of mercury and 0.16-0.12 mg/l of arsenic. The above findings indicate that the contents of metals in the fishermen's hair and urine do not exceed the normal of domestic or foreign reports.

AUTHOR: WANG Da [3769 6671]  
WANG Hengwen [3769 5683 2429]

ORG: Both of Shanghai Research Institute of Cytobiology, Chinese Academy of Sciences

TITLE: "Some Methodological Problems in Environmental Toxicology Research"

SOURCE: Beijing HUANJING KEXUE [JOURNAL OF ENVIRONMENT SCIENCE] in Chinese Vol 3 No 2, 30 Apr 82 pp 73-76

ABSTRACT: All the factories of Shanghai have good labor protection systems. The cause of death of all workers is clearly recorded and the hospitals have complete case histories of cancer survivors. In the course of the 1970 cancer survey, the authors discovered, however, the recorded data are only limitedly reliable. The problems are as follows: (1) The size, the number of workers, and the length of establishment of the factories vary too much for statistical processing; (2) The products and work procedures of some factories have changed frequently and many workers have changed their occupation or been transferred; (3) Some data are incomplete and some diagnoses not dependable. Problems regarding environmental pollution inspection and animal experiments are also discussed.

6248

CSO: 4009/343

Heat Treatment

AUTHOR: YU Zhiqin [0060 1807 0530]  
FANG Weijie [2075 3634 2212]

ORG: YU of Changchun Optical Machinery Institute, Chinese Academy of Sciences;  
FANG of Jilin Provincial Research Institute of Machine Industry Design

TITLE: "Present Condition and Future Prospect of Laser Devices and Laser Heat Treatment"

SOURCE: Beijing JINSHU RECHULI [HEAT TREATMENT OF METALS] in Chinese No 6,  
25 Jun 82 pp 1-6

ABSTRACT: Laser scientists and heat treatment scientists are cooperating very closely in China to carry out extensive and profound research on laser surface treatment technology. At present, the technique of laser surface phase conversion hardening heat treatment is the relatively better grasped one and very actively applied to cast iron surface treatment in the automobile manufacturing industry in China. In the future, medium power (1-5 kw) CO<sub>2</sub> laser devices should become commercialized and large power CO<sub>2</sub> laser devices (5-20 kw) should be developed especially in terms of resolving the problems of useful life and reliability. With the development of industrial use CO<sub>2</sub> laser devices, applications of laser surface treatment in industrial production will undoubtedly increase. The types and characteristics of laser devices and problems of optics in laser heat treatment are introduced. Extensive research is being carried out on the size and depth of focus, the scanning speed, the width and depth of the hardened zone, the productivity, the hardness distribution, and the surface darkening treatment etc. especially on the interrelationship of

[continuation of JINSHU RECHULI No 6, 1982 pp 1-6]

these parameters. The authors have conducted some research on the phase conversion hardening of cast iron and some major types of steel but more studies are needed. Attention should especially be given to laser amorphization but this will mainly depend upon progress in the development of high power laser devices and certain special alloys. Tools for laser heat treatment, especially the laser device, require a great deal of investment and their transportation and maintenance are also costly. The establishment of laser heat treatment centers for national and/or regional use to improve their rate of utilization is suggested. Moreover, it is also suggested that only those parts of very complicated shapes, requiring the deformation to be very little, and impossible to be treated otherwise should be included for laser heat treatment and of course only if the property of such parts is to be extremely obviously improved after laser heat treatment.

AUTHOR: None

ORG: The Secretariat, Chinese Society of Mechanical Engineering Heat Treatment Society

TITLE: "Conference News"

SOURCE: Beijing JINSHU RECHULI [HEAT TREATMENT OF METALS] in Chinese No 6, 25 Jun 82 pp 64- inside back cover

ABSTRACT: On 9-11 Apr 82, the Chinese Mechanical Engineering Heat Treatment Society held its Fourth Expanded Conference of the Board of Directors and 34 current directors and 21 alternates attended. The essential condition of work of the society since the Third Conference held in Aug 80 was reported by the deputy directors and the general condition of the First International Materials Heat Treatment Conference held in Oct 81 in which the delegation representing the Chinese Heat Treatment Society participated was reported by the chief secretary of the society. The deputy secretary also summarized for the conference the progress of the work of preparing for the Third International Materials Heat Treatment Conference to be held in Shanghai in 1983. Those responsible for the various study groups also reported their respective activities in the past year. Following some enthusiastic discussions, the conference resolved, among other items, that: (1) The Third National Heat Treatment Conference is to be held in Xi'an City in early Nov 82 and about 80 papers are to be selected for discussion; (2) Based upon the International Materials Heat Treatment Joint Board of Directors' suggestion, the papers to be submitted by

[continuation of JINSHU RECHULI No 6, 1982 pp 64 - inside back cover]

China to the Conference to be held in Shanghai will be on 8 specific subjects. They will be selected principally from the papers submitted to the annual national conference. (3) In the future, JINSHU RECHULI XUEBAO will publish chiefly theoretical papers while JINSHU RECHULI will emphasize papers closely related to production practice. It is hoped that the quality of the latter will continue to improve to resolve some problems of actual production through discussion. (4) A series of books on heat treatment are to be published and an editorial committee of 16 members is established for that purpose. (5) With the cooperation of Beijing Science Education Motion Picture Plant, a motion picture introducing the condition and achievements in heat treatment in ancient and present China is to be prepared. (6) The next conference of the board of directors is to be held in Xi'an in Nov 82 just before or after the annual conference of the society.

6248

CSO: 4009/364

AUTHOR: TAN Zugen [6223 4371 2704]

ORG: Zhejiang University

TITLE: "Some Views on the Development of Transducers in China"

SOURCE: Xi'an GONGYE YIBIAO YU ZIDONGHUA ZHUANGZHI [INDUSTRIAL INSTRUMENTATION AND AUTOMATION] in Chinese No 2, 5 Apr 82 pp 5-6

ABSTRACT: A transducer converts one form of energy to another and its precision affects the accuracy, stability, and reliability of a meter no matter how excellent are the other parts of the instrument. The research and production of transducers have had some progress in China in recent years but they remain few in quantity, incomplete in types, and poor in quality. This paper discusses mainly the importance of transducers and reports the measures taken in foreign countries, especially England, to guarantee the quality of transducers and inspect them with special instruments. In China, the properties of some transducers are usually emphasized during their experimental manufacturing stage, but when they are being produced in small batches, attention is generally not given to the work procedures which influence the stability and reliability of the transducers. Their initial property indices are usually satisfactory, but after they have been used for a period of time, their properties often deteriorate with time. The author suggests that if every work procedure is emphasized, the quality of the Chinese-made transducers should improve. The author also believes that it is necessary to carry out research and make new types of transducers in China, especially to meet the needs for developing large scale integrated circuits.

6248

CSO: 4009/369

Machine Tools

AUTHOR: LU Qingxiong [4151 1987 3574]  
WANG Guojun [3769 0948 6874]  
HU Bingwen [5170 4426 2429]

ORG: All of Jilin Industrial University

TITLE: "Present Situation and Future Prospect of Automation in Machining Process in China"

SOURCE: Dalian ZUHE JICHUANG [MODULAR MACHINE TOOL] in Chinese No 6, 25 Jun 82 pp 30-34

ABSTRACT: Some statistical data regarding the present condition of automated machining are reported. For example, modular machine tools are used in 61.2 percent of the automated machining lines. In terms of parts, 31.6 percent of steel parts, 61.7 of cast iron, and 6.7 of colored metals are machined on automated lines. In automatic measurement, there are 29 automated lines in the agricultural machinery system, among others, but in most cases the work condition remains less than satisfactory. In automatic compensation, some work has begun in Dalian Modular Machine Tool Research Institute of the Ministry of Machines No 1, the Third Academy of the Ministry of Agricultural Machinery, etc. but in all cases, the work is still in the experimental stage. In digital and group control, the problem is primarily the high cost of manufacturing. Stability and reliability of the more complex digital control machines also present some problems. In group control, according to the survey of the authors, some 10+ organizations, including Shanghai Machine Tool Electrical Instrument Plant No 2, Shenyang Air-blower Plant (using an imported IBM-370 computer), etc. have

[continuation of ZUHE JICHUANG No 6, 1982 pp 30-34]

adopted it and in general, the product quality is stable and the work efficiency has been raised 5-6 fold. The second part of the paper devotes to a discussion of the future prospect of automation in machining in China. Although the major direction of development is toward high precision, high efficiency, and automation to guarantee the quality of products, to improve the labor condition, to raise the labor productivity, and to gain a greater economic benefit, during the current stage of readjustment of the national economy, China's foundation of automation is poor and problems are numerous. The potential is endless, but in terms of offering highly automated equipment for manufacturing in the textile industry, hardware and electrical appliances, and agricultural machinery, the prospect is very good because of the very large sales market, but the technology of automation in China is still relatively backward, especially in the aspect of electrical automatic control. At present, it is still primarily a relay control device. Further advancement depends upon improved mastery of the electronic technology.

6248

CSO: 4009/365

Metrology

AUTHOR: ZHENG Zuyao [6774 4371 1031]  
WANG Fengcheng [3769 7364 6134]

ORG: None

TITLE: "Standard Mercury Thermometer for 300-500°C"

SOURCE: Beijing JILIANG XUEBAO [ACTA METROLOGICA SINICA] in Chinese No 3, 22 Jul 82 p 240

ABSTRACT: Beijing Research Institute of Glass was given the responsibility of making the standard 300-500°C thermometer; the Chinese Academy of Metrology and the Beijing Municipal Research Institute of Metrology participated in the task of carrying out the research. The product has been approved by the National Certification Conference in Sep and been given to Beijing Research Institute of Glass to put into production. Different grade of glass materials must be used to make this type of mercury thermometer depending upon the different range of temperature it is to be used to measure. Some artificial aging treatment process is also necessary. The research and manufacture of this type of mercury thermometers had never before been done in China. A blank is therefore filled by this product. It is composed of 4 branches: the temperature measurement interval of each branch is 50°C; there is a zero place marker. The certification document indicates that the error rate is  $\pm (0.10 - 0.20)^\circ\text{C}$ . The major technical parameters of the thermometer are included in the paper.

6168

CSO: 4009/374

Vacuums

AUTHOR: LI Zhongmin [2621 1813 3046]

ORG: Motor Division, Liming Machinery Company, Shenyang

TITLE: "Research to Make China's First Medical Use Cast Titanium Vacuum Furnace Has Succeeded"

SOURCE: Shenyang ZHENKONG [VACUUM] in Chinese No 3, 25 Jun 82 pp 1-4

ABSTRACT: Medical scientists in China are giving a great deal of attention to the technique of using titanium or titanium alloy as replacement for human skeletal bones. The Shenyang Troop General Hospital has applied it in its Stomatology and other clinical departments and produced satisfactory results. To process titanium into a shape of a bone needed by a patient is as time consuming as carving it out of jade, however. Some hospitals have tried to forge or machine tooling titanium bones but the production efficiency is very low. It is very wasteful to use a large capacity furnace to make a bone weighing less than one kg. These are very difficult problems in applying the technique. In 1978, the Shenyang Troop General Hospital and Liming Machinery Company jointly accepted the job of making a special vacuum furnace for just this purpose. After 3 years of research, on 16 Apr 81, some artificial bones, including the femur, the mandible, the skull bones, teeth, and lower limbs and joints, were successfully cast-produced for the first time. Of these, the joint bone has been applied

[continuation of ZHENKING No 3, 1982 pp 1-4]

to a patient on 12 May 81. Photos are included in the paper to illustrate this fact. The work principle of the vacuum furnace is introduced.

AUTHOR: ZHAO Chengxiu [6392 2052 0208]

ORG: Shenyang Research Institute of Vacuum Technology

TITLE: "Roots Blower Pumps Should be Extensively Developed in China"

SOURCE: Shenyang ZHENKONG [VACUUM] in Chinese No 3, 25 Jun 82 pp 45-47

ABSTRACT: Advantages of roots blower pumps, including obvious energy saving effects, low oil steam back-flow, realization of  $10^{-1}$  -  $10^{-8}$  exhaust and free of oil pollution, etc. are introduced, citing unnamed Japanese journals and literature provided by the Hibon Company of France. Some information regarding the condition of development of roots blower pumps in foreign countries is available in a book, ZHENKONG GONGYE, published by the Information Center of the Ministry of Machines No 1 and the paper briefly mentions its growing application in such developed countries as the USA, Japan, France, and Italy, in the 70's. In China, with the introduction of unified designing, standard, and work procedure among the vacuum industries, the product quality has been improved a great deal in the past few years and some of the products have entered the export market in small quantities. In general, the level of the vacuum technology is still not high and the development of the various types of pumps uneven. The condition of development of the roots blower pump remains the same as the description in the 1974 paper (ZHENKONG JISHU BAODAO No 3, 74 p 12). There are complaints about the sharp noise of Chinese-make roots blower pumps

[continuation of ZHENKONG No 3, 1982 pp 45-47]

and the vacuum seal leaking very easily. Some people think it is risky to use them inspite of their acknowledged advantages over other types of pumps. These 2 problems undoubtedly must be resolved before the application of roots blower pumps may be extended in China. The author suggests that for the purpose of satisfying the development needs of the national economy, efforts should be quickly organized for cooperative research and development in roots blower pump to resolve these existing problems.

AUTHOR: None

ORG: Information Office, Shenyang Research Institute of Vacuum Technology

TITLE: "The Second Work Conference of the Vacuum Equipment Industry Information Network Was Held in Shantou"

SOURCE: Shenyang ZHENKONG [VACUUM] in Chinese No 3, 25 Jun 82 back cover

ABSTRACT: The Second Work Conference of the Vacuum Equipment Industry Information Network was organized under the guidance and support of the Information Centers of the General Bureau of General Purpose Machines of the Ministry of Machines No 1, the Shantou Municipal Bureau of Machine Industry No 1, and the Shantou Vacuum Machinery Plant and held in Shantou on 11 - 15 Apr 82; 23 persons representing 15 organizations attended. The work of the information network in the past year was summarized to affirm positive achievements and to find the shortfalls. The work plan for 1982-83 was discussed and formulated. Comrades of the Information Center of the Ministry of Machines No 1 brought many models and materials from Beijing to exhibit at the conference and the delegates were very impressed. The paper does not mention any special subject or special type of information concerning any vacuum technology having been discussed at the conference. The paper mentions speeches and reports delivered by this and that person but not the nature or the content of these reports.

6248

CSO: 4009/363

Weights, Measures

AUTHOR: GUO Hualin [6751 5478 2651]

ORG: Guilin Measuring and Cutting Equipment Plant Research Institute

TITLE: "Adjustment, Repair, and Inspection of the QP373 Transmission Testing Device"

SOURCE: Beijing JILIANG JISHU [MEASUREMENT TECHNIQUE] in Chinese No 4, 18 Jul 82  
pp 31-33

ABSTRACT: The QP373 is a special instrument used for research, manufacture, installation, maintenance, and repair of carrier wave equipment of long distance telecommunication. The author has had some experience in adjusting, repairing, and inspecting the type of instrument like the QP373. The paper includes a table listing 6 types of possible problems with this instrument: (1) The indicator light is out so that there is no way for the instrument to display the result of measurement; (2) The indicator light is on but there is no indication for correction I, II, wide band, and frequency-selective device measurement; (3) Correction I, II are normal, but there is no indication for wide band and frequency-selective device; (4) No indication for normal, correction I, II; (5) Indicator either continues to swing or gives no indication for frequency-selective device correction II and frequency-selective measurement; (6) Accurate wide band measurement, but frequency-selective measurement is too high. The 5th type trouble occurs especially easily in the damp season in South China. The method of adjusting, repairing, or correcting the instrument to overcome each of these problems is detailed.

AUTHOR: LI Yuzhi [2621 3768 2535]

ORG: None

TITLE: "National Standard Examination Conference Approved the Aluminium Alloy Hardness and Strength Conversion Value"

SOURCE: Beijing JILIANG JISHU [MEASUREMENT TECHNIQUE] in Chinese No 4, 18 Jul 82  
p 56

ABSTRACT: Following more than 7 years of research work, and collecting nearly 80 thousand test data and verification data, China's own standard of "Aluminium Alloy Hardness and Strength Conversion Value" has recently been approved and put in force officially as the national standard. The National Standard Examination Conference regards it as a breakthrough in scientific research as well as technological application. A blank in China's basic standards is thus filled. This research result is a product of cooperation of the 8 organizations of China Academy of Metrology, Beijing Research Institute of Aviation, the 304 Institute of the Ministry of Machines No 3, the Civil Aviation Beijing Maintenance and Repair Base, and the Northeast Light Alloy Processing Plant. Besides, several tens of engineers belonging to 18 scientific research and production organizations also took on portions of the task.

6168

GSO: 4009/371

END