

JPRS-CST-91-013
20 JUNE 1991

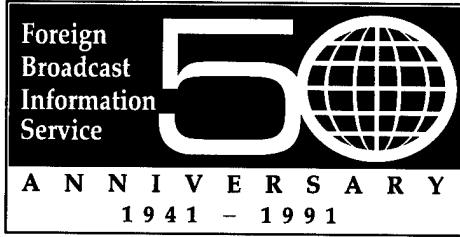

19981210 052

JPRS Report

Science & Technology

China

DTIC QUALITY INSPECTED 3

REPRODUCED BY
U.S. DEPARTMENT OF COMMERCE
NATIONAL TECHNICAL INFORMATION SERVICE
SPRINGFIELD, VA. 22161

Science & Technology China

JPRS-CST-91-013

CONTENTS

20 June 1991

DEFENSE R&D

- Domestic IR-Imaging Precision-Guidance Technology Viewed
[Li Qunzhang; SHIJIE DAODAN YU HANGTIAN, Feb 91] 1

BIOTECHNOLOGY

- Polyvalent Antiserum Eliminates Trace Phospholipase A₂ From Membrane Toxins of *Naja naja atra*
[Zou Zhiyang, et al.; SHENGWUHUAXUE YU SHENGWUWULI XUEBAO, No 2, Mar 91] 2
- Expression of the Gene Encoding K88ac Antigen of Porcine Enterotoxigenic *Escherichia coli*
[Wu Yaxu, Shi Chenghua, et al.; SHENGWU GONGCHENG XUEBAO, No 1, Feb 91] 2
- Study on Rat-Rat Hybridoma Technique and Production of Rat Monoclonal Antibodies Against HIV
and HBsAg [Fang Jiachun, et al.; SHENGWU GONGCHENG XUEBAO, No 1, Feb 91] 2
- Technology of the Production of the Protein Antigens of K88, K99 Diarrhea Vaccine
[Gu Danian, et al.; SHENGWU GONGCHENG XUEBAO, No 1, Feb 91] 2
- Insect Resistance of Transgenic Tobacco Plants Expressing δ -Endotoxin Gene of *Bacillus thuringiensis*
[Tian Yingchuan, Qin Xiaofeng, et al.; SHENGWU GONGCHENG XUEBAO, No 1, Feb 91] 2
- Subcloning and Expression of δ -Endotoxin Gene and Its 3' End Deletion of *Bacillus thuringiensis* in
Escherichia coli and *Agrobacterium tumefaciens*
[Guo Sandui, Chen Xuejuen, et al.; SHENGWU GONGCHENG XUEBAO, No 1, Feb 91] 3
- Cloning of DNA Fragments With Promoter Function From Temperate Phage of *Bacillus licheniformis*
[Sheng Xiaoyu, Li Yuyan; SHENGWU GONGCHENG XUEBAO, No 1, Feb 91] 3
- Expression of Hepatitis B Virus Surface Antigen Gene in Insect Baculovirus Vector Systems
[Long Qingxin, Su Deming, et al.; SHENGWU GONGCHENG XUEBAO, No 1, Feb 91] 3
- Gene Cloning and Expression of Propionyl Acylase of *Streptomyces mycarofaciens* Mutant
[Li Yuan, Sun Yaping, et al.; SHENGWU GONGCHENG XUEBAO, No 1, Feb 91] 3

COMPUTERS

- Reports on New Software Products, Sino-Japanese Joint Venture 4
- Aerospace Industry Engineering Software [Wang Xiren; JISUANJI SHIJIE, 13 Mar 91] 4
- Software Engineering Tool Set [Chen Chunmei; JISUANJI SHIJIE, 27 Mar 91] 4
- Sino-Japanese Software Joint Venture [Gao Yuqian; JISUANJI SHIJIE, 3 Apr 91] 4
- Reports on Computer Network Standards, Technologies 4
- First Domestically Developed OSI Prototype System [Liu Jiuru; JISUANJI SHIJIE, 30 Jan 91] .. 4
- Domestically Developed ISDN Model Passes Appraisal
 [Ji Hongguang, et al.; KEJI RIBAO, 19 Mar 91] 5
- MAN Heterogeneous-Computer Interconnection, TOP/FTAM Software
 [Gao Lihua; JISUANJI SHIJIE, 3 Apr 91] 5
- High-Speed Composite Computer LAN Built [Wang Qing; KEJI RIBAO, 22 Apr 91] 5
- Reports on Optical Disk, Winchester Disk, Floppy Disk Technologies 6
- 5.25-Inch Erasable Magneto-Optical Disk Passes Appraisal
 [Pan Ye, Huang Xin; ZHONGGUO DIANZI BAO, 3 Mar 91] 6
- 200-mm Erasable Phase-Change Optical Disk Developed [Liu Dong; KEJI RIBAO, 6 Mar 91] 6
- More on 200-mm Phase-Change Disk [Wang Yingde; JISUANJI SHIJIE, 3 Apr 91] 6
- 135 TPI 3.5-Inch Floppy Disk Head Developed [Lu Xiaoge; JISUANJI SHIJIE, 3 Apr 91] 6
- 170MB 5.25-Inch Winchester Disk Drive Developed
 [Zhang Tianyi; JISUANJI SHIJIE, 6 Mar 91] 6
- 3.5-Inch 20MB Winchester Disk Trial Manufactured [Lin Jian; JISUANJI SHIJIE, 6 Mar 91] 7
- 600MB Optical Disk Drive Passes Appraisal [Chang Ming; JISUANJI SHIJIE, 27 Mar 91] 7
- 5.25-Inch Half-Height 80MB Winchester Disk Drive, Controller Accredited
 [Huang Xuchen; JISUANJI SHIJIE, 27 Mar 91] 7
- 3.5-Inch 4MB Floppy Disk Drive Developed [Feng Peixian; JISUANJI SHIJIE, 27 Mar 91] 7
- 3.5-Inch 40MB Winchester Disk Drive Developed
 [Tian Feng, Yu Bin; ZHONGGUO DIANZI BAO, 21 Apr 91] 7

LASERS, SENSORS, OPTICS

Six Types of Optical Logic Gates Realized With Hybrid Optically Bistable Laser Diodes
[Shi Jiawei, Jin Enshun; BANDAOTI XUEBAO, Apr 91] 8

Experimental Research on 'Dual-Target Butt Joint' Ne-Like Ge High-Gain Soft X-Ray Laser
[Wang Shiji, Gu Yuan, et al.; ZHONGGUO KEXUE, Feb 91] 9

Tangible Results Realized From Superlattice & Optoelectronics Research
[Fan Jian; KEJI RIBAO, 9 Apr 91] 10

MICROELECTRONICS

New OEICs Developed [Huang Xin; ZHONGGUO KEXUE BAO, 26 Feb 91] 12

Quantum-Well Laser Diodes, Quantum-Well SEED Developed [Fan Jian; KEJI RIBAO, 28 Feb 91] ... 12

Semi-Insulating GaAs Monocrystal Developed for High-Speed ICs
[Liu Yali and Ji Hongguang; KEJI RIBAO, 4 Mar 91] 12

ASIC-Based Intelligent Logic Design System Developed
[Xue Wu and Jian Zhong; ZHONGGUO DIANZI BAO, 8 Mar 91] 13

Mask-Alignment Exposure Machine, MOCVD Equipment, Chip-Carrier Sintering Station Developed
[Wang Changhe; ZHONGGUO DIANZI BAO, 10 Mar 91] 13

ICCAD/ICCAT/ICCAM System Developed
[Li Qiongrui and Jie Yannan; ZHONGGUO DIANZI BAO, 10 Mar 91] 14

1.5-Micron VLSI Technology, 1 Mbit Chinese-Character ROM Pass Acceptance Check
[Jie Yannan; ZHONGGUO DIANZI BAO, 13 Mar 91] 14

GaAs Microwave Power FETs, Other Devices from Institute 13 Pass Appraisal
[Liu Dong; ZHONGGUO DIANZI BAO, 15 Mar 91] 15

Six New ICs Developed by Institute 24 [Cai Shiwei; ZHONGGUO DIANZI BAO, 15 Mar 91] 15

VLSI-Oriented Rapid Heat Treatment Equipment Developed
[Jie Yannan and Liang Shu; ZHONGGUO DIANZI BAO, 17 Mar 91] 15

ASIC-Oriented 3-Micron CMOS Fabrication Technology Studied
[Huang Xin; ZHONGGUO KEXUE BAO, 19 Mar 91] 16

ASIC-Oriented Si-Gate CMOS Gate-Array Design System Developed, Accredited
[Yue Ziqiang; ZHONGGUO DIANZI BAO, 22 Mar 91] 16

GaAs/AlGaAs Heterojunction HEMT Passes Appraisal
[Tong Lin; ZHONGGUO DIANZI BAO, 24 Mar 91] 16

VLSI High-Density Chip-Carrier Product Series Passes Appraisal
[Liu Changan and Zheng Zhaosen; ZHONGGUO KEXUE BAO, 29 Mar 91] 17

New High-Speed Devices, Optoelectronic-Device Materials Developed
[Fang Shifen; ZHONGGUO DIANZI BAO, 29 Mar 91] 17

32-Bit SPARC-Chip Logic Design Further Described [Xiao Qiang; JISUANJI SHIJI, 3 Apr 91] 17

Near-Resonance Scattering Studies of Longitudinal Optic Phonon Modes in GaAs/AlAs Superlattices
[Wang Zhaoping, Han Hexiang, et al.; BANDAOTI XUEBAO, May 91] 18

Epitaxy of CdTe Single-Crystal Films on GaAs Substrates by ICBE
[Fen Jiayou, Tang Haipeng, et al.; BANDAOTI XUEBAO, May 91] 18

Studies of Reaction Characteristics and Electronic Properties at Cr/GaAs Interfaces
[Jin Gaolong, Chen Weide, et al.; BANDAOTI XUEBAO, May 91] 19

Charge DLTS and Its Application to Deep-Level Measurement of Gallium Arsenide on Silicon
[Dong Qi, Zheng Xinyu, et al.; BANDAOTI XUEBAO, May 91] 19

A New Approach to Hierarchical Floorplanning for Building-Block Layout
[Ying Changsheng, Hong Xianlong, et al.; BANDAOTI XUEBAO, Apr 91] 19

Monte Carlo Modeling of Steady Characteristics for Submicrometer GaAs MESFET
[Zhao Honglin, Li Binqiao, et al.; BANDAOTI XUEBAO, Apr 91] 19

Pressure Behavior of In_xGa_{1-x}As/GaAs Strained Quantum Wells With Different Widths
[Li Guohua, Zheng Baozhen, et al.; BANDAOTI XUEBAO, Mar 91] 19

Study of Modulation Spectrum of Semiconductor Quantum Wells
[Qian Shixiong, Yuan Shu, et al.; BANDAOTI XUEBAO, Mar 91] 20

Investigations on Optical Properties of GaInAs/AlInAs Multiple Quantum Well Heterostructures
[Jiang Desheng, Li Feng, et al.; BANDAOTI XUEBAO, No 3, Mar 91] 20

SUPERCONDUCTIVITY

Status & Future of, Recommendations for Nation's Superconductivity R&D [Han Shuo; XIANDAIHUA, 23 Feb 91]	21
Experimental Observation of V-Sr-Tl-O System With 170K Transition Temperature [Liu Zhiyi, Jia Shunlian, et al.; KEXUE TONGBAO, 1-15 Apr 91]	23
Flux Creep in Sintered Bi(Pb)SrCaCuO Bulk Superconductor [Feng Shangshen, Cao Xiaowen, et al.; DIWEN WULI XUEBAO, No 2, Mar 91]	23
Synthesis, Structure and Properties in (Bi, Pb, Sb)-Sr-Ca-Cu-(O, F) Superconductors [Wu Xiaoling, Gao Xiaohui, et al.; DIWEN WULI XUEBAO, No 2, Mar 91]	24
Effect of Bi/Pb Ratio and Annealing Temperature on $T_{c(R=0)}$ and Formation of High- T_c Phase in Bi-Pb-Sr-Ca-Cu-O System [Xi Zhengping, Ji Chunlin, et al.; DIWEN WULI XUEBAO, No 2, Mar 91]	24
Oxygen Content, Structure and T_c of 110K Single-Phase Bi(Pb)-Sr-Ca-Cu-O Superconductor [Wang Nanlin, Tan Minqiu, et al.; DIWEN WULI XUEBAO, No 2, Mar 91]	24
Investigation, Fabrication of Nb ₃ Sn Magnets in NbTi-Nb ₃ Sn Hybrid Superconducting Magnet System [He Mu, Hu Shanrong, et al.; DIWEN WULI XUEBAO, No 2, Mar 91]	24
Bi(Pb)-Sr-Ca-Cu-O(F) Superconducting Thin Films [Shi Xiangqing, Huang Xiaomei, et al.; DIWEN WULI XUEBAO, No 2, Mar 91]	25

TELECOMMUNICATIONS R&D

Latest Reports on Fiber Optic Communications	26
2-5-Micron-Wavelength HgCdTe Receiver Developed [Yue Ziqiang; ZHONGGUO DIANZI BAO, 3 Mar 91]	26
Tianjin-Tanggu Unrepeated DS4 System Accredited [Wang Xun; ZHONGGUO DIANZI BAO, 29 Mar 91]	26
Domestic Optical Cable Laid Surpasses 12,000 Km Mark [Jing Chaoyu; KEJI RIBAO, 30 Mar 91]	26
First Domestically Made Composite Optical Cable System [Li Dexiang, Xing Chuhua; SHAANXI RIBAO, 2 Apr 91]	26
Domestically Developed DS5 Optical Communications System [You Xin, et al.; KEJI RIBAO, 12 Apr 91]	26
Five Achievements From Beijing P&T Institute Pass Appraisal [Li Jianguo; BEIJING KEJI BAO, 13 Apr 91]	27
High-Speed InGaAsP/InP LED Developed for Broadband Loops [Guo Kangjin, et al.; BANDAOTI XUEBAO, No 5, May 91]	27
Holographic Gratings Fabricated on InGaAsP/InP DFB Lasers [Miao Yubo, et al.; BANDAOTI XUEBAO, No 5, May 91]	28

PHYSICS

Hybrid Fusion-Fission Reactor Project Passes Expert Appraisal [Deng Xianchun; ZHONGGUO KEXUE BAO, 26 Feb 91]	29
---	----

Domestic IR-Imaging Precision-Guidance Technology Viewed

91P60175A Beijing SHIJIE DAODAN YU HANGTIAN [MISSILES & SPACECRAFT] in Chinese No 2, Feb 91 pp 38-41

[Article by Li Qunzhang [2621 5028 4545] of the Beijing General Research Institute of Electronic Engineering: "Rapidly Developing Infrared-Imaging Precision-Guidance Technology"]

[Summary] Although China began its research on IR guidance technology somewhat late, the nation's monoelement and multielement near-IR and mid-IR sensor production technology is now relatively mature. These sensors are critical components in target point-source detection, tracking, and guidance for weapons systems.

Domestic R&D of long-wave IR devices has experienced significant progress since its beginnings in the early eighties. China can now stably manufacture (with a high yield) long-wave monoelement HgCdTe devices with a black-body detectivity D^* of $(2-5) \times 10^{10}$ cm-Hz^{1/2}/W and a responsivity of 10^4 V/W. Real-time high-resolution IR imaging, however, requires high-performance multielement arrays or focal-plane-array devices. Domestic breakthroughs in this area began in 1989, when China announced its development of high-performance 60-element arrays of long-wave HgCdTe devices with a planar-field black-body D^* of 2×10^{10} cm-Hz^{1/2}/W and a responsivity of 10^4 V/W. In the first quarter of 1990, a TV-compatible real-time IR-imaging complete system incorporating this device was domestically developed; the system's sensitivity, spatial resolution, and temperature resolution all match state-of-the-art specifications.

In the mid eighties, China began research on two-color IR sub-imaging guidance technology. A breakthrough in one key technology has already been made, and an engineering-principles prototype is now in development.

The nation has also made progress in R&D of IR-imaging intelligent identification and target tracking. Already in use domestically is an automatic target acquisition and tracking system composed of a domestically developed all-digitized IR-imagery intelligent identification/tracking electronic assembly and an IR thermal imaging instrument. In November 1987, a successful experiment in target acquisition and stable tracking of different types of fighter aircraft under varying weather conditions was carried out. In April 1989, the first successful experiment in nighttime automatic interception and tracking of aircraft targets was conducted, along with successful memory tracking of a low-flying aircraft target by a sheltered tracking system (shown in the accompanying photograph). This represents an important step in the development of IR-imaging precision-guidance technology carried on missiles.

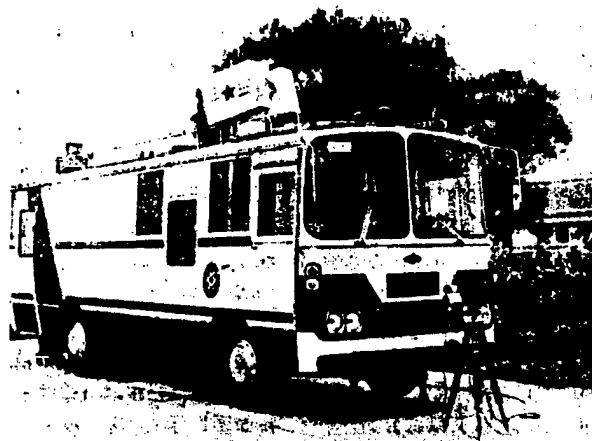

Optical Imagery Precision Tracking System

Finally, China has also realized advances in development of low-noise broadband preamplifiers and micro-coolers for IR imaging equipment.

Polyvalent Antiserum Eliminates Trace Phospholipase A₂ From Membrane Toxins of *Naja naja atra*

40091011I Shanghai SHENGWUHUAXUE YU SHENGWUWULI XUEBAO [ACTA BIOCHIMICA ET BIOPHYSICA SINICA] in Chinese Vol 23 No 2, Mar 91 pp 99-105

[English abstract of article by Zou Zhiyang [6760 1807 2254], Ge Bing [5514 0365], et al., of the Shanghai Institute of Biochemistry, Academia Sinica]

[Text] A method of immuno-adsorption was investigated to eliminate trace amounts of phospholipase A₂ contained in membrane toxins of *Naja naja atra*. Instead of purification of phospholipase A₂ and producing its antibody, the by-product from the isolation of membrane toxins and anti-snake venom antiserum was used, thus making the experiment simple and reliable. The phospholipase activity which contaminated MT-B and MT-C was compared before and after immuno-adsorption.

Expression of the Gene Encoding K88ac Antigen of Porcine Enterotoxigenic *Escherichia coli*

40091011H Beijing SHENGWU GONGCHENG XUEBAO [CHINESE JOURNAL OF BIOTECHNOLOGY] in Chinese Vol 7 No 1, Feb 91 pp 84-87

[English abstract of article by Wu Yaxu [0702 7161 2485], Shi Chenghua [4258 2052 5478], and Huang Cuifen [7806 5050 5358] of the Institute of Biotechnology, Academy of Military Medical Sciences, Beijing]

[Text] The plasmid pMM032 was completely digested with restriction endonuclease EcoRI and HindIII. The resulting two fragments of K88ac gene were recovered and sequentially inserted down stream of the lac promoter of vector pUC19 which was then transformed into *E. coli* RRI. Thirty two of transformants were screened at random for K88ac production by using slide agglutination assay, restriction endonuclease analysis, in situ colony hybridization test and ELISA. Fourteen transformants showed K88ac positive and the expression levels of K88ac were 16-fold higher than that of pMM032.

Study on Rat-Rat Hybridoma Technique and Production of Rat Monoclonal Antibodies Against HIV and HBsAg

40091011G Beijing SHENGWU GONGCHENG XUEBAO [CHINESE JOURNAL OF BIOTECHNOLOGY] in Chinese Vol 7 No 1, Feb 91 pp 66-71

[English abstract of article by Fang Jiachun [2455 1367 2797] of the Department of Cell Biology, Beijing Institute for Cancer Research, Beijing, M. Bodeus, and G. Burtonboy of the Virology Unit, Faculty of Medicine, University of Louvain, Brussels, Belgium]

[Text] The rat-rat hybridoma has some definite advantages in the three system currently utilized for monoclonal antibody production: mouse, rat and human system.

The study on rat-rat hybridoma technique and its application to the productions of monoclonal antibodies against human immunodeficiency virus (HIV) and hepatitis B virus surface antigen (HBsAg) are described as examples in this paper.

Technology of the Production of the Protein Antigens of K88, K99 Diarrhea Vaccine

40091011F Beijing SHENGWU GONGCHENG XUEBAO [CHINESE JOURNAL OF BIOTECHNOLOGY] in Chinese Vol 7 No 1, Feb 91 pp 62-65

[English abstract of article by Gu Danian [7357 1129 1628], Wu Aizhen [1566 1947 3791], et al., of the Shanghai Center of Biotechnology, Chinese Academy of Sciences, Shanghai]

[Text] This paper described that the technology of production of the protein antigens of diarrhea vaccine of K88, K99 by the high cell density fermentation and antigens over expression. The fermentation broth was heated at 65°C for 30 minutes and then removed the cells by the centrifugation. The supernatant containing about 80 percent of the antigen proteins in the broth was precipitated completely with 7 percent polyethylene glycol. The precipitate of protein antigens was collected and lyophilized. The protein antigens of K88, K99 obtained by this method keeps its natural three dimensional structure without treatment with formalin. This is more favorable for the inducing of the production of the antibody, safety, storage and transportation. The protein components of the vaccine showed that the majority of the protein antigen with the molecular weight of 52, 36, 22 and 18 kd.

Insect Resistance of Transgenic Tobacco Plants Expressing δ -Endotoxin Gene of *Bacillus thuringiensis*

40091011A Beijing SHENGWU GONGCHENG XUEBAO [CHINESE JOURNAL OF BIOTECHNOLOGY] in Chinese Vol 7 No 1, Feb 91 pp 1-10

[English abstract of article by Tian Yingchuan [3944 4481 1557], Qin Xiaofeng [4440 2556 1496], et al., of the Institute of Microbiology, Academia Sinica, Beijing]

[Text] The original *B. thuringiensis* δ -endotoxin (Bt toxin) gene clones TH12 and TH48 contain two different classes of homologous genes, the 5.3 kb class and 6.6 kb class respectively. Bt toxin genes of both classes modified at the 5'-end and truncated at the 3'-end can still be expressed to produce the entomocidal, truncated toxin proteins in *E. coli*. The modified Bt toxin genes were inserted into the plant binary expression vector pBin437 (a derivative plasmid of pBin19) and were transferred into tobacco genome by disarmed Ti plasmid pAL 4404 gene transfer system. Southern blot and DNA slot blot analysis indicate that the Bt toxin genes have been integrated into tobacco genome at a copy number of

1-5. Northern blot analysis of poly A⁺ RNAs from progenies of the transgenic plants revealed that Bt toxin genes of both 5.3 and 6.6 kb classes were expressed in transgenic plants, though the transcripts were degraded to RNAs of lower molecular weights. In entomocidal test, 5 plants from the progeny of 5.3 kb class gene-transformed SR1 tobacco plants and 3 plants from that of 6.6 kb class gene-transformed plants were found to be toxic to the testing larvae of *H. assulta*. In comparison with the control, mortality of the insects feeded on transgenic plants reached 40-50 percent and the growth of the survived insects was remarkably inhibited. These results indicated that the modified Bt genes of the 5.3 kb and 6.6 kb classes were expressed in transgenic plants and could confer the transgenic plants a new character of insect resistance.

Subcloning and Expression of δ -Endotoxin Gene and Its 3' End Deletion of *Bacillus thuringiensis* in *Escherichia coli* and *Agrobacterium tumefaciens*

40091011E Beijing SHENGWU GONGCHENG XUEBAO [CHINESE JOURNAL OF BIOTECHNOLOGY] in Chinese Vol 7 No 1, Feb 91 pp 54-61

[English abstract of article by Guo Sandui [6753 0005 1018], Chen Xuejue [7115 1331 6511], et al., of the Laboratory of Molecular Biology, Biotechnology Research Center, Chinese Academy of Agricultural Sciences, Beijing]

[Text] The δ -endotoxin gene from *Bacillus thuringiensis* subsp. *aizawai* 7-29 and the δ -endotoxin gene with 3' end deletion were subcloned into pUC19 plasmid, resulting recombinant plasmids pUCF33 and pUCK63, respectively. After amplification of recombinant plasmids, pGY61 and pGYCK63 were constructed by the insertion of δ -endotoxin gene and its end deletion into plant vector pBI121.2. The DNA of recombinant plasmids pGY61 and pGYCK63 were hybridized positively with α -³²P-labelled Kpn I DNA fragment of 3' end deletion of δ -endotoxin gene. The full length δ -endotoxin gene and δ -endotoxin gene with 3' end deletion were expressed in both *E. coli* HB101 and *A. tumefaciens* LA4404. The cell extracts from transformants of *E. coli* HB101 and *A. tumefaciens* LA4404 are lethal to *Pieris rapae* larvae and *Ostrinia nubilalis* larvae.

Cloning of DNA Fragments With Promoter Function From Temperate Phage of *Bacillus licheniformis*

40091011B Beijing SHENGWU GONGCHENG XUEBAO [CHINESE JOURNAL OF BIOTECHNOLOGY] in Chinese Vol 7 No 1, Feb 91 pp 11-17

[English abstract of article by Sheng Xiaoyu [4141 1420 4416] and Li Yuyan [2621 5148 7122] of the Institute of Genetics, Fudan University, Shanghai]

[Text] Phage B1p7 DNA was digested with restriction endonuclease and ligated to the restriction endonuclease digested vector pTG402. The ligated was used to transform competent cells of *E. coli* MC1061. Plasmid DNA mixture was extracted from pooled transformants and competent cells of

B. subtilis were transformed. By selecting yellow colonies upon spraying with catechol solution, 22 clones containing DNA fragments with promoter function were obtained. The promoter activity of 15 clones was determined by the color reaction of catechol 2,3-dioxygenase. The inserted fragment of the most potent promoter was mapped with restriction enzymes. CatO₂ase activity of two clones was measured in cells of *B. subtilis* of all growth phases and was found to increase rapidly at the end of the log phase. It is inferred that these two promoters might be recognized by sigma 37.

Expression of Hepatitis B Virus Surface Antigen Gene in Insect Baculovirus Vector Systems

40091011D Beijing SHENGWU GONGCHENG XUEBAO [CHINESE JOURNAL OF BIOTECHNOLOGY] in Chinese Vol 7 No 1, Feb 91 pp 37-46

[English abstract of article by Long Qingxin [7893 4851 2450], Su Deming [5685 1795 2494], et al., of the Research Institute of Entomology, Zhongshan University, Guangzhou and the Virology Research Unit, Fudan University, Shanghai]

[Text] The gene coding for the hepatitis B virus surface antigen (HBsAg) under the control of *Autographa californica* nuclear polyhedrosis virus polyhedrin promoter was successfully inserted into the genome of *Trichoplusia ni* nuclear polyhedrosis virus. Infection of *Spodoptera frugiperda* cells with this recombinant virus produced significant amount of HBsAg protein and secreted 22 nm particles containing the HBsAg. HBsAg gene expression was also obtained both in *Trichoplusia ni* larvae and in *Philosamia cynthia ricini* prepupae when infected with the recombinant virus. The HBsAg proteins expressed by baculovirus vector systems are morphological and antigenic properties identical to the 22 nm particles secreted by human cells.

Gene Cloning and Expression of Propionyl Acylase of *Streptomyces mycarofaciens* Mutant

40091011C Beijing SHENGWU GONGCHENG XUEBAO [CHINESE JOURNAL OF BIOTECHNOLOGY] in Chinese Vol 7 No 1, Feb 91 pp 32-36

[English abstract of article by Li Yuan [2621 0337], Sun Yaping [1327 0068 5493], et al., of the Institute of Medicinal Biotechnology, Chinese Academy of Medical Sciences, Beijing]

[Text] Midecamycin producer *Streptomyces mycarofaciens* mutant, which has propionyl acylase activity, can transform spiramycin into propionyl spiramycin. With shot-gun cloning strategy, we used pIJ702 plasmid as a vector to clone DNA fragments of the mutant into *Streptomyces lividans* TK54.

The results of TLC and HPLC showed that the bioconversion product of No. 9 transformant is the same as the propionyl spiramycin. According to these results, the propionyl acylase gene has been cloned in *S. lividans* TK54 and expressed. Molecular weight of insert DNA fragment of No. 9 recombinant plasmid is 4.16 kb. Southern hybridization showed that this fragment originated from midecamycin producer mutant. The restriction map of No. 9 has been constructed.

Reports on New Software Products, Sino-Japanese Joint Venture

Aerospace Industry Engineering Software

91P60174A Beijing JISUANJI SHIJIE [CHINA COMPUTERWORLD] in Chinese No 10, 13 Mar 91 p 13

[Article by Wang Xiren [3769 1585 0088]: "Several New Achievements in Seventh 5-Year Plan Aerospace Industry Engineering Software"]

[Summary] In order to foster more rapid development in the domestic aerospace industry, several new software systems and packages whose development was included in the Seventh 5-Year Plan projects have recently appeared. The list includes computer-technology development and applications products such as CAD/CAM software for IBM hosts, UNIX workstations, and 286 and 386 microcomputers. Especially noteworthy are the CIEM computer integrated design and manufacturing system for aircraft production, the CADISEN system for aircraft engines, the ABE-CIMS system for airborne equipment, the M-CAX system for general-purpose machinery, the MICADX system for software engineering specification, and several software development tools, as well as industrial management systems. Some examples are the 32 copies of a state-of-the-art integrated CAD/CAM software package cooperatively developed with West Germany and distributed throughout China, the LOGICA 3-D curved-surface design software developed by the Shenyang Aircraft Corp., and the independently developed graphics support system CGI-II rated by an IBM users' association as one of the outstanding software products.

Software Engineering Tool Set

91P60174B Beijing JISUANJI SHIJIE [CHINA COMPUTERWORLD] in Chinese No 12, 27 Mar 91 p 9

[Article by Chen Chunmei [7115 2504 2734]: "Ministry of Aerospace Industry Formally Markets 'Software Engineering Tool Set'"]

[Summary] The Ministry of Aerospace Industry's S&T Office has formally announced its "software engineering tool set," developed for the aerospace industry as well as for computer software workers in general. This software tool set, which meets mid-eighties international standards, passed technical appraisal on 24 January 1991. It includes 10 software tools, among which the FOMT-FOR, FOMTC, FOMTBAS, FOMTCOB, FOMTPAS, and FOMTADA are formatting tools (for the FORTRAN, C, BASIC, COBOL, Pascal, and Ada languages, respectively); the remaining four tools are the SCOMS software configuration management system, the DOCGAM software document-generation and management assistance tool, the CSTT software-testing tool for programs written in C, and the windows-based UTTK users' terminal tool kit.

Sino-Japanese Software Joint Venture

91P60174C Beijing JISUANJI SHIJIE [CHINA COMPUTERWORLD] in Chinese No 13, 3 Apr 91 p 2

[Article by Gao Yuqian [7559 3022 0051]: "Japan Sets Up Software Joint Venture in China"]

[Summary] The Japan International Development Organization Ltd. (JAIDO), a Japanese-government-owned [and privately-owned] corporation, has established the "Shanghai Zhonghe [0022 0678] Software Ltd." joint venture with Fudan University's S&T Development Co. This new joint venture has registered capital of US\$3,078,900 supplied by Japan; the contract period is 15 years.

Each year, the joint venture will employ 50 newly graduated students from Chinese universities—principally from Shanghai's Fudan University and from other schools of science and engineering. After one year's study (in China) of the Japanese language and computer-oriented subjects, the new employees will be sent to appropriate JAIDO-affiliated plants and software companies in Japan to work in information processing and software development. After two to three years of on-the-job training, they will return to China to hold posts in the Shanghai joint venture and to engage in software development projects assigned by Japan. The joint venture's software products will be exported to Japan and to other nations. The first group of 50 (from an eventual total of 750) mid-to-high-level software engineers and technicians will begin training in July this year and will start their on-the-job training in June 1992.

Reports on Computer Network Standards, Technologies

First Domestically Developed OSI Prototype System

91P60173A Beijing JISUANJI SHIJIE [CHINA COMPUTERWORLD] in Chinese No 5, 30 Jan 91 p 1

[Article by Liu Jiuru [0491 0046 1172]: "Key State Seventh 5-Year Plan Project in Standardized Network System Technology Bears Rich Fruit"]

[Summary] The nation's first domestically developed main computer-network prototype system complying with the OSI (Open Systems Interconnection) international standard passed acceptance check a few days ago in Beijing. This copyrighted system, jointly developed by MMEI's Institute 15, the CAS Software Institute, Fudan University, Qinghua University, Beijing University, Southeast University, Nanjing University, Xian Jiaotong University, and Huazhong (Central China) University of Science and Technology in a project consuming 150 man-years of R&D work, is a solid foundation upon which China can develop and market its own copyrighted, standardized computer-network product series.

The OSI standard, an advanced technology which integrates data communications, computer networking, and distributed information processing, has a six-layer basic protocol (presentation layer, session layer, transport layer, network layer, data link layer, and physical layer); its seventh layer (the application layer) has been domestically designed for simultaneous operation of VAX, IBM, and Sun computers. The domestically developed OSI prototype, which requires dedicated communications equipment (CP) [communications processors] and includes electronic information, file transfer, and virtual terminal functions, consists of over 30 large modules and over 50 interfaces, and can be linked up with public data networks across the entire nation. Its completely independently designed and written source program contains 350,000 lines and 14Mbytes of code.

The technical experts at the appraisal urged that this system, which meets late-eighties international standards, be commercialized for the domestic and overseas markets as rapidly as possible with the support and investment from appropriate authorities.

Domestically Developed ISDN Model Passes Appraisal

91P60173B Beijing KEJI RIBAO [SCIENCE AND TECHNOLOGY DAILY] in Chinese 19 Mar 91 p 1

[Article by Ji Hongguang [1323 3163 0342] and Liu Yali [0491 0068 0448]: "Telecommunications Integrated Services Digital Network Developed"]

[Summary] Beijing, 18 Mar—An integrated services digital network (ISDN) model network—a technology critical to the development of integrated telecommunications services in the next century—passed appraisal today in Beijing, after a successful trial at the State Planning Commission. This State Seventh Five-Year Plan key S&T project, supported by MPT, permits transmission of sound, data, and/or dynamic imagery via FAX, telegraph, telephone, and data and computer communications, as well as videotex [i.e., a viewdata/view-graphics system]. Jointly developed with very limited state funding by a team of researchers from almost 10 institutions including MPT's Telecommunications Transmission Institute, the model ISDN has a transmission rate of 144 kbps and is designed to interconnect eight similar/dissimilar terminals (of which three may be simultaneously used) over existing copper wires; the system can be linked up with domestically developed packet-switching equipment.

MAN Heterogeneous-Computer Interconnection, TOP/FTAM Software

91P60173C Beijing JISUANJI SHIJI [CHINA COMPUTERWORLD] in Chinese No 13, 3 Apr 91 p 11

[Article by Gao Lihua [7559 7787 5478]: "Two Jiangsu [Province] Computer Network Technologies Pass Appraisal"]

[Summary] Two projects undertaken by Southeast University, the Jiangsu Province Computing Institute, Nanjing Aeronautical Engineering Institute, and Yangzhou Polytechnical College—Nanjing "Metropolitan-Area-Network (MAN) Heterogeneous-Computer Interconnection" and "TOP/FTAM [technical and office protocol/file transfer access method] protocol description and verification [technology] and software"—recently passed the Jiangsu Province S&T Commission acceptance check. The technical experts at the appraisal noted that these two technologies, which comply with the OSI standard, meet mid-eighties and late-eighties international standards, respectively.

The Nanjing MAN heterogeneous-computer interconnection technology, a part of the Jiangsu OSI computer network (JSnet), is based on the seven-layer OSI reference model. For the bottom three layers [i.e., network, data link, and physical], it implements bidirectional point-to-point HDLC/CCU [high-level data link control/communications control unit] interconnected communications between imported mid-sized and mainframe computers (M-240D, IBM 4341, and DPS8) of different types.

The "TOP/FTAM protocol description and verification [technology] and software," a central topic in the State 863 Program CIMS [computer integrated manufacturing systems] project, includes a formalized description and verification of FTAM, the computer-network file-sharing protocol standard put forth by the International Organization for Standardization (ISO). TOP is an office-automation-oriented protocol specification. In the process of TOP/FTAM verification, the research group discovered erroneous and incomplete details in the ISO 8571 international standard; the group's corresponding paper on the discovery was favorably received at the IEEE-sponsored Singapore ICCS'90 Conference. The TOP/FTAM software, oriented to UNIX and XENIX operating systems, can be used with domestically made X.25 communications controllers (developed two years ago) for implementing communications between Sun workstations and PC 386 microcomputers.

High-Speed Composite Computer LAN Built

91P60191 Beijing KEJI RIBAO [SCIENCE AND TECHNOLOGY DAILY] in Chinese 22 Apr 91 p 1

[Article by Wang Qing [3769 7230]: "Large High-Speed Composite Computer Local Area Network Completed"]

[Summary] The large high-speed composite computer local area network (LAN) developed by the China Research Institute of Atomic Energy Sciences (RIAES) has now been completed. This computer LAN, jointly designed and installed by RIAES and Hong Kong's Ji Ao Tai Ke [1015 3421 1132 0344] Co., consists of a fiber-optic ring network and six Ethernets; it permits link-up of heterogeneous computers and has several functions including transparent information transfer. Oriented toward scientific computation and overall management

applications, this computer LAN was certified to mid-to-late-eighties international standards by a panel of experts at the recent acceptance check.

Reports on Optical Disk, Winchester Disk, Floppy Disk Technologies

5.25-Inch Erasable Magneto-Optical Disk Passes Appraisal

91P60171A Beijing ZHONGGUO DIANZI BAO [CHINA ELECTRONICS NEWS] in Chinese 3 Mar 91 p 1

[Article by Pan Ye [3382 6851] and Huang Xin [7806 6580]: "Magneto-Optical Disk Technology at State-of-the-Art Level"]

[Summary] Eighteen topics associated with R&D of a 5.25-inch erasable rewritable magneto-optical disk passed appraisal a few days ago in Shanghai. Developed in a five-year-plus effort by a group of 10 CAS affiliates—including the Shanghai Institute of Metallurgy, the Shanghai Institute of Optics and Fine Mechanics, the Changchun Institute of Optics and Fine Mechanics, the Beijing Institute of Physics (BIP), and the Chengdu Institute of Optoelectronics—working together at the Optical Disk Joint Laboratory, this new disk employs a BIP-developed Mn-Bi-based material with a Kerr angle of rotation of 2.1 degrees; this type of material is being patented in China, the United States, Japan, and other nations.

200-mm Erasable Phase-Change Optical Disk Developed

91P60171B Beijing KEJI RIBAO [SCIENCE AND TECHNOLOGY DAILY] in Chinese 6 Mar 91 p 1

[Article by Liu Dong [0491 2767]: "China Develops Erasable Rewritable Phase-Change Optical Disk"]

[Summary] A 200-mm-diameter [7 7/8 inches] erasable rewritable phase-change optical disk developed over a five-year period by a team from Beijing Aerospace University passed expert technical appraisal in Beijing on 4 March. This 2.4-mm-thick two-sided optical disk, which meets late-eighties international standards, can store the sound and video images from two complete films: a capacity several dozen times larger than that of a floppy disk. Minimum guaranteed information-storage life is 10 years. Testing has shown that the disk fully complies with international standards: the disk's static read-write-erase cycle index [i.e., the number of times the disk may be erased and written over without noticeable data loss] is 1 million, while its dynamic read-write-erase cycle index is over 100,000. In terms of dynamic erase-rewrite carrier-to-noise ratio and degree of erasing, the disk exceeds the values of the comparable product marketed by Japan, the world leader in the field.

More on 200-mm Phase-Change Disk

91P60171C Beijing JISUANJI SHIJIE [CHINA COMPUTERWORLD] in Chinese No 13, 3 Apr 91 p 2

[Article by Wang Yingde [3769 2019 1795]: "Beijing Aerospace University Is First to Domestically Develop Erasable Rewritable Phase-Change Optical Disk"]

[Summary] Testing has shown that the Beijing Aerospace University-developed erasable rewritable phase-change optical disk has a dynamic read-write-erase cycle index of over 200,000 and a static index of 1 million. Heretofore, only Japan has come out with a prototype of this kind of optical disk; now, however, with the first batch of 40 domestically made phase-change optical disks already off the production lines, China too will enter the international market.

135 TPI 3.5-Inch Floppy Disk Head Developed

91P60171D Beijing JISUANJI SHIJIE [CHINA COMPUTERWORLD] in Chinese No 13, 3 Apr 91 p 2

[Article by Lu Xiaoge [0712 2556 2047]: "Another New Achievement in Domestic Manufacturing of Floppy Disk Heads"]

[Summary] A 135 TPI 3.5-inch floppy disk head developed by researchers at Institute 706 of the Ministry of Aerospace Industry's Second Academy has fully met contract design requirements and has easily passed appraisal, marking another successful project following upon the institute's earlier development of 48 TPI and 96 TPI floppy disk heads. Bit density is 8717 BPI, and non-formatted memory capacity is 1Mbyte.

170MB 5.25-Inch Winchester Disk Drive Developed

91P60171E Beijing JISUANJI SHIJIE [CHINA COMPUTERWORLD] in Chinese No 9, 6 Mar 91 p 2

[Article by Zhang Tianyi [1728 1131 0001]: "170MB 5.25-Inch Winchester Disk Drive Developed in Shanghai"]

[Summary] The 170Mbyte 5.25-inch Winchester disk drive (WDD) developed by scientists at Shanghai Jiaotong University's Information-Storage R&D Center passed technical appraisal a few days ago, following upon two years of trials. Manufacturing of this mid-eighties-level WDD will be a Shanghai Municipal S&T joint production priority project in the Eighth Five-Year Plan. If annual production can be geared up to reach an output of 10,000 units during 1992, an annual net income of 25 million yuan can be realized. Were the state to depend totally on imports of this product, the state would be spending about US\$10 million annually. This new disk drive is China's first domestically manufactured high-capacity WDD.

3.5-Inch 20MB Winchester Disk Trial Manufactured

91P60171F Beijing JISUANJI SHIJIE [CHINA
COMPUTERWORLD] in Chinese No 9, 6 Mar 91 p 7

[Article by Lin Jian [2651 0369]: "3.5-Inch 20MB Winchester Disk Trial Manufactured"]

[Summary] The 3.5-inch 20Mbyte Winchester disk developed by MMEI's Institute 32 and manufactured by the Huangpu Instruments Plant represents another step forward in domestic R&D of Winchester disk technology. The new disk, designated as the EPC-211 prototype, has a memory capacity that can be increased to 30Mbytes if a (2,7) coded controller is connected up, and to 38Mbytes if a WDC-5011 controller is hooked in.

600MB Optical Disk Drive Passes Appraisal

91P60171G Beijing JISUANJI SHIJIE [CHINA
COMPUTERWORLD] in Chinese No 12, 27 Mar 91 p 2

[Article by Chang Ming [2490 2494]: "Domestically Developed 600MB Magneto-Optical-Type Optical Disk Drive Meets Operational Requirements"]

[Summary] The model ZPG-1 5.25-inch 652Mbyte magneto-optical erasable rewritable optical disk drive developed by MMEI's Institute 52 passed technical appraisal on 7 March. This new device, which is at a state-of-the-art (early-nineties international standards) level, has a natural resonance frequency of about 8 kHz. With the addition of an STT-521 adapter, the device can be put on line with an AT-bus computer.

5.25-Inch Half-Height 80MB Winchester Disk Drive, Controller Accredited

91P60171H Beijing JISUANJI SHIJIE [CHINA
COMPUTERWORLD] in Chinese No 12, 27 Mar 91 p 2

[Article by Huang Xuchen [7806 2485 2525]: "5.25-Inch Half-Height 80MB Winchester Disk Drive and Controller Unveiled"]

[Summary] At a major MMEI Computer Office-sponsored acceptance-check conference held in Hangzhou 6-8 March 1991, it was announced that the model

ZPC-30 5.25-inch half-height 80Mbyte WDD and model KWT-521 Winchester disk controller developed by MMEI's Institute 52 and manufactured by State-Run Plant 4509 passed technical appraisal on 7 March. The ZPC-30, which meets mid-eighties international standards, employs three types of 2-micron ASICs for servo control and for the ESDI [enhanced small device interface]. The KWT-521, which meets late-eighties international standards, can be put on-line with an AT-bus microcomputer for high-capacity high-speed (10Mbits/s) data communications; it also has an ESDI.

3.5-Inch 4MB Floppy Disk Drive Developed

91P60171I Beijing JISUANJI SHIJIE [CHINA
COMPUTERWORLD] in Chinese No 12, 27 Mar 91 p 2

[Article by Feng Peixian [6785 1014 0341]: "State-Run Jiannan Machine Plant Develops 3.5-Inch 4MB Floppy Disk Drive"]

[Summary] The model JN135J 3.5-inch 4Mbyte floppy disk drive (FDD) developed by MMEI's State-Run Jiannan Machine Plant has passed technical appraisal. This FDD, which employs the traditional stepper motor open-loop-control head-positioning technique, has a track density of 135 TPI. A new Ba-Fe-O vertical recording medium and a broad-pre-wipe read-write head assembly give the new FDD a bit density of 35kBPI; non-formatted memory capacity is 4Mbytes. Heretofore, only Toshiba, Teac, Y E DATA and a few other makers have manufactured this kind of large-capacity FDD.

3.5-Inch 40MB Winchester Disk Drive Developed

91P60190 Beijing ZHONGGUO DIANZI BAO [CHINA
ELECTRONICS NEWS] in Chinese 21 Apr 91 p 3

[Article by Tian Feng [3944 0023] and Yu Bin [0060 3453]: "New Type of Winchester Disk Drive Developed"]

[Summary] The model JN-4050 3.5-inch 40Mbyte Winchester disk drive, jointly developed by the State-run Jiannan Machine Plant and Huazhong (Central China) University of Science & Technology, recently passed its technical appraisal, and will soon be on the market. The experts at the appraisal noted that all of its technical performance indicators meet late-eighties international standards.

Six Types of Optical Logic Gates Realized With Hybrid Optically Bistable Laser Diodes

91P60181 Beijing BANDAOTI XUEBAO [CHINESE JOURNAL OF SEMICONDUCTORS] in Chinese Vol 12 No 4, Apr 91 pp 245-247

[Article by Shi Jiawei [4258 1367 4885] and Jin Enshun [6855 1869 7311] of Jilin University, Changchun, 130023: "Optical Logic Gates Made of Hybrid Optically Bistable Semiconductor Laser Diodes"; MS received 3 May 90, revised 18 Jul 90]

[Summary] Abstract: Using hybrid optically bistable laser diodes composed of semiconductor laser diodes (LDs) and phototransistors (PTs) with different circuit layouts, we have implemented AND, OR, NOT, NAND and NOR optical logic gates. In addition, employing optically parallelable input/output properties, we have implemented the optical exclusive OR (XOR) gate.

Optically bistable devices have proven applications in optical computing and optical information processing¹⁻⁴. We have described the use of the gain-saturation properties of PTs and of the negative-resistance properties of avalanche devices to realize hybrid optically bistable LDs consisting of semiconductor LDs and PTs⁵. A major advantage of this technique is that no other active devices, such as a triode amplifier, are needed⁶, and monolithic integration is therefore easier and device speed can be higher.

The circuit for realizing the AND, OR, NOT, NAND, and NOR logic functions is shown in Figure 1. In the circuit, R_b is a PT bias resistance, R_e is a negative resistance, LD is a 90-mA-threshold laser diode, V_c is a power supply, and C is a capacitor; P_{i1} and P_{i2} are the input intensities, and P_o is the output intensity. The input optical signal, which has an intensity on the order of several tens of microwatts, is provided by a fiber-optic-coupled LED. For each V_c and P_i , varying R_b and R_e will create a device that will serve as a switch, amplifier, or bistable device. Regulating bias current is 70mA, and R_b is 100 Ω . Values of $V_c = 7.0V$ and $R_e = 20\Omega$ constitute the critical state which is the transition from the differential gain mode to the optically bistable mode. Values of $V_c = 7.8V$ and $R_e = 13\Omega$ mark the critical state for transition from the optically bistable mode to the optoelectronic switching mode. When $P_{i1} = P_{i2} \geq P_{on}$ (where P_{on} is the minimum input intensity for switching from a low state to a high state), P_{o1} and the input form an OR gate, and P_{o2} and the input form a NOR gate. When $P_{i1} = P_{i2} < P_{off}$ (where P_{off} is the maximum input intensity for switching from a high state back to the low state) and $P_{i1} + P_{i2} > P_{on}$, P_{o1} and the input form an AND gate and P_{o2} and the input form a NAND gate. The NOT gate (or "inverter") is realized with a single input; one of the two outputs is always the opposite state from the input.

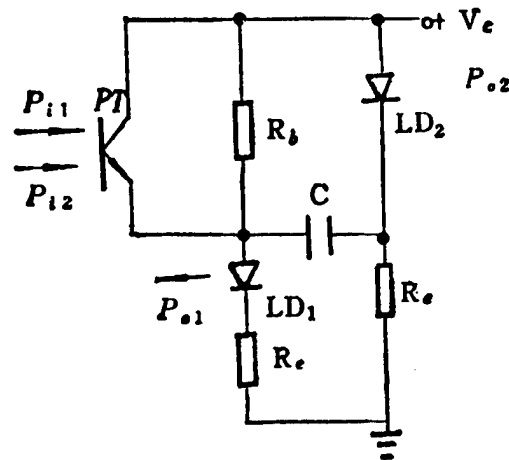

Figure 1. Circuit for Realizing AND, OR, NOT, NAND, and NOR Functions

The circuit for the XOR function, a half-adder without carry, is shown in Figure 2. The XOR gate consists of two PTs and two LDs. When $P_{i1} = "1"$ and $P_{i2} = "0"$, PT_1 goes into avalanche, current I_{c1} goes way up, LD_1 is excited, and the output is a "1". When I_{c2} is very small, LD_2 cannot be excited, and the output is a "0". When $P_{i1} = "0"$ and $P_{i2} = "1"$, with the aforementioned conditions, the LD_1 output is a "0" and the LD_2 output is a "1". When $P_{i1} = P_{i2} = "1"$, due to the series-parallel arrangement of PT_1 , LD_1 , PT_2 , and LD_2 , LD_1 and LD_2 both do not meet requirements for excitation, and both outputs are "0". When $P_{i1} = P_{i2} = "0"$, LD_1 and LD_2 still cannot be excited, and both outputs are still "0". This system of truth-table cases constitutes the XOR function.

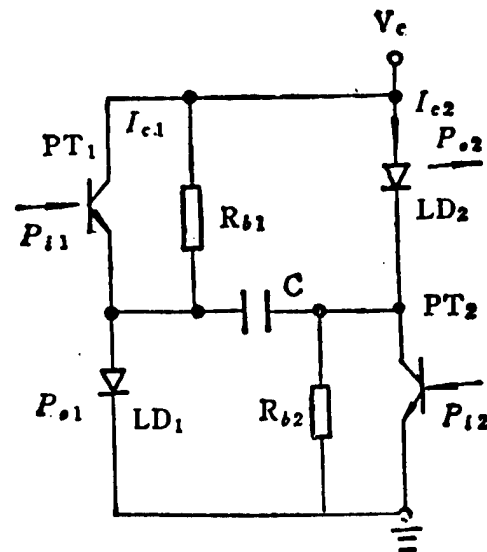

Figure 2. Circuit for Realizing XOR Function

References

1. M. Dagenais and H.G. Winful, APPL. PHYS. LETT., 44, 574 (1984).
2. S.D. Smith and A.C. Walker, ICO-13 Conference Digest, 4487 (1984).
3. K. Okumuia, Y. Ogawa, H. Ito, and H. Inaba, OPT. LETT., 9, 519 (1984).
4. D. Jie, H.X. Kang, and S.B. Ying, IEEE J. QUANTUM ELECTRON., QE-23, 1868 (1987).
5. Jin Enshun, Shi Jiawei, and Xi Junhua, JILIN DAXUE ZIRAN KEXUE XUEBAO [JOURNAL OF JILIN UNIVERSITY, Natural Sciences Edition], 1, 59 (1990).
6. Liu Shutian, Li Chunfei, and Wu Jie, GUANGXUE XUEBAO [ACTA OPTICA SINICA], 9, 983 (1989).

Experimental Research on 'Dual-Target Butt Joint' Ne-Like Ge High-Gain Soft X-Ray Laser
91P60154A Beijing ZHONGGUO KEXUE, Series A, in Chinese No 2, Feb 91 pp 151-160

[Article by Wang Shijie [3769 0013 4921], Gu Yuan [7357 2266], et al. of the China Engineering Physics Institute's Shanghai Laser Laboratory, Shanghai, 201800; Peng Huimin [1756 1920 3046], Sheng Jiatian [4141 1367 3944], et al. of the Beijing Research Institute of Applied Physics & Computational Mathematics, Beijing, 100088; and Lin Zunqi [2651 1415 3825], Wang Shusen [3769 2885 2773], et al. of the High-Power Laser Physics Joint Laboratory (HPLPJL), Shanghai, 201800; "Dual-Target Butt Joint' High-Gain Ne-Like Ge Soft X-Ray Laser Experimental Research"; MS received 20 Aug 90. Reprinting article from JPRS-CST-91-010, 17 May 91 to correct tables]

[Abstract] Utilizing a novel "dual-target butt joint" technique for the two thick, flat, neon-like germanium (Ne-like Ge) targets irradiated by the 1.2×10^{13} W/cm² (12 terawatts per square centimeter target-surface radiant laser intensity) focused output of a 1.053- μ m-wavelength 1-nanosecond-pulse-width, two-beam "Shen Guang" [Magic Light] neodymium phosphate glass laser at HPLPJL, the authors observed five Ne-like Ge spectral lines (the 3p-3s transition lines), with respective wavelengths of 19.6, 23.2, 23.6, 24.7, and 28.6 nm. For the 23.2-nm and 23.6-nm lines, the gain-length product GL exceeded 13. The experimental apparatus is shown in Figure 5 below.

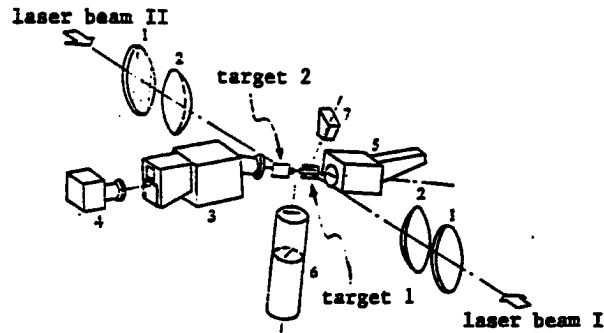

Figure 5. Schematic Diagram of "Dual-Target Butt Joint" Experimental Apparatus

Key: 1. Cylindrical lens array; 2. Aspherical main lens; 3. Planar-focal field grazing incidence grating spectroscope; 4. Scanning soft-X-ray camera; 5. Loran circular grazing incidence grating spectroscope; 6. Dual-slit X-ray camera; 7. KAP flat-crystal X-ray spectrograph

Additional parameters of the experiment are as follows:

- output energy of each laser beam: approx. 600J
- size of laser focal line at target surface: 2.5 cm long x 120 μ m wide
- positional error between two beams: not over 10 μ m
- included angle: not over 1 mrad
- time delay between beams I and II reaching target: 90 plus or minus 5 ps
- size of Ge targets: 2 mm thick (both)
6 mm wide (both)
2.2 cm long (target 1)
0.6-1.8 cm long (target 2)
- planar-focal-field grazing incidence grating spectroscope:
grating nominal grid pitch: $d_0 = (1/1200)$ mm
grating concave curvature radius: $R = 5649$ mm
slit width for incident light: approx. 15 μ m
spacing between slit and target chamber center: approx. 65 mm
grazing incidence angle: 87°
film: Kodak 101-07
spectral wavelength: 5-30 nm
spectral resolution: approx. 0.01 nm
- Loran circular grazing incidence grating spectroscope:
grating grid pitch: $d = (1/1200)$ mm
grating concave curvature radius: $R = 988$ mm
slit width for incident light: 5-30 μ m
spacing between slit and target chamber center: 60 mm
grazing incidence angle: 88°
film: Kodak 101-01
spectral wavelength: 3-30 nm
spectral resolution: approx. 0.005 nm

Ten other diagrams show various graphs of the data and photos of the spectral lines observed. Table 1 below depicts experimental results, while Table 2 compares the results with those of another Chinese lab, a U.S. lab (Naval Research Laboratory), and a British lab (Rutherford Appleton Laboratory).

Table 1. Time-Integrated Gain of Ne-Like Ge 3p-3s Transition Spectral Lines

Wavelength λ (nm)	Experimental results						Simulated results*
	Radiant laser intensity 1.2×10^{13} W/cm ²			Radiant laser intensity 0.8×10^{13} W/cm ²			Gain factor G(cm ⁻¹)
	Max. target length L (cm)	Gain factor G(cm ⁻¹)	Maximum GL value	Max. target length L (cm)	Gain factor G(cm ⁻¹)	Maximum GL value	
19.6	4.0	2.26	9.0	4.4	2.06	9.1	2.81-6.06
23.2	4.0	3.35	13.4	4.4	2.25	9.9	3.20-5.64
23.6	4.0	3.39	13.6	4.4	2.28	10.0	3.04-5.04
24.7	3.4	2.27	7.7	—	—	—	1.54-1.98
28.6	3.4	3.21	10.9	—	—	—	3.28-5.68

*In the computer simulation, radiant laser intensity was $(1.2-1.8) \times 10^{13}$ W/cm², electron temperature T_e in the plasma gain region was about $(7-8) \times 10^6$ K, ion temperature T_i was about 5.6×10^6 K, electron density n_e was about $(1-2) \times 10^{20}$ cm⁻³, Ne-like ion abundance N_i (Ne) was about $0.25 N_i$, F-like ion abundance N_j (F) was about $0.30 N_i$, ion density N_i was about $n_e/23$.

Table 2. 23.6-nm-Wavelength Ne-Like Ge X-Ray-Laser Spectral Line Gain-Length Product (GL) and Its Ratio to Radiant Laser Power (GL/P)

Laboratory*	Radiant laser intensity (10^{13} W/cm ²)	Effective focal line		Gain factor G(cm ⁻¹)	GL value	GL/P (TW ⁻¹)
		Length (cm)	Width (μ m)			
SLL	1.2	4.0	120	3.4	13.6	23.5
NRL ¹¹	0.6	1.8	200	4.1	7.4	34.2
INPC ¹²	1.0	1.8	180	4.0	7.2	22.2
RAL ²	2.5	3.2	150	3.8	12.2	10.1

*SLL: Shanghai Laser Laboratory; NRL: U.S. Naval Research Laboratory; INPC: Southwest Nuclear Physics & Chemistry Institute; RAL: U.K.'s Rutherford Appleton Laboratory.

References

1. MacGowan, B. J. et al., PROC. SPIE, 688 (1986), 36.
2. O'Neill, D. M. et al., OPT. COMMUN., 75 (1990), 406.
3. Jaegle, P. et al., "Proceedings of the OSA Topical Meeting on Short-Wavelength Coherent Radiation: Generation and Applications, Sep. 26-29, 1988"; North Falmouth, Cape Cod, MA, 1990, Vol 2, 21.
4. Matthews, D. et al., OPT. SOC. AM., B, 4 (1987), 575.
5. Hagelstein, P. L., PLASMA PHYS., 25 (1983), 1345.
6. Peng Huimin et al., JISUAN WULI [COMPUTATIONAL PHYSICS], 1 (1990), 91.
7. Chew Wannian et al., CLEO '90, CWF 42 (1990).
8. Eidmann, L. et al., LASER AND PARTICLE BEAMS, 4 (1986), 521.
9. Henke, B. L. et al., ATOMIC DATA AND NUCLEAR DATA TABLES, 27 (1982), 1.
10. Linford, G. J. et al., APPL. OPTICS, 13 (1974), 379.
11. Lee, T. N. et al., PHYS. REV. LETT., 59 (1987), 1185.
12. Peng Huimin et al., IQEC '90, QTh 26, 1990.

Tangible Results Realized From Superlattice & Optoelectronics Research

91P60184A Beijing KEJI RIBAO [SCIENCE AND TECHNOLOGY DAILY] in Chinese 9 Apr 91 p 1

[Article by Fan Jian [5400 1696]: "Splendid Results in Superlattice and Optoelectronics Research"]

[Summary] Three Seventh 5-Year Plan research and development projects assigned to the CAS Institute of Semiconductors—"semiconductor superlattice and microstructures research," "optoelectronics materials, devices, and integration techniques," and "semiconductor information optoelectronic device high-tech R&D"—have all produced tangible results in the form of products judged to be quickly marketable overseas. Recently, these major projects/products passed state acceptance check.

Eighteen specific achievements in the area of semiconductor superlattices—a critical topic in solid-state physics, solid-state electronics, and optoelectronics—are at the international state-of-the-art. They have been described in 286 published scientific papers, which have aroused considerable interest at international conferences.

In the area of optoelectronic materials, devices, and integration, breakthroughs have been made in development of GaAs/AlGaAs high-quality super-thin-film

materials, quantum-well laser diodes, self-electro-optic-effect devices, tunable distributed-feedback laser diodes, and monolithic integrated photo-emitter chips.

In the third and final of the aforementioned areas, breakthroughs have been made in development of six new semiconductor optoelectronic devices, including long-wavelength (1.2 μm and 1.55 μm) uncooled single-mode laser diodes [see JPRS-CST-91-004, 5 Feb 91 p 24] and long-wavelength InGaAs/InP SAGM [separate

absorption, grading and multiplication regions] avalanche photodiodes [see JPRS-CST-91-010, 17 May 91 pp 30-31], as well as three types of equipment including a "laser-diode all-automatic testing system."

These new devices will be manufactured and marketed internationally by the Institute of Semiconductors' Haite [3189 3676] Co. Already constructed are two production lines, one for laser diodes and one for detectors; these lines have an annual production capacity of 10,000 chips.

New OEICs Developed

91FE0561A Beijing ZHONGGUO KEXUE BAO
[CHINESE SCIENCE NEWS] in Chinese 26 Feb 91 p 2

[Article by correspondent Huang Xin [7806 6580]: "New OEICs Developed"]

[Text] The researchers at CAS's Shanghai Institute of Metallurgy recently developed a number of optoelectronic ICs (OEICs) after 5 years of hard work and innovation. They were certified as national high technology items. Consequently, China is among the leaders in OEICs.

OEICs are key components required in the development of ultra-high speed, high-capacity optical communications technology, optical information processing technology, optical sensing technology and optoelectronic computing technology. A research team primarily consisting of young people was led by Research fellow Pan Huizhen [3382 1979 3791]. They overcame a series of design and technical difficulties. For the first time, InP-based high-gain heterojunction bipolar transistors and laser diodes that can be integrated have been fabricated in China. There are only a few developed countries that have the capability to fabricate such OEICs. The degree of integration and functionality have reached the mid-eighties international level, and a domestic void has been filled.

Quantum-Well Laser Diodes, Quantum-Well SEED Developed

91FE0561B Beijing KEJI RIBAO [SCIENCE AND TECHNOLOGY DAILY] in Chinese 28 Feb 91 p 1

[Article by correspondent Fan Jian [5400 1696] from Beijing on 27 Feb 91: "New Generation of Quantum-Well Lasers Developed"]

[Text] In 1990 Bell Labs introduced the first optical information processing computer. Its core is an array of self-electro-optic-effect devices (SEEDs) which operate in symmetry [S-SEEDs]. This high-tech device has now been successfully developed by scientists in China. The event makes China among the world leaders in optoelectronics.

One direction in optoelectronics is to develop quantum-well (QW) laser diodes, which are considered to be ideal light sources. This direction is also used to measure the level of development in optoelectronics as a whole. The Institute of Semiconductors of the Chinese Academy of Sciences has successfully developed a GaAs/GaAlAs superlattice QW SEED bistable device, a high-repetition-rate picosecond GaAlAs/GaAs QW laser diode, and a "low-threshold" GaAlAs/GaAs QW laser diode. These devices will be very useful in optical communications, optical information processing, optical computing and military optoelectronics technology.

The SEED, a topic on the cutting-edge of high technology, has advantages such as low power consumption, high speed, and ease of integration. It will play an important role in digital information processing and optical computing technology. The SEED laser diode developed at the CAS Institute of Semiconductors is based on domestically manufactured materials and device fabrication techniques. Its on-state energy consumption is 5 femtojoules per square micron, its operating wavelength is 100 Angstroms, and the minimum optically bistable voltage is 2 V. Furthermore, it functions as an S-SEED, and as an optical S-R [set-reset] latch [or flip-flop] as well. It is a major breakthrough in the development of superlattice QW devices.

The "high-repetition-rate QW laser diode" is stable up to a temperature of 464 K. Its maximum lasing temperature is 152°C and the wavelength is 0.85 micron. The modulation frequency is 1-6 GHz. The narrowest pulse width is 16 picoseconds and the maximum pulse peak power is 240 milliwatts.

Famous scientists such as CAS Academic Committee member Ye Peida [0673 1014 1129] believe that this major accomplishment in the "863" Plan should be applied to optical communications, optical information processing and digital optical computing as soon as possible.

Semi-Insulating GaAs Monocrystal Developed for High-Speed ICs

91FE0561C Beijing KEJI RIBAO [SCIENCE AND TECHNOLOGY DAILY] in Chinese 4 Mar 91 p 1

[Article by Liu Yali [0491 0068 0448] and Ji Hongguang [1323 3163 0342] from Beijing on 2 Mar 91: "High-Speed ICs Successfully Developed"]

[Text] Beijing Institute of Non-Ferrous Metals has successfully developed semi-insulating (SI) GaAs monocrystal, which is in great demand for the manufacture of very-high-speed ICs [VHSICs] and OEICs. This work was certified as a technical accomplishment in the Seventh 5-Year Plan. The material is already in production and can satisfy more than 60 percent of the market demand in China.

High-quality SI GaAs monocrystal is the ideal material for high-speed electronic devices and digital VHSICs. It has a wide range of applications in defense, aerospace and microwave communications. In recent years, as computer and other high technologies become more advanced, more and more ICs are made of SI GaAs. Because this product is considered a high-tech item, industrialized nations are banning the export of this material to China. For a while, it limited the development and production of VHSICs. During the Seventh 5-Year Plan, Beijing Institute of Non-Ferrous Metals was assigned the development task. It overcame difficulties including insufficient funding and inability to import key technology from abroad and completed the work in 5 years.

Based on a briefing given by the experts on the certification committee, this is a novel technique involving high-pressure direct compounding, shift crystal pulling and whole ingot annealing. It overcomes the light-sensitive problem. The quality of an entire batch of product can be stabilized with excellent reliability and reproducibility. The monocrystalline parameters are comparable to those of foreign products developed in the mid 1980's. Its social benefit is apparent and is a very practical product.

ASIC-Based Intelligent Logic Design System Developed

91FE0561D Beijing ZHONGGUO DIANZI BAO [CHINA ELECTRONICS NEWS] in Chinese 8 Mar 91 p 3

[Article by Xue Wu [1331 2976] and Jian Zhong [1696 0022]: "ASIC-Based Intelligent Logic Design System Developed"]

[Text] A key technical project in the Seventh 5-Year Plan, an ASIC-based intelligent logic system, LODAS90, has been developed by Professor Liu Mingye [0491 2494 2814] and his associates at Beijing Science and Engineering University, and was recently certified by the Microelectronics Department of the Ministry of Machine Building and Electronics Industry.

The ASIC intelligent logic system performs the description of behavior function for input to the mask-making system. It uses DDL language to input the description of the circuit. After behavior simulation, hardware logic translation and consolidation, an EDIF/CIF form of mask-making input is obtained.

The system consists of eight components including the behavior ASIC, description language DDL, hardware logic translation machine, dataflow consolidation unit, and automatic logic-diagram generator. Key components such as the hardware logic translation machine and dataflow consolidation unit are being studied in detail theoretically. On the basis of previous work, new theories and algorithms have been proposed. For example, a single-scan method is used in hardware logic translation and an operator distribution scheme approximately equivalent to the cluster division method is used in data-flow consolidation. In automatic logic-diagram generation, the bus layout is done first and then followed by element layout in order to solve problems such as excessively long time and large storage space. This approach eliminates obstacles that prevent the system from being practical. The basic theory and schemes have few constraints. It can be directly used with other hardware languages such as VHDL [VHSIC hardware description language].

Experts pointed out that the system is the first in China that finishes the entire process from behavior description, design input to logic diagram generation. It creates new territories for ASIC in China. The key technology used in the system has reached mid 1980 world level.

Mask-Alignment Exposure Machine, MOCVD Equipment, Chip-Carrier Sintering Station Developed

91FE0561E Beijing ZHONGGUO DIANZI BAO [CHINA ELECTRONICS NEWS] in Chinese 10 Mar 91 p 3

[Article by Wang Changhe [3769 7022 0419]: "Mask-Alignment Exposure Machine, MOCVD Equipment, Chip-Carrier Sintering Station Developed by Institute 13"]

[Text] Three types of semiconductor equipment developed by Institute 13 of the Ministry of Machine Building and Electronics Industry, i.e. the JB-II mask-alignment exposure machine, YL-1 MOCVD [metallo-organic chemical vapor deposition] equipment, and ST-1 chip-carrier sintering station, recently passed expert technical appraisal.

The JB-II mask-alignment exposure machine is a micron-level high-precision exposure machine. It is suitable for lithography on 1-4 inch Si, GaAs, and InP wafers in the fabrication of VLSIs and microwave devices. On a 4-inch wafer, a fine pattern of better than 1 micron resolution can be achieved. The alignment precision is +/- 0.5 micron. The exposure mode may either be hard contact, soft contact or vacuum contact. The machine employs an ocular two-stage cold reflection exposure system to cancel diffraction. The primary exposure spectral line is the h line. It also covers both i and g line. The equipment uses an automatic micro-force alignment platform which is on an error-compensated tripod. It is especially suited for the lithography of fragile wafers such as GaAs and InP.

The YL-1 MOCVD equipment was developed based on requirements for advanced semiconductor devices such as GaAs microwave and millimeter-wave devices, GaAs VHSICs, long-wavelength laser diodes and integrated optical devices. MOCVD and MBE have become essential equipment for the development of novel microelectronic devices and VHSICs in the 1990s. MOCVD has several unique advantages, including homogeneity and controllability, compared to VPE (vapor phase epitaxy) and LPE (liquid phase epitaxy). Its growth rate and alloy composition can be individually controlled to make ultra-thin film at molecular level. Compared to MBE, MOCVD is significantly better in terms of production efficiency and material size.

The ST-1 chip-carrier sintering station was developed for the welding between the chip and carrier in the fabrication of devices such as microwave semiconductor devices, laser diodes and LEDs. An immense current pulse is used to instantaneously heat up the flux. It is rapidly melted and rapidly cooled to avoid surface oxidation. This helps lower the thermal resistance of the device. The chip is handled by vacuum suction. It is convenient and can prevent damage done to its active layer. Thus, the effective yield is improved. This

machine is on trial in an optoelectronic-device production line, where the user found a noticeable improvement in yield.

ICCAD/ICCAT/ICCAM System Developed

91FE0561F Beijing ZHONGGUO DIANZI BAO [CHINA ELECTRONICS NEWS] in Chinese 10 Mar 91 p 3

[Article by Li Qiongrui [2621 8825 3843] and Jie Yannan [6043 3601 0809]: "Major Breakthroughs in Microelectronics; ICCAD/ICCAT/ICCAM System Developed"]

[Text] More good news comes from the microelectronics front. Domestic research on the most advanced technology in microelectronics, i.e. ICCAD (integrated circuit computer aided design), ICCAT (integrated circuit computer aided testing) and ICCAM (integrated circuit computer aided management), has resulted in a number of outstanding accomplishments among which is the ICCAD three-level system jointly developed over a 5-year period by nearly 400 experts from 26 institutions. On February 25-27, the ICCAD/ICCAT/ICCAM system, whose development was a key State Seventh 5-Year Plan project, passed the acceptance check administered by a State-organized panel of experts.

Microelectronics is the foundation of the electronic information industry and ICs are the pillars of microelectronics technology. This system has the capability to perform various functions required in the design of an IC, including pattern editing, logic simulation, circuit simulation, automatic layout and routing, and verification. The system can handle the design of a full-custom circuit with up to 50,000 elements (or 100,000-element memory devices). The appraisal committee, created with experts and relevant personnel from the State Planning Commission, the State S&T Commission, the Ministry of Machine Building and Electronics Industry, the State Education Commission, and the Chinese Academy of Sciences, pointed out that this ICCAD system is the first comprehensive ICCAD system independently developed using software engineering techniques. Its success lets China join the U.S., Japan and western Europe as countries with the capability to develop a large-scale ICCAD system. It pushes our microelectronics technology forward by a giant step, thus shortening the distance to the state-of-the-art. In addition, it breaks the embargo imposed by Western nations on the exporting of ICCAD systems. In the development process, China also had the opportunity to train domestic ICCAD teams of experts.

The appraisal committee gave high marks to the 12 IC testing programs and 256 testing packages, the established ICCAT program database, and the Chinese-character-based ICCAM system. These ICCAD/ICCAT/ICCAM related accomplishments have laid a solid foundation for IC technology and industry in China.

1.5-Micron VLSI Technology, 1 Mbit Chinese-Character ROM Pass Acceptance Check

91FE0561G Beijing ZHONGGUO DIANZI BAO [CHINA ELECTRONICS NEWS] in Chinese 13 Mar 91 p 1

[Article by Jie Yannan [6043 3601 0809]: "1.5-Micron VLSI Technology, 1 Mbit Chinese-Character ROM"; cf. earlier report in JPRS-CST-91-007, 25 Mar 91 pp 20-21]

[Text] One of the key technical projects in the Seventh 5-Year Plan, "Development of 1.5-Micron VLSI Technology and 1 Mbit Chinese-Character ROM," passed State acceptance check on March 3. This accomplishment puts us in a new stage in the research and development of VLSI technology. It is a major breakthrough in microelectronics.

With the full support of the government, after years of effort, Qinghua University has finished construction on the first micron-level CMOS VLSI pipeline-type production line in the nation, and has independently developed CMOS VLSI complete fabrication technology with 1.5-micron design specifications. The entire process has been designed and in-process testing procedures established. Breakthroughs were made in key techniques such as exposure of fine lines, mask etching, high-quality thin-film oxidation, shallow junction and metallization.

The first 1 Mbit Chinese-Character ROM ever developed is on a 6.4mm x 6.5mm Si chip with over 1,060,000 transistors integrated on it. It takes two ROM chips to store a level-2-standard Chinese character database (approximately 7,000 Chinese characters and some relevant Chinese and foreign symbols) with characters meeting the national standard. It will be widely used in computers and office automation equipment with Chinese-character capability. The product is already used in the Chinese Learning Computer. It was found to be at advanced level and could totally replace imports.

In the area of computer-aided simulation and fundamental process research associated with 1-micron VLSI technology, the Institute of Microelectronics of the Chinese Academy of Sciences and Beijing University have made encouraging progress in R&D of silicate thin-film properties, self-alignment technique, shallow-junction ohmic contacts, ultra-thin silicon oxide interface properties, and 0.6-micron ASIC technology. Some results are at a world-class level. In addition, the following projects were appraised: optimization of 3-micron CMOS and ECL IC processing technique, 5-micron bipolar simulation, optimization of digital circuit and CMOS circuit processing techniques and analysis of materials and process defects. In the optimization process, a total of 94 types of ICs were developed and manufactured; over 23 million chips with an output value of 90 million yuan have been fabricated.

GaAs Microwave Power FETs, Other Devices from Institute 13 Pass Appraisal

*91FE0561H Beijing ZHONGGUO DIANZI BAO [CHINA
ELECTRONICS NEWS] in Chinese 15 Mar 91 p 1*

[Article by Liu Dong [0491 2639]: "Seven Devices From Institute 13 Pass Appraisal"]

[Text] On March 1, 1991, seven items developed by Institute 13 of the Ministry of Machine Building and Electronics Industry passed appraisal at Shijiazhuang. These accomplishments fulfil important domestic needs.

The packages for models PA72, LC84, PA88 and LC124A LSI chips are products listed under national key S&T projects. The technical level is comparable to that of similar foreign products in the 1980's. In addition, the DX661 GaAs microwave power FET, DX651 GaAs microwave power FET, and WD431 Si microwave broadband pulse power transistor also passed appraisal. They have the highest performance characteristics among similar domestically made products.

Six New ICs Developed by Institute 24

*91FE0561I Beijing ZHONGGUO DIANZI BAO [CHINA
ELECTRONICS NEWS] in Chinese 15 Mar 91 p 3*

[Article by Cai Shiwei [5591 0013 0251]: "Six New ICs Developed by Institute 24"]

[Text] Institute 24 of the Ministry of Machine Building and Electronics Industry recently developed six new ICs: the S1534/S1334 1500MHz/1300MHz divide-by-four frequency divider, the X1558C dual operational amplifier, the X120S side-tone IF amplifier, the X441 logarithmic amplifier, the CM7511DITD quad duplex analog switch and the CM201 quad duplex analog switch. The S1534/S1334 1500MHz/1300MHz divide-by-four frequency divider is the first product manufactured in China using advanced oxide isolation planar SI technology and all-ion-implantation technology. Its advantages include wide operating frequency range, high sensitivity, large dynamic range, simple wiring and ease of use. It may be used in ultra-high-frequency communications and instrumentation. Its temperature behavior is better than comparable products made in other countries. The X1558C dual op amp has advantages such as wide differential and common-mode input voltage range, blockage-free large-signal input, output short protection and internal compensation. It is stable, reliable and easy to use and is interchangeable with the foreign-made MC1558G. The X120S side-tone IF amp has high input-limiting sensitivity and good AM suppression and is stable and reliable. It has a wide range of uses in television and communications, and is interchangeable with the foreign-made TBA120S. The X441 logarithmic amp can be used in radar, infrared detection and communications and is interchangeable with the foreign-made TL441. The CM7511DITD quad duplex analog switch provides overvoltage protection; it is lockout-free, has low resistance and low power consumption, and can

be used in areas such as communications, radar, measurement and automation instrumentation. Its performance specifications are comparable to those of the U.S.-made AD7511DITD. The CM201 quad duplex analog switch has high switching speed, wide analog signal amplitude range, high current capacity, and low resistance; it does not lock up, is highly reliable and stable and has excellent interference-resistance. It can be used as a signal channel switch in aeronautics, as well as in switches in sampling protection circuits and as a program-controlled op-amp switch. It is interchangeable with the foreign-made HI201.

VLSI-Oriented Rapid Heat Treatment Equipment Developed

*91FE0561J Beijing ZHONGGUO DIANZI BAO [CHINA
ELECTRONICS NEWS] in Chinese 17 Mar 91 p 1*

[Article by Jie Yannan [6043 3601 0809] and Liang Shu [2733 2118]: "VLSI-Oriented Rapid Heat Treatment Equipment Developed"]

[Text] A state-of-the-art infrared fully automated rapid heat treatment (RHT) machine, completely independently designed and developed in China as a key State Seventh 5-Year Plan project, passed appraisal at Qinghua University on March 3. It is a critical piece of equipment necessary for the development and production of VLSI circuits in the 1990s. Because conventional IC heat treatment involves high temperature over long periods of time, it is not suitable for micron- and sub-micron-level VLSI technology. RHT technology has become a key technology in the fabrication of LSI and VLSI circuits. Many countries have developed lamp-based RHT machines and over a dozen companies are manufacturing such equipment. However, problems such as uneven heating, high energy consumption and high cost make it impractical to use in production. The RHT equipment employs techniques such as using large graphite plates as the infrared radiation source and adding reflective plates to solve these problems. Applications of RHT include heat treatment of implanted Si and GaAs materials, development and production of ICs, recrystallization of SOI [silicon-on-insulator], and formation of silicates; the equipment greatly facilitates progress in these areas, and its study has laid a good foundation for annealing equipment. The RHT machine has received two Chinese patents and one U.S. patent; in addition, it received a second-class national invention award in 1990. This equipment is in use at research institutes under the Chinese Academy of Sciences, higher-education institutions, the Ministry of Machine Building and Electronics Industry and the Ministry of Aerospace Industry. Not only is a great deal of foreign exchange saved, but also a large amount of electricity is conserved. (Each unit saves 140,000 kilowatt hours per year.) The machine is now available for export.

ASIC-Oriented 3-Micron CMOS Fabrication Technology Studied

91FE0561K Beijing ZHONGGUO KEXUE BAO
[CHINESE SCIENCE NEWS] in Chinese 19 Mar 91 p 1

[Article by Huang Xin [7806 6580] "Advanced ICs in Production in Shanghai"]

[Text] A CAS Shanghai Institute of Metallurgy research team led by Zhang Minshuai [1728 2404 3764] investigated the optimization of 3-micron CMOS fabrication technology as a key project in the State Seventh 5-Year Plan and created a new way to independently design and domestically produce ASICs, and in cooperation with Shanghai Beiling Microelectronics Corporation the institute has now developed fabrication technology for typical mid-to-high-performance ASICs. A micron-level double-layer metal-mesh silicon grid technology was optimized to reduce the IC area by 60 percent, compared to that of the original single-layer design. On this basis, their technical staff successfully developed 13 types of gate-array LSI circuits for use in automatic control, NC machine tools and computers. They include the first independently designed 16-bit high-speed logic operation circuit and the nation's first super-minicomputer networking circuit, both circuits fabricated on a 2000-gate substrate. These products, which are at a world-class level, are already in production at Beiling, where a stable yield has been obtained.

ASIC-Oriented Si-Gate CMOS Gate-Array Design System Developed, Accredited

91FE0561L Beijing ZHONGGUO DIANZI BAO [CHINA ELECTRONICS NEWS] in Chinese 22 Mar 91 p 3

[Article by Yue Ziqiang [2867 1311 1730]: "ASIC-Oriented Si-Gate CMOS Gate-Array Design System Developed, Accredited"]

[Text] Two key Seventh 5-Year Plan projects—Si-gate CMOS single- and double-layer-wiring gate-array design systems—were successfully developed by the Department of Electronic Engineering, Fudan University. The single-layer Si-gate CMOS gate-array design system has the following special features: (1) The layout of the system is scientific and rational. It consists of 15 modules, including automatic layout and automatic routing. In particular, the automatic mother-board formation module, interactive database design module, and automatic and interactive contact distribution module are more convenient and practical than the imported Daisy system. With 3-micron technology, the system scale can be as high as 2000 gates (approximately 10,000 transistors). (2) It employs an advanced algorithm to optimize the wiring in order to achieve high density. Using 3-micron technology with 2000 gates, the chip area is reduced to approximately 30 square millimeters and the circuit performance is improved. (3) It is adaptive to different variations. For instance, it was successfully used by the Kaide [0418 1795] Corporation in Beijing in the design of 350-, 750- and 2000-gate 3-micron wafers.

The utilization rate of the highest 2000-gate ASIC is 93.4 percent, and chip area has been reduced from 6.7 mm x 5 mm to 5 mm x 5 mm.

The double-layer Si-gate CMOS gate-array design system has the following special features: (1) The design of the mother chip is very simple. Once the core unit and peripheral unit dimensions are determined and scale and channel numbers are given, the mother chip can be automatically formed by the design routine. More than 99 percent of the wiring is done automatically (gate utilization rate is approximately 90 percent), a value substantially higher than that for the imported Daisy system, and close to that for the Mentor software package. (2) For the same IC, under identical design requirements, the chip area can be reduced by approximately ¼ using the double-layer design. With 3-micron technology, a 4500-gate IC is 6.6 mm x 6.4 mm. The macro-element database available to date can accommodate up to 6000 gates.

GaAs/AlGaAs Heterojunction HEMT Passes Appraisal

91FE0561M Beijing ZHONGGUO DIANZI BAO [CHINA ELECTRONICS NEWS] in Chinese 24 Mar 91 p 3

[Article by Tong Lin [0157 3829]: "GaAs/AlGaAs Heterojunction HEMT Passes Appraisal"]

[Text] The high electron mobility transistor (HEMT) IC developed by the Microelectronics Center of the Chinese Academy of Sciences recently passed expert appraisal in Beijing. The HEMT is a new-generation very-high-speed, low-noise electronic device developed in the 1980s. It has become an important branch of VLSI technology. This area of research began fairly late in China; work on single-transistor and ring-oscillator test circuits was not completed until the end of 1990. Hence, it is of great significance to investigate heterojunction very-high-speed HEMT devices and circuits. The Microelectronics Center and the CAS Shanghai Institute of Metallurgy began research on a project called "GaAs material, devices and integration" in 1988. The Center first concentrated on epitaxial VHSICs. After more than 2 years of effort, a 0.8-1.5-micron-gate-length GaAs/AlGaAs heterojunction HEMT has been developed using MBE (molecular beam epitaxy) and HEMT IC fabrication technology. At room temperature, its transconductance is 90-110 milliSiemens/mm and its pinch-off voltage is about -0.7 V. Its monolithic pinch-off voltage deviation is 60 mV. Based on the two batches of three wafers fabricated for research, the yield is 70 percent. This work has laid an excellent foundation for digital VHSIC HEMT development. The experts at the acceptance check believed that this device has reached a mid-eighties international level.

VLSI High-Density Chip-Carrier Product Series Passes Appraisal

91FE0561N Beijing ZHONGGUO KEXUE BAO
[CHINESE SCIENCE NEWS] in Chinese 29 Mar 91 p 2

[Article by Liu Changan [0491 7022 1344] and Zheng Zhaosen [6774 0340 2773]: "VLSI High-Density Chip-Carrier Product Series Passes Appraisal"]

[Text] A wireless ceramic chip-carrier multi-pin-array product series incorporating a high-density packaging material for VLSI chips passed appraisal by the Ministry of Machine Building and Electronics Industry in early March at Shijiazhuang. This product series not only indicates the successful completion of a high-density-packaging project in the Seventh 5-Year Plan, but also provides a good start in our attempt to catch up with the world in this field.

VLSI high-density packaging is a new technology developed for the ever-increasing degree of integration of LSI (large scale integration). It involves a number of difficult technologies such as flow of ceramics, fine printing, precision lamination, hole drilling and through-hole metallization, high-temperature sintering, electroplating and testing. The project was headed by Institute 13 of the Ministry of Machine Building and Electronics Industry. After solving various problems, a series of seven products including the LC68A and PA88 were developed from late 1989 through 1990. Tests show that these products have excellent mechanical, electrical and thermal properties and meet national standards. Their reliability passes the seven special technical conditions specified in QZJ840614 for semiconductor ICs. User trials showed that various specifications meet requirements for ECL 600-gate-to-1200-gate and CMOS 1000-gate-to-10,000-gate gate-array ICs. These products meet 1980s standards for comparable products made abroad.

The development of VLSI packaging technology will help the rapid growth of our key electronic systems, mainframe computers, supercomputers and microcomputer systems.

In addition, a 4 GHz 8-watt GaAs microwave power FET developed by Institute 13 was accredited. This is a key device in microwave communications, mobile communications and guidance systems. The successful development of this transistor is a major contribution to the domestic production of high-power solid state devices. We are no longer dependent upon foreign imports which require a great deal of hard currency.

New High-Speed Devices, Optoelectronic-Device Materials Developed

91FE0561O Beijing ZHONGGUO DIANZI BAO [CHINA ELECTRONICS NEWS] in Chinese 29 Mar 91 p 1

[Article by Fang Shifen [2075 0013 5358]: "New High-Speed Devices, Optoelectronic-Device Materials Developed"]

[Text] On March 14, five technical accomplishments achieved by the Institute of Semiconductors of the Chinese Academy of Sciences passed appraisal at Beijing. The development of a high electron mobility transistor integrated circuit (HEMT IC) involves the use of chemical beam epitaxy equipment and was a key national project in the Seventh 5-Year Plan. In addition, quantum-well (QW) laser-diode materials, GaAs/AlGaAs superlattice QW SEED [self-electro-optic-effect device] material and InP-InGaAs material were also accredited.

The experts believe that these accomplishments have reached levels comparable to similar foreign accomplishments of the mid-to-late eighties. They are significant breakthroughs in the development of high-speed devices and optoelectronic materials which provide a solid foundation for the development of optical communications and optical computer technology.

The HEMT is the key element in ultra-high-frequency VHSICs. The core is a doped heterojunction material with very high electron mobility. The Institute conducted studies to modify the MBE equipment, improve material growth techniques and optimize growth conditions and finally developed a high-quality modulation-doped heterojunction material with an electron mobility of $1.52 \times 10^5 \text{ cm}^2/\text{V}\cdot\text{s}$ at 77 K. HEMT ICs made of this material are being used in high-performance ring oscillators here in China.

The Institute, in collaboration with Shenyang Scientific Instrument Plant, developed the first CBE equipment made in China. Its major specifications are comparable to those of foreign-made products developed in the late 1980s. This provides the necessary equipment to prepare ultra-thin films and fills a domestic void.

The SEED, now being rapidly developed worldwide, is a key component in optical information processing and optical computing technology. The several-hundred-cycle PIN [positive-intrinsic-negative] multi-QW material fabricated with equipment developed by the Institute was tested to have a well-width fluctuation and interface planeness both at the atomic level. It exhibits the apparent ambient-temperature lasing effect and the quantum confined Stark effect. The major specifications of SEEDs made from such material have reached world-class levels as of the late 1980s. Institute researchers modified a piece of imported MOCVD [metallo-organic chemical vapor deposition] equipment to convert it into the first machine capable of making ultra-thin InP film at 50 mbars [pressure]. Also, for the first time, they developed GaInAs/InP QW material that is lattice-matched to InP.

32-Bit SPARC-Chip Logic Design Further Described

91FE0561P Beijing JISUANJI SHIJIIE [CHINA COMPUTER WORLD] in Chinese No 13, 3 Apr 91 p 9

[Article by Xiao Qiang [1366 1730]: "Major Step Forward Toward Domestically Made High-End Workstations"; cf. earlier report in JPRS-CST-91-006, 5 Mar 91 p 25]

[Text] A major breakthrough has been made in the study of "RISC [reduced instruction set computing] technology and its applications" by a Fudan University research team led by Associate Professor Hong Zhiliang [3163 1807 5328]. Using a standard 2-micron CMOS double-layer-Al-wiring cell, the team successfully designed a 32-bit RISC logic diagram (simulated) which is compatible with SPARC [scalable processor architecture] instructions. This is an important step towards domestic production of high-end workstations. This key city industrial project has reached a mid-1980s level.

The "heart" of a workstation is a RISC chip. It is difficult to develop, has very high technical requirements and is expensive. In a 2-year effort, the Fudan University researchers designed the SPARC logic diagram by combining microelectronics with computer technology. This effort lays a solid foundation for production in the Eighth 5-Year Plan.

This accomplishment has the following special features:

(1) It employs a pipeline structure. The forward circuit design for the latches [i.e. flip-flops] and comparators can overcome competition in the pipeline operation. If the next ALU [arithmetic logic unit] command requires the use of the result rewritten by the previous ALU command, or the ALU command following a Load command needs the loaded data, the forward circuit can short the ALU result and loaded data directly to the ALU entrance. Thus, the pipeline efficiency is improved. (2) It has the capability to get a command ahead of time. A command is input into a buffer (FIB) [forward input buffer]. Because data and commands share the same 32-bit bus, and different commands have different cycles, this problem can be solved by inputting commands into buffers. The FIB is capable of categorizing commands based on different types in order to maintain different times and capability to get a command ahead of time. A maximum of three commands can be maintained to improve efficiency in execution jump and data I/O. (3) It uses a register-oriented design. The register document employs an overlapping window structure. In addition to eight global registers, the remaining 112 registers form a latching ring with seven overlapping windows. Each window has 24 registers; eight for output, eight as local registers, and eight for output. Every output register for a current window is also the input register for the next window in order to enhance the execution efficiency of the called command. (4) It has the capability to respond to interrupt commands and handle traps. It is capable of jumping to "reset," "error," and "run" in the system. Fourteen different traps may be generated; based on the trap type and interrupt priority, it determines whether to respond to or generate a trap or to back out of a trap. First, it preserves PC and NPC and then modifies TBR. Based on the trap TBR, it determines the program address to treat the trap. Through the enter command, the system returns to the run mode.

Near-Resonance Scattering Studies of Longitudinal Optic Phonon Modes in GaAs/AlAs Superlattices

40100053D Beijing BANDAOTI XUEBAO [CHINESE JOURNAL OF SEMICONDUCTORS] in Chinese Vol 12 No 5, May 91 pp 317-321

[English abstract of article by Wang Zhaoping, Han Hexiang, Li Guohua, and Jiang Desheng of the National Laboratory for Superlattices and Microstructures, and Institute of Semiconductors, CAS, Beijing, 100083, China; and Klaus Ploog of the Max-Planck-Institute fuer Festkorperforschung, 7000 Stuttgart 80, Germany; MS received 12 Nov 90, revised 19 Dec 90]

[Text] Room-temperature and near-resonance scattering studies of longitudinal optic phonons in GaAs/AlAs superlattices are presented. Samples were grown by MBE method on semi-insulating GaAs substrates. Excitation light sources were 6471 and 6764 Angstroms line of Kr-ion laser. At near-resonance conditions, scattering intensities of LO even modes with A_1 symmetry are much more enhanced than those of LO odd modes with B_2 symmetry. Even modes were only observed with polarized configuration, while odd modes were observed with depolarized one as in the case of off-resonance scattering. Second-order scattering spectra were also observed.

Epitaxy of CdTe Single-Crystal Films on GaAs Substrates by ICBE

40100053C Beijing BANDAOTI XUEBAO [CHINESE JOURNAL OF SEMICONDUCTORS] in Chinese Vol 12 No 5, May 91 pp 294-299

[English abstract of article by Fen Jiayou, Tang Haipeng, Zhu Honglin, Fan Yudian, and Li Hengde of the Department of Material Science and Engineering, Qinghua University, Beijing 100084; MS received 29 Jul 90, revised 19 Nov 90]

[Text] Both (100) and (111) CdTe epitaxial layers have been grown on (100) GaAs substrates by ionized cluster beam epitaxy (ICBE). X-ray diffraction and RHEED [reflection high-energy electron diffraction] patterns show that the epitaxial layers are single-crystal films. The best epitaxial layer obtained on GaAs substrate exhibited a (100) CdTe DCRC having a FWHM of 630 seconds of arc. The dependence of orientation and quality of CdTe epitaxial layer on growth conditions are studied. It is found that the epitaxial orientation relationships are: (100) CdTe/(100) GaAs by substrate preheating at 480°C; (100) + (111) CdTe/(100) GaAs by substrate preheating at 580°C. The quality of CdTe epitaxial layer is directly related to the kinetic energy of CdTe clusters.

Studies of Reaction Characteristics and Electronic Properties at Cr/GaAs Interfaces

40100053B Beijing BANDAOTI XUEBAO [CHINESE JOURNAL OF SEMICONDUCTORS] in Chinese
Vol 12 No 5, May 91 pp 265-272

[English abstract of article by Jin Gaolong, Chen Weide, and Xu Zhenjia of the Institute of Semiconductors, CAS, P. O. Box 912, 100083, Beijing, China and Structure Research Laboratory, USTC, Hefei, 230026, China; MS received 28 Jun 90, revised 20 Aug 90]

[Text] The reaction characteristics and electronic properties at Cr/GaAs interfaces during deposition of Cr on GaAs(100) have been studied in detail. For coverage of $\theta < 25$ Angstroms, no chemical reaction was observed but As out-diffusion occurred slightly and a patch model can be used to account for this reaction onset when sequentially depositing Cr on GaAs(100). The As out-diffusion is one of the important factors to trigger the interface disruption. For $\theta = 0.6$ Angstroms, the Cr2p core level peak shifts 0.30 eV to a lower binding energy compared with that of pure metal Cr. Meanwhile, the Cr2p core line shape is widened and of greater asymmetry compared with that of pure metal Cr. These peculiar electronic properties compared with that of other 3d metals have been discussed taking into account the special electronic structure of Cr. Because of stronger interdiffusion of Cr and reaction with As at the interface after annealing, As out-diffusion was stopped. However, the out-diffusion of the remainder gallium at the interface grew slightly.

Charge DLTS and Its Application to Deep-Level Measurement of Gallium Arsenide on Silicon

40100053A Beijing BANDAOTI XUEBAO [CHINESE JOURNAL OF SEMICONDUCTORS] in Chinese
Vol 12 No 5, May 91 pp 257-264

[English abstract of article by Dong Qi, Zheng Xinyu, Chen Peiyi, and Fei Xinbo of the Institute of Microelectronics, Qinghua University; MS received 5 Jul 90, revised 14 Oct 90]

[Text] A novel charge DLTS [deep-level transient spectroscopy] method with leakage current compensation function is put forward and demonstrated. Possessing the same spectroscopic characteristics as the conventional DLTS technique, it directly measures the charge response of deep-level thermal emission rather than relying on modulation of the depletion region width. Therefore, the new method can be used for materials such as semi-insulator, PIN and SOI structures. A micro-computer-controlled measurement system is established. All the DLTS information is available simply by one temperature scanning. The densities and positions of the deep levels in the active region of the LED made of GaAs grown on Si by MBE have been measured for the first time. Existence of high-density deep levels in the material is proved.

A New Approach to Hierarchical Floorplanning for Building-Block Layout

40100052B Beijing BANDAOTI XUEBAO [CHINESE JOURNAL OF SEMICONDUCTORS] in Chinese
Vol 12 No 4, Apr 91 pp 238-244

[English abstract of article by Ying Changsheng, Hong Xianlong, and Wang Erqian of the Department of Computer Science and Technology, Qinghua University, Beijing, 100084; and J. S. L. Wong of the Department of Electronic Engineering, Hong Kong Polytechnic, Hong Kong; MS received 5 Jun 90, revised 1 Sep 90]

[Text] A new hierarchical floorplanner for custom VLSI design which allocates space for rectangular modules and space for the wiring among the modules in a hierarchical manner is presented. The system is divided into three phases: clustering with module dimension estimation, top-down floorplanning, and bottom-up floorplan refinement. The key novel features include: a "natural" clustering algorithm for design physical hierarchy, analytic models for initial placement and spacing, a fast Steiner-tree algorithm for global routing and performing routing area estimation in floorplanning. Unlike other hierarchical floorplanners, no constraint is imposed on the layout topology used to construct the floorplan. The experimental results show that the hierarchical floorplanner achieves fairly high area usage while satisfying various constraints on aspect ratio and I/Os.

Monte Carlo Modeling of Steady Characteristics for Submicrometer GaAs MESFET

40100052A Beijing BANDAOTI XUEBAO [CHINESE JOURNAL OF SEMICONDUCTORS] in Chinese
Vol 12 No 4, Apr 91 pp 211-217

[English abstract of article by Zhao Honglin, Li Binqiao, and Chen Hongda of Tianjin University; MS received 15 Mar 90]

[Text] A submicrometer GaAs MESFET has been studied using the Monte Carlo particle modeling method. Steady output characteristics have been successfully obtained. The simulated device has fairly high transconductance and well-saturated output current. High electric field exists in both the conductive channel and the region between gate and drain. Within the device, there are a lot of hot electrons. Many of them are excited into X band in the drain region. It can be inferred that the electrons in the conductive channel have high drift velocity, but their average drift velocity will be lowered in the drain region because the electrons in the X band have larger effective mass.

Pressure Behavior of $\text{In}_x\text{Ga}_{1-x}\text{As}/\text{GaAs}$ Strained Quantum Wells With Different Widths

40100051C Beijing BANDAOTI XUEBAO [CHINESE JOURNAL OF SEMICONDUCTORS] in Chinese
Vol 12 No 3, Mar 91 pp 177-183

[English abstract of article by Li Guohua, Zheng Baozhen, Han Hexiang, and Wang Zhaoping of the

National Laboratory of Semiconductor Superlattices and Microstructures, Institute of Semiconductors, CAS, Beijing; MS received 26 Jun 90]

[Text] The photoluminescence of $\text{In}_x\text{Ga}_{1-x}\text{As}/\text{GaAs}$ strained quantum wells with widths of 30 Angstroms to 160 Angstroms have been studied at 77 K under hydrostatic pressure up to 60 kbars. It is found that the pressure coefficients of exciton peaks from 1st condition subband to heavy-hole subband increase from 9.74 meV/kbar for 160 Angstroms well to 10.12 meV/kbar for 30 Angstroms well. The calculation based on the Kronig-Penney model indicates that the extension of electronic wave function to barrier layer in the narrow wells is one of the reasons for the increase in pressure coefficients with the decrease in well width. Two peaks related to indirect transition were observed at a pressure higher than 50 kbars.

Study of Modulation Spectrum of Semiconductor Quantum Wells

40100051B Beijing BANDAOTI XUEBAO [CHINESE JOURNAL OF SEMICONDUCTORS] in Chinese
Vol 12 No 3, Mar 91 pp 150-155

[English abstract of article by Qian Shixiong, Yuan Shu, Wu Jianyao, and Li Yufen of the Department of Physics, Fudan University, Shanghai, P. R. China; and T. G. Andersson of the Department of Physics, Chalmers University of Technology, Goteborg, Sweden; MS received 5 Jul 90]

[Text] Using the phototransmission spectrum technique, we have measured the phototransmission spectra from $\text{In}_x\text{Ga}_{1-x}\text{As}/\text{GaAs}$ single-quantum-well samples. The clear modulation structure of different excitons in InGaAs well has been determined. From the fitting based on the electric field-modulation mechanism, the

exciton energies have been obtained and found to be in good agreement with other measurements and theoretical calculation.

Investigations on Optical Properties of GaInAs/AlInAs Multiple Quantum Well Heterostructures

40100051A Beijing BANDAOTI XUEBAO [CHINESE JOURNAL OF SEMICONDUCTORS] in Chinese
Vol 12 No 3, Mar 91 pp 136-144

[English abstract of article by Jiang Desheng and Li Feng of the National Laboratory of Superlattices and Microstructures and Institute of Semiconductors, Beijing; Zhang Yonghang and Klaus Ploog of the Max-Planck-Institute fuer Festkoeperforschung, Stuttgart; MS received 2 Aug 90]

[Text] The optical properties of GaInAs/AlInAs alternating multiple quantum well heterostructures (MQWH), lattice-matched to InP substrate, are investigated. The low-temperature absorption, photoluminescence (PL), PL excitation spectra and the temperature dependence of transmission spectra are measured for the MQWH samples with different well widths. The detected PL peaks from MQWH samples are mainly due to transition processes related to defect states. However, up to room temperature the intrinsic heavy-hole and light-hole exciton peaks are still well observed in the absorption spectra, showing clearly the two-dimensional character of the electronic states. The red shift of inter-subband transition energies with increasing temperature is determined and explained. The calculation of subband energies by Kronig-Penney model indicates that, in order to get a satisfactory fitting to the measured values it is necessary to take the non-parabolicity of conduction and valence bands into account. In connection with X-ray double crystal diffraction measurements, such structural parameters as layer thickness, residual strains and the composition homogeneities are analysed.

Status & Future of, Recommendations for Nation's Superconductivity R&D

91FE0501A Beijing XIANDAIHUA [MODERNIZATION]
in Chinese No 2, 23 Feb 91 pp 22-24

[Article by Han Shuo [7281 2592]]

[Text] "Superconductors" became a hot topic in the late 1980's. However, there was a substantial base in superconductor technology and applications in China before it happened. As a matter of fact, it began in the 1960's in China.

Early Accomplishments in Using Superconductors

From the standpoint of applications, the following major accomplishments were obtained before 1980. In 1959, a helium liquefier was developed to produce liquid helium. In 1965, the first-generation single-conductor superconducting NbTi wire was developed. Preliminary work was done in conjunction with superconducting energy storage using a laser power supply in an attempt to build a magnetic mirror for controlled nuclear fusion experiments. In 1973, in response to the need in high-energy physics research, a variety of multi-conductor superconducting wires and dc and pulsed magnets were developed. Research on superconducting tunnel-junction devices and weak magnetic devices also began at that time. In 1976, research began on dc and ac motors. At the same time, studies on large superconductors for MHD (magnetohydrodynamic) power generation and controlled nuclear fusion experiments also began. In addition, preliminary work on superconducting magnets for industrial applications got underway. Since 1981, after reviewing what we had accomplished in the Sixth 5-Year Plan and taking the situation in China into account, our main target has been to develop medium and small magnets for industrial applications. To this end, different superconducting magnets, high-field magnets, high-field Nb₃Sn ribbons and multi-conductor wires have been developed.

Still in Laboratory Research Stage

Superconducting Magnet Technology: Research on superconducting strong magnets began very early. A steady-state superconducting magnetic mirror was developed in 1974 for controlled nuclear fusion experiments, but it was not used. In early 1980, the development of superconducting magnets for use in bubble chambers for high-energy physics experiments and pulsed superconducting magnets for accelerators prompted the domestic production of multi-filament NbTi superconducting wires. However, due to a change in goals of high-energy physics research, these efforts were re-directed. Later, in work on superconducting motors, progress was made in the development of an 800 kW superconducting synchronous motor and a 300 kW single-stage motor for ship use. Development of large superconducting magnets for MHD has been in progress for several years. In addition, some institutions are conducting research on

superconducting magnetic separation. Development of various prototypes and experiments on mineral separation are in progress.

In work on medium and small superconducting magnets, some success has been obtained in the development of superconducting magnets for the phase enhancer of an astronomical telescope, cyclotron, and scientific instruments such as a Mossbauer spectrometer and magneto-spectrophotometer. In addition, the development of a 200-250 MHz nuclear magnetic resonance (NMR) spectrometer magnet is also in progress. We also plan to develop 300 MHz and higher-frequency magnets.

The latest progress is the successful development of a superconducting magnet for a 0.6 T NMR imaging system. It will be used in the field in the near future.

Superconducting Electronics: Our efforts have been focussed on SQUIDs (superconducting quantum interference devices), a Josephson voltage standard, microwave devices and high-speed signal processors. We have completed the development of an Nb/Si/Nb device, tunnel-junction and DC-SQUIDs, and an Nb point-junction RF-SQUID. However, they have not yet been commercialized.

The first-generation Josephson voltage standard has been completed, and accuracy has reached the 10⁻⁹ level, a value comparable to the international standard. In microwave and high-speed signal processing, an 8 mm quasi-particle frequency mixer has been developed and is close to being installed on a radio telescope.

The above is a summary of superconductor technology in strong and weak magnet applications in China. Despite the fact that a few items are close to practical use, as a whole, most of them are still in the laboratory development stage. There is a desperate need to make progress toward practical applications.

Major Problems

(1) We are used to laboratory work. However, laboratory research and product development are not tied together. Technology cannot be made for practical use. To date, we do not have a single complete superconductor product that can operate satisfactorily over a long period of time. For instance, superconducting instruments such as NMR spectrometers and imaging systems and SQUID magnetometers have been commercialized abroad. These instruments come complete with refrigeration units, testing instruments and power supplies; they are high-quality products and are very competitive. There is a major gap between these products and ours. To date, we do not have a complete product on the market. A domestically developed SQUID magnetometer has not been fully commercialized yet.

(2) In the area of research, there are many simple engineering installation projects. In terms of application and commercialization, research on key technologies is insufficient. In some cases, attempts to take shortcuts

even add to the lead time. For example, our inability to solve key problems such as the welding of dissimilar superconductors and the manufacture of low-temperature Dewars has a big impact on progress toward practical applications. Furthermore, R&D of superconductivity cannot be raised to a higher level until improvements in the properties of long superconductor wires and manufacturing capabilities are made and until technologies associated with low-temperature structural materials, low-temperature insulators and low-temperature testing are developed.

(3) With regard to high-critical-temperature (high-T_c) superconductors, we have reached a certain level in bulk and thin-film processing technology and research on practical use of superconductors. However, basic and applied research on promising high-T_c superconductors must be included in the agenda. There is already an alarming gap in applied research.

(4) The biggest problem in applied superconductor research is the lack of a long-term plan and steady investment. The development of superconductors and associated applied technology was included in the S&T plan of the Sixth 5-Year Plan. However, with the exception of high-T_c superconductors, other projects are not in the national S&T plan in the Seventh 5-Year Plan and there is no investment whatsoever. Most of the work has been terminated. This kind of disruption is not good for the development of superconductors.

Countermeasures

In view of our technical level and economic strength, we must concentrate our efforts on the development of useful superconductor technology that eventually can be commercialized. As for long-range applications that require substantial investment, we should focus on basic research and international cooperation in order to track its progress and provide technical training.

The following measures are recommended.

(1) The Government should have a long-range plan for superconductor R&D and arrange short-term projects.

Superconductor technology has a very promising future. It is built on a foundation of high-technology development and enormous financial support. It is still not mature and is not yet a large-scale industry. Its near-term development would not attract any interest from private corporations. It needs government support to provide a long-term plan and to make some near-term arrangements. The Government has to create certain conditions and offer some financial assurances. In addition, it needs to encourage various departments to jointly invest in superconductors. It must bring in some competition and support more qualified institutions with better technical conditions and well-trained personnel. Different organizations are encouraged to cooperate in the form of joint research and development projects. The government should gradually create the conditions necessary to form

a national research center where the best equipment and people are concentrated to accelerate R&D of superconductor technology.

(2) Product development is the goal of China's applied superconductor technology.

In the past, a great deal of progress was made in applied superconductor technology. Nevertheless, no products were developed. This is primarily due to diffused effort and lack of interest in product development. Therefore, we should concentrate our efforts on the development of products that are already available in the marketplace and products for which the technology is relatively mature in order to be effective. To this end, resources must be concentrated and efforts can be divided into three different levels.

The first level is to support the immediate development of products that are already available; China has the conditions to develop such products which will result in great social and economic benefits. These products include medium and small superconducting magnets, NMR spectrometers and imaging magnets and SQUID devices, and superconducting magnetometers.

The second level is to conduct laboratory prototype development of products for the not-so-distant future which will result in substantial economic and social benefits based on relatively mature technology. This will accelerate the commercialization process. These projects must be carefully chosen based on market forecast and technical and economic feasibility analyses.

The third level is to conduct basic applied research programs on items which potentially have a great impact on the economic growth, but involving a great deal of difficulties and large investment sums.

We can track the progress made in other countries regarding these expansive projects in order follow the development trend.

(3) Coordinate the development of low-temperature and high-T_c superconductors.

The emergence of high-T_c superconductors brings about a new direction in applied superconductor technology. It makes it possible to outperform conventional technology from a technical and economic standpoint. However, a great deal of work is still required to make the present high-T_c superconductors useful in practical applications. It is estimated that thin-film high-T_c superconductors will be used in electronics first. The development and use of high-current-density wire is going to take some time. Therefore, it is still necessary to develop applications for low-temperature superconductors which are being used now. In the foreseeable future, both high- and low-T_c superconductors must be developed in a coordinated manner.

(4) Pay attention to R&D of superconductors, cryogenics and related technologies.

The development of superconductor technology depends upon related technologies. It involves many disciplines that form an integral system. Especially, superconductor technology and cryogenics are the basics. In the past, we were more interested in prototype development rather than products. We did not ask much of cryogenic technology. If we have to develop a superconducting product, then cryogenic technology often plays a key role. Of course, the development of cryogenic technology also matches the requirements of superconducting magnets and devices. In addition, sufficient attention must be paid to low-temperature structures and low-temperature insulating materials.

(5) Take advantage of the policy of opening up to import technology for absorption and digestion.

With regard to products already on the market, we can form joint ventures. As we import small quantities of products, we must purposefully bring in advanced foreign technology for us to absorb and digest. Within a short period of time, we must make our own products to replace imports and even develop our own export market. With regard to items still in the laboratory, we should strengthen international academic exchanges and cooperation in order to lift our superconductor technology to the next level as soon as possible.

Experimental Observation of V-Sr-Tl-O System With 170K Transition Temperature

91P60188 Beijing KEXUE TONGBAO in Chinese
Vol 36 No 7, 1-15 Apr 91 pp 504-506

[Article by Liu Zhiyi [0491 1807 3015], Jia Shunlian [6328 7311 5571], et al. of the State Superconductivity Laboratory, CAS Institute of Physics, Beijing, 100080: "Experimental Observation of V-Sr-Tl-O System, Indications of Superconductivity"; MS received 17 Oct 90]

[Abstract] A recent Hitachi research institute report in NIKKEI SUPERCONDUCTORS¹ describes the discovery by Aihara et al. of a highly unstable vanadium-strontium-tantalum-oxide (V-Sr-Tl-O) system with zero resistance at 132K and with extremely weak diamagnetism near 50K; the system is considered a superconductor by Aihara.

In our own experiment, we took V_2O_5 , $SrCO_3$, and Tl_2O_3 in a 1:1:0.2 mix (total Tl content about 3 percent), and sintered it at 850-900°C in an H_2/Ar composite atmosphere for 5-8 hours. After cooling and polishing, we obtained a 13 x 1.5 [?mm] wafer, which was then sintered at 900-940°C in an H_2/Ar atmosphere for 10-25 hours to form a blackish ceramic substance.

With only three of the samples, we obtained results similar to those of Aihara et al. The transition temperature we derived is relatively high (>170K), as shown in Figure 1.

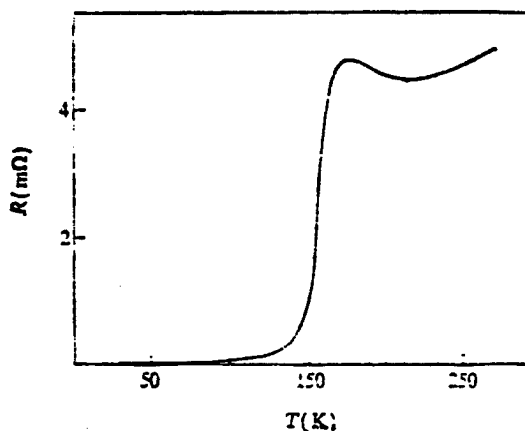

Figure 1. Plot of Resistance vs. Temperature for Fresh Samples

At 165K, resistivity was approximately $9.7 \times 10^{-4} \Omega\text{-cm}$ and fell to $2 \times 10^{-5} \Omega\text{-cm}$ near 135K and to $5 \times 10^{-6} \Omega\text{-cm}$ at 57K. As measured with a Lake Shore AC susceptometer (model 7000), diamagnetism appeared near 135K, and at 80K diamagnetic susceptibility was 5.7×10^{-5} (cgs units). After 2 days, measurements carried out with the same samples revealed that the samples had basically lost their diamagnetism, and that antiferromagnetic transition had taken place, with the transition temperature near 85K; the samples had in effect become semiconductors.

Due to the highly unstable nature of the system, we cannot be certain that the phenomenon is indeed superconductivity, but it at least is a new phenomenon. Deeper investigation and more uniform sample preparation techniques are needed.

Three additional figures (not reproduced) depict various curves of the experimental data.

References

1. Katsuzo Aihara, et al., NIKKEI SUPERCONDUCTORS, 1990, 9:20.
2. F.J. Morin, P.R.L., 3 (1959), 830-833.

Flux Creep in Sintered Bi(Pb)SrCaCuO Bulk Superconductor

40100050B Beijing DIWEN WULI XUEBAO
[CHINESE JOURNAL OF LOW TEMPERATURE PHYSICS] in Chinese Vol 13 No 2, Mar 91 pp 126-130

[English abstract of article by Feng Shangshen and Cao Xiaowen of the Institute of Plasma Physics, CAS, Hefei, 230031; Sun Yuping, Jiang Jianyi, Yin Huaqing, and Du Jiaju of the Institute of Solid State Physics, CAS, Hefei, 230026; MS received 9 Jun 90]

[Text] The flux creep rate at 77.3 K for the fields below 2,000 Oe, and the relation between flux creep rate and temperature for the fields of 150 and 300 Oe have been experimentally researched in Bi(Pb)SrCaCuO bulk

superconductor. The flux pinning potential is estimated, U_0 proportional to $H^{-\alpha}$ with $\alpha = 0.87$ in the fields from 50 Oe to 800 Oe, with $\alpha = 0.28$ in the fields from 800 Oe to 2,000 Oe. There is a decrease of flux pinning potential U_0 with increase of temperature above 77.3 K in a certain field.

Synthesis, Structure and Properties in (Bi, Pb, Sb)-Sr-Ca-Cu-(O, F) Superconductors

4010050A Beijing DIWEN WULI XUEBAO
[CHINESE JOURNAL OF LOW TEMPERATURE
PHYSICS] in Chinese Vol 13 No 2, Mar 91 pp 114-121

[English abstract of article by Wu Xiaoling, Gao Xiaohui, Jiang Shufen, and Wei Qin of the Central South University of Technology, Changsha, 410083; MS received 7 May 90]

[Text] (Bi, Pb, Sb)-Sr-Ca-Cu-(O, F) superconductors with zero-resistance temperature at 115 K have been synthesized successfully. The relations between the chemical composition, preparation techniques, the crystal structure and high- T_c superconductivity have been investigated. The effects of fluorine and stibium on the thermodynamics and results of electromagnetic measurements and X-ray diffraction show that a 151 K super-high- T_c phase exists for this superconductor.

References

1. Michel, C., et al., ZEIT. PHYS. B., 68 (1987), 421.
2. Green, S. M., et al., "Zero Resistance at 107 K in the (Bi, Pb)-Sr-Ca-Cu-Oxide System" (Preprinted).
3. Gao Xiaohui, Wu Xiaolin, et al., MODERN PHYSICS LETTERS B, 4 (1990), 137-144.
4. Liu Hongbao, et al., SOLID STATE COMMUNICATIONS, 69 (1989), 867-868.
5. Cao Xiaowen, et al., "The Flux Creep in High- T_c $\text{Bi}_{1.7}\text{Pb}_{0.3}\text{Sr}_2\text{Ca}_2\text{Cu}_3\text{O}_y$ Bulk Superconductor" (to be published).
6. Naoto Kijima, et al., JAPANESE JOURNAL OF APPLIED PHYSICS, 27 (1988), L1852-L1855.
7. Endo, U., et al., JAPANESE JOURNAL OF APPLIED PHYSICS, 27 (1988), L1567.
8. Chen Wuming, et al., JOURNAL OF NANJING UNIVERSITY, 24 (1988), 735-737.
9. Gao Xiaohui, et al., CHINESE JOURNAL OF CHEMICAL PHYSICS, 3 (1990), 57-63.

Effect of Bi/Pb Ratio and Annealing Temperature on T_c ($R=0$) and Formation of High- T_c Phase in Bi-Pb-Sr-Ca-Cu-O System

40100050E Beijing DIWEN WULI XUEBAO
[CHINESE JOURNAL OF LOW TEMPERATURE
PHYSICS] in Chinese Vol 13 No 2, Mar 91 pp 152-155

[English abstract of article by Xi Zhengping and Ji Chunlin of the Northeast University of Technology, Shenyang, 110006; and Zhou Lian of the Northwest Institute for Nonferrous Metals Research, Baoji, 721014; MS received 11 Mar 90]

[Text] We have studied the effect of Bi/Pb ratio and annealing temperature on T_c and the formation of the high- T_c phase in the Bi-Pb-Sr-Ca-Cu-O system by means of the "three-step reaction" process. The optimum Bi/Pb ratio is about 1.8:0.3 and the optimum annealing temperature is about 845-855°C. It is found that a variant high- T_c phase exists at the higher annealing temperature. The zero-resistance temperature of the variant high- T_c phase decreases with increase of annealing temperature, although the phase is isostructural to the 110 K phase.

Oxygen Content, Structure and T_c of 110K Single-Phase Bi(Pb)-Sr-Ca-Cu-O Superconductor

40100050C Beijing DIWEN WULI XUEBAO
[CHINESE JOURNAL OF LOW TEMPERATURE
PHYSICS] in Chinese Vol 13 No 2, Mar 91 pp 131-135

[English abstract of article by Wang Nanlin of the Department of Physics, University of Science and Technology of China, Hefei, 230026; Tan Minqiu and Wang Jingsong of the Department of Physics; Zhang Shiyong of the Department of Chemistry, Zhejiang University, Hangzhou, 310027; Sha Jian and Jiang Hongbo of the Department of Physics, University of Science and Technology of China, Hefei, 230026; and Zhang Qirui of the Department of Physics; MS received 22 May 90]

[Text] 110 K single-phase Bi(Pb)-Sr-Ca-Cu-O superconductors have been prepared by the method of co-decomposition of nitrates. It is found that reduction of oxygen content, the transition temperature decreases, and the modulation period of the superlattice along the b axis increases. It is considered that the interstitial oxygens incorporated into the Bi-O layers are affected mostly by the heat-treatment process. The depression of T_c is caused by the decrease of the hole concentration due to the reduction of these oxygens.

Investigation, Fabrication of Nb_3Sn Magnets in NbTi-Nb₃Sn Hybrid Superconducting Magnet System

40100050F Beijing DIWEN WULI XUEBAO
[CHINESE JOURNAL OF LOW TEMPERATURE
PHYSICS] in Chinese Vol 13 No 2, Mar 91 pp 156-164

[English abstract of article by He Mu, Hu Shanrong, and Sun Yue of the Shanghai Institute of Metallurgy, CAS,

200050; Lin Liangzhen, Li Kewen, and Lin Guiying of the Institute of Electrical Engineering, CAS, Beijing, 100080; Meng Qinghui, He Yeye, and Li Bing of the Cryogenic Laboratory, CAS, Beijing, 100080; MS received 8 Apr 90]

[Text] The Nb_3Sn magnet which is made of $(NbTi)_3$ Sn conductor by Ti-doping and Nb-tube method and is processed with the techniques of "non-even current density wind design," "wind and react" and "epoxy-impregnation" is found suitable to be used as the insert magnet in the NbTi- Nb_3Sn hybrid superconducting magnet system. It is of excellent high-field performance, small size, light weight, quick excitation speed and strong ability of withstanding quench. The magnets with clear bores of 28.5 mm (wt. 2.5 kg), 30.3 mm (wt. 3.0 kg) and 41 mm (wt. 3.95 kg) have successfully been used in the NbTi- Nb_3Sn hybrid superconducting magnet systems of applied centre field 14T, 12T and 11T, respectively.

Bi(Pb)-Sr-Ca-Cu-O(F) Superconducting Thin Films

40100050D Beijing *DIWEN WULI XUEBAO*
[CHINESE JOURNAL OF LOW TEMPERATURE
PHYSICS] in Chinese Vol 13 No 2, Mar 91 pp 148-151

[English abstract of article by Shi Xiangqing, Huang Xiaomei, Yang Caibing, and Cao Xiaoneng of the Institute of Electronics, CAS, Beijing, 100080; MS received 12 Feb 90]

[Text] Pb-doped Bi-Sr-Ca-Cu-O thin films were prepared by resistive evaporation of Bi, Pb, Cu, SrF_2 and CaF_2 onto (100) MgO substrates. The deposited films were then post-annealed at 850°C in wet and dry oxygen for 1-3 hours. The resistive superconducting transition has an onset at 116 K and zero resistance at 103 K.

Latest Reports on Fiber Optic Communications**2-5-Micron-Wavelength HgCdTe Receiver Developed**

91P60172A Beijing ZHONGGUO DIANZI BAO [CHINA ELECTRONICS NEWS] in Chinese 3 Mar 91 p 3

[Article by Yue Ziqiang [2867 1311 1730]: "Fiber Optic Communications Oriented Mercury-Cadmium-Telluride Receiver"]

[Summary] A 2-5- μm -wavelength mercury-cadmium-telluride (HgCdTe) receiver (or detector) developed over a three-year period by the Shanghai Institute of Technical Physics for infrared (IR) fiber optic communications use recently passed technical appraisal. This important device for the development of DS5 [565Mb/s] ultra-long-wave, high-capacity, ultra-long-range IR fiber optic transmission systems has a three-layer ($n^+/n^-/P$) structure. Testing by the CAS Shanghai Institute of Optics and Fine Mechanics and by Shanghai Jiaotong University has demonstrated that the device meets mid-eighties international standards.

Tianjin-Tanggu Unrepeated DS4 System Accredited

91P60172B Beijing ZHONGGUO DIANZI BAO [CHINA ELECTRONICS NEWS] in Chinese 29 Mar 91 p 1

[Article by Wang Xun [3769 6598]: "Tianjin-Tanggu DS4 Unrepeated Fiber Optic Cable System Passes Appraisal"]

[Summary] An independently designed and constructed DS4 (140Mb/s, 1920 simultaneous voice circuits) long-range unrepeated metropolitan inter-bureau communications system using domestically made equipment and fiber optic cable—the Tianjin-Tanggu inter-bureau fiber optic cable system—passed state acceptance check on 21 March in Tianjin. This State Seventh Five-Year Plan priority S&T project, undertaken by the Tianjin Fiber Optic Information Technology Joint Development Co., is the highest-capacity longest-unrepeated-range (total length of 46 km) digital fiber optic line to be built in the nation yet. The system employs six-fiber single-mode ducted optical cable. Five months of trial operation have shown that the system meets mid-eighties international standards.

Domestic Optical Cable Laid Surpasses 12,000 Km Mark

91P60172C Beijing KEJI RIBAO [SCIENCE AND TECHNOLOGY DAILY] in Chinese 30 Mar 91 p 1

[Article by Jing Chaoyu [5427 2600 3254]: "Nation's Communications 'High-Speed Superhighway' Is on the Ascendant; 12,000 Km of Fiber Optic Cable Put Into Use"]

[Summary] Liang Jian [2733 0256], director of MPT's Fiber Optic Communications Office, revealed to this reporter the other day that, up to the end of last year, a

total of 12,000 kilometers of fiber optic cable had been laid throughout the nation for P&T public networks and for other special public networks. Over 40 cities nationwide employ municipal fiber optic communications lines, and over 10 provinces have built long-distance fiber optic cable trunklines. In the above system, 56 percent of the equipment was imported and 44 percent domestically made. In the current Eighth Five-Year Plan, MPT is building a 20,000-km-long high-capacity digital fiber optic cable networked system to connect the capital with all major cities and with the coastal regions. In the first phase of this project, lines being built are: Beijing-Shenyang-Harbin (4,200 km), Beijing-Zhengzhou-Wuhan-Guangzhou (2,700 km), Guangzhou-Fuzhou-Shanghai (2,500 km), Nanjing-Tianjin (1,037 km), and Nanjing-Shanghai (450 km). In the second level of this Eighth Five-Year Plan project, fiber optic cable and digital microwave lines will gradually replace overhead lines in the provinces and counties.

First Domestically Made Composite Optical Cable System

91P60172D Xian SHAANXI RIBAO in Chinese 2 Apr 91 p 1

[Article by Li Dexiang [2621 1795 4382] and Xing Chuhua [5887 4342 5478]: "First Domestically Made Composite Fiber Optic Cable Communications System Developed"]

[Summary] The nation's first independently designed and developed composite fiber optic cable communications system, jointly developed by the Baoji Power Bureau, the Northwest Electric Power Design Institute, and the Shanghai Fiber Optic Communications Co., passed acceptance check on 27 March in Baoji. A representative from the State Council's Office for Promotion and Application of Electronic Information Systems issued the certificate of acceptance. This 5-km-long system, constructed alongside Baoji's municipal 110-kilovolt overhead transmission line and intended for automatic power distribution and scientific monitoring of the power grid, has been in trial operation since 1988.

Domestically Developed DS5 Optical Communications System

91P60182A Beijing KEJI RIBAO [SCIENCE AND TECHNOLOGY DAILY] in Chinese 12 Apr 91 p 2

[Article by You Xin [1429 2450] and Yan Xin [4282 0207]: "State-of-the-Art DS5 Optical Communications System Developed"]

[Summary] A 622 Mbit/s digital multiplexing equipment set for a DS5 optical communications system, developed by MPT's Institute 5 as a State Seventh Five-Year Plan priority S&T project, has passed its technical appraisal.

The new equipment, which complies with relevant specifications of the synchronous optical digital series STM₄, a set of standards advanced by the International Telecommunications Union in the late eighties, consists of an optical transmitter/receiver which can carry 7,680 simultaneous voice circuits over a pair of optical fibers. This equipment is an important element for the further domestic development of high-bit-rate, high-capacity digital fiber optic communications during the current Eighth Five-Year Plan.

Five Achievements From Beijing P&T Institute Pass Appraisal

91P60182B Beijing BEIJING KEJI BAO [BEIJING SCIENCE AND TECHNOLOGY NEWS] in Chinese 13 Apr 91 p 1

[Article by Li Jianguo [2621 1696 0948]: "Five Scientific Research Achievements of Beijing Institute of Posts & Telecommunications Pass Appraisal"]

[Summary] Five projects undertaken by the Beijing Institute of Posts & Telecommunications (BIPT)—including four State Seventh Five-Year Plan priority S&T projects such as the "thin-thick-film hybrid integrated optical repeater" and the "experimental 1,500-nm FSK [frequency shift keying] coherent fiber-optic communications system," as well as one project supported by the National Natural Science Foundation (NSFC)—recently passed the S&T achievement appraisal organized by MPT.

The BIPT-developed hybrid integrated optical repeater is a complete optical regenerative repeater for 34 Mbit/s [DS3] and 140 Mbit/s [DS4] digital optical communications systems, and meets mid-eighties international standards. The next project, the experimental coherent fiber-optic communications technology, includes the institute's realization during the recently concluded Seventh Five-Year Plan of a successful 140 Mbit/s 1,500-nm-wavelength FSK system incorporating domestically made laser diodes and other domestically made components (some developed specifically for the project) throughout; this achievement, which approaches mid-eighties international standards, will form an important foundation for further domestic development of coherent fiber optic communications during the current five-year plan. Another achievement involves BIPT's realization of the first domestically developed laser-diode-based fiber-optic-type optical-frequency phase-locked loop, a technology matching mid-eighties international standards. Another domestic "first" for BIPT is its development of a 1,500-nm-wavelength FSK optical cavity frequency-discrimination dual-channel FDM [frequency division multiplexing] experimental/demonstrator system, a major contribution to the domestic development of photonic switching and FDM fiber optic networks. Finally, the NSFC-supported project involves BIPT's development of the model GEC1300-1500 long-wavelength grating external-cavity single-frequency tunable semiconductor laser; with its

narrow linewidth, high side-mode suppression ratio, wide tuning range, and low frequency drift, this laser diode meets mid-to-late eighties international standards.

High-Speed InGaAsP/InP LED Developed for Broadband Loops

91P60182C Beijing BANDAOTI XUEBAO [CHINESE JOURNAL OF SEMICONDUCTORS] in Chinese Vol 12 No 5, May 91 pp 304-308

[Article by Guo Kangjin [6753 1660 3866], Xiao Deyuan [5135 1795 0337], et al. of the Shanghai Institute of Metallurgy, CAS, Shanghai, 200233: "High-Speed 1.3 μm InGaAsP/InP DH LED for Broadband Fiber Optic Subscriber Loops"; MS received 17 Jun 90, revised 5 Aug 90]

[Summary] The first domestic development of a high-speed 1.3 μm -wavelength InGaAsP/InP double-heterojunction (DH) LED with an integrated InP lens is reported. The LED, fabricated via an ion-beam milling technique, has a 3 dB modulation bandwidth of 425 MHz (measured with a 150 mA DC bias) and a coupling efficiency of 7.5 percent into graded-index multimode optical fiber. This LED is intended for incorporation into DS4 and DS5 broadband fiber optic subscriber loops and broadband ISDNs.

The device consists of the following four layers (see accompanying schematic diagram) grown via a two-solution liquid-phase epitaxy technique onto an InP substrate doped with S(100) crystal: an 8 μm -thick Te-doped n-type InP buffer layer, a 0.3 μm -thick P-type InGaAsP active layer, a 1 μm -thick p-type InP confinement layer, and a 0.8 μm -thick p-type InGaAsP cap layer (the p-type dopant is Zn).

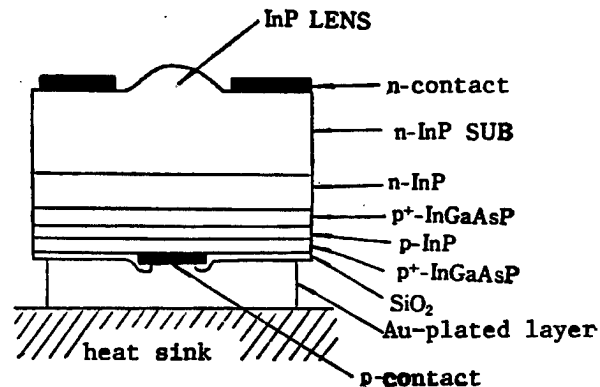

Figure 1. Schematic Diagram of High-Speed LED

Testing reveals that the device has a 100 mA forward voltage drop of about 1.5 V, a reverse breakdown voltage of over 4 V, a launched output power of 17.8 μW , and a spectral half-width (FWHM) of under 100 nm.

**Holographic Gratings Fabricated on InGaAsP/InP
DFB Lasers**

91P60182D Beijing BANDAOTI XUEBAO [CHINESE
JOURNAL OF SEMICONDUCTORS] in Chinese
Vol 12 No 5, May 91 pp 309-312

[Article by Miao Yubo [4924 5148 0590], Zhang Jingyuan [1728 7234 1254], and Wang Wei [3769 0962] of the Institute of Semiconductors, CAS, Beijing, 100083: "Holographic Quarter-Wave Phase-Shifted Gratings for 1.55 μm InGaAsP/InP DFB Lasers"; MS received 18 Jun 90, revised 14 Aug 90]

[Summary] Using a second-order holographic-exposure technique, quarter-wavelength phase-shifted gratings have been fabricated on InP and InGaAsP materials for incorporation into 1.55 μm -wavelength InGaAsP/InP distributed-feedback (DFB) laser diodes, key light sources for long-range high-capacity fiber optic communications systems. The exposure source is a He-Cd laser with a 3,250-angstrom output wavelength. The second-order grating has a period of 4,600 angstroms and was fabricated with the aid of an AZ1350 photoresist mask and reactive ion etching.

**Hybrid Fusion-Fission Reactor Project Passes
Expert Appraisal**

91P60183A Beijing ZHONGGUO KEXUE BAO
[CHINESE SCIENCE NEWS] in Chinese 26 Feb 91 p 1

[Article by Deng Xianchun [6772 6343 2504]: "Overcoming Difficulties of Research on Fusion-Fission Hybrid Reactor"]

[Summary] Chengdu—The "fusion-fission hybrid reactor research" program—a State High-Tech project being undertaken by over 350 researchers from 13 units including the CAS Hefei Institute of Plasma Physics, the Ministry of Nuclear Industry's Southwest Institute of Physics, the China Academy of Engineering Physics, and the China Institute of Nuclear Power Research and Design—has realized several world-class achievements.

Nine of the project tasks and sub-tasks recently passed expert evaluation and appraisal in Chengdu.

After several years of effort, the neutron integrating experiments, the reactor-core pellet feed and ash-removal mechanisms, the low-clutter drive, the tritium multiplier and tritium fabrication research, research on primary-wall materials, conceptual design, ion cyclotron resonance-wave heating and other studies have all produced results. These achievements have been discussed at national and international conferences and almost 100 scientific papers have been published in international journals (almost 1,000 in domestic journals). Three of the achievements have entered the international arena—the Soviet Union, the United States, and China are jointly researching and developing the technologies—indicating that China's research on hybrid reactors is at a world-class level.

NTIS
ATTN: PROCESS 103
5285 PORT ROYAL RD
SPRINGFIELD, VA

22161

2

This is a U.S. Government publication. Its contents in no way represent the policies, views, or attitudes of the U.S. Government. Users of this publication may cite FBIS or JPRS provided they do so in a manner clearly identifying them as the secondary source.

Foreign Broadcast Information Service (FBIS) and Joint Publications Research Service (JPRS) publications contain political, military, economic, environmental, and sociological news, commentary, and other information, as well as scientific and technical data and reports. All information has been obtained from foreign radio and television broadcasts, news agency transmissions, newspapers, books, and periodicals. Items generally are processed from the first or best available sources. It should not be inferred that they have been disseminated only in the medium, in the language, or to the area indicated. Items from foreign language sources are translated; those from English-language sources are transcribed. Except for excluding certain diacritics, FBIS renders personal and place-names in accordance with the romanization systems approved for U.S. Government publications by the U.S. Board of Geographic Names.

Headlines, editorial reports, and material enclosed in brackets [] are supplied by FBIS/JPRS. Processing indicators such as [Text] or [Excerpts] in the first line of each item indicate how the information was processed from the original. Unfamiliar names rendered phonetically are enclosed in parentheses. Words or names preceded by a question mark and enclosed in parentheses were not clear from the original source but have been supplied as appropriate to the context. Other unattributed parenthetical notes within the body of an item originate with the source. Times within items are as given by the source. Passages in boldface or italics are as published.

SUBSCRIPTION/PROCUREMENT INFORMATION

The FBIS DAILY REPORT contains current news and information and is published Monday through Friday in eight volumes: China, East Europe, Soviet Union, East Asia, Near East & South Asia, Sub-Saharan Africa, Latin America, and West Europe. Supplements to the DAILY REPORTs may also be available periodically and will be distributed to regular DAILY REPORT subscribers. JPRS publications, which include approximately 50 regional, worldwide, and topical reports, generally contain less time-sensitive information and are published periodically.

Current DAILY REPORTs and JPRS publications are listed in *Government Reports Announcements* issued semimonthly by the National Technical Information Service (NTIS), 5285 Port Royal Road, Springfield, Virginia 22161 and the *Monthly Catalog of U.S. Government Publications* issued by the Superintendent of Documents, U.S. Government Printing Office, Washington, D.C. 20402.

The public may subscribe to either hardcover or microfiche versions of the DAILY REPORTs and JPRS publications through NTIS at the above address or by calling (703) 487-4630. Subscription rates will be

provided by NTIS upon request. Subscriptions are available outside the United States from NTIS or appointed foreign dealers. New subscribers should expect a 30-day delay in receipt of the first issue.

U.S. Government offices may obtain subscriptions to the DAILY REPORTs or JPRS publications (hardcover or microfiche) at no charge through their sponsoring organizations. For additional information or assistance, call FBIS, (202) 338-6735, or write to P.O. Box 2604, Washington, D.C. 20013. Department of Defense consumers are required to submit requests through appropriate command validation channels to DIA, RTS-2C, Washington, D.C. 20301. (Telephone: (202) 373-3771, Autovon: 243-3771.)

Back issues or single copies of the DAILY REPORTs and JPRS publications are not available. Both the DAILY REPORTs and the JPRS publications are on file for public reference at the Library of Congress and at many Federal Depository Libraries. Reference copies may also be seen at many public and university libraries throughout the United States.