

OTS: 60-11,676

RECENT DEVELOPMENTS IN METAL-
LURGICAL INDUSTRY IN COMMUNIST CHINA

DISTRIBUTION STATEMENT A

Approved for public release
Distribution Unlimited

MAIN FILE

Reproduced From
Best Available Copy

19981203 103

Distributed by:

OFFICE OF TECHNICAL SERVICES
U. S. DEPARTMENT OF COMMERCE
WASHINGTON 25, D. C.

~~Price: \$2.50~~

U. S. JOINT PUBLICATIONS RESEARCH SERVICE
205 EAST 42nd STREET, SUITE 300
NEW YORK 17, N. Y.

JPRS: 2717

CSO: 3984-N MAIN FILE

RECENT DEVELOPMENTS IN METALLURGICAL
INDUSTRY IN COMMUNIST CHINA

The following are translations and extracts of selected articles from Yeh-chin Pao (Metallurgical Journal), Peiping, issues No. 31, 44, 47, 48, 49 and 51, 1959.⁷

TABLE OF CONTENTS

<u>Article</u>	<u>Page</u>
LET MECHANIZED POWER EQUIPMENT BE NORMALLY OPERATED	1
COAL WASHING IS AN IMPORTANT LINK TO THE COKE CONSERVATION CHAIN	5
HSIANG-SHAN IRON MINE DEVELOPED IN THE COURSE OF THE BIG LEAP FORWARD	17
A GOOD DESIGN COMBINING MODERN WITH NATIVE METHODS	19
IMPORTANT MEASURE FOR INCREASE OF PRODUCTION FROM OPEN HEARTH FURNACES	20
RAISE HIGH THE "MULTI-BAR RAPID-ROLLING" RED BANNER AND MARCH FORWARD	29
VIGOROUSLY DEVELOP TECHNOLOGICAL REVOLUTION, INTENSIFY WORKING OF NON-FERROUS MINERALS	37
CURRENT TASKS IN CAPITAL CONSTRUCTION	45
OVERALL BIG LEAP FORWARD IN METALLURGICAL CONSTRUCTION	51
MINES SERVING OPEN HEARTH FURNACES MUST CONTINUE THE BIG LEAP FORWARD IN 1960	53
SMALL-SCALE IRON AND STEEL INTEGRATED ENTERPRISES HAVE DONE MANY THINGS FOR RURAL AREAS DURING GREAT LEAP FORWARD	57
"ALL RED OVER" IN SMALL BLAST FURNACES IN YUNNAN	67

<u>ARTICLE</u>	<u>PAGE</u>
GREAT FUTURE AHEAD OF CONVERTER STEEL FURNACES ...	70
HUBEI PROVINCE ENERGETICALLY DEVELOPS NON-FERROUS METALS INDUSTRY	83
SZECHUAN COPPER, LEAD AND ZINC OUTPUT INCREASES .	85
SHENYANG ACHIEVES DOUBLE LEAP FORWARD IN OUTPUT AND QUALITY OF NON-FERROUS METALS:	88
DIFFICULTIES OVERCOME IN CONSTRUCTION OF TANGSHAN ALUMINUM PLANT	89
PREPARE WELL FOR THE "RED ALL OVER" AT THE VERY START OF 1960 IN NON-FERROUS METALS INDUSTRY ...	93
AUXILIARY MATERIALS MINES MUST ALSO CONTINUE GREAT LEAP FORWARD	95
NON-FERROUS SMALL MODERN PLANTS ARE FLOURISHING .	97
METHODS OF CALCULATING THE MAJOR TECHNICAL AND ECONOMIC TARGETS OF OPEN HEARTH FURNACE	100

LET MECHANIZED POWER EQUIPMENT BE NORMALLY OPERATED

The following is a translation of extracts from an editorial in Yeh-chin Pao (Metallurgical Journal), No. 31, Peiping, 31 July 1959, pages 3-4.7

In order to fully develop the productivity of the metallurgical industry and to guarantee the continued leap forward in production, an urgent and important problem which faces leadership departments at all levels is the strengthening of the maintenance and repair of equipment, to ensure the production and supply of spare parts and accessories, so that mechanized equipment may be operated normally. "If the craftsman is to perform his job properly, he must first maintain his tools in good repair." The condition of equipment is therefore of the utmost importance.

Since 1958, under the illumination of the general policy for the exertion of the utmost effort, pressing forward consistently, and building socialism with greater, faster, better and more economical achievements, we have scored great results in our work connected with mechanized power in the metallurgical industrial system. Iron and steel production doubled that of the preceding year of 1957. The efficiency of existing production equipment was greatly raised, and this could not be separated from the efforts of workers connected with mechanized power.

With the great development of the metallurgical industry, the amount of equipment in the industry greatly increased, and

this brought about the unprecedented aggravation of the task of the maintenance and repair of equipment, and the manufacture of spare parts and accessories. Under the situation in which our repairing capacity was not fully adequate, the whole body of workers in the mechanized power sections devised all ways and means, exerted self efforts for rejuvenation, overcame difficulties and thus fulfilled in an outstanding manner many heavy tasks in the maintenance and repair of equipment, to guarantee the big leap forward of the metallurgical industry, particularly the iron and steel industry.

However, we must also realize that our current task in the mechanized power field is still inadequate to meet the demands of the big leap forward in production. This situation is revealed, in a concentrated manner, in three directions: abundance of accidents involving equipment; serious damage to equipment; and low rate of turnover in operation. Though all these are but individual defects in the midst of the great development of production, the problems are nevertheless serious. If the situation is not immediately switched around, we shall face great difficulties in seeking safety in production.

The objective cause is principally the fact that while production has developed, mechanized power has not caught up with it correspondingly. For example, the processing capacity of lathes now in use is only sufficient to meet one third of the need for spare parts. However, viewing the situation subjectively,

we had underestimated the situation of mechanized power that began to confront us. At an earlier period, the leadership concentrated all major efforts in production, and did not pay sufficient attention to the maintenance and repair of equipment and the state of its operation. In some enterprises, the machinery repair plant undertook mainly the manufacture of equipment and reduced the output of spare parts and accessories. This led to the situation of a serious lack of the supply of spare parts.

There are also quite a number of units where nobody held the responsibility for work in the mechanized power section. The necessary regulations and systems were not established and perfected. All this led to the situation in which the maintenance, inspection and repair of equipment lagged behind the development of production.

During the second half of 1959, we must switch around the situation of the frequent incidence of accidents involving equipment, serious damage to equipment, and the low rate of operation of equipment if we are to guarantee the continual rise in production levels. For this, workers connected with mechanized equipment in the metallurgical industrial system must exert greater efforts, on the foundation of past achievements, to earnestly strengthen measures for the maintenance of equipment, and vigorously organize the supply of spare parts and accessories.

1. We must strengthen the maintenance, protection, inspection and repair of equipment. In this task, all enterprises must thoroughly implement the policy of "looking after prevention first, and strengthening planned inspection and repair measures."

2. We must rationally arrange for the production and supply of spare parts and accessories. Spare parts and accessories constitute the foundation for the proper handling of maintenance and repair. Without an adequate supply of spare parts and accessories, maintenance and repair cannot be carried out normally. At this moment, the correct path to the solution of the problem is the proper organization of existing mechanized forces to produce more and better spare parts and accessories.

3. We must guarantee the supply of power. In modern industry, we cannot be cut off for a single moment from power generated by water, wind, electricity or gas. To meet the needs of production development in the metallurgical industry, all power supply systems of the industry must raise their output under the condition of guaranteeing the operation of their equipment with safety. At the same time, we must also pay attention to the economy of power and reduce consumption norms.

COAL WASHING IS AN IMPORTANT LINK TO THE
COKE CONSERVATION CHAIN

[This is a full translation of an article on coal washing operations in Wusih Municipality, published, with an introduction by the editor, in Yeh-chin Pao (Metallurgical Journal), No. 31, Peiping, 31 July 1959, pages 28-30, and 37.]

[Yeh-chin Pao editor's comment]

Study from Wusih Municipality

- Use Minimum Coal for Greater Output of Iron -

In the operation of blast furnaces, economy of coke through the reduction of the ratio of coke consumption is to a very great extent decided by the quality of the coke. The first obstacle to be overcome in raising the quality of coke is coal washing. In Wusih Municipality, Kiangsu Province, two coke plants use a combination of native and modern methods to produce successfully a simple leaping type coal washing machine, and the quality of washing carried out approaches that of large coal washing plants. With the improvement of the quality of washing, and with the mineral deposits having a 40 percent mineral content, the ratio between iron and coke is maintained at the approximate level of from 1:2 to 1:3. A record was created in the use of three tons of coal for refining one ton of iron.

Wusih municipality resorted to all ways and means to manufacture the coal washing machine for the thorough implementation of the spirit of putting into the furnace only coal which has been

washed. This practice deserves emulation by all. To solve such problems as materials for the equipment of the coal washing machine, the increase of output and the economy of manpower, Wusih Municipality studied the superior features of the coal washing machines in the Hsueh-ch'eng Coke Plant in Shaantung; the Tangshan Coke Plant; and the Woosung Gas Plant in Shanghai. Combining their special features with conditions in the local units, Wusih developed a new machine. It was built with only 3.2 tons of steel, and is operated by 40 productive personnel, so that a great step has been taken toward the solution of the problem of producing coal washing equipment and that of the lack of manpower. The experience of Wusih shows that we can overcome the difficulties presented by these two problems.

The economy of coke is a major content of the movement for production increase and economy during the second half of 1959. All localities and all enterprises should earnestly study the experience of Wusih, undertake the task of coal washing earnestly, so as to raise the quality of coke and thus reduce the ration of coke used.

The article

The two coke plants in Wusih Municipality, the Ku-hsin and Wu-shih, studied the experiences of coal washing equipment in Tangshan, Shantung and Shanghai, and in combination with their own concrete conditions, manufactured successfully the simple leaping

type coal washing machine. The machine calls for a small investment, is built rapidly, and is very effective. The cost of one machine is about 23,000 yuan, and it uses only 3.2 tons of steel. The machine treats from 25 to 35 tons of coal each hour.

At present, the two plants in Wusih together have four of these machines, and each month they handle about 48,000 tons of coal which yield about 34,000 tons of fine coal. The rate of the acquisition of washed coal varies according to the quality of the coal, and generally from 65 to 85 percent of the original quantity is obtained. After washing, the ash content in the coal is reduced generally by about 50 percent, approaching the quality achieved in the large washing plants. With the rise of the quality of washing, the quality of the coke is stabilized, and the ratio of coke used is maintained at the level of from 1:2 to 1:3. A record was created of refining one ton of iron with three tons of coal, thus greatly reducing the production cost of iron.

We describe below the structure of the coal washing machine and its operational conditions:

Structure and Installation of Coal Washing Machine

I. Locomotive Section. This section includes the transmission belt, the vibration sieve, the large crystal crushing machine and the elevator. The holes of the vibration sieve have a diameter of 37 millimeters. The large crystal crushing machine makes use of a small hammer type pulverizer, installed

at the outlet of the sieve, so that crystals larger than 37 millimeters automatically pass into the crushing machine to be broken up. The speed of the sieve is from 600 to 700 revolutions per minute. Better results are obtained with greater speed, for if the speed is slowed down, medium size and small crystals may block the holes of the sieve. The use of the vibration sieve to replace manual sieving operations has raised efficiency five or six times, and the coal crystals are fairly even in size.

II. Main Body of Machine. This section is made up of such equipment as eccentric wheel, shaft, wooden washing box, and sieve. The washing box has a volume of seven cubic meters. Originally, the movement of the respiratory plate in the corked cleansing department was worked with two eccentric wheels pulling one respiratory plate, the oblong washing box being divided into two cleansing compartments. This made the rod easily broken, and air leaks. Later the respiratory plates were increased to four, and the two cleansing compartments made into four. This has brought greater stability to the movement of the plates, the rubber stoppers around the plates sealed the compartments tightly and suction power was increased.

Originally, manual labor was used to seek out and remove rocks, but this process has since been semi-automatized, as follows:

- (1) The outlet of the coal washing sieve is bent upward

80 millimeters. so that the plate of the sieve is separated from the water compartment, and rocks are automatically driven out through the vacant space. The end of the sieve is bent upward 80 millimeters to prevent the outflow of the mineral deposits at the bottom of the sieve.

(2) The stopper hole at the bottom of the compartment for the outflow of rocks is enlarged so that the largest rocks may flow out.

(3) Above the vacant space of the sieve plant, there is added a control plat to control the volume of rocks driven out.

In this way, the quality of coal washing has been greatly raised. At the point of the outlet of dehydrated coal, water sprayers are installed to cleanse the coal crystals of mud sticking to them, to reduce the ash content of the coal.

III. Power and Water Supply Equipment

(1) On the basis of practical operation, one coal washing machine only needs a 14-kilowatt motor. However, if several smaller motors are used instead, the separate motivation of different parts of the equipment will be the more rational.

(2) Generally, from five to six tons of water are needed for washing one ton of coal. Thus for each coal washing machine we may install iron cast pipes of 100 millimeters diameter. But there must be two water supply sources, one as the reserve supply.

(3) After coal has been dehydrated, a large quantity of coal dust water and coal dust is left behind (about 20 percent.)

Plan of Installation of Coal Washing Machine

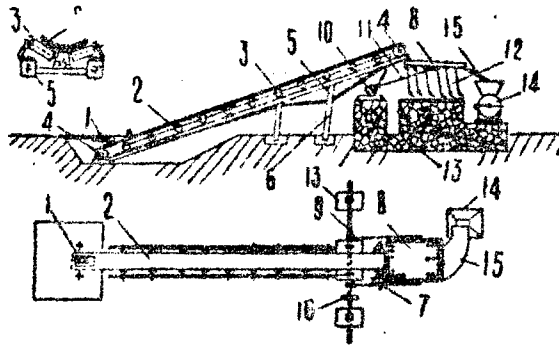

1. point of entry of raw coal; 2. transmission belt;
3. pulley for sleepers under transmission belt; 4. transmission belt cylinder; 5. wooden frame for transmitter;
6. support for wooden frame; 7. belt pulley for transmitter;
8. vibration sieve; 9. shaft of vibration sieve;
10. eccentric shaft cover for vibration sieve;
11. eccentric rod of vibration sieve; 12. bamboo support for vibration sieve; 13. cement concrete base;
14. hammer type crushing machine; 15. outer plate for vibration sieve; and 16. belt cylinder for vibration sieve.

Coal dust is treated with a precipitation tank constructed with bricks superimposed with cement. Generally each washing machine has to be served by from six to eight precipitation tanks the use of which is regulated. The coal dust water from the last precipitation tank may be brought back to the machine for the

washing of coal.

(4) Two precipitation tanks are also needed for the regulated treatment of rocks in the coal washing compartment and the diluted water from the intermediary coal, and small crystals of intermediary coal are to be recalled.

(5) For the dehydration of refined coal, the iron plated sieves in use by rice mills or flour mills can be used.

Production Process

The production process of coal washing is as follows. The raw coal is transported to the transmitter, and goes through the selective process of the vibration sieve, hand picked rocks, and reduced to smaller sizes. It is then sent by the elevator to the washing machine. After rinsing and separation, the rough surfaces and coal dust are removed, and this refined coal is the major product of coal washing. Next comes the treatment of rocks, rock fragments, coarse intermediate coal, fine intermediate coal, and coal dust. They may be taken out at different sections of the plant.

Through this process, raw coal may be sent into the vibration sieve evenly, so that the crystals are maintained at the size of less than 35 millimeters. Because the crushing machine for large crystals is by the side of the vibration sieve, the large pieces on the sieve can automatically flow into the crushing machine. After crushing, the crystals will be similar to those at the bottom of the sieve and be mixed with them. The elevator sends

Chart showing sewers and precipitation tanks of coal washing machine

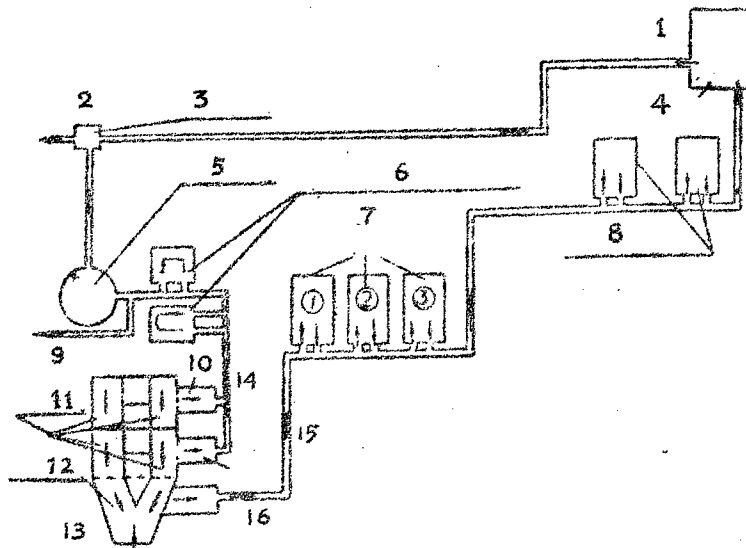

1. outlet of clean water after precipitation.
2. entry of dirty water into sewer
3. open well
4. final precipitation tank
5. well receiving water used
6. precipitation tank for intermediary coal and dirty water
7. precipitation tank for coal dust 2.5 x 3.5 x 1.5
8. precipitation tank for coal dust
9. entry to sewer
10. mineral deposits
11. coal washing box
12. sewer for intermediary coal and mineral rocks.
13. dehydration sieve
14. intermediary coal
15. precipitation sewer
16. entry of coal dust water

the coal in the sieve to the washing machine for selection and washing, after the crystals have been evenly distributed. All this guarantees the improvement of the quality of washing.

The quality of coke is greatly affected by the proper handling of raw coal and refined coal, and the strengthening of coal washing technique. After a period of groping after experiences, we have summed up the following necessary steps.

I. Worksite Management

(1) Management of raw coal stockyards. In a stockyard for raw coal, supplies must be piled up separately according to the types of coal, their names must be posted for identification. A stockyard for raw coal is not suited for the storage of other materials, and cleanliness must be maintained.

Before raw coal is sent to a plant for treatment, samples must be taken for analysis. New types of coal must especially be analyzed in time and mixed supplies must be prevented. In order to facilitate the washing of coal, we must be acquainted with its special characteristics, and before coal is sent for washing, a selective test of a simple nature may be carried out, and on the basis of its quality, the quantity of coal for washing at a time must be determined as well as the number of times the process of rock removal.

(2) Management of stockyard for refined coal. This is even more important. If this is not properly managed, mixed substances may get into the coal, increasing its ash content.

Stockyards for refined coal must have brick floors, and the middle of the floor must be higher than the sides so that the coal may release its water content. If the types of coal are more complicated and assorted types have to be taken care of, the stocks must be placed in separate piles according to the types, and assortments prepared later.

II. Management of Sewers and Tanks

Whether or not the sewers and precipitation tanks in coal washing are properly managed affects the quality of the refined coal and damage and loss. The sewers must be kept in a good state of flow. When a tank is filled with coal to the extent of 80 percent of the volume, the coal must be taken out.

III. Strengthening of Analytical Work

The two coke plants in Wusih carry out the following analytical tasks: analysis of selectivity of raw coal; industrial analysis of refined coal; and a material equilibrium test and complete test analysis at fixed intervals. The actual figures thus collected are used to guide production, so as to achieve unanimity between the subjective and the objective. The results of coal washing are raised, and good quality metallurgical coke is obtained.

IV. The Formulation of Work Rules

Different work rules are formulated on the basis of the special characteristics of different types of coal. The rules are summed up in the four characters: evenness, diligence,

fixedness, and flexibility.

(1) Evenness calls for even crystals of raw coal sent in for washing, generally below 35 millimeters. Thus before washing, we must carry out the crushing and sieving processes. The material selected must be even, and not vary at different times. When the load is too great, the ash content of the coal will be increased. When the load is too small, the output will be reduced.

The watering of the coal must be carried out evenly, so that the fluid is stable. Too much water may cause large quantities of rocks or intermediary coal to get into the refined coal and affect the quality of the coke. Too little water will lead to less marked results in separation in the rinsing process.

The number of times water is poured must be even, so that the coal may proceed in a regular crooked line inside the rinsing machine, to raise the effects of selection and washing. Otherwise the quantity and quality of output will be affected.

(2) Diligence generally includes diligence in taking out the rocks, diligence in agitating the precipitation tanks, so that coal dust precipitation is good and the quality of coal dust is raised; There must also be diligence in the inspection of the thickness of the layers of coal (using an iron pike or a wooden rod), generally maintaining the thickness of 150 millimeters in the front box, and 200 millimeters in the rear box. If the

layer is too thick, the rocks will be taken into the coal. And if the layer is too thin, the fine coal will get into the rocks or intermediary coal. We must also be diligent in experiments (floatation experiments) to determine the situation relating to the washing and selection of finecoal, rocks and intermediary coal.

(3) Fixation includes the fixing of work posts, the fixing of the number of times of watering, and the fixing of the speed of the motor. Except in cases of special changes in the type of coal treated, generally no changes should be arbitrarily made of decisions reached.

(4) Flexibility calls for the consideration of the special quality of coal in making timely decisions for the flexible control and correction of operations. For example, if there is an abundance of coal dust, the number of times of watering must be increased, and contrariwise, it must be reduced. If the ash content of raw coal is high, the layer may be reduced in thickness, and less effort taken in the removal of rocks. Contrariwise, the removal of rocks may be increased. At the same time we must have flexibility in the sending of coal loads for washing, as good coal may be handled in larger quantities and inferior coal must be handled in smaller quantities.

HSIANG-SHAN IRON MINE DEVELOPED IN THE
COURSE OF THE BIG LEAP FORWARD

✓The following is a translation of an extract of an article by WANG K'o-hsueh, secretary of the Party committee of Hsiang-shan Iron Mine in Chefoo, Shantung, in Yeh-chin Pao (Metallurgical Journal), No. 44, Peiping, 6 November 1959, page 47.]

The Hsiang-shan Iron Mine in Chefoo, Shantung, was started in April 1958. At the time only a few cadres led 17 workers who undertook prospecting side by side of production. Iron hammers and pikes were used in developing the deposits, and hand pushed carts were used in transportation. Irregular open cast native methods were adopted in working the iron deposits, and production efficiency was low.

Following the extensive development of the mass movement for the vigorous development of the iron and steel industry, the mine grew rapidly. By the end of 1958, there were more than 2,300 workers. During the period from April through the end of 1958, 58,127 tons of iron deposits were developed, and 20,805 tons of iron ore were washed. This supported the big leap forward in iron and steel production in 1958.

Since 1959, under the illumination of the general line, and on the foundation of the summarization of the experiences of the 1958 big leap forward, in order to realize the proposal of the Central Committee of the Party for the glorious task of producing 12 million tons of steel, the Party committee of the mine took

into account the key problems of inferior tools and equipment, heavy physical exertion and low productivity, and mobilized the workers for the vigorous promotion of the technological revolution and technical reform, and earnestly implemented the policy of paying prior attention to native methods before modern methods, and combining native methods with modern methods.

In the course of reform, everybody used his head, and everybody had a hand in reform. By August 1959, the mine used native methods to manufacture 41 kinds of new tools, aggregating more than 400 pieces; so that more than 90 percent of the workers put down weight carrying poles and baskets, handcarts, hand hammers and other heavy tools, to realize the native mechanization of operations. This greatly reduced physical exertion and raised labor productivity. With the reduction of personnel by 34 percent, the daily output of iron rose from about 50 tons to the highest level of 508.5 tons reported on 22 September 1959.

The actual total output for January through August 1959 was 42,704 tons, being 105.89 percent of the planned target. The quality was all above the 40 percent level. Labor attendance rate averaged 98.59 percent, exceeding the original demand for 95 percent. Production cost also dropped from an average of 21.4 yuan per ton of mineral during the first quarter to 10.4 yuan during the second quarter, a drop of 51.15 percent. The mine victoriously fulfilled the various tasks entrusted it by the Party.

A GOOD DESIGN COMBINING MODERN WITH NATIVE METHODS

- advanced achievement of 76-millimeter diameter
seamless tube plant designing team of Ferrous
Metals Metallurgical Designing General Bureau -

/The following is a translation of an extract in an article
in Yeh-ching Pao (Metallurgical Journal), No. 44, Peiping,
6 November 1959, page 50./

During March and April 1958, the Ferrous Metals Metallur-
gical Designing General Bureau of the Ministry of Metallurgical
Industry used only the short period of one and a half months to
produce a complete set of designs for a small seamless steel tube
plant combining the use of modern methods with that of native
methods.

The plant annually produces from 10,000 to 15,000 tons of
seamless steel tubes with diameters ranging from 10 millimeters
to 76 millimeters. The equipment of the whole plant is compara-
tively simple, and its total weight does not exceed 150 tons.
The entire equipment can be manufactured by a normal machine
building plant in China. The total investment in capital con-
struction is only between 700,000 and 800,000 yuan. Only a period
of from four to five months is required for the entire process of
the manufacture of equipment, the construction of the plant, the
installation of equipment and the commencement of production.
It has such advantages as small investment, high output, good
quality of products, and simplicity of operation and equipment.
Accordingly the design has rapidly been adopted all over the country.

IMPORTANT MEASURE FOR INCREASE OF PRODUCTION
FROM OPEN HEARTH FURNACES

/The following is a translation of extracts from an article in Yeh-chin Pao (Metallurgical Journal) No. 44, Peiping, 6 November 1959, pages 62-64./

At the moment, in the struggle for the advanced overfulfillment of the output of 12 million tons of steel, the output from open-hearth furnaces is to constitute more than 50 percent of the total output of steel. The open-hearth furnaces make up the main army. A current urgent task is, therefore, how we may develop the prowess of the open-hearth furnaces.

During the past ten years, steel refining in open-hearth furnaces developed at a high speed. In the metallurgical departments, the open-hearth furnace utilization coefficient in 1949 was only 3.11 tons. Today it has been raised to 7.78 tons. It is anticipated that at the end of 1959 the open-hearth furnace utilization coefficient will exceed 9 tons, while that of large open-hearth furnaces will exceed 10 tons, and that of advanced small open-hearth furnaces will exceed 16 tons. Today, 80 percent of steel refining in open-hearth furnaces is carried out in open-hearth furnaces with alkali roofs. The open-hearth furnaces of China are now capable of refining all kinds of steel which can be turned out from open hearth furnaces in the world.

What is the enlarged volume of a furnace? This signifies the

feeding of more materials into the furnace and the realization of greater output through the continual improvement of the structure of the furnace and the suction system. The provision of more troughs and more pitchers means that the increased liquid steel produced is led through two-forked or three-forked troughs to two or three pitchers to hold the steel, and originally provided cast iron elevator or increased elevators of similar size are used to hoist the steel liquid which is poured and processed into steel ingots.

Take for instance the newly constructed 100-ton permanent type open hearth furnace. If we adopt the design of a single trough and a single pitcher, the cast iron elevator will have to bear the load of 150 tons, and the load of the structure of the plant will have to be correspondingly large. If we adopt the system of two troughs and two pitchers, it will be enough if we have two elevators of 75 tons each, or one 75-ton elevator and one 75-ton watering machine on the ground. If we adopt the system of three troughs and three pitchers, it will be sufficient if we have two 50-ton elevators and one 50-ton watering machine on the ground or one 50-ton elevator and two 50-ton watering machines on the ground.

The same principle can be applied to existing open hearth furnaces already in production. Take the example of a permanent 50-ton open-hearth furnace. If there was originally only one 50-ton elevator, and when the volume of the furnace is expanded to from 130 to 150 tons, there is no need to install a new ele-

vator of about 200 tons. It will be sufficient if we merely add one 75-ton iron cast elevator and one 75-ton watering machine on the ground, or alternately two 75-ton watering machines. The iron cast elevator costs high, and takes a long time to produce, and the larger ones are not produced in quantity in China. The watering machines on ground are simple and easily manufactured, costs little, and are cheap, and so the promotion of the system of multi-troughs and multi-pitchers and the use of watering machines on ground will provide favorable factors for the high speed building of open-hearth furnaces in the future.

In the course of raising the output of open hearth furnaces from low to high levels, we had exerted great efforts to work for the lengthening of the life of the furnaces, the raising of work efficiency, the improvement of operational methods, and the strengthening of the refining process. We also studied many experiences from the Soviet Union. The open hearth furnace utilization efficiency was raised to 6.35 tons in 1955.

On the basis of this comparatively high level, how are we to further raise it? Workers in the field hold different views. Some think that the oxidized refining method must be adopted if we are to produce more steel and more quickly. And when more steel is produced, we must rebuild the plants and increase cast iron elevators of a larger size. This is one view.

It is clear that the rebuilding of plants and the addition of iron cast elevators implies the expenditure of greater capital

and time, and production has to be suspended for a period.

There is the other view. The existing furnace is to have its volume expanded. When a general repair is carried out, the time is utilized for the expansion of its volume on the basis of the original capacity. Cast iron elevators similar in size to the original are added. The advanced experience of two troughs and two pitchers is adopted to achieve the goal of handling more raw materials and producing more steel. This view was rapidly proved the correct one.

As early as in 1954, the Shenyang Heavy Machinery Works used the double-trough double-pitcher method in its open-hearth furnace. But it did not combine this measure with the expansion of the volume of the furnace, the superiority was not revealed. And so it did not attract the attention of workers with the open hearth furnace.

It was not until October 1957 that the Taiyuan Iron and Steel Works, in carrying out the general repair of its No. 3 open hearth furnace, expanded the volume of the furnace, and adopted the method of double trough and double pitcher for producing steel. The volume of steel output quickly increased from 49 tons to 70 tons and then to 95 tons. The output per hour was raised 41 percent. It was then that the prowess of the method was revealed.

In March 1958, on the foundation of the double trough and the same plant double pitcher system, created the method of producing steel with three troughs and three pitchers, and output was further increased

from 95 tons to between 130 and 150 tons.

Later Chungking Steel Works adopted similar measures on similar furnaces and achieved similar results. Anshan Steel Works, in designing its 500-ton furnaces, adopted similar measures, and the output of a furnace reached 660 tons.

The No.3 plant of Shanghai Steel Works adopted the method of producing steel with a single trough served by two pitchers. That is to say, when one pitcher has been filled with liquid steel, the flow continues and the excessive fluid goes to the second pitcher. This also increased the output of a furnace originally designed for 10 tons to be increased to 45 tons.

In addition to the adoption of the basic measure, the Tayeh Steel Works adopted another method of using one trough and two pitchers. The trough is divided into two sections. The section adjacent to the furnace is fixed, with a pitcher underneath. The other section is flexible, also with a pitcher underneath. When steel begins to flow, the two sections are connected. When the pitcher beneath the flexible section is filled, the flexible section is removed, so that the liquid steel flows into the fixed section and its pitcher.

In addition to the above, Chungking Steel Works also experimented on the method of having two liquid steel outlets, one higher and the other lower, supported by two troughs and two pitchers.

In China, the method of using many troughs and many pitchers is rich and varied. The adoption of the multi-trough system has

also produced outstanding results in the expansion of the volume of the collapsible type of large open hearth furnaces. As an example, in Anshan Steel Works, a 100-ton open hearth furnace has had its volume increased to 225 tons, and a 150-ton open hearth furnace has had its volume increased to 300 tons during the big leap forward of 1958.

After the open hearth furnaces have expanded their volume and the method of multi-trough and multi-pitcher has been adopted, we must demand simultaneous attention to such operational methods as the release of liquid iron, the change of pitchers, the production of steel, the production of steel ingots, the placing of the bottom plate, the molding of steel ingots, and the removal of garbage. Within the narrow limits of the ingot casting workshop, if only elevators are used, they will be incapable for the task. Big cranes are expensive and cannot be easily manufactured. If too many elevators are put into service, there will be the result of mutual interference among them.

To spare the iron cast elevators from excessive burdens and to solve the problem of the lack of elevators, and to economize investment and continually unearth the potentials of existing equipment for production, we have opportunely produced the watering machine for use on the ground level.

The ground level watering machine has been created by open hearth furnace workers in accordance with different production conditions. Today, the open hearth furnace workshops in China

are now using eight types of watering machines on the ground level, belonging to three classes under two groups. They are distributed over 11 units.

Different types of ground level watering machines:

1. Machine on a fixed frame.

(The following three types belong to the class of single direction movement.)

2. Single gear single pitcher type.
3. Single gear double pitcher type.
4. Double gear double pitcher type.

(The following four types belong to the class of two direction movement.)

5. Double direction double use type
6. Double direction single use type.
7. Ground level circular movement type.
8. Elevated level circular movement type.

In the construction of ground level watering machines and in their installation in the workshops, the relevant units have made definite improvements and raised their levels of efficiency. As a result, these watering levels have basically achieved the capacity of cast iron elevators.

Moreover, as the increase of the load of a crane calls for the strengthening of the plant, and the addition installation of cranes calls for the expansion of the plant, the use of ground level watering machines, in addition to substituting for

cast iron elevators, is not restricted by the load borne by the plants, and avoids mutual interference among many elevators. This facilitates work in the casting section. The equipment of the ground level watering machines is simple, they can be manufactured quickly and investment needed is small. Thus the superiority of the ground level watering machines is growingly marked.

It can be seen that the continual expansion of the volume of the furnace and the extensive adoption of the multi-trough and multi-pitcher system and the ground level watering machine is a basic measure for the increase of output from an open hearth furnace and the acceleration of the construction of open hearth furnaces. According to a general calculation, if we further develop the role of such a measure, and add certain necessary equipment, it will be possible in 1960 to increase by 2,000 tons the volume of open hearth furnaces in the metallurgical departments, and this is equivalent to the building of five large open hearth furnaces of 500 tons each.

For the large open hearth furnaces newly constructed in steel plants, if the new measures are adopted, a preliminary estimate shows that the load of iron cast elevators can be reduced by from 30 to 60 percent, the load of the structure of the plant can be reduced by from 20 to 30 percent, and the net vacant space inside the plant can also be greatly reduced. Adding together all these factors, a reduction of from 20 to 25 percent in cost can be realized in the steel structure of the plant. The invest-

ment per ton of steel in a workshop for a large 50-ton open hearth furnace will be similar to that in a converter furnace.

However, at present some open hearth furnaces have not yet adopted the new measure. In the designing of new open hearth furnaces, the measure only begins to receive consideration. We hope that workers in this field will continue to achieve ideological liberation, break down superstition, and rapidly summarize and elevate this experience created in China, so that this flower of the technological revolution will blossom all over the country, to play a greater role in the acceleration of the socialist construction.

RAISE HIGH THE "MULTI-BAR RAPID-ROLLING"
RED BANNER AND MARCH FORWARD

The following are extracts from an article in Yeh-chin Pao (Metallurgical Journal), No. 44, Peiping, 6 November 1959, pages 64-66.

The output of steel in 1959 will exceed 12 million tons, an increase of over 50 percent compared with 1958. We can fulfill three years ahead of schedule the 1962 target laid down in the Second Five Year Plan. The output of steel products will see an increase proportionate to that of steel. There will particularly be a high speed development in such categories and types of products as have a direct bearing on the big leap forward in industry, agriculture, and communications and transport, including heavy rails, large size steel products, light rails, seamless tubes, thin plates, and silicon steel sheets.

On the basis of experiences of the past few years, an effective measure to increase the output of steel products is to make use of the newly added productive capacity from capital construction. In 1958 we built several scores of comparatively small steel rolling equipment sets, and in 1959 we have built scores of larger sets of rolling equipment. All these make up a new force in raising the production of the steel rolling industry. On the other hand, we must also fully develop the potentials of existing steel rolling equipment.

In the field of steel rolling, in 1958 we brought into existence many rich and varied production increase measures. These measures may be summed up as the advanced experience of "multi-bar (steel feeding) and rapid (quick) rolling (manufacture)." Except for the small number of steel rolling equipment with a greater degree of mechanization and automation, we have been able to popularize universally this advanced experience among old steel rolling plants generally and newly built steel plants thrown into production. And we have very rapidly raised the output of steel rolling plants to a new level.

"Multi-Bar, Rapid Rolling" is Direction Toward

Increased Production of Steel Products

The "multi-bar rapid rolling" method is a valuable experience created and summed up by China's steel rolling workers and technical personnel during their many years practice in production. Particularly after the big leap forward in 1958, this experience has been perfected, and concrete measures for its popularization have been found for use on different types of steel rolling equipment.

In the initial rolling operation, Anshan Steel created the "double bar rolling method." Originally, after one steel bar had been rolled, the rotor had to be compressed before the next bar of steel can be admitted for treatment. The new method calls for the rolling of two bars before the rotor is compressed. The use of this "double bar rolling method" can raise output by about 14 percent. If the method is used for all products in the plant,

output can be raised by about 40 percent.

On the mold making machine and the molding steel rolling machine, the Molding Steel Workshop of Anshan Steel and the No. 1 Plant of Shanghai Steel created the "criss-cross multi-bar steel feeding method." This method calls for the rolling of several bars with each turnover of the movement of the elevator. At present, in the rolling of heavy rails, from three to four bars may enter the machine at the same time. In the rolling of steel joists, two or three bars may be treated at the same time. In the rolling of small round steel bars, three or four bars may be treated at the same time. In the No. 1 Plant of Shanghai Steel, when the mold making machine makes one turnover up and down the elevator, as many as five bars have been treated.

The realization of the criss-cross multi-bar steel feeding method will greatly raise the output of steel products. For example, in 1959, the output of the large steel rolling machines in Anshan Steel has exceeded the designed capacity by more than three times. In the No. 1 Plant of Shanghai Steel, the rolling capacity of the mold making equipment series No. 630 has increased to nearly double that originally designed.

The realization of the "two-way rolling method" on molding steel rolling machinery can raise output and increase the types of products. The method of "two way rolling" which makes one machine do the work of two has been practiced on medium sized and small machines in the No. 3 Plant of Shanghai Steel, Tangshan

Steel Works, and Tientsin No. 1 Steel Works. Without increasing major equipment, these plants have not only created two production systems with one set of machinery equipment, but also turned out two categories of products at the same time, and furthermore raised output by from 50 to 100 percent.

For use on wiring material machines and small rolling machines, the multi-bar feeding method is principally carried out with the installation of the "multi-trough positive and negative discs." The installation of discs not only raises output, but also eliminates heavy physical exertion involved in the use of manpower for the retrieving of steel. The worker's operational conditions are thus improved.

In Shanghai and Tientsin, after the installation of multi-trough discs on the wiring materials equipment, from three to four bars can be rolled at the same time. In Shenyang, the discs installed have more troughs than originally designed. The design called for the simultaneous rolling of three bars, but it is now planned to roll from five to six bars at the same time. The output is thus expected to be increased by about 70 percent over the designed level. In Shanghai, the installation of discs has been carried out in many small plants manufacturing round and square steel bars, flat steel bars, oval steel bars and angle steel bars, and production has been satisfactory.

The "multi-sheet rolling method" is also practiced on thin steel sheets. As far back as in early 1957, the Anshan Iron and

Steel Company started experiments on "multi-sheet rolling."

The number of sheets rolled at the same time was increased from two to three, and then to four. Output was greatly raised. The Taiyuan Iron and Steel Company adopted the "four-sheet rolling method" in the production of silicon steel sheets on its thin plate machine, and output was raised by 14 percent.

With reference to the rapid rolling method, various plants also created many new measures on the basis of their own concrete conditions. For example, where the principal motor of the rolling equipment and the strength of other equipment permitted, the pressure used was increased, to reduce the number of rolling operations and thus to reduce the time taken for the treatment of each bar. Anshan Steel used this method on its initial rolling machine, and the number of times a steel bar went through the rolling operation was reduced from 17 to 9, and the time taken in treating a bar reduced from 52 to 32 seconds, so that output was raised by nearly 50 percent.

Where the volume of the principal motor of the rolling machine permitted, output can also be increased by changing the accelerator to increase the revolution of the rotor to increase speed, or by increasing the diameter of the rotor for the same purpose. The No. 2 Plant of Shanghai Steel changed a motor of greater volume, and the speed of rolling increased from 12.2 meters per second to 16 meters, and output was raised 33 percent.

Continuous rolling is another effective measure for increas-

ing the speed of rolling. In a continuous rolling operation, manual feeding of steel can be dispensed with, auxiliary working time is economized, and rolling speed is increased.

Existing rolling equipment in China is mostly of the horizontal type, and additional machinery can be placed behind the compartment for finished products, so that continuous rolling can be carried out. In the No. 10 plant of Shanghai Steel, continuous rolling was carried out on the wiring materials machine and compartment for finished products, and the speed of rolling was raised from 5.3 meters per second to 6.76 meters per second, while output was correspondingly raised. After the continuous rolling method was used in the Shanghai Steel Belt Plant, output was increased by 130 percent, and longer steel belts were produced.

In addition, by increasing simple small mechanized equipment in the rolling workshop, and raising the extent of mechanization in operation, we can also reduce auxiliary working time, improve the labor conditions of the workers, and increase output. There are many kinds of simple small mechanized equipment, such as: steel outflow machine, automatic rolling lane, elevator, gas levers, steel removal machine, slag disposal machine, and scissors. They call for small investment but results are extensive. The steel workers of Shanghai, Tientsin and Shenyang have created many kinds and many types of small mechanized equipment, and they deserve to be popularized.

In the popularization of the advanced "multi-bar and rapid rolling method," in addition to the adoption of the series of measures on the rolling equipment, we also need to correspondingly intensify measures in heating, cutting, freezing, correction and inspection fields, so that the entire production process may be balanced.

Raise High the Red Banner of "Multi-Bar and Rapid Rolling", and March Forward

At present, the advanced "multi-bar and rapid rolling" experience is being popularized on a nation-wide scope, and gigantic achievements have been obtained. But there have been obstacles. For example, some people hold that where the power of the principal motor of the rolling equipment is not adequate, the popularization of the experience will be restricted.

It is true that the popularization of the advanced "multi-bar, rapid rolling" experience will increase the load of the principal motor. However, looking at the situation of the load of motors of rolling mills generally, some motors still have potentials which can be developed, and some have replaced old motors with new ones of greater volume in their production increase plans for 1959. All this has created conditions for the popularization of the advanced experience.

Some people hold that the steel rolling equipment and accelerator equipment are not powerful enough and this restricts the popularization of the advanced experience. Naturally, in

the application of greater pressure, the acceleration of rolling speed and the increase of bars fed, we must give consideration to the safety of equipment. Nevertheless, through the evaluation of the pressure power of rolling equipment, and the calculation of the strength of various other equipment, we can ascertain the power of our equipment, discover the weak links, and then proceed to eliminate these weak links positively, so that the steel rolling equipment may develop fully its potentials. Anshan Iron and Steel Company, Chungking Iron and Steel Company, and Shenyang Steel Works all carried out evaluations of pressure power and calculation of the strength of other equipment, and proved that they had great potentials to be developed.

There are still other people who hold that on the multi-trough discs and continuous rolling machinery, only excellent molding steel can be used, and that if small steel ingots are used, there will be too many obstacles and accidents and output cannot be raised.

This is a passive sentiment involving fear of difficulties. The quality of small steel ingots is being raised daily. Even if temporarily they do give rise to difficulties, these can be overcome with the mobilization of the masses to devise ways to do so. At the moment, some rolling mills are overcoming this difficulty by making selections in feeding the furnace with steel ingots, and in the course of rolling, the bad portions of the ingots are also taken out.

VIGOROUSLY DEVELOP TECHNOLOGICAL REVOLUTION,
INTENSIFY WORKING OF NON-FERROUS MINERALS

The following are extracts from an article by the Development and Selection Office, Non-Ferrous Metals Department, Ministry of Metallurgical Industry, in Yeh-chin Pao (Metallurgical Journal) No. 44, Peiping, 6 November 1959, pages 69-71.7

In 1959, the output of mineral copper is estimated to show an increase of more than 30 percent over 1958; the output of aluminum is estimated to show an increase of more than 40 percent, and the output of other non-ferrous metals will also show a marked increase.

Following the development of the national economy, we need more and more non-ferrous metals, and the output of non-ferrous minerals must be continually increased. Particularly during the past few years, we have constructed many new ore dressing plants, while the overwhelming majority of the old ore dressing plants have also been expanded and renovated, so that our capacity for dressing mineral ores has increased greatly.

As an example, after its expansion in 1959, the Tung-kuan-shan Ore Dressing Plant has had its capacity raised by 50 percent. Some tungsten dressing plants have had their capacity increased by two times after expansion. The leaping development of ore dressing plants demands the intensification of the development of mineral deposits, so that mineral raw materials may be supplied in greater

quantities, faster, of better quality, and more economically.

Only thus may the dressing plants be sufficiently fed and better fed, and their capacity be fully exploited.

To make proper preparations for the greater leap forward in 1960, we must adopt the following measures, and strive to intensify the working of various mineral deposits.

Facts since 1958 have proved that in any mine where super-expansions are broken down, the mass movement is vigorously promoted, ways and means are devised to overcome difficulties, that mine will report a great intensification of its operations.

A good example is furnished by the Shou-wang-fen Mine which adopted the experience of the deep-hole crushing method of working the mineral deposits. This is a comparatively new technique of greater complexity. Because of the lack of experience, many difficulties were encountered at first. But the workers were not overawed by the difficulties, when they started the method in 1958 on a trial basis. They lacked deep-hole rock crushing machines. So they broke down the mysterious theory that drills could not be used for deep-hole boring. They took out from the store several drills which they remodelled into tools suited for deep-hole rock breaking operations. They had no crushing tools and such equipment as rods and welders, and they manufactured them themselves. They had no nichrome steel for the making of the tips of welders, and they boldly used carbon steel as the substitute.

When they carried out an explosion, they did not know how

to connect the wires of the detonator, and they resorted to the "three combination" method to study it, and bring up a design which was tested several times before it was officially employed. The first time they carried out a large explosion, there was a mishap, and much of the dynamite failed to explode, leading to great difficulties.

During the period of more than one year since passed, they brought the deep hole rock crushing method to a mature stage, and laid the good foundation for the populatization of this method in China.

On the other hand, Soviet experts had at an early date recommended, in certain mines, the use of the mineral development method of breaking up different layers in the case of thick beds where the surrounding rocks are instable. We should have earnestly taken up at an early date this recommendation of the Soviet experts, but at the time, ideological liberation had not been achieved in certain quarters, and this suggested method was considered too mystical, so that there were great doubts. The biggest anxiety was for accidents. Action was repeatedly delayed and the method was not tried until two years had passed, which affected the earlier development of large quantities of mineral deposits.

The vigorous development of high efficiency and powerful measures is the basic measure for the strengthening of mineral development operations.

Very complex conditions exist in the non-ferrous metal mineral beds, and there are many and varied methods for the

working of the deposits. The proper selection of advanced methods which are also suited to the conditions of the mineral beds is of great significance to getting good results.

Mineral development methods found very effective include the mineral retention method, the method of working medium size and small sections, the pillar development method, and the rock crushing method. These methods are not only powerful, but also have a high rate of labor productivity, and are safe in operation, meeting the demand for quantity, speed, quality and economy. We should vigorously popularize these methods in accordance with conditions of the mineral beds, and develop a great revolution in the method of mineral development.

The Shou-wang-fen Mine in 1958 successfully mastered the highly efficient method of deep hole drilling and rock crushing, and in that year its mineral development intensity doubled that of 1957. It is estimated that in 1960, the intensity will be further raised by nearly 50 percent over 1958, or 200 percent over 1957. In 1959 the intensity showed another increase of nearly 50 percent over 1958, or nearly 200 percent over 1957.

The growth of the intensity of mining operations promoted the development of the production level of mines: in 1958 the output of minerals increased by more than 100 percent over 1957, and for the period January through September 1959, the output increased by nearly 50 percent over the same period of 1958.

Through the movement for technical revolution, the Chung-nan

Tungsten Mine discovered the correct development course in working slanting thin mineral veins with the expansion of the scope of the mineral retention method. In working mineral beds surrounded by instable rocks with the deposits easily shaken up, the mine also experimented on the use of shafts, multiple pillars, and horizontal bars to give firm support to the surrounding rocks, and thus laid the technical foundation for the expansion of the mineral retention method. The intensity of operations and the output of tungsten were greatly and rapidly increased. According to the results of experiments carried out by a certain tungsten mine on the mineral retention method supported by shafts and pillars, the intensity of operations was raised by more than 100 percent, and the efficiency of the miners was raised by more than 150 percent.

The No. 1 Rare Metals Mine broke down conventions and restrictions, and practiced the method of repeated development with simultaneous attention to different sections and the simultaneous use of different processes. This led to the reduction of the number of sections to be worked, and created the experience of high intensity repeated development. It also created conditions in the future for the adoption of high efficiency deep hole development methods in the working of deposits at deep levels, promoting the greater development of production from mines.

On the other hand, the filling up method, the horizontal bar method, and the square frame filling up method are methods without good results. Not only is the intensity of operations low, but

production costs are also high, and safety conditions are not perfect. Mines using these methods must all the more mobilize the masses to adopt revolutionary means to change to high efficiency methods. Should changes be not possible at the time being due to restrictive conditions, existing measures must be effectively improved so as to gradually raise the intensity of operations.

Generally speaking, non-ferrous metal deposits in China may be divided into two major categories: thick beds and thin veins. Of the latter category, most deposits belong to the class of slanting beds. For the thick mineral beds, we must vigorously popularize the deep-hole rock crushing method. For the slanting thin veins, we must expand the scope of the use of the mineral retention method, as the direction to follow in the future. We must also popularize the use of shafts, multiple pillars and horizontal bars in the mineral retention method in working mineral beds surrounded by instable rocks.

In addition, with reference to mineral beds subject to considerable positional changes, such as layers separated at times and reunited at others, and thin veins sometimes slanting and sometimes upright, we have basically not yet discovered rational methods of development. The masses must be mobilized to devise ways and means to improve the situation.

The strengthening of preparations for prospecting and mineral development, and the planning of adequate production

of mineral supplies constitute the material foundation for the continual raising of the intensity of mining operations.

To guarantee normal production and the continual growth at high speed of the production level, we must have adequate quantities of mineral deposits for production needs (mineral deposits under development, mineral deposits ready for development, and mineral deposits for reserve.) For this reason, the strengthening of prospecting work and preparations for development are of great significance.

The raising of mineral development efficiency is an effective guarantee for the raising of intensity of operations.

When we adopt mineral development methods of great intensity, efficiency must be high. On the contrary, with the raising of development efficiency, the intensity of operations must in turn be increased. With the raising of the efficiency in the digging of channels, the work of prospecting and preparation for the development of mineral deposits will be accelerated, and this will guarantee the high speed development of mining operations.

The active renovation of tools and equipment is an effective guarantee for the raising of the intensity of mining operations.

The reduction of loss from poor quality minerals and the raising of the quality of minerals developed are important measures guaranteeing the double leap forward in quantity and quality.

Simultaneous with the raising of the intensity of operations, we must also guarantee the quality of the minerals. We must

mobilize the masses to adopt all effective measures to reduce the impoverishment and loss of minerals during the course of development.

We must definitely ensure safety in operation.

At present, in the non-ferrous metal mines, we must develop the three-high (high output, high quality and high efficiency) one-good (good safety measures) red banner emulation drive centered round the technological revolution and technical renovation, with production increase and economy as the goal. In this drive, we must uphold as our important policy the prevention of accidents and the guaranteeing of safety in production.

CURRENT TASKS IN CAPITAL CONSTRUCTION

The following are extracts from an article, by the Capital Construction Division of the Ministry of Metallurgical Industry, in Yeh-chin Pao (Metallurgical Journal), No. 47, Peiping, 27 November 1959, pages 19-20.]

There are three special characteristics in the current excellent situation of capital construction in the metallurgical industry.

The first is the rapid completion of the large number of engineering projects which have since been thrown into production. During the period from August through the first half of November, 1959, 140 projects were completed and thrown into production. Among them were 30 blast furnaces of more than 55 cubic meters, and their number and total volume equalled those completed from January through July 1959; and 87 converter furnaces, more than the number completed from January through July, and with twice the planned production capacity of those completed from January through July. In addition, there were two large open hearth furnaces, 15 electric furnaces, four sintering machines, one 65-hole coke furnace, as well as medium size and small copper selection plants, small aluminum plants, aluminum electrolysis plants, nickel and tungsten selection plants and lead electrolysis plants.

The second feature is the fact that investments during the months from August through October 1959 showed an increase of more

than 100 percent over the investments in June and July.

The third, and most important, characteristic is the development of the large scale friendly emulation drive for speed and quality. After the conclusion of the capital construction conference held in Wuhan, various provinces and various capital construction units actively implemented the spirit of the conference, and the friendly emulation drive for speed and quality has been developed to a new high with the leadership taking a hand directly, and with the holding of competitive rallies, the planting of the red flag, the election of model fighters, and the movement to study from the advanced, to compare with the advanced, to catch up with the advanced, and to help the backward.

Because the movement was launched in a proper manner, a new situation emerged in which the following was noted among most units: the notable acceleration of construction speed; the marked improvement in work quality; the noticeable reduction in production costs; and the reaping of a big bumper harvest of an overall leap forward.

Take for example the construction of the No. 2 open hearth furnace of the Wuhan steel plant. Only 30 days elapsed from the start of construction to the commencement of production by the completed plant.

The Ma-an-shan Iron and Steel Company used only 6 days, 20 hours and 15 minutes to build a 90-meter high cement concrete chimney.

The Northwest General Metallurgical Company completed the whole year's task in a construction project 68 days ahead of schedule.

The Hunan Metallurgical Bureau fulfilled its plan for the entire year two months and three days ahead of schedule.

Where there are two contracting parties to an agreement, both have promoted closer coordination, and they have greatly developed the Communist character of cooperation manifested in mutual support, mutual help, mutual exchange of experiences, and mutual supply of each other's needs. As an example, a certain plant in the Northeast was carrying out piling operations for the 1,078/cubic meter foundation for its 650 millimeter rolling equipment, and the whole task was completed in 17 hours 57 minutes with the selfless help given it by two other plants, one in Penki and the other in Dairen.

To fulfill in advance and to overfulfill the capital construction tasks of 1959, we must strive every minute and every second to grasp tightly the following tasks:

1. We must take a firm hold of those items which are scheduled for completion within 1959 to be thrown into production, and strive to fulfill in advance and overfulfill these tasks. The Wuhan conference on capital construction decided on 310 items to be completed during the period from August through December 1959, and of these, 170 are still to be completed.

2. We must grasp vigorously the capital construction tasks in the weak links of the iron and steel industry. The two weak

links are : the supply of raw materials for iron smelting; and production in steel rolling. In the former case, the major issue is that ore selection and sintering capacity is not adequate for the needs of iron smelting. In the latter case, the major issue is that the production capacity for certain categories of steel products is not adequate.

Accordingly, those capital construction projects scheduled for production in 1959 must be completed on schedule and thrown into production. As to projects scheduled for completion in 1960, we must strive to complete as many of them as possible. We must also proceed intensively with the building of a system for the supply of raw materials and the construction of steel rolling plants.

With reference to steel rolling equipment planned for construction in 1959, 82 sets of equipment were to be ready for production within the year. At present, 27 sets will still have to be completed within the next month if they are to be ready for production. The steel products to be manufactured by such equipment are all urgently needed by the state, and so we must intensify efforts to get them constructed rapidly to be ready for production. We must also consider it a central task to make proper preparations for the steel rolling projects set for completion in 1960, and strive to have them ready for production ahead of schedule.

During the past few years, there was rapid development in the working of iron deposits. But this still did not satisfy the

needs of the big leap forward in the iron and steel industry.

To make available adequate raw material supplies for iron smelting, we must actively organize a specialized force for the accelerated development of mineral deposits, increase technical equipment and strengthen leadership over such a force. This affects the speed of development of the mining enterprises, and must receive special attention. At the same time, we must also give timely attention to the technical renovation of small and medium size mines.

To satisfy the needs of iron smelting and to increase the output of iron and raise its quality, we must also intensify the building of coke furnaces. For 1959, we planned the building of 1,500 simple coke furnaces of the Red Banner No. 2 type. By early November, 863 of these furnaces had started production. We want the remaining 637 furnaces to be ready for production within the month of November. We also planned the building of 400 simple coke furnaces of the No. 3 type for the year, and to date we have not yet started work on 140 of them. Their construction must begin immediately and they should be completely built and thrown into production in December. A few mechanized coke furnaces must also be completed and thrown into production during November and December.

3. On the foundation of the 1959 big leap forward, we must continue to achieve a further big leap forward in capital construction in the non-ferrous metals industry. The development

of the non-ferrous metals industry affects the development of all departments of the national economy as a whole, and many non-ferrous metals are raw materials urgently needed by the state. Accordingly, whether the engineering projects are planned for completion and production in 1959 or in 1960, we must strive to have them completely built and thrown into production on a schedule or ahead of schedule.

The small aluminum plants should in 1959 a share of the production task which cannot be considered small. In those small aluminum plants already completed and thrown into production, we must see to the complete construction of all the electrolysis troughs so that they may be utilized as soon as possible. Those small aluminum plants not yet completed must be completed at an early date, and all ways and means must be devised to ensure this.

OVERALL BIG LEAP FORWARD IN METALLURGICAL
CONSTRUCTION

[The following are extracts from an article in Yen-chin Pao (Metallurgical Journal), No. 47, Peiping, 27 November 1959, pages 22-23.]

A certain steel plant at one time spent 153 days in building its first 15-ton electric furnace. Recently it constructed its No. 2 and No. 3 open hearth furnaces, both of 15 tons, and it used only 39 days and 31 days respectively to complete the construction of the two furnaces. There were no serious accidents in the course of construction, and construction costs were greatly reduced.

The Northwest Metallurgical Construction General Company overfulfilled its 1959 construction plan 68 days ahead of schedule. After this, it continued to implement vigorously the work policy of "rapid construction, excellent quality, economy and cooperation" and achieved a further overall bumper harvest.

The Penki Iron and Steel Company spent only 45 hours for the entire job, from beginning to end, of piling cement concrete for the foundation of its first major steel rolling equipment. The Dairen Steel Works next took up a similar task, and spent only 22 hours 47 minutes on it. Another plant in the Northeast was the third to do a like job, and it spent only 17 hours 57 minutes in piling cement concrete of a volume of 1,078 cubic meters.

[After the Wuhan conference on capital construction, the metal-

lurgical plants and mines in Kwangtung developed the Communist character of mutual promotion and mutual assistance. Equipment temporarily not in use in a certain plant was taken out to give support to fraternal enterprises.

The Lien-nan Lead and Zinc Mine took out 27 motors which were not needed in 1959 but would be needed in 1960, and lent them to five fraternal plants, thus helping them to partially solve the problem of the lack of small motors which had been a long term difficulty.

The Canton Iron and Steel Works also made available to three fraternal units some motors which it did not need for the moment. One of these motors, of 1,000 kilowatt, not only completed the set of high pressure pump equipment, but also played an active role in enabling the relevant plant to start production on schedule.

MINES SERVING OPEN HEARTH FURNACES MUST
CONTINUE THE BIG LEAP FORWARD IN 1960

[The following are extracts from an article in Yeh-chin Pao (Metallurgical Journal), No. 47, Peiping, 27 November 1959, pages 27 and 21.]

In the middle of November [1959], the Ministry of Metallurgical Industry convened in Peiping a conference of mines serving open hearth furnaces. The meeting called on all mines producing minerals for use in open hearth furnaces to oppose rightist thinking fiercely, exert the utmost effort, and actively prepare for production, so that in 1960 they may produce more and better minerals for the use of open hearth furnaces, and guarantee the big leap forward in steel refining in open hearth furnaces and electric furnaces.

The meeting held that minerals used in open hearth furnaces are important raw materials indispensable for the refining of steel in open hearth furnaces. On the basis of existing consumption conditions in the open furnaces in the steel industry, for the refining of five tons of steel in an open hearth furnace, one ton of open hearth furnace mineral is required. For this reason, the use of all ways and means to increase the output of open hearth furnace minerals is an extremely glorious task. During the past few years, workers in the open hearth furnace minerals development industry, stimulated by the high speed development

of the iron and steel industry, have promoted greatly the increase of production. The output of 1958 showed an increase of 50 percent over 1957; and the output of 1959 is expected to show another increase of 40 percent over 1958. The requirements of open hearth furnace minerals have been basically met. However, in accordance with the demands of the continued big leap forward in the iron and steel industry in 1960, it is necessary that, on the basis of the achievements of 1959, we increase the output of open hearth furnace minerals by from 40 to 50 percent. The task is very gigantic.

The meeting pointed out that though the task in 1960 is very heavy, it can be fulfilled completely. First of all, as the result of the practice over the past two years in the vigorous development of the mass movement, we have accumulated a whole set of experience in the mobilization of the masses and the promotion of the mass movement.

Second, after two years of the big leap forward, we are continually developing and strengthening the bases of minerals for open hearth furnaces. In 1957, there were only two such bases of a large size in the whole country, but today there are more than ten bases of large, medium and small sizes.

Third, after two years of the big leap forward, we have evolved a set of measures and systems suited to the development of production in the production and management of mines producing minerals for open hearth furnaces.

The Ling-hsiang Iron Mine before July 1959 produced an average of about 670 tons of minerals for open hearth furnaces a day. Since August, the leadership of the mine criticized the rightist ideological trends of waiting for favorable conditions and failing to rely on the masses, and developed among the masses an emulation drive with great fanfare. As a result, output rose in a vertical line, and the average daily output in October reached 2,300 tons, an increase of more than two times over July.

After criticizing certain cadres for their rightist feelings of fearing difficulties, war weariness, and relaxation of efforts, the Chin-ling Iron Mine extensively developed the "one dragon" competition, the hand-to-hand competition, and the ladder competition (with the backward first catching up with the intermediary elements and then with the advanced). Production in September and October rose fiercely. In the No. 2 workshop of this mine, one work team increased the number of wagon-loads handled each day from 324 to 449, an increase of 40 percent approximately in work efficiency.

The meeting gave a very high valuation of certain experiences reported by the Li-kuo, Ta-li-tzu, and Kuo-tien mines. These included the "four separation" experience (separate development, separate transport, separate sieving and separate storage) used for blast furnace minerals, open hearth furnace minerals, and mineral dust; and such practices as the manage-

ment of storage yards and the strengthening of analysis measures. The meeting held that these are effective measures to raise the quality of open hearth furnace minerals. It called on all mines in the country producing open hearth furnace minerals to study and use these experiences so as to guarantee the supply of more high quality minerals for open hearth furnaces.

SMALL-SCALE IRON AND STEEL INTEGRATED
ENTERPRISES HAVE DONE MANY THINGS FOR
RURAL AREAS DURING GREAT LEAP FORWARD

The following is a full translation of an article, by the Industrial Office of the Yu-hsien Committee of the Chinese Communist Party, in Yeh-chin Pao (Metallurgical Journal) No. 47, Peiping, 27 November 1959, pages 32-34.

In the wake of the new situation of the great leap forward in industrial and agricultural production, in the wake of the development of the movement for the universal building of people's communes, and in the wake of the wave of enthusiasm for the vigorous development of the iron and steel industry, in December 1958, in the Chiu-pu-chiang People's Commune in Yu-hsien, Hunan Province, the Iron and Steel Integrated Enterprise was born.

From its very birth this enterprise revealed its powerful vitality. Its output grew day after day, and its face had a new look day after day. During the more than eight months which have elapsed, it has gradually developed from a small iron smelting unit operating on native methods to a comprehensive integrated enterprise combining native with modern methods. It is capable of refining iron and steel, and also of rolling steel and producing wiring, and is further in the position to manufacture various kinds of small equipment and tools. It develops its own mineral deposits and produces its own coal, thus becoming a comprehensive unit for continuous production.

The whole plant has six workshops: smelting, steel refining, steel rolling, foundry, machine building and wooden mold making. There are also eight companies in charge of fuel production, transportation and other operations. The equipment of the plant consists of the following: one small blast furnace of 12.5 cubic meters, and another small blast furnace of 4.25 cubic meters; six native furnaces; ten low-temperature iron smelting furnaces; four all-purpose steel rolling machines; one 6-foot lathe; 14 sintering furnaces; one iron casting furnace; four 30-horsepower locomobiles; one 25-horsepower engine, and another 12-horsepower engine; four 1.7 kilowatt motors, two 5-kilowatt motors, and two 4.5 kilowatt motors; one pump; four "shih" type pneumatic machines; six centrifugal pneumatic machines; 10 hand-pulled wooden bellows; one 15-kilowatt motor generator; two automobiles; four junks; and 300 native carts. The total value of these assets is 460,000 yuan.

The products of the plant include: native iron, native steel, pig iron, steel products (including flat steel, round bars, mild bars, nails, and steel wire), machinery processing, lumber processing, and cast iron products, more than 20 categories in all.

During the period from January through August 1959, the output of the plant included: 1,303 tons of iron; 790 tons of native steel; 52 tons of steel products; 70 tons of cast iron items; 0.269 ton of lead wire; 536 native carts; more than

3,000 sickles; more than 1,500 farm tools (including newly made and repaired), as well as 3 pneumatic machines, one crushing machine, and 62 rapid reaping machines. The total value of the output was 2,506,000 yuan.

Not only were the products varied and their value great, but their quality was also very good. According to analysis and inspection made, 95 percent of all products met standard specifications. To take the case of pig iron, 100 percent of the iron had less than 0.03 percent of sulphur content, and more than 2.57 percent of silica content. The entire output is iron of good quality.

Particularly since September 1959, under the call of the Eighth Plenum of the Eighth Central Committee of the Party, the workers of this plant criticized rightist feelings, exerted greater effort, and production registered a greater leap forward. The daily output of pig iron rose from 4.5 tons to 5.5 tons, an increase of 22 percent, and the utilization coefficient reached 1.29. The daily output of native iron rose from 4.3 tons to 4.5 tons, which is 30 percent in excess of the output capacity. The daily output of native steel rose from 4.0 ton to 4.5 tons, an increase of 12.5 percent. The daily output of steel products rose from 0.3 ton to one ton, an increase of 333 percent.

Labor productivity was greatly raised, and production costs were reduced to a marked degree. One ton of iron only used 41 man-days of labor, being 14 percent of the amount needed when

the enterprise was first set up. The production cost of one ton of pig iron dropped from 236 yuan to 196 yuan; that of native iron from 206 to 160 yuan; that of native steel from 245 to 233 yuan; and that of steel products from 1,200 to 620 yuan. The quality of products was raised to a marked degree. The sulphur content in the pig iron dropped from 0.05 percent to 0.035 percent, while the silica content increased to more than 2.89 percent.

After the establishment of the iron and steel small native integrated enterprise, not only were production achievements remarkable, but a large amount of capital was also accumulated, to effectively coordinate with the state's large industry, to greatly support agricultural production, and to push forward the development of the people's commune. At the same time, it also further laid the good foundation for the development of small native integrated enterprises.

First, the enterprise pushed forward the development of industrial activity of the people's commune as a whole. The commune originally had only two agricultural tools works. Today it has a coal mine, lime works, paper works, chemical fertilizer works, farm tools works, tailoring shop, and snipbuilding works, and other enterprises, totaling 26 small size factories, with a total of 1,340 workers.

The establishment and development of these factories were on the one hand due to the needs of production on the part of

the people's commune itself. On the other hand it was also because the small native iron and steel integrated enterprise, after establishment, supplied these enterprises with raw materials, tools, capital and technical forces. During the past half year and more, the iron and steel integrated enterprise supplied these various factories with 150 tons of native steel, five tons of pig iron, 10 tons of steel products, over 1,000 sets of screws, as well as more than 600 pieces of various tools, including welders, axes, hammers, pikes, native wagons, mill stones, hand supports, hoes, and harrows. The enterprise also supported and trained 59 technical workers, and supplied capital to the amount of 43,000 yuan. Thus the iron and steel enterprise guaranteed the normal development and production needs of the various industrial plants.

Second, the iron and steel enterprise effectively supported agricultural production. It produced more than 3,000 sickles, 530 native carts, repaired and manufactured 140 grain threshing machines, installed eight pumps and rice milling machines and 30 rapid grain reaping machines, and over 680 small farm tools, eight automatic water lifting machines, 89 sprayers, and also economized labor to the extent of 132,480 man-days, in addition to greatly reducing physical exertion through all its contributions.

The enterprise also made available to agriculture capital to the amount of 103,721 yuan (of which the workers invested

60,000 yuan, and the remaining 43,721 yuan represented profits of the enterprise.) It purchased for the commune 66,500 chin of insecticides, 240,000 chin chemical fertilizers, and nine pumps.

The iron and steel enterprise further supported agriculture technically and laid the good foundations for the mechanization of agriculture. In 1958 the people's commune had a pump which was responsible for the irrigation of 600 mou of land. The pump broke down, and there was nobody to repair it, so that the 600 mou of land suffered from drought and production was reduced by 50 percent. In 1959 the commune bought nine pumps. The iron and steel enterprise assigned 10 technicians to install the pumps. It also trained 30 technical personnel to operate the pumps. The latter were thus normally utilized, and instead of the 50 percent output reduction experienced in 1958, a bumper harvest was reaped over more than 7,000 mou irrigated land in 1959.

Furthermore, the development of the iron and steel enterprise led the way to the development of other industrial enterprises. The latter aided agriculture with the production of 4.2 million chin of lime, 1.5 million chin of coal, 700,000 chin of native chemical fertilizers, and more than 9,000 items of farm tools (including newly manufactured and repaired), and the needs of agricultural production were thus met.

With the strong support from the iron and steel enterprise, agricultural production was greatly raised, and the average yield per mou of the early rice crop reached 465 chin, an increase of

22.1 percent over the big leap forward year of 1958. The late rice crop is growing even better than the early crop, and a bumper crop is already assured.

The establishment of the steel and iron enterprise also guaranteed the materials needed for the reform of farm tools, and this promoted the appearance of the hightide of the commune's movement for the reform of tools, reduced physical exertion, economized labor, and promoted the development of sideline occupation. In 1959, the commune raised over 16,000 head of pigs, 420,000 chickens and ducks, and 11 million fish. On the average, each household has 1.7 head of pigs, and each person has ten chickens and ducks.

Third, the iron and steel enterprise coordinated with the state's large industrial enterprises, and accumulated capital for socialist construction. From January through August 1959, the enterprise made available to the state 384 tons of pig iron, more than 550 tons of native steel, three tons of steel products, and six tons of cast iron items. It paid to the state taxes to the amount of 18,000 yuan, thus coordinating closely with the efforts of the state, and guaranteed the capital and raw material requirements of the large industrial undertakings.

Fourth, the iron and steel enterprise supported capital construction. It supplied the Chiu-p'u-chiang Reservoir project at Yu Hsien with 30 tons of native steel, five tons of steel products, ten tons of cast iron items for the manufacture of 3,000 hoes. It also supplied the iron parts for the more than

10,000 carts for the reservoir project and thus guaranteed the early completion of this large reservoir which will irrigate 220,000 mou of land.

Fifth, the iron and steel enterprise promoted the development of the people's commune's communications and transport enterprises. After the construction of the iron and steel enterprise, it bought two automobiles, manufactured 300 native carts for its own use, and manufactured for the commune more than 1,200 native carts, and repaired a 16-li native railway line. It also built 84 pathways. It supplied the ship building works with raw materials to repair 32 vessels and manufactured ten new ships and thereby promoted the development of the transport and communications enterprises.

In the past the people's commune had 32 vessels. But because it had no nails and steel products, for a long time the vessels could not be repaired to take to the waters, and only 12 vessels were operated on normally scheduled services. The iron and steel works on its establishment produced nails and guaranteed the restoration of all the vessels to good repair. Thus the people's commune realized, in the transportation field, the operation of carts on the ground, the navigation of the rivers, and the use of roped highways on the higher levels.

Sixth, the iron and steel enterprise armed itself with facilities to lay the foundations for further development. After eight months of production, the iron and steel enterprise added

considerable equipment, trained 32 workers to take care of power generation and machine maintenance, three automobile drivers, 24 steel rolling workers, 11 workers to take care of vehicles, pincers and lathes, 26 workers at the blast furnaces, and 14 workers for the foundry. It thus provided equipment and technical forces for further development.

Seventh, because the iron and steel works is operated by the people's commune, during the busy farming season, the workers can be called upon to give support to agriculture. For example, during periods of emergency harvesting and emergency sowing operations, the iron and steel enterprise would assign 210 workers to proceed to the large work brigade of the commune to work for 20 days to guarantee the advanced fulfillment of tasks, and to advance by one season the sowing of the late rice crop. During the periods of slackness in farming activities, the commune can in turn assign peasants to support the enterprise.

During September 1959, to help the iron and steel enterprise prepare for fuel needed in the winter, the people's commune assigned 1,000 units of manpower for shock efforts in the repair of the highway for the transportation of minerals, and another 100 persons for transport activities. In this way the relationship between the commune and the enterprise was made the closer.

From the above conditions, it can be seen that the small size iron and steel integrated enterprise is playing a gigantic role in the people's commune.

In the course of the past eight months and more, through ceaseless work and effort, the iron and steel integrated enterprise has taken root on its firm foundation. Today, spurred by the resolution of the Eighth Plenum of the Eighth Central Committee of the Party, the workers of this enterprise are putting up greater zeal, and production is daily rising. The whole body of workers has drawn up more ambitious plans and proposed the building in 1962 of two 15-cubic meter blast furnaces to raise the daily output of pig iron to over 30 tons. It also plans the use of electric furnaces and converter furnaces to refine steel, striving for the goal of an annual output of 6,000 tons of steel and 3,000 tons of steel products, to appear on a larger scale in the rural areas after the successful consummation of the people's commune movement.

"ALL RED OVER" IN SMALL BLAST FURNACES IN YUNNAN

The following are extracts from an article in Yeh-chin Pao (Metallurgical Journal) No. 48, Peiping, 4 Dec 59, pages 18-19.

For nearly a year the small blast furnaces in Yunnan Province have gone through the process of overhauling, consolidation and development. As a result, the output and quality of pig iron have steadily risen, and production costs have been drastically cut.

In October, 1959, the average utilization coefficient for Yunnan's small blast furnaces reached 1.109, the ratio of products satisfying specifications was 97.4 percent, and the cost of producing one ton of pig iron was reduced to 177.29 yuan. Yunnan has realized, ahead of schedule, the target for cost reduction in small blast furnaces in the province during the fourth quarter of 1959, as laid down by the national conference on production costs for small blast furnaces.

Since 1959, Yunnan Province made careful studies and carried out a further adjustment of the distribution of blast furnaces. At present small blast furnaces are principally distributed over areas with better operational conditions, such as Kunming, Chu-ching, Hung-ho, Yu-chi and Chu-hsiung. The conditions have thus been provided for the lowering of production costs.

For example, the Kunming No. 2 Iron and Steel Works in the past did not have its own mining base, and had to rely on people's

communes for the supply of minerals. Not only were prices high, but supplies were also liable to be disrupted at times. Since the second half of 1959, the plant has acquired its own mine, and the cost of minerals per ton was reduced from 35 yuan (which included transportation) to 15.6 yuan.

In 1958 an average of 35 man-days was needed to produce one ton of iron, and now only 17 man-days are required. The wages portion of the production cost has thus been reduced by 18 yuan on each ton of pig iron.

The Kunming No. 2 Iron and Steel Works manufactured itself the simple ore washing machine and the three-grade sieve (grading is based on the size of crystals), and this led to economization of manpower by more than 30 workers. The utilization coefficient was raised from 0.868 to 1.02.

To raise the quality of the minerals treated in the furnace, and to raise the utilization coefficient and lower the ratio of coke consumed, all plants in Yunnan Province universally strengthened measures for the processing and management of raw materials, reduced the size of the mineral crystals, and carried out the system of placing in the furnace raw materials according to their grades, as well as the washing and sintering of raw materials also according to their grades. In the past, the Kunming No.2 Iron and Steel Works fed its furnaces with mineral crystals of an average size of from 60 to 80 millimeters, but they have since been reduced to a size of from 10 to 30 millimeters.

With the increase in production and the strengthening of control over minerals, coke, and limestone, the cost of the raw material portion of production in the plant was reduced by 69 yuan in the production of one ton of pig iron compared with the first quarter of 1959.

The Kunming No. 1 Iron and Steel Works carried out the sintering of minerals for the separation of sulphur. This not only raised the quality of the pig iron produced, but also because the average quality of the minerals entering the furnace was raised from 30-40 percent to more than 60 percent, the mineral needed for the production of one ton of pig iron is only from 1.7 to 1.8 tons.

Other plants, like the I-men Iron Works, Fu-yuan Iron Works, Lu-feng Iron and Steel Works, the Kunming No. 1 Iron and Steel Works and No. 2 Iron and Steel Works, are also carrying out the process of the sintering of powdered minerals, fully and effectively making use of powdered minerals, mineral dust, coke nuggets and coke dust.

Today the various plants are struggling further to lower costs of pig iron production in the small blast furnaces down to the level of those in the large blast furnaces.

GREAT FUTURE AHEAD OF CONVERTER STEEL FURNACES

The following are extracts from an article by Yu Ching-sheng, chief of the Converter Furnace Office, Iron and Steel Division /Ministry of Metallurgical Industry/, in Yeh-chin Pao (Metallurgical Journal), No. 48, Peiping, 4 December 1959, pages 26-29.

Rightist opportunists have fiercely attacked and opposed the two important links in the group of small modern plants in the iron and steel industry - the small blast furnace and the medium size and small converter furnaces.

Some people doubt if the small converter furnace can produce good steel. The experience of Tsingtao shows that the half-ton side blown alkaline converter furnace can carry out normal production, and the steel refined is of good quality. This is a very valuable experience, and creates good conditions for the greater development of converter furnaces and groups of small modern plants.

From the experience of Tsingtao, the keys to the successful operation of the half-ton converter furnace are as follows:

(1) The hot-air alkaline iron furnace (including the rejuvenation type of iron furnace) provides the converter furnace with liquid iron of high temperature and low sulphur content, guaranteeing the smooth operation of the converter furnace.

(2) The converter furnace is operated at high temperature.

The refining time and the subsequent interval are short. In the Tsingtao Bicycle Plant, each heat takes less than 20 minutes and so not much heat is dispersed. Moreover, the iron alloy and the lime are first heated before they are put into the furnace, and the quantity of lime used is appropriately decided.

(3) Work rules must be strictly observed. The angle in feeding raw materials, the angle at which the furnace is moved, and the depth of the blowing operation must all be carried out in accordance with the work pointers adopted by the converter furnace conference at Shanghai, and supplementary blowing must absolutely be avoided.

The temperature of a small converter furnace is hard to control, and the temperature is easily lowered. Since the small converter furnaces in Tsingtao can carry out production normally, there should be less doubt over the working of the medium size and large furnaces.

At present, with reference to operations in certain plants, the following three important problems exist.

(1) Too much lime is put into the side blown alkline furnaces. Many plants use an amount of lime in excess of 100 kilograms to a ton of liquid iron, which is too much. Excessive lime put into the furnace leads to difficulty in the dissolution of slags and the lowering of the temperature of the furnace. This calls for the need for supplementary blowing (carbon < 0.06 percent with blowing continued), to dissolve the slags and raise the temperature. This

is the main reason for supplementary blowing.

(2) The time taken for each heat is too long. In some plants the time for each heat (including the time for blowing and smelting and the interval that follows) is more than one hour. We must strengthen management and organization of production and the regulation of operations, and reduce each interval to less than 10 minutes.

(3) A plant using pig iron with higher sulphur content must use the hot air alkaline furnace.

At present the converter furnace consumes comparatively larger quantities of iron and steel, the average consumption by the key enterprises being from 1,400 to 1,500 kilograms. From an analysis of the consumption of iron and steel materials, we find that apart from scrap steel, the consumption of iron and steel materials in a side blown alkaline converter furnace includes the following: 6 percent loss from the oxidization of carbon, manganese, silica, sulphur and phosphorus; 2 percent loss from oxidization of iron in the ferric oxidized slags; 2.5 percent loss in the iron furnace; 3 percent loss in the spurting process. The total loss is 13.5 percent (of which 11 percent are from the converter furnace.) The first two items of losses are suffered in an open hearth furnace also. The loss in the iron furnace should not be traced to the converter furnace, for the latter may also take in the liquid iron of a blast furnace. Accordingly the converter furnace actually bears an additional loss, from

spurting and amounting to 3 percent, compared with the open hearth furnace. (Though in some plants the loss in spurting is higher than 3 percent, but it can be maintained at this level.)

A comparison of the costs of production with the converter furnace and the open hearth furnace shows that they are about the same if blast furnace liquid iron is used in both cases. This is because the additional loss from the consumption of iron and steel materials in the converter furnace is compensated by the economy of fuel partly. At the same time, the depreciation of the converter furnace, and worksop management expenses and wages are also lower.

At present some converter furnaces show a higher cost of production. This is principally due to the use of inferior raw materials, lack of experience, and immature operational methods, leading to low work efficiency, low rate of products meeting with specifications, and high consumption of iron and steel materials. This is but a temporary phenomenon, and can assuredly be corrected.

During the past two years, the ratio of converter furnaces in China climbed steadily, and today they have reached 40 percent of all furnaces. It is therefore a very important task at this time to further expand the categories of steel from converter furnaces and the scope of its utilization.

In recent years, the categories of steel products and their uses ave gradually expanded following the development of the trial manufacture of new products and the improvement of their quality. Up to the present, 28 kinds of steel have been produced. They

include: soldering steel with high manganese content and low carbon content of high quality; low alloy high tension steel; silicon steel sheets for electric machinery and transformers; spring steel; cutting steel; industrial steel; horse shoe steel and 九0 and 九3 - 5 ordinary carbon steel.

With the raising of operational levels, particularly the proper control of carbon at the termination point and the oxidized iron in the slags, the Tangshan Steel Works in 1954 successfully experimented on the use of the alkaline converter furnace for the refining of steel with the boiling point process, and the quality of the product was very good. Industrial production was taken up. In 1956 to 1958, successful experiments were carried out in the production of seamless tubes, soldered steel tubes, medium plates, large steel joists, and heavy steel rails, and initial results were satisfactory. In addition, the converter furnace and the electric furnace were jointly used for the production of 40 Chromium, ball bearing steel, and certain types of low alloy steel, and the categories are being daily increased.

From available data, there will be a great development of the types of side blown alkaline converter furnaces (there will also be an increase of the categories of steel from side blown converter furnaces.) The scope of their use will have a very extensive development in the future. When the side blown converter furnace is used solely for steel refining, it generally

can turn out all the categories of products which the open hearth furnace can turn out. But the converter furnace is more suited than the open hearth furnace for the production of low carbon steels (industrial pure steel, and soldering bars) as well as heavy steel rails.

As to the quality of steel from the side blown alkaline converter furnace, in the standards published by the Ministry of Metallurgical Industry, the same demands for the functional quality of the phosphorus, sulphur of the ordinary carbon steel and A class steel are made as those demanded of similar products from open hearth steel, while the carbon content has to be lower than that of similar steel from the open hearth steel.

In practice it has been discovered that under the rigid provisions of the Ministry's standards, steel from the side blown alkaline converter furnace possesses higher submissive point, stretchibility, and pliability for contacts. The soldering capacity of the steel is very good. Under the same conditions of like expansion tensility, its submissive point and stretchibility are better than steel from open hearth furnaces. It may thus be considered that on the foundation of the same stretchibility, with the raising of the carbon content at the terminal point, and the increase of strength for expansion and point of submission, the use of such steel will economize steel products.

Take the case of $\text{K} 3$ (CT3) steel, the submissive point stipulated is not less than 24 kilogram to one square millimeter,

and if this is raised to not less than 26 kilograms per square millimeter, steel products can be economized by 8.3 percent.

If the strength for resistance is raised from the original 38-47 kilograms per square millimeter to 40-49 kilograms per square millimeter, likewise steel products can be economized.

With reference to pliability in contact and capacity for deep thrusts, production experiences have proved that under both normal temperature and low temperature, steel from converter furnaces has a higher pliability than the standards set. The thin plates trial produced in Shanghai for deep thrusts also initially proved that their functionability completely conformed with the highest demands made of thin plates.

In addition, the soldering capacity is also very good. Its sensitiveness to heat is not great, and there is a trend for it to be substituted for open hearth furnace steel as the major soldering steel. The silicon steel produced has good electromagnetic properties, and can be used not only for electric appliances, but also for transformers.

Generally speaking, converter furnace steel can definitely be said to possess good functionability.

Furthermore, with the successful experiment in China of the joint use of the converter furnace and the electric furnace in refining steel, the quality of converter steel can be raised to the level of that of electric furnace steel. From available data the joint use of the converter furnace and the electric furnace

may be carried out for the production of the major portion of alloy steels. This will lead to the manifold increase in the output of electric furnace steel and alloy steel in China, and pave a wider road for the expansion of the types of steel to be produced from converter furnaces.

In 1960, in the use of the side blown alkaline converter furnace by itself, emphasis may be laid on production or the trial manufacture of boiling point steel, large and medium size steel of low carbon content (steel joist, trough steel, round steel), low carbon belt steel, high quality carbon steel, heavy steel rails, medium steel rails, low alloy high tension steel, No. 6 screw steel ribs, soldering steel bars, electric steel, seamless tube steel, cutting steel, spring steel and bridge steel.

As to the joint use of the converter furnace and the electric furnace, efforts may be exerted for the production and trial manufacture of low alloy structural steel, high grade silicon steel sheets, ball bearing steel, high grade carbon structural steel, carbon industrial steel, and alloy spring steel.

Important Technical Development Problems for the
Converter Furnace during the Next One or Two Years

(1) The development of blast furnaces for iron furnaces. The chief characteristics of this measure are: (i) the utilization of the waste gas at top of furnace to preheat the pneumatic equipment; (ii) the water cooling windpipe juts into the furnace (the same as the rejuvenator type of iron furnace); (iii) water cooled and projecting grateless fusion zone (equal to the body of the blast

furnace); (iv) suction type of iron outlet or double bridge for passage of slags and iron to be let out of the furnace.

An iron furnace of such a structure can produce alkaline slags and remove sulphur; the grate will have a long span of life and generally operate for several months; the temperature of liquid iron can be raised to over 1,550 degrees. At the moment, experiments on this type of furnace are being carried out in Shanghai, Soochow and Tientsin.

(2) The converter furnace can directly use liquid iron from a blast furnace to refine steel. At the moment most converter furnaces use liquid iron from iron furnaces for refining steel. Where conditions are available, we may directly use liquid iron from blast furnaces to reduce costs. At present, Ma-an-shan Iron and Steel Company, Penki Iron and Steel Company, and Tsinan Iron and Steel Company have adopted the method of the direct use of liquid iron from blast furnaces for refining steel and they have accumulated definite experiences. When liquid iron from blast furnaces is directly admitted to the converter furnace, the temperature maintenance machine may be used, or else the heat adding furnace may be used (preferably one that may raise the temperature). In the use of liquid iron from a blast furnace, a small converter furnace must pay attention to the question of temperature during the blowing process.

(3) Manufacture of furnace slag phosphorous fertilizer. A side blown alkaline converter furnace refining steel with pig iron of

high phosphorous content can also produce phosphorous fertilizer. The Shanghai No. 6 Plant carried out experiments on pig iron with high phosphorous content. From pig iron with phosphorous content of from 0.7 to 0.8, they obtained furnace slag phosphorous fertilizer with solubility of more than 90 percent, with from 10 to 12 percent of effective P_2O_5 , and agricultural experiments revealed the fertilizing effects to be very good.

China needs plenty of chemical fertilizers, and phosphorous fertilizer will play a great role in increasing the output of grain (one chin of phosphorous fertilizer with 18 percent P_2O_5 can increase grain output by 3 chin). Accordingly, in order to support agriculture, units in China with pig iron of high phosphorous content, such as Hupeh, Kwangsi, Sinkiang, Szechwan, Shansi, Shantung, and Chekiang, are all undertaking the trial production of the fertilizer.

A phosphorous fertilizer workshop with an annual output capacity of 50,000 tons can be constructed with a few hundred thousand yuan. Equipment is simple. What are needed are crushing machines, globular mills, and belt transmission machines. In refining one ton of steel, more than 0.15 ton of steel slag can be obtained, and the cost of processing the slag is only 20 yuan.

In addition, in certain areas, we may also consider, when using minerals with high phosphorous content, the adding of apatite with high calcium and magnesium contents (the use of chemical methods for the production of phosphorous fertilizer with apatite is very

costly). This will increase the phosphorous content in the pig iron, so that the furnace slag will have a higher content of P_2O_5 . We may thus fully utilize China's apatite resources, and correspondingly reduce the processing cost and transportation expenses of phosphorous fertilizer.

(4) New refractory materials. Results of initial experiments show that aluminum-magnesium bricks and high content calcium-magnesium bricks can raise by about 50 percent the life span of side blown alkaline converter furnaces.

(5) Use of Converter furnace combined with process of continuous casting of bars. Continuous bar casting will have a definite future of development in the converter furnace workshop. Because the production cycle of the converter furnace is short, the output of each heat is small, it is specially suited to combination with the process of continuous casting of bars, to fully develop the capacity of continuous casting. The quality of steel can be guaranteed since the temperature movement is slight.

(6) Instruments for control of converter furnace. We must strive to use, in the near future, instruments to control the depth, temperature and terminal of the refining operation, and thus further raise the quality of steel. In 1957, Shanghai and Tangshan steel plants experimented on the use of optical and electric indicators to direct the terminal of the refining area, and achieved good results.

(7) Utilization of spent heat of furnace gas. During the

refining process in a converter furnace, the furnace gas produces plenty of heat. The gas from one ton of liquid iron comes to over 600 kilograms, and the temperature is more than 1,000 degrees. For the utilization of this large amount of heat, foreign countries have succeeded in installing water pipes for pre-heated boilers on the top of the furnace. This heat is used for the generation of electricity which is used to supply the converter for the production of oxygen, and there is more power left to spare.

(8) Steel refining with oxygen. Hydro-electricity and the development of new type oxygen machinery have created conditions for the use of oxygen by the metallurgical industry. The use of oxygen on the top of the converter furnace will raise the quality of steel. Because minerals can be added, the consumption of iron and steel materials can be reduced. In China today we have mainly the side blown alkaline converter furnace. In units with the requisite conditions, oxygen may also be used on the top of the furnace. One workshop of Tangshan Steel Works is already using super-oxygen for refining. Shin-ching-shan Iron and Steel Company will shortly construct a converter furnace with blowing operations from the top.

(9) Utilization of furnace slag. We have dealt with the manufacture of phosphorous fertilizer with slag of high phosphorous content in side blown alkaline converter furnaces. Steel slags should be sent to blast furnaces for use as raw material,

making use of the lime and iron contents therein. When all iron furnaces are changed into blast furnaces, consideration may be given to the use of furnace slag for the production of liquid slag.

From the above we can see that production by the converter furnace has not only written a most brilliant page in the history of the metallurgical industry of China, but that its future is also very bright.

~~HUPEH PROVINCE ENERGETICALLY DEVELOPS
NON-FERROUS METALS INDUSTRY~~

(The following is an extract from an article in Yeh-chin Pao (Metallurgical Journal), No. 49, Peiping, 12 December 1959, page 33.)

Peiping, Yeh-chin Pao, No 49, 12 Dec 59, p 33

The Hupeh Provincial Department of Metallurgy recently convened the first provincial conference on non-ferrous metals. The meeting summed up the achievements in production of the non-ferrous metals industry during the past year, commended the advanced units, exchanged experiences, studied measures for the advanced fulfillment and overfulfillment of the 1959 production targets and discussed plans for the vigorous development in 1960 of the non-ferrous metals industry.

On the foundation of the 1958 big leap forward, in 1959 the non-ferrous metals industry in Hupeh continued to leap forward, and achieved great results. Before 1958, apart from the enterprises directly operated by the Central Government, there was not a single non-ferrous enterprise operated by the province. During the big leap forward in 1958, the non-ferrous metals industry saw flying development, and many small native mines and plants were established in the province. The output of copper in 1958 increased more than 100 times over 1957.

Since 1959, there has been a gradual transition from groups of small native plants to groups of small modern plants. At the

moment, plants which have been completely built and those currently under construction include three small copper selection plants and one aluminum electrolytic plant.

During the first three quarters of 1959, the output of copper showed an increase of 16 percent compared with 1958. More than 80 percent of the copper output are produced with native methods. The output of lead-zinc showed an increase of more than two times; and that of mercury an increase of more than five times. There are also great increases over 1958 output for other rare metals.

SZECHWAN COPPER, LEAD AND ZINC OUTPUT INCREASES

The following is a full translation of an article in Yeh-chin Pao (Metallurgical Journal) No. 49, Peiping, 12 December 1959, page 34.

On the foundation of the 1958 big leap forward, the broad masses of workers on the non-ferrous metals front in Szechwan Province in 1959 continued to persist in letting politics assume command, earnestly implemented the policy of simultaneous attention to native and modern methods, and continually opposed rightist trends and exerted their utmost efforts. Up to 20 November 1959, in the whole province, the state's plans for the whole year have been overfulfilled ahead of schedule in three products: electrolytic copper, coarse lead and coarse zinc.

Szechwan Province is very rich in non-ferrous resources. Copper deposits are particularly found all over the province. During the big leap forward in 1958, all localities in the province vigorously promoted the mass movement, and used native methods to produce large quantities of coarse copper.

Since the beginning of 1959, the broad masses of workers on the copper production front continued to raise high the red banner of the general line, and with their attention centered on the problem of raising the quality of copper, they vigorously promoted technical renovation and the technological revolution, exerting all out efforts to break through the technical

barrier in copper refining.

Workers in the copper industry in the Luchow and I-ping special administrative districts successfully experimented on the moisture method of smelting copper and solved the problem of the treatment of oxidized deposits with high silica content and low quality.

Workers in the industry in the Tung-shan and Hsi-chang special administrative districts further vigorously carried out the reform of furnace types, making it possible for native blast furnaces both to achieve high output and a long span of life. Both the Lung-ch'ih Copper Mine in Tung-shan and the La-la Copper Mine in Hui-li have universally used the radiative furnace for the production of coarse copper. The workers of Ta-tung Copper Mine in Hsi-chang boldly improved operational methods, and placed sintered minerals into the furnace to produce coarse copper with a copper content of about 95 percent.

As the result of the diligent labor of the broad masses of workers, today all localities have mastered the technique for the smelting of coarse copper. Some areas have directly smelted minerals into coarse copper.

To achieve the victory of a continued leap forward in 1959, native production methods have been used on a large scale in the production of such non-ferrous metals as lead and zinc, with the thorough implementation of the policy of combining native methods with modern methods, starting from small operations to large

operations, from points to surface areas.

Since August 1959, after going through anti-rightist studies, the broad masses of workers on the non-ferrous metals front further mustered great zeal and production rose steadily. For the month of October, the output of coarse lead was 162 percent of that in July, while the output of coarse zinc also showed an increase of nearly 100 percent over that of July.

SHENYANG ACHIEVES DOUBLE LEAP FORWARD IN
OUTPUT AND QUALITY OF NON FERROUS METALS

✓The following is an extract from an article in Yeh-chin Pao (Metallurgical Journal), No. 49, Peiping, 12 Dec 1959 p.34.7

By the middle of November 1959, the Shenyang Metallurgical Plant had fulfilled the state plan for the whole year in the total value of industrial production.

During the first half of November, the daily output of copper, lead and zinc reached levels from 10 to 13 percent higher than those prevailing before the holding of the competitive exhibitions in early October. By November 10, the plant overfulfilled the 1959 state plan for copper output by three percent, and that for lead production by 1.2 percent.

The quality of electrolytic copper and electrolytic zinc reached the standards of special grade copper and first grade zinc respectively. Ninety percent of the electrolytic lead produced also reached the standard of special grade lead.

The plant had achieved a double leap forward in production volume and quality of output.

DIFFICULTIES OVERCOME IN CONSTRUCTION
OF TANGSHAN ALUMINUM PLANT

✓The following are extracts from an article in Yeh-chin Pao (Metallurgical Journal) No. 49, Peiping, 12 December 1959, pages 35-36.✓

Tangshan Aluminum Plant was victoriously constructed and thrown into production in August 1959. It was built by the workers of the whole plant under the illumination of the Party's general line with the development of the spirit of adding skill to diligence, and using self efforts for rejuvenation.

Though there are many favorable factors for the construction of a small aluminum mill in Tangshan Municipality, there are also many difficulties. There was not a single technical personnel; both material supplies and equipment were inadequate; designing charts were incomplete; and transportation forces were very weak.

Under the leadership of the Party, the workers of the whole plant were not overawed by these difficulties, but instead they roused themselves to exert the utmost efforts, assumed the roles of heroes, devised all ways and means to overcome difficulty upon difficulty, and finally placed the plant ready for production in the middle of August.

During the more than three months since elapsed, the quality of the products steadily rose, more and more troughs were operated, and consumption of raw materials and power registered a marked

decline. At the moment, the plant is courageously marching forward along the direction of "high output, good quality, low consumption and long life," as pointed out by the national conference of small aluminum mills.

Our plant overcame the difficulty of the lack of equipment. Originally, a portion of the equipment for the rectifier room was due for delivery at the end of December. But we resorted to self efforts at rejuvenation and solved all the problems.

(1) Substitute. We had no cathode shunt, and used native methods as substitute. In accordance with a 75 milli-volt direct current chart which we had bought from a street stall, on the 250 x 29 millimeter aluminum plate at the switch outlet we measured the direct current passing through up to 5,000 amperes and obtained a resistance of 75 milli-volt, and this method was used as a substitute for the cathode shunt.

(2) Self manufacture. We did not have the current distribution disc for alternate current and direct current in the rectifier room. The workers bought from the power company a few galvanometers and voltmeters for alternate current and direct alternate, and made our own current distribution board. We also used native methods to manufacture cathodes and anodes, and switchboard accessories.

(3) Loan. For such supplies as the protective equipment for the high voltage checks for the rectifier transformer, the workers were mobilized to return to their former factories to get help in the form of loans.

(4) The masses were mobilized to think up temporary measures by pooling together their wits. We did not have an anode equalizer, and found difficulty in short circuit reduction in the rectifier. The workers adopted the method of reduction in short term stages, dividing the 12 cylinders into two lots for reduction separately, and then putting them together for a further reduction process. The difficulty was solved.

Again we had no modulation transformer and found difficulty in reduction in the rectifier and the starting of sintering in the electrolytic trough. After discussion, the following two measures were used to solve the problem: on the 35 kilo-volt circuit, 6 kilo-volt power was transmitted into a transformer that changed 35-kilo-volt into 10 kilo-volt. Secondly the electricity was further transmitted into a transformer that changed the 10 kilo-volt into 825 volt. Thus we obtained more than 120 volt of low voltage for reduction.

To solve the difficulty in starting the electrolytic trough in sintering, we placed the power transformer, high voltage checker, and the end of the connecting cord above the highest level of 36750 volt, and the rectifier transformer, high pressure checker and the end of the connecting cord above the highest level of 10,500 volt. This led to the lowering of the anode voltage by from 15 to 20 percent. At the same time we used the regulating angle of the phase modulator to control the grid, bringing the direct current

to about 200 volt.

During the early stage of the commencement of production in the plant, we only operated 20 troughs, being only 20 percent of the capacity of the entire equipment. But we actively strove for the assistance of the leadership of the municipal committee of the Party. Immediately after the conference of small aluminum mills in Chengchow, we reported the spirit of the conference to the municipal committee. We obtained its special attention and support, and the cooperation of the power departments so that power supply was increased. At present we are operating 68 troughs, and very soon we shall be working our entire equipment. During the period from November 1 to November 20, the daily output already showed an increase of 16 percent compared with September.

PREPARE WELL FOR THE "RED ALL OVER" AT THE VERY
START OF 1960 IN NON-FERROUS METALS INDUSTRY

The following are extracts from an article, by the Non-Ferrous Metals Division, Ministry of Metallurgical Industry, in Yeh-chin Pao (Metallurgical Journal), No. 51, Peiping, 28 December 1959, page 32.

As in other industrial fields, the daily output in non-ferrous metals production is rising daily and new records have been continually created.

Take for example the production of copper. The average daily output in September 1959 showed an increase of 9 percent over that in August. That in October and November again showed an increase of from 10 to 11 percent over that in September. By October, the production for the whole year had been over-fulfilled two months ahead of schedule, and the output by that time already exceeded that for the whole of 1958, the year of the big leap forward.

As to other non-ferrous metals and products thereof, both in the mines and in the factories production levels have been climbing steadily. By the end of November 1959, more than 40 percent of enterprises had fulfilled state plans more than one month ahead of schedule.

In 1960, the production of non-ferrous metals will have to proceed forward with even greater speed. The total quantity of

non-ferrous metals developed in the mines will have to more than double that of 1959. The key to the fulfillment of the 1960 mining plans lies in the raising of the output per unit area of the mines (referred to simply as intensity of mining development, meaning the amount of mineral deposits developed over one square meter in one month.)

At the moment some mines produce as much as 70 tons of minerals per square meter per month, while others produce only 10 tons. This fully shows that so long as we raise the output per unit area of the mines, each mine may serve the purpose of two, or even more, mines. This will lead to an overall great leap forward in the digging, elevation to the surface, and transportation operations. In 1960, the mineral selection plants are expected to handle minerals twice the quantity they treated in 1958.

AUXILIARY MATERIALS MINES MUST ALSO
CONTINUE GREAT LEAP FORWARD

The following is an extract from an article by the Geological Minerals Division, Ministry of Metallurgical Industry, in Yeh-chin Pao (Metallurgical Journal), No. 51, Peiping, 28 December 1959, page 34.

Since the great leap forward of 1958, under the illumination of the Party's general line for socialist construction, and guided by the policy of "making steel the principal, and seeking an overall leap forward," workers in the auxiliary materials mines of the metallurgical industry exerted great efforts to guarantee that metallurgical furnaces were "well fed and well clothed", and they scored very great achievements.

Let us cite the following examples. Open hearth furnace minerals: 1958 output showed an increase of 44.3 percent over 1957; and 1959 output is expected to show an increase of 20.7 percent over 1958. Manganese: 1959 output is expected to show an increase of 263 percent over 1957. The great leap forward in iron and steel production has been made possible with the great leap forward in the production of auxiliary minerals.

In 1960 there will be a continued leap forward in the iron and steel industry. To meet the needs of this great leap forward, in addition to the necessity for a continued leap forward in iron production, there must also be a continued great leap forward in the

production of various auxiliary minerals. This imposes an important and glorious task on the workers in mines developing auxiliary raw materials.

NON-FERROUS SMALL MODERN PLANTS ARE FLOURISHING

The following is a full translation of an article in Yeh-chin Pao (Metallurgical Journal), No. 49, Peiping, 12 December 1959, page 32.

The "groups of small modern plants" in the non-ferrous metals industry are being developed and strengthened rapidly. At the moment, there are not only a large number of small ore selection plants and smelting plants in the copper and aluminum fields already thrown into production, but in the fields of lead, zinc, tungsten, tin and gold production, there have also appeared a number of small size factories and mines combining the use of native and modern methods. The output and quality of these small modern enterprises are rising steadily, and their production costs are dropping to a marked degree. This shows that the "groups of small modern plants" in the non-ferrous metals industry will soon develop into an indispensable force in China's non-ferrous metals industry as a whole.

Small copper selection plants. At the moment, in the whole country, construction has started on 116 small copper selection plants. The sum total of their production capacity is greater than the copper selection capacity newly constructed in the whole country during the period of the First Five Year

Plan. Viewed from conditions in the 34 small copper plants already thrown into production, the situation is very good. Take the examples of the plants at Shou-wang-fen, Tung-shan and Ya-shan. They handle 50 tons of copper a day. The quality of the refined mineral averages from 10 to 15 percent. The rate of the recall of minerals has reached 90 to 93 percent. The quantity treated daily has risen from 20 to 30 tons to from 45 to 50 tons. The Hua-yai small copper mine in Shantung is handling 52 tons daily, a quantity in excess of its designed capacity. The turnover rate of the equipment of the Ya-shan Copper Mine has been raised to more than 90 percent, and ore selection costs have been reduced from 57 yuan to 20 yuan per ton.

Small Aluminum Plants. Though the construction of small aluminum plants has been started less than one year ago, the total size of these plants has exceeded 30 percent of the sum total of the sum total of aluminum development capacity planned for new construction in 1959 in the whole country. At the moment, in the whole country there are 17 small aluminum plants already engaged in production, and another 16 are under construction.

Ever since the Ministry of Metallurgical Industry convened in Chengchow the national conference of small aluminum plants, the various targets of these plants have risen greatly. In the past, small aluminum plants generally used current density of from 4,500 to 5,000 amperes. Today there are seven small aluminum plants using current density of 5,000 amperes. In the past very few

electrolytic troughs were operated, but today of such troughs constructed, 83 percent are in operation. There has been a marked rise in the quality of products meeting specifications. Furthermore, there has been a marked decline in power consumption, salt fluoride consumption and production costs.

Small Lead and Zinc Plants In Kiangsi, Kwangtung, Kweichow, and Liaoning, a number of small ore selection plants and smelting plants combining native and modern methods have been thrown into production. In Kweichow, with the accelerated reform of small lead and zinc plants using native production methods, the output of lead from January through November, 1959, showed an increase of 200 percent over the total output of 1958.

In the fields of gold, tungsten, tin and mercury production, some small ore selection plants and smelting plants combining native and modern modern methods are under construction, and others are being planned.

METHODS OF CALCULATING THE MAJOR TECHNICAL AND
ECONOMIC TARGETS OF OPEN-HEARTH FURNACE

[The following is a full translation of an article in
Yeh-chin Pao (Metallurgical Journal) No. 31, Peiping, 31 July
1959, pages 38-39.]

1. Open-Hearth Furnace Calendar Utilization Coefficient

During the calendar period of work, the average output of
steel (in tons) satisfying the required specifications, for one
day/night, over an area of one square meter of the bottom (bed)
of the open-hearth furnace. The calculating formula is:

$$\begin{aligned} & \text{Open-hearth furnace calendar utilization} \\ & \text{coefficient (ton/square meter:day-night)} \\ & = \frac{\text{output of steel satisfying specifications (tons)}}{\text{area (sq.m.) of bottom x no. of calendar working day/night's}} \end{aligned}$$

2. Open-hearth Furnace Calendar Working Day/Night's

This refers to the calendar period covered by a report less
the time used for a general repair of a restoration nature; expressed
in a formula, it is:

$$\begin{aligned} & \text{Open-hearth furnace calendar working day/night's} \\ & = \text{no. of calendar day/night's of the whole period of report} \\ & \quad - \text{no. of day/night's during the period devoted to a general} \\ & \quad \text{repair for the restoration of the furnace.} \end{aligned}$$

3. Repair of Open-hearth Furnace

(i) General Repair: The replacement of all the bricks of the upper levels of the open-hearth furnace, including also the total or partial replacement of the bricks at the bottom of the furnace and the sintering section at the bottom; the cleansing of the steel slags in the slag depository; the complete or partial repair of the walls, roof and channels of the slag depository; the replacement of the upper and lower iron and steel structures of the open-hearth furnace and the strengthening of the individual sections of the building; and the repair of auxiliary equipment and control and surveying instruments.

(ii) Medium Repair: The replacement of all the bricks of the upper levels of the open-hearth furnace, but not the bricks at the bottom of the furnace and the sintering layer at the bottom; the replacement of the water supply equipment and the arch beams on the roof of the furnace, and the partial replacement of the steel structure in the front part of the furnace; the cleansing of the slag in the slag depository and the partial repair of the walls of the depository and channels; the replacement of the bricks in the heat conservation room, and the partial repair of walls and roof of the heat conservation room; and the repair of machinery equipment connected with the operations of the furnace.

(iii) Small Repair: The complete or partial replacement of the roof of the open-hearth furnace; the complete or partial replacement of the front wall of the smelting room above the

door-sill, the partial replacement of the roof of the furnace and the bricks of the stairway; the replacement or repair of the grates in the water supply system, the removal of the accumulated ash in the heat conservation room and the channels; and the inspection and repair of the auxiliary machinery equipment.

(iv) Heating Repair: This includes the digging and refilling of cracks on the stairway and on the roof of the furnace, the replacement of the front and back walls and the water supply system; the soldering of the small arch beams and the cleansing of the gas pipes and the accumulated ash in the heat conservation room and slag depository. To differentiate it from a small cold repair, a heating repair must include the digging and refilling of portions of the cracked walls and the carrying out of repairs while the furnace is heated.

(v) The computation of the repair time: From the suspension of the gas supply to the completion of repairs and the heating of the furnace, including the whole time since elapsed.

4. Calendar Operational Rate

This refers to the percentage of the actual steel refining time during a report period in relation to the calendar working time of the period, viz:

Calendar Operational rate (percent)

$$= \frac{\text{actual steel refining time in period}}{\text{calendar working time in period}} \times 100$$

5. Actual Steel Refining Time

This refers to the entire calendar time of the period of a report less the time spent in cold repairs, hot repairs, and the working of the furnace itself, that is to say, the time used exclusively for the refining of steel.

6. Time spent in working of furnace

This includes: (i) time spent for the heating and repairing of the bottom of the furnace according to plan or not according to plan; (ii) the excess portion of the time spent in heating the bottom of the furnace after a heat of steel is produced, when such time spent in heating exceeds the fixed time assigned for the task. The assigned time (quota) is not included because in the decision of the quota, it had already been included in the time for repairs to the furnace within the time for refining. The length of the quota assigned for the heating of the furnace is fixed by each plant itself.

7. Furnace working rate

This refers to the percentage of the time spent in the working of the furnace itself in relation to the calendar working time. The formula is:

$$\begin{aligned} & \text{Furnace working rate (percent)} \\ & = \frac{\text{furnace working time during report period}}{\text{calendar working time during report period}} \times 100 \end{aligned}$$

8. Cold repair rate

This refers to the percentage of the time spend in cold

repairs in relation to the calendar working time. The formula is:

Cold repair rate (percent)

$$= \frac{\text{time spent in cold repairs during report period}}{\text{calendar working time during report period}} \times 100$$

The cold repair time includes the entire time spent in the general repair, medium repair and small repair of the open-hearth furnace. Each cold repair period starts with the suspension of the transmission of gas into the furnace, and ends with the completion of the repair and the start of the feeding of materials for the first heat of steel.

9. Rate of accepted open-hearth steel

This refers to the percentage of steel conforming with specifications produced by the open-hearth furnace (including accepted steel ingots and accepted liquid casting steel) in relation to the entire gross output (including the entire output of steel ingots and liquid steel). The formula is

Rate of accepted open-hearth steel (percent)

$$= \frac{\text{accepted steel output (accepted ingots + accepted liquid)}}{\text{total output (accepted output + rejects)}} \times 100$$

10. Rate of accepted steel ingots of open-hearth

This refers to the percentage of steel ingots conforming with specifications in relation to total output of ingots, viz:

Rate of accepted open-hearth steel ingots (percent)

$$= \frac{\text{accepted steel ingots}}{\text{total ingot output (accepted ingots + non accepted ingots)}}$$

$\times 100$

11. Open-hearth Steel Standards Promulgated by Ministry of Metallurgical Industry (in dispatch serial number Yeh-Kang 128 of 1958)

Brands of Steel	Grading as Provided in "Chung" 4-55					
	Grade One		Grade Two		Grade Three	
	sulphur	phosphorus	sulphur	phosphorus	sulphur	phosphorus
九, 友九	< 0.060	< 0.070	< 0.080	< 0.080	< 0.120	< 0.090
九 1-7 友九 1-7	< 0.055	< 0.050	< 0.070	< 0.060	< 0.100	< 0.080

Note: for contents of carbon, manganese and silica, and physical functions, see standard provisions promulgated by Ministry.

12. Average Steel output per heat

The calculating formula is:

$$\text{open hearth steel output per heat (ton)} = \frac{\text{total output of accepted steel during period}}{\text{total no. of heats of steel during period}}$$

13. Average refining time per heat

The calculating formula is:

$$\text{open hearth refining time per heat (hours minutes)} = \frac{\text{actual steel refining time during period}}{\text{total no. of heats of steel during period}}$$

To facilitate comparisons between different plants, the calculating unit of the average time for the refining of one heat of steel is to be given in hours and minutes.

14. Consumption of raw materials and fuel by open-hearth steel unit

This refers to the consumption volume of a certain raw material or fuel in the production of one ton of accepted open hearth steel. The formula is:

$$\text{open hearth steel unit consumption of raw materials} = \frac{\text{total consumption of raw materials and fuel for output}}{\text{output of accepted steel}}$$

15. Consumption of metal materials by open hearth steel unit

Metal materials include iron and steel materials, iron alloys and iron mineral deposits, as well as the amount of iron contained in ferric phosphorus. Consumption of metal materials by open hearth steel unit refers to the amount of metal materials consumed for the production of one ton of accepted open hearth steel. For the calculating formula, consult the formula for open hearth steel unit consumption of raw materials and fuel.

FOR REASONS OF SPEED AND ECONOMY
THIS REPORT HAS BEEN REPRODUCED
ELECTRONICALLY DIRECTLY FROM OUR
CONTRACTOR'S TYPESCRIPT

THIS PUBLICATION WAS PREPARED UNDER CONTRACT TO THE
UNITED STATES JOINT PUBLICATIONS RESEARCH SERVICE,
A FEDERAL GOVERNMENT ORGANIZATION ESTABLISHED
TO SERVICE THE TRANSLATION AND RESEARCH NEEDS
OF THE VARIOUS GOVERNMENT DEPARTMENTS