

REPORT DOCUMENTATION PAGE

Form Approved
OMB No. 0704-0188

Public reporting burden for this collection of information is estimated to average 1 hour per response, including the time for reviewing the collection of information. Send comments regarding this burden estimate or any other aspect of this collection of information, including suggestions for reducing this burden, to Washington Headquarters Services, Directorate for Information Operations and Reports, 1215 Jefferson Davis Highway, Suite 1204, Arlington, VA 22202-4302, and to the Office of Management and Budget, Paperwork Reduction Project (0704-0188), Washington, DC 20503.

1. AGENCY USE ONLY (Leave Blank)	2. REPORT DATE September 1998	3. REPORT TYPE AND DATES COVERED Final Report	
4. TITLE AND SUBTITLE Automatic Derivation of Traditional Anthropometric Measurements from Whole Body Scan Data		5. FUNDING NUMBERS N68335-98-C-0119	
6. AUTHOR(S) Glen Geisen; Terry Fulbright			
7. PERFORMING ORGANIZATION NAME(S) AND ADDRESS(ES) SYTRONICS, Inc. 4433 Dayton-Xenia Road; Bldg 1 Dayton OH 45432-1949		8. PERFORMING ORGANIZATION REPORT NUMBER SYT-765-001	
9. SPONSORING/MONITORING AGENCY NAME(S) AND ADDRESS(ES) Dept. of the Navy ATTN: Ms. Wendy L. Todd-Code 4.6.3.1 Naval Air Warfare Center-Aircraft Division 48110 Shaw Road, Unit 5, M/S Bldg. 2187 Patuxent River MD 20670-1906		10. SPONSORING/MONITORING AGENCY REPORT NUMBER	
11. SUPPLEMENTARY NOTES			
12a. DISTRIBUTION/AVAILABILITY STATEMENT Approved for public release; distribution unlimited		12b. DISTRIBUTION CODE	
13. ABSTRACT (Maximum 200 words) This paper reports the results of a study to determine feasibility of reliably extracting measurement information from whole body scan data for the use in tailor or garment fitting. The objective is to demonstrate an innovative, yet sound approach and solution. The information presented provides conclusive evidence that accurate and repeatable clothing measurements are extractable from this type of data without the use of pre-marked landmarks or operator intervention, either during the scanning or measurement process.			
19981214 069			
14. SUBJECT TERMS Anthropometric Measurement Segmentation Point Cloud Whole Body Scan 3D Scanning Automated Measurements		15. NUMBER OF PAGES 21	
		16. PRICE CODE N/A	
17. SECURITY CLASSIFICATION OF REPORT Unclassified	18. SECURITY CLASSIFICATION OF THIS PAGE Unclassified	19. SECURITY CLASSIFICATION OF ABSTRACT Unclassified	20. LIMITATION OF ABSTRACT UL

SYT-765-001

**Automatic Derivation of Traditional Anthropometric
Measurements from Whole Body Scan Data
Final Report**

Glen Geisen
Terry Fulbright

SYTRONICS, Incorporated

1998

**Department of the Navy
Naval Air Warfare Center – Aircraft Division**

This Final Report includes data that shall not be disclosed outside the Government and shall not be duplicated, used or disclosed (in whole or in part) for any purpose other than to evaluate this Report. The Government shall have the right to duplicate, use, or disclose the data to the extent provided in the resulting contract. This restriction does not limit the Government's right to use information contained if these data are obtained from another source with restriction.

SYT-765-001

**Automatic Derivation of Traditional Anthropometric
Measurements from Whole Body Scan Data
Final Report**

Prepared by
Glen Geisen
Terry Fulbright

SYTRONICS, Incorporated
4433 Dayton-Xenia Road, Building 1
Dayton, Ohio 45432

September 1998

Contract N68335-98-C-0119

Prepared for
Department of the Navy
Naval Air Warfare Center – Aircraft Division
48110 Shaw Road, Unit 5, M/S Building 2187
Patuxent River, Maryland 20670-1906

CONTENTS

Section	Title	Page No.
	List of Illustrations.....	iii
	List of Tables.....	iii
	Acknowledgements.....	iv
	Acronyms.....	v
1.	Summary.....	1
2.	Introduction.....	1
3.	Methods, Assumptions, and Procedures.....	1
3.1	Data Collection.....	1
3.2	Data Preprocessing.....	2
3.3	Data Visualization.....	2
3.4	Assumptions.....	2
3.5	Measurement Extraction Approach.....	2
3.6	Overview of the Technique.....	3
3.6.1	Computing Vectors to Define the Stick Figure.....	3
3.6.2	Extraction of Data Corresponding to Specific Stick Figure Data.....	7
3.6.3	Obtaining Measurements from the Extracted Data.....	7
3.7	Measurement Definitions.....	8
3.7.1	Seated Measurement Descriptions.....	8
3.7.2	Measurement – Segment Summary.....	9
3.7.3	Standing Measurement Descriptions.....	9
3.7.4	Measurement – Segment Summary.....	10
3.8	Results and Discussions.....	10
3.9	Obtaining Ellipse Centroids.....	10
3.10	Centroid Vector Construction.....	11
3.11	Segmentation.....	12
3.12	Measurement Extraction.....	13
4.	Conclusions.....	13
5.	Recommendations.....	13
6.	References.....	14
	Index.....	15

LIST OF ILLUSTRATIONS

Figure	Title	Page No.
1	Point Cloud Data	2
2	Human Cylinder Form.....	3
3	Centroids.....	4
4	Ellipses Produced by the DLSFE Algorithm.....	4
5	Data Points of an Ellipse Fit	5
6	Example of Centroid "Climbing"	6
7	Generating Vectors from the Centroid Data.....	6
9	Smoothed Centroids	11
8	Ellipse Centroids Along the Z-Axis	11
10	Centroid Vector Results.....	12
11	Data Segment to Support Buttock-Knee Length Measurement	13

LIST OF TABLES

Table	Title	Page No.
1	Segment Requirements for Measurements	9
2	Segment Requirements for Standing Measurements.....	10

ACKNOWLEDGEMENTS

The authors would like to thank several people and organizations for their assistance in making this project a success: our sponsors, Ms. Wendy Todd, US Navy NAWCAD and Mr. Brian Corner, US Army NATIK for their enthusiastic support and confidence; David Bruner and the Textile and Clothing Technology Corporation for the use of their whole body scanning system to collect the subject data; Andrew Fitzbibbon, Maurizio Pilu and Robert Fisher at The University of Edinburgh for their new approach to well-behaved ellipse fitting to scattered data; and Vince Schmidt, *Sytronics, Inc.* for his insight and diligence during algorithm development.

ACRONYMS

3-D	Three-Dimensional
CCD	Charged Coupled Device
GLOVE	OpenGL Object Viewing Environment
I/O	Input / Output
MDI	Multiple Document Interface
MFC	Microsoft Foundation Class
OpenGL	Portable Software Interface To Graphics Hardware
PMP	Phase Measuring Profilometry
SBIR	Small Business Innovative Research
[TC] ²	Textile and Clothing Technology Corporation

1. Summary

We describe an approach to automatic segmentation and derivation of body size measurements from 3D whole body scan data without the aid of pre-placed markers.

2. Introduction

Sytronics, Incorporated, is pleased to submit this final report describing the methods and conclusions for the "Proof-of-Concept" research performed under Navy SBIR Topic N98-029, "Automatic Derivation of Traditional Anthropometric Measurements From Whole Body Scan Data." The US Navy opened up this topic to investigate the possibilities of reliably extracting measurement information from whole body scan data for the use in tailor or garment fitting.

The purpose of a Phase I SBIR is a "Proof-of-Concept." Our objective is to demonstrate an innovative, yet sound approach and solution to the Topic problem. It is our belief that the methods developed and presented here provide conclusive evidence that accurate and repeatable clothing measurements are extractable from this type of data without the use of pre-marked landmarks or operator intervention, either during the scanning or measurement process.

3. Methods, Assumptions, and Procedures

3.1 Data Collection. Three-dimensional (3-D) surface scan data for this research is provided by the Textile and Clothing Technology Corporation ([TC]²). The [TC]² scanning system is a visible light measurement system called Phase Measuring Profilometry (PMP)TM. A light source is used to project a sinusoidal pattern onto the surface of the object to be scanned. Differences in surface topology cause deformations of the sinusoidal pattern and are captured by six CCD cameras and stored on a computer. The resulting contour image files are processed and produce point cloud files of the scanned surface, as seen from each of the CCD cameras. The six PMP point cloud data files are combined into a single point cloud representing the scanned surface.

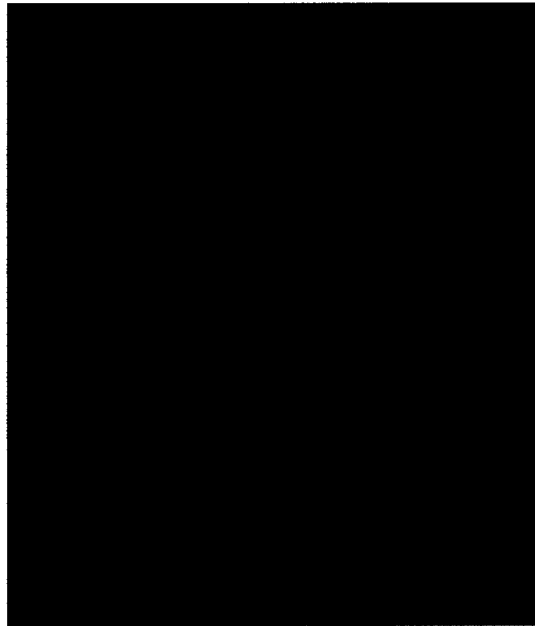

Figure 1. Point Cloud Data

3.2 Data Preprocessing. There is no preprocessing of the point cloud data as received from [TC]². All of the algorithms presented operated on the raw data provided or the intermediate output of another algorithm.

3.3 Data Visualization. Although visualization of the data and outputs are not specifically required for this project, a flexible viewer capable of displaying multiple independent or dependent objects comprising a large number of points or vectors was necessary to view intermediate and final results. The GL Object Visualization Environment (GLOVE) was developed to meet these needs.

GLOVE is based on OpenGL and uses the Microsoft Foundation Class (MFC) Multiple Document Architecture (MDI). GLOVE can read raw XYZ-point files that are either comma or space delimited, such as the TC² point cloud data. In addition, GLOVE uses its own object file format that is optimized for flexibility and readability. By default, the GLOVE object file format is ASCII, but can be binary for I/O performance considerations.

3.4 Assumptions. The point cloud is free of stray noise data (significantly) off the surface of the subject. No marks could be placed on the body before the scanning procedure.

3.5 Measurement Extraction Approach. We have identified two potential approaches to extracting measurements from scan data without the aid of pre-placed markers: templates and segmentation. The template-based approach involves the generation of either a deformable 3-D template or several templates of the body, from which to match subject data. In one case, the deformable template is distorted to fit the data. With an “atlas” of several templates, the data are matched to the closest fitting template. Once a tolerable match is achieved, landmarks can be encoded into the template(s) from which measurements can be obtained. In either case, complex

neural or genetic algorithms may be required to optimally distort shape information to select a match. In addition, a large number of training data are required to generate statistically accurate templates. Although this approach has merit, the foreseen need of a large number of data sets is not available within the limited schedule of the SBIR.

Our approach is to segment the point cloud data into a collection of cylinders. Each cylinder encapsulates data for a specific region of the body. The desired measurements can be made based on a combination of one or more of these cylinders.

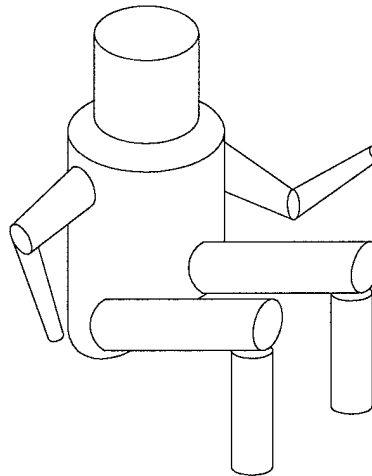

Figure 2: Human Cylinder Form

3.6 Overview of the Technique. The technique we've developed involves the definition of a representative 3-D “stick figure” within the point cloud data. Each stick figure is computed dynamically and is unique to the point cloud data in use. The stick figure is comprised of a collection of vectors within the point cloud data. Once the stick figure is computed, the portions of the point cloud data related to the specific stick figure vectors can be extracted and used for additional computation. This data, along with the corresponding vectors used for extraction, defines the basis for the cylinder(s) used in measurement. As described here, the process is essentially broken down into these areas, described in turn:

- Computing vectors to define the stick figure,
- Extraction of data corresponding to specific stick figure data, and
- Obtaining measurements from the extracted data.

3.6.1 Computing Vectors to Define the Stick Figure. A stick figure can be created by finding centroids, then combining the results (using linear regression or similar methods) into line segments or vectors. This illustration demonstrates centroids collected orthogonal to the figure's major axis, and shows the resulting line segment defined by the centroids. A similar approach can be taken with ellipse data. Centroids can be collected from multiple ellipses, then combined into line segments or vectors. The image shown here illustrates this point. Sequential ellipse centroids form a “path” through the data set, representing the centroid of each cylinder. This method provides the cylinder centroids upon which segmentation decisions are based.

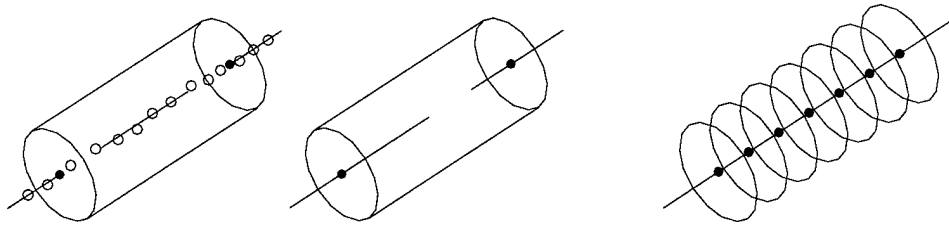

Figure 3. Centroids

We must compute ellipses from point data if we want to use ellipse centroids. A method called “Direct Least Squares Fitting of Ellipses” [**] (DLSFE) guarantees the computation of an ellipse when provided with point data (other methods may produce non-ellipsoid results for “interesting” data; see reference for details). The figure shown here demonstrates the ellipses produced by the DLSFE algorithm for:

- Highly elliptical data (A),
- Noisy highly elliptical data (B),
- Only a few points of elliptical data (C),
- Results of multiple groups of data (D), and
- Results when a significant outlier is present (E).

Note that illustration (D) and (E) do not portray optimal results for this application, but these effects will not generally cause undue stress to the application at hand.

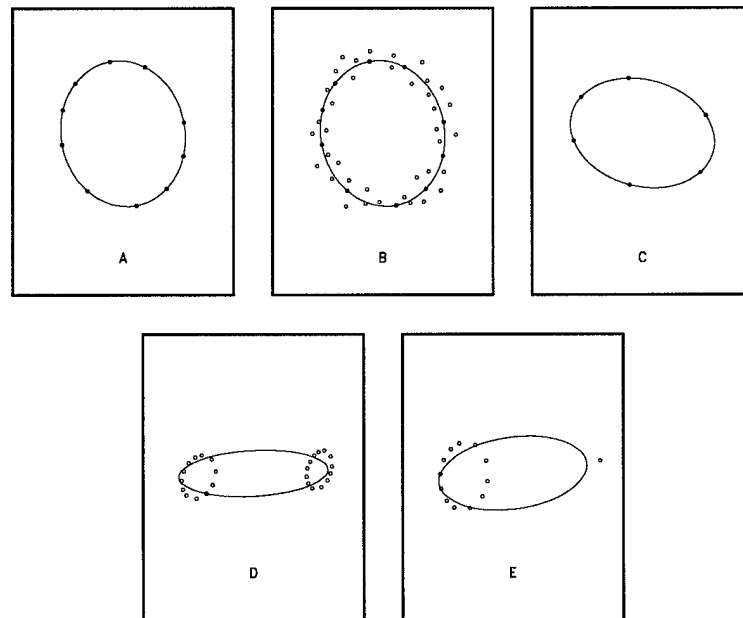

Figure 4. Ellipses Produced by the DLSFE Algorithm

The DLSFE algorithm does require a “reasonable number” of points (in the neighborhood or 10 to 20) for finding a good ellipse fit. Our implementation uses three user-adjustable mechanisms to guarantee a sufficient number of data points are available for fitting ellipses. Data are processed in “slices” (all data with a specified Z-coordinate) orthogonal to the working axis¹ collected an entire slice at a time. The user may specify the minimum number of data points that must be present for ellipse fitting (default value is ten data points), the minimum number of data slices to include (default is one level of data), and the minimum total height of the data column collected (the default is zero units of height, the difference between the minimum and maximum Z-coordinates for the data included). Consecutive slices of data are collected until the criteria above are met. The resulting data are “collapsed” (that is, the Z-component is ignored) and an ellipse is fit to the collected data. The accompanying figure illustrates this procedure.

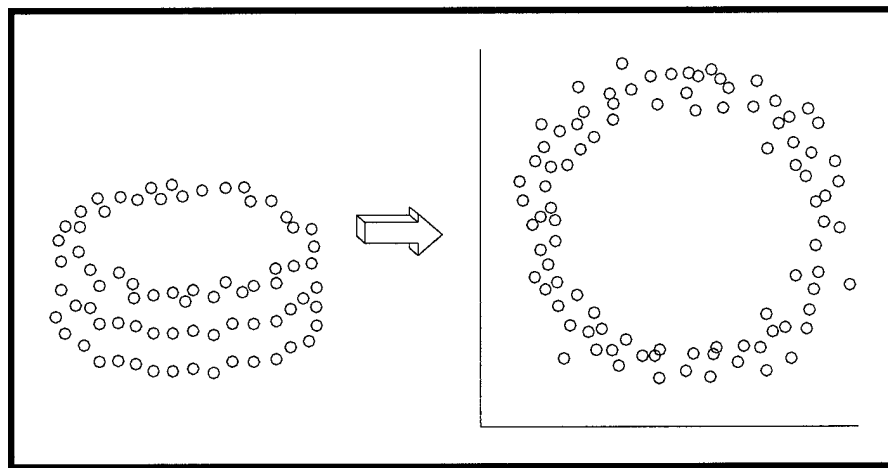

Figure 5. Data Points of an Ellipse Fit

Collecting this centroid data can be described as “climbing” the data's working axis; data from several levels is “collapsed” as discussed above, an ellipse is fit to the collapsed data, ellipse parameters are saved (as if belonging to a specific level of Z), and the procedure is executed from the next level of the working axis. The process continues until all data has been processed and centroids have been found. The collection of these centroids is monotonically increasing in the direction of the working axis.

¹ Internally, the working axis is always the Z-axis. This is because the data may be processed orthogonal to the X-, Y-, or Z-axis, and the application automatically rotates the data and re-labels each axes such that the algorithm is always processing along the Z-axis.

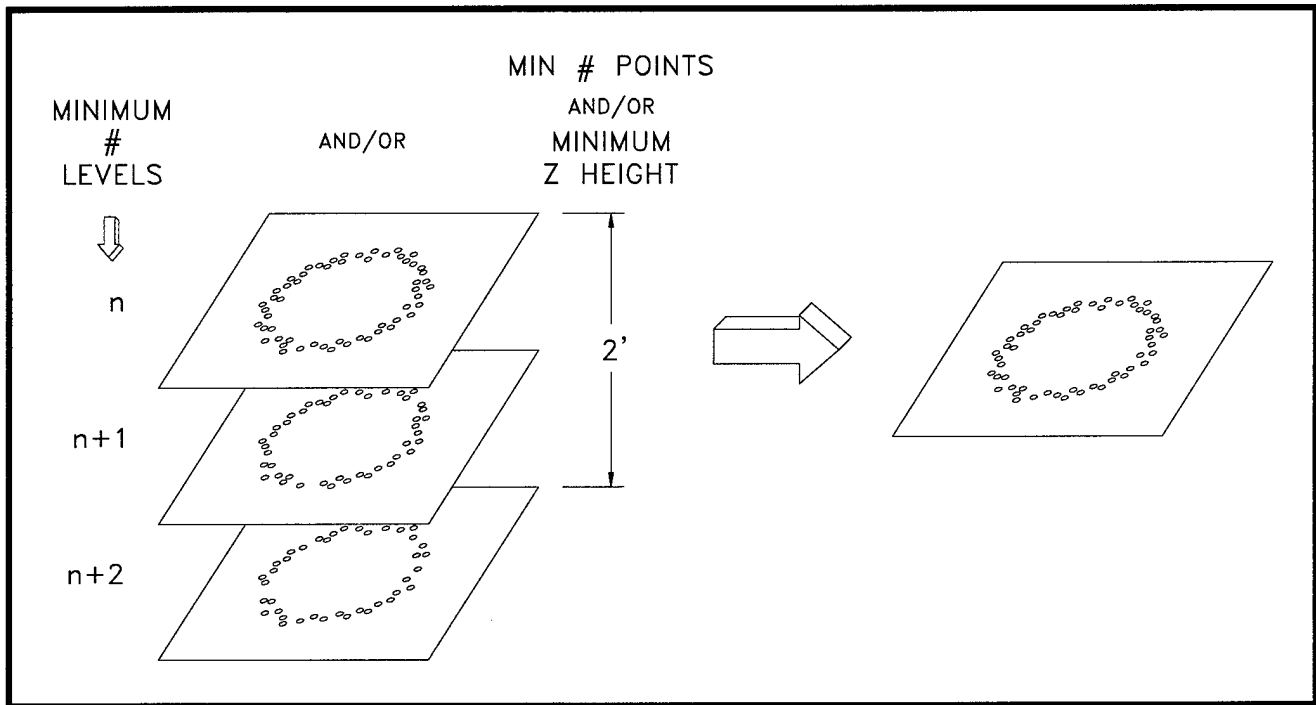

Figure 6. Example of Centroid "Climbing"

Once all centroids have been computed, a smoothing filter is applied to dampen the effects of outliers and rough edges. "Very small" vectors (whose sizes depend on user option, defaulting to 15 units in the direction of the working axis) are created from the centroid data. These small vectors are merged into larger vectors. We use a simple vector-merging algorithm that merely adds two adjacent vectors if the angle between them does not exceed some deadband degree, a user-definable number, defaulting to 20 degrees. These larger vectors define the stick figure corresponding to the original point cloud data. Illustrations included here clarify these points.

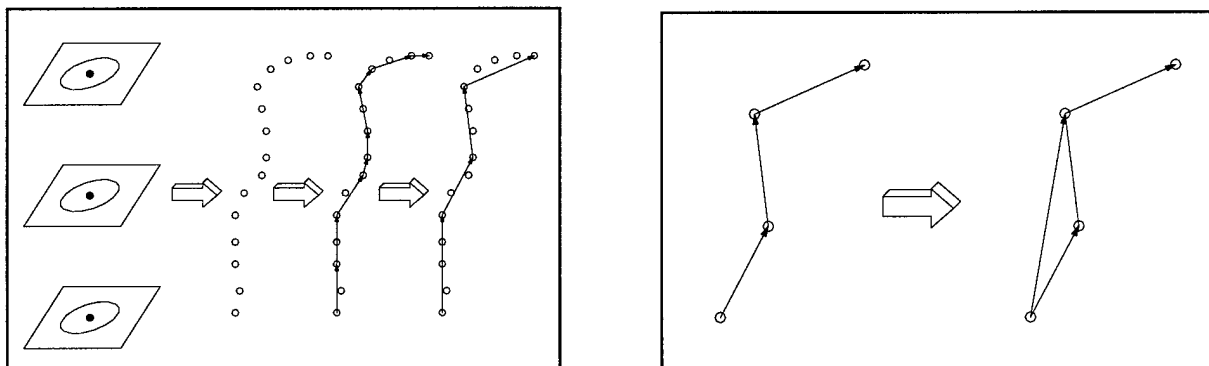

Figure 7. Generating Vectors from the Centroid Data

The second method uses a robust linear regression technique that fits a line to the centroids by minimizing absolute deviation². To begin, small vectors are approximated for the centroids. Again a deadband threshold is used, but this method considers the angular difference in slope between two adjacent vectors to determine if the vectors should be merged. The resulting output is a stick figure that approximates a best path through the centroids.

3.6.2 Extraction of Data Corresponding to Specific Stick Figure Data. Stick figure information provides the means required for cloud data segmentation. Recognizing the cloud data corresponding to the line segment endpoints permits us to extract the relevant portion of data into a separate file for additional processing. The simplest way to automate such extraction is to develop a simple set of heuristics allowing definition of the stick figure line segments to be included in the extraction. We have developed several simple heuristics as a demonstration and proof-of-concept.

The heuristics “language” is very simple, consisting of only four major commands (*start*, *stop*, *move*, and *model*) and a few sub-commands. A “program” written in this heuristic language is typically very short (less than 25 characters long). The sole purpose of this language is to describe the nature of the line segments (and thus the corresponding point cloud data) to be included for extraction.

Stick figure vectors are traversed sequentially, beginning with the first vector in the stick figure. The *start* and *stop* command begin and end the inclusion of vectors, respectively. *Move* and *model* (and their subcommands) are used to conditionally traverse the vector list, including vectors as they go.

3.6.3 Obtaining Measurements from the Extracted Data. Measurements are obtained from the original point cloud using the stick figure to traverse and identify body segments. The point cloud is segmented into many well-defined pieces that enable an almost trivial measurement extraction. For example, consider the seated, buttock-knee length measurement: the stick figure is used to segment the data until only the right buttock-thigh-knee data remain. From this small segment, the buttock-knee length becomes a simple horizontal measure of the extents of the remaining point cloud data at the centroid of the thigh.

Similarly, each measurement can be defined by a method of measurement (length, orientation, circumference, point-to-point) and the segment that contains the data required to support the measurement.

² Press, W., et al., Numerical Recipes in C: The Art of Scientific Computing, 2nd Edition, pp703-705

3.7 Measurement Definitions. Traditional anthropometric measurements are based mostly on sub-surface landmarks³. Obviously sub-surface information is unavailable to the surface scanning modality. Consequently, measurements must be defined in terms of reliable (and obtainable) body surface features.

3.7.1 Seated Measurement Descriptions.

- **Buttock Knee Length:** From the front of the knee to the buttock, along the thigh centroid.
- **Abdominal Extension Depth, Sitting:** Horizontal length, from the anterior abdomen through to the back.
- **Knee Height, Sitting:** The vertical distance from the footrest surface to the centroid top penetration point through the knee surface.
- **Hip Breadth, Sitting:** The most lateral points on the hips or thighs, whichever is broader.
- **Popliteal Height:** The vertical distance from the footrest surface to the bottom surface of the thigh at the knee intersection.
- **Acromion Height:** The vertical distance from the sitting surface to the vertical projection point of the arm-torso segmentation plane.
- **Sitting Height:** The vertical distance from the sitting surface to the top of the head.
- **Thigh Clearance:** The vertical distance from the sitting surface to the highest point of the thigh, before the trunk intersection.
- **Shoulder Circumference:** The torso surface circumference at the arm centroid height.

³ Clauser, Tebbetts, Bradtmiller, McConville, and Gordon (1988) *Measurer's Handbook*; US Army Anthropometric Survey, Natick Technical Report TR-88/043; Name Anthropometric Source book 1024; DoD-HDBK-743

3.7.2 Measurement – Segment Summary.

TABLE 1
Segment Requirements for Measurements
* - Centroid endpoint required

	LEGS	RIGHT LEG	RIGHT ARM	TORSO
Buttock Knee Length		✓		
Abdominal Extension Depth, Sitting		✓		
Knee Height, Sitting		✓		
Hip Breadth, Sitting	✓			
Popliteal Height		✓		
Acromion Height			✓	
Sitting Height				✓
Thigh Clearance		✓		
Shoulder Circumference			*	✓

3.7.3 Standing Measurement Descriptions.

- Sleeve Length: The top surface length of the right arm from the vertical projection of the arm centroid endpoint to the tip of the finger surface.
- Crotch Height: The vertical distance from the standing surface to the lowest thigh intersection point at the crotch.
- Back Waist Length: The vertical distance from the height of the natural minimum waist indentation to the cervicale.
- Chest Circumference: The horizontal surface circumference at the lower surface penetration of the arm centroid upper-most end point.
- Shoulder Circumference: The torso surface circumference at the arm centroid height.
- Waist Circumference: The horizontal surface circumference at the natural minimum waist indentation.
- Buttock Circumference: The horizontal surface circumference at the height of the maximum protrusion of the right buttock.
- Neck Circumference: The minimum surface circumference around the neck, below the chin.

3.7.4 Measurement – Segment Summary.

**TABLE 2
Segment Requirements for Standing Measurements**

	LEGS	RIGHT ARM	TORSO
Sleeve Length		√	
Crotch Height	√		
Back Waist Length			√
Chest Circumference		*	√
Shoulder Circumference		*	√
Waist Circumference			√
Buttock Circumference			√
Neck Circumference			√

3.8 Results and Discussions. The following section describes the specific results of the methods and approach described when applied to the test data.

3.9 Obtaining Ellipse Centroids. With a multi-pass approach, the data are first “rough-fit” with the estimation of ellipses along the X-, Y-, and Z-axis. Point cloud data are collapsed by intervals along the axis of interest. The interval size is controlled by several parameters:

- The minimum height in millimeters of the interval,
- The minimum number of points to collect for ellipse estimation, and
- The minimum different levels (in Z) to collapse.

Interval data are collapsed to a single plane and the resulting bi-coordinate points are used to estimate an ellipse, noting its major axis, minor axis, and centroid. This process is repeated along the length of the axis, resulting in a collection of ellipse centroid points. The centroids are filtered with a smoothing kernel to (clean) the data.

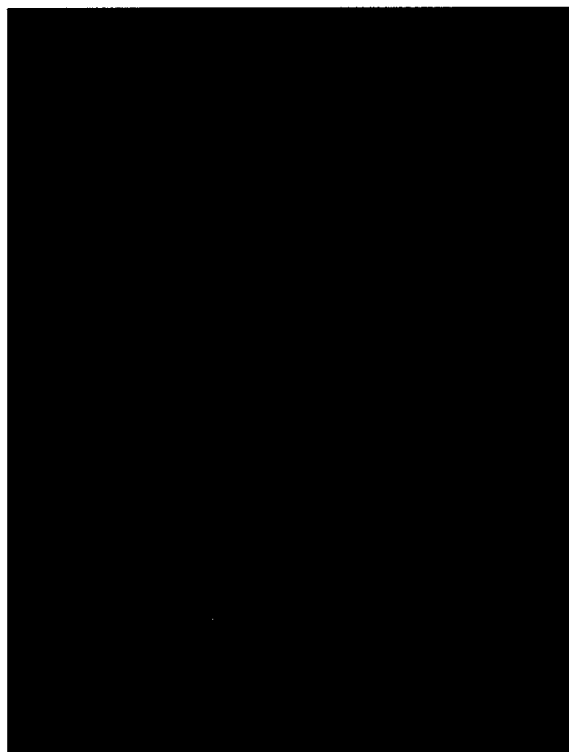

Figure 8. Ellipse Centroids Along the Z-Axis

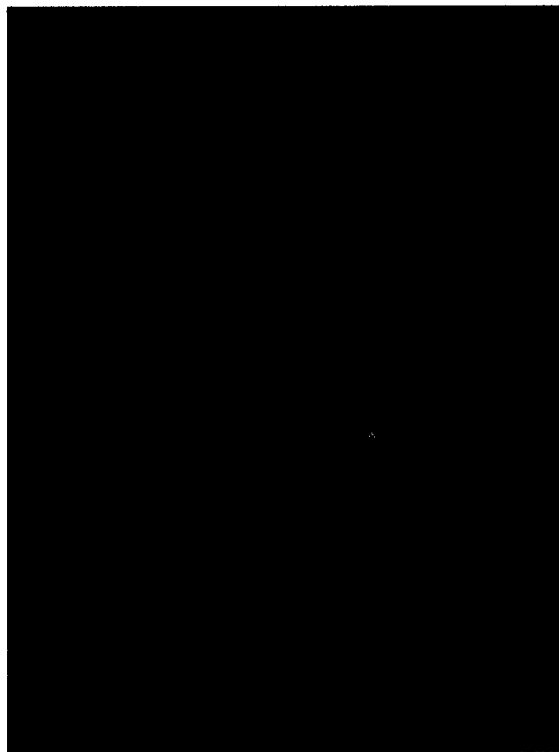

Figure 9. Smoothed Centroids

3.10 Centroid Vector Construction. Next, the connection of adjacent ellipse centroids form directional vectors that represent moving cylinder centroids (describing) the interval cylinders estimated from the point cloud data. To build these vectors, initial vectors are sequentially constructed from adjacent points, until the minimum vector length is obtained (15 mm). The nth vector is added to the n-1 vector if its direction is within a selected number of degrees, called the deadband limit (default = 20°). If the vector-to-vector deadband is greater than the deadband limit, the construction of the current vector stops, and a new one starts. This process is repeated until all centroid data points have been assimilated into vectors. The resulting representation is similar to a stick figure of the ellipse centroids through the human body.



Figure 10. Centroid Vector Results

3.11 Segmentation. The centroid vectors (stick figure) is used to segment the data into the required sub-segments for each measurement

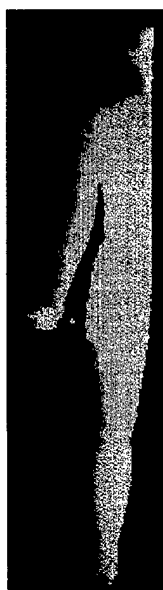
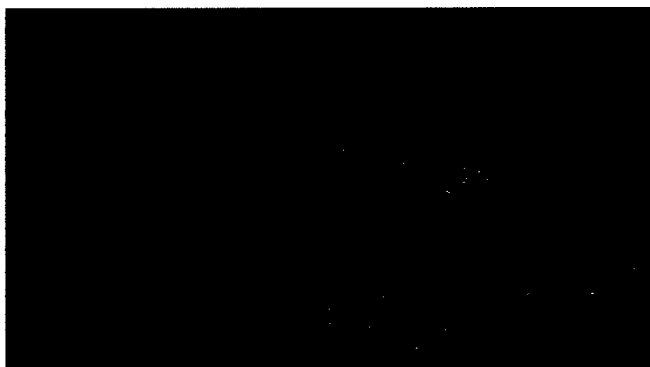
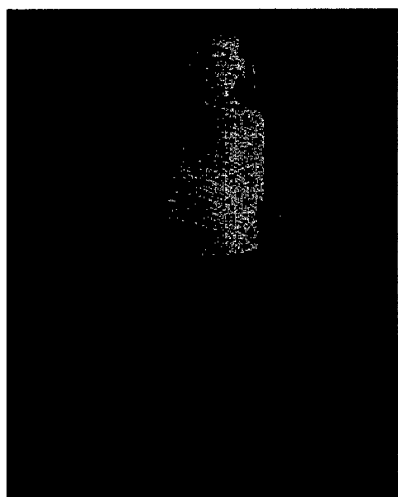

3.12 Measurement Extraction. As described earlier, for the buttock-knee length, the data to support the measurement is the right buttock-thigh-knee segment. Once the segment has been successfully obtained, as below, the measurements are obtained directly from the point cloud.

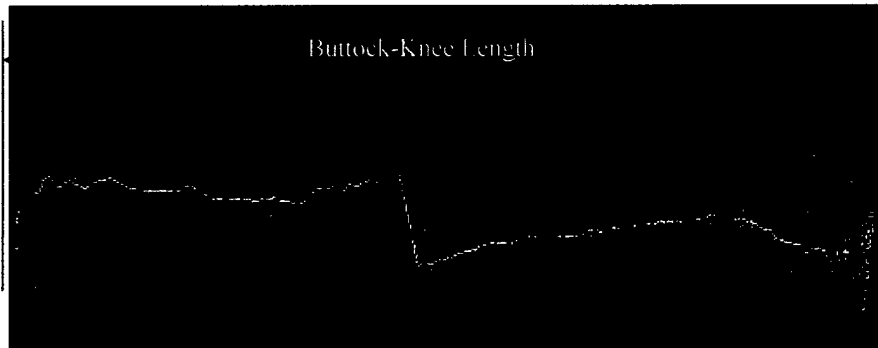

Figure 11. Data Segment to Support Buttock-Knee Length Measurement

In this case the extracted measure was repeatable within four millimeters (4mm) of the manual measurement.

4. CONCLUSIONS

From the investigations performed and the concepts developed, it is our conclusion that repeatable body size measures can be automatically extracted from this type of data.

5. RECOMMENDATIONS

There are several areas that warrant further research that simply was not possible given the time and resource constraints of a short six month SBIR.

- Complete automation of the segmentation process.
- Definition of all measurements with respect to how each measurement must be taken and the minimum data required.
- Complete automation of the measurement process.
- Although we achieved acceptable results as compared to sample manual measurements, a validation study needs to be carefully performed.
- An important discovery was observed during this investigation. Using the centroid technique described, different bodies exhibit similar “signatures” when the centroid vectors are created. Further investigation of this phenomenon could lead to a signature analysis approach that would be very robust in identifying physical body features, leading to segmentation.

6. REFERENCES

- Fitzgibbon, A., Pilu, M., Fisher, R., *Direct Least Squares Fitting of Ellipses*, Department of Artificial Intelligence, The University of Edinburgh, Scotland, January 1996
- Press, W., et al., *Numerical Recipes in C: The Art of Scientific Computing*, 2nd Edition, pp703-705.
- Clauser, Tebbetts, Bradtmiller, McConville, and Gordon (1988) *Measurer's Handbook; US Army Anthropometric Survey*, Natick Technical Report TR-88/043; Name Anthropometric Source book 1024; DoD-HDBK-743

INDEX

A

ACKNOWLEDGEMENTS, iv
ACRONYMS, v
Assumptions, 2

C

Centroid Vector Construction
 See Figure 10
 Centroid Vector Results, 11
Computing Vectors to Define the Stick Figure
 See Figure 3
 Centroids, Figure 4
 Ellipses Produced by the DLSFE Algorithm,
 Figure 5
 Data Points of an Ellipse Fit, Figure 6
 Example of Centroid, 3

CONCLUSIONS, 13

D

Data Collection
 See Figure 1
 Point Cloud Data, 1
Data Preprocessing, 2
Data Visualization, 2

E

Extraction of Data Corresponding to Specific Stick Figure
 Data, 7

I

INTRODUCTION, 1

M

Measurement – Segment Summary
 See Table 1
 Segment Requirements for Measurements, 9
 See Table 2
 Segment Requirements for Standing Measurements,
 10
Measurement Definitions, 8
Measurement Extraction
 See Figure 11
 Data Segment to Support Buttock-Knee Length
 Measurement, 13
Measurement Extraction Approach
 See Figure 2
 Human Cylinder Form, 2
METHODS, ASSUMPTIONS, AND PROCEDURES, 1

O

Obtaining Ellipse Centroids
 See Figure 8
 Ellipse Centroids along the Z-Axis and Figure 9
 Smoothed Centroids, 10
Obtaining Measurements from the Extracted Data, 7
Overview of the Technique, 3

R

RECOMMENDATIONS, 13
REFERENCES, 14
Results and Discussions, 10

S

Seated Measurement Descriptions, 8
Segmentation, 12
Standing Measurement Descriptions, 9
SUMMARY, 1