

AD_____

GRANT NUMBER DAMD17-95-1-5060

TITLE: Integrated Remote Neurosurgical System

PRINCIPAL INVESTIGATOR: Hunter J. Downs, Ph.D.

CONTRACTING ORGANIZATION: Virginia Neurological Institute
Charlottesville, Virginia 22906

REPORT DATE: September 1998

TYPE OF REPORT: Final

PREPARED FOR: U.S. Army Medical Research and Materiel Command
Fort Detrick, Maryland 21702-5012

DISTRIBUTION STATEMENT: Approved for public release;
distribution unlimited

The views, opinions and/or findings contained in this report are those of the author(s) and should not be construed as an official Department of the Army position, policy or decision unless so designated by other documentation.

DTIC QUALITY INSPECTED 3

REPORT DOCUMENTATION PAGE

Form Approved
OMB No. 0704-0188

Public reporting burden for this collection of information is estimated to average 1 hour per response, including the time for reviewing instructions, searching existing data sources, gathering and maintaining the data needed, and completing and reviewing the collection of information. Send comments regarding this burden estimate or any other aspect of this collection of information, including suggestions for reducing this burden, to Washington Headquarters Services, Directorate for Information Operations and Reports, 1215 Jefferson Davis Highway, Suite 1204, Arlington, VA 22202-4302, and to the Office of Management and Budget, Paperwork Reduction Project (0704-0188), Washington, DC 20503.

1. AGENCY USE ONLY <i>(Leave blank)</i>	2. REPORT DATE September 1998	3. REPORT TYPE AND DATES COVERED Final (14 Aug 95 - 30 Aug 98)	
4. TITLE AND SUBTITLE Integrated Remote Neurosurgical		5. FUNDING NUMBERS DAMD17-95-1-5060	
6. AUTHOR(S) Downs, Hunter J., Ph.D.		8. PERFORMING ORGANIZATION REPORT NUMBER	
7. PERFORMING ORGANIZATION NAME(S) AND ADDRESS(ES) Virginia Neurological Institute Charlottesville, Virginia 22906			
9. SPONSORING / MONITORING AGENCY NAME(S) AND ADDRESS(ES) U.S. Army Medical Research and Materiel Command Fort Detrick, Maryland 21702-5012		10. SPONSORING / MONITORING AGENCY REPORT NUMBER	
11. SUPPLEMENTARY NOTES		19981214 106	
12a. DISTRIBUTION / AVAILABILITY STATEMENT Approved for public release; distribution unlimited		12b. DISTRIBUTION CODE	
13. ABSTRACT <i>(Maximum 200 words)</i> The Integrated Remote Neurosurgical System (IRNS) is a robotic neurosurgical microscope remotely-operated through the utilization of high-speed communications and a surgeon-accessible computer interface. The intended use of this system is for surgical mentoring of an operating-room (OR) surgical team by a remote expert surgeon. In the design of the IRNS, we emphasized giving the remote surgeon the feeling of actually being in the OR, a sense of telepresence, through the use of bidirectional audio, video whiteboarding on the microscope view, site cameras, voice recognition, bilateral access to the patient's images and an interface to our presurgical planning software. The IRNS also includes several methods to control the remote microscope and its functions including rotation, translation, focus, and zoom. Safety precautions are implemented including the condition that any remote manipulation of the scope is possible only when the local operator actively permits it by holding down a "dead man" switch. The remote and local OR sites are integrated using an asynchronous transfer mode (ATM) switched network link. The development of the IRNS has provided an opportunity to assess the benefits of remote surgical mentoring and to gain technical expertise in the area of teleoperation of surgical devices over switched networks.			
14. SUBJECT TERMS Telemedicine; Telerobotics; Neurosurgery; Remote Mentoring; Telepresence		15. NUMBER OF PAGES 22	
17. SECURITY CLASSIFICATION OF REPORT Unclassified		16. PRICE CODE	
18. SECURITY CLASSIFICATION OF THIS PAGE Unclassified	19. SECURITY CLASSIFICATION OF ABSTRACT Unclassified	20. LIMITATION OF ABSTRACT Unlimited	

FOREWORD

Opinions, interpretations, conclusions and recommendations are those of the author and are not necessarily endorsed by the U.S. Army.

X Where copyrighted material is quoted, permission has been obtained to use such material.

X Where material from documents designated for limited distribution is quoted, permission has been obtained to use the material.

X Citations of commercial organizations and trade names in this report do not constitute an official Department of Army endorsement or approval of the products or services of these organizations.

 In conducting research using animals, the investigator(s) adhered to the "Guide for the Care and Use of Laboratory Animals," prepared by the Committee on Care and Use of Laboratory Animals of the Institute of Laboratory Resources, National Research Council (NIH Publication No. 86-23, Revised 1985).

 For the protection of human subjects, the investigator(s) adhered to policies of applicable Federal Law 45 CFR 46.

X In conducting research utilizing recombinant DNA technology, the investigator(s) adhered to current guidelines promulgated by the National Institutes of Health.

X In the conduct of research utilizing recombinant DNA, the investigator(s) adhered to the NIH Guidelines for Research Involving Recombinant DNA Molecules.

X In the conduct of research involving hazardous organisms, the investigator(s) adhered to the CDC-NIH Guide for Biosafety in Microbiological and Biomedical Laboratories.

PI - Signature

9/24/98
Date

Table of Contents

FRONT COVER	1
SF-298	2
FOREWORD	3
TABLE OF CONTENTS	4
INTRODUCTION	5
IRNS SYSTEM ARCHITECTURE	7
OVERVIEW	7
COMMUNICATIONS DESIGN	9
OR WORKSITE	11
REMOTE WORKSITE	12
TASK ANALYSIS	16
ROBOT SIMULATION	16
ISSUES IN BILATERAL CONTROL OF TELEOPERATOR OVER ATM NETWORKS	16
DISCUSSION AND CONCLUSIONS	17
REFERENCES	20
PERSONNEL	21
PUBLICATIONS	22

Introduction

There is growing interest in the healthcare field for telemedicine, the use of teleconferencing technologies (bidirectional video and audio) to allow consultations between doctor and patient located in different places. Telemedicine reduces travel times for physicians and patients, and allows specialized healthcare to reach locations that might otherwise be underserved. With the growing acceptance of telemedicine comes the possibility of other types of remote medical intervention, such as remote surgery. Remote surgery, where one or more members of the surgical team are remotely located, is presently in its infancy. One of the prime motivators of this concept has been the United States Department of Defense, who saw the potential for far-forward battlefield medical intervention without placing highly valuable surgeons in danger. Presently, implementations consist of research systems in which a remote surgeon instructs (teleoperates) a robot for suturing or for micro-inspection.

We have constructed the Integrated Remote Neurosurgical System (IRNS), a remotely-operated neurosurgical microscope with high-speed communications and a surgeon-accessible user interface. The IRNS allows high quality bidirectional mentoring in the neurosurgical suite, enabling a remote neurosurgeon to lend expertise to the Operating Room-based (OR) neurosurgical team.

The IRNS uses a generic microscope/transport model, allowing the system to be useful for remote operation of a general class of operating room robots and video sources. In our case, the equipment is the Carl Zeiss [1] MKM surgical microscope/transport, with attached Zeiss OPMI stereo microscope (Figure 1). SuMIT (the Surgical Manipulator Interface Translator) performs translation from generic commands to hardware-specific transport commands in the OR. A SuMIT interface is planned for each device to be controlled by the IRNS.

To the remote surgeon, the most important aspect of the IRNS is the feeling of being present in the OR during the surgery. It is this sensation of telepresence that enables the remote surgeon to comfortably and confidently control the remote microscope and interact smoothly with the OR team. To be successful, telepresence systems must place a low cognitive load on the user by allowing him to interact with the system in a natural and familiar manner. For example, the use of bidirectional audio allows the users of a telepresence system to communicate verbally as they would in person. The addition of bidirectional video adds the information contained in facial expressions and gestures. This type of feedback is known to improve the interactivity of collaborative systems[2]. If other physical artifacts are present in the system, such as input devices with which the user interacts, they should be familiar in appearance and operation to those used under normal circumstances. In this manner our telepresence system can be useful and acceptable to the surgeon. As we will show, we have placed a strong emphasis on telepresence in the IRNS.

The IRNS remote workstation incorporates image-based surgical planning capabilities and can display real-time video from both the microscope and an overhead video camera. The overhead camera shows the remote surgeon the general layout of the OR and the relative locations of the OR team, the patient, and the robot. The IRNS also incorporates the ability to remotely control the microscope position, zoom, and focus. The remote workstation includes several methods for microscope control. The primary interaction method is a force-reflecting handgrip mounted on a 6-degree-of-freedom robot that allows the remote surgeon to intuitively position the microscope. Other features include bidirectional audio, image archiving, voice recognition, bidirectional whiteboarding, and an interface to our presurgical stereotactic planning system.

Real-time simulation of the microscope transport is provided by the commercially available Telegrip (Envision) simulation package from Deneb Robotics[3]. Telegrip/Envision is used to produce a realistic view of the OR robot as it is controlled from the remote workstation. The simulation permits pre-surgical simulation and training for surgeons without access to an actual microscope transport system.

The components of the IRNS are integrated using Asynchronous Transfer Mode (ATM)[4] switching to provide low latency data transfer. A registration system has been developed to ensure precise monitoring of the patient and microscope.

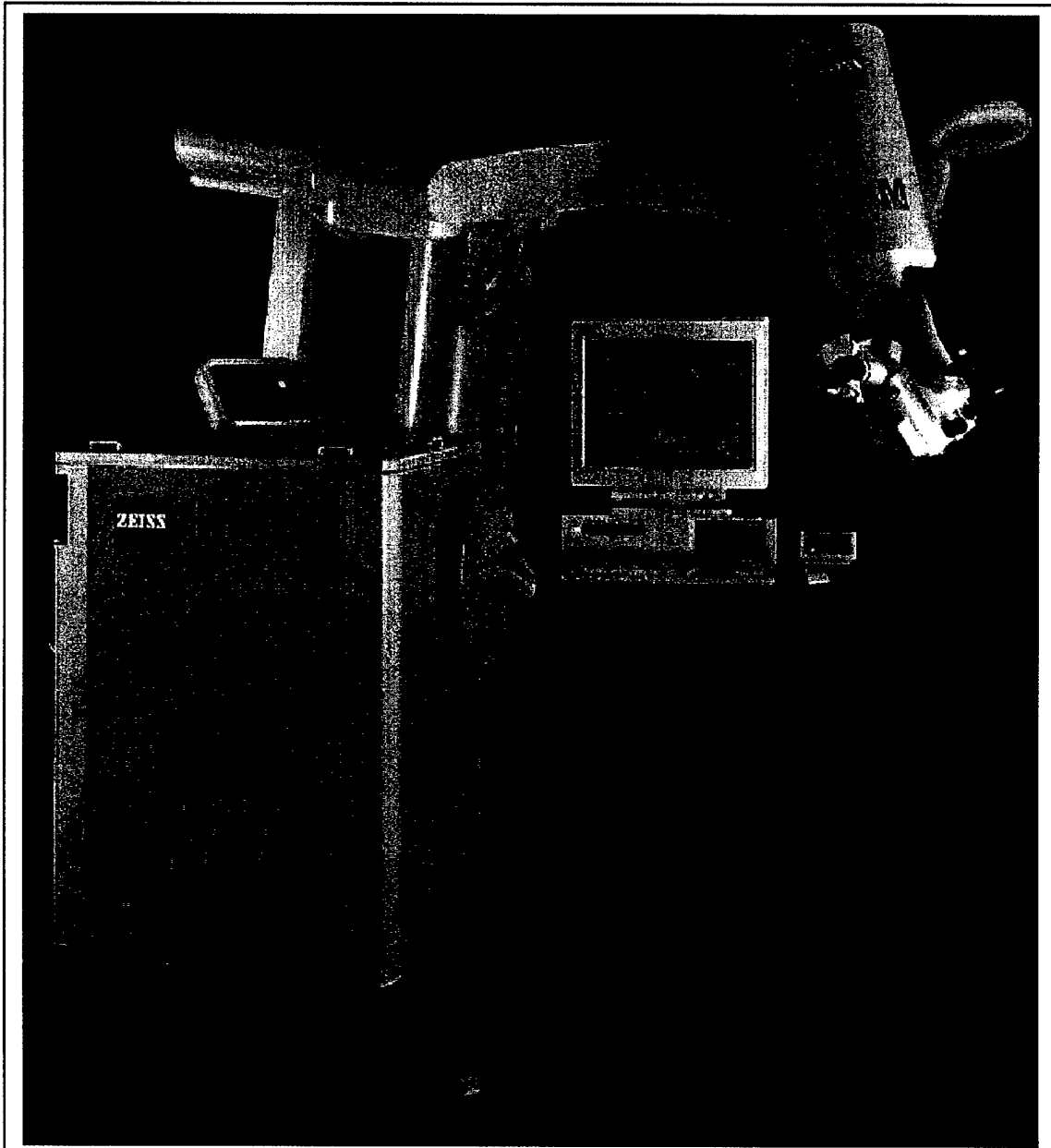

Figure 1. The MKM microscope transport

The IRNS provides an opportunity to assess the benefits of remote surgical mentoring and to gain technical expertise in teleoperation of surgical devices. By integrating high performance workstations and microscope carriers, the system demonstrates the usefulness of communications and computing resources in improving access to specialized surgical facilities. This research, along with the more sophisticated systems that will follow, serves as a foundation and testing platform for extending the surgeon's skills without regard to time zone or geographic boundaries.

This document will describe the IRNS in its current state, including the system architecture, communications architecture, safety guidelines, user interface, and hardware. We will then discuss the future research and development goals for the IRNS.

IRNS System Architecture

Overview

The IRNS consists of two worksites: the operating room and the remote workstation. They are connected via an ATM network (Figure 2). Each worksite hosts elements such as workstations and cameras. Locally, these elements are interconnected by ATM, Ethernet, or RS-232 connections, and are ultimately linked by a site workstation. The ATM link is responsible for carrying all video, audio, and control data. Currently, the remote workstation may control either

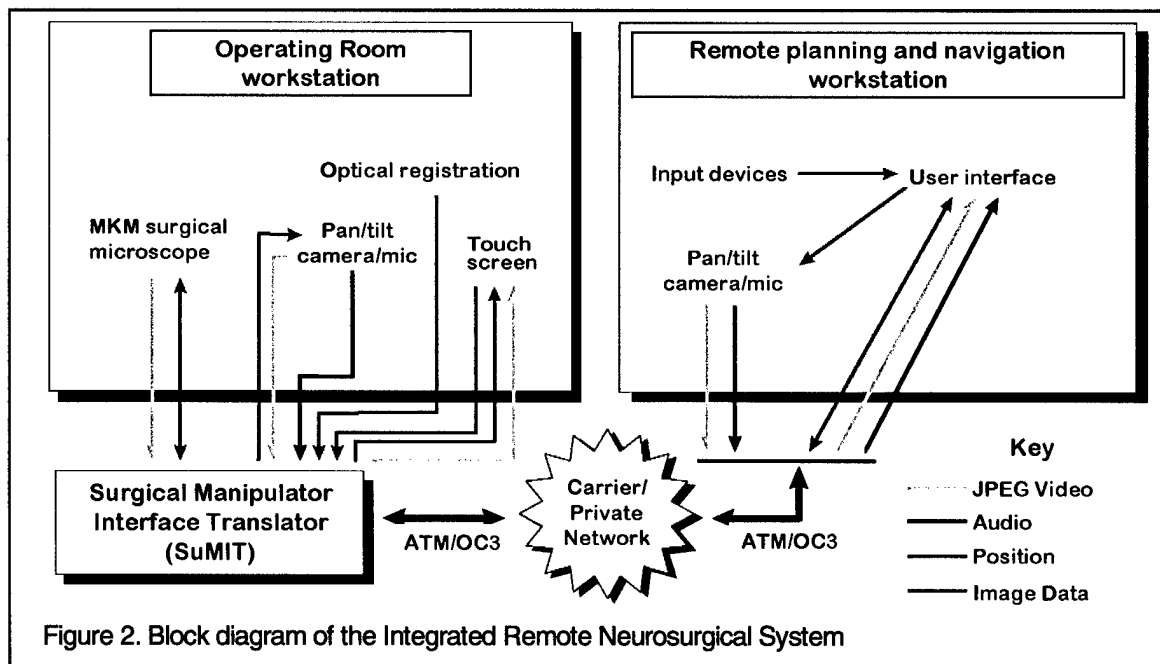

a simulated MKM (in Telegrip/Envision), a simulated Robotics Research (RR) 1607, an actual MKM or an actual RR1607. The MKM has been installed in the University of Virginia Health Sciences Center Hospital and in the first floor of the Virginia Neurological Institute (VNI). The RR1607 has been permanently mounted in an OR mockup within the Neurovisualization Lab on the third floor of the VNI building. The simulated MKM and RR1607 were used to test various components of the interface when either the actual robot was not available or when the testing

being done was potentially dangerous to the robot. These fully functional models, complete with forward and inverse kinematic, were also used to show the remote operator the current configuration of the actual robotic scope. The RR1607 is interfaced to a servo-controlled charge-coupled device (CCD) camera that is analogous to the OPMI stereo microscope. In conjunction with technical representatives of Carl Zeiss Inc., the project team developed a teleoperation interface to the MKM and integrated into the IRNS. All software and hardware shown in Figure 2, including the ATM network, room camera software, audio communications, and surgical planning user interface, have also been integrated into the IRNS.

In order to familiarize the reader with the IRNS, it is illustrative to present a simple scenario for its usage. A typical scenario for use of the IRNS consists of:

- microscope setup and positioning,
- session startup and connection to remote workstation,
- preliminary consultation between OR and remote physicians,
- commencement of surgery with remote physician observing and providing expertise,
- handoff of control of microscope between OR and remote physicians,
- remote control of microscope, including gross and fine motion, and
- session shutdown.

Each task in this list has now been developed in the IRNS. We will now examine each item in greater detail.

Microscope setup and positioning involves both microscope-specific tasks (such as driving the MKM transport into the OR and placing in position) and IRNS-specific tasks such as establishing the communications link between the microscope and the OR workstation. Microscope-specific tasks are performed first. For the MKM, setup includes physical positioning of the transport and the workstation in the OR, making the appropriate cabling connections, booting of the MKM workstation, and executing the MKM control software, and executing the MKM-IRNS link software. The setup phase also includes the establishment of the registration of the patient's position relative to the robot (a process known as registration). This software provides the IRNS generic interface to the MKM controller. Once the MKM-IRNS link software is running, the system is controlled generically using the IRNS.

The IRNS obtains the current robot position and the patient registration transformation from the MKM using the MKM-IRNS link software. This information is used for image-guided control of the microscope.

The remote workstation is connected to the OR workstation next. The method used to establish the communications link will be described in later sections; it is transparent to the users of the system in any case. Startup of the remote workstation software is performed simply by execution of a single UNIX command. Once the software is running, the remote surgeon will typically specify a patient's image data set and surgical plan to load.

Once the connection between sites has been established, the OR and remote surgeons may greet each other verbally and visually. Each can see the other on their workstation screens, and speak normally as if in a face-to-face conversation. A brief discussion may take place about the surgical plan or specific details of the case. Once surgery begins, the OR surgeon may use the microscope normally, repositioning it and viewing the surgical site through it.

Handoff of control to the remote surgeon is designed to be unobtrusive and positive. That is, both sites know that control has been handed off, and no undesirable or unsafe motions ensue. The handoff is initiated verbally by the remote surgeon. That is, he simply asks for control, and the OR surgeon may agree or disagree to the handoff. If it is agreeable to the OR surgeon, a member of the OR team must press and hold a dead-man switch (a switch that must be continuously held in order to complete the circuit) in the "ON" position for the duration of the remote control. The remote surgeon is verbally informed that he/she may take control of the system which is completed by toggling a switch on remote workstation screen. At any time, control may be taken back by the OR simply by releasing the dead-man switch. A dead-man switch was chosen over a toggle switch for use in the OR to reinforce the issue of the responsibility and control of the patient's safety during the remote operation remains with the local OR team.

The IRNS provides the remote surgeon with the ability to perform gross robot motion, fine robot motion, microscope control, image retrieval, and image capture and annotation facilities. The remote surgeon has three methods of controlling the remote robot: image plane translation, image guided motion (using preoperative MRI/CT images registered to the patient), or analogical motion using a force reflecting input device. The surgeon may generate either gross or fine motions using the force reflecting input device.

Session shutdown is performed after verbal agreement by both parties. The remote surgeon then toggles a control on his workstation indicating that the connection is to be broken. Alternatively, the OR team can release the dead-man switch. On both the remote and OR workstation console, a message is displayed indicating that the remote surgeon is no longer in control, but OR operation is not affected. Shutdown in the OR is performed by exiting the IRNS software and shutting down the microscope in the normal fashion.

Communications Design

Asynchronous Transfer Mode (ATM) networking is an emerging communications technology in which fixed-length "cells" of data are transferred at speeds of over 2.3 Gbits/sec[5]. ATM supports different but *guaranteed* quality-of-service (QoS) levels depending on traffic types, and functions similarly over local and wide area networks. ATM cells can be switched through inter-exchange carrier networks and carried over earth satellite links, making it ideal for remote delivery of critical teleoperation applications. The primary advantage of ATM is that it was specifically designed for simultaneous data, voice and video transmission - precisely the characteristics required for telemedicine.

We have implemented a private ATM network for carrying digital as well as audio/video data. The network is composed of three Newbridge Networks 36150 ATM switches, two four port switches and one eight port model. All connections both between the switches and to the network end points are 150Mbit/sec OC3. The long haul connection between the remote workstation and the hospital is made using single mode fiber. All other ATM devices are physically connected using multi-mode fiber. Three high performance UNIX workstations are attached to this network, two in the lab and one in the hospital OR. Each workstation includes

video and audio sources and monitors. These are connected to the ATM switches via coaxial cables, where they are digitized using JPEG ATM video compression boards. This system is used to transport a combination of live video, audio and digital control data between the various endpoints of the network. See Figure 3.

For transmission of image data and control/feedback information, both locally and remotely, we use TelRIP[6], a general purpose data exchange system. TelRIP uses a data-centered approach to modularity, meaning that programs communicate with one another by specifying the types of data they wish to send or receive. We have developed a standardized set of TelRIP data objects that are used to transmit generic information, such as microscope settings, positions, and localizer positions. By using TelRIP, the IRNS has been developed as a set of discrete peer

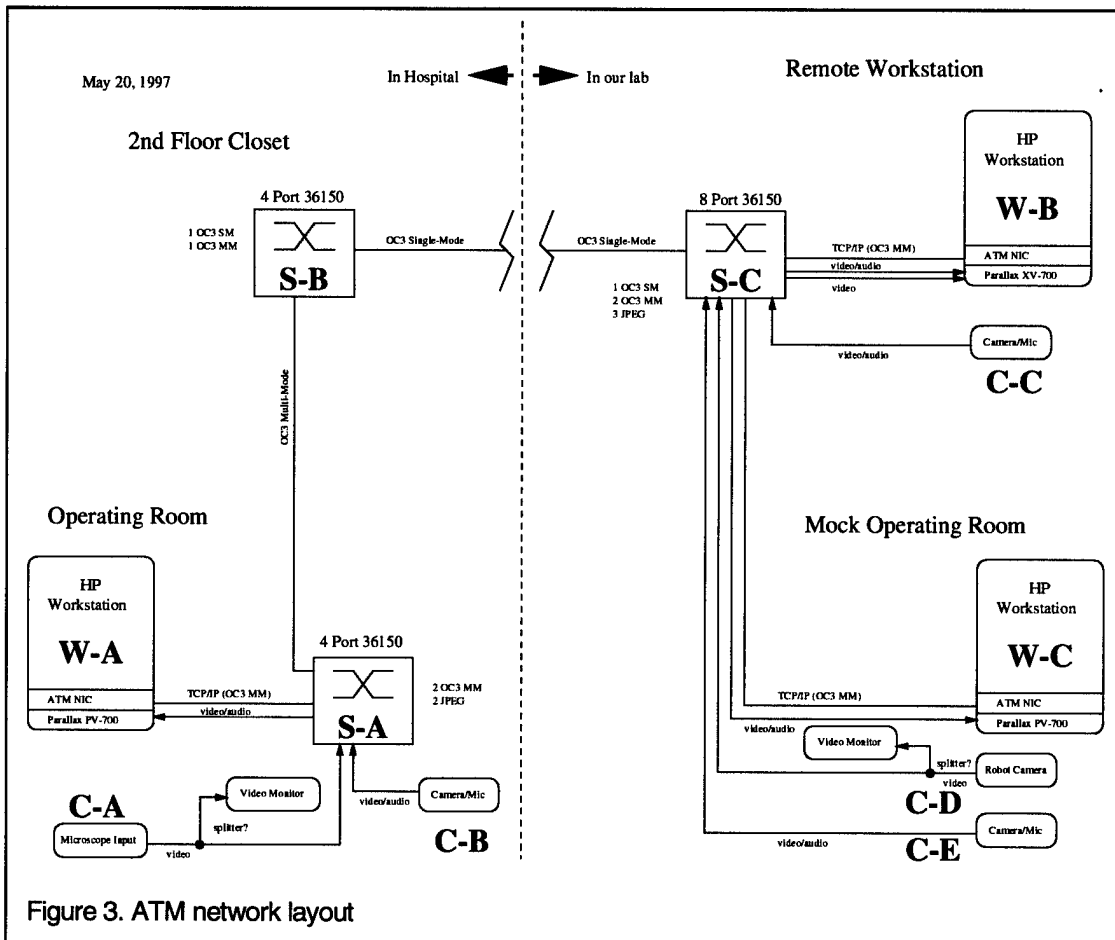

applications that run largely asynchronously. An advantage is that our processes can continue to run without knowing the state of other processes on the network. This approach also allows us to standardize the interfaces to devices and controls without predetermining the exact implementation of each interface.

In the last year all of the OC3 ATM links have been completed. All imaging, video, audio, and control data is past between the remote and OR sites using ATM links.

OR Worksite

The OR worksite consists of:

- A surgical stereo microscope mounted on a robotic transport,
- One or more 'bird's eye' view cameras on pan/tilt heads,
- An optical registration system, and
- A workstation to display and annotate pre-surgical and inter-operative medical imagery.

Live video from both the stereo microscope and the OR view camera(s) is routed through JPEG compression hardware before transmission across the ATM link and is subsequently decompressed, again in hardware, at the remote location. The OR bird's eye view cameras are included to give the remote surgeon feedback on the situation in the OR.

By sensing optical targets placed on the robot and the patient's head holder, the optical registration system precisely monitors the robot's position relative to the patient and dynamically provides a transform from the end of the robot to the patient. The registration system is also used to establish a transform between the patient in the OR and the presurgically acquired images of the patient. This spatial transform is calculated by first digitizing fiducial markers on the patient with the optical registration system's pointing device. The markers show as bright spots in the MRI images acquired before the start of the telementoring session. The locations of the markers on the patient and those in the images are input into a point-matching algorithm that then provides the transform. These two transforms give the IRNS the capability to move the microscope based on a position selected by the remote physician on the presurgical images. For example, the mentoring surgeon can indicate a surgical target and the entry point into the skull using 3D images and the microscope will be moved and aligned along that trajectory.

In our OR mockup, optical registration is performed using an Image Guided Technologies' Flashpoint 5000 [7]. The Flashpoint consists of three cameras in a rigid frame and several dynamic reference frames (DRF's) containing infrared light-emitting diodes (LED's). The DRF's are rigidly attached to the patient head frame and to the robot. By measuring the spatial relationships of the LED's on the DRF's from the three cameras, the Flashpoint determines the position and orientation of the patient DRF with respect to the robot DRF. Once this relationship is known, a point-to-point registration of fiducials is performed to calculate the exact transformation from the image base to the patient. The registration is performed using a probe instrumented in the same manner as the DRF's. As the user indicates a series of fiducials on the patient, the Flashpoint returns the position of the fiducial with respect to the patient DRF. As each point is located, the user indicates the same fiducial in the image database. Once this process is complete, the system automatically calculates the relationship between the robot base frame, patient, and image base.

In the OR, the MKM uses a built-in optical registration. The microscope is guided to focus on each fiducial in turn, and the corresponding fiducial is indicated in the MR or CT images. After all fiducials have been manually located using the procedure described above, the system calculates the transform between the robot base frame, patient, and image base.

The OR workstation can display views from the stereo microscope, pre-surgical MR and CT images, and 3D surgical planning images. Whiteboarding (described below in the User Interface section) is supported, allowing the OR team and remote surgeon to communicate by drawing on the video images. Users in the OR can interactively slice through patient data, magnify images, and view a rendered volume of the brain using thumbwheel-style widgets beneath the windows. In addition, verbal communication between the OR and the remote site is provided through microphones and ATM-linked audio.

Remote Worksite

The remote worksite consists of a graphics workstation providing:

- Microscope control,
- Robotic transport control,
- Video from the microscope and OR view cameras,
- Whiteboarding,
- Image (snapshot) archiving and annotation (using graphics and audio),
- Voice recognition commands,
- Force-reflecting handcontroller with MKM handgrip,
- Presurgical image display, including a calculated oblique slice orthogonal to the view axis,
- Three-dimensional segmented brain model display, and
- Surgical planning facilities.

Microscope controls that are extended to the remote workstation include manual focus and zoom adjustments as well as the automatic focusing control. These controls can be activated by

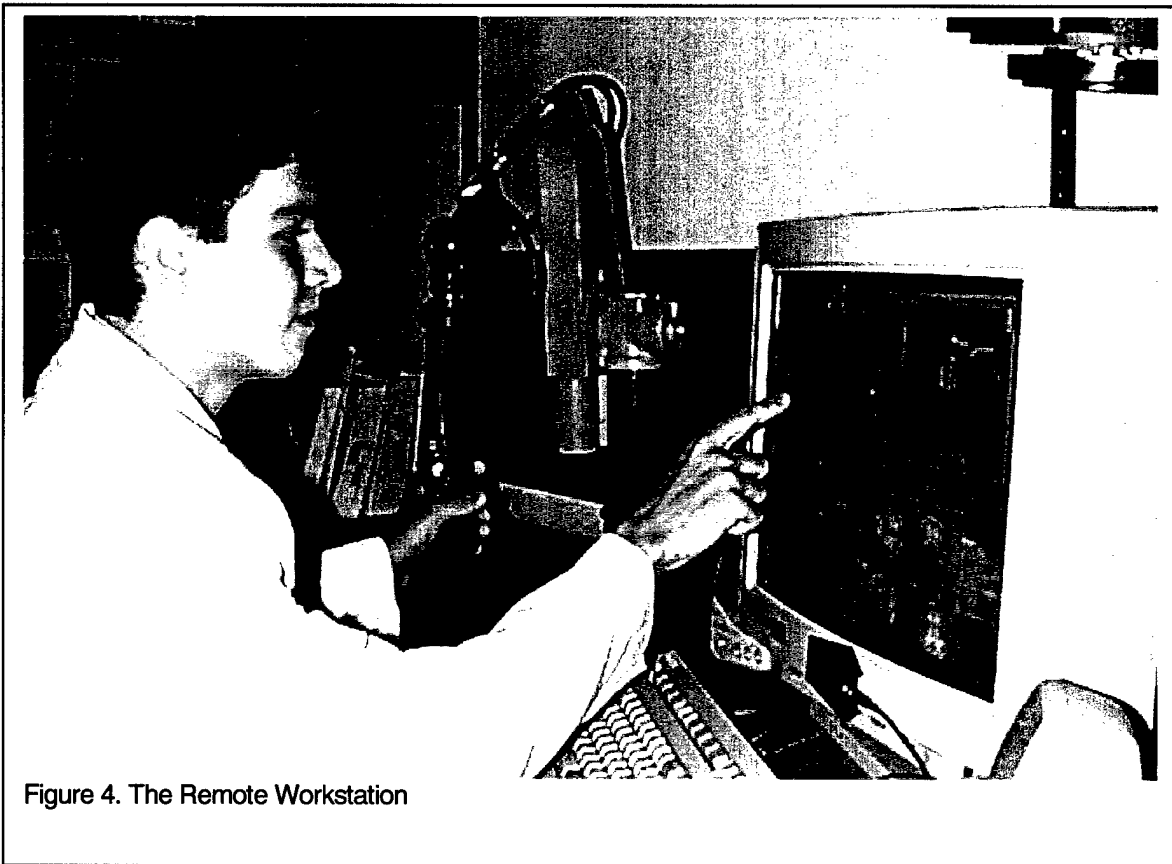

Figure 4. The Remote Workstation

using verbal commands to the system's speech recognition software, Speech Systems Phonetic Engine 500[8] or by pressing the appropriate controls on the handgrip. See Figure 4.

Microscope transport positioning control can be performed in three ways:

- Graphically - The surgeon can manipulate the graphical user (GUI) to position the microscope.

- Verbally - The surgeon can issue commands to the microscope by speaking.
- Analogically - The surgeon can use a force-reflecting handcontroller to position the microscope.

Facilities on the layout of the GUI allow the surgeon to control the position of the microscope in image space or in relation to the patient. In the former case, the surgeon may translate the microscope and zoom using arrow buttons on the edges of the video window. In this mode, the orientation of the microscope remains constant, and motion is performed as relative translations in the "tool frame" of the robot. The control buttons can be activated either by using the mouse or by pressing the touchscreen.

In addition, speech recognition software allows the remote surgeon to control panning and zooming of the microscope simply by speaking "pan left", "zoom in", etc. Most of the GUI functions now have verbal equivalents, such as panning the microscope and taking snapshots of the current microscope view. To issue voice commands, the surgeon presses a foot switch and speaks normally. The remote workstation includes a microphone attached to the face of the monitor, but a headset may be used in noisy environments. The system is speaker independent. Response has been positive from our primary consulting surgeon and casual visitors to our lab; this technique of interaction is continually being enhanced to include more commands.

To position the microscope relative to the patient, the surgeon indicates a target point (center of interest) on the three-dimensional segmented brain display, and an "entry point". The entry point is a point situated along the view axis of the microscope. Where the entry point is located on the axis is unimportant; the point is used simply to calculate a unit vector for calculation of the microscope orientation. The final position of the microscope is calculated by multiplying the unit vector by a fixed view distance. The view distance is currently a system parameter set to 600mm; however, we intend to make the view distance variable based on surgeon preference.

Analogical motion of the microscope is accomplished using a tabletop robot (Puma 260) with a MKM handgrip attached. The MKM handgrip provides force and moment readings at 20 Hz as the surgeon pushes, pulls, and twists the device. These readings are fed into a Pentium-based personal computer in which a real-time control loop moves the Puma to minimize the forces and moments. Thus, the system remains in equilibrium when the surgeon is not holding the handgrip; when the surgeon applies forces to the handgrip, the robot moves to return the force value to zero. The relative motion is scaled and applied to the OR robot as a position control command. By changing the force control equations, we can approximate dynamic effects such as inertia.

Because the force control system uses the MKM handgrip, with which the surgeon may already be familiar, and emulates a free floating body, training time is minimized. However, we continue to fine-tune parameters in the force controller to improve the control stability, avoid singularities in the robot kinematics, and limit joint and cartesian velocities. The low sample rate of the MKM handgrip causes problems for smooth motion and stability. Force control applications are more typically servoed at 1KHz. We have experimented with a JR3 force/moment sensor positioned between the robot and handgrip. This sensor provides data at 1KHz. It gave better results than the MKM sensor, but it adds weight and length to the overall handgrip. Another difficulty with the force control system is the high friction present in the Puma. This is a highly nonlinear effect that cannot be reasonably modeled. We have adopted the usual approach to friction by increasing control gains, which is adversely affecting system stability.

For added safety, we have implemented a force reflection component in the Puma controller. Arbitrary geometric volumes may be designed and issued to the real-time controller, which will restrict the Puma's motion to remain within the volume. For example, a conical volume may be specified, with the apex located at the center of interest on the patient, and the axis coincident with the view vector. This volume will restrict the microscope to remain within a reasonable radius of the original view vector. As the surgeon pushes the handgrip toward the (invisible) edge of the volume, he will feel no resistance until the boundary is encountered. At the boundary, an opposing force is automatically generated, keeping the handgrip within the volume. The effect is quite natural, and it is possible to 'explore' the volume and determine its basic shape without a-priori knowledge. We intend to improve the volume design features so that the volume may be automatically generated based on the robot and patient positions, and to display the volume dynamically in Telegrip.

Prior to the force control system, we have also experimented with "props"[9] real-world objects with magnetic trackers embedded within. There are two props: one that represents the microscope (a stylus) and one that represents the patient's head (a doll's head). By monitoring the orientation of these trackers, the system can give the actual microscope the same orientation with respect to the patient. This interface technique has been in use at our lab for some time (on a prototype surgical planning tool), and has received enthusiastic support from both surgeons and residents for its ease of use. In this application, it was not as successful due to the difficulty in performing fine motions and restricting dangerous or impossible robot motion commands.

Feedback from the OR is provided in the form of video, audio, and data. A graphical display of the microscope's current view vector is shown, to give the surgeon a better feel for the spatial configuration of the patient, microscope, and transport. The remote surgeon is presented with live (30fps) video from the microscope and the O/R room camera views. Controls on the window allow the surgeon to pan the OR room camera in 4 directions as well as zoom.

We have also implemented a "point-click" camera control interface[10]. This technique allows the surgeon to simply point at an object of interest in the room view and the camera automatically centers that object in the view. The surgeon may also indicate a rectangular region (a "zoom box") in the view and the system will pan and zoom to align the edges of the visible image with the edges of the indicated region. These techniques require careful calibration of the pan/zoom characteristics of the camera.

Snapshots of the view through the microscope can be taken and saved along with the positioning information necessary to return the transport to the snapshot view. This allows the remote surgeon to make comparisons over the course of a procedure, to document the procedure as it occurs, or to use the snapshots as a visual aid during consultations with the OR team. To return the microscope to the position from which snapshots were taken, commands may be issued via the graphical user interface or by verbal command. A separate window normally displays the most recent snapshot, but a history menu of thumbnail images lets the user select an older snapshot to display. Whiteboarding is supported over all snapshots. When a snapshot is taken at either site, the other site receives a copy so that whiteboarding remains in synchronization.

The surgical planning, image viewing, and audio facilities are identical to those on the O/R workstation. Figures 5 and 6 show screen views of the remote workstation.

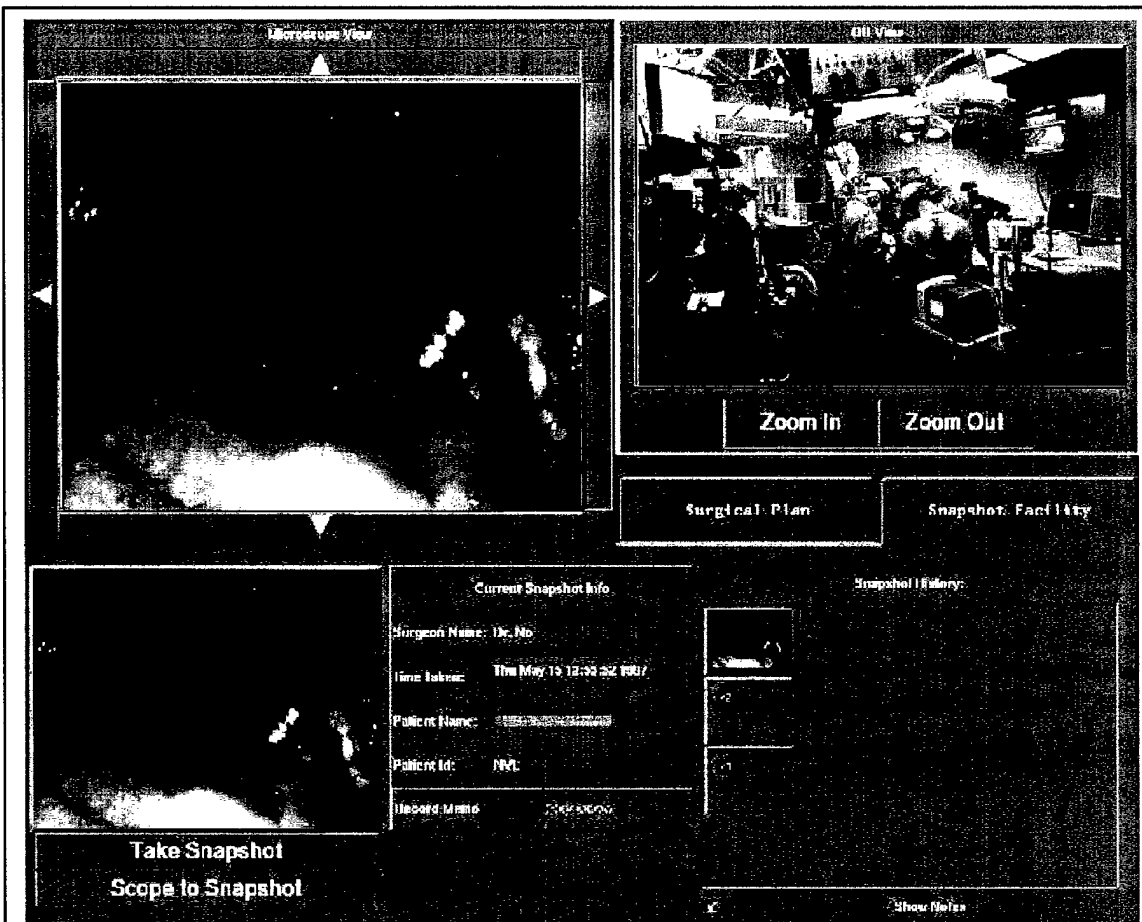

Figures 5 & 6. Screenshot of the remote workstation showing the snapshot capability (above) presurgical imagery and planning information (below).

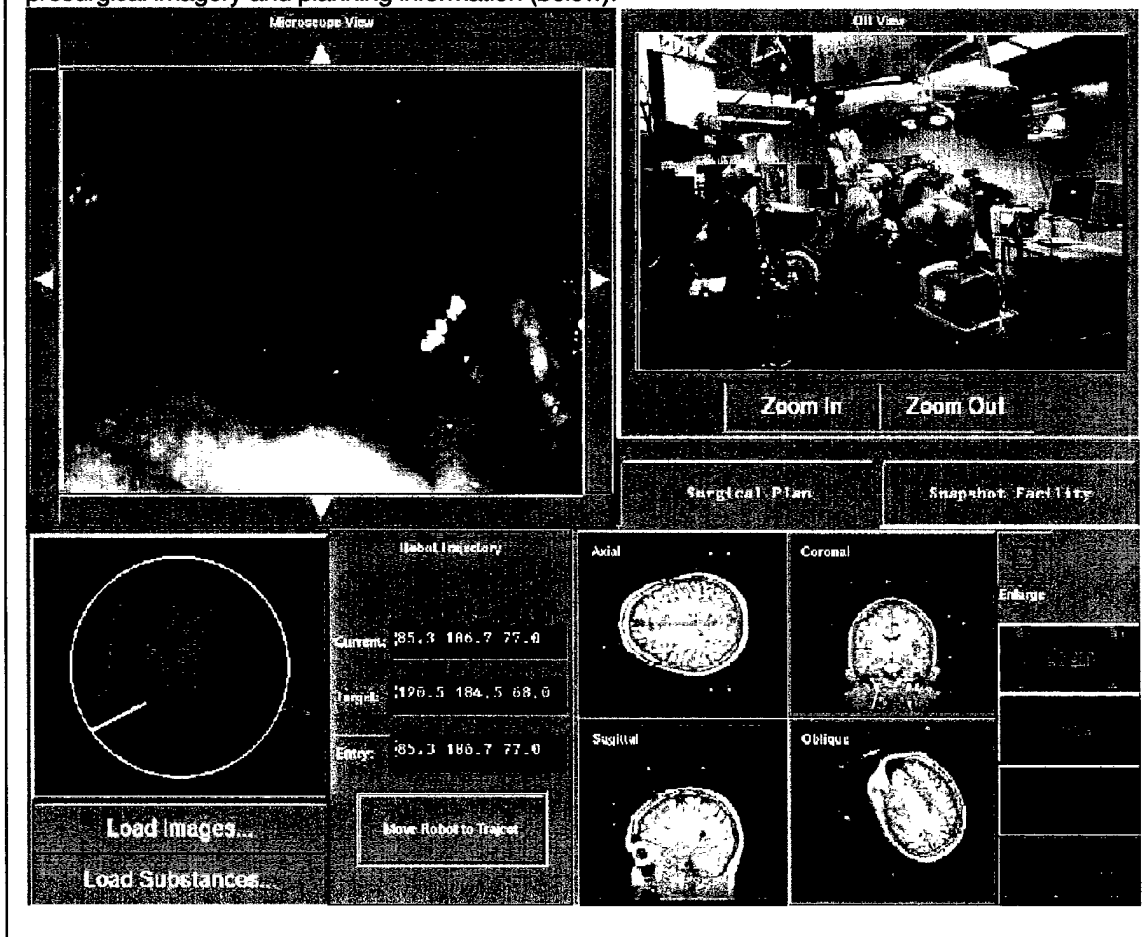

Task Analysis

Feedback from surgeons and residents has been sought throughout the development of the IRNS. Observations of surgeons using robotic microscopes have been conducted at the University of Virginia hospital, and have also been reviewed on video logs. These observations are critical in determining the current deficiencies in the usability of the surgical microscope as well as the interaction style to which the surgeons have become accustomed. Our system can correct some of the observed problems (operating table movement, jerky motion of the microscope) because of the increased flexibility afforded by its remote interface and registration system. Interviews were also conducted to determine what major functions surgeons desire. Features which came out of this process include speech recognition capabilities, a simulated view of the microscope (through Telegrip), the oblique slice view, the surgical planner interface and the snapshot facility.

In addition to the design criteria specified by the task, current research concepts from the areas of robotic control paradigms and human-computer interaction were included in the design. The selection of input devices and the graphical user interface layout and interaction style were influenced in part by previous research[11, 12].

In the area of robot control, we are working to exploit control strategies that are adaptive to time-varying delays and guarantee the control performance. As a result of the lessons learned in this research project, our work in teleoperation continues with the goal to develop a generalized approach to bilateral controlled teleoperators over an ATM network. We are concentrating on source traffic characterization in ATM networks and the design of bilateral control laws in presence of the time-varying delay. The work includes the bandwidth scheduling, the estimation of end-to-end transfer delay bound, and statistic analysis of the delay pattern. We discuss this analysis beginning below.

Robot Simulation

Models of the RR1607 and the MKM have been developed in Telegrip so that the actions of the robot could be simulated when it was not actually available. The MKM simulation includes a closed-form inverse kinematics module linked into Telegrip through a shared library. The closed-form solution is more rapid than the iterative one and, more importantly, is capable of determining the singular positions within the workspace of the microscope transport. The RR1607 model is controlled using either the built-in Telegrip iterative inverse kinematics solution or a solution we have developed. It is not possible to derive a closed form solution for the RR1607 because of the redundancy in its seven degree-of-freedom design. However, it was necessary to develop our own solution so it could be installed in the OR mockup. The simulation models can be manipulated locally through the Telegrip UI and remotely through any TCP/IP link. Various other components of the O/R have also been modeled in this simulation including the camera, optical tracker and patient.

Issues in Bilateral Control of Teleoperator over ATM Networks

This section describes in more detail our work on developing advanced control techniques over ATM networks. The work was critical to the development of the IRNS, since it is the basis of our analogical control system (the Puma desktop robot). However, the work is applicable to any teleoperator system built on ATM and in this context, it continues. Teleoperators are often master-slave systems. The operator, watching a visual representation of the worksite, performs a task by moving the master as if it were performing the task. The time-varying position control

inputs of the master are sent to the remote site as time-varying position control inputs for the slave. The slave therefore executes a scaled copy of the master's motion. When the slave contacts the environment, position error signals and contact force information are generated. These are fed back to the master and are used to backdrive its links, giving a sense of contact with the remote task. Properties of the ATM link determine how successful this sense of contact really is.

The task performance is improved by providing the contact force information to the master. When the measured contact force between the slave and the environment is fed back to the motors of the master, the contact force is said to be "reflected", and the teleoperator is said to be controlled bilaterally[13]. The block diagram of Figure 7 represents a bilateral controlled system. The operator commands a velocity forward, through the master, communication block, and slave, to the environment. Likewise, the force sensed at the environment is transmitted back through these blocks, to the human operator.

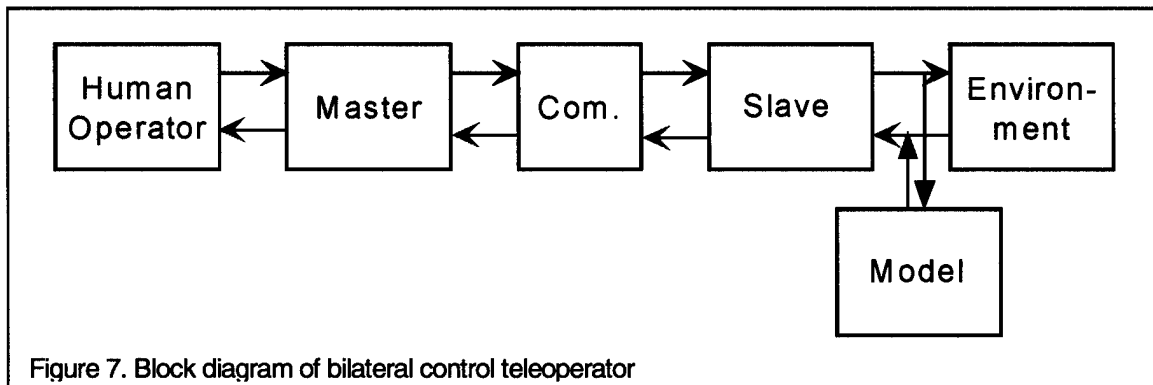

Figure 7. Block diagram of bilateral control teleoperator

The research on bilateral control over ATM networks is significant in two ways. First, the bilateral control with time-varying delay remains an open problem; second, ATM switching is an emerging communications technology that is well suited to the problem of remote operations. The primary advantage of ATM is that it was specifically designed for simultaneous data, voice and video transmission: precisely the characteristics required for the teleoperation in general. No work on bilateral control over ATM has been published in the robotics field.

Our study concentrates on two aspects. First is source traffic characterization in ATM networks, including characterization of source traffic, estimation of end-to-end transfer delay bound, and statistic analysis of the delay pattern. Second is design of the adaptive bilateral control law, which includes an adaptive bilateral control law dealing with the unknown but fixed latency, and an adaptive control law dealing with time-varying latency with known pattern. The stability of the bilateral controlled teleoperator will be proved as well.

Discussion and Conclusions

Over the last year, the project, as it was originally conceived, has been completed. There are several points related to the project's current status and the status of remote robotic surgery that warrant comment.

The characterization of teleoperation parameters on ATM networks will be an important effort for not only this project, but future teleoperation work in general. We have one Ph.D. student

who will continue her dissertation project in this area after the completion of the project. She and other members of the project have already published several papers on the subject and presented them at national meetings in the field of telerobotics.

Safety issues are crucial in a human/robotic system such as the IRNS. While we have done one preliminary study on the relevant safety issues and a study on the fault tolerant capabilities of the system, we have not yet incorporated sufficient safety precautions in the IRNS. Still of top priority in this region of the project is the development of a facile method for defining operating regions of the scope before the remote surgeon is given control and while that control is retained remotely. Currently, it is not possible to automatically determine the safe operating boundaries of the scope in a dynamic manner. With relative ease, the system can determine operating boundaries relative to the patient, given the optical-tracking of the sensors placed on the patient. However, there is the additional concern for other elements present in the OR. It is critical to have this feature as the positions of OR equipment and personnel are continually changing and the safe operating boundaries must reflect this in real time. For each object or person to be tracked is clearly unreasonable and prohibitively costly. Future advances in the area of 3D scene reconstruction from a limited number of views may offer an acceptable alternative. Such advances, however, are distant and certainly remote when considering the real-time requirement of the reconstruction.

In the last year of this project, the team has concentrated on two aspects of the system beyond the completion of the initial requirements. The first of these is reducing the size of the remote worksite. In the working remote site, there are at a minimum of three computers as well as a robot controller, and the small robot hand-controller. At the time of the project's inception, the Intel-based PC platform was incapable of the graphics performance necessary for the surgical planning aspects of the project. At the same time, the UNIX workstations were (and continue to be) lacking solutions and options in the arenas of voice recognition, live video, and real-time control. Robotics controllers on a PC card were also unavailable. As a result of a mixture of PCs and Unix workstations together with a dedicated controller for the robot were necessary to accomplish the goals of the IRNS project. Recent advancements in PC architecture, especially in graphics performance, and the migration of robotics control systems from workstations have indicated that future efforts on the project should be directed towards the development of a single PC workstation for the remote site. Clearly, this PC would be far-from-the-average PC but it is still conceivable that a modern multiprocessor PC can perform all the functions of the IRNS remote worksite. This direction has lead us to begin porting our imaging and surgical planning software to the PC platform and several of the project team have been working in this direction.

Improvements to the IRNS GUI will be greatly facilitated by the transition to the PC platform. Video systems available on PCs enable the underlying whiteboarding system of the IRNS to overlay graphics onto our video streams. This opens the possibility for more complex enhancements such as overlaying of segmented images and augmented reality elements [14].

The second aspect that we have we concentrated on is the development of an improved handcontroller for the remote workstation. As will be discussed later, the primary acceptance inhibitor of robotic systems in the surgical arena has been the "feel" of the control. We have worked to improve the haptics of the Puma-based hand-controller. The best solution involved two modes of motion; one for fine motion and one for gross motions. Within each of these modes, the haptics of the hand-controller are acceptable. However, the mechanical design of the Puma limits the available options for a smooth transition between these modes. Current force feedback positioning systems that are commercially available lack the number of degrees of freedom necessary for positioning a surgical microscope in the manner to which the surgeons are accustomed. To address this issue, we are reinvestigating the use of tracked "props" with

force feedback for scope positioning. To pursue this end, the P.I. has also secured a grant from the industrial sector.

Perhaps the most distressing component of the project has been the lack of acceptance of robotics in the surgical field. When introduced in 1994, microscopes with robotic transports were thought to be the future of the precision surgery. However, this prediction remains unfulfilled. The manufacturers of these systems have yet to produce a robotic microscope with the ease of positioning afforded by the current standard of counter-balanced scopes. Additionally, the robotic scopes together with their necessary image-navigation systems have proven very time consuming to setup and this has only contributed to their lack of acceptance. The future of robotic surgical microscopes thus remains unclear. This outlook, in turn, indicates a dim future for remote microsurgical mentoring. Still, the research within this project has contributed to the body of knowledge of force-feedback control of robotic surgical devices and the research within this lab will be continuing to address these issues.

References

- [1] Carl Zeiss Inc., (914) 681-7300.
- [2] W. Buxton, "Telepresence: Integrating shared task and person spaces," in *Proceedings of Graphics Interface '92*, 1992.
- [3] Deneb Robotics Inc., (810) 377-6900.
- [4] Newbridge Networks Corporation, (613) 591-3600.
- [5] Newbridge Networks Corporation, *ATM and SONET: The Guide to Emerging Broadband Technologies*: (613) 591-3600, 1995.
- [6] J. D. Wise and L. Ciscou, "TelRIP distributed applications environment operating manual," Rice University, Houston, TX, Tech. Rep. 9103, 1992.
- [7] Image Guided Technologies Inc., (303) 447-0248.
- [8] Speech Systems Inc., (303) 938-1110.
- [9] K. Hinckley, R. Pausch, J. Gobel, and N. Kassell, "Passive real-world interface props for neurosurgical visualization," in *ACM CHI94 Conf. Human Factors in Computing Systems*, 1994, pp. 452-458.
- [10] K. Yamaashi, J. Cooperstock, T. Narine, and W. Buxton, "Beating the limitations of camera-monitor mediated telepresence with extra eyes," in *Proc. ACM CHI'96 Conference on Human Factors in Computing Systems*, 1996, pp. 50-57.
- [11] S. Zhai and P. Milgram, "A telerobotic virtual control system," in *Proc. SPIE Cooperative Intelligent Robotics in Space II*, vol. 1612, 1991.
- [12] S. Schenker, E. D. Barlow, C. D. Boswell, H. Das, S. Lee, T. R. Ohm, E. D. Paljug, and G. Rodriguez, "Development of a telemanipulator for dexterity enhanced microsurgery," in *Proceedings of Medical Robotics and Computer-Assisted Surgery '95*, 1995.
- [13] R. J. Anderson and M. W. Spong, "Bilateral Control of Teleoperators with Time Delay," *IEEE Trans. Automatic Control*, vol. 34, pp. 494-501, 1989.
- [14] P. Milgram, A. Rastogi, and J. J. Grodski, "Telerobotic control using augmented reality," in *Proceedings 4th IEEE International Workshop on Robot and Human Communication*, 1995.

Personnel

Name	Title
J. Hunter Downs III, Ph.D.	Principal Investigator
Sean Graves, Ph.D.	Senior Project Engineer
Eugene Sullivan	Telemedicine Engineer
Dr. Neal Kassell, M.D.	Primary Consulting Physician
David Schlesinger, Ph.D.	Project Engineer
Joe Tullio	Project Engineer
Minyan Shi	Ph.D. Student (Robotics)
Ken Hinckley	Ph.D. Student (User Interface)
Delia McGarry	Masters Student (Registration)
Adrian Filipi-Martin	Systems Administrator
Garth Wermter	MKM Support
Ben Aylor	Student Contract Programmer
Ryan Gates	Student Contract Programmer

Publications

- Downs III JH, Graves BS, Shi M, Tullio JC, Aylor BF, Gates RG, Kassell NF: IRNS: A system for telerobotic surgical mentoring. IEEE Symposium on Computer-Based Medical Systems. June 1998
- Shi M, Tao G, Downs III JH: Positive Realness and Tracking of Teleoperation Systems. IEEE Conference on Decision and Control, 1998, (accepted 7/98)
- Shi M, Downs III JH, Tao G, Graves S: Control Issues in Teleoperations with Communication Time Delays. Conference on Information Sciences & Systems Proceedings, 1998.
- Shi M, Graves BS, Downs III JH: Integrated Remote Neurosurgical System. Conference on Information Sciences and Systems, 1997
- McGarry DP, Jackson TR, Plantec MB, Kassell NF, Downs III JH: Registration of Functional Magnetic Resonance Imagery Using Mutual Information. SPIE Medical Imaging Proceedings, 1997.
- Schlesinger DJ, Snell JW, Mansfield LE, Brookeman JR, Downs III JH, Ortega JM, Kassell NF: Segmentation of Cortical Surface and Interior Brain Structure Using Active Surface/Active Volume Templates. SPIE Medical Imaging Proceedings, 1997.
- Kassell NF, Downs III JH, Graves BS: Telepresence in Neurosurgery: The Integrated Remote Neurosurgical System. Medicine Meets Virtual Reality 5, San Diego, CA, Jan. 1997.
- Hinckley K, Pausch R, Downs III JH, Profitt D, Kassell NF: The Props-Based Interface for Neurosurgical Visualization. Medicine Meets Virtual Reality 5, 1997.
- Graves BS, Tullio J, Shi M, Downs III JH: An Integrated Remote Neurosurgical System. Medical Robotics/Computer Assisted Surgery, Grenoble France, Proc. 1997.
- Moore DH, Snell JW, Downs III JH: Applications of Mobile Code to Telemedicine Systems. Medicine Meets Virtual Reality 5, San Diego, CA, Jan. 1997.