

23 April 1998

**ADVANCED DISTRIBUTED  
SIMULATION TECHNOLOGY II  
(ADST II)**

**AFTER ACTION REPORT  
CDRL AB04**

**FOR**

**ARMY EXPERIMENT 4**

**DO # 0034**



19981229 015

FOR: NAWCTSD/STRICOM  
12350 Research Parkway  
Orlando, FL 32826-3224  
N61339-96-D-0002  
**DI-MISC-80711**

BY: Lockheed Martin Corporation  
Lockheed Martin Information Systems  
ADST II  
P.O. Box 780217  
Orlando, FL 32878-0217

**REPORT DOCUMENTATION PAGE**Form Approved  
OMB No. 074-0188

Public reporting burden for this collection of information is estimated to average 1 hour per response, including the time for reviewing instructions, searching existing data sources, gathering and maintaining the data needed, and completing and reviewing this collection of information. Send comments regarding this burden estimate or any other aspect of this collection of information, including suggestions for reducing this burden to Washington Headquarters Services, Directorate for Information Operations and Reports, 1215 Jefferson Davis Highway, Suite 1204, Arlington, VA 22202-4302, and to the Office of Management and Budget, Paperwork Reduction Project (0704-0188), Washington, DC 20503

1. AGENCY USE ONLY (Leave blank)		2. REPORT DATE 23 Apr 1998	3. REPORT TYPE AND DATES COVERED After Action Report	
4. TITLE AND SUBTITLE Advanced Distributed Simulation Technology II (ADST II) After Action Report CDRL AB04 for army experiment 4			5. FUNDING NUMBERS N61339-96-D-0002	
6. AUTHOR(S)				
7. PERFORMING ORGANIZATION NAME(S) AND ADDRESS(ES) Lockheed Martin Corporation Lockheed Martin Information Systems ADST II P.O. Box 780217 Orlando, FL 32878-0217			8. PERFORMING ORGANIZATION REPORT NUMBER ADST-II-CDRL-ae4-9800036A	
9. SPONSORING / MONITORING AGENCY NAME(S) AND ADDRESS(ES) NAWCTSD/STRICOM 12350 Research Parkway Orlando, FL 32826-3324			10. SPONSORING / MONITORING AGENCY REPORT NUMBER	
11. SUPPLEMENTARY NOTES				
12a. DISTRIBUTION / AVAILABILITY STATEMENT A - Approved for public release; Distribution unlimited			12b. DISTRIBUTION CODE	
13. ABSTRACT (Maximum 200 Words) Army Experiment 4 (AE4) project was conducted by the Commanding General of the U.S. Army's Training and Doctrine Command (CG, U.S. Army TRADOC) during Fiscal Year 1997 (FY97). AE4 consisted of a series of experiments followed by a presentation at the Association of the United States Army (AUSA) convention in Washington D.C. 13-5 October, 1997. These were executed in an unclassified mode. The AE4 demonstrated a proof of concept for providing a seamless linkage between the simulations and the actual Command, Control, Communications, Computers, and Intelligence (C4I) systems that will be a part of Army XXI. The AE4 demonstrated "two way" C4I communications from division level down to the individual soldier level, and featured some advancement in automated capabilities. The primary schedule of events for support of the AE4 is provided in Appendix A of this document.				
14. SUBJECT TERMS ADST-II, STRICOM, Simulation, AE4			15. NUMBER OF PAGES	
			16. PRICE CODE	
17. SECURITY CLASSIFICATION OF REPORT Unclassified	18. SECURITY CLASSIFICATION OF THIS PAGE Unclassified	19. SECURITY CLASSIFICATION OF ABSTRACT Unclassified	20. LIMITATION OF ABSTRACT UL	

NSN 7540-01-280-5500

Standard Form 298 (Rev. 2-89)  
Prescribed by ANSI Std. Z39-18  
298-102



# TABLE OF CONTENTS

<b>1.</b>	<b>AE4 OVERVIEW .....</b>	<b>1</b>
1.1	AE4 Background.....	1
1.2	AE4 Execution.....	1
1.3	Participating Organizations.....	3
1.4	Problem Definition.....	4
1.5	Objectives and Hypothesis .....	5
1.6	AE4 Residuals .....	5
1.7	Purpose and Organization of this Report.....	5
<b>2.</b>	<b>AE4 EXPERIMENTS .....</b>	<b>6</b>
2.1	Overview of AE4 Experiments .....	6
2.2	Experiment Architecture.....	7
2.3	CBS Experiment .....	8
2.3.1	Objectives .....	8
2.3.2	Component Descriptions.....	8
2.3.3	Summary Observations and Findings by Experiment Objective .....	10
2.3.3.1	Objective 1 - Establish SSM Benchmark for Subsequent Interface Assessments.....	10
2.3.3.1.1	Observations.....	10
2.3.3.1.2	Conclusions .....	11
2.3.3.2	Objective 2 - Develop and Document CBS Experiment Process.....	11
2.3.3.2.1	Observations.....	11
2.3.3.2.2	Conclusions .....	11
2.3.3.3	Objective 3 - Assess MRCI Capability .....	11
2.3.3.3.1	Observations.....	11
2.3.3.3.2	Conclusions .....	12
2.3.3.4	Objective 4 - Assess RTM Capability .....	12
2.3.3.4.1	Observations.....	12
2.3.3.4.2	Conclusions .....	12
2.3.3.5	Objective 5 - Assess LAN and WAN Communication Architecture .....	13
2.3.3.5.1	Observations.....	13
2.3.3.5.2	Conclusions .....	13
2.3.3.6	Objective 6 - Capture Experiment Results for the AUSA Presentation .....	13
2.3.3.6.1	Observations.....	13
2.3.3.6.2	Conclusions .....	14
2.3.3.7	Objective 7 - Document and Publish Experiment Results and Lessons Learned.....	14
2.3.3.7.1	Observations.....	14
2.3.3.7.2	Conclusions .....	14
2.3.3.8	Objective 8 - Provide Feedback for Future Experiments .....	15
2.3.3.8.1	Observation.....	15
2.3.3.8.2	Conclusion .....	15

2.3.4	Residuals .....	15
<b>2.4</b>	<b>CLCGF Experiment .....</b>	<b>15</b>
2.4.1	Objectives .....	15
2.4.2	Component Descriptions.....	16
2.4.3	Observations and Findings by Experiment Objective.....	18
2.4.3.1	Objective 2 - Assess the following simulation/interface systems: .....	18
2.4.3.1.1	Observations.....	19
2.4.3.1.2	Conclusions .....	20
2.4.3.2	Objective 2 - Assess the Defense Simulation Internet (DSI) .....	20
2.4.3.2.1	Observations.....	20
2.4.3.2.2	Conclusions .....	22
2.4.3.3	Observation - Long Haul Connection .....	23
2.4.3.3.1	Conclusions .....	23
2.4.3.4	Objective 3 - (CPSAA) Data Capture for AUSA .....	23
2.4.3.4.1	Observations.....	23
2.4.3.4.2	Conclusions .....	23
2.4.3.5	Objective 4 - Document Experimental results and lessons learned.....	24
2.4.3.5.1	Observations.....	24
2.4.3.5.2	Conclusions .....	24
2.4.4	Additional Observations and Findings.....	24
2.4.4.1	Observation 1 .....	24
2.4.4.1.1	Conclusions .....	25
2.4.4.2	Observation 2 - TSIU "perceived truth" rather than "ground truth".....	25
2.4.4.2.1	Conclusion 26 .....	26
2.4.4.3	Observation 3 - TSIU 2-way information flow (SIM/C4I).....	27
2.4.4.3.1	Conclusion 27 .....	27
2.4.4.4	Observation 4 - MSAC Casualty Generator.....	27
2.4.4.4.1	Conclusion 27 .....	27
2.4.4.5	Observation 5 - MSAC integrated to MCS .....	28
2.4.4.5.1	Conclusion 28 .....	28
2.4.4.6	Observation - MSAC mounted on ATCCS 2.0.....	28
2.4.4.6.1	Conclusions .....	28
2.4.4.7	Observation - Vehicle Health Monitoring System (VHMS).....	29
2.4.4.7.1	Conclusions .....	29
2.4.4.8	Observation - VHMS simulation-based training.....	29
2.4.4.8.1	Conclusions .....	30
2.4.4.9	Observation - VHMS to populate Appliqué.....	30
2.4.4.9.1	Conclusions .....	30
2.4.4.10	Observation - MMAI interaction HLA & DIS federations .....	31
2.4.5	Conclusions.....	31
2.4.6	Recommendations.....	31
2.4.7	Observation - MMAI Communications Effects Server (CES).....	32
2.4.7.1.1	Conclusions .....	32
2.4.7.2	Observation - MMAI free text orders Appliqué to ModSAF.....	32
2.4.7.2.1	Conclusions .....	32
2.4.7.3	Observation - ModSAF 3.0 Eagle/SIU.....	33
2.4.7.3.1	Conclusions .....	34
2.4.7.4	Observation - Eagle/SIU supporting unit deaggregation to entity level.....	34
2.4.7.4.1	Conclusions .....	34
2.4.7.5	Observation - CPSAA presentation.....	35
2.4.7.5.1	Conclusions .....	35
2.4.8	Residuals .....	35
<b>2.5</b>	<b>DBBL Experiment .....</b>	<b>35</b>

2.5.1	Objectives .....	36
2.5.2	Component Descriptions.....	36
2.5.3	Observation 1 – LWS to Appliqué.....	37
2.5.3.1	Conclusions .....	37
2.5.3.2	Observation 2 - DI SAF .....	37
2.5.3.3	Conclusions .....	38
2.5.3.4	Observation 3 – Data Logger .....	38
2.5.3.5	Conclusions .....	38
2.5.3.6	Observation 4 .....	38
2.5.3.7	Conclusions .....	39
2.5.4	Residuals .....	39
<b>3.</b>	<b>AE4 PRESENTATION .....</b>	<b>39</b>
3.1	Overview.....	39
3.2	Reception Area.....	41
3.3	Introduction Theater Area.....	41
3.4	Command Post Situational Awareness Area (CPSAA).....	41
3.5	Demonstration Execution.....	42
3.5.1	Hotel and Union Labor .....	42
3.5.2	AE4 Teardown Pack and Ship .....	42
3.5.2.1	HVAC .....	42
3.5.3	Power .....	42
3.5.3.1	Telephone/DataFax .....	43
3.5.4	Exhibit Support.....	43
3.5.4.1	Perimeter Drapes.....	43
3.5.4.2	Furniture .....	43
3.5.4.3	Introduction Theater.....	44
3.5.4.4	Carpet .....	44
3.5.5	Audio Video Support .....	44
3.6	Lessons Learned.....	45
3.7	Conclusions and Recommendations .....	45
<b>4.</b>	<b>AE4 PLANNING AND MANAGEMENT .....</b>	<b>46</b>
4.1	Program Organization .....	46
4.2	Reporting.....	48
4.2.1	Contractor Progress, Status, and Management Report.....	48
4.2.2	Contractor Cost/Schedule Status Report.....	48
4.2.3	4.3.3 Program Management Reviews .....	48
4.2.4	Scheduling .....	48
4.3	In Progress Reviews (IPR) .....	48
<b>5.</b>	<b>POINTS OF CONTACT.....</b>	<b>48</b>

**APPENDIX A – MASTER SCHEDULE..... 1**

**APPENDIX B - SCENARIO DOCUMENTATION..... 1**

**APPENDIX C - DATA COLLECTION SHEETS..... 1**

CBS Experiment..... 1

CLCGF Experiment..... 20

DBBL Experiment..... 33

**APPENDIX D - AE4 COMPONENT ARCHITECTURE DIAGRAMS ..... 1**

**APPENDIX E - AE4 NETWORK ARCHITECTURE DIAGRAMS ..... 1**

**APPENDIX F – CLCGF COMPARISON MATRIX ..... 1**

**APPENDIX G - AE4 RESIDUAL PRODUCTS..... 1**

Products with Tangible Benefit..... 1

Products with Intangible Benefit ..... 5

**APPENDIX H - POINTS OF CONTACT (POC’S)..... 1**

**APPENDIX I - RESIDUAL GFP/GFE..... 1**

Government Furnished Equipment..... 1

Government Furnished Property ..... 1

**APPENDIX J - ORGANIZATION STRUCTURE ..... 1**

**APPENDIX K - GLOSSARY ..... 1**

**TABLE OF FIGURES**

Figure 1.2-1 AE4 architecture diagram for CBS, CLCGF, and DBBL experiments ..... 3

Figure 2.1-1—AE4 experiment organization..... 7

Figure 2.5.2-1 CBS Communications Architecture..... 10

Figure 2.6.3.2.2-1 Long Haul Network..... 22

Table 2.8.5-1 DBBL Experiment Residuals ..... 39

Figure 3.2-1 AE4 Presentation Facility Layout and Traffic Flow ..... 40

Figure 3.5.3.1-1 AE4 Telephone Distribution ..... 43  
Figure 3.5.3.1-3 AE4 2-Way Radio Assignment..... 43  
Figure 3.5.5-1 Introduction Theater AV Network Layout..... 44  
Figure 3.5.5-2 CPSAA AV Network Layout..... 45  
Figure 4.1-1 AE4 Organization..... 46

23 April 1998

## Keywords:

Army Experiment 4 (AE4); Army Battle Command Systems (ABCS); Command, Control, Communications, Computers, and Intelligence (C4I); Modular Reconfigurable C4I Interface (MRCI); Run Time Manager (RTM); Tactical Simulation Interface Unit (TSIU); Appliqué Interface; Medical Situational Awareness and Control (MSAC); Vehicle Health Monitoring System (VHMS).

## 1. AE4 Overview

Army Experiment 4 (AE4) project was conducted by the Commanding General of the U.S. Army's Training and Doctrine Command (CG, U.S. Army TRADOC) during Fiscal Year 1997 (FY97). AE4 consisted of a series of *experiments* followed by a *presentation* at the Association of the United States Army (AUSA) convention in Washington D.C. 13-15 October, 1997. These were executed in an unclassified mode. The AE4 demonstrated a proof of concept for providing a seamless linkage between the simulations and the actual Command, Control, Communications, Computers, and Intelligence (C4I) systems that will be a part of Army XXI. The AE4 demonstrated "two way" C4I communications from division level down to the individual soldier level, and featured some advancement in automated capabilities. The primary schedule of events for support of the AE4 is provided in Appendix A of this document.

### 1.1 AE4 Background

This paper provides a discussion on the results of the Army Experiment 4 (AE4) experiments which were executed 4 August through 5 September 1997. During the AE4 experiments, interfaces between various simulations and Army Battle Command Systems (ABCSs) were evaluated. Three separate experiments were performed to study various aspects of digitization of the battlefield: A Corps Battle Simulation (CBS) experiment, a Corps Level Computer Generated Forces (CLCGF) experiment, and a Dismounted Battlespace Battle Lab (DBBL) experiment. These experiments overlapped sufficiently to provide "two way" information flow from the division down to the individual soldier level. Discussion of the following simulation to ABCS interfaces is provided: The Run Time Manager (RTM), the Modular Reconfigurable C4I Interface (MRCI), the Tactical Simulation Interface Unit (TSIU), the Simulation Support Modules (SSMs), The Federation of Intelligence, Reconnaissance, Surveillance and Targeting, Operations, and Research Models (FIRESTORM)/High Resolution Simulation Stimulator (HRSS) simulation, the MITRE ModSAF Appliqué Interface (MMAI), and the Land Warrior System command and control interface to Appliqué. Additionally, discussion is provided on the Medical Situational Awareness and Control (MSAC) System, the Vehicle Health Monitoring System (VHMS), and Command Forces (CFOR).

### 1.2 AE4 Execution

The Army Experiment 4 (AE4) coordination, integration, and some development activities were performed under the U.S. Army Simulation, Training, and Instrumentation Command (STRICOM) Advanced Distributed Simulation Technology (ADST) II contract. Lockheed Martin Information Systems and their subcontractors performed the AE4 ADST II contract tasks.

23 April 1998

The AE4 sponsor was the U.S. Army Training and Doctrine Command (TRADOC). Other participating organizations are listed in the following section and Appendix I.

From 4 August through 5 September 1997, the AE4 team conducted a suite of experiments designed to create a working simulation that stimulated Army XXI tactical command and control (C2) systems from division level down to the platform/individual soldier levels. These experiments were broadly characterized as follows:

- Corps Battlefield Simulation (CBS) Experiment
- Corps Level Computer Generated Forces (CLCGF) Experiment
- Dismounted Battlespace Battle Lab (DBBL) Experiment

The AE4 experiment architecture is illustrated in Figure 1.2-1 on the following page. The AE4 experiment architecture was comprised of simulation systems, interface technologies, and Army Battle Command System (ABCS) components.

The AE4 experiments provided a baseline simulation and tactical interface environment, which provided valid and realistic insight into the linking of simulations with Army XXI C2 systems. These experiments were performed using a distributed simulation network (comprised of various simulations) and a separate tactical communications network (comprised of the Army Battle Command System (ABCS) version 2.0.4 (with patches) configured for each level of command). The simulation and tactical communications networks were interconnected utilizing various interfaces. These interfaces were evaluated for their potential for Warfighter training applications.

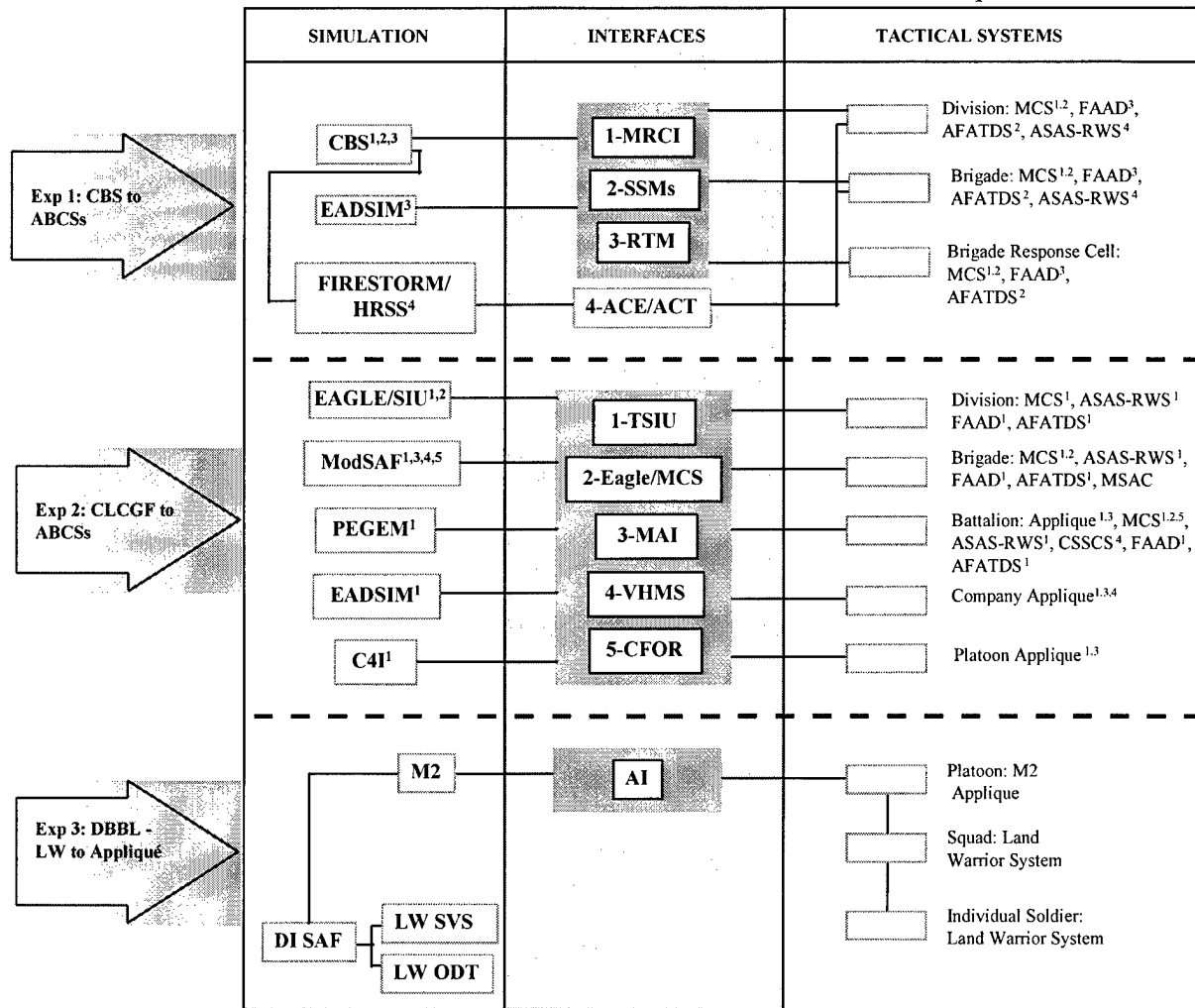

Note: The coding scheme (i.e., 1, 2, 3, etc) is used to associate the simulation drivers, the interfaces, and the tactical systems (e.g., FIRESTORM feeds the ACE/ACT which feeds the Division and Brigade level ASAS-RWSs, etc).

Figure 1.2-1 AE4 architecture diagram for CBS, CLCGF, and DBBL experiments

### 1.3 Participating Organizations

TRADOC's Battle Lab Integration, Technology and Concepts Directorate (BLITCD) was responsible for the conduct of AE4. Lockheed-Martin Corporation (LMC) served as the primary systems integrator—under the direction of the Army's Simulation, Training and Instrumentation Command (STRICOM)—as part of the Advanced Distributed Simulation Technology II (ADST II) Program. The MITRE Corporation provided technical direction and consulting services, analyzed experiment results, and wrote an AAR.

The success experienced on the AE4 program was largely due to the strong teamwork among the organizations involved. The following organizations comprised the AE4 team:

Government organizations:

23 April 1998

- 1) Army Training and Doctrine Command (TRADOC)
- 2) Army Simulation, Training, and Instrumentation Command (STRICOM)
- 3) Army Dismounted Battlespace Battle Lab (DBBL)
- 4) Army Space and Missile Defense Command (SMDC)
- 5) Army Battle Command Battle Lab (BCBL) -- Fort Huachuca
- 6) Army National Simulation Center (NSC)
- 7) Electronic Proving Ground (EPG)
- 8) Program Executive Office Command, Control, and Communications Systems (PEOC3S)
- 9) Program Manager (PM) Air Defense Command and Control System (ADCCS)
- 10) PM Intel Fusion
- 11) Army Medical Research and Materiel Command (USAMRMC)
- 12) Army Aviation and Missile Command (AMCOM) Logistics Laboratory.
- 13) Soldier Support (Ft. Benning, Ft. Hood, Ft. Huachuca, Ft Leavenworth)

Contractor organizations:

- 1) Lockheed Martin Information Systems (LMIS)
- 2) Lockheed Martin Services Group (LMSG)
- 3) TASC
- 4) Aegis Research
- 5) Science Applications International Corporation (SAIC)
- 6) Mitre Corporation
- 7) Coleman Research Corporation (CRC)
- 8) Reality By Design
- 9) Hughes Aircraft Corporation
- 10) TRW
- 11) Cubic Applications Incorporated
- 12) Mystech
- 13) McGuire-Reeder Incorporated
- 14) Image Technical Services (ITS)
- 15) Mevatec Corporation
- 16) Booz-Allen Hamilton
- 17) Ulf Helgesson Industrial Design
- 18) Exhibit Crafts Inc
- 19) Soldier support for the AE4 was supplied by 4ID, Fort Leavenworth, Fort Sill,

TRADOC Analysis Command (TRAC) in Fort Leavenworth (while currently not officially tasked) provided outstanding support to the AE4 team. This support was greatly appreciated, and significantly contributed to the successful execution of the AE4 program

**1.4 Problem Definition**

Current studies indicate that the digitized force will increase military effectiveness and readiness. The digitized force requires two-way information flow from division to the individual soldier level, providing all echelons with an integrated, consistent view of situational awareness at their respective levels of command and control. Experimentation provides insight into some of the challenges facing digitization of the force by identifying potential cost-effective solutions that

23 April 1998

leverage investments in "Information Age Technology". The AE4 Program addressed some of these issues through a suite of experiments primarily aimed at evaluating the capabilities of simulations and simulation interfaces for populating Army Battle Command Systems (ABCSs) and using the data these tactical systems provide.

### ***1.5 Objectives and Hypothesis***

The AE4 experiment objectives focused on evaluating the interfaces that allow simulation systems to communicate with C4I systems; these form the key components in linking simulation systems to C4I systems. The intent was to assess the status of such interfaces in their abilities to support collective training, especially as they contribute to the reduction of exercise staffs and the improvement of training realism. The experiment-specific objectives of AE4 were:

1. Determine the extent to which the AE4 experimental hypothesis is true.
2. Determine the extent to which the experimental objectives, identified in the CBS and CLCGF experiment plans (included in the AE4 Technical Concept Plan), are met.
3. Provide observations, conclusions, recommendations, and lessons learned concerning the performance of the experimental systems (primarily the simulation to C4I interfaces), the simulations, the C4I systems, the communications infrastructure, and the experimental process.
4. Provide a set of residual capabilities that can have an immediate impact on the Army's ability to use simulation to support collective training.

The AE4 experiment hypothesis was as follows:

*If a functional simulation/C4I architecture is developed that links constructive and virtual simulations to Army XXI C4I systems then soldiers can use it to practice Army XXI situational awareness on go-to-war Army Tactical Command and Control Systems (ATCSS).*

The rationale for this hypothesis is that simulations can provide realistic input and response to C4I systems, allowing commanders and their staffs to train in their command and control processes without incurring the expense of sending large numbers of troops into the field.

### ***1.6 AE4 Residuals***

AE4 produced a number of residual, leave-behind capabilities. These residual products can be grouped into two categories: those with the potential for immediate, tangible impact on the way the Army conducts Situational Awareness training and those that are less tangible, relating indirectly to Situational Awareness training. Both are discussed in Appendix F.

### ***1.7 Purpose and Organization of this Report***

This AE4 After Action Report focuses on both of these objectives. It documents the observations, conclusions, recommendations, and residuals derived from the AE4 experiments and AUSA demonstration. It provides a permanent record of the AE4 project and its residual products, and serves as a resource for future work.

The remainder of this report is organized as follows:

23 April 1998

- Section 2 documents the AE4 experiments and observations;
- Section 3 reports on the AE4 presentation at the 1997 AUSA Conference;
- Section 4 discusses the planning and management that went into AE4;
- Section 5 provides a list of AE4 participants and points-of-contact;
- The Appendices provide details on the master schedule, experiment and presentation scenario, test plans, data collection, architecture, hardware, presentation scripts, residuals and participating organizations.

## 2. AE4 Experiments

Linking appropriate simulation systems to the ABCSs has potential for improving the ability to develop capabilities in echelon-to-echelon command and control, mission rehearsal, course of action analysis, unit training, and doctrine development. The AE4 program's purpose was to leverage investments made in synthetic environments, ABCS components, and the simulation interface technologies that facilitate inter-communication among them.

### 2.1 Overview of AE4 Experiments

From 4 August through 5 September 1997, the AE4 team conducted a suite of experiments designed to evaluate various simulations and interfaces to ABCSs. These experiments can be broadly characterized as:

1. Corps Battlefield Simulation (CBS) Experiment
2. Corps Level Computer Generated Forces (CLCGF) Experiment
3. Dismounted Battlespace Battle Lab (DBBL) Experiment

A three to four hour division level battlefield scenario was used as the basis for the experiments. The scenario used was a modified version of a portion of the Division XXI Advanced Warfighting Experiment (DAWE) that was to be conducted in November 1997. In the scenario, summarized below, the Fourth Infantry Division (4ID) fights a conventional battle in the early years of the 21<sup>st</sup> century.

*SCENARIO: "The 4th Infantry Division executes a division attack west. 3rd Brigade is in the south executing the main attack. 2nd Brigade conducts a supporting attack in the north. 1st Brigade is the division reserve 30 to 40 kilometers behind and between the 3rd and 2nd. G2 notices enemy reinforcements being applied to the main objective area, weakening the area vicinity northern boundary. The Division Commander requests a boundary change from Corps to allow him to attack with the 1st Brigade to the north, leaving 2nd and 3rd Brigades to continue as planned. As the 1st prepares the replan, two issues must be addressed: 1) the logistics for a move north have not been planned, and the 1st must refuel before its attack and 2) there is a small village in the north area with an enemy emplacement that must be neutralized."*

The 4ID is the Army's Experimental Force (EXFOR) that has been equipped with prototypes of the Army Battlespace Command Systems (ABCS). These systems are expected to provide 4ID soldiers with enhanced situational awareness and the ability to plan and act quicker than their enemy. AE4 results provide insights on improving the ability of using simulations to stimulate

23 April 1998

C4I systems to train commanders and their staffs in the use of ABCS systems for improved situational awareness.

The AE4 experiment was composed of four phases: experimentation, data collection, data analysis, and documentation. The experiment was completed and data collected during the period 4 August through 6 September. Analysis of the data was performed in October and November, during which time the documented observations, conclusions, and recommendations appearing in this report were developed.

In the CBS experiment, two way information flow was demonstrated from the division to the battalion level. ABCS components representative of the following systems participated: WARLAB Tactical Analysis Center (TAC), Command and Control Vehicle (C2V) TAC, and the Battle Command Vehicle (BCV). In the CLCGF experiment, two way information flow was demonstrated from the division to the platoon level. ABCS components representative of the following systems participated: division TAC, C2V TAC, BCV, company level Appliqué, and platoon level Appliqué. Figure 2.1-1 below illustrates the echelon levels that were played, and the overlap of these experiments, such that complete two-way flow of information was simulated from the division to the individual soldier levels.

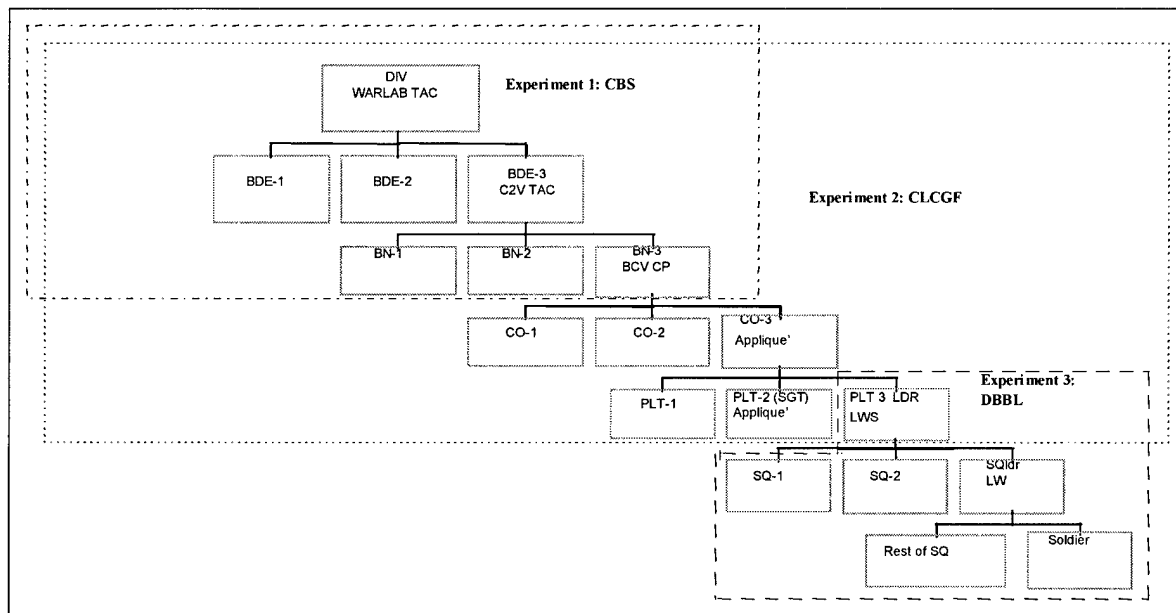

Figure 2.1-1 – AE4 experiment organization

## 2.2 Experiment Architecture

The AE4 hybrid architecture is composed of simulation systems, interface technologies, and ABCS components. The experiments were designed to exercise and evaluate the AE4 architecture components, with special focus on interface technologies that support “simulation to tactical system” linkages (see Figure 2.1-1). As part of the evaluation process, problems were documented with recommendations made for enhancements and future reuse. Each of the

23 April 1998

experiments is discussed in more detail in the following sections, with full test plans, component architectures, and data collection forms provided in the Appendices.

### **2.3 CBS Experiment**

In the CBS experiment, the common battlefield scenario was executed from division to the battalion levels on Lantica terrain. The CBS experiment was run from 4-15 August 1997. The host site for this experiment was the Electronic Proving Ground (EPG) in Fort Lewis, Washington. Other participating sites included the Battle Command Battle Lab (BCBL) in Fort Huachuca, the WARLAB in Fort Leavenworth, and the Warfighting Analysis and Integration Center (WAIC) in Rosalyn, VA.

#### **2.3.1 Objectives**

A total of eight objectives were identified for the CBS Experiment, in addition to those established for AE4 as a whole:

1. Establish SSM benchmark to assess RTM and MRCI interfaces
2. Develop and document CBS experiment process
3. Assess MRCI capability
4. Assess RTM capability
5. Assess distributed, heterogeneous communication architecture
6. Capture experiment results for the AUSA demonstration
7. Document and publish experiment results and lessons learned
8. Provide feedback for future experiments.

The components assessed in the CBS experiments are briefly described in the following section, followed by a summary of observations organized by objectives.

#### **2.3.2 Component Descriptions**

The primary simulation-to-C4I tactical system interfaces evaluated were the Run Time Manager (RTM) and the Modular Reconfigurable C4I Interface (MRCI). These are summarized below:

- RTM. The RTM was used in conjunction with a CBS air and missile defense master interface, and Extended Air Defense Simulation (EADSIM), high fidelity/entity level simulation model providing CBS with air and missile defense interactions displayed on Forward Area Air Defense (FAAD) systems.
- MRCI. The Defense Modeling and Simulation Office (DMSO) has initiated the prototype development of the MRCI. For the AE4 program, the MRCI was integrated as an interface between CBS and Maneuver Control System (MCS) components and used to update CBS ground unit locations on the MCS boxes.

The following systems also participated in the CBS experiment:

- The integrated Federation of Intelligence, Reconnaissance, Surveillance and Targeting, Operations, and Research Models (FIRESTORM)/ High Resolution Simulation Stimulator

23 April 1998

(HRSS). The FIRESTORM/HRSS system allows users to focus, direct, prioritize and interpret the output of the larger Joint Information Environment, and provides intelligence data to the All Source Analysis System (ASAS).

- Analysis Control Team (ACT). The ACT is the hub of the Direct Support Military Intelligence Company capabilities. Tethered to brigade command post, it provides the brigade with intelligence connectivity, fusion, analysis and the ability to maintain the intelligence database. For the division level, an Analysis Control Element (ACE) is utilized which behaves similarly, but on a much larger scale. A single ASAS and Common Ground Station (CGS) workstation were used to provide a "slice" of the ACE functionality for the AE4.
- Corps Battle Simulation (CBS). CBS is a man-in-the-loop simulation that supports training of a corps commander and his battle staff, major subordinate commands, and major subordinate elements of headquarters of the corps in conduct of deep operations and decisive operations.
- EADSIM. EADSIM is a workstation-hosted, system-level simulation, which is used by combat developers, materiel developers, and operational commanders to assess the effectiveness of Theater Missile Defense (TMD), and Air Defense systems against the full spectrum of extended air defense threats.
- Simulation Support Modules (SSM's). The SSM's provide an interface between CBS and components of the ABCSs, and was be used as the benchmark for evaluation of the MRCl.
- ABCS Components. Section 2.1 identifies the ABCS components that participated in the CBS experiment, and illustrates the overall CBS experiment architecture.

The "leave behind" architecture for the CBS experiment is well-suited for use in the Training Exercises and Military Operations (TEMO) domain, especially in the area of staff level training. The AE4 CBS Experiment components are discussed in more detail in Appendix X.

The CBS experiment was a long haul exercise consisting of four different sites: Ft. Leavenworth (WARLAB); Ft. Lewis (EPG); WAIC; Ft. Huachuca Battle Tech Lab. The architecture for the CBS Experiment is depicted in Figure 2.5.2-1. Communication among the distributed sites consisted of a combination of the Army Interoperability Network (AIN) and dial-up modems. The distributed nature of the experiment components, coupled with the heterogeneous communication links, placed a high premium on pre-experiment integration and configuration procedures. LMC, in coordination with PEOC3S, provided on-site assistance during the system integration and checkout activities. A combination of telephonic and on-site technical support was available during the conduct of the experiment.

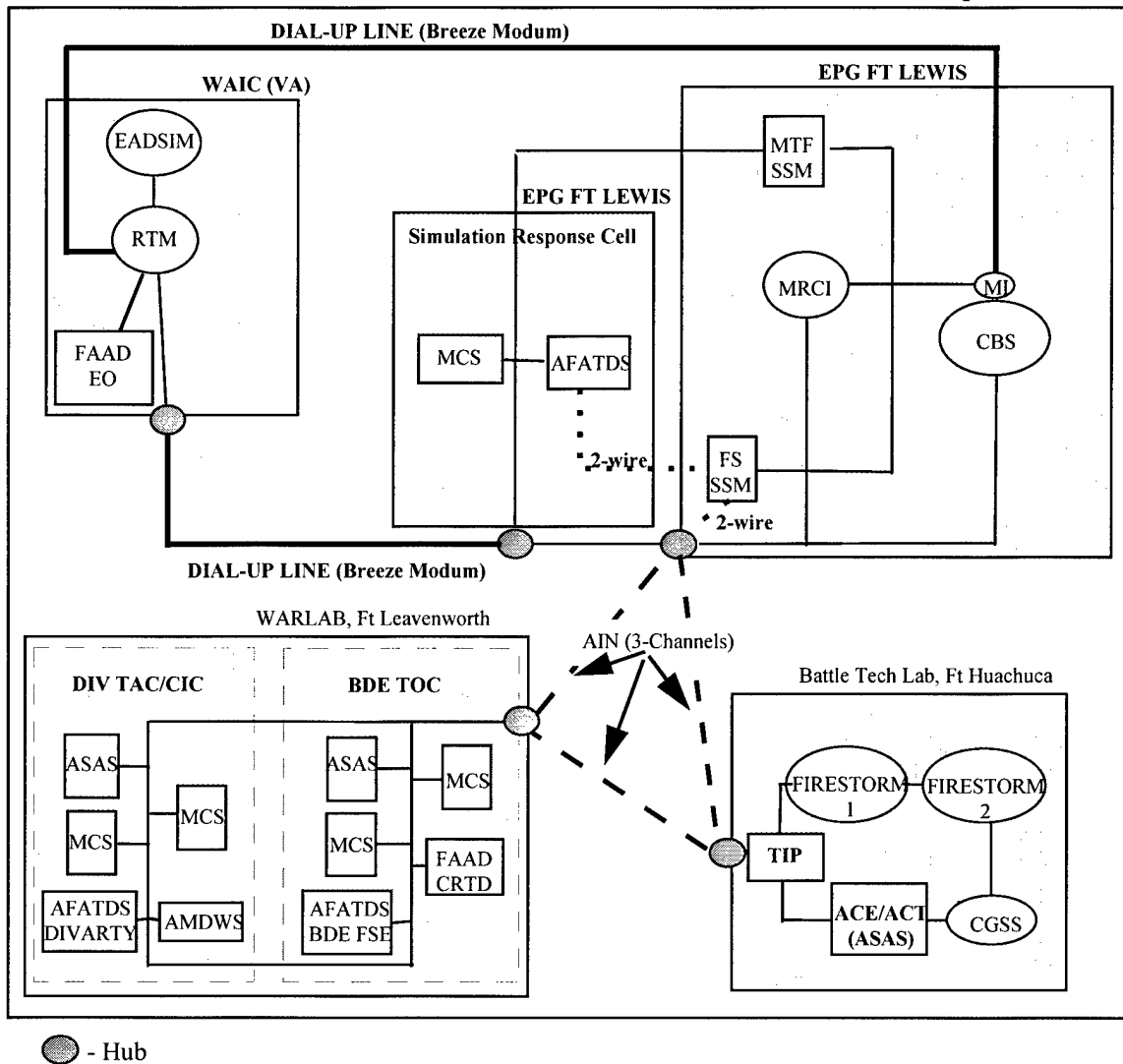

Figure 2.5.2-1 CBS Communications Architecture

**2.3.3 Summary Observations and Findings by Experiment Objective**

A total of eight objectives were identified for the CBS Experiment. It was envisioned that these objectives would support not only this experiment, but, with modification, could be used to support subsequent simulation-to-C4I system experiments within the Army. The summary observations, conclusions and recommendations relative to each experiment objective are presented below.

**2.3.3.1 Objective 1 - Establish SSM Benchmark for Subsequent Interface Assessments**

**2.3.3.1.1 Observations**

Benchmark functionality data were captured for the MTF SSM. Data captured included: friendly unit location and unit resource information; battlefield geometry; and enemy location information.

23 April 1998

The unit resource and battlefield geometry messages were received by MCS but did not auto-post to the MCS database. Manual entry by the MCS operator was required.

#### 2.3.3.1.2 Conclusions

Changes in MCS releases necessitate updating the MTF SSM to ensure messages are processed correctly and posted to the MCS database. Since the unit status is normally sent by the CSSCS SSM, this functionality for the MTF SSM had not been updated for the version of MCS being used.

The battlefield geometry message contained too many segments, which prevented MCS from processing and posting the information. It was noted by the senior MCS operators that this segment overloading happens periodically, and the procedure is to send the information piecemeal (send fewer segments in each message).

### 2.3.3.2 Objective 2 - Develop and Document CBS Experiment Process

#### 2.3.3.2.1 Observations

PEOC3S technical support was sporadic and lacked continuity during the system configuration and integration phases.

Funding for many participants was not forthcoming in a timely manner.

All data collection objectives to support analysis and report preparation were achieved.

#### 2.3.3.2.2 Conclusions

Insufficient PEOC3S technical support necessitated modifications to original plans to meet experiment objectives. End result was a less robust experiment than envisioned.

Late funding hampered the planning and execution of the experiment, which exacerbated an already compressed schedule.

Extensive data collection and analysis efforts greatly increased credibility and validity of the experiment and this report. However, tools to support automated logging and analysis of experiment data would greatly increase the effectiveness and accuracy of future experimental analysis.

### 2.3.3.3 Objective 3 - Assess MRCI Capability

#### 2.3.3.3.1 Observations

The MRCI experienced no problems interfacing with the CBS Master Interface (MI) and had no apparent intrusive effects on CBS.

The MRCI successfully extracted friendly unit location information from the CBS MI and sent the information to MCS. The information was processed and auto-posted to the MCS database at the battalion MCS located at Ft. Lewis.

23 April 1998

The friendly unit location information was not processed correctly (nor auto-posted) by either the division or brigade MCS located at Ft. Leavenworth.

The MRCI System Specific Interface (SSI) software must be loaded onto the MCS host platform.

There was a consistent round-down error in the last digit of the easting location field in each friendly unit location sent to MCS. Since the grid size was 100 meters, the MCS location reflected a 100 meter offset in easting location.

#### 2.3.3.3.2 Conclusions

The functionality of the MRCI must be expanded significantly to achieve a level of functionality comparable with that of the MTF SSM.

The modular design concept for the MRCI is questionable, e.g., the loading of interface software on ATCCS platforms is not a preferred solution.

The opinion of one MCS technician at Ft. Leavenworth (who happened to be there for another meeting) was that the problem with MRCI information not being processed correctly by MCS was due to errors in one or more configuration files. Since both MCS and MRCI rely heavily on configuration files and there were no dedicated, on-site MCS personnel, it was not possible to isolate the problem.

#### 2.3.3.4 Objective 4 - Assess RTM Capability

##### 2.3.3.4.1 Observations

The RTM experienced no problems interfacing with the CBS MI and had no apparent intrusive effects on CBS.

The RTM was successful in de-aggregating air and TBM events extracted from CBS and then handing them off to EADSIM.

The RTM successfully provided all air and TBM messages to the appropriate FAAD systems.

The RTM provided TBM early warning messages to the AMDWS (located at Ft. Leavenworth) utilizing the extended FDL message set.

The RTM was able to send TADIL-B messages to the Tactical Communications Interface Module (TCIM), but the TCIM did not successfully transmit the messages to the FAAD EO.

##### 2.3.3.4.2 Conclusions

The RTM provides increased training realism for FAAD personnel due to the representation of air and TBM events at the entity level vice the aggregated level provided by the FAADC2I SSM.

Additional resources are required to support the use of the RTM in CBS-driven staff training exercises, i.e., EADSIM and its associated support. On the plus side, the Army can conduct

23 April 1998

FAAD staff training, when desired, without Joint Training Confederation models such as the Air Warfare Simulation (AWSIM).

The design of the RTM interface to the CBS MI was effective and efficient for the volume of events contained in the experiment.

The RTM message flow to the FAAD EO system resulted in an accurate and timely low altitude air picture.

The capability of the RTM to send TADIL-B messages to the FAAD EO was not demonstrated due to the non-availability of a Digital Non-secure Voice Telephone (DNVT).

### **2.3.3.5 Objective 5 - Assess LAN and WAN Communication Architecture**

#### **2.3.3.5.1 Observations**

The operational availability of the Army Interoperability Network (AIN) was outstanding for long haul connectivity.

There was a lack of ancillary items required to fully utilize the AIN voice and commercial/ISDN dial-in capabilities.

Trouble-shooting and data collection efforts were hampered due to the lack of a dedicated, open voice channel.

The DOIM personnel at Ft. Leavenworth and Ft. Huachuca were not able to configure the networks for an ATCCS environment and PEOC3S personnel were not available to provide network configuration support in a timely manner (par. 3.3.2.2).

Differences in ATCCS network configurations between the DAWE SIMEX I and the CBS Experiment created significant problems because technical support personnel were not familiar with the concept of the CBS Experiment, and hence the configuration needed (par. 3.3.2.2).

#### **2.3.3.5.2 Conclusions**

The AIN is a cost-effective, reliable alternative to the DSI for distributed experiments of this nature.

Continuous voice connectivity between experiment control personnel and data collectors at all sites is a must for trouble-shooting and synchronizing data collection efforts in a distributed environment.

Network support personnel must be identified and provided as part of the overall support package for experiments of this nature.

### **2.3.3.6 Objective 6 - Capture Experiment Results for the AUSA Presentation**

#### **2.3.3.6.1 Observations**

23 April 1998

Screen captures, data, and lessons learned from the experiment were captured to support the AUSA Presentation.

Operators gained valuable experience that they carried forward to the remaining AE4 experiments and to the AUSA Presentation.

The AMDWS has more functionality than the FAAD CRTD.

#### 2.3.3.6.2 Conclusions

The CBS Experiment provided valuable data and lessons learned on the RTM and MRCI interfaces, which also supported the AUSA Presentation.

Residuals from the CBS Experiment that were referenced during the AUSA Presentation are documented in Appendix X.

The AMDWS enhanced the training of division air defense staff personnel.

### **2.3.3.7 Objective 7 - Document and Publish Experiment Results and Lessons Learned**

#### 2.3.3.7.1 Observations

This report documents the results and lessons learned from the CBS Experiment.

Identification of those things that did not work as well as those things that did work are equally important in terms of residual value to the Army.

In a few instances, unqualified personnel were nominated by their units to support the experiment.

Operators were not adequately briefed on the objectives and scenario, nor were they fully aware of the sequence of events for the experiment.

#### 2.3.3.7.2 Conclusions

The AE4 Reports published by BLITCD provided a good baseline data for future experiments.

The report-out philosophy for AE4 of including the failures as well as the successes help to identify areas for future improvement in interfacing C4I systems to simulation capabilities.

There is such a small pool of trained ATCCS operators within TRADOC that any requirement outside of the EXFOR is difficult to support. The problem in locating trained ATCCS operators is symptomatic of the current state of affairs in the Army - there aren't enough experienced ATCCS operators. The priority for trained ATCCS operators is the EXFOR (as it should be). However, institutionally the Army should be able to support other limited requirements for trained ATCCS operators.

23 April 1998

The lack of more operator involvement in the day-to-day discussions of the experiment must be counted as a lost opportunity. Those operators that have participated in these types of exercises or experiments can provide valuable insights and suggestions for improvement.

### **2.3.3.8 Objective 8 - Provide Feedback for Future Experiments**

#### **2.3.3.8.1 Observation**

The CBS Experiment was an opportunity for the Army M&S and training communities, as well as interface developers, to gain valuable feedback for use in future experiments and development efforts.

#### **2.3.3.8.2 Conclusion**

This report provides insights, as well as being an excellent reference document, for use in planning and conducting future simulation-to-C4I system interface experiments.

### **2.3.4 Residuals**

The "leave behind" architecture for the CBS experiment is well-suited for use in all three domains: Advanced Concepts and Requirements (ACR), Research, Development, and Acquisition (RDA), and Training Exercises and Military Operations (TEMO). It will readily accommodate test and evaluation activities, human factor studies, and other applications primarily due to features, which greatly reduce the manpower requirements for running an exercise. The CBS experiment Residuals are discussed in more detail in Appendix F.

## **2.4 CLCGF Experiment**

In the CLCGF experiment, the common battlefield scenario was executed from division to the platoon levels on Lantica terrain. The Grafenfels terrain (a subset of Lantica) supported areas of operation where units were deaggregated down to the entity level. The primary simulation to C4I tactical system interfaces evaluated include the Tactical Simulation Interface Unit (TSIU), the Mitre ModSAF Appliqué Interface (MMAI), and the Eagle-MCS Interface. In addition, advancements made in logistics' Vehicle Health Monitoring System (VHMS), Medical Situational Awareness and Control (MSAC), and automated capabilities were evaluated. In Appendix F there is a CLCGF comparison table with notes describing all the ATCCS and Applique interfaces tested.

### **2.4.1 Objectives**

The primary objectives of the CLCGF experiment were the following:

- 1) Develop and document the CLCGF experiment process
- 2) Evaluate the various simulation/interface components:
  - a) Tactical Simulation Interface Unit (TSIU)
  - b) Medical Situational Awareness and Control (MSAC)
  - c) Vehicle Health Monitoring System (VHMS)
  - d) Mitre ModSAF Appliqué Interface (MMAI)
  - e) Eagle-Maneuver Control System (MCS) Interface
  - f) Command Forces (CFOR)
- 3) Assess the ability of the upgraded Defense Simulation Internet (DSI) to support a distributed simulation exercise

23 April 1998

- 4) Capture data to support the (CPSAA) at the AE4 Presentation at the AUSA General Meeting
- 5) Document and publish the Experiment results and lessons learned

#### 2.4.2 Component Descriptions

The interfaces components and simulation systems used in the CLCGF experiment are summarized below.

- TSIU. The TSIU uses aggregated (Eagle) and deaggregated (entity level simulations) simulation data to provide simultaneous multilevel (i.e., division, brigade, battalion, company, platoon) feeds to tactical command and control systems. It provided a two way Variable Message Format (VMF) interface between command and control systems and simulations. Ongoing developments include modifications to allow VMF messages to be created from Signal Protocol Data Units (PDU's) and transmitted to Appliqué systems. These developments provided friendly force tracking, enemy force tracking (via spot reports), damage assessment, and Nuclear, Biological, and Chemical (NBC) data to Appliqué systems. The following automated features also were developed within the TSIU:

- 1) VMF "Call for Fire" messages were translated into CCSIL to be automatically executed by ModSAF.

- MMAI. The MMAI provided a two way VMF interface between Appliqué systems and simulations. The MMAI provided friendly force tracking, enemy force tracking (via spot reports), and battle damage assessments data to Appliqué systems.

- Eagle-MCS Interface. The Eagle-MCS was to provide a two way interface between the Eagle simulation and MCS. Unfortunately, the planned Eagle support necessary to execute this evaluation was not available during the test.

- MSAC. The MSAC serves as a command and control system for tactical medical operations, providing Situational Awareness (SA) data for friendly and enemy forces, and other data needed for medical operations, such as evacuation platforms, treatment facilities, and medical logistics. The MSAC used data from the simulation network to perform its functions, enabling the medical community to participate in real-time, combat simulation exercises.

- During the AE4 CLCGF experiment, the VHMS workstation combined the data received from the VHMS simulation and live VHMS module, and successfully populated the target Appliqué system with the required information. The live data was provided by a tank operating at Eglin Air Force Base. The Appliqué system performed a "roll-up" of the data received so that this could be passed on to the CSSCS. It is noted however, that the linkage between Appliqué and the CSSCS was not established due to database correlation problems. This was not a problem within the VHMS, but the target C4I systems, and is one example of the interoperability problems that can exist among ABCS systems.

- The VHMS experiment demonstrated a means by which the CSSCS can be utilized at the Battalion level (i.e. linking Appliqué to CSSCS). The use of the CSSCS at Battalion level is currently only a concept (generally, CSSCS supports the Brigade and Division levels), but may

23 April 1998

be worth consideration in the future given the logistical information that can be provided from Appliqué systems. Additional information concerning the VHMS can be found at the following web site address: <http://loglab.redstone.army.mil>

- Command Forces (CFOR). CFOR could not be evaluated to lack of SME support.

Other systems participating in the CLCGF experiment included:

- Eagle Simulation. Eagle is an aggregate level simulation designed for Corps level analytic work, but is capable of portraying any echelon in several environments. Eagle is a product of the Model Research Directorate (MRD), Training and Doctrine Command (TRADOC) Analysis Center (TRAC), Ft. Leavenworth Kansas. Eagle provides command and control functions that enable single operators to plan for and direct large numbers of aggregated entities on the simulated battlefield. Eagle models command and control (C2), maneuver, direct and indirect fires, helicopters, air defense, Close Air Support (CAS), and intelligence fusion.
- Simulation Interface Unit (SIU). The SIU is a product being developed by Science Applications International Corporation (SAIC) for TRAC Fort Leavenworth that is used to interface the Eagle Simulation with ModSAF. The SIU allows aggregated entities in Eagle to be selectively deaggregated into individual ModSAF entities. The SIU provides aggregate level simulation packets for units contained within Eagle (which is in addition to the entity level packets being provided by ModSAF). This allows Eagle units to be “ghosted” within ModSAF and for Eagle unit icons to appear on ModSAF Plan View Displays.<sup>1</sup> AE4 was the first full-scale use of the latest version of the SIU that was developed to interface with ModSAF Version 3.0. Although the SIU was a component of the simulation architecture for CLCGF and not an experimental system per se, a number of valuable insights into SIU functionality and the problems associated with combining aggregate and entity level simulations were made.
- ModSAF. Version 3.0 is the latest release of the ModSAF software. ModSAF is a United States Army Simulation Training and Instrumentation Command (STRICOM) product being developed by various contractors. ModSAF is a set of software modules and applications used to construct simulation and Computer Generated Forces (CGF) applications. ModSAF modules and applications allow a single operator to create and control large numbers of entities that are used for training, test, and evaluation. ModSAF entities, which include ground and air vehicles, dismounted infantry (DI), missiles, and dynamic structures, can interact with each other and with manned individual entity simulators to support training, combat development experiments, and test and evaluation studies.
- Post Engagement Ground Effects Model (PEGEM). PEGEM is an SMDC simulation that models NBC hazards based on post-engagement dispersal and propagation of the chemical cloud resulting from intercepting a TBM with a chemical warhead. Simulated sensors placed within the virtual environment can then detect the chemical cloud. PEGEM reports ground footprint

---

<sup>1</sup> As noted in Chapter 2, the SIU does not provide support for interactions (e.g. battles) between aggregated units and individual entities.

23 April 1998

centroids, and sensor warning messages (NBC-1), has real time event scheduling, and can independently score contaminated assets.

- The C4I Surrogate. The C4I Surrogate is an SMDC simulation that is used as a test driver to produce various types of "sensed" information from the simulation environment. It provides a low fidelity simulation source for the intelligence information feeds that would be received by the tactical C4I systems. Each simulated element has a radio and affiliated frequency that each model emulates when sending DIS Transmitter and Signal PDU's. The sensor models are unclassified and are written in Ada and C. The C4I surrogate runs on a Sun SPARC workstation utilizing the Solaris 2.5.1 operating system. It supports DIS protocol version 2.0.4, connects to the DIS network via Ethernet, and uses the UDP/IP protocol.
- EADSIM. EADSIM is a workstation hosted, entity based simulation developed for the U.S. Army Space and Missile Defense Command (SMDC) which allows users to assess the effectiveness of Theater Missile Defense (TMD), and Air Defense systems against the full spectrum of air and missile defense threats. It was originally developed as an analytic tool, and has a significant number of analysis aids and displays, as well as a robust post-processing report generation capability. Simulation models include the following: fixed and rotary wing aircraft, Theater Ballistic Missiles (TBM), cruise missiles, sensors (IR and radar), intelligence collection, satellites, C2 structures, sensor and communications jammers, communications networks and devices, and fire support. EADSIM can also represent a variety of ground support equipment (e.g. launchers, trucks, etc.) and generic noncombatants. EADSIM provides a many-on-many theater-level simulation of air and missile warfare, an integrated analysis tool to support joint and combined force operations, and a tool to augment maneuver force exercises at all echelons with realistic air defense training. Operational commanders, trainers, and analysts to model the performance, and predict the effectiveness of ballistic missiles, surface-to-air missiles, aircraft, and cruise missiles in a variety of user-developed scenarios use EADSIM.
- ABCS Components. Figure 2.1-1 above (middle section) identifies the ABCS components that participated in the CLCGF experiment and the overall CLCGF experiment architecture.

### **2.4.3 Observations and Findings by Experiment Objective**

A total of five objectives were identified for the CLCGF Experiment. It was envisioned that these objectives would support not only this experiment, but, with modification, could be used to support subsequent simulation-to-C4I system experiments within the Army. The summary observations, conclusions and recommendations relative to each experiment objective are presented below.

#### **2.4.3.1 Objective 2 - Assess the following simulation/interface systems:**

- Tactical Simulation Interface Unit (TSIU)
- Medical Situational Awareness and Control (MSAC)
- Vehicle Health Monitoring System (VHMS)
- MITRE ModSAF-Appliqué Interface (MMAI)

23 April 1998

- Eagle - MCS Interface
- Command Forces (CFOR)

#### 2.4.3.1.1 Observations

- The **TSIU** was assessed in its ability to utilize aggregated (Eagle) and deaggregated (entity level simulations) simulation data to provide simultaneous multi-level (i.e., division, brigade, battalion, company, and platoon) feeds to tactical systems, and in providing a two way Variable Message Format (VMF) interface between Appliqué' systems and simulations. The TSIU performed all tasks as intended.
- The **MSAC** was assessed in its ability to provide realistic training opportunities for medical support personnel. The MSAC serves as a command and control system for tactical medical operations, providing total Situational Awareness for friendly and enemy forces/objects such that Medical commanders and their staffs are challenged to make "real time" battlefield decisions with respect to route planning considerations, selection of available evacuation platforms and treatment facilities, and in providing medical logistics. A casualty generator is utilized to provide notification regarding casualties. As casualties are incurred, the medical support team executes their mission taking into account the data received by the MSAC system. In the CLCGF Experiment the MSAC performed all tasks as intended although full MSAC functionality was not integrated into the 2.0.4 version of MCS and the MCS Beta version was used as a surrogate. Details of the assessment of the MSAC are at paragraphs 4.3.1.4 through 4.3.1.6.
- The **VHMS** represented a concept for providing Situational Awareness for maintenance personnel for both training and real-world operations. The VHMS consists of two major components: a VHMS Module mounted on a live military vehicle, and the VHMS Workstation that is used to receive live data from the VHMS Module, model the function of the VHMS for simulated entities, and transmit the digital logistics data received to Appliqué and CSSCS systems. In the CLCGF Experiment VHMS was able to provide maintenance data from both live and simulated vehicles. Details of the assessment of the VHMS are at paragraphs 4.3.1.7 through 4.3.1.9.
- The **MMAI** provided a two way VMF interface between Appliqué' systems and the ModSAF simulation. The MMAI was actually a federation of simulations and interfaces based on the High Level Architecture (HLA). The MMAI development effort demonstrated the potential of the HLA to provide a framework for integrating C4I systems with simulations. The baseline capability was extended by introducing realistic communications effects. Assessment of the MMAI was limited due to resource constraints. However, the MMAI did demonstrate, among other things, an approach to provide a realistic simulation of communications effects for Situational Awareness training.

23 April 1998

- The **Eagle-MCS interface** is being developed under the joint sponsorship of TRAC (Fort Leavenworth) and Battle Command Battle Lab (Fort Leavenworth). Eagle-MCS is a two way interface between Eagle and MCS which can be used to pass operations orders from MCS systems to simulated Eagle units for execution, and populate MCS systems with simulation data generated by Eagle. Attempts were made to perform the integration of the Eagle-MCS interface into AE4 CLCGF experiment, however, it was determined that the Eagle-MCS interface (which was developed for version 7.0 of the MCS system) could not be integrated with MCS version 6.3 (the version being used to support the AE4 experiments). Thus, it was decided not to run the Eagle-MCS portion of the experiment.
- **CFOR** is a Research and Development effort being performed for the Synthetic Theater Of War (STOW) 97 program. This effort is being sponsored by the Defense Advanced Research Projects Agency (DARPA). The CFOR Command Element (CE) modules interface with ModSAF Version 3.0 directly via CCSIL. The purpose of CFOR is to model the command and control activities of the company-level unit commanders. Unfortunately, due to resource constraints it was not possible to get the CFOR CEs integrated into the CLCGF architecture. Therefore no assessment of CFOR was performed in AE4.

#### 2.4.3.1.2 Conclusions

The simulation systems and interfaces examined in the CLCGF Experiment demonstrated a number of capabilities that have the potential to improve the Army's current ability to use simulations to support training in the use of Situational Awareness. For example, whereas current training simulations focus primarily on the intelligence and operations staff, simulation systems such as MSAC and VHMS augment current by enabling participation by the medical and logistical communities. Interfaces such as TSIU, MMAI, Eagle-MCS, and CFOR demonstrate approaches for: providing two-way flow of information between simulations and C4I systems, stimulating C4I systems with perceived truth instead of ground truth, and reducing the size of the support staff needed to run a training exercise. The SIU demonstrated an approach for combining aggregate and entity-level simulations into a single simulation federation.

#### 2.4.3.2 Objective 2 - Assess the Defense Simulation Internet (DSI)

##### 2.4.3.2.1 Observations

In previous AE's the DSI had not performed as well as other WANs such as the Interim Defense Research and Engineering Network (IDREN) that was experimented with in AE3. Problems with the DSI had included poor reliability, limited bandwidth, and difficulties scheduling DSI access.<sup>2</sup> However, in FY97 the DSI was scheduled to undergo a major upgrade to include new high speed routers and incorporation of an industry standard data protocol. Since it was desired to demonstrate a capability to incorporate live, virtual and constructive simulations in the

---

<sup>2</sup> Problems encountered with the DSI are documented in the AE3 After Action Report.

23 April 1998

CLCGF federation<sup>3</sup> it was decided to use the M2 virtual simulator at the Dismounted Battlespace Battle Lab (DBBL) to represent virtual simulation and to link this simulator to the federation via the DSI. A DSI connection between the DBBL and STRICOM, using the upgraded system, was combined with a dedicated fiber optic line between STRICOM and the CLCGF test facility at the ADST II Operational Simulation Facility (OSF). In addition, it was planned to use the DSI to link the simulations running at the Advanced Research Center (ARC) in Huntsville (EADSIM, PEGEM, and C4I Surrogate) into the DIS federation at the OSF.

---

<sup>3</sup> “Live” simulation involves the participation of live soldiers and real world equipment. A field training exercise is an example of live simulation. In the CLCGF Experiment, live simulation was represented by the live M1A1 tank linked to the VHMS simulation “Virtual” simulation means live soldiers using simulated equipment. Simulators such as SIMNET or CCTT are examples of virtual simulation. “Constructive” simulation means that everything is simulated - there are no live players, although there may be operators or controllers. Eagle, ModSAF and the other CLCGF simulations are examples of constructive simulation.

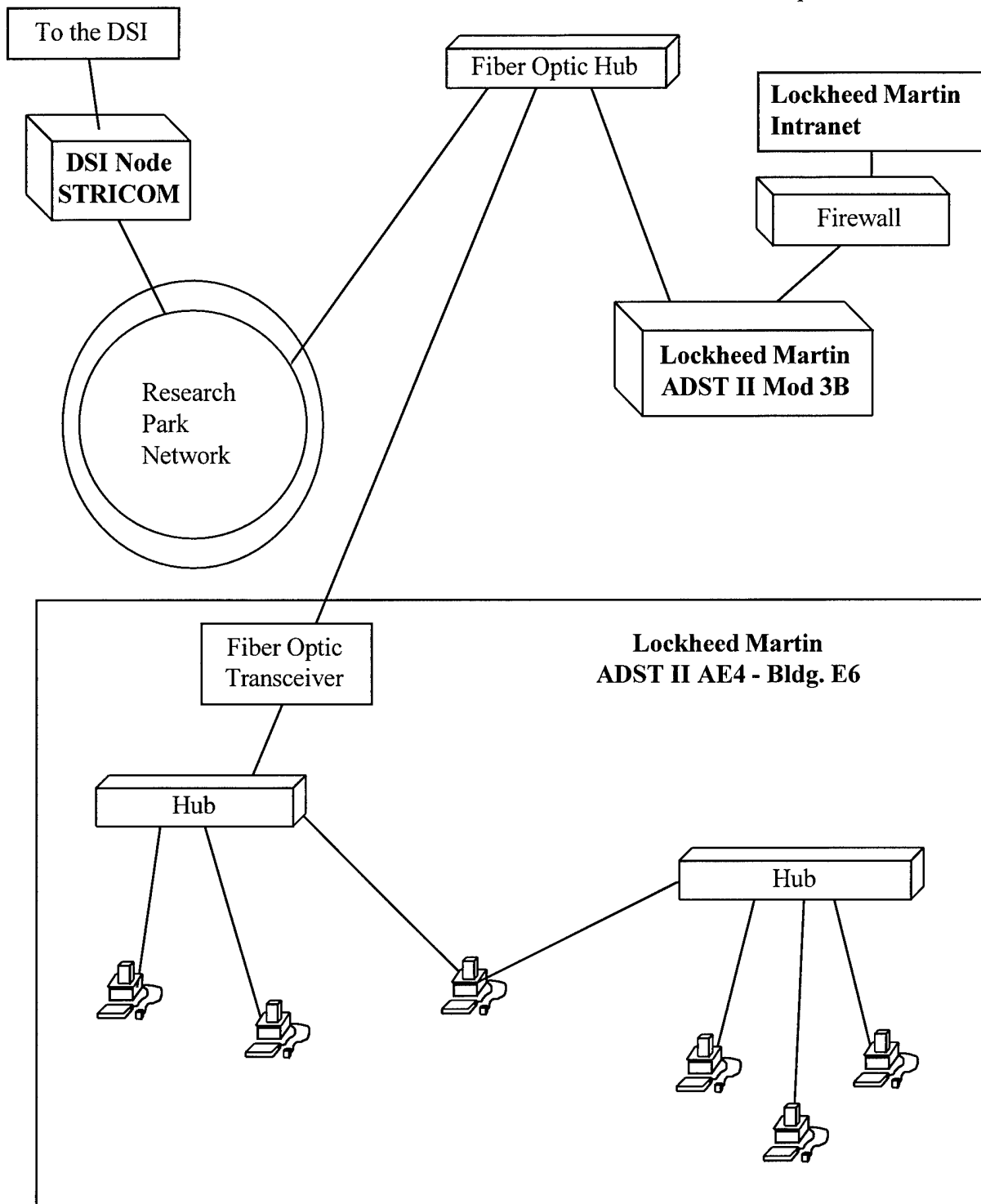

Figure 2.6.3.2.2-1 Long Haul Network

2.4.3.2.2 Conclusions

The DSI has tremendous potential for supporting distributed simulation experiments and exercises. The Defense Information Systems Agency (DISA), the agency responsible for the DSI,

23 April 1998

should evaluate the AE4 observations regarding the DSI to determine if they provide information that could be used to improve DSI performance.

#### **2.4.3.3 Observation - Long Haul Connection**

As discussed in paragraph 2.6.3.2 the connection between the DBBL, the ARC and the OSF was a combination of the upgraded DSI and a dedicated fiber optic line. The connection between the DSI and the fiber optic line was the Research Park Network (in Orlando), which includes as members both Lockheed Martin Information Systems, where the OSF is located, and STRICOM, which has a node on the DSI. When it was learned that it was not possible to exchange simulation data between the DBBL or the ARC and the OSF and exhaustive effort was undertaken to find the fault. Houston Associates supported this effort, the government's contractor responsible for administration and maintenance of the DSI. Although a number of problems were found and resolved during system integration and test, a connection was never successfully established prior to the start of the experiment period. At this point the personnel responsible for the ARC connection chose to replace the DSI with a Breeze Modem link. Further analysis determined that traffic was passing from the DBBL to STRICOM and from the OSF to STRICOM but was not crossing the bridge between the DSI and the leased line. Despite the best efforts of a number of network technicians, including a technician from Houston Associates, this problem was not resolved until the last day of the experiment. As a result, although the DBBL M2 virtual simulator was integrated into the CLCGF Experiment as planned, there was not sufficient time to collect data on the performance of the DSI or its impact on the overall experiment.

##### **2.4.3.3.1 Conclusions**

Since the DSI connection between the DBBL and OSF was not established until the last day of the experiment, it is not possible to draw any conclusions about DSI performance. However, it is a cause for concern that this connection failed despite extensive planning and the best efforts of a number of skilled technicians over a week's time. If the potential of the DSI is to be realized, it must be made more reliable and "user friendly". Through the debugging efforts at the OSF and STRICOM it was determined that the subnets were established incorrectly by Houston Associates, Inc.

#### **2.4.3.4 Objective 3 - (CPSAA) Data Capture for AUSA**

##### **2.4.3.4.1 Observations**

One of the systems included in the CLCGF architecture was a data logger (see Figure 4.1). This data logger recorded every PDU (including Signal PDU's) generated by the CLCGF simulations. The logger also recorded CCSIL message traffic. These PDU's and messages could then be used to replay any or all of the simulation events. After the experiment, PDU's representing the approximately three and a half hour scenario could be extracted as required to create the simulation events need for the twenty-five minute AUSA presentation. For the AUSA the TSIU was linked to the data logger to translate the Aggregate, and Signal PDU's and CCSIL messages and pass them to C4I systems.

##### **2.4.3.4.2 Conclusions**

23 April 1998

The success of the CPSAA presentation at the AUSA General Meeting is testimony to the validity of the approach used for CLCGF data collection. Further, it demonstrated a potential to use similar data collection methods, together with the TSIU's translation capability, to support After Action Reviews (AAR's) for training exercises. This potential capability is described in the AE4 AAR and is discussed in more detail in paragraph 4.3.3.

**2.4.3.5 Objective 4 - Document Experimental results and lessons learned.**

**2.4.3.5.1 Observations**

Previous AE's have been documented by an AAR similar to the one published by TRADOC for AE4. These AAR's have documented the AE process and many lessons learned but they have not, for the most part, been technically oriented. For AE4, it was decided that a systematic documentation of the technical observations and experimental residuals was required to ensure that potentially valuable information was not lost. This report is intended to meet that requirement. It complements the AAR by focusing on the technical observations and lessons learned. The two documents together provide a complete record of AE4.

**2.4.3.5.2 Conclusions**

This section of the AE4 Experiment report documents the technical observations, residuals and lessons learned in the CLCGF Experiment and places it in the context of the other AE4 experiments. Together with the AAR, it provides a complete record of the CLCGF Experiment.

**2.4.4 Additional Observations and Findings**

The observations summarized in paragraph 4.2 are presented in more detail below. The source of each observation is identified by use of the following codes: O - Operator; DC - Data Collector; TS - Technical Support Personnel; and G - General. The data collection sheets from the experiment are contained in Appendix E. The electronic data from the experiment is archived at the OSF.

**2.4.4.1 Observation 1**

The TSIU demonstrated a capability to stimulate a full set of ATCCS and Appliqué systems from the Division to Platoon level from both aggregate and entity level simulations.

During the CLCGF Experiment the TSIU demonstrated the capability to pass information from a variety of DIS simulations<sup>4</sup> to the target C4I systems to include:

- Command and Control messaging (USMTF, VMF) to include:
  - blue force tracking(USMTF S507, VMF K5.01, CCSIL 201)
  - call for fire (VMF K2.04, CCSIL 401)
  - status reporting

---

<sup>4</sup> The simulations were: ModSAF, EADSIM, and the C4I Surrogate. The TSIU was also able to extract data from the Eagle Aggregate PDU which was created by the SIU.

23 April 1998

- Air and missile defense messages to include:
  - high and low altitude air picture (TADIL-B, FDL)
  - early warning
    - TBM
    - NBC
  - NBC (NBC-1,4, USMTF C488, VMF K5.61)
  - TBM (predicted impact point – FDL F-59, FDL F-60, FDL F-61, FDL F-62, FDL F-63, USMTF C121)
  
- Intelligence data to include:
  - SPOT report (VMF K4.52)
  - RECCEXREPs
  - SALUTE report
  - Red Order of Battle
  - JSTARS MTI
  - telemetry (UAV/JSTARS position)
  - TBM (estimated launch point, pairing with impact point)
  - TACELINT
  - ACE (USMTF S309)

#### 2.4.4.1.1 Conclusions

The TSIU demonstrated a capability to stimulate ABCS systems at each level of command from Division to Platoon. Extrapolating from its performance during the experiment, it appears that the TSIU has the capability to adequately stimulate the full suite of ABCS systems *providing that the necessary data can be generated by the simulation(s)*. That is, it appears that the TSIU's functionality is limited only by the availability of data.

#### 2.4.4.2 Observation 2 - TSIU "perceived truth" rather than "ground truth"<sup>5</sup>

The approach used by the TSIU to provide perceived truth versus ground truth was to extract data only from the DIS Signal Protocol Data Units (Signal PDU's) and from CCSIL messages generated either by ModSAF or the C4I Surrogate simulation.<sup>6</sup> This approach extracts the information from the Signal PDU's or CCSIL messages as necessary. The TSIU's role is to perform translation of the data provided by the simulations into the appropriate C4I message protocol and route that data to the intended C4I system(s). In AE4, the TSIU demonstrated a

---

<sup>5</sup> The meanings of "ground truth" and "perceived truth" are provided in paragraph 2.1.2.2.

<sup>6</sup> The ability to extract data from ModSAF generated CCSIL messages was a new capability for the TSIU that was developed for AE4.

23 April 1998

capability to serve as an interface between a simulation federation, which included both aggregate and entity-level simulations, and the ABCS C4I systems. Examples of how the TSIU functioned with various simulations is provided below.

- The TSIU read Aggregate PDU's produced by Eagle and the SIU. These PDU's represented ground truth on the location and status of the aggregate units being simulated in Eagle. The TSIU passed these PDU's to the C4I surrogate, which was simulating the Tactical Operations Centers (TOC's) for the aggregate units. The C4I surrogate applied a conversion to these PDU's to represent the errors and uncertainty in real world data. The converted PDU's were then translated by the TSIU into the appropriate tactical message and sent to the intended C4I system.
- The TSIU read CCSIL messages created by ModSAF entities and translated these into tactical messages. These CCSIL messages represented perceived truth from the perspective of the sending ModSAF entity. For example, a SALUTE report from a ModSAF entity would include only those enemy elements that had been detected by that entity using the appropriate ModSAF detection algorithms. Those enemy entities that could not be detected due to range, intervening terrain, or other factors would not be included in the message.
- The TSIU read Signal PDU's from the C4I surrogate. The C4I Surrogate provided simulation of all of the critical units and entities, such as unit TOC's and intelligence assets, not represented elsewhere, in the simulation federation. The C4I Surrogate played the role of several simulation federates that would be required to represent those elements not played in the "core" simulations (Eagle and ModSAF). Data sent from the C4I surrogate for intelligence systems such as JSTARS and UAV was derived from the sensor models in the C4I Surrogate. Although these models were low fidelity, they were sufficient to demonstrate the TSIU concept for providing perceived truth.

As mentioned previously, the TSIU did not model communications effects. Since none of the CLCGF simulations modeled communications, no communications effects, such as delay of messages, was imposed on the information provided to the C4I systems. Under the TSIU concept, communications effects would be calculated by a communications simulation federate and then imposed by the TSIU. Since no such communications federate was available for the CLCGF Experiment, this concept could not be demonstrated

#### 2.4.4.2.1 Conclusion

The TSIU demonstrated a viable approach for incorporating perceived truth data into a simulation-driven exercise. This approach assigns specific roles to the members of a simulation federation. The role of the interface (TSIU) is: to provide translation between simulations data and tactical message protocols, to route messages to the appropriate C4I systems, and to impose communications effects. The responsibility for providing perceived truth data to include the calculation of communications effects, rests with the simulations. The validity of this approach is dependent upon how well the simulations fulfill their role. It is beyond the scope of this report to conduct an analysis of the validity of the data provided by the CLCGF simulations. However,

23 April 1998

the data captured during the CLCGF Experiment is available to support such an analysis in the future. The TSIU did not impose communications effects on any of the simulation data because an appropriate communications model was not available. The MMAI did incorporate a communications effects model as described in paragraph 4.3.11. The MMAI concept for incorporating communications effects is very similar to the TSIU and indicates that the TSIU could have imposed appropriate communications effects had time and resources been available to integrate a communications model into the CLCGF federation.

#### **2.4.4.3 Observation 3 - TSIU 2-way information flow (SIM/C4I)**

Most of the data flow through the TSIU was one way from simulations to the C4I systems. Originally, enhancements were to be made to the TSIU to allow Appliqué operators to provide movement orders to simulated forces under their control. However, due to the aggressive AE4 schedule this feature could not be implemented in time. The requirements for performing this enhancement were sufficiently analyzed such that this feature could be added in the near future given available funding. The TSIU was enhanced to provide a translation of a VMF Call For Fire message (K2.04) generated at an Appliqué workstation to a CCSIL 401 message (Fire Request) for execution in ModSAF. During the demonstration it appeared that the translation was performed and the CCSIL 401 message was received at the ModSAF workstation; however, ModSAF did not react to this message. It appears that the problem was within ModSAF but the exact nature of the problem could not be determined.

##### **2.4.4.3.1 Conclusion**

It appears that the TSIU was able to successfully translate a VMF Call for Fire to a CCSIL message. Although a valuable capability, this is not a significant advance in the state-of-the-art since the VMF Call for Fire is a highly formatted message and other interfaces, such as the AFATDS SSM for CBS, have demonstrated similar capabilities. This is a potential task for future experimentation with the TSIU.

#### **2.4.4.4 Observation 4 - MSAC Casualty Generator**

ModSAF currently does not simulate personnel casualties. Thus, when a vehicle is damaged, there is no indication of the casualties incurred and, thus, no training opportunity for Medical commanders and staffs. The MSAC Casualty Generator is intended to address this deficiency. In AE4, detonation PDU's from ModSAF were read by the MSAC Casualty Generator which then determined the number and type of casualties via a probability table. Penetration, burn, and smoke inhalation casualties were modeled within the Casualty Generator and a Name, Rank, and Social Security Number (SSN) were assigned to support decisions regarding choice of medical treatment facilities, type of evacuation platforms, and other items of interest to the Medical commander.

##### **2.4.4.4.1 Conclusion**

Current versions of ModSAF do not represent casualties at a sufficient level of detail to provide training for medical support personnel. The MSAC Casualty Generator demonstrated an approach for adding this capability to ModSAF or other, similar simulations. By doing so, the MSAC has significantly increased the potential training audience that can be supported by simulation-based training. An important point is that the capability represented by the MSAC

23 April 1998

allows medical personnel to train alongside combat, combat support, and combat service support personnel in a realistic manner.

#### **2.4.4.5 Observation 5 - MSAC integrated to MCS**

The MSAC command module, integrated into MCS, demonstrated a capability to provide Situational Awareness to Medical commanders and staff.

The MSAC command module provides a map-based display with overlays, symbology, and other graphics capabilities to present red and blue force orders of battle, terrain details, routes, landing zones, and other data critical to Medical commanders. Using a Netscape implementation, MSAC allows users to click on various map icons to display the status of medical organizations at all levels of the battlefield to include medical treatment facilities, logistics, evacuation, and headquarters. Tools provided by MSAC gave Medical staff the ability to: task organize medical units with the capability to divert assets to critical areas of the battlefield, track all patients using digitized medical cards, and track the status treatments performed to virtual patients. Of the ten Medical functional areas, MSAC provided at least partial support for:

- Command and Control
- Evacuation (to include all ground and air evacuation platforms)
- Hospitalization
- Logistics, Blood, and Maintenance

##### **2.4.4.5.1 Conclusion**

In AE4, MSAC demonstrated the capability to expand Situational Awareness to include information of interest to Medical commanders and their staffs. This capability has the potential to improve the Medical decision-making process in the same manner that tactical Situational Awareness has for the maneuver commander. This capability, together with the Medical Casualty Generator described above also provides the opportunity to integrate medical personnel into training exercises with the rest of the staff. This not only enhances training for the Medical community but it also make training more realistic for maneuver commanders and their staffs. By introducing a requirement to include the planning for and implementation of casualty care, the MSAC adds an additional element of complexity and stress to the current training environment.

#### **2.4.4.6 Observation - MSAC mounted on ATCCS 2.0.**

Currently the MSAC has been fully integrated with the MCS/P beta version. As a "proof of concept" for AE4, a portion of the MSAC functionality was integrated into the Brigade level MCS baseline system (ATCCS Version 2.0.4). In the future it is anticipated that MSAC will be a module integrated as a part of CSSCS.

##### **2.4.4.6.1 Conclusions**

The MSAC demonstrated a capability to be hosted on representative ATCCS platforms. This indicates that it should be feasible to integrate the MSAC into a target system such as CSSCS without significant additional development work.

23 April 1998

#### **2.4.4.7 Observation - Vehicle Health Monitoring System (VHMS)**

One of the components of the VHMS evaluated in the CLCGF Experiment was the VHMS Module that is a Pentium based data acquisition tool located on the M1A1. at Eglin Air Force Base, FL. The VHMS Module collected data on the following vehicle parameters:

- Fuel
- Ammo
- Power train status
- Number 4 bearing oil scavenger temperature
- Number 5 and 6 bearing oil scavenger temperature
- Combustion gases temperature
- Temperature at the power turbine inlet

The temperature parameters were selected because they are indicators of potential catastrophic failures. The module recorded all parameter values in a database file. Whenever any of the parameter values exceeded a predetermined threshold or a given period of time elapsed the system sent the database file over a dedicated phone line via modem to the VHMS Workstation located at the OSF in Orlando. The VHMS Workstation, acting as a surrogate Appliqué, formatted a VMF Logistics Situational Report and forwarded it to the S1/S4 Appliqué at the Battalion TOC. The S1/S4 Appliqué combined this data with similar data from the other vehicles in the battalion, which were being played in simulation (see the discussion in the next paragraph), and forwarded a single Logistics Situational Report message to CSSCS at the Brigade TOC. The message is then incorporated in the CSSCS as Red, Green, Amber, or Black status for the weapon system. This alerts the CSSCS operator to a potential problem. The CSSCS operator can then use CSSCS's built in version of Netscape Navigator to query the VHMS for additional information. With this tool the operator can see which subsystem is causing the problems and drill down to the current status of the subsystem as well as a history for the subsystem. The intent of this capability is to provide maintenance personnel with near real-time information on system status to improve the timeliness of maintenance support and, potentially, to avert catastrophic failures by providing maintenance before the system fails.

##### **2.4.4.7.1 Conclusions**

Like the MSAC, the VHMS demonstrated a capability to support both training and operational applications. The intent of the VHMS, as demonstrated in the CLCGF Experiment, is to provide maintenance support personnel with detailed data on the status of each vehicle in a unit to support planning for and executing maintenance support.

#### **2.4.4.8 Observation - VHMS simulation-based training**

The connection from the Vehicle Health Monitoring System and the CSSCS was not tested end-to-end. The reasons for this activity could not be accomplished per the following paragraphs.

The VHMS interface was successfully linked to a live vehicle on a range at Eglin AFB and was able to exchange data from the VHMS to the tank and back. The information which the tank sent to VHMS was then successfully sent to an Applique which was configured in the Battalion S1/S4 role. The updates from the live vehicle successfully stimulated the Applique. The

23 April 1998

communication path from the Applique to the CSSCS could not be established initially during the experiment period.

The main reason for the failure of the communication link from Applique to CSSCS was a version incompatibility between the two systems. The Applique was integrated with ATCCS during the Task Force XXI DAWE. After this experiment the Applique interface to ATCCS was not utilized for future experiments, such as Division XXI AWE. The ATCCS systems used for the AE4 experiment were DAWE versions and could communicate successfully between the ATCCS. Since the Applique was not integrated with this new version of ATCCS, updates to the Applique and CSSCS databases were required.

During the course of updating the systems, time for the VHMS experiment ran out. After configuration of the Applique and CSSCS databases the two systems were able to communicate information concerning supply points. There was no time left to test the interface from the live tank through VHMS to the CSSCS. However since the Applique could communicate with the VHMS initially and after configuration the Applique communicated with CSSCS, it is believed that the linkage of live data through VHMS to CSSCS could have been accomplished given more time.

#### 2.4.4.8.1 Conclusions

Like the MSAC, the VHMS demonstrated a concept for using simulation to train support personnel. The intent of the VHMS Workstation is to provide realistic maintenance data to maintenance support personnel to allow them to practice the management of maintenance support assets.

#### 2.4.4.9 Observation - VHMS to populate Appliqué

While the VHMS interface communicated readily with the Appliqué the link between the Appliqué and the CSSCS was difficult for a variety of reasons. The major reasons for the difficulties encountered in the connection of the CSSCS with the Appliqué could be traced to incompatibility in databases between the systems. This problem was encountered in several instances during the CLCGF experiment. The major reason for the incompatibilities can be traced to the fact that the ABCS software utilized for the experiment was configured for the DAWE SIMEX 1. This exercise required a change in the Address Book and UTO databases. Since Appliqué did not play in this exercise the new addresses and databases on the ATCCS systems were not the same as those on Appliqué. This problem was resolved with changes to the address book and updates to the database. Another problem was the fact that CSSCS does item matching based on item description or nomenclature rather than item number. Therefore, if Appliqué lists an item as, "Tank, M1A1" and CSSCS has the same item in its database as "M1A1 Tank", CSSCS will not recognize the two as being the same item. This made the problem of reconciling the databases between Appliqué and CSSCS more difficult than if matching had been done using Line Item Numbers (LINS).

#### 2.4.4.9.1 Conclusions

The difficulties encountered in passing information between CSSCS and Appliqué highlight the need in future exercises for a standard Address Book which does not need to be changed for each different experiment. Similarly, a standard means for referencing database items between tactical C4I systems, preferably using an established numerical system such as LINS, would

23 April 1998

reduce the possibility of database incompatibilities and make any incompatibilities that do occur easier to identify and remove.

#### **2.4.4.10 Observation - MMAI interaction HLA & DIS federations**

The MMAI was actually an HLA federation based on version 1.0.2 of the HLA Runtime Infrastructure (RTI). The MMAI federation comprised the following three federates:

- The C4I system federate was responsible for directly communicating with the Appliqué, including the physical connection. The C4I Federate includes software used for translating messages between VMF and CCSIL. VMF messages coming from the Appliqué were translated to CCSIL and sent through the RTI to the Simulation federate (described below). CCSIL messages coming from the Simulation Federate were sent through the RTI and translated to VMF by the C4I Federate.
- The Simulation Federate software includes two basic components: the Simulation Interface that consists of CFOR client software capable of exchanging CCSIL messages; and the RTI Interface. The Simulation Federate also included a Position Server (PS) that was responsible for providing Situational Awareness data by realistically updating the positions of friendly entities. The PS simulation maintains the positions of friendly entities and the topology of the network structure based on the roles of the entities involved. The entity positions were obtained by subscribing to the Entity State PDU's published by the DIS federation. The PS simulation is a set of algorithms for determining when position reports are to be generated each of the friendly entities. The algorithms are based on the SA reporting scheme of the real Tactical Internet (TI). The PS simulation and server interface component are linked together within a single process.
- The Communications Effects Server (CES) is responsible for controlling the computation and application of the communications effects. It is considered the hub for the C2 message traffic within the architecture. The concept is that all C2 messages will pass through the CES federate on the way to their respective destinations. The CES federate is described in more detail in paragraph 4.3.1.11 below.

The MMAI federation interfaced with the CLCGF simulation architecture, a DIS federation, using DIS PDU's and CCSIL messages.

#### **2.4.5 Conclusions**

The CLCGF Experiment was one of the first demonstrations of an interaction between HLA and a DIS federations. This is important because of the mandate that all new simulations for the Department of Defense (DOD) be HLA compliant. By linking the MMAI to the CLCGF DIS federation, the CLCGF Experiment showed that an HLA federation can interact with a legacy, non-HLA compliant DIS federation through the use of appropriate interfaces or translators.

#### **2.4.6 Recommendations**

Evaluate the approach used by the MMAI to interface with the CLCGF DIS federation to determine if it has application for the development of WARSIM and other new simulations.

23 April 1998

### **2.4.7 Observation - MMAI Communications Effects Server (CES)**

The CES federate included a communications model that computed the communications effects based on the positions of the sender and receiver(s) and the intervening terrain. The communications model is referred to as the Communications Model Module (CMM). The CMM is a low fidelity model based loosely on the Tactical Internet (TI) scheme of communications. It combines deterministic and stochastic components to generate its results. Line of sight and propagation effects are computed deterministically using a terrain profile and the Terrain Integrated Rough Earth Model (TIREM). The network loading and delays associated with intranet communications in the TI are modeled stochastically based on System Performance Model (SPM) data generated by CECOM. The CMM does not explicitly model any of the radio systems found in the real TI. When a CCSIL message was generated by an entity in ModSAF or the MMAI Position Server generated a position report the positions of the sending and receiving entities were passed to the CMM. The CMM then performed the calculations necessary to determine if the message would be successfully transmitted. If the range or intervening terrain precluded communications, then the message was lost. In the case of position updates, the effect of lost transmissions could be seen on the Appliqué as vehicle icons changed color to indicate that the age of the information on their position had exceeded an acceptable value.

#### **2.4.7.1.1 Conclusions**

The loss of information due to communications effects is an important factor of the "fog of war". It is important for commanders and their staffs to learn to operate under realistic conditions of uncertainty. Many current simulations provide the training audience with information that is "too good" in part because the simulation does not incorporate communications effects. The MMAI CES demonstrated an approach for incorporating realistic communications into training simulations. The CMM was a fairly low-fidelity representation of the Tactical Internet and it did not incorporate some functions such as interference or jamming. However, it is not clear how much fidelity is "good enough" to accomplish meaningful training objectives. This issue should be addressed before developing more complex communications simulations.

#### **2.4.7.2 Observation - MMAI free text orders Appliqué to ModSAF**

The MMAI C4I Federate demonstrated a capability to translate simple, VMF free-text messages to CCSIL messages that were sent, via the CES, to ModSAF for execution. An operator on the company commander's Appliqué generated the free text messages. An example of the type of message that the C4I Federate could translate is, "First platoon move to checkpoint A". ModSAF would execute this message if: (1) the receiving entity (First platoon) had previously been assigned a movement route, and (2) that movement route contained a control point called "Checkpoint A". More complex messages such as, "First platoon move to a defensive position near checkpoint A", were not supported.

#### **2.4.7.2.1 Conclusions**

Most interactions between ground maneuver units occur as free text messages, often augmented by operations graphics. Current simulation-to-C4I system interfaces do not allow live players to send free text messages to units or entities within the simulation(s). Most systems currently require controllers to translate the messages generated by the training audience into a form that can be executed by the simulation. This approach increases the resources required to support a training exercise as well as increasing the potential for inducing errors in the simulation. In the

23 April 1998

CLCGF Experiment, the MMAI demonstrated a rudimentary capability that could be a first step in the development of interfaces that support true free text interactions between humans and simulations. There is still significant work to be done to refine this capability and expand it to include operations graphics. As was discussed above concerning the CES, it is not clear how much fidelity in free text interactions is required to support meaningful training objectives and this requirement should be defined before significant further development is undertaken.

#### **2.4.7.3 Observation - ModSAF 3.0 Eagle/SIU**

The SIU was originally developed to support the Joint Precision Strike Demonstration Advanced Concept Demonstration (JPSD ACTD). Subsequently, it was incorporated into the Joint Virtual Laboratory (JVL) at TRAC. It is a key component of the CLCGF architecture. The primary purpose of the SIU is to interface the Eagle and ModSAF simulations. It does this in two ways. First, it creates an Aggregate State PDU that is used to transmit to ModSAF information on the position and status of units being played at aggregate level in Eagle. This allows ModSAF to "ghost" those units. This means that ModSAF can display the location and movement of Eagle units but it does not control them nor can ModSAF entities interact directly with them. Secondly, it deaggregates Eagle units to individual entities that are then passed to ModSAF. When units are deaggregated, ModSAF controls the entities and these entities are able to fully interact with all other ModSAF entities. Furthermore, the SIU also passes to ModSAF the deaggregated unit's orders so that when the entities are created in ModSAF they know what to do.

The most recent version of the SIU was released just prior to the start of the CLCGF Experiment. This version had been developed to operate with ModSAF version 3.0, and was selected for AE4. Some problems were encountered with the operation of the SIU during the experiment. These problems were caused primarily by the fact that the software was new and relatively untested and that only limited technical support was available from the developer due to other commitments. The three major problems encountered are described below.

- Initial attempts to create the AE4 scenario were unsuccessful. The scenario was initially created in Eagle and ran without problem. However, when Eagle was linked to the SIU and ModSAF, the same scenario caused ModSAF to "crash" repeatedly. It was believed that the problem was incompatibility between the naming of unit and entity types between Eagle, the SIU, and ModSAF and the fact that ModSAF did not represent all of the systems in the AE4/4ID unit organization. Numerous attempts to resolve this problem were unsuccessful, primarily due to a lack of experienced technical support, and it seemed that the experiment would have to be run with older versions of ModSAF and the SIU. At the last moment the simulation developers at the JVL at TRAC volunteered to help solve this problem. Through their efforts, the incompatibilities between the simulations were resolved and alternatives were found for those systems not represented in ModSAF.
- The SIU was designed to perform deaggregation of Eagle under three sets of conditions: operator specified units could be deaggregated at game start, units could be automatically deaggregated when they entered a specified geographic area, or units could be deaggregated when they came within detection range of specified ModSAF entities. In AE4, only the first method of deaggregation was attempted. Once again,

23 April 1998

this was due primarily to the lack of dedicated technical support for the SIU. Without appropriate support it was considered too high risk to attempt "dynamic deaggregation" during the experiment.

- The SIU performed as expected when connected to an Eagle system to create aggregates and move these simulated entities about the battlefield. One feature, which has been used extensively in past experiments using the SIU, was the ability of creating aggregates directly on the SIU and moving these units via the ModSAF interface. This feature has been successful in rapid creation of scenarios in several previous exercises. With the new version of the SIU aggregates could be created on the simulated battlefield but could not traverse the battlefield. All efforts to solve the problem were unsuccessful.

Despite the problems encountered, the SIU successfully demonstrated an important capability; the linking of aggregate and entity-level simulations to represent different aspects of the same scenario. This capability allowed the AE4 scenario to be played at two different levels of resolution. The brigade that was used to stimulate the live TOC's in the experiment was played at the entity level of resolution while the rest of the units on the battlefield were "filled-in" by units played at a lower level of resolution in Eagle. This significantly reduced the simulation resources needed to support this division-level scenario.

#### 2.4.7.3.1 Conclusions

The capability represented by the SIU is a potentially important one. Combining aggregate and entity-level simulations allows a training exercise to be developed that is tailored to the needs of the training audience. That is, those elements of the scenario that are of high interest to the training audience can be played with higher resolution at the entity level while those elements of less importance can be played at an aggregate level. Playing units at an aggregate level reduces scenario set up time and data requirements and, thus, the resources required to conduct an exercise. The SIU's capabilities were not fully demonstrated during the CLCGF Experiment due to the lack of dedicated technical support. This is a lesson learned for future experiments and exercises that appropriate technical support must be planned for all critical software items especially if they are new and relatively untested versions.

#### 2.4.7.4 Observation - Eagle/SIU supporting unit deaggregation to entity level.

As described above, only one of three methods for unit deaggregation were demonstrated in the CLCGF Experiment. This method, the deaggregation of selected units at game start with no subsequent reaggregation, is called static deaggregation. This method was sufficient to support the tightly structured scenario used in the CLCGF Experiment. Scenarios used to support training exercises must be less structured to allow the evolution of the scenario to be dependent upon decisions made by the training audience. To support this type of scenario methods for dynamic deaggregation are required. Although the SIU is intended to support dynamic deaggregation, this capability was not demonstrated in AE4 for the reasons discussed above.

#### 2.4.7.4.1 Conclusions

Dynamic deaggregation is a difficult problem that must be solved if aggregate and entity-level simulations are to be combined to support training exercises. This is particularly true in the case

23 April 1998

of ground maneuver units which, when deaggregated, must have each of their entities placed on the terrain in locations that are tactically reasonable and which must provide each entity with a set of tasks that will allow it to continue to perform the unit's mission. The SIU probably demonstrates the current state-of-the-art in dynamic deaggregation for ground maneuver units. It is unfortunate that the CLCGF Experiment was not able to assess the extent of this capability.

#### **2.4.7.5 Observation - CPSAA presentation**

During the CLCGF Experiment the data logger captured all of the PDU's and CCSIL messages generated by the simulations. For the CPSAA presentation a subset of this data was selected to provide playback of the events that were depicted in the CPSAA scenario, which represented approximately twenty-five minutes of the over three hour CLCGF scenario. As in the experiment, the PDU's and CCSIL messages were sent to the TSIU that created the tactical messages that were used to stimulate the ABCS systems during the presentation. The CPSAA presentation was a successful demonstration of a "playback" capability inherent in the CLCGF architecture.

##### **2.4.7.5.1 Conclusions**

The playback capability demonstrated at the CPSAA presentation represents a technique that would be valuable to use in a training AAR. The ability to replay an exercise and review the decisions made at each critical phase and the results of those decisions is a potentially valuable learning tool. The fact that this capability is supported by the same simulation/interface architecture that was used for the original exercise makes it that much more valuable. It should be relatively easy to expand this capability by including the ability to playback the exercise to a critical point and then "going live" with the simulations to investigate the impact of different decisions on the outcome of the exercise.

#### **2.4.8 Residuals**

The "leave behind" architecture for the CLCGF experiment is well-suited for use in all three domains: Advanced Concepts and Requirements (ACR), Research, Development, and Acquisition (RDA), and Training Exercises and Military Operations (TEMO). It readily accommodates test and evaluation activities, human factors studies, and other applications primarily due to automated/semi-automated features which greatly reduce the manpower requirements for running an exercise. Residuals are discussed in Appendix F.

#### **2.5 DBBL Experiment**

The AE4 DBBL experiment was held from 15 August - 5 September at Fort Benning, GA. In the DBBL experiment, the common battlefield scenario was executed from platoon to the individual soldier levels. The primary interface evaluated was the tactical communications linkage between Land Warrior (LW) systems and an Appliqué system mounted in an M2 Bradley Simulator. As a part of the experiment, actual LW equipment was integrated with the various participating Individual Combatant (IC) virtual simulation systems with the objective of replicating the LW capabilities in the virtual environment.

A key component for the DBBL experiment was the successful integration of the virtual component with the LW system. This capability enables IC virtual simulations utilizing the LW system to participate in large and small scale ABCS exercises by providing soldier level tactical

23 April 1998

communications connections to Appliqué systems. The scenario was executed on the Fort Benning Military Operations on Urban Terrain (MOUT) database due to the requirement for use of a high fidelity database to support typical, IC operations.

During the final week of the experiment the DBBL experiment was "linked" (with respect to tactical communications) to the CLCGF experiment. On the last day of the DBBL experiment, the M2 simulator and corresponding Appliqué system were re-initialized using the Grafenfels database, and attempted to participate as a part of the CLCGF experiment.

### 2.5.1 Objectives

A total of seven objectives were identified for the DBBL Experiment. The objectives included the following:

1. Evaluate the LWS C4I subsystem interface to both the DIS network and to Appliqué
2. Develop and document the DBBL experiment process
3. Observe the performance of the simulations/simulators and other support systems
4. Link M2 Simulator with Appliqué to the CLCGF Experiment
5. Perform data log and capture for the Association of the United States Army (AUSA) convention in October 97.
6. Document and publish results and lessons learned
7. Provide feedback for future experiments

### 2.5.2 Component Descriptions

The following systems were the primary components participating in the DBBL experiment:

- LW Omni-Directional Treadmill (ODT). The LW ODT consists of the following main components: an ODT locomotion simulator, the 3D simulation software, and a Walk In Synthetic Environment (WISE).
- LW Soldier Visualization System (SVS). The LW SVS allows unrestricted live soldier posturing for standing, kneeling, crouching, and prone positions. Movement is accomplished by means of a "joy stick" mounted on the rear of the user's LW weapon.
- Dismounted Infantry (DI) Semi-Automated Forces (SAF). DI SAF is an Army SAF (based on "leathernet" -- a SAF developed by the United States Marine Corps) which features firing positions such as prone, standing, and kneeling, and features standard infantry task behaviors.
- Appliqué Interface (AI). The AI is a residual product from the Force Protection Experiment (FPE) III held in Fall 1996 and is used to populate Appliqué displays with position data.

Note: No enhancements were made to this application for the AE4 program. The TSIU and MMAI (mentioned earlier) offered additional capabilities over and above the AI in their interface with Appliqué systems (e.g., red force tracking (via spot reports), the automated implementation of "movement orders", etc.).

- LW Interface. The LW interface provides linkages between the LW system and the 3D simulation software, thus enabling LW equipped IC virtual players to fire upon and laze

23 April 1998

simulated targets, communicate with Appliqué systems in a simulated combat environment, and perform other required IC tasks.

- The LW system was developed for the Program Manager (PM) Soldier program, and is the primary system used to provide IC tactical communications in the DBBL experiment.

### 2.5.3 Observation 1 – LWS to Appliqué

There were two LWS interfaces assessed in the DBBL Experiment: a tactical interface between the LWS and Appliqué, and a simulation interface between LWS and the DIS network. Regarding these interfaces:

- The LWS interface system successfully provided the VMF conversions required for a two way Land Warrior System linkage to Appliqué. During the beginning stages of the experiment there were a number of incompatibility problems between the LWS and Appliqué systems, but in the end these were resolved. SPOT reports were sent from the LWS system to Appliqué that resulted in enemy icons being displayed on the target Appliqué system. In return, as entities populated the Appliqué system, these were displayed on the LWS system. However, only a small subset of VMF messages could be passed between the two systems
- The LWS interface successfully provided the data required to link the LWS prototype weapon system with the 3D visualization software for enabling LWS soldiers to lase and fire upon simulated targets.
- When LWS or Appliqué reports positions, either, they represent “ground truth” directly from the simulation/simulator and do not accurately represent real world position or status reports.

#### 2.5.3.1 Conclusions

The LWS interface demonstrated a good initial capability to interface the LWS with both Appliqué, thus providing a gateway into ABCS, and the DIS network, thus providing a gateway into future simulation exercises. The interface requires further development to make it more robust and to incorporate the full set of VMF messages. In addition, the PDU information could be modified to address “ground truth” limitations, perhaps by delaying messages, by means of a communications effects server, or adding “noise” to the PDU-supplied information to more accurately represent real world accuracy limitations.

#### 2.5.3.2 Observation 2 - DI SAF

The DI SAF system performed reasonable well, but exhibited some anomalies in DI behavior.

The ODT/3D simulation system performed well, but is disconcertingly loud.

The SVS performed acceptably and had good stability.

The DI SAF, SVS, and ODT/3D simulation systems were linked together and demonstrated a potential capability to support infantry team training exercises.

The Appliqué system used in the experiment was actually Appliqué software mounted on a commercial laptop. This system proved to be very fragile and crashed often.

Soldiers had problems using LWS and Appliqué in the high-resolution DBBL scenario because of problems with maps of the McKenna MOUT site and surrounding area. Small scale maps of

23 April 1998

the area were not available for loading into the C4I systems, and the Appliqué and LWS maps are not scaleable. In addition, map downloads to LWS took almost half an hour.

Due to the timely and successful integration of the IC simulators, the visual system contractor took the initiative to fully integrate the Grafenfels database on both the SVS and ODT simulators. This offered additional residual benefit for the DBBL given that many of the current large scale digitization exercises are being performed in areas surrounding Grafenfels. However, it should be noted that the resolution of the terrain data in Grafenfels is not sufficient to support dismounted infantry requirements.

### **2.5.3.3 Conclusions**

The DBBL Experiment demonstrated an ability to link heterogeneous virtual Dismounted Infantry (DI) simulators and DI SAF to conduct a platoon level dismounted exercise. This is representative of the type of capability that will be required by both the Army and the Marine Corps for training and mission rehearsal.

There is still noise within the user interface and control issues with the ODT/3D simulation software system.

Both Appliqué and the LWS are currently limited to a small number of pre-loaded or downloaded fixed-scale maps. During exercises or missions in a confined area, such as the MOUT used in these experiments, these maps will not provide the user with good situational awareness.

The SVS performed well, especially considering the relatively low cost of this PC-based system.

### **2.5.3.4 Observation 3 – Data Logger**

An automated tool (Simulyzer) was used to build PDU log files from executing DIS simulation traffic. These PDU logs were then used to populate the Appliqué screens at the AE4 CPSAA presentation through the use of the TSIU as described in paragraphs 4.2.3 and 4.3.3. It was not possible to populate the LWS screen with simulation data at the CPSAA presentation because there were not sufficient resources to develop a TSIU translator for the LWS. Therefore, representative LWS screens were shown at the presentation.

### **2.5.3.5 Conclusions**

Applicable network traffic was successfully data logged for editing/playback for the CPSAA presentation.

As noted in previous paragraphs, the log files could have also been used in an after-action reporting mode using a stealth in a playback mode.

### **2.5.3.6 Observation 4**

This report is intended to serve as the documentation of the results and lessons learned from the DBBL Experiment. As noted in paragraph 5.1.6, the data collection process for the DBBL Experiment was less formal than was the case for the CBS and CLCGF Experiments. To compensate for this, the observations included in this section were reviewed by a broad range of experiment participants to ensure that these observations are as objective and accurate as possible.

**2.5.3.7 Conclusions**

Despite the somewhat informal nature of the data collection process, the observations included in this report provide a good representation of the results of the DBBL Experiment. Although detailed analysis of the experiment was not possible, the observations provided are of sufficient detail and objectivity to provide a basis for decisions on future system development and employment.

**2.5.4 Residuals**

The “leave behind” architecture for the DBBL experiment will support IC operations and tactical communications to the individual soldier level. It is well-suited for use in all three domains: ACR, RDA, and TEMO, and will readily accommodate test and evaluation activities, human factors studies, and other applications related to IC areas of interest.

Residual components that resulted from the Army Experiment 4 DBBL experiment are listed in the table below:

**Table 2.8.5-1 DBBL Experiment Residuals**

<b>Residual Component</b>	<b>Recipient</b>
SVS	STRICOM/DBBL
ASTi DIS Radio Network (6 stations)	STRICOM/DBBL
LWS integration with SVS and ODT simulators	STRICOM/DBBL
LWS integration with Appliqué	STRICOM/DBBL
Appliqué integration with SIMNET M2 simulator	STRICOM/DBBL
MOUT database integration with SIMNET M2 simulator	STRICOM/DBBL

**3. AE4 Presentation**

**3.1 Overview**

The AE4 Presentation was held at the AUSA Conference in the Cotillion Ballroom of the Sheraton Hotel 13-15 October 1997 in Washington, D.C. The AE4 Presentation had two purposes: 1) to review results of the AE4 experiments held in August and September and 2) to preview situational awareness in a Full Spectrum Force XXI, focusing on seamless command and control from the division level to the individual soldier. The primary TRADOC messages for the AE4 presentation were the following:

- 1) SA is the key enabler for the Full Spectrum Force
- 2) Investment in Army XXI, the necessary foundation for Army After Next (AAN), is critical
- 3) There exists a large margin of improvement in SA for Division XXI

23 April 1998

The objective of the AE4 Presentation was to generate enthusiasm in visitors for what they saw in the theater and command post situational awareness area. The primary purposes of the presentation were to:

- 1) Chronicle the development and impact of changes in the technology of warfare that have had an impact on situational awareness and command and control;
- 2) Provide historical and background information on Force XXI processes;
- 3) Stimulate thinking about the value of situational awareness;
- 4) Provide a comparison of current "paper" means of maintaining situational awareness (e.g. maps) and Army XXI digitized means (e.g. ATCCS, Appliqué);
- 5) Provide background for the theater and CPSAA scenarios.

The physical layout and traffic flow for the AE4 Presentation is illustrated in Figure 4.

## Visitor Flow

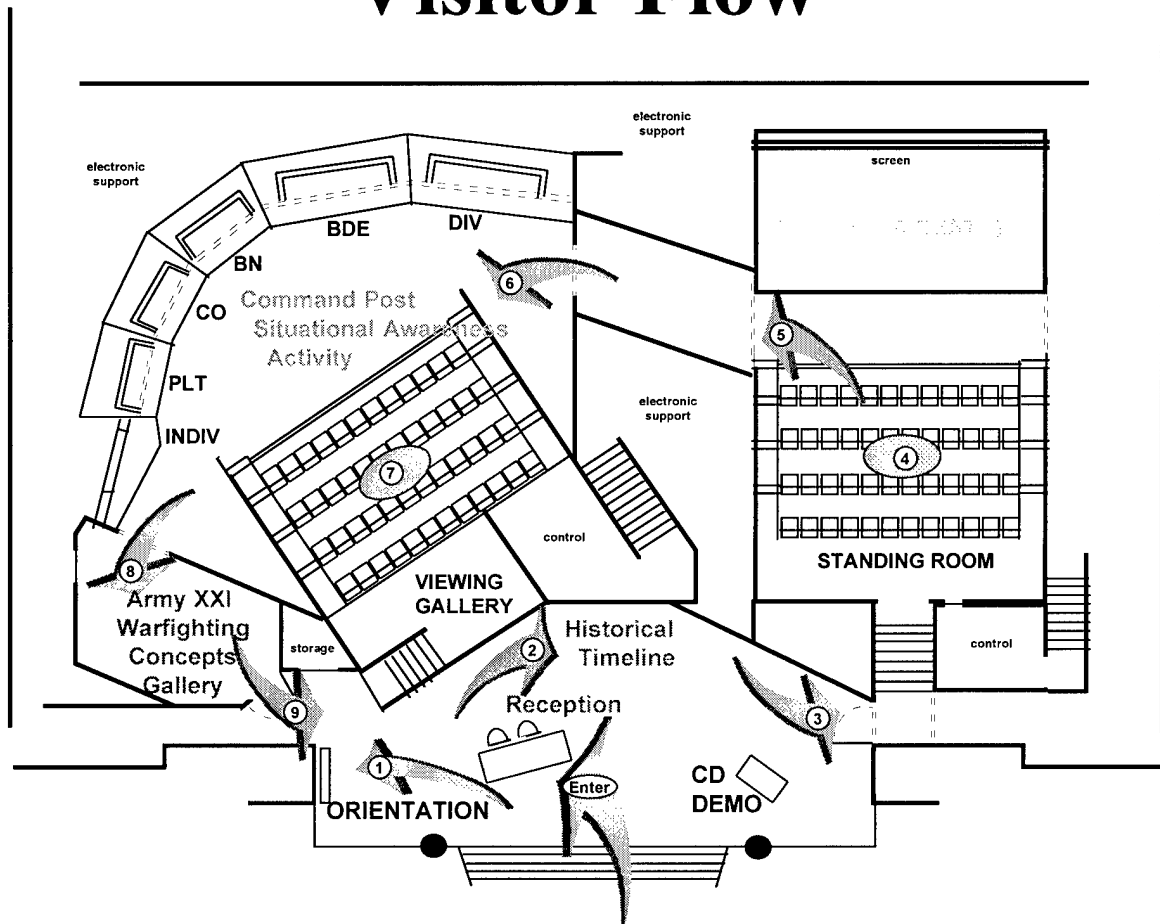

Figure 3.2-1 AE4 Presentation Facility Layout and Traffic Flow

The facility is composed of three major areas: the Reception Area, the Theater, and the Command Post Situational Awareness Activity (CPSAA) Area. Traffic flow is counterclockwise through the Reception Area, the Theater and the CPSAA Area. Each area is summarized below.

23 April 1998

### **3.2 Reception Area**

The Reception Area (Figure 4, lower middle) consisted of a reception desk, a VIP start area, a timeline providing a graphic history of situation awareness along the front of the exhibit wall, and a CD ROM demonstration area. The historical timeline provided a chronicle for the development and impact of changes in the technology of warfare that have had an impact on SA and C2.

### **3.3 Introduction Theater Area**

The Intro Theater Area (Figure 4, upper right) featured video presentations. The presentations were projected on three screens in a multi-media presentation. The video presentations provided a history of Force XXI (where we've been), explanation of the AE4 experiments (where we are), and insight into Army XXI systems which enhance SA (where we are going). The video presentations delivered the main message of a Full Spectrum Force ready for deployment to a wide variety of missions across the full spectrum of military operations. The special emphasis was on situational awareness in Army XXI as demonstrated in a common battlefield scenario. The video presentations provided an introduction to the main feature, the CPSAA.

### **3.4 Command Post Situational Awareness Area (CPSAA)**

The CPSAA (Figure 4, left top) consisted of a gallery, and a stage area—where the experimental exercise is replayed to dramatically portray situational awareness in the Full Spectrum Force, and a CD distribution area at the front. The CPSAA was used to present Army XXI SA tools currently available to commanders and staffs from Division to the individual soldier level, demonstrate how Army XXI C4I systems and SA tools shorten and improve decision making process, and to illustrate how SA facilities dynamic execution of changed plans with minimal confusion in a battlefield scenario.

The stage area consisted of 6 booths representing the echelons of command from the division to the individual soldier level. The division was played by two role players with access to the division tactical systems exercised in the experiments, as outlined above. The Division level mock-up featured the 4th Infantry Division (4ID) Commander's Information Center (CIC). The brigade level was played using a C2V mock-up, with three live players who have access to equivalent tactical systems. The Battalion level was played by two live players in a mock-up BCV CP with similar systems. The Company level was played by a live company commander in an M1A1 mock-up with an FBCB2 system. The platoon level was played by a live Platoon Sergeant in an M2A2 mock-up with an FBCB2 system. A live Squad Leader dressed in land warrior equipment to include the land warrior system used for tactical command and control communications played the Individual soldier level.

As the scenario was initiated, the spotlight focused on the division commander, reviewing, on his tactical systems, the division's plan of attack. As the scenario progressed, he digitally requests a plan change of Corps based on new G2 of the enemy reinforcing his objective and leaving the northern border with weakened defenses. As the scenario unfolded, the spotlight moves from echelon to echelon highlighting the seamless digital flow of information critical to situational awareness for Army XXI. The command stream was followed down the command hierarchy,

23 April 1998

from system to system, and the report stream was followed back up the command hierarchy on the same systems.

A full script for the CPSAA is provided in Appendix B.

### **3.5 Demonstration Execution**

#### **3.5.1 Hotel and Union Labor**

Lockheed Martin contracted with the Sheraton Washington Hotel and Greyhound Exposition Services (GES) for services required to prepare the Cotillion Ballroom for Army Experiment 4. These services included air conditioning, electrical power, telephone connections, network connections, tables, draping, and labor for installation, dismantling, and handling of equipment (unloading and loading trucks).

#### **3.5.2 AE4 Teardown Pack and Ship**

The planning for teardown packing and outbound shipping was discussed in detail during IPR's August and September. The final plan was executed on the last day of the demonstration, Wednesday 15 October, ITS began their strike at 4pm. The audio/video equipment was struck that enabled the ECI teardown team to breakdown the theaters. All AE4 ADSTII items were tagged for later inventory.

The day after the demonstration, Thursday 16 October, all equipment was packaged in its original crates or boxes. All equipment was crated and packaged in a safe and secure manner to prevent any damage during shipment. All Equipment was packed and not shipped loose. The equipment retained its original crate number for tracking.

##### **3.5.2.1 HVAC**

Lockheed Martin provided a cooling requirements analysis for both the Introduction Theater and the Command Post Situational Awareness Area. Based on that analysis, the appropriate cooling services were contracted with the Sheraton .

#### **3.5.3 Power**

Lockheed Martin provided a power requirements analysis for all elements of the AUSA. Based on that analysis, the appropriate power services were contracted with the Sheraton. The requirements were for three separate sources of power. The power distribution was discussed and planned for between Lockheed Martin engineering, Image Technical Services, Exhibit Crafts, and the Sheraton hotel services. The requirements were as follows.

- **Three Separate Power Sources (A, B, C)**
- (45) 110 VAC, 1ph, 20 amp Quad Outlets, NEMA 5-20 (Source A)
- (1) 220 VAC, 1 ph, 30 amp Outlets, NEMA L6-30 (Source B)
- (1) 220 VAC, 1 ph, 60 amp Outlets (Source B)
- (1) 220 VAC, 3 ph, 30 amp pigtail, (This is a Sheraton supplied A/C Unit used in the Intro Theatre; this is the same unit used in the October AUSA Demonstration 1996) (Source C)

**3.5.3.1 Telephone/DataFax**

Lockheed Martin ordered and supplied dial-up telephone services and instruments from the Sheraton. There were two phone lines installed in the south side tech room area for voice and fax. ADST supplied a BROTHER FAX/Copier/Printer in the admin tech room and utilized this unit for administrative purposes. The analog instrument for the intro theater tech room phone #2 & #3 and the admin room phone # 14 was replaced with 900 MHz cordless phones. Figure 3.5.3.1-1 represents the distribution of analog telephone lines throughout the Cotillion Ballroom.

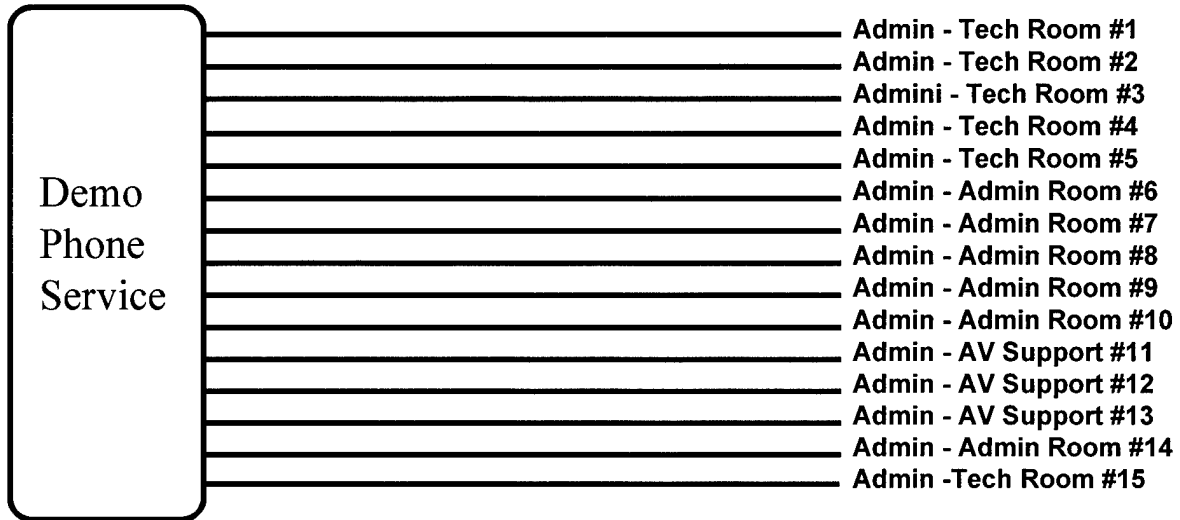

**Figure 3.5.3.1-1 AE4 Telephone Distribution**

Figure 3.5.3.1-2 depicts the AE4 demonstration distribution of the hand held 2-way radios. The radios were used religiously through installation, integration, demonstration and tear down.

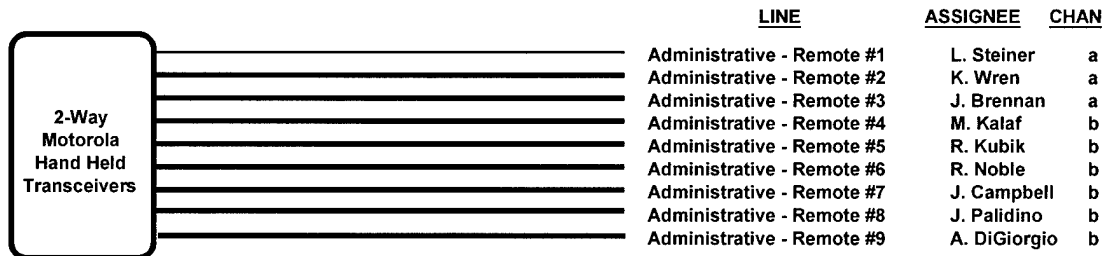

**Figure 3.5.3.1-3 AE4 2-Way Radio Assignment**

**3.5.4 Exhibit Support**

**3.5.4.1 Perimeter Drapes**

Lockheed Martin arranged, through Greyhound Exposition Services (GES) the black perimeter drapes for a small section of the AUSA at the Cotillion Ballroom.

**3.5.4.2 Furniture**

Lockheed Martin arranged for all custom furniture to be designed and built by Exhibit Crafts Inc. Folding tables and chairs were provided by the Sheraton.

**3.5.4.3 Introduction Theater**

Lockheed Martin arranged for, through ECI, based on designs received from the Exposition Conceptual Designer, an appropriate ramp and audience seating for the intro theater. Lockheed Martin arranged for, through ECI, based on designs received from the Exposition Conceptual Designer, an appropriate enclosure for the intro theater.

**3.5.4.4 Carpet**

Lockheed Martin arranged for, through ECI, based on designs received from the Exposition Conceptual Designer, appropriate carpeting for the theater.

**3.5.5 Audio Video Support**

The audio/video (AV) support for the rehearsals and the demonstration was provided by Image Technical Services (ITS). The AV support was included in the Introduction theater and the Command Post Situational Awareness Area (CPSAA). The following figures illustrate the AV network diagrams. Figure 3.5.5-1 represents the Introduction theater AV network layout.

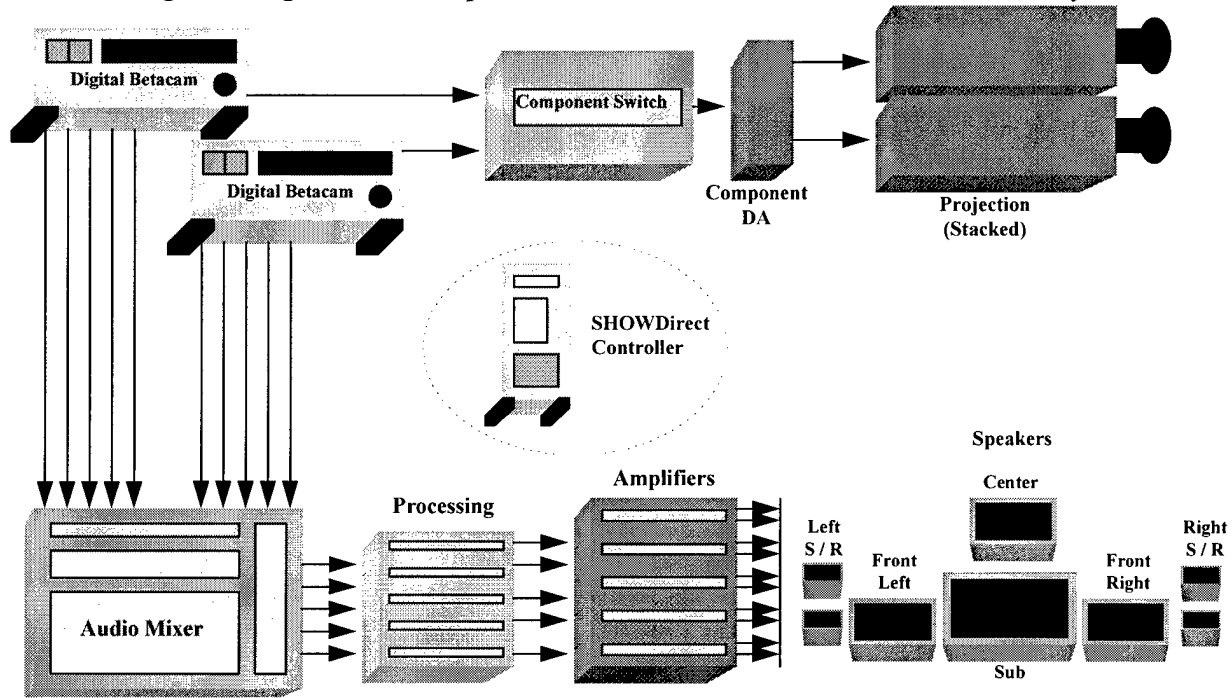

**Figure 3.5.5-1 Introduction Theater AV Network Layout**

The CPSAA AV is represented in figure 3.3.9-2.

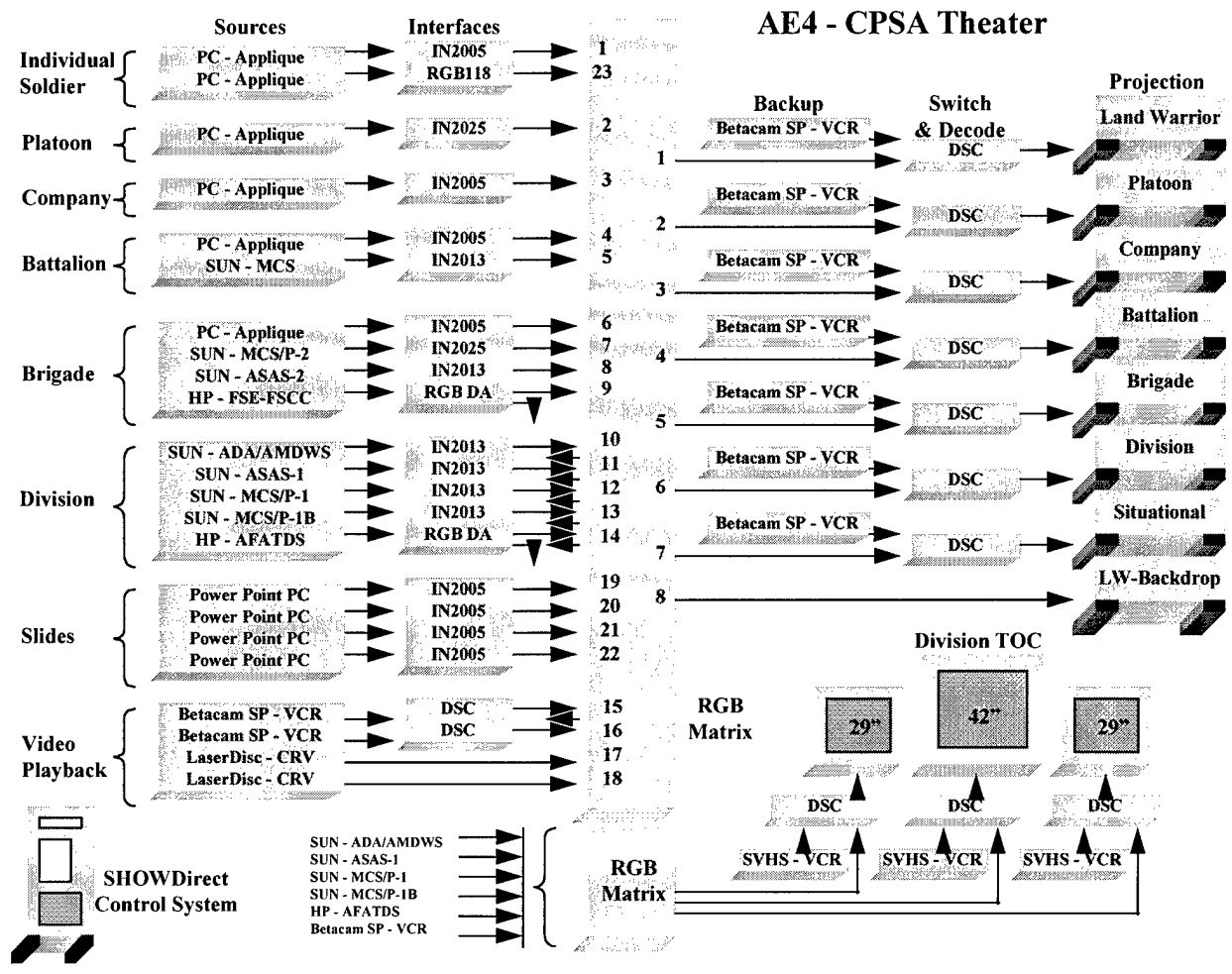

Figure 3.5.5-2 CPSAA AV Network Layout

3.6 Lessons Learned

After a group of people toured both theaters a common question that was asked was “what was stimulating the tactical systems during the CPSAA demonstration?”. The demonstration did not emphasize the experiment’s objectives...simulation to tactical system interfaces. There was not a comprehensive message told summarizing the Army Experiment 4 experiments. The simulation – ATCCS interfaces evaluated was never brought out in October AUSA. A recommendation would be to have brought forth the simulation and interfaces that were driving the ATCCS at the October demonstration and throughout the AE4 experiments.

3.7 Conclusions and Recommendations

- 1) The demonstration should emphasize and exploit the experiments. This could be done by starting the experiments earlier and build the criteria with the demonstration in mind. The experiments can be designed to make sure we collect the appropriate data for the demonstration. A recommendation would be to develop a campaign plan to identify and initiate the future AE’s earlier in the year. This would allow an earlier sign up for participants and users.

23 April 1998

- 2) If possible the Cotillion Ballroom needs to be leased out with a minimum of 5 full days of setup and rehearsal time. The installation, integration and rehearsal had to be accomplished within the 4 days for AE4. This created 18 – 24 hour work days including short tempers and confusion. It is a premium price for the installation labor.
- 3) The AE4 presentation was organized through the ADST II contract vehicle with the exception of the multi-media section. This included the introduction video and the CD ROM. These items were contracted through CECOM to Coleman Research Corporation (CRC). The observation was that the multi-media section was not closely tied to the Experiments and therefore did not summarize the significant events that occurred throughout the program. The introduction video was also disjointed from the audio video rehearsal schedule and was not observed until the day before the Chief walk through a month later than needed. The recommendation would be to have one central chain of command that would enable the fluid integration of the presentation.
- 4) Avoid simultaneous installation/setup and rehearsal.
- 5) Recommend a more detailed construction schedule with required milestones.
- 6) The exhibit construction setup needs to have a final walk through with customer, contractor, designer and builder.
- 7) There were some missed dimensions within the exhibit that created more on site modifications that were not proposed. A new site survey drawing needs to be constructed with very accurate dimensions.

## 4. AE4 Planning and Management

The Program Management that LMC performed was in accordance with the STRICOM Statement of Work for Army Experiment IV, (AE4), Proof of Principle, 22 May 1997, Rev 2.1. This included program management support for the attendance of In-Process Reviews (IPR's), Scenario Development meetings, Technical Interchange Meetings (TIM's), and other meetings required to support the AE4. LMC analyzed the schedule and determined problem areas as soon as possible and took corrective actions as required. STRICOM provided responsible personnel at the LMC facility throughout the AE4 program. This function enabled immediate attention to possible out of scope issues.

### 4.1 Program Organization

AE4's program organization is depicted in Figure 4.1-1 below.

**Figure 4.1-1 AE4 Organization**

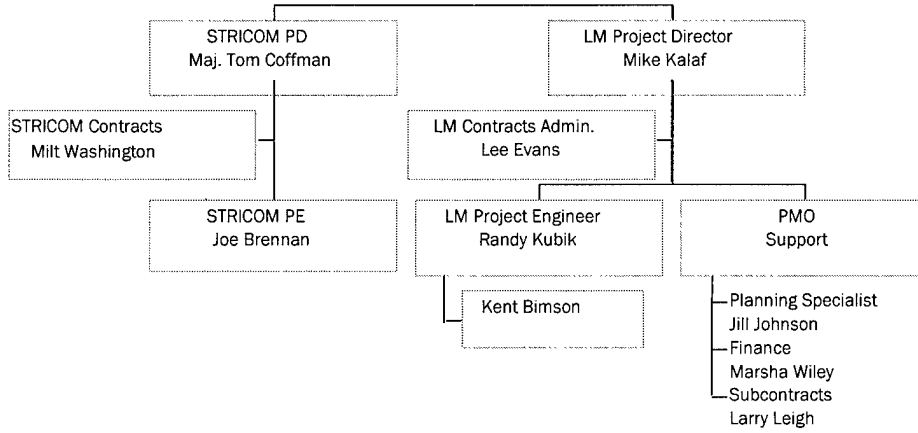

23 April 1998

**4.2 Reporting**

LMC provided written visibility into the AE4 team activities through the weekly Contractor Progress, Status, and Management Reports and the monthly Program Status Reviews.

**4.2.1 Contractor Progress, Status, and Management Report**

A Contractor Progress, Status, and Management Report (CPSM) was sent to the Government weekly. This report included information relating to the progress made on each task and the current status of each task.

**4.2.2 Contractor Cost/Schedule Status Report**

A Cost/Schedule Status Report (C/SSR) was sent to the Government monthly. This report included information relating to the current expenditures made. The format of this report was generated IAW DI-F-6010A and the accepted LMC contractor formats.

**4.2.3 4.3.3 Program Management Reviews**

The AE3 team supported Program Management Reviews (PMR's) as required during the conduct of the proposed efforts. PMR's were held as required by the Government.

**4.2.4 Scheduling**

Scheduling was updated and maintained by the LMC management team. The scheduling process enabled the customer and LMC upper management the detailed milestones to be met.

**4.3 In Progress Reviews (IPR)**

In preparation for AE4 there were a total of nine In Progress Reviews (IPR). Items presented at the IPR's were the following: design status; participant's status; integration and test schedules; move-in status; transportation status; and miscellaneous topics.

**5. Points of Contact**

The primary points of contact for this after action report are the following:

<b>Name</b>	<b>Organization</b>	<b>Phone</b>	<b>email</b>
Joe Brennan	STRICOM	407.384.3855, DSN 970	Joe_Brennan@stricom.army.mil
Mike Kalaf	Lockheed Martin Corp	407.306.4051	mike.kalaf@lmco.com
Kent Bimson	SAIC	407.306.5631	kent.bimson@lmco.com
Randy Kubik	AEgis	407.306.4417/380. 5001	rkubik@aegisrc.com
Billy Potter	LMSG	706.682.5300	billy.h.potter@lmco.com

# Appendix A – Master Schedule

Task Name	1997												1998														
	Jan	Feb	Mar	Apr	May	Jun	Jul	Aug	Sep	Oct	Nov	Dec	Jan	Feb	Mar	Apr	May	Jun	Jul	Aug	Sep	Oct	Nov	Dec	Jan	Feb	Mar
UDO Award		↑ 3/6																									
POP Award							↑ 7/3																				
IPR's									↑ 9/24																		
CBS Exp								↑ 8/15																			
CLCGF Exp								↑ 9/5																			
DBBL Exp								↑ 9/5																			
Rehearsal									↑ 10/3																		
OCT AUSA									↑ 10/16																		
CDRL AB004																											
AE4 Hot Wash										↑ 11/20																	
AE5 Concept Approval																											
AE5 Funding Received																											
AE4 POP																											

# Appendix B - Scenario Documentation

## Introduction

The AE4 scenario discussed in Section 3 of this document is supported by the following information in this appendix:

- Task organization and startex positions for the BLUFOR
- Task organization and startex positions for the OPFOR
- Battlefield geometry
- Routes
- Mil list

Each of these is presented below in table format.

### BLUFOR Task Organization and Startex Positions

STARTEX POS	AS OF 1171700 JUL 97				
SERIES 1501 ED					
6-DMG 1:250,000					
MAPS NM-32-9,12					
33-7,10					
EUROPAICHES					
DATUM 1950 (ED50)					
	DIV CRP	BDE CRP	BN CRP	CO CRP	PLT CRP
		DEAGGS	DEAGGS	DEAGGS	DEAGGS
		WITH (1BDE	WITH (1-22	WITH (B/3-	WITH (1/B/
		ONLY)	ONLY	66 ONLY)	1-22 ONLY)
TASK ORGANIZATION	STARTEX LOC				
4ID TAC	33U TQ851520				
1BDE	33U UQ205514				
1 RECON TRP	33U TQ910560				
1-22IN (M)	33U UQ070517	1-22 TOC	1-22 TOC		
		SCTS 1-22IN	SCTS 1-22		
		MORT 1-22IN	MORT 1-22IN		
			1/MORT 1-22IN		
			2/MORT 1-22IN		
		A/1-22IN	A/1-22 HQ		
		B/1-22IN	1/A/1-22		
		D/1-22IN	2/A/1-22		
		B/3-66AR	3/A/1-22		
			B/1-22 HQ		
			2/B/3-66		
			2/B/1-22		
			3/B/1-22		
			B/3-66 HQS	B6,B7	
			1/B/3-66	B11-14,	

23 April 1998

			3/B/3-66	B31-34	
			1/B/1-22	B11-14,	B11,B12
				1/2/A/1-44D	B13,B14
			D/1-22 HQ		
			1/D/1-22		
			2/D/1-22		
			3/D/1-22		
			1/2/A/1-44AD		
			2/2/A/1-44AD		
			1-22 CBT TRNS		
		1/1/A/1-44AD			
		2/1/A/1-44AD			
A/299EN	33U UQ070517		A/299EN		
		1-22 CBT TRNS			
3-66 AR	33U UQ292421	3-66 TOC			
		SCTS /3-66AR			
		A/3-66AR			
		C/3-66AR			
		C/1-22IN			
		D/3-66AR			
		1/2/A/1-44AD			
		2/2/A/1-44AD			
		3-66 CBT TRNS			
A/1-44AD(-) (DS)	33U UQ250840				
A/2 CM (DS)	33U UQ183478	299EN(-)			
299EN(-) (OPCON)	33U UQ183478				
A/104 MI (ACT)	33U UQ185528				
1/4 MP CO (DS)	33U UQ336304	4FSB(-)			
4 FSB(-)	33U UQ336304				
2 BDE	33U TQ822434				
2 RECON TRP	32U PV986431				
2-8 IN (M)	32U QV100425				
1-67 AR	32U QV108352				
3-67 AR	33U TQ948405				
3-16 FA (155MM0 (DS)	32U QV999410				
214 FA BDE (GS 4ID ARTY)	33U TQ927484				
(TACON FOR MOVT)					
2-4 FA (MLRS)	33U TQ815369				
4/C/2-20 FA (Q37)	33U TQ815369	2-4 FA			
1-14 FA (MLRS)	33U TQ815455				
5/C/2-20 FA (Q37)	33U TQ815455	1-14 FA			
5-3 FA (MLRS)	33U TQ959370				
232 TAD (2XQ37 DECEPT)	33U TQ959370	5-3 FA			
C/2-365 AD (OPCON)	33U TQ927484	214FA BDE			
B/2 CM (DS)	33U TQ910392	588 EN(-)			
B/1-44AD (-) (DS)	33U TQ822434	2BDE			
588 EN (-)	33U TQ910392				
B/104MI (ACT)	33U TQ822434	2BDE			
2/4 MP CO	33U UQ107406	204 FSB			

204 FSB	33U UQ107406			
3 BDE	33U TQ908702			
3 RECON TRP	32U PV976655			
1-8 IN (M)	32U QV100653			
1-68 AR	33U TQ923716			
1-66 AR	32U QV169577			
3-29 FA (155MM) (DS)	33U TQ947650			
138 FA BDE (GS 4ID ARTY)	33U UQ000639			
TACON FOR MOVT)				
1-181 FA (MLRS) (GS)	33U TQ947575			
4/231 TAD	33U TQ947575	1-181 FA		
1-623 FA (MLRS) (GS)	33U TQ973675			
5/231 TAD	33U TQ973675	1-623 FA		
B/3-265 AD (OPCON)	33U UQ000639			
C/1-44AD (DS)	33U TQ908702	3 BDE		
C/2 CM BN (DS)	33U TQ956608	397 EN		
397 EN (C) (M) (OPCON)	33U TQ956608			
C/104 MI (ACT)	33U TQ908702	3 BDE		
3/4 MP CO (DS)	33U UQ137652	64 FSB (-)		
64 FSB (-)	33U UQ137652			
4 BDE	33U UQ236570			
A/1-12 IN (M) (TACON FAARP SECURITY)	33U UQ236570			
1-4 AVN (ATK)	33U UQ182580			
2-4 AVN (-)	33U UQ314535			
1-6 CAV (OPCON)	33U UQ034530			
3-6 CAV (OPCON)	33U UQ275225			
2/20 FA (MLRS)	33U TQ845645			
1-10 CAV	33U UQ290170			
1/A/1-44 AD (DS)	33U UQ290170			
C/299 EN	33U UQ290170			
DIV TRPS				
1-12 IN (M) TCF	33U UQ923000			
4ID ARTILLERY	33U UQ048593			
4-42 FA (155MM) (GS) (O/O DS 1 BCT)	33U UQ022544			
3-18 FA (155MM)	33U TQ832491			
1-214FA (155MM)	33U TQ947558			
1-44 AD (-) (GS)	33U UQ113467			
2 CM BN (-) (DS)	33U UQ245355			
ENG GRP, 4ID	33U UQ245355			
493 ENG GRP (OPCON)	33U UQ245355			
478 EN (C) (M)	33U UQ245355			
586 EN CO	33U UQ245355			
4 MP CO (-)	33U UP964978			
2175 MP CP (GS)	33U UP964978			

23 April 1998

124 SIG BN (-)	33U UQ074370				
DISCOM	33U UQ923000				
704 DSB	33U UP964978				
REFUEL SITE GRIDS	32U PV956764				
	32U PV956738				
	32U PV986764				
	32U PV986738				
ENEMY MINEFIELD GRIDS	32UPV 926758				
	32U PV926764				
	32U PV931764				
	32U PV931758				
DBBL SITE - SCHWEND	32U PV915720				
TK AMBUSH SITE					
SCENE 42-45	32U PV891762				
SCENE 37 CHEM					
DANGER AREAS					
	32U PV936795				
	32U QV115535				
FLANK UNITS					
3ACR	33U UR560130				
1/3ACR	33U UQ200890				
ACAV1	33U UQ009818				
ACAV2	33U UQ009818				
3BDE 22 ID (M)	33U TQ915275				
1-39IN (M)	32U QV135266				
1-13IN (M)	32U QV04218				
1-29 FA	32U QV161175				
OTHER UNITS					
SCENE 29 MAINT/					
FUEL TRUCKS					
CONVOY 1	32U QV146546				

**OPFOR Task Organization and Startex Positions**

STARTEX POS					
SERIES 1501 ED		AS OF 111700 JUL 97			
6-DMG 1:250,000					
MAPS NM-32-9,12					
33-7,10		SOLDIER CRP SUPPLIED BY DBB			
EUROPAICHES					
DATUM 1950 (ED50)					
DIV CRP	GRIDS	1 BDE CRP	GRIDS	1-22 IN BN CRP	GRIDS
10 MRD	32U QV732747				
100 MRR	32U QV750444				
1BN100MR	32U PV774407				
2BN100MR	32U PV774495				
3BN100MR	32U PV 766574				
TK100MR	32U PV694548				
ART100MR	32U PV724458				
AT100MR	32U PV778315				
REC100MR	32U PV837444				
101 MRR	32U PV729680				
1BN101MR	32U PV770643				
2BN110MR	32UPV778694				
3BN101MR(-)	32U PV765778	3BN101MR(-)	32U PV765778		
		8CO101MR	32U PV780777		
		9CO101MR	32U PV782764		
TK101MR	32U PV708668				
ART101MR	32U PV731672				
AT101MR	32U PV770725				
REC101MR	32U PV843662				
102MRR	32U PV740893				
1BN102MR(-)	32U PV744853	1BN102MR(-)	32U PV744853		
		2CO102MR	32U PV742851		
		3CO102MR	32U PV745885		
2BN102MR(-)	32U PV765932	2BN102MR(-)	32U PV765932		
		5CO102MR	32U PV780938		
		6CO102MR	32U PV777966		
3BN102MR(-)	32U PA762020				
TK102MR(-)	32U PV672936	TK102MR(-)	32U PV672936		
		2CO102TK	32U PV670930		
		3CO102TK	32U PV675934		
ART102MR(-)	32U PV731939	ART102MR(-)	32U PV731939		
		2BT102ART	32U PV720943		

23 April 1998

		3BT102ART	32U PV741924		
AT102MR(-)	32U PV725888	AT102MR(-)	32U PV722884		
		3BT102AT	32UPV713890		
REC102MR	32U PV842926				
104TR AA BNDY GRIDS	32U PV483730				
	32U PV582738				
	32U PV600706				
	32U PV583626				
	32U PV514620				
	32U PV465650				
1BN104TR	32U PV570645				
2BN104TR	32U PV515686				
3BN1046TR	32U PV568734				
MEC104TR	32U PV856613				
ART104TR	32U PV852747				
REC104TR	32U PV886360				
		1CO104M(-)	32U PV900870	1CO104M(-)	32U PV900870
		2CO104M(-)	32U PV915720	2CO104M(-)	32U PV915720
				REC104TR	32U PV886362
				1PL104M	32U PV902984
				6PL104M	32U PV889705
				3CO104M(-)	32U PV900588
				9PL104M	32U PV897503
10ARTRGT	32U PV690652				
1BN10ART	32U PV683596				
2BN10ART	32U PV610995	2BN10ART	32U PV610995		
		4BT10ART	32U PV613888		
		5BT10ART	32U PV616912		
		6BT10ART	32U PV595892		
10MRLBN	32U PV645650				
10RECBN	32U PV854727				
10ATBN	32U PV739764	10ATBN	32U PV739764		
		1BT10AT	32U PV747771		
		2BT10AT	32U PV740761		
		3BT10AT	32U PV722756		
1BT10AD	32U PV725468				
2BT10AD	32U PV734619				
3BT10AD	32U PV723737	3BT10AD	32U PV723737		
4BT10AD	32U PV734884	4BT10AD	32U PV734884		
1BT1AD	32U PV587567				
1BN1GUN	32U PV654692				
2BN1GUN	32U PV628612				
1BN1MRL	32U PV721625				

23 April 1998

2BN2MRL	32U PV630720				
ISQD1AVN	32U PV465868				
2SQD2AVN	32U PV465868				
UNITS HEADED SOUTH					
7CO101MR	32U PV600765	7CO101MR	32U PV600765		
1CO102MR	32U PV644842	1CO102MR	32U PV644842		
4CO102MR	32U PV675890	4CO102MR	32U PV675890		
10CO102TK (-) (2 PLTS)	32U PV620800	10CO102TR	32U PV620800		
1BT103AT	32U PV655857	1BT103AT	32U PV655857		
1BT102ART	32U PV666872	1BT102ART	32U PV666872		
TK CO (-) FOR					
AMBUSH AS SEEN # 35					
10CO102TK(-) 2 PLTS	32U PV771736	10CO102TK(-)	32U PV772736	10CO102TK(-)	32U PV772736
REINFORCED CO					
FOR ATK ON VILLAGE					
AS SEEN #35					
7CO101MR	32U PV721700	7CO101MR	32U PV721700	7CO101MR	32U PV721700
SSMs					
SSM1 (SS-21)	32U PV700500				
SSM2 (SS-21)	32U PV700800				
FLANK UNITS					
110MR	32U PV766208				
1BN110MR	32U PV769276				
2BN110MR	32U PV800212				
3BN110MR	32U PV797138				
TK110MR	32U PV715213				
AT110MR	32U PV774230				
ART110MR	32U PV750207				
REC110MR	32U PV900215				

**Battlefield Geometry**

STARTEX POS				
SERIES 1501 ED				
6-DMG 1:250,000			AS OF 11 JUL 97	
MAPS NM-32-9,12				
33-7,10				
EUROPAICHES				
DATUM 1950 (ED50)				
41D SOUTH BNDY	41D NORTH BNDY	2 X 3 BOUNDARY		
WEST TO EAST	WEST TO EAST	WEST TO EAST		
32U PV115365	32U PV115768	32U PV519540		
32U PV438354	32U PV320754	32U PV623536		
32U PV640343	32U PV500758	32U PV884529		
32U PV810349	32U PV745769	32U QV046508		
32U PV928317	32U PV915720	32U QV172518		
32U QV059311	32U QV071771	33U UQ043518		
33U TQ826308	33U TQ811788	33U UQ175506		
33U UQ044286	33U UQ078784	33U UQ353449		
33U UQ220178	33U UQ234764	33U UQ420430		
33U UQ388098	33U UQ530770			
33U UP610924	33U UQ648700	O/O		
33U UP800840	33U UQ807465	32U PV623526		
	33U UQ893394	32U PV606640		
	33UVQ062181	32U PV592768		
PL MEADE	PL SHERMAN	PL SHERIDAN	PL GRANT	
N TO S	N TO S	N TO S	N TO S	
32U PV444850	32U PV790854	33U TQ966870	33U UQ428818	
32U PV488760	32U PV800800	33U TQ944778	33U UQ428818	
32U PV500670	32U PV792718	33U TQ935698	33U UQ424642	
32U PV537574	32U PV789574	33U TQ910609	33U UQ418474	
32U PV483465	32U PV780440	33U TQ900507	33U UQ386270	
32U PV436355	32U PV807350	33U TQ845296	33U UQ378098	
32U PV430295	32U PV800300		33U UQ365049	
OBJ GOLD	OBJ SILVER	OBJ BRONZE	EA RAIN	EA THUNDER
32U PV652482	32U PV500750	32UPV244575	32U PV500760	32U PV617542
32U PV688438	32U PV562766	32UPV320608	32U PV542628	32U PV617716
32U PV480382	32U PV608720	32UPV316670	32U PV606640	32U PV767716
32U PV422400	32U PV557652	32UPV218700	32U PV590760	32U PV767542
32UPV415446	32U PV4946665	32UPV172637	32U PV500760	32U PV617542
32U PV652482	32U PV500750			
1 BDE AA	2 BDE AA	3 BDE AA	DIVARTY	
33U UQ642238	33U UQ435368	33U UQ444709	33U UQ536392	
33U UQ694258	33U UQ505389	33U UQ586720	33U UQ690412	

23 April 1998

33U UQ886160	33U UQ602240	33U UQ626415	33U UQ735296
33U UQ800100	33U UQ647118	33U UQ492415	33U UQ616250
33U UQ772120	33U UQ600030	33U UQ437492	33U UQ536392
33U UQ642238	33U UQ406190	33U UQ444709	
	33U UQ435368		
DISCOM AA	4TH BDE	DSA IRONHORSE	
33U UQ820078	33UUQ425080	33UTQ929318	
33U VQ002103	33UUQ461120	33UTQ960505	
33U VP024989	33UUP554978	33UUQ103508	
33U UP894889	33UUQ565029	33UUQ260302	
33U UP814898			
33U UQ820078			
PLAN TIGER BOUNDARY CHANGE			
32U QV141782 TO 32U QV021845 TO 32U PV597839 TO 32U PV488760			

**Routes**

		AS OF 111700 JUL 97						
ONLY UNITS WITH ROUTES MOVE. MERGED UNITS DO NOT SHOW ON DIV RCP BUT CAN SHOW ON THE APPROPRIATE								
BDE/BN/CO/PLT RCP WHEN DEAGGREGATED.								
STARTEX IS 102350 OCT 97								
OPFOR UNITS								
HEADED								
SOUTH. MOVT								
BEGINS								
STARTEX								
	STARTEX - ROUTE							SPEED
7CO101MR	32U PV600765	32U PV593753	32U PV600705	32U PV 610708	32U PV698664	32U PV721700	18 KPH	
1CO102MR	32U PV644842	32U PV593753	32U PV600705	32U PV 610708	32U PV698664	32U PV735700	18 KPH	
4CO102MR	32U PV675890	32U PV593753	32U PV600705	32U PV 610708	32U PV698664	32U PV735710	18 KPH	
10CO102TK	32U PV620800	32U PV593753	32U PV600705	32U PV 610708	32U PV698664	32U PV771736	18 KPH	
1BT103AT	32U PV655857	32U PV593753	32U PV600705	32U PV 610708	32U PV698664	32U PV710685	18 KPH	
1BT102ART	32U PV666872	32U PV593753	32U PV600705	32U PV 610708	32U PV698664	32U PV724680	18 KPH	
TK REGT								
MOVT BEGINS								
110035 OCT								
	START AT - ROUTE		SPEED					
1BN104TR	32U PV570645	32U PV670645	12 KPH					
2BN104TR	32U PV515686	32U PV615686	12 KPH					
3BN1046TR	32U PV568734	32U PV668734	12 KPH					
AMBUSH								
OPFOR TK								
CO MOVT								
BEGINS								
110145 OCT								
	START AT - ROUTE		SPEED					

10CO102TK	32UPV 771736	32U PV891762	12 KPH				
OPFOR CO ATKING VILLAGE. MOVT BEGINS 110110 OCT							
	START AT - ROUTE			SPEED			
7CO101MR	32U PV721700	32U PV 799775	32U PV898772	12 KPH			
	UNIT MERGED						
	INTO	STARTEX - ROUTE					
4ID TAC		33U TQ851520 - 20 KPH TO 32U QV038520 TO 32U PV988570 TO 32U PV955640 TO 32UPV954684					
IBDE		33U UQ205514 - 20 KPH TO 33U UQ080517 NORTH TO 33U 075591 NW ALONG HWY 85 TO 33U					
		UQ035599 TO 33U TQ934664 NORTH ON A93 TO 33U TQ932696 WEST TO 32U QV167693 TO 32U					
		QV135695 TO 32U QV055027 TO 32U PV980753					
1 RECON TRP		33U TQ910560 - 25 KPH TO 32U QV030555 TO 32U QV039651 TO 32U QV008709 TO 32U					
		PV986710 TO 32U PV964740 TO 32U PV932760. AT 11 0140 MOVE 30 KPH TO 32U PV 964740 TO					
		REFUEL. AT 110210 MOVE 20 KPH TO 32U PV826757.					
1-22IN (M)		33U UQ070517 - ORDER OF MARCH SCTS,B/1-22,1-22 TOC, MORT 1-22, B/3-66AR,A/1-22,D/1-22,					
		TNS 1-22 - 20 KPH TO 33U UQ006548 TO 33U TQ986577 TO 33U TQ937574 TO 33U TQ821550 TO					
		32U QV124616 TO 32U QV060668 TO 32U QV039651 TO 32U QV008709 TO 32U PV986710 TO 32U					
		PV964740					
A/299EN	1-22IN (M)	33U UQ070517 - AT 110045 BREAKS AWAY FROM 1-22IN AT 35 KPH AND MOVES TO 32U					
		PV932760 BY 110130					
B/1-22IN		AT 110155 BEGIN MOVE AT 20KPH FROM 33U PV946740 TO 33U PV922762					
B/3-66AR		AT 110155 BEGIN MOVE AT 20KPH FROM 33U PV946740 TO 32U PV914760.					
1/B/3-66AR		AT 110230 BEGIN MOVE AT 30 KPH FROM 32U PV914760 TO 32U PV896758					
3-66 AR		33U UQ292421 - ORDER OF MARCH SCTS, C/1-22,TOC 3-66,A/3-66,C/3-66,D/3-66, TNS 3-66 - 20					
		KPH TO 33U UQ172534 NW ALONG HWY 85 TO 33U UQ095590 TO 33U UQ035599					

		TO 33U					
		TQ934664 NORTH ON A93 TO 33U TQ932696 WEST TO 32U QV167693 TO 32U QV125695 TO 32U					
		QV055027 TO 32U PV980753					
A/1-44AD(-)		33U UQ250840 - 20 KPH TO 33U UQ080517 NORTH TO 33U 075591 NW ALONG HWY 85 TO 33U					
		UQ035599 TO 33U TQ934664 NORTH ON A93 TO 33U TQ932696 WEST TO 32U QV167693 TO 32U					
		QV135695 TO 32U QV055027 TO 32U PV983766					
A/2 CM	299EN(-)	33U UQ183478					
299EN(-)		33U UQ183478 - 20 KPH TO 33U UQ070517 TO 33U UQ006548 TO 33U TQ986577 TO 33U					
		TQ937574 TO 33U TQ821550 TO 32U QV124616 TO 32U QV060668 TO 32U QV039651 TO 32U					
		QV008709 TO 32U PV986710 TO 32U PV964740. AT 110245 MOVE TO 32U PV904730					
A/104 MI (ACT)		33U UQ185528 - 20 KPH TO 33U UQ080517 NORTH TO 33U 075591 NW ALONG HWY 85 TO 33U					
		UQ035599 TO 33U TQ934664 NORTH ON A93 TO 33U TQ932696 WEST TO 32U QV167693 TO 32U					
		QV135695 TO 32U QV055027 TO 32U PV982755					
1/4 MP CO	4 FSB(-)	33U UQ336304					
4 FSB(-)		33U UQ336304 - 20 KPH TO 33U UQ172534 NW ALONG HWY 85 TO 33U UQ095590 TO 33U					
		UQ035599 TO 33U TQ934664 NORTH ON A93 TO 33U TQ932696 WEST TO 32U QV167693 TO 32U					
		QV125695 TO 32U QV055027 TO 32U QV019755					
2 BDE		33U TQ822434 - 20 KPH TO 32U QV007427 - SLOW TO 5 KPH - MOVE TO 32U PV917435 - 5 KPH					
2 RECON TRP		32U PV986431 - 20 KPH TO 32U PV852404 - SLOW TO 5 KPH - MOVE TO 32U PV648395 - 5 KPH					
2-8 IN (M)		32U QV100425 - 20 KPH TO 32U PV848470 - SLOW TO 5 KPH - MOVE TO 32U PV754524 - 5KPH					
1-67 AR		32U QV108352 - 20 KPH TO 32U PV873383 - SLOW TO 5 KPH - MOVE TO 32U PV731390 - 5KPH					
3-67 AR		33U TQ948405 - 20 KPH TO 32U PV992408 - SLOW TO 5 KPH - MOVE TO 32U PV850439 - 5KPH					
3-16 FA (155MM)		32U QV999410 - 20KPH TO 32U PV995442 - SLOW TO 5 KPH - MOVE TO 32U PV825487 - 5 KPH					
214 FA BDE		33U TQ927484 - 20 KPH TO 32U QV010486 - SLOW TO 5 KPH - MOVE TO 32U PV915490 - 5 KPH					

23 April 1998

2-4 FA (MLRS)		33U TQ815369 - 20 KPH TO 32U QV001369 - SLOW TO 5 KPH - MOVE TO 32U PV826379 - 5KPH					
4/C/2-20 FA (Q37)	2-4 FA	33U TQ815369					
1-14 FA (MLRS)		33U TQ815455 - 20 KPH TO 32U QV002442 - SLOW TO 5 KPH - MOVE TO 32U PV818473 - 5 KPH					
5/C/2-20 FA (Q37)	1-14 FA	33U TQ815455					
5-3 FA (MLRS)		33U TQ959370 - 20 KPH TO 32U PV986393 - SLOW TO 5 KPH - MOVE TO 32U PV895406 - 5 KPH					
232 TAD Q37	5-3 FA	33U TQ959370					
C/2-365 AD	214 FA BDE	33U TQ927484					
B/2 CM	588 EN (-)	33U TQ910392					
B/1-44AD (-)	2 BDE	33U TQ822434					
588 EN (-)		33U TQ910392 - 20 KPH TO 32U PV873383 - SLOW TO 5 KPH - MOVE TO 32U PV810397 - 5 KPH					
B/104MI (ACT)	2 BDE	33U TQ822434					
2/4 MP CO	204 FSB	33U UQ107406					
204 FSB		33U UQ107406 - 20 KPH TO 32U TQ840400 - SLOW TO 5 KPH - MOVE TO 32U QV059417 - 5 KPH					
3 BDE		33U TQ908702 - 20 KPH TO 32U PV908669 - SLOW TO 5 KPH - MOVE TO 32U PV815664 - 5 KPH					
3 RECON TRP		32U PV976655 - 20 KPH TO 32U PV874646 - SLOW TO 5 KPH - MOVE TO 32U PV718624 - 5 KPH					
1-8 IN (M)		32U QV100653 - 20 KPH TO 32U PV873200 - SLOW TO 5 KPH - MOVE TO 32U PV761634 - 5 KPH					
1-68 AR		33U TQ923716 - 20 KPH TO 32U PV897685 - SLOW TO 5 KPH - MOVE TO 32U PV755670 - 5 KPH					
1-66 AR		32U QV169577 - 20 KPH TO 32U PV909588 - SLOW TO 5 KPH - MOVE TO 32U PV750584 - 5 KPH					
3-29 FA (155MM)		33U TQ947650 - 20 KPH TO 32U PV934648 - SLOW TO 5 KPH - MOVE TO 32U PV812637					
138 FA BDE )		33U UQ000639 - 20 KPH TO 32U PV995600 - SLOW TO 5 KPH - MOVE TO 32U PV807600 - 5 KPH					

23 April 1998

1-181 FA (MLRS)		33U TQ947575 - 20 KPH TO 32U PV994550 - SLOW TO 5 KPH - MOVE TO 32U PV808600 - 5 KPH				
4/231 TAD	1-181 FA	33U TQ947575				
1-623 FA (MLRS)		33U TQ973675 - 20 KPH TO 32U PV995658 - SLOW TO 5 KPH - MOVE TO 32U PV834648 - 5 KPH				
5/231 TAD	1-623 FA	33U TQ973675				
B/3-265 AD	138 FA BDE	33U UQ000639				
C/1-44AD	3 BDE	33U TQ908702				
C/2 CM BN	397EN (C)(M)	33U TQ956608				
397 EN (C) (M)		33U TQ956608 - 20 KPH TO 32U QV013620 - SLOW TO 5 KPH - MOVE TO 32U PV800778 - 5 KPH				
C/104 MI (ACT)	3 BDE	33U TQ908702				
3/4 MP CO	64 FSB	33U UQ137652				
64 FSB (-)		33U UQ137652 - 20 KPH TO 33U TQ809609 - SLOW TO 5 KPH - MOVE TO 32U QV115600 - 5 KPH				
4 BDE		33U UQ236570	NO MOVE			
A/1-12 IN (M)	4 BDE	33U UQ236570	NO MOVE			
1-4 AVN (ATK)		33U UQ182580	NO MOVE			
2-4 AVN (-)		33U UQ314535	NO MOVE			
1-6 CAV		33U UQ034530	NO MOVE			
3-6 CAV		33U UQ275225	NO MOVE			
2/20 FA (MLRS)		33U TQ845645 - 20 KPH TO 32U PV 968569 - SLOW TO 5 KPH - MOVE TO 32U PV857600 - 5 KPH				
I-10 CAV		33U UQ290170 - 20 KPH TO 33U UQ207688				
1/A/1-44 AD	I-10 CAV	33U UQ290170				
C/299 EN	I-10 CAV	33U UQ290170				

23 April 1998

DIV TRPS							
1-12 IN (M) TCF	DISCOM	33U UQ923000					
4ID ARTILLERY		33U UQ048593 - 20 KPH TO 32U QV040632 - SLOW TO 5 KPH - MOVE TO 32U PV926640 - 5 KPH					
4-42 FA (155MM)		33U UQ022544 - 20 KPH TO 32U QV041633 - SLOW TO 5 KPH - MOVE TO 32U PV897685 - 5 KPH					
3-18 FA (155MM)		33U TQ832491 - 20 KPH TO 32U PV932618 - SLOW TO 5 KPH - MOVE TO 32U PV668679 - 5KPH					
1-214FA (155MM)		33U TQ947558 - 20 KPH TO 32U PV987408 - SLOW TO 5 KPH - MOVE TO 32U PV846455 - 5 KPH					
1-44 AD (-)		33U UQ113467 - 20 KPH TO 33U TQ816470					
2 CM BN (-)	ENG GRP, 4ID	33U UQ245355					
ENG GRP, 4ID		33U UQ245355					
493 ENG GRP	ENG GRP, 4ID	33U UQ245355					
478 EN (C) (M)	ENG GRP, 4ID	33U UQ245355					
586 EN CO	ENG GRP, 4ID	33U UQ245355					
4 MP CO (-)	704 MSB	33U UP964978					
2175 MP CP	704 MSB	33U UP964978					
124 SIG BN (-)		33U UQ074370 - 20 KPH TO 32U QV182356 TO 32U QV064501					
DISCOM		33U UQ923000 - 20 KPH TO 33U UP 796854 TO 33U UQ394187					
704 MSB		33U UP964978 - 25 KPH TO 33U UP 796854 TO 33U UQ394187					
FLANK UNITS							
3ACR		33U UR560130 - 20 KPH TO 32U QA001145					
1/3ACR		33U UQ200890 - 20 KPH TO 32U PQV150889 TO 32U QV006974 TO 32U PV800974					
AIRCAV1		33U UQ009818 - TAKE OFF AT 102350 OCT FLY AT 100 KPH TO 32U QV029779 - SLOW TO					
		18 KPH - FLY TO 32U PV957789 TO 32U PV 900800 - SPEED UP TO 80 KPH FLY TO 33U					
		UQ460870 - LAND					

23 April 1998

AIRCAV2		33U UQ009818 - TAKE OFF AT 102350 OCT FLY AT 100 KPH TO 32U QV015821 - SLOW TO 18					
		KPH - FLY TO 32U PV939819 TO 32U PV 890854 - SPEED UP TO 80 KPH FLY TO 33U UQ460870					
		- LAND					
3BDE 22 ID (M)		33U TQ915275 - 20 KPH TO 32U QV190148 SLOW TO 5 KPH - MOVE TO 32U QV010110 TO 32U					
		PV937144					
1-39IN (M)		32U QV135266 - 20 KPH TO 32U PV966277 - SLOW TO 5 KPH - MOVE TO 32U PV781265					
1-13IN (M)		32U QV04218 - 20 KPH TO 32U QV010110 - SLOW TO 5 KPH - MOVE TO 32U PV802148					
1-29 FA		32U QV161175 - 20 KPH TO 32U QV010110 - SLOW TO 5 KPH - MOVE TO 32U PV900190					
OTHER UNITS							
SCENE 29 MAINT/ FUEL TRUCKS							
CONVOY 1							
		START AT - ROUTE					
		32U QV146546 - BEGIN MOVMT AT 110050 AT 20 KPH TO 32U QV124616 TO 32U QV060668					
		TO 32U QV039651 TO 32U QV008709 TO 32U PV986710 TO 32U PV964740					
SCENE 31 SSM							
LAUNCH SITES							
SSM 1(SS-21)		32U PV700500 - AT 110105 BEGIN MOVE AT 35KPH TO 32U PV300500					
SSM 2 (SS-21)		32U PV700800 - AT 110105 BEGIN MOVE AT 35 KPH TO 32U PV300500					

**Mil List**

COMBAT TIME	SCENE #	EVENT
102350 OCT 97	ALL	STARTEX - ALL 4 ID UNITS W/ROUTES, OPFOR UNITS MOVING SOUTH BEGIN MOVT, ACAV 1,2 TAKE OFF
110020 OCT 97	17	BDE SEES ACAV 1,2 TRACKS ON MCS
110035 OCT 97	35	OPFOR 102TR BEGINS MOVT.
110045 OCT 97	36	A/299 EN BREAK AWAY FROM 1-22IN AND MOVE TO 32U PV932760 BY 110130
110050 OCT 97	27,29	FUEL AND MAINTENEANCE CONVOY BEGINS MOVT
110105 OCT 97	31	OPFOR SSMs BEGIN MOVT
110110 OCT 97	44	7CO101MR BEGINS MOVT FROM 32U PV721700 TO 32U PV898772
110135 OCT 97	42,43,44,45	10CO102TR BEGINS MOVT FROM 32U PV771736 TO 32U PV891762
110155 OCT 97	39,40,41,46	B/1-22IN BEGINS MOVE FROM 32U PV 946740 TO 32U PV922762
110155 OCT 97	39,40,43,45	B/3-66AR BEGINS MOVE FROM 32U PV946740 TO 32U PV914760
110230 OCT 97	43-45	1/B/3-66AR BEGINS MOVE FROM 32U PV914760 TO 32U PV896758

23 April 1998

## Appendix C - Data Collection Sheets

CBS Experiment

### EXPERIMENT DATA COLLECTION SHEET

Experiment: CBS      Date: 8/12/97

Interface: RTM      Time: 15:30

Experiment ID: CBS/RTM/R8

(Format:Exp/Interface/Mission/Run)

### Objectives:

Use RT to communicate CBS red fixed wing missions flying over Patriot unit below 10k feet above ground level (AGL). RTM to communicate data to EADSIM and FAAD EO using TADIL-B report. AWACS sensor only.

### Description:

Fly two SU17 Fritters in CBS from Tel C to Pat C to Tel C. Mission data sent through CBS Master Interface to RTM, which converts it to a report and routes it to EADSIM (DIS) and FAAD EO (report) simultaneously, and from there to AMDWS.

Results:    Received    Not Received    Partially Received

Issues:

Locations:

CBS in Ft. Lewis

FAAD EO, EADSIM at WAIC

AMDWS at Ft. Leavenworth

23 April 1998

## EXPERIMENT DATA COLLECTION SHEET

Experiment: CBS Date: 8/12/97 (end)

Interface: RTM Time: 16:00

Experiment ID: CBS/RTM/B8

(Format:Exp/Interface/Mission/Run)

## Objectives:

Use RT to communicate CBS blue fixed wing missions flying over enemy ADA unit below 10k feet above ground level (AGL). RTM to communicate data to EADSIM and FAAD EO using TADIL-B report. AWACS sensor only.

## Description:

Fly two HIP in CBS from Tel D to Patriot D to Tel D. Mission data sent through CBS Master Interface to RTM, which converts it to a F-3 report and routes it to EADSIM (DIS) and FAAD EO simultaneously, and from there to AMDWS.

Results: Received Not Received Partially Received

## Issues:

1. WAIC system crashed at 10:00-10:25.
2. Ft. Leavenworth at lunch; no one monitoring AMDWS for R2A/B2A-no confirmed track data from FAAD to AMDWS (see B2A).

## Locations:

CBS in Ft. Lewis

FAAD EO, EADSIM at WAIC

AMDWS at Ft. Leavenworth

23 April 1998

## EXPERIMENT DATA COLLECTION SHEET

Experiment: CBS      Date: 8/12/97

Interface: RTM      Time: 15:00

Experiment ID: CBS/RTM/B2

(Format:Exp/Interface/Mission/Run)

### Objectives:

Use RT to communicate CBS blue rotary wing missions flying over red ADA unit below 10k feet above ground level (AGL). RTM to communicate data to EADSIM through DIS protocols and FAAD EO using TADIL-B M2/M82 Track Message report. Only AWACS sensors used.

\*NOTE: FDL 3 extended reports are needed for above 10k feet; FAAD EO does not read extended messages; must use TADIL-B instead, due to AWACS sensors.

### Description:

Fly two AH-64 in CBS from Hawk 2 to Tel Alpha and reverse direction. Mission data sent through CBS Master Interface to RTM, which converts it to a F-3 report and routes it to EADSIM (DIS) and FAAD EO simultaneously, and from there to AMDWS.

Results:    Received    Not Received    Partially Received

### Issues:

1. See R1 mission.

### Locations:

CBS in Ft. Lewis

FAAD EO, EADSIM at WAIC

AMDWS at Ft. Leavenworth

23 April 1998

## EXPERIMENT DATA COLLECTION SHEET

Experiment: CBS      Date: 8/12/97

Interface: RTM      Time: 15:25

Experiment ID: CBS/RTM/R2/1

(Format:Exp/Interface/Mission/Run)

**Objectives:**

Use RT to communicate CBS red rotary wing missions flying over Hawk unit below 10k feet above ground level (AGL). RTM to communicate data to EADSIM and FAAD EO using TADIL-B M2/M82 report. Only AWACS sensors used.

**Description:**

Fly two HIP in CBS from Tel B to TAC B to Tel B. Mission data sent through CBS Master Interface to RTM, which converts it to a TADIL-B report and routes it to EADSIM (DIS) and FAAD EO simultaneously, and from there to CRTD and/or AMDWS.

**Results:**    Received    Not Received    Partially Received**Issues:**

1. FAAD EO not talking to CRTD using the F-3 reports.

**Locations:**

CBS in Ft. Lewis

FAAD EO, EADSIM at WAIC

CRTD and AMDWS at Ft. Leavenworth

23 April 1998

## EXPERIMENT DATA COLLECTION SHEET

Experiment: CBS      Date: 8/12/97      (end)

Interface: RTM      Time: 16:00

Experiment ID: CBS/RTM/B8

(Format:Exp/Interface/Mission/Run)

### Objectives:

Use RT to communicate CBS blue fixed wing missions flying over enemy ADA unit below 10k feet above ground level (AGL). RTM to communicate data to EADSIM and FAAD EO using TADIL-B report. AWACS sensor only.

### Description:

Fly two F15E in CBS from Hawk 2 to Tel B to Hawk 2. Mission data sent through CBS Master Interface to RTM, which converts it to report and routes it to EADSIM (DIS) and FAAD EO (report) simultaneously, and from there to CRTD and to AMDWS.

Results:    Received    Not Received    Partially Received

### Issues:

#### Locations:

CBS in Ft. Lewis

FAAD EO, EADSIM at WAIC

CRTD and AMDWS at Ft. Leavenworth

23 April 1998

**EXPERIMENT DATA COLLECTION SHEET**

Experiment: CBS      Date: 8/13/97 (start)

Interface: RTM      Time: 09:30-10:30

Experiment ID: CBS/RTM/R2A/1

(Format:Exp/Interface/Mission/Run)

**Objectives:**

Use RT to communicate CBS red rotary wing missions flying over Patriot below 10k feet above ground level (AGL). RTM to communicate data to EADSIM and FAAD EO using TADIL-B report. AWACS sensor only.

**Description:**

Fly two HIP in CBS from Tel D to Patriot D to Tel D. Mission data sent through CBS Master Interface to RTM, which converts it to a report for the FAAD EO and routes it to EADSIM (DIS), and from there to AMDWS.

**Results:**    Received    Not Received    Partially Received**Issues:**

1. WAIC system crashed at 10:00-10:25.
2. Ft. Leavenworth at lunch; no one monitoring AMDWS for R2A/B2A-no confirmed track data from FAAD to AMDWS (see B2A).

**Locations:**

CBS in Ft. Lewis

FAAD EO, EADSIM at WAIC

AMDWS at Ft. Leavenworth

23 April 1998

## EXPERIMENT DATA COLLECTION SHEET

Experiment: CBS      Date: 8/13/97

Interface: RTM      Time: 10:30

Experiment ID: CBS/RTM/B2A/1

(Format:Exp/Interface/Mission/Run)

### Objectives:

Use RT to communicate CBS blue rotary wing missions flying over enemy ADA below 10k feet above ground level (AGL). RTM to communicate data to EADSIM and FAAD EO using TADIL-B report. AWACS sensor only.

### Description:

Fly two AH-64 in CBS from Hawk 1 to Tel B to Hawk 1. Mission data sent through CBS Master Interface to RTM, which converts it to a report for FAAD EO and routes it to EADSIM (DIS) simultaneously, and from there to AMDWS.

Results:    Received    Not Received    Partially Received

### Issues:

1. Old run data (icons) interfered with tracking mission data, making AH-64 hard to see due to clutter of logged data from 8/12.
2. AH-64 classified as fixed wing aircraft due to speed ranges overlapping. AH-64 flying at 145 knots per hour. 82 meters/second is acceptable on FADD; 74 meters/second is acceptable in EADSIM.
3. Ft. Leavenworth at lunch; no one monitoring AMDWS for R2A/B2A-no confirmed track data from FAAD to AMDWS (see R2A).

### Locations:

CBS in Ft. Lewis

FAAD EO, EADSIM at WAIC

AMDWS at Ft. Leavenworth

## EXPERIMENT DATA COLLECTION SHEET

Experiment: CBS      Date: 8/13/97

Interface: RTM      Time: 11:12

Experiment ID: CBS/RTM/R14

(Format:Exp/Interface/Mission/Run)

### Objectives:

Use RT to communicate CBS red fixed wing missions flying over Hawk unit starting below 10k feet above ground level (AGL) and going above 10k feet AGL. RTM to communicate data to EADSIM and FAAD EO using TADIL-B report. AWACS sensor only.

### Description:

Fly two SU17 Fritters in CBS from Tel C to Pat Alpha to Hawk 2 to C43, starting below 10k feet and ascending above 10k feet. Mission data sent through CBS Master Interface to RTM, which converts it to a FAAD EO report and routes it to EADSIM (DIS) simultaneously, and from there to AMDWS.

Results:    Received    Not Received    Partially Received

### Issues:

1. Fritters were not going above 10k feet: order correlation error. CBS operators were assuming top altitude of 10k feet AGL; WAIC/EADSIM were assuming 10k meters AGL.
2. F3 air tracks being sent by RTM to FAAD EO below 10k feet. Do not have tactical systems to send TADIL-B, which is being used above 10k feet (TBM) directly from RTM to AMDWS.

### Locations:

CBS in Ft. Lewis

FAAD EO, EADSIM at WAIC

AMDWS at Ft. Leavenworth

## EXPERIMENT DATA COLLECTION SHEET

Experiment: CBS      Date: 8/13/97      (end)

Interface: RTM      Time: 15:22

Experiment ID: CBS/RTM/B14

(Format:Exp/Interface/Mission/Run)

### Objectives:

Use RT to communicate CBS blue fixed wing missions flying over red ADA unit starting low, ascending high, and descending low again. RTM to communicate data to EADSIM and FAAD EO. AWACS sensor only.

### Description:

Fly two F15E in CBS starting at 5k feet at AB1, ascending to 35k feet at Hawk 1 through Tel B and Tel D, and descending to 5k feet from Tel D to AB1. Mission data sent through CBS Master Interface to RTM, which converts it to FAAD EO report and routes it to EADSIM (DIS) and FAAD EO simultaneously, and from there to AMDWS.

Results:    Received    Not Received    Partially Received

### Issues:

1. Same problem as R14A

### Locations:

CBS in Ft. Lewis

FAAD EO, EADSIM at WAIC

AMDWS at Ft. Leavenworth

23 April 1998

## EXPERIMENT DATA COLLECTION SHEET

Experiment: CBS      Date: 8/14/97 (start)

Interface: RTM      Time: 09:30-10:15

Experiment ID: CBS/RTM/R14C

(Format:Exp/Interface/Mission/Run)

## Objectives:

Use RT to communicate CBS red fixed wing missions over red territory (Tels) starting low, ascending high, and descending low again. RTM to communicate data to EADSIM and FAAD EO using TADIL-B report. Route over red territory so that aircraft are not shot down by EADSIM. This is needed for the CLCGF experiment. AWACS sensor only.

## Description:

Fly five SU17 in CBS starting at 2k feet at AB to Tel B, ascending to 35k feet from Tel B to Tel C, and descending to 2k feet from Tel C to AB. Mission data sent through CBS Master Interface to RTM, which converts it to a FAAD EO report and routes it to EADSIM (DIS) simultaneously, and from there to AMDWS. Altitude check on FAAD EO and AMDWS to resolve altitude correlation problem.

Results:    Received    Not Received    Partially Received

## Issues:

1. Aircraft staying at 2k feet after Tel B; order entered wrong. CBS working correctly. Order entered as: AB--2000--B--2000--C--35000--B--2000--AB. Tracks OK.

## Locations:

CBS in Ft. Lewis

FAAD EO, EADSIM at WAIC

AMDWS at Ft. Leavenworth

23 April 1998

## EXPERIMENT DATA COLLECTION SHEET

Experiment: CBS      Date: 8/14/97

Interface: RTM      Time: NA

Experiment ID: CBS/RTM/B14A

(Format:Exp/Interface/Mission/Run)

**Objectives:**

Use RT to communicate CBS blue fixed wing missions over blue territory (Hawk units) starting low, ascending high, and going low again. RTM to communicate data to EADSIM and FAAD EO using TADIL-B reports.

**Description:**

Fly one F15E in CBS starting at 10k feet from AB1 to Hawk 1, at 40k feet from Hawk1 to Hawk 2, and at 10k feet from Hawk 2 to AB1. Mission data sent through CBS Master Interface to RTM, which converts it to a FAAD EO report and routes it to EADSIM (DIS) simultaneously, and from there to AMDWS. Altitude check on FAAD EO and AMDWS to resolve altitude correlation problem.

**Results:**    Received    Not Received    Partially Received**Issues:**

1. AWACS ran out of fuel in EADSIM during mission-no data capture. Repeat.

**Locations:**

CBS in Ft. Lewis

FAAD EO, EADSIM at WAIC

AMDWS at Ft. Leavenworth

23 April 1998

## EXPERIMENT DATA COLLECTION SHEET

Experiment: CBS Date: 8/14/97

Interface: RTM Time: 10:15

Experiment ID: CBS/RTM/B14B

(Format:Exp/Interface/Mission/Run)

## Objectives:

Use RT to communicate CBS blue fixed wing missions over blue territory (Hawk units) starting low, ascending high, and going low again. RTM to communicate data to EADSIM and FAAD EO using TADIL-B report. AWACS sensor only.

## Description:

Fly one F15E in CBS starting at 15k feet from AB1 to Hawk 1, at 35k feet from Hawk1 to Hawk 2, and at 15k feet from Hawk 2 to AB1. Mission data sent through CBS Master Interface to RTM, which converts it to a report for FAAD EO and routes it to EADSIM simultaneously, and from there to AMDWS. Altitude check on FAAD EO and AMDWS to resolve altitude correlation problem.

Results: Received Not Received Partially Received

## Issues:

1. Same as B14A: AWACS ran out of fuel in EADSIM during mission-no data capture. Repeat.

## Locations:

CBS in Ft. Lewis

FAAD EO, EADSIM at WAIC

AMDWS at Ft. Leavenworth

23 April 1998

## EXPERIMENT DATA COLLECTION SHEET

Experiment: CBS Date: 8/14/97

Interface: RTM Time: NA

Experiment ID: CBS/RTM/R14D

(Format:Exp/Interface/Mission/Run)

## Objectives:

Use RT to communicate CBS red fixed wing missions starting low, ascending high, and descending low again. RTM to communicate data to EADSIM and FAAD EO using TADIL-B report.

## Description:

Fly two SU17 in CBS starting at 2k feet from Big A to B, at 35k from B to Tel E, and at 2k from Tel E to Big A.. Mission data sent through CBS Master Interface to RTM, which converts it to a FAAD EO report and routes it to EADSIM (DIS simultaneously, and from there to AMDWS. Altitude check on FAAD EO and AMDWS to resolve altitude correlation problem.

Results: Received Not Received Partially Received

## Issues:

1. Same as B14A: AWACS ran out of fuel in EADSIM during mission-no data capture. Repeat.

## Locations:

CBS in Ft. Lewis

FAAD EO, EADSIM at WAIC

AMDWS at Ft. Leavenworth

23 April 1998

Experiment: CBS      Date: 8/14/97  
Interface: MCS SSM    Time: 09:45-11:30  
Experiment ID: CBS/SSM  
(Format:Exp/Interface/Mission)

### Objectives:

Use SSM to translate position/location data for eight maneuver units from CBS to MCS/P and compare location in simulation with location on MCS/P box. Use this data for MRCI runs of the same type to compare results.

### Description:

Track the locations of eight units through seven fifteen minute location updates in CBS. The CBS units tracked include: 3/66ARM, B/3-66ARM, A/1-22MECH, B/1-22MECH, C/1-22MECH, 2BDE4, 3BDE4, and 1-10CAV.

At start time 1 (020221Z, game time), 6 units were moving and 2 were defending. By time 7, the end of the game (0203537Z, game time), all units were stopped.

All eight units tracked appropriately from CBS through SSM to MCS/P. Exact grid coordinates were compared between CBS and MCS/P; no errors observed.

Results:    Received    Not Received    Partially Received

All units tracked correctly.

### Issues:

### Locations:

CBS in Ft. Lewis

MCS/P in Ft. Leavenworth

23 April 1998

Experiment: CBS      Date: 8/15/97  
Interface: MRCI      Time: 09:45-13:00  
Experiment ID: CBS/MRCI  
(Format:Exp/Interface/Mission)

### Objectives:

Use MRCI to translate position/location data for eight maneuver units from CBS to MCS/P and compare location in simulation with location on MCS/P box. Use SSM data to compare with MRCI results.

### Description:

Track the locations of eight units through seven fifteen minute location updates in CBS. The CBS units tracked include: 3/66ARM, B/3-66ARM, A/1-22MECH, B/1-22MECH, C/1-22MECH, 2BDE4, 3BDE4, and 1-10CAV.

At start time 1 (020221Z, game time), 6 units were moving and 2 were defending. By time 7, the end of the game (0203537Z, game time), all units were stopped.

All eight units tracked appropriately from CBS through SSM to MCS/P. Exact grid coordinates were compared between CBS and MCS/P; no errors observed.

### Results:    Received    Not Received    Partially Received

Units received as per SSM, with one exception: see issue 2 below.

### Issues:

1. The RTI machine wedged at one point because someone not involved in the experiment used it for unrelated activities-process had to be restarted.
2. The Easting location on the MCS/P box had a rounding down error. For example, D/1-22MECH showed a position of "32UQV101635" in CBS but a position of "32UQV101634" on the MCS/P box. This was consistent and is assumed to be an easily fixed algorithmic rounding error.
3. MRCI staff were able to quickly develop a capability to request unit status data and display it

### Locations:

CBS in Ft. Lewis

MCS/P in Ft. Lewis

23 April 1998

## CLCGF Experiment

Experiment: CLGCF Date: 27 Aug 97

Interface: TSIU Time: 15:30

Experiment ID: CLCGF / TSIU / F-59 through F-63

(Format: Experiment / Interface / Mission)

### Objectives:

Send Division Level Threat Reports from EADSIM through TSIU to AMDWS (FAADC21)

### Description:

F-59: TBM Pairing - screen displays line connecting Launch Point, TBM position and Impact Point

F-60: TBM Special Point - screen displays Launch Point and Impact Point marked with an X and a red TBM Warning light

F-61: TBM General Amp - screen displays an ellipse containing the Launch point and Impact Point and Amplification Window

F-62: TBM Position - screen displays missile position in reference to Launch Point and Impact Point

F-63: TBM Position Amp - screen displays TBM Amplification Window

Results: Received Not Received Partially Received

### Issues:

- 1) Unclassified data could not be shown in an unclassified environment. TIBS and TRAP data would be available in a classified setting.
- 2) Logged data allows replaying of scenario and linkage for demonstrations.
- 3) AMDWS problem with TBM warning light. F-60 message should trigger a red warning light
- 4) Amount of data for AMDWS screen display caused a restart of AMDWS.
- 5) The F-60 issue shows the same logged sim data should be used for regression testing that was used for testing earlier ATCCS systems to ensure accurate handling of data.

Experiment: CLGCF Date: 27 Aug 97  
Interface: TSIU Time: 16:00  
Experiment ID: CLCGF / TSIU / F-3  
(Format: Experiment / Interface / Mission)

**Objectives:**

Send F-3 Track Report from EADSIM through TSIU to FAAD EO

**Description:**

Report should display Hostile (Red) and Friendly (Blue) Forces. Air Traffic shows Hostile or Friendly aircraft with Heading, Altitude and Speed. This information is displayed for the selected Cone of Interest only.

Results: Received Not Received Partially Received

**EXPERIMENT DATA COLLECTION SHEET**

Experiment: CLCGF Date: 8/28/97  
Interface: TSIU Time: 13:30  
Experiment ID: MCS/USMTF/S507  
(Format:Exp/Interface/Mission/Run)

**Objectives:**

Send USMTF S507 messages from Eagle to MCS at Division, Brigade and Battalion level.

**Description:**

Results: Received Not Received Partially Received

**Issues:**

- 1) A 1-22 Mech message should not be displayed.
- 2) Check 1-10 Cav reporting at Brigade level.
- 3) Check 1-66 AR at Brigade level.
- 4) Check 4 ID, A-1-66 AR, B-1-66 AR, B-3-66 AR, C-1-66AR, D-1-66, HHC-1, HHC-1 Bde, HHC-3-66 AR icons

**Data Collectors:**

Scott Newman

**Locations:**

AE4 Lab, LM Info Systems, Orlando, FL

## EXPERIMENT DATA COLLECTION SHEET

Experiment: CLCGF Date: 8/28/97

Interface: TSIU Time: 14:45

Experiment ID: ASAS

(Format:Exp/Interface/Mission/Run)

### Objectives:

Receive Division Level ASAS reports

### Description:

Results: Received    Not Received    Partially Received

Issues:

### Data Collectors:

Scott Newman

### Locations:

AE4 Lab, LM Info Systems, Orlando, FL

23 April 1998

## EXPERIMENT DATA COLLECTION SHEETS

Experiment: CLCGF Date: 8/29/97

Interface: TSIU Time: 9:00

Experiment ID: CLCGF/TSIU/Appliqué/Move

(Format:Exp/Interface/Mission/Run)

**Objectives:**

Use TSIU to send movement update message from ModSAF to Company Appliqué.

**Description:**

TSIU converts CCSIL movement messages from ModSAF to VMF messages interpretable by Appliqué. These messages are sent every update period and move the unit icons on Appliqué to reflect this change in position.

**Results:**    Received    Not Received    Partially Received**Issues:**

1. Enemy positions are updated from spot reports thereby creating duplicate reports. Result:  
This problem is currently being worked to filter out the same update message.

**Locations:**

Appliqué, TSIU, ModSAF: OSF (Orlando)

23 April 1998

## EXPERIMENT DATA COLLECTION SHEETS

Experiment: CLCGF Date:8/29/97

Interface: TSIU Time:10:00

Experiment ID:CLCGF/TSIU/Appliqué/Call4Fire

(Format:Exp/Interface/Mission/Run)

**Objectives:**

Use TSIU to send Call for Fire message to ModSAF from Company Appliqué.

**Description:**

TSIU converts VMF Call for Fire message from Appliqué to CCSIL message interpretable by ModSAF.

**Results:** Received Not Received Partially Received**Issues:**

1. ModSAF does not support Call for Fire messages so we were only able to verify that the TSIU received the VMF message from Appliqué and formatted a CCSIL message to send to ModSAF. Result: Need to modify ModSAF to complete test.

**Locations:**

Appliqué, TSIU, ModSAF: OSF (Orlando)

## EXPERIMENT DATA COLLECTION SHEETS

Experiment: CLCGF Date:8/29/97

Interface: TSIU Time:9:30

Experiment ID:CLCGF/TSIU/Appliqué/NBC

(Format:Exp/Interface/Mission/Run)

### Objectives:

Use TSIU to send NBC report from PEGEM to Company Appliqué.

### Description:

TSIU converts NBC report from PEGEM to VMF message interpretable by Appliqué. This report originates from a sensor on the tank (PEGEM), is sent through EADSIM to the TSIU and then to Appliqué.

Results: Received Not Received Partially Received

### Issues:

None.

### Locations:

Appliqué, TSIU, EADSIM: OSF (Orlando)

23 April 1998

Experiment: CLCGF Date: 27 Aug 97

Interface: TSIU Time: 16:00

Experiment ID: CLCGF / TSIU / F-3

(Format: Experiment / Interface / Mission)

### Objectives:

Send F-3 Track Report from EADSIM through TSIU to FAAD EO

### Description:

Report should display Hostile (Red) and Friendly (Blue) Forces. Air Traffic shows Hostile or Friendly aircraft with Heading, Altitude and Speed. This information is displayed for the selected Cone of Interest only.

### Issues:

### Results:

F-3 Report Received

23 April 1998

## EXPERIMENT DATA COLLECTION SHEET

Experiment: CLCGF      Date: 8/27/97

C2 System Tested: MSAC      Time: 10:00

Experiment ID: CLCGF/MSAC/1

(Format:Exp/Interface/Mission/Run)

**Objectives:**

Run ModSAF Entity State (ES) PDU's to Mystech's casualty simulator, providing S302 free text USMTF casualty information to MSAC as a status update.

**Description:**

Surgical status report for MSAC is colored green, amber, black depending on number of patients to be serviced. Number can be set by user. For experiment, no patients= green; 1 patient=amber; 2 patients=black. Update rate can be set; used 15-30 second updates for experiment. Evacuation data stays green until maximum is achieved. Used logged ModSAF ES data for experiment, which contains unit damage.

Indicator icons turned green, amber, and black under stated condition.

**Results:**    Received    Not Received    Partially Received

**Issues:**

1. Since simulation traffic and tactical messages were sent on the same network, the two had to be bridged. This combined data stream negatively impacts the C2 boxes. Need a 2 Ethernet card solution to keep the 2 data streams separated.
2. Patients do not leave beds/OR; need to modify code to let patients leave.

**Locations:**

MSAC, ModSAF/logged ES messages, and MCS in Orlando.

23 April 1998

## EXPERIMENT DATA COLLECTION SHEET

Experiment: CLCGF      Date: 8/26/97

C2 System Tested: MSAC      Time: 10:00

Experiment ID: CLCGF/MSAC/Demo

(Format:Exp/Interface/Mission/Run)

## Objectives:

1. Use Medical Situation Awareness and Control (MSAC) to participate in Army simulation exercise.
2. Develop casualty generator for exercise.
3. Participate in exercise from remote location.

## Description:

First run was a MSAC demonstration.

MSAC was developed on the MCS beta version and is Netscape-based with Java scripts, running on Sun, Mac and PC platforms. The intent is to test MSAC medical C2 within a simulation environment at Brigade level and below. MSAC uses a common database to provide a common picture. It retrieves overlay data from ASAS and MCS/P using USMTF messages.

Four of ten medical functions have been developed in MSAC and were demonstrated successfully: medical C2, evacuation, logistics and blood, hospitalization.

The six remaining medical functions will be developed in the future, including: area medical support, combat stress, dental, lab, preventive medicine, veterinary medicine.

Results:    Received    Not Received    Partially Received

Issues:

Locations:

MSAC, ModSAF, and MCS in Orlando.

23 April 1998

## EXPERIMENT DATA COLLECTION SHEET

Experiment: CLCGF      Date: 8/27/97

C2 System Tested: MSAC      Time: 9:00

Experiment ID: CLCGF/MSAC/2

(Format:Exp/Interface/Mission/Run)

**Objectives:**

Observe MSAC long haul capability.

**Description:**

Create ModSAF Entity State (ES) PDU's in Orlando, send to MSAC long distance for parsing, observe on common database in Orlando.

Long haul test was configured as an ISDN connection between Orlando (local) and Manasses (remote) machines via modem connection. The local machine processed the DIS entity state PDU's and generated local casualty statistics. These stats were then sent to the remote machine via FTP. The remote machine parsed the casualty data and updated the remote database files. To prove visibility to the remote machine data structures, the local machine started Netscape. The local machine http pointed to Manassas and displayed the remote database information locally.

Demo successful long haul.

Results:    Received    Not Received    Partially Received

Issues:

Locations:

MSAC, ModSAF/logged ES messages, and MCS. Orlando (local) and Manassas (remote).

23 April 1998

## EXPERIMENT DATA COLLECTION SHEETS

Experiment: CLCGF Date:9/3/97

Interface: VHMS Time:10:00

Experiment ID:CLCGF/VHMS

(Format:Exp/Interface/Mission/Run)

**Objectives:**

Monitor vehicle status and update Appliqué and CSSCS.

**Description:**

Vehicle onboard diagnostics sends status of vehicle to VHMS. VHMS then updates Appliqué and CSSCS with information about various vehicle components. VHMS also monitors simulated vehicles from ModSAF. VHMS can be used to predict component failures based on stored statistical data.

**Results:** Received Not Received XPartially Received**Issues:**

1. Used simulated data from "live vehicle" to remain within cost and time constraints of test.  
Result: Run test again with live vehicle.
2. VHMS updated information slowly on screen. Result: VHMS currently runs on a 486 but is being ported to a Pentium for future testing.
3. VHMS only updates information on single vehicles. Result: VHMS plans on monitoring status of platoons and higher echelons in future releases.

**Data Collectors:**

Colleen Finnerty

**Locations:**

Appliqué, VHMS: OSF (Orlando)

## EXPERIMENT DATA COLLECTION SHEETS

Experiment: CLCGF Date:9/3/97

Interface: VHMS Time:10:00

Experiment ID:CLCGF/VHMS

(Format:Exp/Interface/Mission/Run)

### Objectives:

Monitor vehicle status and update Appliqué and CSSCS.

### Description:

Vehicle onboard diagnostics sends status of vehicle to VHMS. VHMS then updates Appliqué and CSSCS with information about various vehicle components. VHMS also monitors simulated vehicles from ModSAF. VHMS can be used to predict component failures based on stored statistical data.

Questions:

Results: Received Not Received XPartially Received

### Issues:

1. Used simulated data from "live vehicle" to remain within cost and time constraints of test.  
Result: Run test again with live vehicle.
2. VHMS updated information slowly on screen. Result: VHMS currently runs on a 486 but is being ported to a Pentium for future testing.
3. VHMS only updates information on single vehicles. Result: VHMS plans on monitoring status of platoons and higher echelons in future releases.

### Data Collectors:

Colleen Finnerty

### Locations:

Appliqué, VHMS: OSF (Orlando)

23 April 1998

## EXPERIMENT DATA COLLECTION SHEET

Experiment: CLCGF Date: 9/4/97

Interface: Appliqué Time: 14:30

Experiment ID:

(Format:Exp/Interface/Mission/Run)

### Objectives:

Show communication between units at the Battalion Level

### Description:

Grafenfels Database Area is used for this test. Display was at the Battalion level with the 3-66 D and 1-22 companies shown.

Results: Received Not Received Partially Received

### Issues:

### Data Collectors:

Scott Newman

### Locations:

AE4 Lab, LM Info Systems, Orlando, FL

23 April 1998

## DBBL Experiment

## EXPERIMENT DATA COLLECTION SHEET

Experiment: DBBL            Date: 9/4/97  
Interface: Land Warrior    Time: 12:30-15:00  
Experiment ID: DBBL/LW/2  
(Format:Exp/Interface/Run)

**Objectives:**

Populate the LW-IHAS view with the entities involved in the exercise, using VMF position messages from Appliqué.

**Description:**

Run the mission, using ModSAF, and the manned Sim's on the DIS network. Send the traffic through the Appliqué Interface, to Appliqué, populating that screen. The same entities should be passed to the LW system, from Appliqué, in VMF messages.

**Results:**    Received    Not Received    Partially Received

**Issues:**

1. Machines not always stable, prone to crashes. LW system, when receiving messages about entities not in their host file, will crash. Appliqué unstable and crashes can result at any time. Appliqué and LW system VMF messages off by 2 bytes. Fix: LW messages were made to fill in the 8 bits with null characters when passing to appliqué. When returning the other way, LW dropped the last 8 bits from the message.

**Locations:**

DBBL at Ft. Benning

23 April 1998

## EXPERIMENT DATA COLLECTION SHEET

Experiment: DBBL Date: 9/4/97  
Interface: LW System Time: 15:00-16:00  
Experiment ID: DBBL/LW/3  
(Format:Exp/Interface/Run)

**Objectives:**

Pass report messages between LW and Appliqué.

**Description:**

Appliqué and LW users to create reports, and send them back and forth between the two systems.

Results: Received Not Received Partially Received

**Issues:**

1. Land Warrior able to send all reports to Appliqué. Byte problem still handled in Ex ID DBBL/LW/1. Appliqué only able to send Free Text messages to LW system. No other messages received correctly. Appliqué unable to generate spot reports on the MOUT terrain database. While trying to generate a spot report, Appliqué produces the error '16S not in the FA map'. Even when Appliqué generates the position itself, this error occurs. It is believed LW would be able to handle spot reports, but due to this problem, not able to test.

**Locations:**

DBBL in Ft. Benning

23 April 1998

## EXPERIMENT DATA COLLECTION SHEET

Experiment: DBBL Date: 9/4/97

Interface: LW Time: 14:00-17:00

Experiment ID: DBBL/LW/1

(Format:Exp/Interface /Run)

**Objectives:**

Bring all entities up on Grafenfels database, and have them show on both Appliqué and LW system, as well as Sim's and ModSAF.

**Description:**

All manned Sim's and ModSAF entities are brought up on Grafenfels database. Entities are connected via the DIS net to the OSF, where more entities are placed. All entities from both sites should show on all systems.

**Results:** Received Not Received Partially Received**Issues:**

1. LW system not able to show all entities at this time. This was fixed the following week. This experiment was postponed several times. The ARC (Army Research Center), in charge of the DIS hub, decided to update its hardware without making anyone aware first. This could have been avoided by centralizing all equipment in the experiment, or by the use of a direct connection via internet line, for example a T1 line.

**Locations:**

OSF at Orlando

DBBL at Ft. Benning

23 April 1998

## EXPERIMENT DATA COLLECTION SHEET

Experiment: DBBL Date: 9/4/97  
Interface: SVS/ODT Time: 08:30-11:30  
Experiment ID: DBBL/SVS/ODT/1  
(Format:Exp/Interface/Run)

**Objectives:**

Put all players out on MOUT Database, and test database correlation between all systems, including manned Sim's.

**Description:**

The mission was run, using all the entities, generated from all the systems. All Sim's should be able to see all the entities in the mission, from ModSAF generated, to other manned Sim's. Systems were brought up with Grafenfels and MOUT database and missions were run.

Results: Received Not Received Partially Received

**Issues:**

There were no problems found with Grafenfels database correlation with any of the systems. However, a problem existed with the MOUT database on the M2 manned Sim. Database for the M2 did not correlate with the others. When ground clamping was turned on, other entities floated in the air. When trying to view the M2 from the other manned Sim's (SVS/ODT), M2 was unable to be seen for it was under the ground. It was determined that there existed a 3 meter difference between the terrains, and only if this difference was lower in spots would you be able to see even part of the M2. But even then it was buried in the ground. A stealth was used to determine where the M2 was positioned, when it could not be seen. Fix: MOUT database for the M2 needs to be further developed, or hardware should be updated on the M2 mock-up. It was suggested the M2's current hardware configuration was the reason it could not show the database correctly.

**Locations:**

DBBL at Ft. Benning

# Appendix D - AE4 Component Architecture Diagrams

## CBS ARCHITECTURE

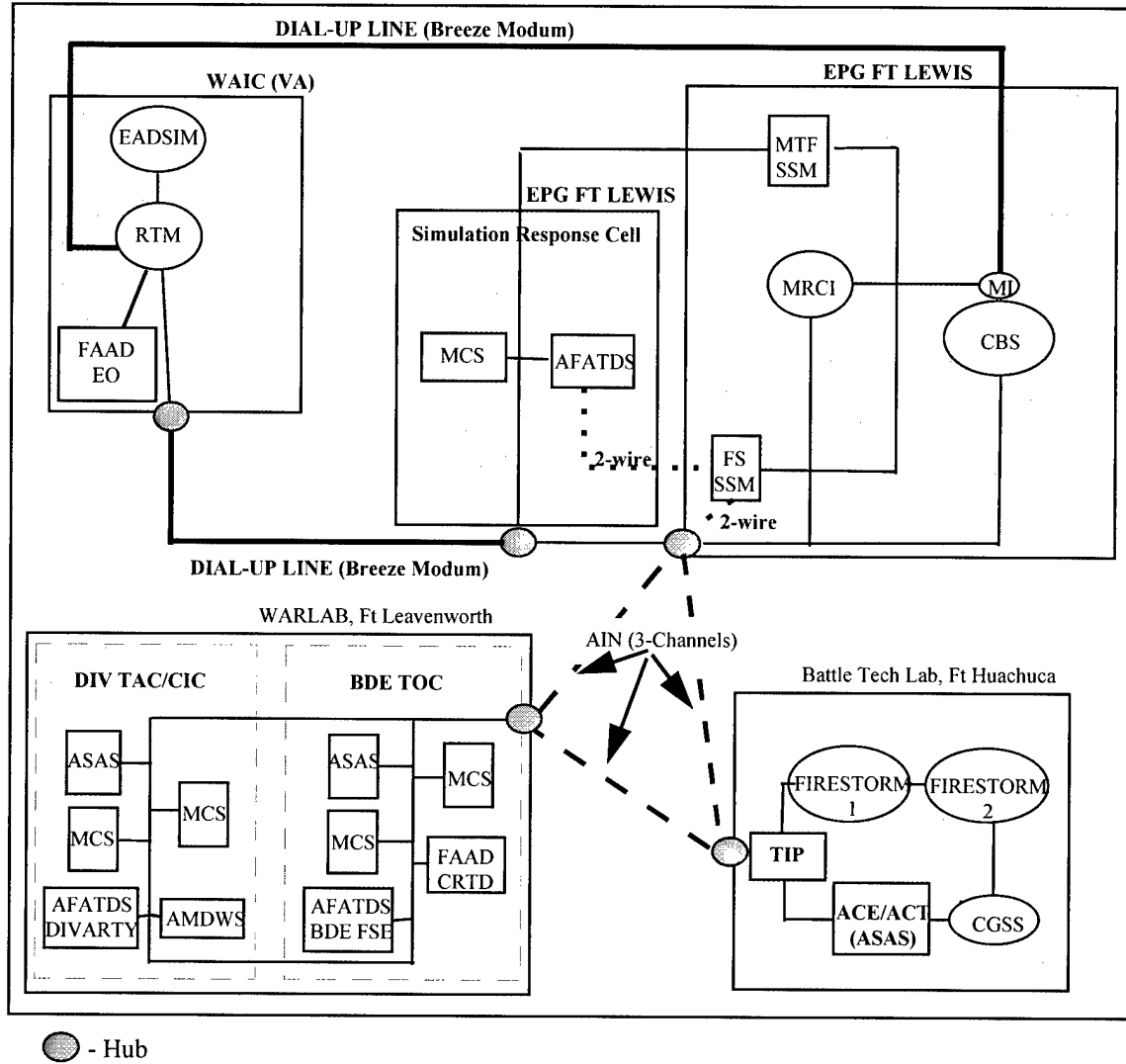

**AE 4 CLCGF  
Architecture**

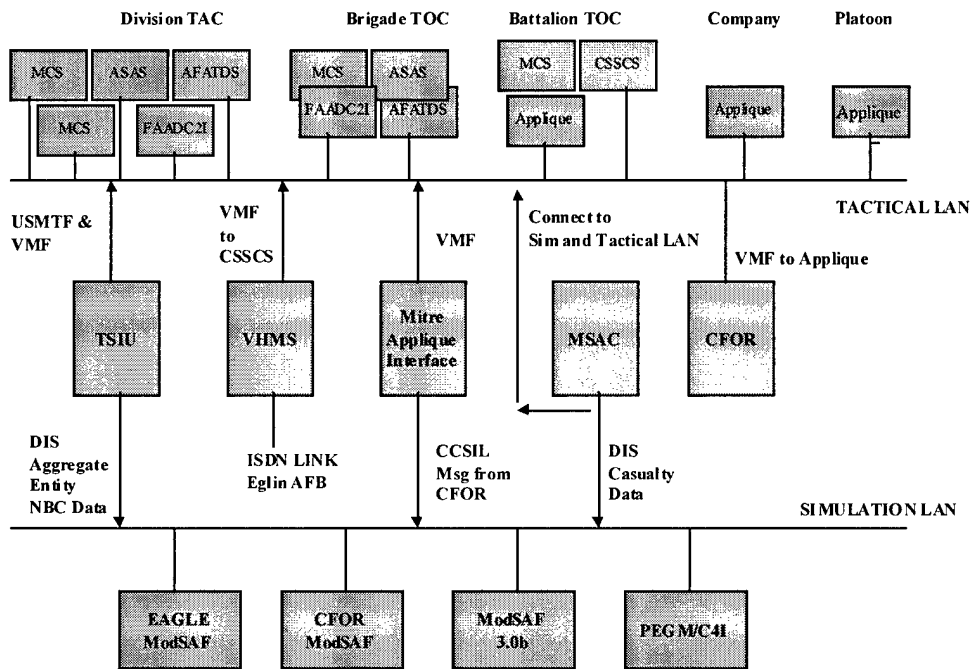

# Appendix E - AE4 Network Architecture Diagrams

## CLCGF NETWORK ARCHITECTURE

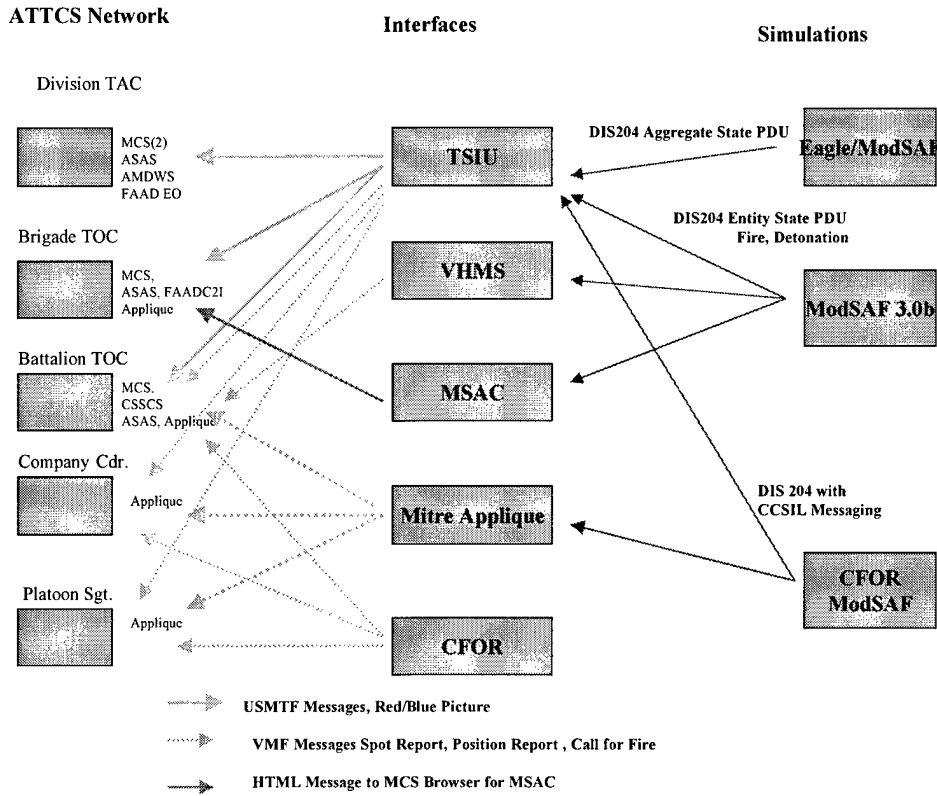

## Appendix F – CLCGF Comparison Matrix

<b>Red Order of Battle (Note 1)</b>	Y	N	N	N	N	N
<b>Moving Target Indicator (Note2)</b>	Y	N	N	N	N	N
<b>TACFIRE (Note 3)</b>	N	N	N	N	N	N
<b>MICAD NBC Sensor (Note4)</b>	Y	N	N	N	N	N
<b>Low Altitude Air Picture (Note 5)</b>	Y	N	N	N	N	N
<b>Spot Reports (Note 6)</b>	Y	Y	Y	N	N	N
<b>Positions Report (Note 7)</b>	Y	Y	Y	N	N	Y
<b>Vehicle Status Report (Note 8)</b>	N	N	N	N	N	Y
<b>FRAGO (Note 9)</b>	N	Y	Y	N	N	N
<b>Casualty Report (Note 10)</b>	N	N	N	N	Y	N
<b>OPORD (Note 11)</b>	N	Y	Y	N	N	N
<b>Call For Fire (Note 12)</b>	Y	Y	Y	N	N	N

### Notes

#### Note 1

Red Order of Battle was generated by the TSIU for the experiment using the Battlefield Geometry message to stimulate the ASAS. The CBS experiment utilized the Firestorm system to stimulate the Intelligence portion of the TOC. It was decided for cost and schedule

23 April 1998

reasons to forego this stimulation in the CLCGF experiment. The stimulation provided by the TSIU using the Red Order of Battle messages allowed for stimulation of the ASAS without a WAN connection to the classified Firestorm system. If there is a need for the stimulation of ASAS with a low-cost, medium fidelity stimulation the TSIU was shown to be an alternative for a collective training setting.

**Note 2**

An adjunct to the ASAS stimulation provided by the TSIU was the Moving Target Indicator (MTI) normally provided by JSTARS feeds. The MTI message was generated utilizing the Aggregate State PDU's from Eagle and sending these messages to ASAS. An alternative to utilizing the Eagle as the simulation engine is the use of a JSTARS simulation dedicated to reading entity and aggregate states to generate an MTI message. The major reason for not utilizing a dedicated JSTARS simulation was that they generally operate in a classified mode. The Army Experiment 4 was conducted completely unclassified.

**Note 3**

The TACFIRE message was not simulated during the Army Experiment 4. We did not have access to the TAFSIM/PIU for the experiment. The D & SA Battle Lab at Ft. Sill utilizes these simulation systems to interact the AFATDS with simulation scenarios. The systems were not available for the Army Experiment 4. As noted later a call for fire message was generated via Applique, but full interaction with AFATDS was not accomplished during AE4.

**Note 4**

The NBC sensor system was generated by the PEGEM system at the ARC in Huntsville and connected to the AE4 laboratory via normal dial-up phone line via 56KB modem. The NBC sensor sent DIS pdu's which the TSIU interpreted and sent NBC messages to the Maneuver Control Station and Applique.

**Note 5**

The low altitude air picture was generated using DIS entity state PDU's which the TSIU read and then using the information contained therein created FDL messages which stimulated the FAAD EO system which in turn alerted the AMDWS. This simulation/stimulation allows for the training of FAADC2I operators and collective training of TOC staff. During the experiment it was necessary to connect the ABCS systems with the simulation network traffic during the testing of the MSAC system. It was noted that the FAAD EO systems did not operate properly when this network configuration was in place. There was not time to ascertain the exact cause of the problem caused by the coexistence of simulation and tactical

23 April 1998

traffic on the same LAN. The FAAD EO systems would not start when the hardware was connected to the simulation LAN. This was the only problem experienced when connecting simulation and tactical systems.

#### *Note 6*

Spot reports were generated in a variety of methods during the AE4 CLCGF experiment. The CFOR ModSAF system was configured to generate messages from ModSAF simulated entities to associated Applique systems on the network. The modeling of sensors was accomplished in the CFOR ModSAF simulation. The Mitre Applique interface utilized the CCSIL messages from CFOR ModSAF to create interactions between Applique and ModSAF entities. When a spot report was generated from an Applique the Mitre Applique interface would generate a CCSIL message which would cause the ModSAF entities to respond. The TSIU interacted with these same CCSIL messages. The use of the CFOR ModSAF, Mitre Applique Interface or TSIU to interact with simulation allows tactical systems have interactions between tactical systems and simulations with human interventions to effect behaviors of simulated entities.

#### *Note 7*

Friendly position reports were generated by various systems. The TSIU utilized the DIS Entity and Aggregate PDU data to generate Blue force positions to all echelons of MCS systems and all levels of Applique systems. The Blue picture was continuously updated on tactical systems based on simulation data. The Mitre Applique Interface read DIS Entity State data and generated position reports utilizing the CCSIL message sets which interface with ModSAF. Utilizing the CCSIL messages allows for the modeling of behaviors and propagation of signals in the simulation systems. The VHMS utilized DIS data connected via dial-up connection to a vehicle on a range at Eglin AFB. This position data was used to display the position data of the live tank on the Applique screen.

#### *Note 8*

The VHMS read simulation traffic (Entity States and detonation PDU's) and generated vehicle status messages to the Applique. The updated fuel/weapons/vehicle status information was forwarded from the live vehicle to the Applique. The plan originally called for the information to be forwarded from the Applique system to the CSSCS logistics tactical system. Because of problems with software versions on the tactical systems this connection was not integrated fully. Due to time constraints the connection of tactical systems and Applique were accomplished after the test of the VHMS.

23 April 1998

**Note 9**

The Mitre Applique Interface and CFOR ModSAF were the only interfaces, which dealt with FRAGO messages. Using the modeling available with the CCSIL interface allows simulations to cause changes in behaviors of simulated entities without human intervention. The setup of the ModSAF creates realistic radio networks, which can be utilized to generate CCSIL messages, which can direct simulations to change behaviors. The FRAGO was tightly controlled so that the computers could understand the directions contained in the message.

**Note 10**

The MSAC system read DIS PDU's and generated casualty information for the MCS system. The architecture of the MSAC interface called for the addition of software to the actual MCS. This required that the MSAC system (MCS) tactical system be put on the same LAN as the simulated entities. This interface read DIS data and generated casualty reporting and allowed the operator to deploy medical assistance to the battlefield. The problems with placing the tactical and simulation systems on the same LAN are described above. No adverse conditions were caused by placing MSAC software on the MCS platform, although it should be noted that if software is added to the tactical systems any problems, which arise, are more difficult to resolve.

**Note 11**

OPORD messages were generated by the Mitre Applique interface and CFOR ModSAF system. The limitations noted in sending FRAGO messages applied also when generating OPOD messages.

**Note 12**

Call for fire messages were generated by the Applique and interfaced with simulation using the TSIU and Mitre Applique interface. Both systems interpreted the CFF message from the Applique and translated the message to CCSIL which were sent to the CFOR ModSAF system. This interface allowed for the shooting of artillery without human intervention. Modeling of correct rounds and realistic firing events were accomplished on the simulation system.

## Appendix G - AE4 Residual Products

### Products with Tangible Benefit

The AE4 experiments produced an impressive number of tangible deliverables. Six significant examples are discussed in the paragraphs below, followed by a table summarizing the remaining products. Of these six, four offer new capabilities with the potential to immediately impact the way the Army conducts Situational Awareness training.

1. The RTM used to link CBS to EADSIM and EADSIM to the FAADC2 systems. This capability was developed for assessment in AE4 and the results of the CBS Experiment show that it has the potential to immediately improve the ability of air defense soldiers to train in the planning, employment, and engagement of air defense weapon systems in the context of a CBS exercise. The RTM, together with EADSIM, significantly increased the level of resolution at which air defense events were played over CBS. As a result, it was able to realistically stimulate both AMDWS and CRTD with aircraft and missile tracks and engagement results. This capability would provide a much more realistic training environment for air defense soldiers than is currently supported in CBS exercises. Details of RTM performance are contained in Chapter 3.
2. The TSIU was used to link both Eagle and ModSAF to Appliqué and the ATCCS systems. Although the TSIU had been in use before AE4, the number and type of tactical messages that it is capable of handling was increased for AE4. AE4 also marked the first time that the TSIU had operated on CCSIL messages in the latest release of ModSAF (development version STOW 97) and the first time the TSIU had been used to send fire commands to artillery units within ModSAF. During AE4, the TSIU proved to be a robust and reliable interface between ModSAF and the ATCCS and Appliqué systems. It was also able to pass information to ATCCS on units played at the aggregate level in Eagle and "ghosted" in ModSAF. Details of TSIU's performance and capabilities are contained in Chapter 4.
3. The Soldier Visualization Station (SVS). The SVS was a new system for AE4 that was demonstrated in the DBBL Experiment. The SVS is a PC-based, commercial, off-the shelf product that is one of the latest developments in Individual Combatant (IC) virtual simulators. The SVS provides a realistic training capability for military operations in urban terrain (MOUT) and other critical IC tasks. It provided a good illustration of how PC-based equipment can provide acceptable virtual (human-in-the-loop) simulation at a significantly lower cost than previously realized. When compared to existing, UNIX-based systems, SVS

23 April 1998

provides about one-fourth the visual resolution (640X480 versus 1280X1024) at about the same frame rate on the same database for about one-twentieth the cost. This makes it feasible to develop squad and platoon sized virtual training systems for dismounted soldiers. SVS details are provided in Chapter 5.

4. A link between the Land Warrior system and Appliqué. While planning for the DBBL portion of the Experiment, it was discovered that Land Warrior and Appliqué had not been linked and, therefore, could not exchange situational awareness data. This means, for example, that the position and status of a dismounted soldier with the Land Warrior system could not be displayed on the Appliqué system in the squad leader or platoon leader's fighting vehicle. Although this seemed to be an obvious requirement, it had not been funded under either program. AE4 provided funding and a context in which to develop and assess such a linkage. Note that this link is between two real-world C4I systems and has applications both for training and for actual operations.

5. The MITRE ModSAF Appliqué Interface (MMAI). The MMAI provided a two way VMF interface between Appliqué systems and the ModSAF simulation. The MMAI was actually a federation of simulations and interfaces based on the High Level Architecture (HLA). The MMAI development effort demonstrated the potential of the HLA to provide a framework for integrating C4I systems with simulations. The baseline capability was extended by introducing realistic communications effects. Assessment of the MMAI was limited due to resource constraints. However, the MMAI did demonstrate, among other things, an approach to provide a realistic simulation of communications effects for Situational Awareness training.

In addition to these four products, AE4 produced two significant products that could directly benefit Situational Awareness training, but that would require more development to do so. Nevertheless, they offer significant potential for improving the Army's training capabilities.

1. The Medical Situational Awareness and Control (MSAC) system added two new capabilities to the systems examined during the CLCGF Experiment: the simulation of personnel casualties using ModSAF PDU's, and support for a unit's medical staff in the management of medical care in combat. ModSAF, with the MSAC software added, was the only simulation examined in AE4 capable of reporting realistic numbers and types of casualties based on combat action. In AE4 these reports were received on a Beta version MCS workstation to which had been added the MSAC medical command and control module. The combination of casualty simulation and medical support management demonstrated by MSAC has the potential to greatly increase the training opportunities for medical support personnel.

2. The Vehicle Health Monitoring System (VHMS) is intended to allow maintenance personnel to gain Situational Awareness of the maintenance status of every vehicle in their unit. In its final form VHMS will comprise a monitoring system on the vehicle and a maintenance module on the CSSCS workstation. In the CLCGF Experiment both a live maintenance module (on a tank located at Eglin Air Force Base) and simulated maintenance modules (using VHMS software together with ModSAF) were used to feed current maintenance status to CSSCS via Appliqué. Although problems were encountered with the Appliqué to CSSCS link, VHMS successfully demonstrated a maintenance concept with potential applications in both training and real-world operations.

The remaining tangible results are summarized in Table A-1 below. Each result is placed into a category based on its support for the development of doctrine, training, leader development, and organization, material or soldier systems (DTLOMS).

Table F-1 Tangible Products from AE4.

<b>Category</b>	<b>Tangible Results</b>	<b>Description and Potential Uses</b>
<b>Doctrine</b>	There were no doctrinal or concept issues examined during AE4 but many residuals can be used to examine doctrine and concepts in future experiments.	
<b>Training</b>	Integration of Land Warrior into SVS	Allows Land Warrior to operate in a simulation with SVS
<b>Training</b>	Terrain Database for MOUT Site into SIMNET and Appliqué	Allows SVS and M2 Bradley with Appliqué to operate and communicate in the same simulation scenario
<b>Training</b>	ModSAF-Appliqué Interface with Realistic Communications (MITRE Corporation Internal R&D Initiative)	Incorporation of realistic communications into simulation-driven exercises in order to train and experiment with the impacts of terrain and other factors affecting digitized operations
<b>Training/ Materiel</b>	Medical Situational Awareness and Control (MSAC) software development and MCS integration	Provide training for medical personnel, staff and commanders in the planning for and control of medical support assets in a simulation-driven exercise.
<b>Training/ Materiel</b>	Vehicle Health Monitoring System (VHMS) development and CSSCS/Appliqué integration	Provide training for logistics personnel in managing and responding to vehicle damage and maintenance problems in a simulation-driven exercise.
<b>Leader Development</b>	Usable C4I/Simulation Architecture	Base for Digital Reaction Courses, particularly in the WarLab at Fort Leavenworth and at

Category	Tangible Results	Description and Potential Uses
		officer training centers such as Fort Knox and Fort Benning
<b>Organizations</b>	There were no organizational change issues examined during AE4. However, many residuals can be used to assist in the examination of organizational structures in future experiments, particularly in the Tactical Decision-Making Process experiments at Fort Leavenworth BCBL (L)), in the brigade and below staff organization (Fort Knox MMBL) and in Tactics, Techniques and Procedures for Army XXI being developed at Training Centers.	
<b>Materiel</b>	Land Warrior-to-Appliqué Interface software	The development of a link between the Land Warrior information system and Appliqué, allowing the individual soldier system to become a part of the FCB2 network
<b>Materiel</b>	Medical Situational Awareness and Control (MSAC) software development and MCS integration	Provide digitized system for medical personnel, staff and commanders for the planning and control of medical support assets in a tactical environment.
<b>Materiel</b>	Vehicle Health Monitoring System (VHMS) development and CSSCS/Appliqué integration	Provide digitized system for logistics personnel in managing and responding to vehicle damage and maintenance problems in a tactical environment
<b>Materiel</b>	Air and Missile Defense Work Station (AMDWS) development	Follow on system to the Forward Area Air Defense Command and Control and Intelligence (FAADC2I) system that is a part of ATCCS
<b>Materiel</b>	Simulation Interface Unit (SIU) development	During AE4 the SIU version that was designed to work with the newest versions of ModSAF and Eagle simulations was placed into service and software problems were corrected
<b>Soldier Systems</b>	N/A	

## Products with Intangible Benefit

Some of the most significant results of the AE4 program were in the form of intangible benefits. The AE4 experiments were monitored by a number of military and civilian subject matter experts whose observations make up a large part of this report. The backgrounds of these observers include enlisted system operators and staff officers from the 4ID, technical representatives of the PEOC3S, civilian analysts and technicians from government agencies, civilian contractors, and Federally Funded Research and Development Center (FFRDC) staff. All key observers as a check on correctness and objectivity reviewed a draft of this report. Table F-2 provides a summary of intangible benefits from the AE4 experiments.

Table F-2 Intangible Benefits from AE4

<b>Category</b>	<b>Intangible Benefit</b>	<b>Description and Potential Uses</b>
<b>Doctrine</b>	Not applicable	
<b>Training</b>	MRCI: Knowledge about how MRCI works as an interface between CBS & MCS	Design feedback to MRCI developers and a roadmap for future development
<b>Training</b>	FIRESTORM: Knowledge and experience in using it in a CBS confederation over a distributed network	Decisions regarding further development and methods for incorporating it into both distributed and on-site simulations and exercises.
<b>Leader Development</b>	Not applicable	
<b>Organizations</b>	Not applicable	
<b>Material</b>	Battle Lab Integrated Concept Emulation Program (BICEP) "experiment" simulation/C4I architecture, structure, and scenario	AE4 CLCGF experiment structure and scenario will be used in BICEP simulator demonstration during the Division AWE to examine aviation capabilities and force structure
<b>Materiel</b>	ATCCS: Information regarding local networking, connectivity and use	Experiences of system technicians and comments from system operators during the experiments can assist in development and product improvement
<b>Materiel</b>	Simulations in general	Several development teams (including WARSIM) are interested in capturing the lessons learned from AE4 to assist in development of their products
<b>Soldier Systems</b>	Not applicable	

23 April 1998

Perhaps the greatest value of AE4 is in the intangible residuals - the knowledge and lessons learned gained through documented observations by subject matter experts. If properly disseminated, these residuals can directly support ongoing Army programs, such as WARSIM, that are focused on developing simulation/interface systems for training.

## Appendix H - Points of Contact (POC's)

TITL		NAME	ORGANIZATION	DSN	PHONE #	FA	E-MAIL	EXP
CPT	John	Amick	DBBL, Ft Benning	835	(706) 545-9214	3096	amickj@benning-emh2.army.mil	LW
LTC	John	Anderson	SMDC	645	(205) 955-1776	3994	andersonj@ssdch.usassdc.army.mil	CBS
LTC	Tim	Anderson	NSC	552	(913) 684-8133	8137	andersob@leav-emh1.army.mil	CBS- NSC
Mr	Paul	Barham	Reality By Design (LW)		(408) 655-0440	885	barham@rbd.com	LW-SVS
Dr	Kent	Bimson	SAIC w/LM		(407) 306-5631	4077	kent.bimson@lmco.com	CBS/CL-data collection
Mr	Joe	Brennan	STRICOM	970	(407) 384-3855	3830	joe_brennan@stricom.army.mil	ALL
Mr	John	Campbell	STRICOM / PM-CAAN	970	(407) 384-3661 pager 800.549.3213	3660	john_campbell@stricom.army.mil	DEMO
Mr	James	Cannon	Hughes Aircraft (AMBL)		(310) 616-3401	3402	Jjcannon@ccgate.hac.com	LW
Mr	Jan	Chervenak	DBBL, Ft Benning	835	(706) 545-7000	7032	Jan9538@aol.com	LW
MAJ	Tom	Coffman	STRICOM / PM-CAAN	970	(407) 384-3672	3660	tom_coffman@stricom.army.mil	ALL
Mr	Dale	Coffman	CAI/NSC-MRCI	552	(913) 684-8425		coffmand@leav-emh.army.mil	CBS
Mr	Mike	Collins	Cubic Applications, Inc.		(913) 680-2046	3566	collinsm@leav-emh1.army.mil	ALL
Ms	Veronica	Collins	SMDC	645	(205) 955-5405	3994	collinsv@ssdch-usassdc.army.mil	CBS/CL
Mr	Tom	Engle	EPG FLFO	357	(253)967-7761		tnglt@lewis-epg.army.mil	CBS - Comms
Ms	Colleen	Finnerty	SAIC		(407) 306-2066 pager 1.800.528.0799	4077	colleen_finnerty@ccmail.orl.mmc.com	ALL
Mr	Dan	Fugit	Coleman Research Corp.		(205) 922-6010 x3188	6053	dfugit@hsv.crc.com	CBS/CL
Mr	Wes	Hamm	Mitre		(703) 883-6403	1379	whamm@mitre.org	CBS LEAD
Ms	Beverly	Harbin	SMDC	645	(205) 955-2377	3994	harbinb@ssdch-usassdc.army.mil	CBS/CL
Mr	Roger	Hewitt	Omega Training (DBBL)		(706) 569-9100	7400	rlhewitt@aol.com	LW- training
MAJ	Bob	Hoelscher	NSC	552	(913) 684-8168	8171	hoelschr@leav-emh1.army.mil	CBS- lvn
Mr	Sterling	Ingram	EPG-FLFO	357	(253)967-8321		ingrams@lewis-epg.army.mil	CBS
Mr	Joe	Jennings	MITRE		(703) 441-7227	1779	jjennings@mitre.org	ALL
Ms	Tami	Johnson	EPG-FLFO	357	(206) 967-8321		johnsont@lewis-epg.army.mil	CBS-lewis
LTC	Claude	Jones	PEOC3S	992	(908) 532-5382		jonesc@doim6.monmouth.army.mil	ALL-PEOC3S
Mr	Mike	Kalaf	Lockheed Martin		(407) 306-4051 pager 800.474.5516	4075	Mike.Kalaf@lmco.com	ALL

23 April 1998

Mr	Ed	Kaster	CAI-NSC	552	(913) 684-8422	4075	kastere@leav-emh1.army.mil	CBS-MRCI
Mr	Randy	Kubik	TASC		(407) 306-4417 pager 1.800.558.6312	4388	randy.kubik@ccmail.orl.mmc.com	ALL/CL LEAD
Mr	Dan	Leigeber	CRC		(205) 922-6000	6053	dleigeber@mail.crc.com	CL-TSIU
LTC	Rick	Levine	USAMRMC (AMEDD)	343	(301) 619-7674	2416	ltc_richard_levine@ftdetreckccmail.army.mil	CL-MSAC
MSG	Bob	Lopez	BCBL (H)	821	(520)533-1888		lopezr@huachuca-emh30.army.mil	CBS- firestorm
Mr	Randy	Mynahan	Mystech		(407) 629-8905		rmynahan@mystech.com	CL-MSAC
Mr	Richard	Nelson	EPG-FLFO	357	(253) 967-8128	964-	nelsonr@lewis-epg.army.mil	CBS-lewis
Mr	Red	Natkin	Mystech		(703) 331-0906 x308	361-	rnatkin@mystech.com	CL-MSAC
Mr	Randy	Noble	Image Tech Svcs, Inc		(407) 843-0043	5876	rnoble@imageits.com	AV Supplier
Mr	Kelvin	Nunn	MICOM (Loglab)	788	(205) 842-6529	842-	knunn@redstone.army.mil	CL-VHMS
Mr	Jim	Nye	CECOM RDEC - AIN	992	(908) 532-8212	3398	nye@ain3.monmouth.army.mil	CBS-AIN
SGM	Joe	Pearson, Jr.	4th ID, G3	737	(817) 287-3131	6013	PearsonJ1@hood-emh3.army.mil	ALL-div tac
LTC	Scott	Piro	SMDC	327	(703) 607-2043	3853	piros@ssdcw-usassdc.army.mil	CBS
Mr	Jim	Pittman	MITRE	552	(913) 684-8289	8299	pittmanj@leav-emh1.army.mil	CBS/CL
Mr	Dominick	Pondaco	PEOC3S FIO	992	(908) 532-0101	5464	pondaco@doim6.monmouth.army.mil	All-PEOC3S
Mr	Billy	Potter	Lockheed Martin LWTB		(706) 682-5300	4499	Billy.h.potter@lmco.com	LWTB
Mr	Dave	Prybyla	EPG-FLFO	357	(206) 964-1611x18	9676	prybylad@lewis-epg.army.mil	CBS-lewis
Mr	John	Ratzenberger	TRAC-Leav	552	(913) 684-9235	9232	ratzenbj@trac.army.mil	CL-EAGLE
MAJ	Keith	Reck	BCBL-Leavenworth	552	(913) 684-2358 (913)384-3033	2358	reckk@leav-bcbl.army.mil	CBS-warlab
Mr	Dennis	Reeder	Maguire/Reeder		(703) 519-9300	9306	dennis@maguire-reeder.com	DEMO
Mr	Zig	Roebuck	CRC		(205) 922-6000	6053	zjr@hsv.crc.com	CBS/CL
Mr	David	Sargent	NSC-CBS	552	(913) 684-8155	8137	sargentd@leav-emh1.army.mil	CBS-LVN
Mr	Tim	Schmidt	Coleman Research Corp.		(205) 922-6010x3005	6053	tim_schmidt@mail.crc.com	CBS/CL
Mr	John V.	Smith	MICOM (LOGLAB)	746	(205) 876-1802	8407	jvsmith@redstone.army.mil	CL-VHMS
Mr	Don	Steele	CRC		(703) 415-4760	4536	don_steele@mail.crc.com	DEMO

23 April 1998

LTC	Larry	Steiner	TRADOC	680	(757) 727-2008	2947	steinerl@emh6.monroe.army.mil	ALL- Lead DOG
Mr	Bob	Strider	SMDC	645	(205) 955-5981	3994	striderb@ssdch-usassdc.army.mil	CBS-RTM
Mr	John	Traylor	PM ADCCS/PM-TOC	788	(205) 895-4283	3148	jtraylor@adccs.redstone.army.mil	ALL-PM TOC
Mr	Jorge	Vela	SAIC		(407) 306-3735	4077	Jorge.g.vela@lmco.com	LW-
Mr	Greg	Wenzel	Booz Allen		(703)908-4342		wenzel_greg@bah.com	CBS-RTM
Mr	Ken	Wren	Cubic Applications, Inc.	552	(913) 684-4042	3566	wrenk@leav-emh1.army.mil	ALL-ADMIN

## Appendix I - Residual GFP/GFE

### Government Furnished Equipment

DESCRIPTION	S/N	MODEL	SITE	OWNER	QTY
POWER SUPPLY	217688	T512500/1	OSF	AE4	1
POWER SUPPLY	217825	T512500/1	OSF	AE4	1
POWER SUPPLY	217856	T512500/1	OSF	AE4	1
POWER SUPPLY	272804	T512500/1	OSF	AE4	1
POWER SUPPLY	272809	T512500/1	OSF	AE4	1
POWER SUPPLY	272905	T512500/1	OSF	AE4	1
POWER SUPPLY	272924	T512500/1	OSF	AE4	1
POWER SUPPLY	272942	T512500/1	OSF	AE4	1
POWER SUPPLY	272949	T512500/1	OSF	AE4	1
POWER SUPPLY	272975	T512500/1	OSF	AE4	1
MICROPHONE, SAMSON		BH-3	OSF	AE4	1
HEADSETS FOR INTERCOM SYSTEM			OSF	AE4	4
POWER STRIPS			OSF	AE4	10
TABLES			OSF	AE4	12
BOX FAN			OSF	AE4	10
VIDEO CABLES FOR SIG RGB w/o EXT. SYNS			OSF	AE4	10
S VIDEO CABLES FOR LARGE MONITORS			OSF	AE4	10
MICROPHONE FOR CB RADIO	NONE	HMN9725D	OSF	AE4	6
EARPIECE CABLE AND CLAMP FOR CB RADIO	NONE	HMN9727BR	OSF	AE4	5
BATTERY, SPARE, FOR HANDHELD RADIO	NONE	HNN9628A	OSF	AE4	6
POWER SUPPLY	1066070119	AA16600	OSF	AE4	1
CAMO SCREENING SYSTEM	1080012661824		OSF	AE4	4
CAMERA, QUICK CONNECTIX			OSF	AE4	1
FAX, INTERNAL, CARDINAL	7354212315U7	P21J-12	OSF	AE4	1
THEATER, AE3/4			EXHIBIT CRAFTS	AE4	1
LIGHT BOARDS, 8ft			EXHIBIT CRAFTS	AE4	16
MEDALIONS, AE3			EXHIBIT CRAFTS	AE4	4
LIGHT BOARD PANELS W/FRAME			EXHIBIT CRAFTS	AE4	13
COFFEE POT, 30 CUP	NSN		OSF	AE4	1

### Government Furnished Property

Site	OWN	ITEM#	DESC	SERIAL_NO	BINLOC
AVTB	AE4	LM01293	ROUTER, CISCO 4500-M TOPASY	45510834	SUPPLY
FT LVN	AE4	A25015	COMPUTER, LAPTOP	23-791ND	AE4
FT LVN	AE4	A24636	CPU, COMPAQ DESKPRO 590	A539HSX2E185	AE4
FT LVN	AE4	81818659	CPU, COMPAQ PROLINEA	G551HSK40340	AE4
FT LVN	AE4	60043926	CPU, COMPAQ PROLINEA 5133	A546HSK4D442	AE4

FT LVN	AE4	AE4T01	CPU, NOTEBOOK 486 DS2	X415NTM0033-3	AE4
FT LVN	AE4	A24637	KEYBOARD, COMPAQ	1LJ39CH09912	AE4
FT LVN	AE4	37505693	MONITOR, COMPAQ 17"	532CB02AG854	AE4
FT LVN	AE4	A24638	MONITOR, COMPAQ 17" COLOR	525CB02AB085	AE4
FT LVN	AE4	60244849	MONITOR, COMPAQ 17" COLOR	532CB02AG851	AE4
FT LVN	AE4	50828595	PRINTER, BROTHER	L53367808	AE4
FT LVN	AE4	64567108	PRINTER, HP DeskJet 850C	SG56L1510J	AE4
LWTB	AE4	LM02609	COMPUTER, LAPTOP	J712BJJ98253	STKRM2866
LWTB	AE4	LM60100	ETHERNET, MULTIPOINT	00044300096050KL	STKRM2866
LWTB	AE4	LM60853	RGB DISTRIBUTION AMPLIFIER	337363	BAY1
MWTB	AE4	A22870	HUB	E1614197	BAY2
MWTB	AE4	A22868	HUB	E1624197	BAY2
MWTB	AE4	A22873	HUB	GOB04210	KX-DA
MWTB	AE4	A22871	HUB, AUI - 10 BASE T	EJ834194	KX-CR
MWTB	AE4	A22844	MONITOR	7202090	BAY2
MWTB	AE4	A22906	SGI KEYBD	4093	BAY1
OSF	AE4	LM01773	AUTOMATION CONTROL MODULE	F11013	E6
OSF	AE4	LM01499	BATTERY CHARGER FOR GP300	9611KS	M2BSTKRM
OSF	AE4	LM01908	CASE (INSIDE), PART OF LM01903		E6
OSF	AE4	LM02800	CASE, ARMADILLO		M2BSTKRM
OSF	AE4	LM01531	CASE, ARMADILLO		M2BSTKRM
OSF	AE4	LM01530	CASE, ARMADILLO		M2BSTKRM
OSF	AE4	LM02799	CASE, ARMADILLO		M2BSTKRM
OSF	AE4	LM02704	CASE, ARMADILLO, FM		M2BSTKRM
OSF	AE4	LM02801	CASE, ARMADILLO, MONITOR		M2BSTKRM
OSF	AE4	LM01903	CASE, ARMADILLO, RACK ASSEMBLY-C		M2BSTKRM
OSF	AE4	LM02796	CASE, ARMADILLO, SGI		M2BSTKRM
OSF	AE4	LM02795	CASE, ARMADILLO, SGI		M2BSTKRM
OSF	AE4	LM02794	CASE, ARMADILLO, SGI COMPUTER		M2BSTKRM
OSF	AE4	LM02797	CASE, ARMADILLO, SGI COMPUTER		M2BSTKRM
OSF	AE4	LM02798	CASE, ARMADILLO, SOUND STORM EQ		M2BSTKRM
OSF	AE4	LM02806	CASE, ARMADILLO, UTILITIES		M2BSTKRM
OSF	AE4	LM02607	CD-ROM DRIVE	6633A51379	M2BSTKRM
OSF	AE4	LM02606	CD-ROM DRIVE	6634A50037	M2BSTKRM
OSF	AE4	LM02610	COMPUTER, LAPTOP	J712BJJ98634	M2BSTKRM
OSF	AE4	LM02605	CPU, APOLLO	6321A01299	M2BSTKRM
OSF	AE4	LM02604	CPU, APOLLO	6346A00049	M2BSTKRM
OSF	AE4	LM01495	CPU, GATEWAY 2000	2601609	M2BSTKRM
OSF	AE4	LM01186	CPU, INDY R4000	08006907B4D3	STOWLAB
OSF	AE4	LM00798	CPU, INDY R4000	08006907B4DA	M3B1C261
OSF	AE4	LM01189	CPU, INDY R4000	080069088CAF	M2BSTKRM
OSF	AE4	LM01913	CPU, INDY R4000	080069088CB5	M2BSTKRM
OSF	AE4	LM00812	CPU, INDY R4000	08006908927C	STOWLAB
OSF	AE4	LM01086	CPU, INDY R4400 175MHZ	0800690923B7	M2B1C082

OSF	AE4	LM02613	CPU, INTEL	NSN1243142	M2BSTKRM
OSF	AE4	LM02614	CPU, INTEL	NSN1243143	M2BSTKRM
OSF	AE4	LM02615	CPU, INTEL	NSN1243144	M2BSTKRM
OSF	AE4	LM02522	CRT W/KEYBOARD	OHZ15C00663	HIGHBAY
OSF	AE4	LM02793	DeskJet PRINTER 694C	SG6CG1Q0NB	M2BSTKRM
OSF	AE4	LM02612	DOCKING STATION	J726HQX19825	M2BSTKRM
OSF	AE4	LM02611	DOCKING STATION	J726HQX1A017	OFF SITE
OSF	AE4	LM01452	HUB	G09N5062H	M2BSTKRM
OSF	AE4	LM01451	HUB	G0DR5062H	M2BSTKRM
OSF	AE4	LM01455	HUB	G0ER5062H	M2BSTKRM
OSF	AE4	LM01287	HUB	G0F35062H	M2BSTKRM
OSF	AE4	LM01143	HUB, 8-PORT, BNC, AUI	FORB5145B	SIMLAB
OSF	AE4	LM00807	HUB, AUI - 10 BASE T	EJ154197	M2BSTKRM
OSF	AE4	LM01526	HUB, AUI - 10 BASE T	EJ164197	M2BSTKRM
OSF	AE4	LM01465	HUB, AUI - 10 BASE T	EJ274194	M3BSTKRM
OSF	AE4	LM00858	HUB, AUI - 10 BASE T	EJ684194	M2BSTKRM
OSF	AE4	LM01453	HUB, REPEATER, FOIRL / 10BASE2	G0AN5129A	M2BSTKRM
OSF	AE4	LM01454	HUB, REPEATER, FOIRL / 10BASE2	G0C75129A	M2BSTKRM
OSF	AE4	LM01907	IF4B WIRE INTERFACE	BER 563763	E6
OSF	AE4	LM01091	KEYBOARD	00009486	STOWLAB
OSF	AE4	LM00799	KEYBOARD	00009931	SIMBAY
OSF	AE4	LM00813	KEYBOARD	00020770	M2BSTKRM
OSF	AE4	LM01194	KEYBOARD	00031466	M2BSTKRM
OSF	AE4	LM01198	KEYBOARD	407Z4301053	SIMBAY
OSF	AE4	LM01527	KEYBOARD, GATEWAY 2000	01217555	M2BSTKRM
OSF	AE4	LM02622	KEYBOARD, SOUNDSTORM	01018646	M2BSTKRM
OSF	AE4	LM01002	KEYBOARD, WYSE	407Z4301057	M3BSTKRM
OSF	AE4	LM01772	MIC/LINE MIXER, 16 CHANNEL	LM01773	E6
OSF	AE4	LM02618	MONITOR	FCA71400940	M2BSTKRM
OSF	AE4	LM02617	MONITOR	FCA71401114	M2BSTKRM
OSF	AE4	LM02616	MONITOR	FCA71404952	M2BSTKRM
OSF	AE4	LM02620	MONITOR	JPO1083721	M2BSTKRM
OSF	AE4	LM00959	MONITOR, 16" MULTI-SCAN	7203053	M2BSTKRM
OSF	AE4	LM00811	MONITOR, 20" MULTI-SCAN	2413342	MAINTRM
OSF	AE4	LM01693	MONITOR, 20" MULTI-SCAN	2428374	STOWLAB
OSF	AE4	LM02621	MONITOR, APOLLO	JPO1065428	M2BSTKRM
OSF	AE4	LM00224	MONITOR, COMPAQ	532CB02AG843	M2BSTKRM
OSF	AE4	LM01695	MONITOR, MULTISCAN	7215071	E6
OSF	AE4	LM01315	MONITOR, SONY	2506307	M2BSTKRM
OSF	AE4	LM01309	MONITOR, SONY	505002	M2BSTKRM
OSF	AE4	LM01337	MONITOR, WYSE	OLU14500694	M2BSTKRM
OSF	AE4	LM01302	PHONE, DIGITAL, CORDLESS	10079513047	E6
OSF	AE4	LM01303	PHONE, DIGITAL, CORDLESS	10079513048	E6
OSF	AE4	LM01305	PHONE, DIGITAL, CORDLESS	1030596001841	E6

OSF	AE4	LM01909	PRINTER, DeskJet 320	MY4C12M0BJ	M2BSTKRM
OSF	AE4	LM01153	PRINTER, DeskJet 850C	US56B110S7	M3B2C012
OSF	AE4	LM00229	PRINTER, HP	236023	M2B1C091
OSF	AE4	LM00793	REPEATER, CENTRECOM	F42Y5196B	SIMBAY
OSF	AE4	LM01414	RGBS LINE DRIVER	135803	M2BSTKRM
OSF	AE4	LM01416	RGBS LINE DRIVER	135806	M2BSTKRM
OSF	AE4	LM01415	RGBS LINE DRIVER	135812	M2BSTKRM
OSF	AE4	LM01417	RGBS LINE DRIVER	135815	M2BSTKRM
OSF	AE4	LM00223	SCANNER, MICROTEK	S5B7508210	M2B1C091
OSF	AE4	LM01538	SINGLE CHANNEL INTERCOM SYSTEM	A076107	E6
OSF	AE4	LM01537	SINGLE CHANNEL INTERCOM SYSTEM	A076108	E6
OSF	AE4	LM01533	SINGLE CHANNEL INTERCOM SYSTEM	A076109	E6
OSF	AE4	LM01534	SINGLE CHANNEL INTERCOM SYSTEM	A076110	E6
OSF	AE4	LM01532	SINGLE CHANNEL INTERCOM SYSTEM	A076111	E6
OSF	AE4	LM01536	SINGLE CHANNEL INTERCOM SYSTEM	A076112	E6
OSF	AE4	LM01539	SINGLE CHANNEL INTERCOM SYSTEM	A076113	E6
OSF	AE4	LM01535	SINGLE CHANNEL INTERCOM SYSTEM	A076114	E6
OSF	AE4	LM01906	SOUND SYSTEM, ADAPT-A-COM	BER-564839	E6
OSF	AE4	LM01905	SOUND SYSTEM, ADAPT-A-COM	BER-564840	E6
OSF	AE4	LM01904	SOUND SYSTEM, MAIN STATION	BER-565303	E6
OSF	AE4	LM01256	SPACEBALL	0595032427	M2BSTKRM
OSF	AE4	LM00976	SPACEBALL W/ POWER SUPPLY	0192072173	M2BSTKRM
OSF	AE4	LM01697	SPEAKER		M2BSTKRM
OSF	AE4	LM01696	SPEAKER		M2BSTKRM
OSF	AE4	LM00558	SPEAKER, ACCOUSTIMASS 5 SE	AM5B0XM595366	M2BSTKRM
OSF	AE4	LM00559	SPEAKER, BOSE, ACCOUSTIMASS 5 SE	AM5B0XM492412	M2BSTKRM
OSF	AE4	LM00608	SPEAKERS, MINI, BOSE		M2BSTKRM
OSF	AE4	LM00607	SPEAKERS, MINI, BOSE		M2BSTKRM
OSF	AE4	LM00605	SPEAKERS, MINI, BOSE		M2BSTKRM
OSF	AE4	LM00606	SPEAKERS, MINI, BOSE		M2BSTKRM
OSF	AE4	LM01912	STAND, VIDEO/ AV	NSN	STOWLAB
OSF	AE4	LM01775	STEREO AMPLIFIER	029481433	E6
OSF	AE4	LM01774	STEREO AMPLIFIER	129370793	E6
OSF	AE4	LM02705	SYNTHESIZED VHF-FM RECEIVER	05188	M2BSTKRM
OSF	AE4	LM01463	TELEPHONE, CELLULARONE	157-08449462	M2BSTKRM
OSF	AE4	LM01365	TELEPHONE, PORTABLE CELLULAR	15603452675	OFF SITE
OSF	AE4	LM01366	TELEPHONE, PORTABLE CELLULAR	15603558138	OFF SITE

OSF	AE4	LM01203	TERMINAL, WYSE	OLU14500649	SIMBAY
OSF	AE4	LM01651	VACCUUM, UPRIGHT	099500527913	M2BSTKRM
OSF	AE4	LM01502	WALKIE TALKIE, MOTOROLA	174FWE3612	M2BSTKRM
OSF	AE4	LM01504	WALKIE TALKIE, MOTOROLA	174FWE3660	M2BSTKRM
OSF	AE4	LM01500	WALKIE TALKIE, MOTOROLA	174FWE3676	M2BSTKRM
OSF	AE4	LM01501	WALKIE TALKIE, MOTOROLA	174FWE3735	M2BSTKRM
OSF	AE4	LM01505	WALKIE TALKIE, MOTOROLA	174FWE3819	M2BSTKRM
OSF	AE4	LM01503	WALKIE TALKIE, MOTOROLA	174FWE4172	M2BSTKRM
OSF	AE4	LM01911	WIDE BODY TV STAND	50AA0935	STOWLAB
OSF	AE4	LM01910	WIRELESS TRANSMITTER W/ MIC	None	M2BSTKRM
OSF	AE4	LM00222	ZIP DRIVE, 100MB IOMEGA	RB0F51A0WM	M2B1C091

## Appendix J - Organization Structure

ORGANIZATION	FUNCTION	
<b>TRADOC</b>	Sponsor	
<b>STRICOM</b>	ADST II Agency	
LMIS	ADST II Contractor	
LMSG	Site Support, Materials, Facilities, DBase Dev, Eagle, ModSAF	
SAIC	Personnel Support	
TASC	Personnel Support	
AEgis	Personnel Support	
Reality By Design	SVS, LWTB Support	
Hughes	LW System	
Cubic Applications	Personnel Support	
Image Technical Support	Audio Video Design, Supply & Support	
Ulf Helgesson	Exhibit Designer	
Exhibit Crafts	Exhibit Builder, Show Support, Storage	
<b>DBBL</b>	LWTB Support	
<b>US Army Space &amp; Missile Defense Command</b>		
<b>Battle Command Battle Lab Ft. Huachuca</b>	FIRESTORM	

ORGANIZATION	FUNCTION
<b>NSC</b>	WARLAB Facility, Resources
<b>EPG</b>	SSMs, Facilities, Resources
<b>PEOC3S</b>	ATCCS, Resources
TRW	AMDAS, Applique
<b>PM Air Defense Com &amp; Control System</b>	ATCCS Support
<b>PM Intel Fusion</b>	ATCCS Support
<b>USAMRMC</b>	Tele-Med
Mystech	Tele-Med Support (MSAC)
<b>MICOM</b>	Pass Through - CRC
CRC	CD ROM
Maguire-Reeder	Introduction Theater Video, Multi-Media
<b>CECOM</b>	Pass Through - Mitre
Mitre	TRADOC Technical Advisor
<b>SMDC</b>	TSIU, RTM, Simulation Support
CRC	TSIU & Sim Support
Booze-Allen Hamilton	RTM
Mevatec	PEGEM Sim
<b>Avn &amp; Missile Com</b>	VHMS Development & Support
<b>GSA</b>	MRCI for CBS
SAIC	

## Appendix K - GLOSSARY

AAR	After Action Report
ABCS	Army Battle Command Systems
ACR	Advanced Concepts Requirements
A/C	Air Conditioning
ADST	Advanced Distributed Simulation Technology
AE3	Army Experiment III
AE4	Army Experiment IV
AMC	Army Material Command
AMP	Ampere
AO	Area of Operations
AFATDS	Advanced Field Artillery Tactical Data System
ASAS	All Source Analysis System
AT&T	American Telegraph and Telephone Company
ATCCS	Army Tactical Command and Control System
AUSA	Association of the United States Army
BDS-D	Battlefield Distributed Simulation - Developmental
BTU	British Thermal Unit
C2	Command and Control
C2V	Command and Control Vehicle
C4I	Command, Control, Communications, Computers & Intelligence
CBS	Corps Battle Simulation
CLCGF	Corps Level Computer Generated Forces
CD-ROM	Compact Disc - Read Only Memory.
CDRL	Contract Data Requirements List
CIG	Computer Image Generator

CFOR	Command Forces
Ckts	Circuits
CPU	Computer Processing Unit
C/SSR	Cost/Schedule Status Report
DBBL	Dismounted Battlespace Battle Lab
DO	Delivery Order
DED	Dynamic Element Database
DI	Dismounted Infantry
DIS	Distributed Interactive Simulation
Div	Division
DMA	Defense Mapping Agency
DOS	Disk Operating System
DSBL	Depth and Simultaneous Attack Battle Lab
DSI	Defense Simulation Internet
ECI	Exhibit Crafts Inc.
FAA	Forward Assembly Area
FIRESTORM	Federation of Intelligence, Reconnaissance, Surveillance and Targeting, Operations, and Research Models
FAS	Feasibility Analysis Study
FSE	Fire Support Element
GES	Greyhound Exposition Services
GFE	Government Furnished Equipment
GFI	Government Furnished Information
HAI	Houston Associates, Inc
HQ	Headquarters
HVAC	Heating Ventilation Air Conditioning
IAW	In Accordance With
ID	Identification

IDO	IRIX Development Option
IDREN	Interim Defense Research Engineering Network
IG	Image Generator
IP	Internet Protocol
IPR	In-Progress Review
ISDN	Integrated Services Digital Network
ITSEC	Interservice/Industry Training Systems Education Conference
ITS	Image Technical Services
JVL	Joint Virtual Laboratory
Kbits	Kilobits
Kbps	Kilobit per second
Kbits/Sec	Kilobits per second
KVA	Kilo Volt-Ampere
LAM-TF	Louisiana Maneuvers - Task Force
LAN	Local Area Network
LANDSAT	Land Satellite
LHN	Long Haul Network
LMC	Lockheed-Martin Corp
LOE	Level of effort
Log	Logistics
LSTAT	Life Support for Trauma And Transport
LTTS	Loral Training and Technical Services
LWSE	Land Warrior Simulation Extension
LWTB	Land Warrior Test Bed
M1	Abrams tank
MAC	Macintosh
MMAI	MITRE ModSAF Appliqué Interface
MAX	Maximum

MB	MegaByte
Mb	Megabits
Mb/sec	Megabits per second
MCS	Maneuver Control System
MDBIC	Missile Defense Battle Integration Center
MHZ	Mega Hertz
MICOM	Missile Command
MLRS	Multiple-Launch Rocket System
MM3V	Mobile Medical Mentoring Vehicle
ModSAF	Modular Semi-Automated Forces
MRCI	Modular Reconfigurable C4I Interface
MPRS	Mission Planning Rehearsal System
MSAC	Medical Situational Awareness and Control
MSI	Multi-Spectral Imagery
NAI/TAI	Names Area of Interest/Target Area of Interest
NATO	North Atlantic Treaty Organization
NEMA	National Electrical Manufacturers Association
NFS	Network File System
NPGS	Naval Post-Graduate School
NPSNET	Naval Post-Graduate School Network
NTC	National Training Center
OCs	Observers/Controllers
ODIN	Extension of the SIMNET SAF
OPFOR	Operational Forces
OSF	Operational Support Facility
OTW	Out The Window
PC	Personal Computer
PDU	Protocol Data Unit

PMCAAN	Program Manager, Combined Arms Assessment Network
PMO	Program Management Office
PMR	Program Management Review
POC	Point of Contact
PSM	Personnel Status Monitor
PVD	Plan View Display
RDA	Research Development & Acquisition
Res	Resolution
RF	Radio Frequency
RTM	Run Time Manager
SAF	Semi-Automated Forces
SAFOR	Semi-Automated Forces
SAT	Satellite; short for Satellite Command
SATCOM	Satellite Command
SCSI	Small Computer Standard Interface
sec	Seconds
SGI	Silicon Graphics, Inc.
SHAPE	Supreme Headquarters Allied Powers Europe
SIK	Sikorsky Aircraft Company
Sim	Simulator
SIMITAR	Simulation In Training for Advanced Readiness
SIMM	Single Integrated Memory Module
SIMNET	Simulation Network
SME	Subject Matter Expert
SOF	Special Operations Force
STRICOM	Simulation Training and Instrumentation Command
SVS	Soldier Visualization System
SWH	Sheraton Washington Hotel

T1	Digital T-carrier service
TBD	To Be Determined
TDY	Temporary Duty
TEL	Transporter/Erector/Launcher
TEMO	Training, Exercise & Military Operations
TI	Texas Instruments
TIES	Terrain Information Extraction System
TOC	Tactical Operations Center
TR	Technical Report
TRANSCOM	U.S. Army Transportation Command
TSIU	Tactical Simulation Interface Unit
UAV	Unmanned air Vehicle
UDLP	United Defense Limited Partnership
USACOM	U.S. Army Command
USAF	United States Air Force
VCR	Video Camera Recorder
VHMS	Vehicle Health Monitoring System
VME	Virtual Memory Extension
VP	Virtual Prototype