

**ADVANCED DISTRIBUTED
SIMULATION TECHNOLOGY II
(ADST II)
CCTT/BICEP (DO #0087) 4TH BCT SUPPORT
CDRL AB01
EXERCISE REPORT**

30 October 1998



For:

United States Army
Simulation, Training, and Instrumentation Command
12350 Research Parkway
Orlando, Florida 32826-3224

By:

Science Applications International
Corporation
12479 Research Parkway
Orlando, FL 32826-3248

Lockheed Martin
Information Systems Company
12506 Lake Underhill Road
Orlando, FL 32825



LOCKHEED MARTIN



19981229 021

REPORT DOCUMENTATION PAGE

Form Approved
OMB No. 074-0188

Reporting burden for this collection of information is estimated to average 1 hour per response, including the time for reviewing instructions, searching existing data sources, gathering and reviewing the data needed, and completing and reviewing this collection of information. Send comments regarding this burden estimate or any other aspect of this collection of information, including suggestions for reducing this burden to Washington Headquarters Services, Directorate for Information Operations and Reports, 1215 Jefferson Davis Highway, Suite 1204, Arlington, VA 22202-4302, and to the Office of Management and Budget, Paperwork Reduction Project (0704-0188), Washington, DC 20503

1. AGENCY USE ONLY (Leave blank)		2. REPORT DATE 30 Oct 1998	3. REPORT TYPE AND DATES COVERED Excercise Report	
4. TITLE AND SUBTITLE Advanced Distributed Simulation Technology II (ADST II) CCTT/BICEP 4 th BCT Support CDRL AB01 Exercise Report			5. FUNDING NUMBERS N61339-96-D-0002	
6. AUTHOR(S)				
7. PERFORMING ORGANIZATION NAME(S) AND ADDRESS(ES) Lockheed Martin Corporation Lockheed Martin Information Systems ADST II P.O. Box 780217 Orlando, FL 32878-0217			8. PERFORMING ORGANIZATION REPORT NUMBER ADST-II-CDRL-CCTT/BICEP-9800357	
9. SPONSORING / MONITORING AGENCY NAME(S) AND ADDRESS(ES) NAWCTSD/STRICOM 12350 Research Parkway Orlando, FL 32826-3324			10. SPONSORING / MONITORING AGENCY REPORT NUMBER	
11. SUPPLEMENTARY NOTES				
12a. DISTRIBUTION / AVAILABILITY STATEMENT A - Approved for public release; Distribution unlimited			12b. DISTRIBUTION CODE	
13. ABSTRACT (Maximum 200 Words) The 4 th BCT Training Exercise support was conducted during the period 6-24 July 1998 at the Close Combat Tactical Trainer (CCTT) facility, Ft. Hood, TX. The exercise was sponsored by the Directorate of Training, Doctrine and Simulation (DOTDS), U.S. Army Aviation Center, Fort Rucker, AL. The training exercise utilized virtual simulation (CCTT and BICEP) integrated with a notional tactical command and control network to provide training for 4 th BCT task force. A notional AVTOC was integrated on a tactical LAN. A DIS LAN consisted of manned simulators (ground and air elements) and computer generated forces. The two LANs were connected via the Tactical Simulation Interface Unit (TSIU). Scenarios were utilized to exercise the ground elements, aircrews, and command and control processes. The virtual stations included the Aviation Reconfigurable Manned Simulator (ARMS) proof of principle device and follow-on units (BICEP), the CCTT modules (tanks, and fighting vehicles). This exercise report addresses the simulation, tactical, and communications networks developed to support the integrated exercises and lessons learned. This document does not address the performance of the 4 th BCT Task Force during the exercise.				
14. SUBJECT TERMS ADST-II, STRICOM, BICEP, CCTT			15. NUMBER OF PAGES	
			16. PRICE CODE	
17. SECURITY CLASSIFICATION OF REPORT Unclassified	18. SECURITY CLASSIFICATION OF THIS PAGE Unclassified	19. SECURITY CLASSIFICATION OF ABSTRACT Unclassified	20. LIMITATION OF ABSTRACT UL	

Report Documentation Page	1. Report No.	2.	3. Recipient's Accession No.
4. Title and Subtitle: ADST II CCTT/BICEP DO (#0087) 4 th BCT Support Exercise Report		5. Report Date: 10/29/98	
7. Author(s) John B. Abernathy		8. Performing Organization Rept. No. ADST II-CDRL-CCTT/BICEP- 9800357	
9. Performing Organization Name and Address Lockheed Martin Corporation ADST II 12506 Lake Underhill Road Orlando, FL 32825		10. Project/task/Work Unit No.	
12. Sponsoring Organization Name and Address NAWCTSD/STRICOM 12350 Research Parkway Orlando, FL 32826-3224		11. Contract(C) or Grant(G) No. (C) N61339-96-D-0002 (G)	
15. Supplementary Notes		13. Type of Report & Period Covered Exercise Report	
16. Abstract (Limit 200 words) The 4 th BCT Training Exercise support was conducted during the period 6 – 24 July 1998 at the Close Combat Tactical Trainer (CCTT) facility, Ft. Hood, TX. The exercise was sponsored by the Directorate of Training, Doctrine and Simulation (DOTDS), U. S. Army Aviation Center, Fort Rucker, AL. The training exercise utilized virtual simulation (CCTT and BICEP) integrated with a notional tactical command and control network to provide training for 4 th BCT task force. A notional AVTOC was integrated on a tactical LAN. A DIS LAN consisted of manned simulators (ground and air elements) and computer generated forces. The two LANs were connected via the Tactical Simulation Interface Unit (TSIU). Scenarios were utilized to exercise the ground elements, aircrews, and command and control processes. The virtual stations included the Aviation Reconfigurable Manned Simulator (ARMS) proof of principle device and follow-on units (BICEP), the CCTT modules (tanks, and fighting vehicles). This exercise report addresses the simulation, tactical, and communications networks developed to support the integrated exercises and lessons learned. This document does not address the performance of the 4 th BCT Task Force during the exercise.		14.	
17. Document Analysis			
<p>a. Descriptors BICEP; CCTT; Virtual Simulation; Reconfigurable simulators; Command and Control; C2; C4I; Collective task training</p> <p>b. Identifiers/Open -Ended Terms</p> <p>c. COSATI Field/Group</p>			
18. Availability Statement A - Approved for public release; distribution is unlimited		19. Security Class (This Report) UNC	21. No. of Pages 39
		20. Security Class (This Page) UNC	22. Price

Table of Contents

1.	INTRODUCTION	1
1.1	PURPOSE.....	1
1.2	CONTRACT OVERVIEW	1
1.3	4 TH BCT TRAINING EXERCISE OVERVIEW	1
2.	APPLICABLE DOCUMENTS	1
2.1	GOVERNMENT	1
2.2	NON-GOVERNMENT	1
3.	SYSTEMS DESCRIPTION	2
3.1	SYSTEM CONFIGURATION AND LAYOUT.....	2
3.1.1	<i>Tactical Network Systems Description</i>	6
3.1.1.1	All Source Analysis System (ASAS).....	6
3.1.1.2	Maneuver Control System (MCS)	6
3.1.1.3	Forward Area Air Defense Engagement Operations (FAADEO)	6
3.1.1.4	Air and Missile Defense Warning System (AMDWS)	6
3.1.1.5	Advanced Field Artillery Tactical Data Systems (AFATDS).....	6
3.1.1.6	Unmanned Aerial Vehicle (UAV).....	6
3.1.2	<i>Distributed Interactive Simulation (DIS) Network Systems Description</i>	6
3.1.2.1	Reconfigurable Tactical Trainers (RTT) (Devices #3, #4, and #5).....	7
3.1.2.2	Stealth	7
3.1.2.3	Data Logger (SIMULYZER).....	7
3.1.2.7	After Action Review	8
3.1.2.8	Advanced Simulation Technologies incorporated (ASTi) Radio Simulation	8
3.1.3	<i>Tactical Simulation Interface Unit (TSIU)</i>	8
3.1.4	<i>Command, Control, Communications, Computers, and Information (C4I)</i>	8
3.1.5	<i>Software Baseline</i>	8
3.2	DATABASE AND SCENARIO DEVELOPMENT.....	9
4.	INTEGRATION AND TEST PLAN	10
4.1	INTEGRATION AND TEST STRATEGY	10
4.2	INTEGRATION AND TEST SCHEDULE.....	11
4.2.1	<i>Schedule</i>	11
5.	CONDUCT OF THE EXERCISES	11
6.	OBSERVATIONS AND LESSONS LEARNED	12
7.	CONCLUSION	12
8.	ACRONYMS	12

LIST OF FIGURES

FIGURE 1 - FT. HOOD CCTT BICEP FACILITY LAYOUT2
FIGURE 2 - NETWORK ARCHITECTURE3

LIST OF TABLES

TABLE 1 – SIMULATORS AVAILABLE4
TABLE 2 – CCTT NETWORK IP ADDRESSES5
TABLE 3 - SIMEX II/DAWE SOFTWARE BASELINE9
TABLE 4 – 4TH BCT SIMULATION TRAINING EXERCISE DTX II MISSIONS10

APPENDIXES

APPENDIX A - CCTT/BICEP GFE.....15
APPENDIX B – ORDER OF BATTLE & SIMULATION ENUMERATION.....16
APPENDIX C – OBSERVATIONS & LESSONS LEARNED23
APPENDIX D - CCTT/BICEP INTERACTION CAPABILITY ASSESSMENT.....26

EXECUTIVE SUMMARY

The 4th BCT Training Exercise support was conducted during the period 6 – 24 July 1998 at the Close Combat Tactical Trainer (CCTT) facility, Ft. Hood, TX. The exercise was sponsored by the Directorate of Training, Doctrine and Simulation (DOTDS), U. S. Army Aviation Center, Fort Rucker, AL. The training exercise utilized virtual simulation (CCTT and BICEP) integrated with a notional tactical command and control network to provide training for 4th BCT task force. A notional AVTOC was integrated on a tactical LAN. A DIS LAN consisted of manned simulators (ground and air elements) and computer generated forces. The two LANs were connected via the Tactical Simulation Interface Unit (TSIU). Scenarios were utilized to exercise the ground elements, aircrews, and command and control processes. The virtual stations included the Aviation Reconfigurable Manned Simulator (ARMS) proof of principle device and follow-on units (BICEP), the CCTT modules (tanks, and fighting vehicles). This exercise report addresses the simulation, tactical, and communications networks developed to support the integrated exercises and lessons learned.

The previous BICEP exercise at Ft. Hood (ADST-II-CDRL-BICEP-9700467A) provided the architectural framework for the tactical and simulation LANs. The original configuration was modified to add CCTT functionality through a gateway. Engineering integration was performed at the CCTT Lab in Orlando. However, due to time constraints, only partial integration was performed at the Orlando facility during a five day period prior to deployment to Ft. Hood, TX. Government Furnished Equipment (GFE) and Government Furnished Information (GFI) for the tactical network was provided by DOTDS and by the Central Technology Support Facility (CTSF) at Fort Hood, Texas. The installation of the Army Airborne Command and Control System Maneuver Control System (MCS) was performed at Ft. Hood, TX. CCTT is a fully self-contained collection of training devices, control stations, semi automated forces and after action review stations. The CCTT elements and the BICEP elements were connected through a DIS gateway. This document does not address the performance of the 4th BCT Task Force during the training exercise.

1. INTRODUCTION

1.1 Purpose

The purpose of this exercise report is to document the ADST II effort, which supported the CCTT/BICEP DO (#0087) and specifically capture the exercise network configurations, observations, and lessons learned. This document does not address the operational effectiveness of the various systems or specific results of the exercise.

1.2 Contract Overview

CCTT/BICEP 4th BCT support was performed as DO #0087 under the Lockheed Martin Corporation (LMC) ADST II contract with STRICOM. The DO contract required LMC to integrate the two simulations into a single exercise and support training of the 4th BCT at Ft. Hood. The effort was to provide as much capability as possible within restricted budget and schedule constraints. A gateway was selected as the best approach to join the two simulations.

1.3 4th BCT Training Exercise Overview.

The purpose of the 4th BCT Training Exercise was twofold: (1) support a training and mission rehearsal function for the combined arms elements of 4th BCT, and (2) demonstrate the simulated environment's ability to stimulate the digital tactical command and control system. Specific elements included manned simulators rounded out with Modular Semi-Automated Forces (ModSAF) and CCTT SAF. A gateway connected the simulated world to the tactical world, which stimulated elements of the Army Tactical Command and Control Systems (ATCCS). Information was taken from the simulated environment's protocol data units (PDU's) and transformed into Variable Message Format (VMF) messages which were then passed to appropriate elements in the ATCCS suite of equipment. Another gateway was used to transform from the CCTT protocol to the BICEP protocol. The gateway also performed a one-way ground clamping function to make sure ground based elements appeared correctly in the BICEP visual displays.

2. APPLICABLE DOCUMENTS

2.1 Government

ADST II Statement of Work for the Close Combat Tactical Trainer (CCTT) and Battlespace Integrated Concept Emulation Program Test Cell (BICEP) Training Exercise Support Delivery Order, AMSTI-98-W039 20 May 1998.

2.2 Non-Government

None

3. Systems Description

3.1 System Configuration and Layout

The AVTB supported the integration of a partial AVTOC (-), with its tactical network as well as ModSAF, the Aviation Reconfigurable Manned Simulator (ARMS) Proof of Principle (PoP) device, Advanced Simulation Technologies, inc. (ASTi) radio models for the DIS network, and an After Action Review (AAR) area. The BICEP was in a trailer and was positioned next to the CCTT building. The two simulations were joined through a pair of gateways, the first for radio traffic and the second for all remaining PDU traffic. Figure 1 depicts the physical layout of the facilities. Figure 2 depicts the network architecture and Table 1 lists the Simulators available for the exercise. Table 2 lists the CCTT network Internet Protocol (IP) addresses used during the 4th BCT Exercise. Appendix A identifies the GFE used for the exercise at Ft. Hood, TX.

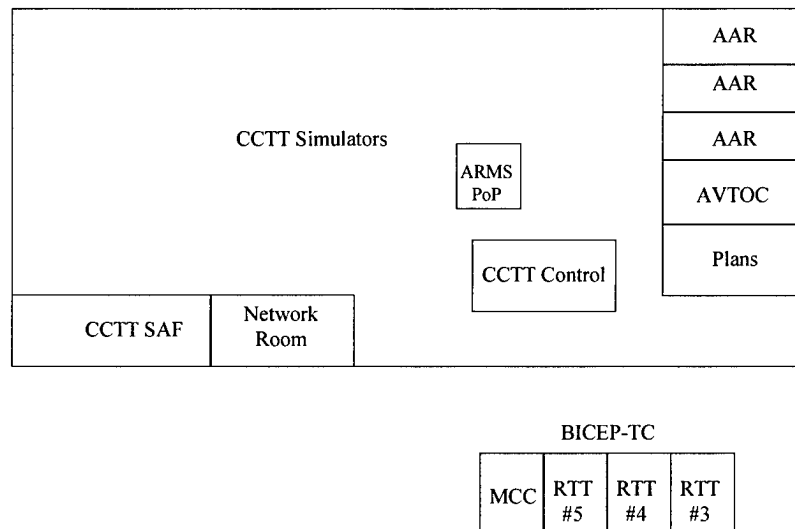

Figure 1 - Ft. Hood CCTT/BICEP Facility Layout

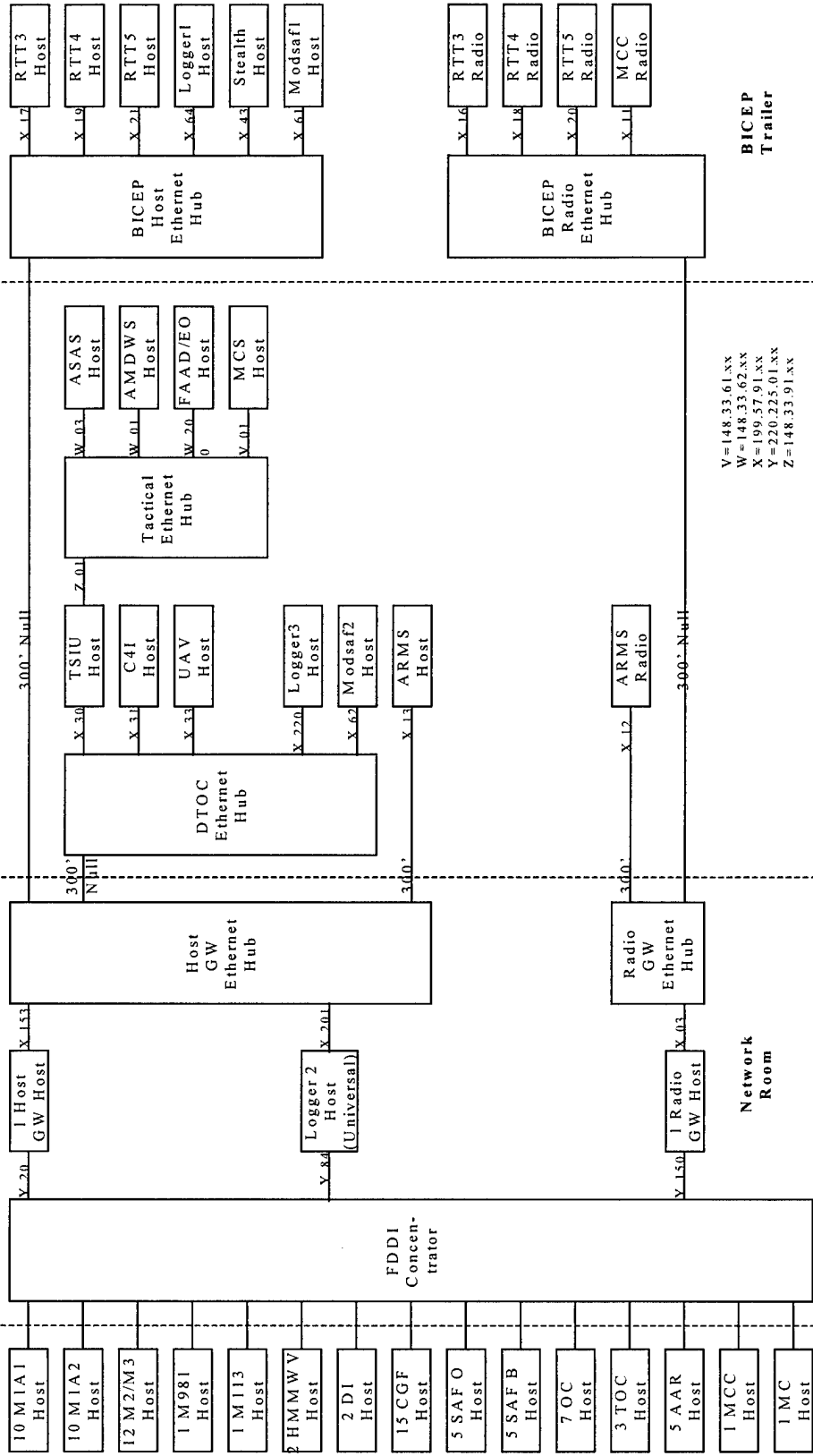

Figure 2 - Network Architecture

Table 1 – Simulators Available

<p>CCTT Simulators:</p> <p>10 M1A1 (4 crew members) 10 M1A2 (4 crew members) (will not be utilized for this exercise) 12 M2/M3 (3 crew members) 2 HMMWV (2 crew members) (If TACAIR used, 1 required for AF) 2 Dismounted Infantry 1 M981 FIST-V (3 crew members) 1 M113A3 (2-3 crew members)</p>	<p>CCTT TOC Workstations:</p> <p>Combat Engineering Support (CES) WS Fire Support Element (FSE) WS Tactical Air Control Party (TACP) WS (AF) Higher Hqs (2 radios)</p>
<p>CCTT Supporting Operations Center:</p> <p>Combat Trains Command Post (CTCP) WS (refueling/rearming--not usually manned) Unit Maintenance Collection Point (UMCP) WS (vehicle maintenance--not usually manned) Fire Direction Center (FDC) WS (mortars) Field Artillery Battalion TOC (FABTOC) WS</p>	<p>AVCATT/A PoP Simulators:</p> <p>3 Cockpits Reconfigurable to OH-58 and AH-64 (Interoperable with CCTT.) 1 Cockpit Reconfigurable to OH-58, AH-64, and UH-60 (Utilized for UH-60 missions only.)</p>

Table 2 – CCTT Network IP Addresses

Item	IP Address	Item	IP Address
MC	220.225.1. 2	G-1	220.225.1. 27
MCC	220.225.1. 1	G-2	220.225.1. 38
		G-3	220.225.1. 39
AAR-1	220.225.1. 3	M981	220.225.1. 40
AAR-2	220.225.1. 4		
AAR-3	220.225.1. 5	DI-1	220.225.1. 77
AAR-4	220.225.1. 6	DI-2	220.225.1. 78
AAR-5	220.225.1. 7	DI-3	220.225.1. 79
		DI-4	220.225.1. 80
A-1	220.225.1. 8	DI-5	220.225.1. 81
A-2	220.225.1. 9	DI-6	220.225.1. 82
A-3	220.225.1. 10		
		OC-1	220.225.1. 54
B-1	220.225.1. 11	OC-2	220.225.1. 55
B-2	220.225.1. 12	OC-3	220.225.1. 56
B-3	220.225.1. 13	OC-4	220.225.1. 57
B-6	220.225.1. 18	OC-5	220.225.1. 58
B-7	220.225.1. 19		
		TOC-1	220.225.1. 59
C-1	220.225.1. 14	TOC-2	220.225.1. 60
C-2	220.225.1. 15	TOC-3	220.225.1. 61
C-3	220.225.1. 16		
C-4	220.225.1. 20	SAF-1	220.225.1. 44
C-5	220.225.1. 21	SAF-2	220.225.1. 45
C-6	220.225.1. 22	SAF-3	220.225.1. 46
C-7	220.225.1. 23	SAF-4	220.225.1. 47
		SAF-5	220.225.1. 48
D-1	220.225.1. 17	SAF-6	220.225.1. 49
D-2	220.225.1. 28	SAF-7	220.225.1. 50
D-3	220.225.1. 29	SAF-8	220.225.1. 51
D-4	220.225.1. 24	SAF-9	220.225.1. 52
D-5	220.225.1. 25	SAF-10	220.225.1. 53
D-6	220.225.1. 26		
D-7	220.225.1. 27	CGF-1	220.225.1. 62
		CGF-2	220.225.1. 63
E-1	220.225.1. 30	CGF-3	220.225.1. 64
E-2	220.225.1. 31	CGF-4	220.225.1. 65
E-3	220.225.1. 32	CGF-5	220.225.1. 66
E-4	220.225.1. 33	CGF-6	220.225.1. 67
E-7	220.225.1. 42	CGF-7	220.225.1. 68
		CGF-8	220.225.1. 69
F-1	220.225.1. 34	CGF-9	220.225.1. 70
F-2	220.225.1. 35	CGF-10	220.225.1. 71
F-3	220.225.1. 36		
M113	220.225.1. 41	LOGGER	220.225.1. 84
F-7	220.225.1. 43		

3.1.1 Tactical Network Systems Description

The tactical network supported the ATCCS systems listed below. The ATCCS systems were integrated on one LAN using 10-base-T Ethernet cable. The following is a brief description of the tactical systems.

3.1.1.1 All Source Analysis System (ASAS)

ASAS serves as the primary system for conducting Intelligence Preparation of the Battlefield (IPB) for all echelons and for updating the intelligence picture of the battlefield during the mission. For the BICEP facility, one ASAS system was integrated via the tactical LAN.

3.1.1.2 Maneuver Control System (MCS)

The MCS serves as the focal point for the ATCCS. MCS depicts the maneuver Battlefield Functional Area (BFA) and serves as the integration point for all BFA systems. For the BICEP facility, one MCS was integrated via the tactical LAN.

3.1.1.3 Forward Area Air Defense Engagement Operations (FAADEO)

The FAAD system provided an overview of the area air defense picture. The FAAD system normally takes information from Air Force, Navy, and other national assets to formulate the common air picture. This information is typically transmitted over the Enhanced Position Location Reporting System (EPLRS) throughout the FAAD network. However, for this application, it was driven by the EADSIM. The FAAD system was located in the AVTOC.

3.1.1.4 Air and Missile Defense Warning System (AMDWS)

The AMDWS is a wide area integrated view of the battle space. It was stimulated by ASAS and MCS ATCCS inputs.

3.1.1.5 Advanced Field Artillery Tactical Data Systems (AFATDS)

AFATDS aspects were managed by the Battlemaster at the CCTT SAF workstation.

3.1.1.6 Unmanned Aerial Vehicle (UAV)

The UAV was included to introduce the commanders to the concepts of extended range reconnaissance and fire mission control.

3.1.2 Distributed Interactive Simulation (DIS) Network Systems Description

The following systems operated on the DIS network during the exercise. BICEP operated on DIS version 2.04 throughout the exercise. CCTT used DIS 2.04r, an extended version that has functions peculiar to CCTT. The gateway filtered the PDUs and converted from a fiber network to a 10 BaseT Ethernet. The simulated environment on the Ethernet side passed through the TSIU and served as the stimulus for the command and control systems for the exercise.

3.1.2.1 Reconfigurable Tactical Trainers (RTT) (Devices #3, #4, and #5)

The RTTs are a series that reflect the continued evolution of the ARMS device into a more supportable system. The basic operations remain the same. However, device #2 has a large screen display system for OTW graphics. It does not use a HMD system for the crew members. Devices #3 and #4 have advanced to HMDs for both crew members. Device #3 and #4 also have a new computer configuration that reduces the overall "footprint" and a more sophisticated flight model. All continue to operate on the DIS 2.04 protocol.

3.1.2.2 Stealth

The BICEP Stealth gives the Observer/Controller (O/C) personnel a "window" into the virtual battlefield, allowing them to make covert observations of the action occurring during the scenario. In addition, through the use of the data logger, the Stealth gives observers and analysts an AAR capability. The Stealth is a visual display platform that consists of a PVD (Plan View Display), various input devices, and a video display that provides the operator with a panoramic view of the battlefield.

The Stealth permits the controller to fly around the virtual battlefield and view the simulation without interfering with the action. The features of the Stealth allow the observer to survey the virtual battlefield from a variety of different perspectives, including:

- a. Tethered View - Allows the user to attach unnoticed to any vehicle on the virtual battlefield.
- b. Mimic View - Places the user in any vehicle on the virtual battlefield and provides the same view as the vehicle commander.
- c. Orbit View - Allows the operator to remain attached to any vehicle on the virtual battlefield and to rotate 360° about that vehicle, while still maintaining the vehicle as a center point of view.
- d. Free Fly Mode - Permits independent three-dimensional (3-D) movement anywhere in the virtual battlefield.

3.1.2.3 Data Logger (SIMULYZER)

The Data Logger is an asset that captures the network traffic and places the data packets on a disk file. The Data Logger performs the following functions:

- a. Packet Recording - Receives packets from the DIS network, adds time stamps, and then writes to disk.
- b. Packet Playback - Packets from a recorded exercise can be transmitted in real time or faster than real time. The Data Logger can also suspend playback (freeze time) and skip backward or forward to a designated point in time. The logger can be controlled directly from the keyboard or remotely from the PVD. Playback is visible to any device on the network (PVD, Stealth Vehicle, a vehicle simulator, etc.).

- c. Copying or Converting - Files are copied to another file, which can be on the same or a different medium; and files from the older version of the Data Logger can be converted to a format compatible with the current version of the Data Logger.

For the 4th BCT exercise, two and sometimes three data loggers were employed to capture the exercises. Information was captured on the CCTT side of the gateway as well as on the BICEP side. Because the radio traffic was separated out, the CCTT side had a more complete set of information.

3.1.2.7 After Action Review

The AAR suite provided the capability to display the exercises and provided 3-D stealth and PVD views. The AAR provided tools for analysis and report generation. There were three AARs in the exercise. One CCTT AAR was used by the ground element, a second was used by the air element and a third was available in the TOC area.

3.1.2.8 Advanced Simulation Technologies incorporated (ASTi) Radio Simulation

The ASTi Digital Audio Communication System (DACS) is a commercial off-the-shelf radio product that provides digital voice communication. The ASTi DACS utilizes DIS PDUs to simulate the radio sound environment. Air to ground communications were simulated through a SINCGARS radio model that included line-of-sight and range propagation effects. Communications plans tailored to specific training objectives and missions were published daily.

3.1.3 Tactical Simulation Interface Unit (TSIU)

The TSIU, provided the bridge between the tactical LAN and the DIS LAN. The TSIU takes UDP (User Data Protocol) formatted input from varying DIS simulations and outputs standard USMTF (United States Message Transfer Format) messages to specific ATCCS systems.

3.1.4 Command, Control, Communications, Computers, and Information (C4I)

The C4I simulation is used to add realism to the C4I elements of the battle space. For example, it was used as a source of AWACS (Airborne Warning And Control System) and JSTARS (Joint Surveillance And Targeting Attack Radar System) information. It was also a source of digital intelligence messages.

3.1.5 Software Baseline

The 4th BCT exercise utilized equipment from various vendors. Table 3 documents the version of the software that was used on the various workstations/simulators.

Table 3 - SIMEX II/DAWE Software Baseline

Exercise Component	Platform	Operating Sys	Application Software	Version
Stealth	PC	Windows 95	META VR	1.3
Data Logger	SGI Indigo2	IRIX 6.2	SIMULYZER	1.5
ModSAF	DEC Alpha 500	Ultrix 4.x	ModSAF	3.0
EADSIM	SGI Indigo2	IRIX 5.3		
MCS	SUN Sparc 20	Solaris 2.4	ABCSS**	2.04
ASAS	SUN Sparc 20	Solaris 2.4	ABCSS**	3.1
FAAD EO	SUN Sparc 20	Solaris 2.4	ABCCS**	3.1
AFATDS	SUN Sparc 20	Solaris 2.4	ABCCS**	3.1
AMDWS	SUN Sparc 20	Solaris 2.4	ABCCS**	3.1.1
TSIU *	SUN Sparc 20	Solaris 2.4	TSIU	5.0
C4I *	SUN Sparc 20	Solaris 2.4	C4I	3.1
UAV *	SGI Indigo II	IRIX 5.3	VR LINK	2.45
PVD *	SGI Extreme	IRIX 5.3	VR LINK	2.43
Data Logger *	SUN Sparc 10	Solaris 2.4	Data Logger	2.45
C2I	SGI Indigo II	IRIX 5.3 NFS		
Pop ARMS Device	PC (host) and Onyx		Reconfigurable - AH64A, OH58D and UH60	
AWC-C2	SGI-Indigo	IRIX 5.3	AWC-ITEMS C2	3.13

* CRC Equipment

** ABCSS - Army Battle Command

System Software

3.2 Database and Scenario Development

A new BICEP version of the NTC terrain database was used to support the 4th BCT exercise. This database was reasonably correlated with the CCTT P2 database. As previously mentioned, the gateway used a one way ground clamping to keep ground based objects on the ground in the BICEP visuals. The reverse was not provided so aircraft could occasionally appear to go under the ground and then reemerge. The database was derived from a common S1000 representation and converted into ModSAF CTDB (Compressed Terrain Data Base) format as well as various Multigen variations to fit the various user configurations. USAAVNC (DOTDS), in conjunction with planning staff from 4th BCT and CCTT, provided scenario development and the order of battle (Appendix B). The training missions were taken from the overall plan shown in Table 4.

Table 4 – 4th BCT Simulation Training Exercise DTX II Missions

Mission	1-4	1-10 Cav		1-67	C/2-4	TOC Requirements
	Avn	Air	Grnd	AR	Avn	
Deep Attack	X				X	2 TOCs (Atk Bn/Bde)
Movement to Contact	X	X	X			3 TOCs (Atk Bn/Cav Sqdn/Bde)
Screen/Guard		X	X		X	2 TOCs (Cav Sqdn/Bde)
Penetration/Exploitation	X			X		3 TOCs (Atk Bn/AR Bn/Bde)
Defend	X	X	X	X	X	Day 1: 2 TOCs (Cav Sqdn/Bde) Day 2: 3 TOCs (Cav Sqdn/AR Bn/Bde) Day 3: 3 TOCs (Atk Bn/AR Bn/Bde)

4. Integration and Test Plan

4.1 Integration and Test Strategy

The installation, checkout and integration plan was based on a priority scheme, that is, equipment was off-loaded from the truck and installed in a pre-determined order. Test and checkout of individual systems (e.g. AVTOC, BICEP, and CCTT simulators) was performed in a standalone mode (not connected to the main network) until such time that the overall integration effort was ready to accept that equipment for network integration. The main network refers to the final facility network. Local networks were set-up to test multiple components of individual systems. Individual systems had to be ready for integration into the main network when called for in the schedule.

Equipment was installed in the CCTT facility at Ft. Hood in the following order:

1. Ethernet wiring
2. AVTOC (MCS, ASAS, AMDWS, FAAD EO, AWC-C2, TSIU, C4I)

3. Gateways for CCTT/BICEP PDU traffic

4. Gateway for ASTI Servers and communications connections

As soon as equipment was installed in the facility, it was to be powered up and tested in a standalone mode to insure proper operation in preparation for network integration.

4.2 *Integration and Test Schedule*

The schedules were as follows:

4.2.1 Schedule

Monday July 6, 1998

Equipment arrives at Ft. Hood.

Tuesday July 7, 1998

Install equipment.

Begin standalone checkout of equipment as soon as it is installed and powered up.

Radio integration begins.

Wednesday July 8, 1998

Test and checkout of installed equipment continues.

Train-up of operators in simulators.

Thursday July 9, 1998

ATCSS software installation and checkout begins.

Begin network integration, ARMS PoP device, BICEP, ModSAF, and Stealth with CCTT equipment.

Train-up of operators in simulators.

Friday July 10 - 24, 1998

Exercises daily

Site Closes on 24th.

5. Conduct of the Exercises

The training exercises were conducted over an eleven-day period 10-24 July 1998. The 4th BCT Attack Helicopter elements received familiarization training with the BICEP devices and the Tank and fighting vehicle elements received training in the CCTT modules. Mission rehearsal

exercises were conducted for ground elements and aviation elements both as separate players and as a combined arms team. The crews were informed of the mission, given a tactical situation briefing and allowed to complete their own detailed approach to the specific mission. They performed the remainder of the mission in accordance with their unit operating procedures. The tactical staff monitored progress and collected data for the AAR.

6. Observations and Lessons Learned

Observations and lessons learned from the CCTT/BICEP integration effort are presented in Appendix C. The lessons learned are looked at from an administrative and engineering perspective. Several comments focus on the lack of time available for integration and testing due to various problems. The original schedule provided for an integration period followed by full-scale testing period. However, due to delays in delivery of the BICEP system and then an accelerated schedule to compensate, the integration period was condensed and there was no time to conduct adequate testing of the DIS networks or gateways prior to on-site efforts at Ft. Hood. The remaining observations were collected and reported previously as a separate finding. They are resubmitted here as Appendix D and as part of the overall lessons learned on interconnecting CCTT to BICEP.

7. Conclusion

The CCTT/BICEP architecture was extremely successful in supporting the 4th BCT Task Force during the training exercise. Despite a highly compressed schedule and budgetary constraints, the integration of the tactical systems with the virtual simulations was a success.

8. Acronyms

AAR	After Action Review
ADST	Advanced Distributed Simulation Technology
AFATDS	Advanced Field Artillery Tactical Data System
AMDWS	Air and Missile Defense Warning System
ARMS	Aviation Reconfigurable Manned Simulator
ASAS	All Source Analysis System
ASTi	Advanced Simulation Technologies, Inc
ATCCS	Army Tactical Command and Control Systems
AVTB	AViation Test Bed
AVTOC	AViation Tactical Operations Center
ATCCS	Army Tactical Command and Control System

ATX	Army Training eXercise
AWACS	Airborne Warning And Control System
BICEP	Battlespace Integrated Concept Emulation Program
C2	Command and Control
C4I	Command, Control, Communications, Computers, and Intelligence
CRC	Coleman Research Corporation
CTDB	Compressed Terrain DataBase
CTSF	Central Technology Support Facility
DACS	Digital Audio Communication System
DAWE	Division Advanced Warfighting Experiment
DIS	Distributed Interactive Simulation
DO	Delivery Order
DOTDS	Directorate for Training Doctrine and Simulation
DTX	Division Training eXercise
EADSIM	Extended Air Defense SIMulation
FAAD EO	Forward Area Air Defense Engagement Operations
GFE	Government Furnished Equipment
GFI	Government Furnished Information
HMD	Helmet-Mounted Display
IP	Internet Protocol
LAN	Local Area Network
LMC	Lockheed Martin Corporation
MCS	Maneuver Control System
ModSAF	Modular Semi-Automated Forces
OTW	Out-The-Window
PC	Personal Computer
PDU	Protocol Data Unit
PoP	Proof of Principle
PVD	Plan View Display

RTT	Reconfigurable Tactical Trainers
SGI	Silicon Graphics Industries
SIMEX	SIMulation EXercise
STRICOM	(US Army) Simulation Training and Instrumentation Command
TF	Task Force
TRADOC	TRaining and DOcumentaion Command
UAV	Unmanned Aerial Vehicle
USAAVNC	U. S. Army AViation Center
USMTF	United States Message Transfer Format
VMF	Variable Message Format
VV&A	Verification, Validation, and Accreditation

30 October 1998

APPENDIX A - CCTT/BICEP GFE

L/I	EQUIPMENT DESCRIPTION	QTY	NEED DATE	RETURN DATE	COMPONENT
1	SGI INDY workstation with 20 in color monitor, 96 Mb RAM, 1.0 Gb Disk Storage, and Irix v5.2 OS	1	10 June 98	2 July 98	Data Logger
2	SIMULYZER Software ver 1.5	1	10 June 98	2 July 98	Simulyzer Software
3	STEALTH SOFTWARE Mak Technologies	1	10 June 98	2 July 98	Stealth
4	ARMS POP DEVICE	1	10 June 98	31 July 98	ARMS POP Device
5	BICEP System	1	10 June 98	31 July 98	BICEP
6	PC CPU, MIC 20 in color monitor, CTX 128 b RAM, 2 Gb Disk Drive, CD ROM	1	10 June 98	2 July 98	ModSAF
7	HUBS - 10base T, each with 8 ports	3	10 June 98	31 July 98	BICEP
8	ASSOCIATED CABLING/HARDWARE	AS Req	10 June 98	31 July 98	BICEP to ARMS-POP
9	Power PC for CCTT Gateway FDDI card Ethernet card	1	10 June 98	31 July 98	

APPENDIX B – ORDER OF BATTLE & SIMULATION ENUMERATION

Blue Order of Battle										
Bde	Bn/Sqdn	Co/Trp	Entity	Simulator	Marking	UIC	Enumeration	Note		
4BCT										
		C/2-4	UH-60A	ARMS POP	BC24AVN	WAHDAA	1-2-225-21-2-1-0			
		D/1-44 ADA	HMMWV	SAF	BD144ADA	WOFZAA	1-1-225-6-1-1-0			
		31 CHEM	HMMWV	SAF	B31CHEM	WDGZAA	1-1-225-6-1-1-0			
		704 ORD	HMMWV	SAF	B704ORD	WODYAA	1-1-225-6-1-1-0			
		A/104 MI	HMMWV	SAF	BA104MI	WFACAA	1-1-225-6-1-1-0			
	4-42 FA		HMMWV	SAF	B442FA	WAFRFF	1-1-225-6-1-1-0			
		B/5-3 FA	HMMWV	SAF	BB53FA	WAKLFF	1-1-225-6-1-1-0			
	299 ENG		HMMWV	SAF	B299ENG	WAHGFF	1-1-225-6-1-1-0			
	404 ASB		HMMWV	SAF	B404ASB	WHAEFF	1-1-225-6-1-1-0			
	204 FSB		HMMWV	SAF	B204FSB	WAILFF	1-1-225-6-1-1-0			
		C/61 MED	HMMWV	SAF	BC61MED	WAKIAA	1-1-225-6-1-1-0			
	1-4 AHB				B14AVN					
		A/1-4	AH-64A	RTT	BA14AVN	WAGWAA	1-2-225-20-1-2-0			
		B/1-4	AH-64A	RTT	BB14AVN	WAGXAA	1-2-225-20-1-2-0			
		C/1-4	AH-64A	RTT	BC14AVN	WAGYAA	1-2-225-20-1-2-0			
	1-10 CAV				B110CAV					
		A/1-10	M2A2	M2A2	BA110CAV	WAKRAA	1-1-225-2-1-4-0			
		B/1-10	M2A2	M2A2	BB110CAV	WAKSAA	1-1-225-2-1-4-0			
		C/1-10	M2A2	M2A2	BC110CAV	WAKTAA	1-1-225-2-1-4-0			
		D/1-10	OH-58D	RTT	BD110CAV	WAKUAA	1-2-225-24-2-1-0			
		E/1-10	OH-58D	RTT	BE110CAV	WAKVAA	1-2-225-24-2-1-0			
	1-67 AR				B167AR					
		A/1-67	M1A1	M1A1	BA167AR	WAFDAA	1-1-225-1-1-2-0			

Blue Order of Battle (Cont.)

Bde	Bn/Sqdn	Co/Trp	Entity	Simulator	Marking	UIC	Enumeration	Note
		B1-67	M2A2	M2A2	BB167INF	WAFEEA	1-1-225-2-1-4-0	
		C/1-67	M1A1	M1A1	BC167AR	WAFFAA	1-1-225-1-1-2-0	
		A/588 ENG	HMMWV	SAF	BA588ENG	WAHLAA	1-1-225-6-1-1-0	

Blue Entities

Bde	Bn/Sqdn	Co/Trp	Entity	Simulator	Marking	UIC	Enumeration	Note
			A-10	SAF			1-2-225-2-4-1-0	
			M109	SAF			1-1-225-4-3-1-0	
			M978	SAF			1-1-225-7-19-2-0	
			M35A2	SAF			1-1-225-7-1-6-0	
			M3	SAF			1-1-225-2-1-6-0	
			M113A2	SAF			1-1-225-2-3-1-0	
			DI	SAF			3-1-225-1-52-6-0	
			UAV	SAF			1-2-225-50-4-0-0	
			DIG TOC				1-2-225-8-4-2-0	

Red Order of Battle

Div	Rgt	Bn/Sqdn	Co/Trp	Entity	Simulator	Marking	UIC	Enumeration	Note
1st CAA									
12 MRD									
	121 MRR					R121RGTM			
	122 MRR					R122RGTM			
	123 MRR					R123RGTM			
	120 TR					R120RGTK			
	12 DIV ART RGT					R112RGTART			
13 MRD									
	131 MRR					R131RGTM			
	132 MRR					R132RGTM			
	133 MRR					R133RGTM			

Red Order of Battle (Cont.)

Div	Rgt	Bn/Sqdn	Co/Trp	Entity	Simulator	Marking	UIC	Enumeration	Note
	130 TR					R130RGTTK			
	13 DIV ART RGT					R113RGTTART			
45 TD									
	451 TR					R451RGTTK			
	452 TR					R452RGTTK			
	453 TR					R453RGTTK			
	450 MRR					R450RGTMR			
	45 DIV ART RGT					R145RGTTART			
2nd CAA									
24 MRD									
	241 MRR					R241RGTMR			
	242 MRR					R242RGTMR			
	243 MRR					R243RGTMR			
	240 TR					R240RGTTK			
	24 DIV ART RGT					R124RGTTART			
25 MRD									
	251 MRR					R251RGTMR			
	252 MRR					R252RGTMR			
	253 MRR					R253RGTMR			
	250 TR					R250RGTTK			
	25 DIV ART RGT					R125RGTTART			
50 TD									
	551 TR					R551RGTTK			
	552 TR					R552RGTTK			
	553 TR					R553RGTTK			
	550 MRR					R550RGTMR			
	50 DIV ART RGT					R155RGTTART			

Red Entities

Div	Rgt	Bn/Sqdn	Co/Trp	Entity	Simulator	Marking	UIC	Enumeration	Note
				HIND	SAF			1-2-222-20-2-1-0	
				2S1	SAF			1-1-222-4-2-2-0	
				ZIL131	SAF			1-1-222-7-4-0-0	
				SA-9	SAF			1-1-222-4-20-0-0	
				2S6	SAF			1-1-222-4-22-0-0	
				ZSU-23-4	SAF			1-1-222-4-18-0-0	
				T-72	SAF			1-1-222-1-2-2-0	
				BTR-80	SAF			1-1-222-2-13-1-0	
				BMP-2	SAF			1-1-222-2-2-1-0	
				BRDM-2	SAF			1-1-222-2-4-3-0	
				SA-16	SAF			3-1-222-1-232-1-0	
				DI	SAF			3-1-222-1-237-6-0	
				DI	SAF			3-1-222-1-205-1-0	
				URAL 375C	SAF			1-1-222-7-9-1-0	
				URAL 375F	SAF			1-1-222-7-9-2-0	
		Mech Bn		BMP-2	SAF	R1MRBN		1-1-222-2-2-1-0	
		Mech Bn		BMP-2	SAF	R2MRBN		1-1-222-2-2-1-0	
		Mech Bn CP		BMP-2	SAF	R1MRBNCP		1-1-222-2-2-1-0	
			Mech Co CP	BMP-2	SAF	R1MRCOCP		1-1-222-2-2-1-0	
			Mech Co CP	BMP-2	SAF	R2MRCOCP		1-1-222-2-2-1-0	
			Mech Pltn	BMP-2	SAF	R1MRPL		1-1-222-2-2-1-0	
			Mech Pltn	BMP-2	SAF	R2MRPL		1-1-222-2-2-1-0	
			Mech Pltn	BMP-2	SAF	R3MRPL		1-1-222-2-2-1-0	
			Mech Pltn	BMP-2	SAF	R4MRPL		1-1-222-2-2-1-0	
			Mech Pltn	BMP-2	SAF	R5MRPL		1-1-222-2-2-1-0	
			Mech Pltn	BMP-2	SAF	R6MRPL		1-1-222-2-2-1-0	
		Tank Bn		T-72 (T-80)	SAF	R1TKBN		1-1-222-1-2-2-0	
		Tank Bn		T-72 (T-80)	SAF	R2TKBN		1-1-222-1-2-2-0	

Red Entities (Cont.)

Div	Rgt	Bn/Sqdn	Co/Trp	Entity	Simulator	Marking	UIC	Enumeration	Note
			Tank Co	T-72 (T-80)	SAF	R1TKCO		1-1-222-1-2-2-0	
			Tank Co	T-72 (T-80)	SAF	R2TKCO		1-1-222-1-2-2-0	
			Rgt Recon Pltn	BRDM-2	SAF	R1RRP		1-1-222-2-4-3-0	
			Rgt Recon Pltn	BRDM-2	SAF	R2RRP		1-1-222-2-4-3-0	
			CRP	BMP-2	SAF	R1CRP		1-1-222-2-2-1-0	
			FSE	T-72 (T-80)	SAF	R1FSE		1-1-222-1-2-2-0	
		AGMB		T-72 (T-80)	SAF	R1AGMB		1-1-222-1-2-2-0	
		Air Def Bn		SA-9	SAF	RIADBN		1-1-222-4-20-0-0	

Munitions			
Model	Munition	Enumeration	Note
A-10	MAVERICK (AGM-65)	2-2-225-1-4-0	
	30mm (GAU-8A)	2-9-225-2-3-1	
AH-64A	HELLFIRE (LR)	2-2-225-1-3-4-0	
	2.75 FFAR	2-9-225-2-21-0-0	
	30 mm (M789HEDP)	2-9-225-2-3-1-0	
OH-58D	HELLFIRE (LR)	2-2-225-1-3-4-0	
	2.75 FFAR	2-9-225-2-21-0-0	
	.50 CAL (M33)	2-8-225-2-5-2-0	
HIND	SPIRAL	2-2-222-1-8-0-0	
	30mm (ATHE)	2-2-222-2-2-0-0	
M1A1	M456A1	2-2-225-2-10-4-0	
	M392A2	2-2-225-2-10-3-0	
	M59 (7.62 Ball)	2-8-225-2-2-7-0	
M2/M3	TOW (BGM-71)	2-2-225-1-1-1-0	
	M919 (25mm)	2-2-225-2-3-3-0	
	M792 (25mm)	2-2-225-2-3-7-0	
M109	M107HE	2-9-225-2-14-2-0	
DI	M855	2-8-225-2-1-5-0	
	M59 (7.62 Ball)	2-8-225-2-2-7-0	
BRDM-2	14.5mm	2-1-222-2-2-1-0	
	USSRD	2-8-222-2-2-2-0	

Munitions (Cont.)			
Model	Munition	Enumeration	Note
BTR-80	14.5mm	2-1-222-2-2-1-0	
BMP-2	SPANDREL 30mm (HE)	2-2-222-1-7-0-0 2-1-222-2-6-2-0	
	USSRD	2-8-222-2-2-2-0	
	SA-18	2-1-222-1-30-0-0	
ZSU-23-4	23mm AP	2-1-222-2-3-2-0	
2S1			
2S6	SA-19 30mm (HE)	2-1-222-1-31-0-0 2-1-222-2-6-2-0	
SA9	GASKIN	2-1-222-1-21-0-0	
SA-16	NEEDLE	2-1-222-1-28-0-0	
T-72	125 HEAT 125 HE FRAG 125 SABOT 12.7mm MG	2-2-222-2-18-0-0 2-2-222-2-11-3-0 2-2-222-2-11-0-0 2-8-222-2-1-0-0	
	SONGSTER	2-2-222-1-10-0-0	

APPENDIX C – OBSERVATIONS & LESSONS LEARNED

Observation #1

The UDO information was not completely assimilated by the contractor team.

Discussion #1

The unilateral delivery order was a confusing activity that had to be combined with an existing DO in order to get the program completed. The separation of activities made understanding the assigned tasks difficult and complicated the accounting. The planning documents drew heavily from the DAWE previously conducted at Ft. Hood. The experience provided insights into the aviation command and control process and provided a strong framework for the development of the BICEP architecture. However, connecting to CCTT covered new territory and the previous experience was insufficient as a complete source and its value overestimated.

Lesson Learned #1

Even when previous exercises are available as models, it is imperative that all aspects of the current plan be analyzed for impact and completeness.

Observation #2

There needs to be an explicit integration plan with realistic risk assessment and mitigation included.

Discussion #2

There were internal (LMIS) relationships that had to be evolved during this DO execution and no specific technical approach plans were published. Controlling costs became an extremely detailed and difficult aspect of working the tasks. Different organizations were attempting to coordinate in areas in which they had not previously worked together. After some searching for technical leadership, it was assigned to the Lead from CCTT. Because the period of performance was very short, it was found to be imperative that we have coordination meetings at least once each day. The team seemed to respond best if there was a single individual performing as a coordinator/decision maker during the integration phase. Steve Farrow provided leadership in this area.

Lesson Learned #2

Make a detailed plan, have frequent meetings during integration, and use a single point coordinator.

Observation #3

Extra overtime was not planned for during the integration period.

Discussion #3

The original integration planned called for 8 hour work days during the integration period. However, with the compressed schedule for this exercise, it quickly became apparent that even longer days would be required along with working through weekends.

Lesson Learned #3

Extra overtime support is usually necessary to support a mid to high level integration effort.

Observation #4

Scenario development was not completed until immediately prior to the exercises.

Discussion #4

The original plan for the exercise called for the scenario to be provided 45 days prior to the exercise by DOTDS. However, the completed scenarios were not provided until a day prior to the exercise. The delay in scenario development created problems in terms of the specific number and types of entities to be used during the exercise. This was a particular problem for CCTT. Fortunately, the daily exercises were derivatives of the same basic forces and entities and the flexibility and professional skill of the support staff completed all exercises on time.

Lesson Learned #4

The scenario is a critical part of the exercise. If the scenario is not ready for release, at least an approved entity list must be provided as a basis for conducting integration testing.

Observation #5

Overcoming corporate resistance to a preferred solution and technical approach are more likely to require longer to negotiate.

Discussion #5

A contractor negotiating from a "reluctant participant" position can be difficult. He had a strong position against the technical approach, he had his own agenda, and did not seem to feel any pressure to support the solution recommended. In our situation, we were running against a very short timeline and needed to award subcontracts so we could get back to the Government with our solution to the problem they had given to the ADST II team.

Lesson Learned #5

There are technical and political hurdles to some procurement. The subcontractor may be very hard to close.

Observation #6

Verification, Validation, and Accreditation (VV&A) are important.

Discussion #6

Although there was no contractual requirement for VV&A, it is necessary to run a self checking VV&A just to get organized and ready to operate. Unfortunately, the lack of a formal effort made the process vulnerable to incomplete analysis and checking. There were several instances where information was confusing or wrong simply because there was no formal process to verify the model being used prior to its introduction. Demonstrations and to some extent loosely constructed training events can succeed without formal validation of the system. However, it was apparent that there would have been fewer instances of interruption and late night analysis if there had been a separate effort to check on the information being used in the exercise.

Lesson Learned #6

All ADST II delivery orders should have a VV&A task.

Observation #7

Numerous telephones are required to facilitate installation and integration of equipment

Discussion #7

Invariably there are requirements to coordinate with remote sources during the installation and integration period. There were no telephone lines into the BICEP trailer. Resourceful engineers resorted to expensive wireless communication over cell phone connections in order to complete their tasks on schedule.

Lesson Learned #7

Install telephone communications first.

Observation #8

All operator positions need a back up.

Discussion #8

There was no back up for the Battlemaster at Ft. Hood. Either the support staff has to be cross-trained to cover shortages or there have to be additional personnel assigned to make sure that contingencies are covered.

Lesson Learned #8

Cover personnel contingencies with cross training.

APPENDIX D - CCTT/BICEP INTERACTION CAPABILITY ASSESSMENT

Item	CCTT	BICEP	Notes
Terrain Data Base (TDB)	Primary 2	National Training Center (NTC)	Two separate TDBs caused some problems. BICEP side of system used NTC and CCTT side used P2.
Network Layer translations	Single network	Multiple networks	CCTT uses a single network with multicast protocol and BICEP uses multiple Ethernet networks to separate traffic.
Multicast/Broadcast (MC/BC)	MC or BC	BC	CCTT- GW for host traffic & ASTi router for radio traffic.
Protocol Data Unit (PDU) Bundle	Bundled	Single	CCTT-GW and ASTi router unbundled PDUs
FDDI/Ethernet	FDDI	Ethernet	CCTT-GW and ASTi router converted from FDDI to Ethernet (10 base T)
Network Time to Live	One unit	More than one unit	ASTi router had to adjust for this in order to pass traffic. BICEP can be in a wide area network.
SAF Internal-Talk	SEOD	ModSAF (Pocket Version)	CCTT-GW filtered out SEOD traffic. Can turn ModSAF radio transmissions off to lower network load.
Radio Communication	SINCGARs Secure voice, frequency hopping, CVSD only, range and terrain interference	ASTi Radio in each device & MCC. Clear comm by co-locating antenna. Have various radio	Used ASTi router to separate radio traffic from host PDU traffic. Set one radio in each RTT to a SINCGARS CCTT CVSD model configuration. This configuration allowed aircraft to talk to CCTT modules or Operations Centers. CCTT radios have to be attached to properly configured

Item	CCTT	BICEP	Notes
	<p>determination. Frequencies must be preloaded in scenario. Can not check radio until exercise is ready to run and then only with radios that have physical proximity.</p>	<p>models available. Can use Mu law as well as CVSD.</p>	<p>vehicles to allow them to talk from a correct terrain location. Could change frequencies in CCTT radios but would not have any effect unless frequency was in the comm plan. BICEP radio models had to be reconfigured to correspond to daily configuration change requirements. Stand a lone operations required a separate configuration since exercise driver changed from CCTT to BICEP MCC. CCTT radio model enforced full terrain interference and range model which was a factor that was new to BICEP operations where clear communications had been the norm. CCTT can not monitor VHF or UHF radio frequencies.</p>
<p>Ground Clamping</p>	<p>No</p>	<p>Yes</p>	<p>Used ground clamping in CCTT GW to provide a one way correction into BICEP. That is, CCTT objects were adjusted to BICEP terrain. "Z" values were replaced as coordinates passed through GW from CCTT to BICEP. BICEP objects seen in CCTT were still subject to floating or submerged operations.</p>
<p>Probability of kill (Pk) & Probability of hit (Ph)</p>	<p>Approved for CCTT</p>	<p>ModSAF 3.0 & 4.0</p>	<p>ModSAF can be adjusted if necessary. CCTT can not be adjusted because they have a controlled configuration. We did not adjust ModSAF values but did use Battlemaster intervention to increase damage when system indicated firepower and mobility kills but did not show damage. CCTT has more criteria than ModSAF so there was a mismatch in mapping kill condition given a hit.</p>
<p>Entity Enumerations</p>	<p>Fixed Tables</p>	<p>ModSAF & BICEP RTT Visuals are matched</p>	<p>Must be checked for entities played. BICEP can adjust if necessary. Started with AAAA list. Used GW to solve some of the enumeration differences. Dismounted Infantry in</p>

Item	CCTT	BICEP	Notes
			CCTT has many more enumerations than BICEP recognizes. Needed to map the multiple CCTT entities to a few BICEP entities and accept the differences from an aviation point of view.
Marking Field	Assigned automatically	Pre-assigned in scenario	Must be pre-assigned during scenario development. TSIU compares unit type with vehicle type during processing. CCTT GW transformed to ASCII file so that TSIU could read marking fields.
Model Reference	CG	CG	Although both reference the CG, appearance can be confusing. Models may have different values for descriptive information or may be related to "defelade" position assigned to CCTT entities. BICEP entities do not have a terrain slope adjustment to ground contact so parts of aircraft may appear underground when on ground.
SAF Performance Level	Variable	Variable	Set for "same" level. Adjusted both to lowest level of aggressiveness. CCTT SAF seemed to be able to kill ModSAF entities at very long ranges, even shooting through terrain.
Collision	Yes	Yes	Check all combinations during integration.
Data Recording & Play back	CCTT Logger & AAR Station	BICEP uses Simulyzer	CCTT bundles data and uses burst transmissions. BICEP can not handle the playback from CCTT. Simulyzer works very well for BICEP. Both can be run at the same time. Radio separated from remainder of PDUs. Therefore, playback from Simulyzer did not have radio traffic since both networks could not be recorded at the same time.
Power Requirements	As is	Van requires 2 each 480v, 60 Amp three	BICEP had to get cables. Had to get an electrician to connect upon arrival and disconnect at end. BICEP is now carrying

Item	CCTT	BICEP	Notes
FDDI/Ethernet connection	FDDI or Ethernet available at Concentrator & Ethernet available after GW.	Can accept either connection. FDDI will be more expensive and offers no real advantage in current configuration.	the cables and can connect to an appropriate source. Still requires an electrician if CCTT cable not available at each site.
Hellfire Missile Fly-Out	No	Yes	Set the two gateways in the CCTT Network room and ran two separate 10 base T Ethernet cables to trailer and ARMS PoP device inside building. Also ran Ethernet to TSIU which acted as a gateway to tactical network for TOC operations.
Air Defense Artillery (ADA)	No threat warning signal	ModSAF has: <ul style="list-style-type: none"> • ZSU-23-4 model that has radar signal that stimulates BICEP models. • 2S6 model that has a radar model that stimulates BICEP models. 	Should not be a problem. Have to test in CCTT, worked OK. Never completed satisfactorily from CCTT ADA. Emissions PDU's were not detected by BICEP. We suspect that it was related to terrain differences because LOS could not be established during checking, therefore it did not recognize emission. Played from ModSAF.
Field Artillery	Through FO/FDC SAF	Battlemaster operates ModSAF IAW voice requests.	A/G Arty net will allow BICEP A/C to talk directly with FDC. CCTT should be able to fire the missions for BICEP A/C. ModSAF artillery could not kill CCTT entities.
30mm Cannon and 50 cal MG	Enumeration	30mm on AH-64 & 50 cal on OH-58D.	Seemed to work sufficiently well.

Item	CCTT	BICEP	Notes
Maps & Grid Reference	MGRS	MGRS	Gateway solved the basic problem by acting as the translator. Made sure we had the same datum, map designations and grid zones. Used CCTT maps.
Start EX/ Stop EX/ End EX	From MCC	Voice Command from MCC	Had to use voice from BICEP MCC, relay from CCTT MCC during combined ops.
Pause EX/ Resume EX	Yes	Yes	ModSAF could be paused, BICEP A/C reacted to voice command from BM. Each cockpit had to hit freeze unless it was actually activated from ModSAF.
Time Sync	Exercise Time	Wall clock time	BICEP can adjust for day or night operations and can play lower visibility. We did not need to do this.
Smoke	Yes	Yes	Did not check this.
Chaff	No	Yes, BICEP can dispense from A/C.	Nothing reacts to BICEP generated chaff in current configuration.
IR Jammer	No	Yes, BICEP can play IR jammer on/off.	Nothing reacts to BICEP generated jamming at present time.
Laser Warning	No	Yes	Nothing reacts to BICEP generated laser warning or jamming at present time.
Laser Designator	Yes	Yes	Remote designation works between BICEP A/C. Need to see if Remote designation will work across sims. Also need to see if it will work from a ModSAF designator for an A/C and from an A/C designator for a MODSAF shooter. Did not check it with CCTT designators. BICEP was able to designate CCTT targets and get hits from a remote BICEP shooter.

Item	CCTT	BICEP	Notes
Rearm/refuel/ repair	YES	Not PDU transactions. Pilot performs own reload with reset. Procedure and scenario control time.	ModSAF can set-up FARP and BICEP crews can land at site but no PDU transactions are required.
After Action Review (AAR)	Full capability	Single VCR (VHS) playback tape of whatever was recorded during mission. Can select any of five sources for recording (3 sensors, Stealth, ModSAF PVD). Have to route the selection to appropriate display and recorder.	Simulizer will capture all PDU traffic (except radio transmissions) on Ethernet. It will play it back and we can watch PVD and Stealth and hear voices and sounds but will not be able to see what crew was looking at or hear their radio calls unless we happen to have selected the appropriate view for recording. Do not hear their radio calls under any circumstance using the BICEP AAR. When we used the CCTT AAR function, we had all information available for display and we had radio traffic as well.
Start-Up Procedures	Automated	Manual	CCTT must be on-line prior to initializing ASTi GW (radios) to prevent lock-up. ModSAF GW must be initialized after CCTT comes up or ModSAF will not see CCTT entities.
Dead Reckoning	Yes	Yes	Suspect that there was a problem with DR algorithms. CCTT manned module entities frequently zoomed ahead and back at inconsistent speeds during movements.
Network traffic volume	100 MBPS capacity on FDDI	10 MBPS capacity on each of two Ethernet	Separated radio traffic but did not attempt to join the two networks to really test operational capacity. Scenarios were

Item	CCTT	BICEP	Notes
		networks.	controlled to restrict traffic.
DIS Standard	2.04r	2.04	Extra elements of CCTT (2.04r) are lost in going across the gateway.