

ADVANCED DISTRIBUTED
SIMULATION TECHNOLOGY II
(ADST II)

AVIATION RECONFIGURABLE MANNED
SIMULATOR TEST CELL PROOF OF PRINCIPLE
CDRL AB01

SYSTEM DESCRIPTION



19981229 022

FOR: NAWCTSD/STRICOM
12350 Research Parkway
Orlando, FL 32826-3224
N61339-96-D-0002
DI-MISC-80711

BY: Lockheed Martin Corporation
Lockheed Martin Information Systems
ADST II
P.O. Box 780217
Orlando, FL 32878-0217

Distribution authorized to the Department of Defense and U.S. DoD contractors only (Administrative/ Operational Use), (21 November 1996).
Other requests shall be referred to: STRICOM (T Ferguson, Contracts, (407) 381-8943).

This document contains information that is proprietary to Reflectone, Inc. Use by the recipient of this document and information contained within this document is expressly restricted to the program identified by the document's title. By receipt of this document, recipient agrees not to: use this document or information therein for any other purposes, disclose any portions thereof in other documents without prior written permission of Reflectone, Inc.

REPORT DOCUMENTATION PAGEForm Approved
OMB No. 074-0188

Public reporting burden for this collection of information is estimated to average 1 hour per response, including the time for reviewing instructions, searching existing data sources, gathering and maintaining the data needed, and completing and reviewing this collection of information. Send comments regarding this burden estimate or any other aspect of this collection of information, including suggestions for reducing this burden to Washington Headquarters Services, Directorate for Information Operations and Reports, 1215 Jefferson Davis Highway, Suite 1204, Arlington, VA 22202-4302, and to the Office of Management and Budget, Paperwork Reduction Project (0704-0188), Washington, DC 20503

1. AGENCY USE ONLY (Leave blank)

2. REPORT DATE

16 Feb 1998

3. REPORT TYPE AND DATES COVERED

System Description

4. TITLE AND SUBTITLE

Advanced Distributed Simulation Technology II (ADST II)
Aviation Reconfigurable Manned Simulator Test Cell Proof of
Principle System Description

5. FUNDING NUMBERS

N61339-96-D-0002

6. AUTHOR(S)

7. PERFORMING ORGANIZATION NAME(S) AND ADDRESS(ES)

Lockheed Martin Corporation
Lockheed Martin Information Systems
ADST II
P.O. Box 780217
Orlando, FL 32878-0217

8. PERFORMING ORGANIZATION
REPORT NUMBER

ADST-II-CDRL-033R-9600411B

9. SPONSORING / MONITORING AGENCY NAME(S) AND ADDRESS(ES)

NAWCTSD/STRICOM
12350 Research Parkway
Orlando, FL 32826-3324

10. SPONSORING / MONITORING
AGENCY REPORT NUMBER

11. SUPPLEMENTARY NOTES

12a. DISTRIBUTION / AVAILABILITY STATEMENT

A - Approved for public release; Distribution unlimited

12b. DISTRIBUTION CODE

13. ABSTRACT (Maximum 200 Words)

This System Description provides a summary of the principle elements of the Aviation Reconfigurable Manned Simulator Test Cell (ARMS-TC) Proof of Principle device. The device was used as an evaluation tool in assessing fidelity requirements for an aviation element collective task trainer. The device can be configured as an UH-60 Blackhawk, OH-58D Kiowa Warrior, or an AH-64A Apache. The visual system is based on a Silicon Graphics, Inc. Infinite Reality image generator and includes both out the window monitors and a helmet mounted display capability. In addition, the visuals included head down and night vision goggle sensor views. The system includes nine personal computers as the computational capability. It also includes a control loading system to provide trim and pilot feel feed back. An aural cue system is used to provide sound and seat vibration cues for pilot stimulation. A digital radio communication system capability is included. The device is certified as DIS 2.04 compliant.

14. SUBJECT TERMS

ADST-II, STRICOM, ARMS, Aviation, Reconfigurable, Manned, Simulator

15. NUMBER OF PAGES

16. PRICE CODE

17. SECURITY CLASSIFICATION
OF REPORT

Unclassified

18. SECURITY CLASSIFICATION
OF THIS PAGE

Unclassified

19. SECURITY CLASSIFICATION
OF ABSTRACT

Unclassified

20. LIMITATION OF ABSTRACT

UL

Report Documentation Page	1. Report No. ADST-II-CDRL-033R-9600411B	2.	3. Recipient's Accession No.
4. Title and Subtitle Aviation Reconfigurable Manned Simulator Test Cell (ARMS-TC) Proof of Principle System Description		5. Report Date 2/16/98 6.	
7. Author(s) Reflectone, Inc.		8. Performing Organization Rept. No. MIM ARMS-TB-001R1	
9. Performing Organization Name and Address Lockheed Martin Corporation Lockheed Martin Information Systems ADST II P.O. Box 780217 Orlando, FL 32878-0217		10; Project/task/Work Unit No. D.O. 26 11. Contract(C) or Grant(G) No. (C)N61339-96-D-0002 (G)	
12. Sponsoring Organization Name and Address NAWCTSD/STRICOM 12350 Research Parkway Orlando, FL 32826-3224		13. Type of Report & Period Covered 14.	
15. Supplementary Notes This document contains information that is proprietary to Reflectone, Inc. Use by the recipient of this document and information contained within this document is expressly restricted to the program identified by the document's title. By receipt of this document, recipient agrees not to: use this document or information therein for any other purposes, disclose any portions thereof in other documents without prior written permission of Reflectone, Inc			
16. Abstract (Limit 200 words) This System Description provides a summary of the principle elements of the Aviation Reconfigurable Manned Simulator Test Cell (ARMS-TC) Proof of Principle device. The device was used as an evaluation tool in assessing fidelity requirements for an aviation element collective task trainer. The device can be configured as an UH-60 Blackhawk, OH-58D Kiowa Warrior, or an AH-64A Apache. The visual system is based on a Silicon Graphics, Inc. Infinite Reality image generator and includes both out the window monitors and a helmet mounted display capability. In addition, the visuals included head down and night vision goggle sensor views. The system includes nine personal computers as the computational capability. It also includes a control loading system to provide trim and pilot feel feed back. An aural cue system is used to provide sound and seat vibration cues for pilot stimulation. A digital radio communication system capability is included. The device is certified as DIS 2.04 compliant.			
17. Document Analysis a. Descriptors ARMS; Aviation; Reconfigurable; Manned; Simulator; b. Identifiers/Open -Ended Terms c. COSATI Field/Group			
18. Availability Statement D Distribution authorized to the Department of Defense and U.S. DoD contractors only (Administrative/ Operational Use), (21 November 1996). Other requests shall be referred to: STRICOM (T Ferguson, Contracts, (407) 381-8943).		19. Security Class (This Report) U	21. No. of Pages 74
		20. Security Class (This Page) U	22. Price

TABLE OF CONTENTS

1 INTRODUCTION	1
2 FUNCTIONAL DESCRIPTIONS.....	4
2.1 POWER DISTRIBUTION	4
2.1.1 Ac Distribution.....	4
2.1.2 Dc Distribution.....	5
2.1.3 Electrical Safety Systems	6
2.1.4 Lighting.....	7
2.1.5 Heat Detection.....	7
2.2 HOST COMPUTER AND I/O SYSTEMS	7
2.2.1 Host Computer.....	7
2.2.2 I/O System.....	9
2.2.2.1 DIO-96 Card	20
2.2.2.2 DIO-24 Card	21
2.2.2.3 ADIO1600 Card.....	22
2.2.2.4 ER- 16 Relay Module	22
2.2.2.5 Connector Blocks.....	23
2.2.2.6 Distribution Block	23
2.2.2.7 I/O Distribution Panel.....	23
2.3 VISUAL SYSTEM	24
2.3.1 Host PC/Image Generator	24
2.3.2 29" Color Displays	25
2.3.3 Helmet Mounted Display (HMD).....	27
2.3.4 HMD CRT Electronics Unit.....	29
2.3.4.1 Low Voltage Power Supply.....	30
2.3.4.2 CRT Bias Assembly.....	31
2.3.4.3 Rapid Retrace Assembly.....	31
2.3.4.4 Raster MCB	31
2.3.4.5 Dual Focus Power Supply	31
2.3.4.6 Horizontal and Vertical Deflection Amplifiers.....	31
2.3.4.7 Video Processor Assembly	32
2.3.4.8 High Voltage Power Supply	32
2.3.5 HMD Color Wheel Electronics Unit.....	32
2.3.6 Head Tracker.....	33
2.4 AURAL CUE/SEAT SHAKER SYSTEM.....	33
2.4.1 Vendor Equipment Description	33
2.4.2 Aural Cue System Description.....	34
2.4.2.1 Host Computer/Ethernet System.....	35
2.4.2.2 Aural Cue Computer/MIDI.....	37
2.4.2.3 Digital Audio Sampler.....	37
2.4.2.4 270 MB SCSI Disk Drive	38
2.4.2.5 Audio Power Amplifiers.....	38
2.4.2.6 Speaker System.....	39
2.4.3 Vibration System Description	39
2.5 CONTROL LOADING SYSTEM	45
2.5.1 Mechanical Assemblies.....	46
2.5.2 Controls Computer	46
2.5.2.1 I/O Cards.....	46
2.5.2.2 Bus-to-Bus Adaptor Cards.....	47

2.5.3 Torque Motors	47
2.5.4 Electrical System.....	47
2.5.4.1 Dc Power Supplies.....	47
2.5.4.2 PWM Amplifiers	47
2.5.5 Feedback Sensors	48
2.6 COCKPIT COMPONENTS/SYSTEMS	48
2.6.1 Graphic Panels	48
2.6.2 Instrument/Cockpit Management Display System	49
2.6.2.1 Instrument/Cockpit Management Pcs	49
2.6.2.2 Instrument Displays	49
2.6.2.3 Cockpit Management Display.....	50
2.6.2.4 Touchscreens	50
2.6.2.5 RGB/View Video Windowing System	51
2.6.3 Cockpit Special, Accessory, and Stowage Hardware	51
2.6.3.1 Stowage Compartments	51
2.6.3.2 Boarding/Egress Handles.....	51
2.6.3.3 HMD Fan Assembly	51
2.6.3.4 Grimes Lights	52
2.6.3.5 Keyboard Jack Assemblies	52
2.6.3.6 Recirculating Blower	52
2.7 NETWORK INTERFACE	52
2.7.1 Ethernet/DIS Interface.....	52
2.8 DIGITAL COMMUNICATION SYSTEM.....	54
2.9 SOFTWARE CONFIGURATION	55
2.9.1 Host PC.....	56
2.9.1.1 FORTRAN Modules:.....	56
2.9.1.2 DIS Modules:.....	60
2.9.1.3 "C" Modules:	61
2.9.1.4 Assembler modules:.....	61
2.9.1.5 Executable:	61
2.9.2 Instrument Display PCs	66
2.9.4 PDU Filter PC.....	66
2.9.5 Aural Cue PC.....	66
2.9.6 Control Loading PC	66
2.9.7 Communications PC.....	67
2.9.8 SGI Infinite Reality	67
2.10 SOFTWARE RESTORATION	67
2.10.1 PCs (Except Control Loading)	68
2.10.2 Control Loading PC	68
2.10.3 Image Generator.....	68

TABLE OF FIGURES

FIGURE 1. ARMS TEST BED, SYSTEM BLOCK DIAGRAM.....	3
FIGURE 2. I/O SYSTEM, BLOCK DIAGRAM.....	10
FIGURE 3. HELMET MOUNTED DISPLAY SYSTEM, BLOCK DIAGRAM.....	28
FIGURE 4. AURAL CUE/VIBRATION SYSTEMS, BLOCK DIAGRAM.....	36

LIST OF TABLES

TABLE 1. POWER SUPPLY CONFIGURATION.....	6
TABLE 2. UH-60 CONFIGURATION-SPECIFIC, INTERFACE SYSTEM ASSIGNMENTS	11
TABLE 3. OH-58D CONFIGURATION-SPECIFIC, INTERFACE SYSTEM ASSIGNMENTS	14
TABLE 4. AH-64 CONFIGURATION-SPECIFIC, INTERFACE SYSTEM ASSIGNMENTS	16
TABLE 5. ARMS-TC IMAGE GENERATOR CHANNELS	26
TABLE 6. VENDOR-SUPPLIED HARDWARE	34
TABLE 7. TEST BED INSTRUMENT SOUND FILES	41

SYSTEMS DESCRIPTION

1 INTRODUCTION

The ARMS-TB provides a unique platform to analyze the simulation and training fidelity requirements for future production of ARMS devices. In order to serve this function, various equipment/systems have been assembled and connected in a manner to produce a form of training consistent with the customer's requirements. The test bed incorporates components that support training through effective visual and instrument presentations, control loading, motion (vibration), communications, etc. Figure 1 represents the test bed's functional layout and the equipment used to provide simulation.

A HMD and supporting electronics package is provided as the Pilot's primary visual display. OTW monitors are also provided for both the Pilot and Copilot and a hand-held ORT display for the AH-64. In addition, the visual monitor has been configured as a repeater, i.e., displaying same view as Copilot OTW. Each type of display receives video from the SGI image generator and is selected for operation under control of the image generator and Host PC.

A generic control loading model is supplied with off-the-shelf vendor hardware to provide the control loading function. The controls Industrial Personal Computer (ILPC) communicates with the Host PC via the Ethernet network.

The instrument/cockpit management display system uses inputs received from individual PCs to display appropriate graphic presentations and/or image generator video on the provided displays. Sync combiners and RGB video overlay equipment is connected between the left and right monitors and their associated instrument PC's video outputs. This allows real-time video (from visual system) to be overlaid on top of the PC-generated graphical displays.

The aural cue/vibration system uses acoustic cues developed from the Digital Audio Sampler (using Host PC inputs) to develop both the audio and vibrations. Amplified signals are routed to the speaker system and seat shakers via dedicated amplifiers.

An off-the-shelf digital communications system is provided for the simulated Comm audio system. Connections (not shown) are provided for the Pilot, Copilot, and two observers. The Comm PC uses two Ethernet connections to support simulation requirements: one for the local system and one for the external DIS network. This provides a means of enabling or disabling communications locally, as well as, allowing external communications with other DIS connected

equipment/ entities. A dual cassette deck is connected to allow a record function for Pilot and Copilot Comm audio.

Test bed communications are routed between equipment using RS232, Ethernet, I/O, or reflective memory formats. An external system connection (other than Comm connection) is provided for the DIS network

A supplied power distribution system (not shown) provides power to all test bed components and ensures that power related safety functions are maintained. For system functional descriptions, refer to the following paragraphs.

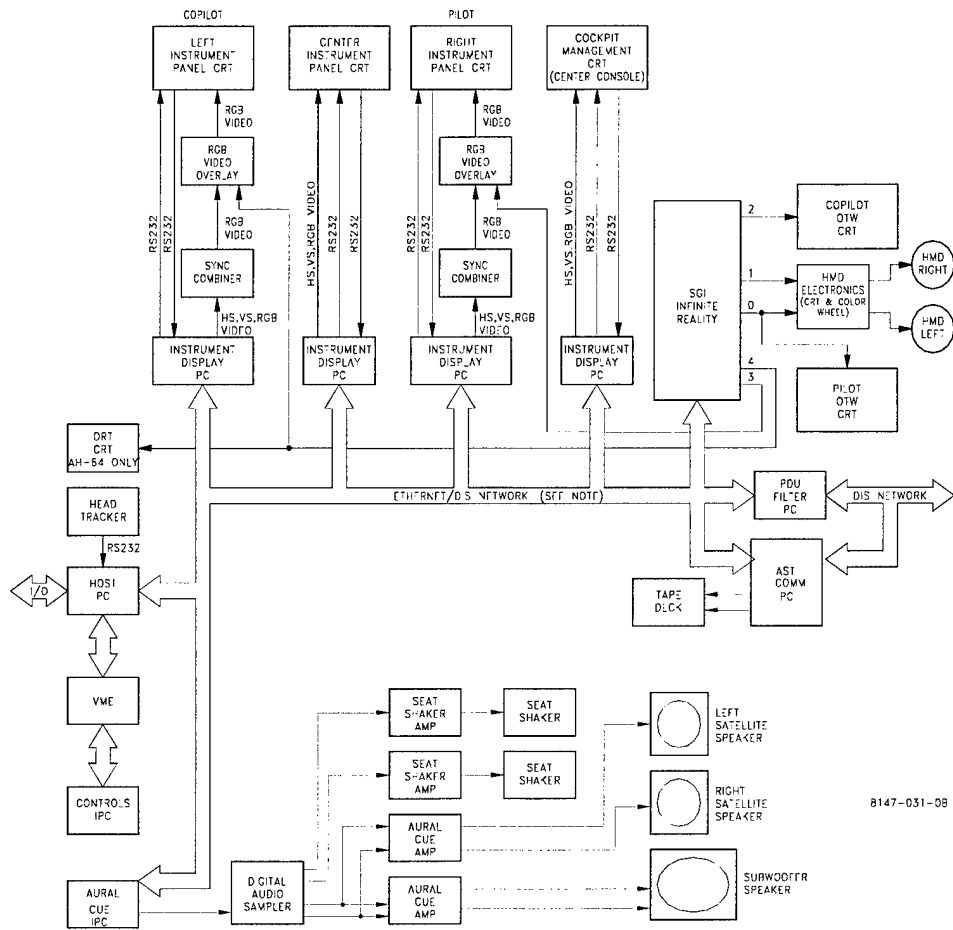

Note: Equipment Ethernet connections are routed via the Multiport Ethernet/IEEE Repeater unit (not shown). Some are routed directly to the multiple inputs on the unit, and other connections are daisy-chained together with a single input to the unit. Refer to paragraph 2.7.1

Figure 1. ARMS Test Bed, System Block Diagram

2 FUNCTIONAL DESCRIPTIONS

2.1 Power Distribution

The power distribution system consists of five individual systems: the ac power system, dc power system, electrical safety system, lighting system, and heat detection system. The ac distribution system accepts 115/230V, three-phase, 60 Hz facility power and distributes it to various locations on the test bed via an ac distribution panel assembly, and in some cases, the electronics cabinet I/O distribution panel. System dc power originates at the electronics cabinet and is distributed to various test bed components via a dc disconnect panel. Other dc power is produced by vendor equipment and not described in this manual. This would include items like monitors, VME chassis, PCs, RGB video windowing system, etc. For descriptions on internally generated dc power, refer to applicable vendor documentation. The test bed houses an emergency power off switch for both the Pilot and Copilot. When either switch is pressed, operational ac and dc power is removed from the test bed equipment and emergency lights illuminate for safety. General lighting is provided in the electronics cabinet for maintenance purposes. Emergency lighting is provided on top of the cabinet. Heat sensors are mounted in various enclosures for equipment protection.

2.1.1 Ac Distribution

Clean 115/230 Vac, three-phase, 60 Hz facility power is routed to the test bed ac distribution panel via a site local disconnect switch. The ac distribution panel assembly consists of three individual panels: load center panel A1 (left), ac control panel A2 (middle), and main C/B panel A3 (right). 115/230 Vac power enters the ac distribution panel assembly at main C/B panel A3 and is routed to both main C/B panel main circuit breaker CB 1 and to the ac control panel power monitoring circuits.

In normal operation, CB 1 is engaged (on) and three-phase power is routed to the load center circuit breakers (single or three-phase may be used by load center breakers) and to ac control panel status monitoring circuits. This main input power is protected by the surge arrester assembly located in the top-left corner of the ac control panel. The status monitoring circuits consist of a elapsed time meter, power on indicator, and input power fault indicator. When circuit breaker CB1 is engaged (on), phase A power is routed to the elapse time meter M1 and phase C power is routed to power on indicator DS 1. The meter moves in relation to time (hours) and the power on indicator illuminates green to indicate normal operation.

Prior to entering main circuit breaker CB 1, three-phase power is routed to the ac control panel power monitoring circuits. The power monitoring circuits consist of a transformer and power monitor assembly. Transformer T 1 uses phase A power to develop 24 Vac. The power monitor assembly monitors for undervoltage, loss of phase, and phase reversal, and reconfigures to produce the necessary signals to shut the system down should any of these conditions occur.

In normal operation, transformer T 1 steps down the power to 24 Vac and routes it to the power monitor internal relay connection via the emergency power off (EPO) switch and heat sensor circuits. The internal relay is energized anytime input three-phase power is normal. The monitor assembly cover contains a LED to indicate the status of voltage/relay circuit. With the relay energized, 24 Vac is then passed to the undervoltage coil on main circuit breaker CB 1. CB 1 stays engaged (on) as long as 24 Vac is kept on its under-voltage network.

If a facility power problem occurs, the power monitor detects this condition and deenergizes its internal relay. 24 Vac is removed from the main circuit breaker undervoltage network, causing CB 1 to trip off-line. In addition, 115 Vac is applied to light the red fault indicator on the ac control panel. After power is restored to normal, the circuit breaker can be reset by placing the control to the full off position, followed by full on position. Reset is possible only after 24 Vac is returned to CB 1 undervoltage network.

Three-phase power routed to the load center is distributed to equipment via one of thirteen circuit breakers (fifteen provided, two spare). These breakers handle either single or two-phase power, and carry protection ratings of 10, 15, 20, or 30 amps. For circuit breaker descriptions, refer to Chapter 2.

A facility earth ground is routed to the power distribution panel assembly control panel (6A2E1). All equipment enclosures (cockpit, electronics cabinet, and image generator cabinet) are then electrically connected to this point to provide the overall grounding system.

2.1.2 Dc Distribution

The test bed uses a single rack-mounted power supply assembly for all external dc requirements. The Lambda Modular Power System (LMPS) used is mounted in the electronics cabinet and contains five independent power supply assemblies: two LZS-150-1, two LZS-50-2, and a single LZS-250-3. These power supplies are adjusted/connected to provide the five required voltage levels: +5, -5, +12, +15, and +28 Vdc,

The LMPS selected is pre-configured for an ac input of 110 Vac and houses a metered front panel. The metered front panel displays the voltage and current of the installed power supplies. It also monitors the performance of the supplies with limits initially set by Reflectone. MIN VOLTS, MAX VOLTS, and MAX CURR adjustments were set and act as the programmed limits. If limits are ever violated, the ARMED audible alarm sounds, the front panel display, indicates the faulty supply, and a flashing LED indicates which limit was violated.

Table 1 identifies all characteristics applicable for each internal supply. A power supply rack front panel label also displays information relating to each supply.

Table 1. Power Supply Configuration

Power Supply No.	Output Voltage Level	Supply Part Number	MAX VOLTS Set Point	MIN VOLTS Set Point	MAX CURR Set Point
PS 1	+5.0 Vdc	LZS-150-1	5.50 Vdc	4.50 Vdc	20 Amps
PS 2	-5.0 Vdc	LZS-150-1	5.50 Vdc	4.50 Vdc	20 Amps
PS 3	+15.0 Vdc	LZS-50-2	15.7 Vdc	14.3 Vdc	4.0 Amps
PS 4	+12.0 Vdc	LZS-50-2	12.7 Vdc	11.3 Vdc	4.2 Amps
PS 5	+28.0 Vdc	LZS-250-3	29.0 Vdc	27.0 Vdc	5.0 Amps

All dc power is distributed to applicable equipment via a dc distribution panel (A24) located in the electronics cabinet. Power is routed through numerous breakers on the panel and on to equipment via terminal board assemblies. For circuit breaker and dc routing, refer to Table 2-14.

2.1.3 Electrical Safety Systems

The test bed contains two electrical items that are associated with power related safety. This includes two emergency power off (IEPO) switches and a battery supported light assembly.

EPO switches are provided on both the Pilot and Copilot side consoles. They are installed so that should emergency conditions arise, personnel seated in the cockpit have the capability to quickly remove operational power from the test bed. Both switches are electrically connected in series with the power monitoring circuits on the ac distribution panel and the heat sensor assemblies mounted on the cockpit base frame and electronics cabinet. When a switch is pressed, 24 Vac is momentarily removed from the undervoltage network of main C/B panel circuit breaker CB 1.

This condition causes the breaker to trip, thereby removing operational power from the test bed. Only operational power is removed. Voltage is still present in portions of the ac distribution panel assembly.

Emergency lighting is provided at the top of the electronics cabinet. This off-the-shelf dual light assembly provides light to the test bed area should facility power be lost. The unit contains a battery charging system that trickle charges its internal battery as long as power is applied to the test bed. 115 Vac is routed directly to the unit from electrical connections provided at the I/O distribution panel (TB7). Battery life is untested but assumed to be sufficient for temporary power disruptions. Complete charge time (from dead battery) requires approximately seven days.

2.1.4 Lighting

General lighting is provided to support maintenance operations. Two off-the-shelf fluorescent light assemblies are mounted in each side of the dual electronics cabinet and electrically connected to an ac power strip. To turn either light on, simply reposition the power switch on the applicable unit.

Lighting is also provided in the form of Grimes lights mounted in the cockpit for both the Pilot (DS2) and Copilot (DS1). Electrical connections to the outboard consoles/lights are via the I/O distribution panel (TB4). The Grimes lights use 28 Vdc generated from the power supply rack assembly and routed to the cockpit via the dc distribution panel.

2.1.5 Heat Detection

The test bed houses two heat sensor assemblies: one in the electronics cabinet and one in the cockpit base frame. Both heat sensor assemblies are identical and contain elements that react to temperature. These elements are normally closed and pass 24 Vac to the power monitoring circuits. If the temperature in the applicable enclosure exceeds 110°F, the element opens, removing 24 Vac from the control circuits. This causes main circuit breaker CB 1 to trip, removing operational power from the test bed to protect equipment. When the temperature drops below 110°F, the element returns to the closed position, placing 24 Vac back on the control circuits. The main circuit breaker can be reset after 24 Vac returns.

2.2 Host Computer and I/O Systems

The following paragraphs provide a brief system description for the Host Computer and I/O systems. For detailed I/O hardware descriptions, refer to applicable vendor documentation.

2.2.1 Host Computer

The Host Computer consists of a 166 MHz, IBM-compatible personal computer (PC). It contains both standard PC related cards, as well as, specific application cards associated with test bed interface functions. The Host PC controls the real-time simulation through scheduling, processing, off loading, etc. data necessary for test bed operation. It serves as a central hub for all activities within the simulation and performs the primary modeling for the aircraft. Unique and shared models for aircraft navigation, weapon, and aircraft systems are run in the host to process and replicate parameters for simulation. Mode flags determine when common and unique software models are processed. Simulations are not complete and only certain functions are supported for this program.

To support the duties of the host, Reflectone-developed software is provided and written in assembly, FORTRAN, and C. Software switches identify which of the three supported aircraft configurations are currently active. The software is setup in a fixed frame executive which is

structured to support 1, 5, 10, 15, 20, 30, and 60 Hz tasks. Scheduling of the sub-bands is keyed off of a cycle frame counter.

The Host PC interfaces with each of the satellite systems through Ethernet transfers, reflective memory (Bit 3), PC-based I/O, or RS-232 formats.

The host interfaces with the visual system across an Ethernet linkage. A unique interface control block is transmitted to the SGI image generator for reporting ownership activities and tactical interactions. Upon receipt of an output transmission, the visual system also returns a unique interface control block of information for use by the host.

Head tracker information is passed via a RS-232 connection. When the test bed is operating in HMD mode, the serial interface is processed to issue commands to the head tracker system. In addition, reference angles are read in as the tracker follows pilot head movement. The interface runs at 115,500 bits/sec and is interfaced with the PC's standard COM1 port. Reference frame, hemisphere, and position/angle commands are issued to the head tracker, and mode reads are read into the host. Raw head tracker data is off loaded to the image generator.

A PC-based I/O system is used to communicate with cockpit operational controls and other test bed circuitry that require digital or analog inputs/outputs. The Host PC is configured with two ISA DIO cards and a single ISA ADIO card. DIO cards are used to transfer both digital inputs (DIs) and digital outputs (DOs). The ADIO card supports analog inputs (AIs) and analog outputs (AOs), with only AIs required for test bed operation. In addition, the ADIO card has the capability to handle digital inputs/outputs. This capability is not used in the present configuration. These cards are interfaced using a Reflectone-designed I/O program. No third party vendor interface routines are used.

The host contains a PC-style bus-to-bus adapter card that interfaces the control loading system (C/L) via a Shared Memory Link (SML). This card is one of four cards used in the test bed to provide the shared/reflective memory capability. The host has minimal authority for simulating the control systems of the three aircraft configurations. Friction levels, damping, and trim control are basic outputs from the system and force, velocity, and control positions are basic inputs.

There are four instrument display computers (includes cockpit management PC) that interface with the Host PC. These display PCs are running Windows NT applications that represent the cockpit instruments of the simulated aircraft configuration. Inputs from touch screen sensitive controls and outputs for display indications, are both communicated via Ethernet packets. Inputs are sent upon demand on a low update cycle. Outputs are transmitted at 20 Hz on a continual basis. The packet inputs and outputs are different based on the aircraft type being simulated.

The Host PC communicates with the aural cue/vibration systems (aural cue IPC) across the Ethernet network. At time of publication, only output traffic is generated since there are no inputs required from the aural cue IPC.

The test bed uses a network filter (PDU Filter PC) between the host and the outside network. This filter serves to filter out the host traffic (host, visual, display, and aural cue) that doesn't belong on a DIS network. It does allow needed information from the DIS to pass into the local network for processing. As far as the host is concerned, this computer is unknown with no interfacing requirements.

The Host PC interfaces with the Digital Communication System (DCS) system via the Ethernet network. When the host receives information on the Ethernet from selections made at the simulated Comm panels, the host routes this data on to the Comm PC (via Ethernet) so that it can perform the applicable function. The Comm simulation task is to merely interface simulated panel information to the remote Comm PC.

2.2.2 I/O System

The interface system (Figure 2.) provides the real-time input/output (I/O) interface between the Host PC and functional test bed cockpit switches and indicators. Three vendor supplied cards reside in the Host PC on the ISA bus: a DIO-96, DIO-24, and ADIO 1600. In addition, two connector blocks, a distribution block, single ER-16 relay module, and I/O driver software (Reflectone-developed) are also provided.

The National Instrument DIO cards provide for both digital input (DI) and digital output (DO) transfers, and are similar with the exception of bit size capability. In this configuration, the PC-DIO-96 card is used for digital inputs and the PC-DIO-24 card is used for both digital inputs and outputs. Connector blocks are used in conjunction with the PC-DIO-96 card to provide a means of changing cockpit-side discrete wiring to the ribbon cable format required by the card. They also provide a means of connecting the pull-up resistor networks required for all DIs. The relay module houses 16 SPDT relay assemblies and also provides terminal connections for non-relay required circuits for the PC-DIO-24 card. DOs are routed to the relay assemblies and DIs are connected to the 26-pin terminal connection.

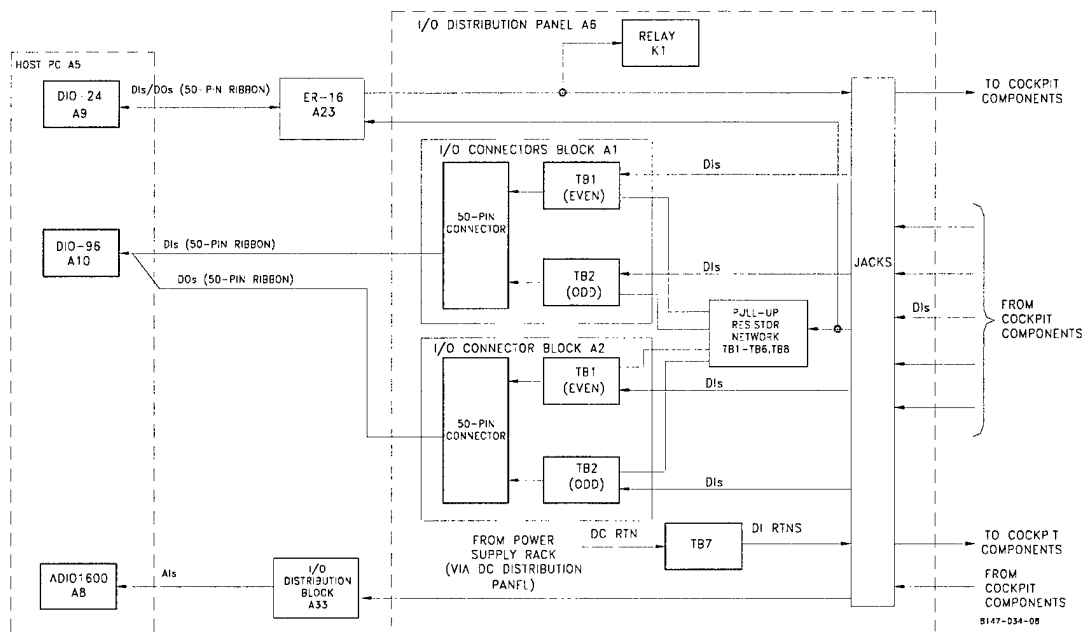

Figure 2. I/O System, Block Diagram

The Industrial Computer Source ADIO card is provided to handle analog input related I/O tasks associated with OH-58D and AH-64 simulation. A dedicated distribution block provides the means of changing cockpit-side discrete wiring to the connection required by the card. The ADIO card is capable of also performing digital I/O. This feature is currently not used in this configuration.

For a complete I/O assignment listing for each aircraft configuration, refer to Table 2 (UH-60 Table 3 (OH-58D), and Table 4 (AH-64). I/O assignments do not mean that the applicable function is operational.

Table 2. UH-60 Configuration-Specific, Interface System Assignments

<u>I/O</u> <u>Assigned</u>	<u>Description</u>	<u>System Print/Sheet</u>
<u>DIs</u>		
APC0	Not Used	7C827-00-04,1
APC1	Pilot Collective Grip Configuration Check	7C827-00-04,1
APC2	Pilot Collective Grip Search Light R S6	7C827-00-04,1
APC3	Pilot Collective Grip Search Light RETR S6	7C827-00-04,1
APC4	Pilot Collective Grip Search Light L S6	7C827-00-04,1
APC5	Pilot Collective Grip Search Light EXT S6	7C827-00-04,1
APC6	Pilot Collective Grip ENG RPM DECR S5	7C827-00-04,1
APC7	Pilot Collective Grip ENG RPM INC S5	7C827-00-04,1
BPA0	Pilot Collective Grip SVO OFF 2ND STG S4	7C827-00-04,1
BPA1	Pilot Collective Grip SVO OFF 1ST STG S4	7C827-00-04,1
BPA2	Pilot Collective Grip EN4ERG HOOK REL S2	7C827-00-04,1
BPA3	Pilot Collective Grip TRIM REL S3	7C827-00-04,1
BPA4	Pilot Collective Grip EMERG HOOK REL S2	7C827-00-04,1
BPA5	Pilot Collective Grip LDG LT OFF S1	7C827-00-04,1
BPA6	Pilot Collective Grip LDG LT ON S1	7C827-00-04,1
BPB1	Not Used	7C827-00-02,3
BPB2	Pilot Cyclic Grip Configuration Check	7C827-00-02,3
BPB3	Not Used	7C827-00-02,3
BPB4	Not Used	7C827-00-02,3
BPB5	Not Used	7C827-00-02,3
BPB6	Pilot Cyclic Grip I.C.S. S5	7C827-00-02,3
BPB7	Pilot Cyclic Grip RADIO S5	7C827-00-02,3
BPC0	Pilot Cyclic Grip STICK TRIM R S6	7C827-00-02,3
BPC1	Pilot Cyclic Grip TRIM REL S2	7C827-00-02,3
BPC2	Pilot Cyclic Grip STICK TRIM AFT S6	7C827-00-02,3
BPC3	Pilot Cyclic Grip STICK TRIM L S6	7C827-00-02,3
BPC4	Pilot Cyclic Grip STICK TRIM FWD S6	7C827-00-02,3
BPC5	Pilot Cyclic Grip CARGO REL S4	7C827-00-02,3
BPC6	Pilot Cyclic Grip GA S1	7C827-00-02,3
BPC7	Pilot Cyclic Grip PNL LTS S3	7C827-00-02,3

Table 2. UH-60 Configuration-Specific, Interface System Assignments (Cont)

<u>I/O Assigned</u>	<u>Description</u>	<u>System Print/Sheet</u>
<u>DIs</u>		
CPA4	Center Console Panel Active Switch S3	7C823-04-01, 3
CPA5	Center Console Panel Active Switch S2	7C823-04-01, 2
CPA6	Center Console Panel Active Switch S1	7C823-04-01, 1
CPC1	Not Used	7C827-00-05, 1
CPC2	Copilot Collective Grip Configuration Check	7C827-00-05, 1
CPC3	Copilot Collective Grip Search Light R S6	7C827-00-05, 1
CPC4	Copilot Collective Grip Search Light RETR S6	7C827-00-05, 1
CPC5	Copilot Collective Grip Search Light L S6	7C827-00-05, 1
CPC6	Copilot Collective Grip Search Light EXT S6	7C827-00-05, 1
CPC7	Copilot Collective Grip ENG RPM DECR S5	7C827-00-05, 1
DPA0	Copilot Collective Grip ENG RPM INC S5	7C827-00-05, 1
DPA1	Copilot Collective Grip SVO OFF 2ND STG S4	7C827-00-05, 1
DPA2	Copilot Collective Grip SVO OFF 1ST STG S4	7C827-00-05, 1
DPA3	Copilot Collective Grip SRCH LT STOW S3	7C827-00-05, 1
DPA4	Copilot Collective Grip SRCH LT ON S3	7C827-00-05, 1
DPA5	Copilot Collective Grip EMERG HOOK REL S2	7C827-00-05, 1
DPA6	Copilot Collective Grip LDG LT OFF S1	7C827-00-05, 1
DPA7	Copilot Collective Grip LDG LT ON S1	7C827-00-05, 1
DPB1	Not Used	7C827-00-03, 3
DPB2	Copilot Cyclic Grip Configuration Check	7C827-00-03, 3
DPB3	Not Used	7C827-00-03, 3
DPB4	Not Used	7C827-00-03, 3
DPB5	Not Used	7C827-00-03, 3
DPB6	Copilot Cyclic Grip I.C.S. S5	7C827-00-03, 3
DPB7	Copilot Cyclic Grip RADIO S5	7C827-00-03, 3

**Table 2. UH-60 Configuration-Specific, Interface
System Assignments (Cont)**

<u>I/O Assigned</u>	<u>Description</u>	<u>System Print/Sheet</u>
DIs (Cont)		
DPC0	Copilot Cyclic Grip STICK TRIM R S6	7C827-00-03, 3
DPC1	Copilot Cyclic Grip TRIM REL S2	7C827-00-03, 3
DPC2	Copilot Cyclic Grip STICK TRIM AFT S6	7C827-00-03, 3
DPC3	Copilot Cyclic Grip STICK TRIM L S6	7C827-00-03, 3
DPC4	Copilot Cyclic Grip STICK TRIM FWD S6	7C827-00-03, 3
DPC5	Copilot Cyclic Grip CARGO REL S4	7C827-00-03, 3
DPC6	Copilot Cyclic Grip GA S 1	7C827-00-03, 3
DPC7	Copilot Cyclic Grip PNL LTS S3	7C827-00-03, 3
DOs		
PA0	Center Console Panel Back Light DS1/DS2	7C823-04-01, 1
PA1	Center Console Panel Back Light DS3/DS4	7C823-04-01, 2
PA2	Center Console Panel Back Light DS5/DS6	7C823-04-01, 3

Table 3. OH-58D Configuration-Specific, Interface System Assignments

<u>I/O Assigned</u>	<u>Description</u>	<u>System Print/Sheet</u>
DIs		
APC0	Pilot Collective Grip Configuration Check	7C827-00-04, 3
APC1	Not Used	7C827-00-04, 3
APC2	Not Used	7C827-00-04, 3
APC3	Not Used	7C827-00-04, 3
APC4	Pilot Collective Grip TRIM REL S4	7C827-00-04, 3
APC5	Pilot Collective Grip CHAN SEL FREQ S3	7C827-00-04, 3
APC6	Pilot Collective Grip CHAN SEL DN S3	7C827-00-04, 3
APC7	Pilot Collective Grip CHAN SEL KYBD S3	7C827-00-04, 3
BPA0	Pilot Collective Grip CHAN SEL UP 3	7C827-00-04, 3
BPA1	Pilot Collective Grip RADIO SEL S2	7C827-00-04, 3
BPA2	Pilot Collective Grip RADIO SEL S2	7C827-00-04, 3
BPA3	Pilot Collective Grip RADIO SEL S2	7C827-00-04, 3
BPA4	Pilot Collective Grip RADIO SEL S2	7C827-00-04, 3
BPA5	Pilot Collective Grip RMT/ICS (ICS) S1	7C827-00-04, 3
BPA6	Pilot Collective Grip RMT/ICS (Radio) S1	7C827-00-04, 3
BPA7	Pilot Cyclic Grip WPN SEL S1 (Right)	7C827-00-02, 1
BPB0	Pilot Cyclic Grip HVR BOB UP S10	7C827-00-02, 2
BPB1	Pilot Cyclic Grip Configuration Check	7C827-00-02, 1
BPB2	Not Used	7C827-00-02, 1
BPB3	Pilot Cyclic Grip Trigger S11, 2nd Detent	7C827-00-02, 1
BPB4	Pilot Cyclic Grip Trigger S11, 1st Detent	7C827-00-02, 1
BPB5	Pilot Cyclic Grip WPN FIRE S8	7C827-00-02, 1
BPB6	Not Used	7C827-00-02, 1
BPB7	Pilot Cyclic Grip SCAS REL S7	7C827-00-02, 1
BPC0	Pilot Cyclic Grip MSL ACTIVE S6	7C827-00-02, 1
BPC1	Pilot Cyclic Grip TRIM REL S5	7C827-00-02, 1
BPC2	Pilot Cyclic Grip MSL STEP S4	7C827-00-02, 1
BPC3	Pilot Cyclic Grip OPT DISP S3	7C827-00-02, 1
BPC4	Pilot Cyclic Grip MMS FXD FWD S2	7C827-00-02, 1
BPC5	Pilot Cyclic Grip WPN SEL S1 (Down)	7C827-00-02, 1
BPC6	Pilot Cyclic Grip WPN SEL S1 (Up)	7C827-00-02, 1
BPC7	Pilot Cyclic Grip WPN SEL S1 (Left)	7C827-00-02, 1
DPB0	Copilot Cyclic Grip MNL/SLAVE S7	7C827-00-03, 2

**Table 3. OH-58D Configuration-Specific, Interface
System Assignments (Cont)**

<u>I/O Assigned</u>	<u>Description</u>	<u>System Print/Sheet</u>
DIs (Cont)		
DPB1	Copilot Cyclic Grip Configuration Check	7C827-00-03, 1
DPB2	Not Used	7C827-00-03, 1
DPB3	Copilot Cyclic Grip Trigger S11, 2nd Detent	7C827-00-03, 1
DPB4	Copilot Cyclic Grip Trigger S11, 1st Detent	7C827-00-03, 1
DPB5	Copilot Cyclic Grip Trigger DESIG S6	7C827-00-03, 1
DPB6	Not Used	7C827-00-03, 1
DPB7	Copilot Cyclic Grip Trigger SCAS REL S9	7C827-00-03, 1
DPC0	Copilot Cyclic Grip Trigger PNT TRK S10	7C827-00-03, 1
DPC1	Copilot Cyclic Grip Trigger TRIM REL S8	7C827-00-03, 1
DPC2	Copilot Cyclic Grip Trigger TV/TIS S5	7C827-00-03, 1
DPC3	Copilot Cyclic Grip Trigger FR FRZ S2	7C827-00-03, 1
DPC4	Copilot Cyclic Grip Trigger LASER S3	7C827-00-03, 1
DPC5	Copilot Cyclic Grip Trigger AREA TRK S2	7C827-00-03, 1
DPC6	Copilot Cyclic Grip Trigger FOV Select S1	7C827-00-03, 1
DPC7	Copilot Cyclic Grip Trigger FOV Select S1	7C827-00-03, 1
PC0	Copilot Cyclic Grip Trigger DISP SEL S9 (Up)	7C827-00-02, 1
PC1	Copilot Cyclic Grip Trigger DISP SEL S9 (Left)	7C827-00-02, 1
PC2	Copilot Cyclic Grip Trigger DISP SEL S9 (Down)	7C827-00-02, 1
PC3	Copilot Cyclic Grip Trigger DISP SEL S9 (Right)	7C827-00-02, 1
AIs		
CH0	Copilot Cyclic Grip LOS S12 (X-Axis)	7C827-00-03, 2
CH1	Copilot Cyclic Grip LOS S12 (Y-Axis)	7C827-00-03, 2

Table 4. AH-64 Configuration-Specific, Interface System Assignments

<u>I/O Assigned</u>	<u>Description</u>	<u>System Print/Sheet</u>
DIs		
APA4	ORT Left Grip Trigger S7	7C831-09-01, 1
APA5	ORT Left Grip LMC S6	7C831-09-01, 1
APA6	ORT Left Grip GUN RKT/MSL S3	7C831-09-01, 1
APA7	ORT Left Grip GUN RKT/MSL S3	7C831-09-01, 1
APB0	ORT Left Grip FLIR/TV/DVO S1	7C831-09-01, 1
APB1	ORT Left Grip FLIR/TV/DVO S1	7C831-09-01, 1
APB2	ORT Left Grip UPDT/ST S8	7C831-09-01, 1
APB3	ORT Left Grip UPDT/ST S8	7C831-09-01, 1
APB4	ORT Left Grip IAT/MAN S5	7C831-09-01, 1
APB5	ORT Left Grip IAT/OFS S4	7C831-09-01, 1
APB6	ORT Left Grip NMW/FOV S2	7C831-09-01, 1
APB7	ORT Left Grip NMW/FOV S2	7C831-09-01, 1
APC0	Pilot Collective Grip Configuration Check	7C827-00-04, 2
APC1	Pilot Collective Grip Configuration Check	7C827-00-04, 2
APC2	Pilot Collective Grip ST JETT S6	7C827-00-04, 2
APC3	Pilot Collective Grip ST JETT S6	7C827-00-04, 2
APC4	Pilot Collective Grip Director R S5	7C827-00-04, 2
APC5	Pilot Collective Grip Director RET S5	7C827-00-04, 2
APC6	Pilot Collective Grip Director L S5	7C827-00-04, 2
APC7	Pilot Collective Grip Director EXT S5	7C827-00-04, 2
BPA0	Pilot Collective Grip SRCH LT STOW S4	7C827-00-04, 2
BPA1	Pilot Collective Grip SRCH LT ON S4	7C827-00-04, 2
BPA2	Pilot Collective Grip RF ORIDE S3	7C827-00-04, 2
BPA3	Pilot Collective Grip Bore Sight S2	7C827-00-04, 2
BPA4	Pilot Collective Grip Bore Sight S2	7C827-00-04, 2
BPA5	Pilot Collective Grip NVG S1	7C827-00-04, 2
BPA6	Pilot Collective Grip NVG S1	7C827-00-04, 2
BPB1	Pilot Cyclic Grip Configuration Check	7C827-00-02, 4
BPB2	Pilot Cyclic Grip Configuration Check	7C827-00-02, 4
BPB3	Pilot Cyclic Grip XMIT SEL (Radio) S6	7C827-00-02, 4
BPB4	Pilot Cyclic Grip XMIT SEL (ICS) S6	7C827-00-02, 4
BPB5	Not Used	7C827-00-02, 4
BPB6	Pilot Cyclic Grip Trigger S5	7C827-00-02, 4
BPB7	Pilot Cyclic Grip SYM SEL (UP) S4	7C827-00-02, 4

**Table 4. AH-64 Configuration-Specific, Interface
System Assignments (Cont)**

<u>I/O Assigned</u>	<u>Description</u>	<u>System Print/Sheet</u>
DIs (Cont)		
BPC0	Pilot Cyclic Grip SYM SEL (Down) S4	7C827-00-02, 4
BPC1	Pilot Cyclic Grip WPN ACTN (Down) S3	7C827-00-02, 4
BPC2	Pilot Cyclic Grip WPN ACTN (Left) S3	7C827-00-02, 4
BPC3	Pilot Cyclic Grip WPN ACTN (Up) S3	7C827-00-02, 4
BPC4	Pilot Cyclic Grip WPN ACTN (Right) S3	7C827-00-02, 4
BPC5	Pilot Cyclic Grip FORCE TRIM REL (ON) S2	7C827-00-02, 4
BPC6	Pilot Cyclic Grip FORCE TRIM OFF S2	7C827-00-02, 4
BPC7	Pilot Cyclic Grip ASE S1	7C827-00-02, 4
CPA1	Left Console Panel Active Switch S2	7C823-04-03, 2
CPA2	Left Console Panel Active Switch S1	7C823-04-03, 2
CPA3	Right Console Panel Active Switch S2	7C823-04-03, 2
CPA7	ORT Right Grip Trigger S7	7C831-09-01, 2
CPB0	ORT Right Grip SLAVE S4	7C831-09-01, 2
CPB1	Not Used	7C831-09-01, 2
CPB2	ORT Right Grip IAT PLRT S6	7C831-09-01, 2
CPB3	ORT Right Grip IAT PLRT S6	7C831-09-01, 2
CPB4	ORT Right Grip FLIR PLRT S3	7C831-09-01, 2
CPB5	ORT Right Grip LT AUTO/OFF/MAN S5	7C831-09-01, 2
CPB6	ORT Right Grip LT AUTO/OFF/MAN S5	7C831-09-01, 2
CPB7	ORT Right Grip HDD S2	7C831-09-01, 2
CPC0	ORT Right Grip VID/RCD S1	7C831-09-01, 2
CPC1	Copilot Collective Grip Configuration Check	7C827-00-05, 2
CPC2	Copilot Collective Grip Configuration Check	7C827-00-05, 2
CPC3	Copilot Collective Grip ST JETT S6	7C827-00-05, 2
CPC4	Copilot Collective Grip ST JETT S6	7C827-00-05, 2
CPC5	Copilot Collective Grip Director R S5	7C827-00-05, 2
CPC6	Copilot Collective Grip Director RET S5	7C827-00-05, 2
CPC7	Copilot Collective Grip Director L S5	7C827-00-05, 2
DPA0	Copilot Collective Grip Director EXT	7C827-00-05, 2
DPA1	Copilot Collective Grip SRCH LT STOW S4	7C827-00-05, 2

**Table 4. AH-64 Configuration-Specific, Interface
System Assignments (Cont)**

<u>I/O Assigned</u>	<u>Description</u>	<u>System Print/Sheet</u>
DIs (Cont)		
DPA2	Copilot Collective Grip SRCH LT STOW S4	7C827-00-05, 2
DPA3	Copilot Collective Grip RF ORIDE S3	7C827-00-05, 2
DPA4	Copilot Collective Grip Bore Slight S2	7C827-00-05, 2
DPA5	Copilot Collective Grip Bore Sight S2	7C827-00-05, 2
DPA6	Copilot Collective Grip NVG S1	7C827-00-05, 2
DPA7	Copilot Collective Grip NVG S1	7C827-00-05, 2
DPB1	Copilot Cyclic Grip Configuration Check	7C827-00-03, 4
DPB2	Copilot Cyclic Grip Configuration Check	7C827-00-03, 4
DPB3	Copilot Cyclic Grip XMIT SEL (Radio) S6	7C827-00-03, 4
DPB4	Copilot Cyclic Grip XMIT SEL (ICS) S6	7C827-00-03, 4
DPB5	Not Used	7C827-00-03, 4
DPB6	Copilot Cyclic Grip Trigger S5	7C827-00-03, 4
DPB7	Copilot Cyclic Grip SYM SEL (UP) S4	7C827-00-03, 4
DPC0	Copilot Cyclic Grip SYM SEL (Down) S3	7C827-00-03, 4
DPC1	Copilot Cyclic Grip WPN ACTN (Down) S3	7C827-00-03, 4
DPC2	Copilot Cyclic Grip WPN ACTN (Left) S3	7C827-00-03, 4
DPC3	Copilot Cyclic Grip WPN ACTN (Up) S3	7C827-00-03, 4
DPC4	Copilot Cyclic Grip WPM ACTN (Right) S3	7C827-00-03, 4
DPC5	Copilot Cyclic Grip FORCE TRIM REL ON S2	7C827-00-03, 4
DPC6	Copilot Cyclic Grip FORCE TRIM OFF S2	7C827-00-03, 4
DPC7	Copilot Cyclic Grip ASE S1	7C827-00-03, 4

Table 4. AH-64 Configuration-Specific, Interface System Assignments (Cont)

<u>I/O Assigned</u>	<u>Description</u>	<u>System Print/Sheet</u>
DIs (Cont)		
PC0	Copilots ICS Footswitch (Right) S11	7C823-04-04, 2
PC1	Copilots Radio Footswitch (Left) S10	7C823-04-04, 2
PC2	Pilots ICS/Radio Footswitch (Right) S13	7C823-04-04, 2
DOs		
PA3	Right Console Panel Back Light DS1/DS2	7C823-04-02, 1
PB1	Left Console Panel Back Light DS1/DS 2	7C823-04-02, 1
PB1	Left Console Panel Back Light DS3/DS4	7C823-04-02, 2
AIs		
CH4	ORT Right Grip MAN/TRK S8 (X-Axis)	7C831-09-01, 3
CH5	ORT Right Grip MAN/TRK S8 (Y-Axis)	7C831-09-01, 3

2.2.2.1 DIO-96 Card

The DIO-96 is a 96-bit (I/O channel), parallel, digital I/O interface card for a PC. All digital I/O is through a standard, 100-pin, male ribbon header connector. The digital I/O card uses four 24-bit programmable peripheral interfaces (PPIs). Each PPI is further divided into three 8-bit ports which explains the connector pin assignments. One PPI transfers digital data from signals received at APA0-APA7, APB0-APB7, and APC0-APC7 ports (24-bit PPI separated into three 8-bit ports). Another PPI transfers digital data from signals received at -BPA7, BPB0-BPB7, and BPC0-BPC7 ports. The remaining two PPIs transfer in the same manner but use data received/designated CPxx and DPxx, where the first x = A-C and the second x = 0-7. Each bit represents a single I/O input point.

The card uses TTL logic, i.e., 0.0 - 0.8 Vdc for an input logic low and 2.0 - 5.25 Vdc for an input logic high. DI true conditions are sensed when a DI RTN (GNDI) is passed through the active switch contacts and pulled-up to 5 Vdc prior to being input to the DIO-96 card. After transferred, input logic highs are represented as a 1 and logic lows as a 0. DI inputs are routed to the 100-pin connector via two I/O connector blocks. For a pictorial of connector pin assignments, refer to PC-DIO-96 User Manual. Key functional components of the DIO-96 card include the following:

PC I/O Channel. Consists of an address bus, a data bus, interrupt lines, and several control and support signals.

Data Transceivers. Control the sending and receiving of data to and from the PC I/O channel. Buffers the data lines to and from the PC bus. All data transfers are 8-bit.

PC I/O Channel Control Circuitry. Consists of address latches, address decoding circuitry, data buffers, and interface timing control signals. The I/O base address is controlled by dip switch U26 and currently set to hex 180 (uses 180 through 19F). The address on the PC I/O channel is monitored by the address decoder. If the address on the bus matches the selected I/O base address of the board, the board is enabled and the corresponding register is accessed. The channel control circuitry also monitors and transmits the PC I/O channel control and support signals. The control signals identify transfers as read or write, memory or I/O, and 8-bit, 16-bit, or 32-bit transfers. Only 8-bit transfers are used.

OKI 82C55A Programmable Peripheral Interface (PPI). Four PPI chips are provided on the card. Each of these chips has 24 programmable I/O pins that represent three 8-bit ports: PA, PB, and PC. In this configuration, each is programmed as an input port since the board is dedicated for DI use. The PPIs are capable of operating in three modes: Mode 0, Mode 1, and Mode 2. Reflectone-developed software only requires Mode 0 (simple I/O) operation. For mode descriptions, refer to PC-DIO-96 User Manual.

8253 Programmable Interval Timer. Provided to generate timed interrupt requests to the Host PC. Not used in this configuration.

Interrupt Control Circuitry. The interrupt level is set by W 1 and currently configured for IRQ5. This is irrelevant, however, since no device interrupts are used in this configuration.

2.2.2.2 DIO-24 Card

The DIO-24 is a 24-bit (I/O channel), parallel, digital I/O interface card for a PC. All digital I/O is through a standard, 50-pin, male ribbon header connector, with all even pins attached to logic ground. The digital I/O card uses a single 24-bit programmable peripheral interface (PPI). The PPI is divided into three 8-bit ports which explains the connector pin assignments. The PPI transfers digital data from signals received at PA0-PA7, PB0-PB7, and PC0-PC7 ports (24-bit PPI separated into three 8-bit ports). Each bit represents a single I/O input or output point.

Because of the amount of DIs required in the test bed, this card has been configured to transfer both digital inputs and digital outputs. The first 16 bits (PA and PB) are programmed for digital outputs and the remaining 8-bits (PC) for digital inputs. Each type of signal is routed to/from the card on the bi-directional ribbon cable. For a pictorial of connector pin assignments, refer to PC-DIO-24 User Manual.

The card uses TTL logic, i.e., 0.0 - 0.8 Vdc for an input logic low, 2.0 - 5.25 Vdc for an input logic high, 0.0 - 0.4 Vdc for an output logic low, and 3.7 - 5.0 Vdc for an output logic high. DI true conditions are sensed when a DI RTN (GND) is passed through the active switch contacts and pulled-up to 5 Vdc prior to being input to the DIO-24 card. After transferred, input logic highs (true DIs) are represented as a 1 and logic lows as a 0. DO true conditions are output to the ER- 16 relay module in the form of ground when dictated by the Host PC. This ground is used to energize the associated SPDT relay in the ER- 16 relay module assembly, ultimately performing a specific function like illuminating a light/indicator, activating a relay, etc. True DO conditions are represented digitally as a 1 and inactive DOs as a 0. Key functional components of the DIO-- 24 card include the following:

PC I/O Channel. Consists of an address bus, a data bus, interrupt lines, and several control and support signals. Control and data transfers to the Host PC are asynchronous.

Address Decoder. The base address is controlled by dip switch U2 and currently set to hex 210 (uses 210 through 213). The address on the PC I/O channel is monitored by the address decoder. If the address on the bus matches the selected I/O base address of the board, the board is enabled and the corresponding register is accessed.

Bus Transceivers. Control the sending and receiving of data to and from the PC I/O channel. Buffers the data lines to and from the PC bus. All data transfers are 8-bit.

PC I/O Channel Control Circuitry. The channel control circuitry monitors and transmits the PC I/O channel control and support signals. The control signals identify transfers as read or write, configuration or I/O, and 8-bit or 16-bit transfers. Only 8-bit transfers are used.

QKI 82C55A Programmable Peripheral Interface (PPI). A single PPI chip is provided on the card and has 24 programmable I/O pins that represent three 8-bit ports: PA, PB, and PC. In this configuration, the first 16 bits (PA and PB) are programmed as output ports and the remaining 8-bits (PC) as an input port. The PPI is capable of operating in three modes: Mode 0, Mode 1, and Mode 2. Reflectone-developed software only requires Mode 0 (simple I/O) operation. For mode descriptions, refer to PC-DIO-24 User Manual.

Interrupt Control Circuitry. The interrupt level is controlled by W2 and enabled by W1. Currently configured for IRQ5 with PC4 as the active enable line. This is irrelevant, however, since no device interrupts are used in this configuration.

2.2.2.3 ADIO1600 Card

The ADIO1600 is a multifunction high-speed I/O card for use in an IBM-compatible PCs. Its circuitry is capable of analog input, analog output, digital input, and digital output interfacing. Currently, only the analog input circuitry is utilized. The card also houses circuits for a counter/timer, programmable interval timer, and interrupt processing. These features are also not used in this configuration.

The card accepts up to eight differential or 16 single-ended analog input channels. Only single-ended analog inputs are used in this configuration. Inputs are protected against over voltages by internal multiplexer diodes connected to + and - positions of the power supply. Inputs are amplified by an instrumentation amplifier with a combination of switch selectable gains of 1 or 2, and software selectable gains of 1000, 100, 10, and 1. This provides voltage ranges of 0.005, 0.01, 0.05, 0.1, 5, and 10 Volts bipolar and 0.01, 0.1, 1, and 10 Volts unipolar (gain switch must be set to x2). In this configuration, bipolar operation is used to provide a ± 5 Volt range. Gain is set for 1.

2.2.2.4 ER- 16 Relay Module

The ER- 16 relay module contains 16 SPDT relays that are controlled by 16 DOs (from DIO-24 card), and a 26-pin OUT connector (J3) for routing DIs directly to the 50-pin ribbon connector/cable. Each relay has a normally closed (NC) contact that connects to the common (COM) contact when the corresponding digital output line is low, and a normally open (NO) contact that connects to the COM contact when the line is high. The contacts are break-before-make so that all three contacts can never short together. Output discrete wiring is connected to internal NC screw terminals and then routed to the end user equipment. COM connections at the screw terminals are electrically connected to various dc power or dc RTN points. An external +5

Vdc power supply connection (J8) is used to power the relay coils/assembly. Since this is the case, the EXT/INT switch is placed to the EXT position.

All discrete DIs are received at J3 via the applicable I/O distribution panel pull-up resistor network and sent directly to the DIO-24 card. Digital input channels do not utilize the ER-16 module relay assemblies. For a pictorial of connector pin assignments, refer to ER-8/16 User Manual.

2.2.2.5 Connector Blocks

Two National Instrument connector blocks are used in this configuration for digital I/O and are mounted on the I/O distribution panel. Each CB-50LP connector block acts as a termination board with 50 screw terminals for easy connection with discrete wiring. The two single 50-pin ribbon header connectors provide direct connection to the DIO-96 card (combined to a 100 pin female connector). The top connector block is designated A1 and the bottom A2. Two rows of 25 screw terminals are provided: left designated TB 1 for even numbered connections and the right designated TB2 for odd numbered connections. All cockpit discrete (DI) and pull-up resistor network wiring is routed directly to the applicable terminal board and transferred via copper paths to the header connector. Each terminal connection used has two wires attached: one from the cockpit component and one from the associated pull-up resistor.

2.2.2.6 Distribution Block

A 2M37DSM I/O connector block (A33) is provided for connecting cockpit-side discrete analog wiring with the ADIO1600 card. A distribution box output is a "Y" cable and is attached to the I/O connector of the card.

2.2.2.7 I/O Distribution Panel

The I/O distribution panel provides connection points for both I/O and power related signals. It houses two I/O connector blocks and numerous jack and terminal board connections. Jacks are used in a logical manner, i.e., a single Jack is used for both configurations of cyclic's, etc. Jacks/plugs are assigned to specific equipment as follows:

J1	Not Used
J2	Not Used
J3	Not Used
J4	Pilot Cyclic (OH-58D and UH-60)
J5	Left Console (AH-64)
J6	Pilot Collective (OH-58D, UH-60, and AH-64)
J7	Center Console (UH-60 and AH-64)
J8	Left ORT Grip (AH-64)
J9	Copilot Cyclic (OH-58D and UH-60)

J10	Right Console (AH-64)
J11	Copilot Collective (OH-58D, UH-60, and AH-641)
J12	Right ORT Grip (AH-64)
J13	Not Used
J14	Pilot OTW Display

Pull-up resistor networks are provided on terminal boards TB1-TB6 and TB-8. All DIs are electrically connected to these networks either directly at the network or at the I/O connector box. All DIs being routed to the DIO-96 board are connected to the resistor networks at the I/O connector box. DIs being routed to the DIO-24 card, are connected directly to the resistor network and then routed to the ER-16 relay module. These resistors provide the means to place 5 Vdc on the input line when a true DI condition is felt (DI RTN). The remaining terminal board (TB7) is used primarily for DI RTNS, dc power, and source voltage.

2.3 Visual System

The visual system utilizes both off-the-shelf vendor equipment, as well as, prototype equipment to reproduce the visual imagery necessary to support both Pilot and Copilot training. For description purposes, the following equipment is considered part of the visual system.

- Host PC/Image Generator
- Barco 29" Color Displays (2)
- Pilot Helmet Mounted Display (HMD)
- HMD CRT Electronics Unit
- HMD Color Wheel Electronics Unit
- Head Tracker

The following paragraphs provide a brief functional description for each of the related equipment.

2.3.1 Host PC/Image Generator

Communications between the Host PC and the image generator are required so that a realistic real-time image can be displayed on an appropriate display. The Host PC (IG interface module) provides data to the image generator (via Ethernet,) so that it can process/calculate world and eyepoint positions. Data transferred includes ownship position and orientation, raw head tracker data, Pilot Multi-Function Display (MFD) or Visual Display Unit (VDU) offsets, magnification, and color mode (FLIR, B+W), Copilot MFD or Optical Relay Tube (ORT) offsets, magnification and color mode, Line-of-Sight (LOS) requests, etc. The image generator provides the Host PC with height above terrain (HAT) information, etc.

A SGI Onyx Infinite Reality Graphics Workstation is provided with the test bed for generating the visual out-the-window (OTW), Helmet Mounted Display (HMD), sensor, and night-vision-goggle (NVG) images as they apply for the modeled Hunter-Liggett database. In addition, the image generator can also provide for infrared imagery (IR), heads-up-display (HUD), OH-58D Pilot Display Unit (PDU) and symbology overlay effects. This self-contained visual system provides a high performance computer graphics platform.

A total of five image generation (IG) channels are available to provide for all simultaneous OTW and sensor images. The ARMS-TB automatically configures itself for optimum use of the five channels based on current active system operations. A typical scenario includes two active OTW channels for the Pilot HMD, one OTW channel for the copilot forward OTW display, and up to two sensor channels for AH-64 Video Display Unit (VDU), AH-64 Optical Relay Tube (ORT), or OH-58D Multi-Function Display (MFD) use. In the event the selected training situation requires more than five channels of imagery, a logical re-assignment occurs while the requirement exists. Selections made during visual system initialization provide the image generator with the proper operating mode (Modes 1-6). Refer to Table 5 for image generator channel assignments.

The IG includes all hardware and software necessary for generating the high resolution, imagery derived, perspective scene. This capability includes 120° horizontal field-of-view (FOV) and 60° vertical FOV, any altitude, and any airspeed fly-through. It has capability to generate day, dusk, and night imagery, and can change from day to dusk to night simulation during a mission without system re-initialization. This is selectable from the control displays available at the cock-pit management display.

Images appear optically correct for each crew position. Visibility obscuration effects are included in the visual and sensor scenes. Capability to generate imagery with surface translucency and shading, nongeospecific texturing, shadowing, and various lighting effects are provided. All fixed models, moving models, articulated parts, special effects, threats and weapon effects generated are fully integrated with the database in terms of texture, color, light control, etc. The database is dynamically updated as the viewpoint moves through the database. For detailed descriptions on the image generator, refer to applicable vendor documentation.

2.3.2 29" Color Displays

There are two 29" high resolution color Barco CRT displays (monitors): one is provided for Pilot and the other for the Copilot out-the-window (OTW) displays. Video is provided to the monitor(s) via the image generator and displayed at a resolution of 1280 by 1024. Both OTW monitors use a RGB (sync on green) cable connection on the rear panel, and are switched for internal sync. RGB video supplied to the Pilot's monitor is also output at the rear panel and fed to the HMD CRT Electronics Unit. RGB video supplied to the Copilot's monitor is also output at the rear panel and fed to the development monitor on the data table for use as a remote

repeater. Since monitor outputs are used, both displays are not terminated (by switches) and differ from the 29" instrument monitors.

Circuits are provided in the system to direct the Pilot's visual image to either the HMD or OTW display. Configuration selections made during visual system initialization cause the Host PC to initiate the appropriate data to enable/disable power to one or the other. This occurs when the applicable I/O system discrete outputs (DOs) are received by relay assemblies located in both the I/O distribution panel and I/O relay unit (ER- 16).

Table 5. ARMS-TC Image Generator Channels

	OH-58D		UH-60		AH-64	
	MODE #1 (HMD)	MODE #2 (OTW)	MODE #3 (HMD)	MODE #4 (OTW)	MODE #5 (HMD)	MODE #6 (OTW)
Chan 0	HMD - Left	Pilot-OTW	HMD-Left	Pilot-OTW	HMD-Left	Pilot-OTW
Chan 1	HMD-Right	N/U	HMD-Right	N/U	HMD-Right	N/U
Chan 2	CPLT-OTW	CPLT-OTW	CPLT-OTW	CPLT-OTW	CPLT-OTW	CPLT-OTW
Chan 3	Pilot MFD	Pilot MFD	N/U	N/U	Pilot VDU	Pilot VDU
Chan 4	CPLT MFD	CPLT MFD	N/U	N/U	ORT CRT	ORT CRT

HMD-Left: Left eye of HMD. Ownship position + nominal eye offset + dynamic head tracked position offset.

HMD-Right: Right eye of HMD. Ownship position + nominal eye offset + dynamic head tracked position offset.

CPLT-OTW: Copilot out-the-window. Ownship position + offset to window perspective.

Pilot-OTW: Copilot out-the-window. Ownship position + offset to window perspective.

Pilot MFD: Pilot sensor image. Ownship position + dynamic offset to sensor perspective.

CPLT MFD: Copilot sensor image. Ownship position + dynamic offset to sensor perspective.

Pilot VDU: Pilot sensor image. Ownship position + dynamic offset to sensor perspective.

ORT CRT: Copilot sensor image. Ownship position + dynamic offset to sensor perspective.

N/U: Not used.

2.3.3 Helmet Mounted Display (HMD)

The Helmet Mounted Display (HMD) (Figure 3.) is provided with the test bed as the Pilot's primary visual display. It is currently Reflectone's original prototype helmet, so certain limitations, adjustment problems, electronic shortfalls, etc., were addressed and corrected on the production unit available in the near future. In addition, materials and packaging techniques have also been improved.

The prototype helmet provides a 70° horizontal by 50° vertical active raster, limited by the 70° circular field-of-view. Both optical systems are aligned with each other to provide a 40° overlap area. The helmet houses a full contact interchangeable thermoplastic liner, weighs less than 5.5 lb., fits up to the 95th percentile, provides interpupillary distance (IPD) adjustment, and provides eye relief adjustment. Display characteristics (estimated) include a resolution of 700 pixels by 525 lines (limited by IG), with a >30% see-through and >12 FL luminance.

The helmet assembly houses the onboard components necessary to display the appropriate color out-the-window (OTW), night vision goggle (NVG), or sensor image. Each image type is a result of video generated by the image generator for the configuration selected. The major helmet mounted internal and external components include:

- Dual CRTs
- Dual Color Wheel Assemblies (Motor, Wheel Housing, and Colored Filters)
- Dual Lens Assembly (10 Lens - Located Inside Relay Tubes)
- Dual Mirrors (Located Inside Mirror Mount)
- Dual Ocular Assemblies (Beamsplitter and Spherical Substrate)
- Dual Electronic Components (CRT Interface Card, Video Amp, etc.,)
- Dual Fit Adjustment Controls (IPD and Eye Relief)
- Head Tracker Receiver

The following paragraphs describe basic operation for a single channel, since both channels (left and right) are identical.

Various video, drive (vertical processing, horizontal drive, G1, G2, filament, cathode, and focus) and power (anode) related signals generated by the HMD CRT electronics unit are routed via a special 17-pin D-style connector (two pins RG-174) and high voltage modified BNC to the input section of the helmet (pod assembly). The CRT electronics unit develops these signals as a result of the HS, VS, RGB video received from the image generator and internal power circuits.

Most signals (G1, G2, filament, cathode video, and ground) are routed directly to the onboard CRT Interface assembly/card. The interface card contains a high speed hybrid video amplifier, and passive components required to protect both the CRT and drive electronics from voltages applied to the CRT. Board components form a G1 network, G2 network, high speed decoupling

network, impedance matching network, and filament bypass circuit. All signals are passed to the CRT via the CRT base pins

Focus, anode, vertical drive, and horizontal drive signals from the CRT electronics unit are applied directly to the CRT. The vertical and horizontal drive signals are applied to the yoke deflection coil, focus power to the base pins, and anode power to anode element connection..

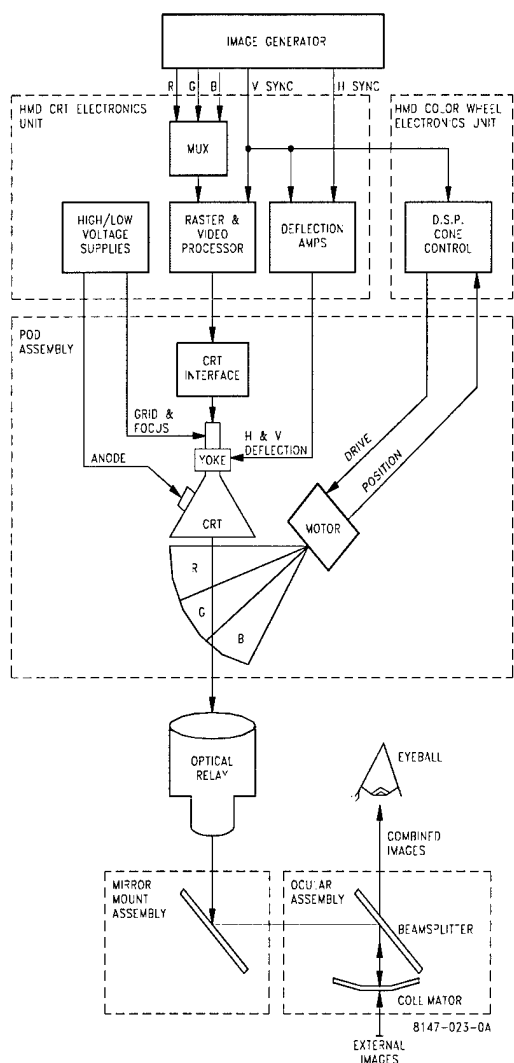

Figure 3. Helmet Mounted Display System, Block Diagram

These signals cause the 1.5-inch, white phosphor, high resolution CRT to produce the resultant black and white image. To produce the image in color, color wheel (cone) technology and field sequential color (FSC) video encoding are used. A HMD color wheel electronics unit, color wheel motor, and color wheel with attached filters provide this color modulation function. Two sets of red, green, and blue filters (six total) are physically glued to the cone. The HMD color wheel electronics unit uses input vertical sync and video information to synchronize the color wheel motor, ensuring that the motor is advanced or retarded in a manner to keep the appropriate filter color in front of the leading portion of the video raster. This method of separately modulating the red, green, and blue (RGB) frames sequentially, causes the human eye/brain to sense the image as a continuous color frame.

The colonized image light qualities are picked up by the optical lens assembly (also referred to as optical relay) located in the helmet's relay tube. The optical relay and mirror assembly directs the CRT (phosphor) image to the focal plane of the ocular. The optical relay incorporates ten custom-grounded elements (lenses) that are spaced at precise distances and attitudes.

The ocular assembly consists of a flat beamsplitter and spherical substrate (collimator), and is mounted via the mechanical ocular bridge assembly. Trichromatic light emerging from the optical relay strikes the mirror, directing the image to the beamsplitter. The light is partially (50%) reflected to the collimator and then reflected back through the beamsplitter to the exit pupil of the system, which is located at the Pilot's eye position. More than 15 FL luminosity is provided at the exit pupil to the observer's eye. The collimator allows external light (except for three bands that would compete with CRT wavelengths) to pass, providing a means to view outside world images.

The receiver mounted on top of the helmet is part of the Flock of Birds head tracking system. The Flock of Birds system is a measuring device that is configured to simultaneously track the position and orientation of the Pilot's head. As the Pilot's head turns, data is gathered relating to current position and routed to the Host PC via a RS-232 cable. The PC then sends the raw data on to the image generator so that it can update/alter the image.

Circuits are provided in the system to direct the Pilot's visual image to either the HMD or OTW display. Configuration selections made during visual system initialization cause the Host PC to initiate the appropriate data to enable/disable power to one or the other. This occurs when the applicable I/O system discrete outputs (DOs) are received by relay assemblies located in both the I/O distribution panel and I/O relay unit (ER- 16).

2.3.4 HMD CRT Electronics Unit

The HMD CRT electronics unit houses the circuit cards/components necessary to accept two channels of HS, VS, and RGB video from the image generator and produce the signals necessary to drive both HMD channels (CRTs). The unit is located in the electronics cabinet and contains video input circuitry, deflection processing circuitry, deflection amplifiers, and low and high

voltage power supplies. Dual video processing, deflection, and input switching circuitry is provided to separate the CRT drive channels. Both channels share single anode and focus (dual outputs) power supplies.

The CRT electronics unit provides numerous jacks/cable connectors on the front panel. The following jacks/connectors are used in this configuration: three RGB video input connectors per channel (two channels), one horizontal sync input connector per channel, one vertical sync input connector per channel, two 9-pin D-style connectors for color input select (to color wheel electronics), two special 17-pin D-style connectors for routing video signals (intensity, blanking, etc.) to HMD components, and two modified BNCs for routing high voltage to HMD CRTS. An equipment protection/safety interlock circuit is provided to ensure that high voltage is removed from the applicable modified BNC if the associated 17-pin D-style video cable is not connected.

Numerous controls and indicators are provided both internally and on the front panel. Internal controls are provided for adjusting geometric correction (keystone, pincushion, curvature, rotation, non-linearity, position, and size), calibration, anode voltage, CRT bias level, blanking, gain, position, and frequency trims. All controls are either factory set or only to be adjusted by qualified service engineers. External panel controls are provided for frequency select, focus, contrast, brightness, sweep reversal, and power related (main and beam) items. With the exception of frequency select and sweep reversal, all remaining external controls are customer adjustable. For panel indicator descriptions, refer to Chapter 2. Filtered ac power is supplied to the unit via the ac terminal board and the Gould two-phase ac filter box (both in electronics cabinet).

The following paragraphs provide brief descriptions for the major components of the HMD CRT electronics unit.

2.3.4.1 Low Voltage Power Supply

This PCB assembly provides all operating dc voltages required except for the HMD CRT anode voltage. One assembly provides power for both channels. The following individual voltages are produced:

- 12 Vdc Regulated
- -12 Vdc Regulated
- 32 Vdc Regulated
- 32 Vdc Regulated
- +24 Vdc Regulated
- +55 Vdc Regulated
- -55 Vdc Regulated
- 600 Vdc Regulated (Focus Supply)
- 300 Vdc Regulated (CRT G2 Supply)
- -75 Vdc Unregulated
- +28 Vdc Unregulated

- -28 Vdc Unregulated

All of the regulated supplies use monolithic three terminal voltage regulators that are short circuit proof, thermal overload protected, and are resistant to arcing. A single soldered-in fuse is located on the PCB for the 600V and 300V supply. This protects the transformer from shorts or failure on the supply.

2.3.4.2 CRT Bias Assembly

Two CRT bias assemblies are provided: one for each channel. The bias circuit controls the associated CRT GI voltage. Normal GI voltage is between -55 Vdc and +0.6 Vdc. The circuit incorporates a phosphor-protect shut off control, bias adjustment, and power down phosphor protection.

2.3.4.3 Rapid Retrace Assembly

Two rapid retrace assemblies are provided: one for each channel. The rapid retrace feature provides an accelerated pulse to the horizontal deflection yoke coil to facilitate a high speed retrace. Horizontal sweep rates tax the deflection linear amplifiers, limiting the ability to effectively execute reliable retrace. The rapid retrace pulse ensures that the retrace maintains ample recovery time. Each rapid retrace assembly operates as an electronic switch that is placed in series with the horizontal deflection amplifier output.

2.3.4.4 Raster MCB

Two raster master circuit board (MCB) assemblies are provided: one for each channel. Each assembly contains the active sweep generator circuitry required for the HMD electronics. Separated H and V syncs are used to trigger the onboard sweep and blank circuitry. The boards also house circuits for VCO control, H and V sweep generation, geometric correction, horizontal and vertical summing/buffering, and phosphor protection.

2.3.4.5 Dual Focus Power Supply

The dual focus power supply provides independent high voltage (1400 to 1900 Vdc, 100 μ a) focus outputs to each CRT focus electrode. It consists of a dc-dc converter that is operated in a precision mode via the feedback loop of an operational amplifier. External front panel control pots set the operating voltage.

2.3.4.6 Horizontal and Vertical Deflection Amplifiers

The deflection amplifiers for the horizontal (H) and vertical (V) axis' are quite similar. The H amplifier is optimized for high frequency operation and the V amplifier for low frequency. Both

consist of an operational amplifier input stage, a level shifter, and a complementary symmetry output stage. They are configured as current drive amplifiers.

2.3.4.7 Video Processor Assembly

The video processor PCB contains a color select decoder, a high speed analog switch, a high performance video processor integrated circuit, and an output buffer line driving amplifier. RGB signals are applied to the input and then the selected video is processed for gain, dc restore, brightness, and contrast.

2.3.4.8 High Voltage Power Supply

The high voltage power supply (HVPS) and transformer assembly provides the high voltage (up to 8000 Vdc) necessary for each CRT anode. Power is applied to the CRTs when the applicable BEAM power switch is placed to ON (with PWR ON switch in ON position).

2.3.5 HMD Color Wheel Electronics Unit

The HMD color wheel electronics unit is located in the electronics cabinet and houses a Reflectone-designed prototype synchronizer card and two miniature vendor-supplied dc motor electronic commutator cards. The purpose of the synchronizer card is to synchronize both HMD rotating color wheels to the applied video signals, thereby converting the black and white image into a color image. It contains a digital signal processor (DSP), programmable logic device (PLD), and numerous other electronic circuits. The DSP implements control algorithms to synchronize color wheel position with the vertical sync input. The PLD simply processes the digital inputs (logic). Each commutator card drives the associated left or right pod color wheel motor and processes returned hall effects (feedback) for continuous and accurate motor positioning. A single hall effect (S1) is monitored by the color wheel electronics unit for position information.

Power requirements are met through + 15 and ± 5 Vdc power connections with the electronics cabinet power supply rack. The power is routed to the electronics unit via the dc distribution panel. Other electrical connections include the vertical sync inputs for both channels (coax tee's off of HMD CRT electronics unit faceplate) and input/output motor connections to both HMD channels (to/from dc motor commutator cards).

Three toggle switches protrude through the color wheel electronics unit case. The top switch is for RESET, middle for LEFT PHASE ADJUST, and bottom for RIGHT PHASE ADJUST. These switches were provided for prototype development only and should not be touched.

2.3.6 Head Tracker

The Flock of Birds (FOB) head tracker system is a six degree-of-freedom measuring device that is configured to simultaneously track the position and orientation of the Pilot's head. The system consists of an external transmitter, receiver, and electronics unit. The transmitter is mounted via tie-wraps on non-conductive/non-metallic material (wood frame) and is positioned above the Pilot's seat/head. This ensures that the receiver and transmitter stay within a required three-foot operational boundary (range). The receiver is permanently mounted via two screws on top of the helmet. The electronics unit is located in the electronics cabinet.

The receiver circuits are capable of making up to 144 measurements per second. In this configuration, approximately 100 measurements are made per second. Position and orientation is determined when the receiver senses the transmitted pulsed dc magnetic field. From the measured magnetic field characteristics, the receiver/electronic unit computes its position and orientation and routes the resultant information to the Host PC. The Host PC passes the raw head tracker data on to the image generator at approximately 60 Hz, where the information is processed (prediction algorithm) and resultant line-of-sight vectors generated to change the HMD eyepoints (image) accordingly.

The head tracker electronic unit contains four electrical ports/connections that are used: an ac power plug that is connected to a cabinet ac power strip, a RS232C port/cable that is connected to the Host PC, and two connection ports for the external transmitter (.9-pin, labeled XMTR) and receiver (15-pin, labeled RECEIVER.) cables. Two 8-pin FBB modular connectors are provided for RS485 interface but not used in this configuration. In addition, a CRT SYNC jack is provided to help reduce CRT magnetic noise should it ever interfere with the receiver. At the present time, however, the SYNC circuit is not used.

2.4 Aural Cue/Seat Shaker System

The following paragraphs describe the Reflectone aural cue and seat shaker systems. These systems share equipment components and are described as one major system.

2.4.1 Vendor Equipment Description

The Reflectone digital aural cue/vibration systems utilize off-the-shelf vendor equipment to produce the sound and movement required to simulate each configurable environment. Table 6 defines the pertinent information relating to the vendor-supplied hardware equipment. It should be noted that there are additional components (not listed) that are part of the purchased computer system. This includes an Ethernet Adapter Card, VGA Video Adapter Card, Hard Disk Drive, and 3.5" 1.44 MB Floppy Disk Drive.

Table 6. Vendor-Supplied Hardware

Part Number	Qty	Vendor	Description
1132-240211-002	1	Service Integrators	386 DX-33, PC-Bus Industrial Computer
ASR-10R	1	Ensoniq	Digital Audio Sampler, Rack Mount
841664	2	Comp USA	4 Mbyte SIMM, 70ns Generic
R270D	1	Ramtek	SCSI Disk Drive Unit, Dual 270 MB Removeable (Single Drive Inserted)
RM270	1	Ramtek	3.5 Disk Cartridge, 270 Mbyte
25-50 3FT	1	Ramtek	SCSI System Cable 3 Ft.
Subsat 6 II	1	Boston Acoustics	Subwoofer (Satellite Speakers Not Provided)
KX6	2	DCM	Satellite Speakers
Model 1100	2	QSC	Audio Amplifier
Model 1500a	2	QSC	Audio Amplifier
MQX-32M	1	Music Quest	Dual Port MIDI Interface Card
MF-10 Black	2	Rapco Int.	MIDI Cable 10 ft Straight Conn
S-10 Black	8	Rapco Int.	Audio Cable 10 ft .25" Phone Plug
AV-60M	1	Alpha-M Manufacturing	Pilot Vibrator Assembly
M-60	1	Alpha-M Manufacturing	Copilot Vibrator Assembly
SLM-1A	2	Barry Controls	Stabl-Levl Vibration Mount
SLM-3A	2	Barry Controls	Stabl-Levl Vibration Mount

2.4.2 Aural Cue System Description

Sounds are generated for the selected test bed configuration and usable cues provided to the crew, simulating a small portion of the potential cues available for future mission training (Figure 4). Sound effects are currently provided for rotor and engine sounds, enemy weapons hit and near miss sounds, and ownship weapons impact sounds.

The system uses full 16-bit advanced digital sampling technology for compact disc sound quality. All sounds are stored on SCSI hard disk cartridge and are downloaded into digital audio sampler memory for real-time playback under control of the system's IBM-compatible computer (aural cue IPC). The sampler produces outputs for a six-channel sound system consisting of a satellite and subwoofer speaker combination. The speaker system and crew headset audio is driven by two stereo audio power amplifiers. Delivered software includes CueSonic, a comprehensive sound simulation and sample development program which runs in the aural cue

system IPC. CueSonic's convenient menu-driven sample editing software, which is fully integrated with the system's real-time audio playback software, allows fast and accurate conversion of newly recorded sound segments into working samples ready for playback. Host computer interface software consisting of a host parameter conversion program and an Ethernet interface driver is also included.

The system employs the Musical Instrument Digital Interface (MIDI) to control the audio samplers from the aural cue PC. The MIDI interface, which was originally designed as a communications link between electronic musical instruments, is also well suited for aural simulation tasks since it contains all the commands necessary for sound effects activation and manipulation in real-time. These commands, which include note on and off (used for enabling and disabling playback of samples), pitch bending, and channel pressure (used for amplitude changes), allow any type of aural cue to be generated. Transient and steady-state aural cues are programmed quickly and are reproduced with relatively short samples. Communications between the aural cue computer and the host take place over an Ethernet interface at a iteration rate high enough to ensure that all dynamic aural cues are perceived to vary smoothly to test bed occupants.

2.4.2.1 Host Computer/Ethernet System

The host computer communicates with the aural cue computer (also referred to as aural cue IPC) via an Ethernet connection. Host PC software consists of a parameter conversion module, an initialization module, and an Ethernet I/O driver. The purpose of host parameter conversion module is to convert all host parameters required by the aural cue system into the format required by the aural cue IPC and to assemble all required parameters into a single contiguous parameter block for transfer to the aural cue IPC. The Ethernet I/O transfer routine is responsible for transferring the aural cue parameter block to the aural cue fPC at a fixed iteration rate of 30 Hz. A single software module performs initialization of system constants. When required by the test bed scenario, the host sends this data to the aural cue computer so it can initiate/change system sounds. CueSonic software (in aural cue computer) sits idle until real-time parameter transfers are received from the Host PC.

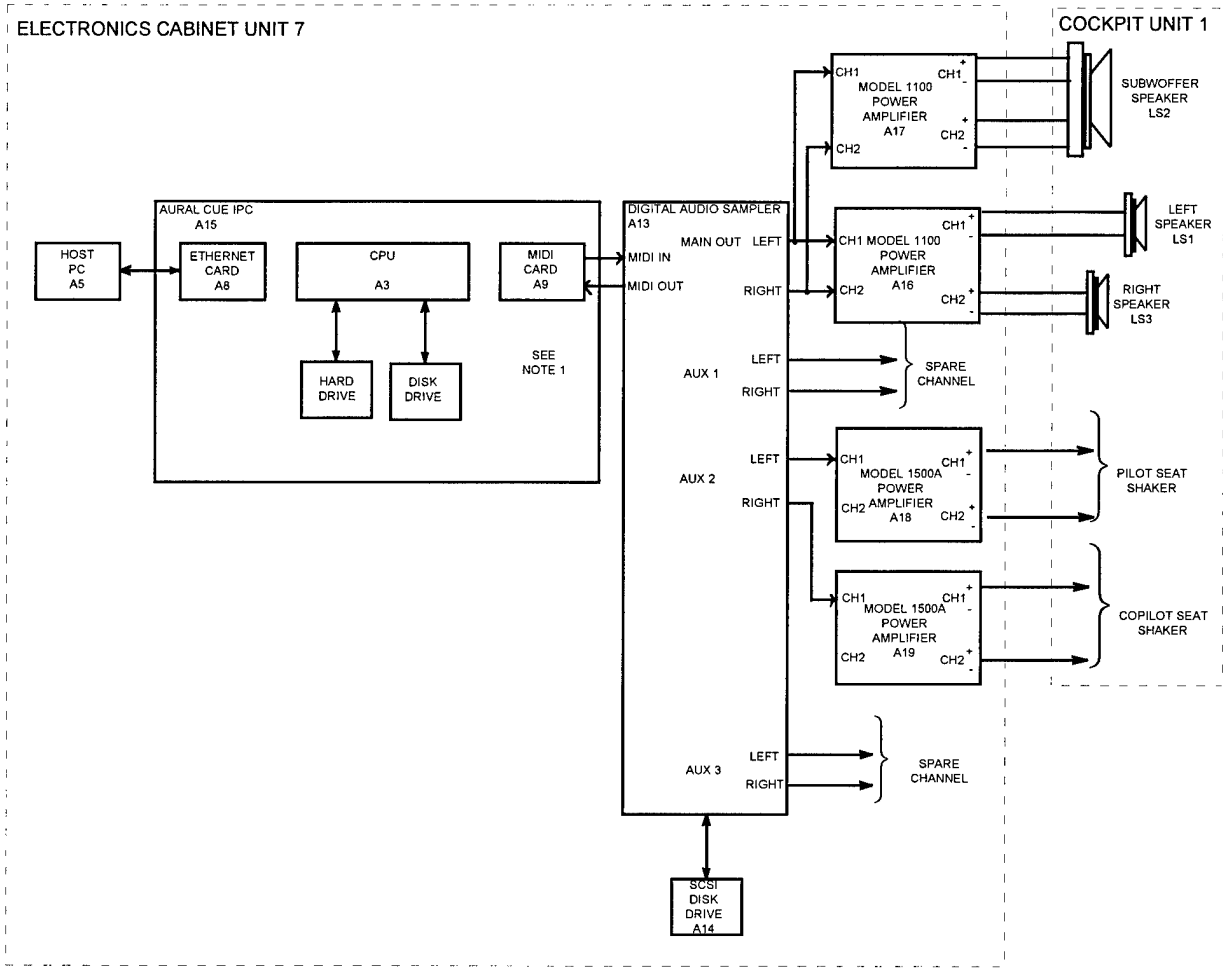

Notes:

1. Not all computer components are represented in this figure.
2. No input electrical connections are required on CH 2, but circuits are used internally since amplifier is configured for bridged operation.

Figure 4. Aural Cue/Vibration Systems, Block Diagram

2.4.2.2 Aural Cue Computer/MIDI

The Advantech IPC-610 Industrial PC chassis/computer system (aural cue computer) is a IBM PC-compatible computer and contains a 80386 DX-33 MHz microprocessor. It comes configured (by Service Integrators, Inc.) as described in paragraph 2.4.1. Reflectone has configured the IPC with an additional Music Quest musical instrument digital interface (MIDI) card in an available 16-bit expansion slot. The MIDI card is a dual-port device which provides the command and data transfers necessary to operate the audio sampler for real-time simulation and development purposes. The card is configured with the factory default I/O address switch setting (S1 position 3 on, 330) and an appropriate IRQ switch setting selected (S1 position 5 on, IRQ5).

The aural cue computer houses a 3.5-inch double-sided, double-density floppy disk drive and a non-removable hard disk drive. Hard disk storage is the only computer storage area required for normal system real-time, operation and contains the following all non-host sound generation software, all support programs used on an off-line basis for aural cue system development and maintenance (CueSonic), and vendor software. CueSonic contains real-time sound, generation, tuning, and off-line high-speed sample editing software combined in a single integrated environment. Software functions can be separated into three distinct types: sound generation files (responsible for enabling and controlling all aural cues), support files (perform development, tuning, monitor, and I/O functions), and header files (contain tables, parameters, etc.).

Files resident on the hard drive can be backed up using the floppy disk drive or tape back-up system (not provided). Connecting a spare monitor provides personnel with a means to view display parameters/data used during system maintenance, tuning, or sample editing operations.

The aural cue computer communicates with the digital sampler via the MIDI card. The MIDI card contains two input and two output channels, with only one output needed since a single dual digital sampler is used in this configuration. Sampler outputs (for MIDI inputs) are not used during real-time execution of CueSonic but are used should editing functions be performed. MIDI is a standard interface that has been agreed upon by manufacturers to allow a wide variety of instruments (musical events) to communicate with each other and with personal computers. For a detailed description of the industrial computer or MIDI card, refer to applicable vendor documentation.

2.4.2.3 Digital Audio Sampler

A single digital audio sampler (Ensoniq ASR-10R) capable of playing up to 20 voices at a time provides eight output sound channels (main and aux), all of which are used in this configuration. Depending on the complexity of the sound, specific aural cues can consist of one or more voices. The audio sampler is factory configured with two megabytes of internal RAM, creating 1 megaword of memory. Reflectone procured and

expanded memory, by installing two 8-bit non-parity D-RAM SIMMs. In order for the expanded memory to operate properly, the factor installed one-meg SIMMS and the new four-meg SIMMS were arranged so that the four-meg SIMMS are accessed first. This created an actual memory size of ten megabytes of internal memory. This additional storage area allows all of the sound files and their associated parameter blocks to be stored, eliminating the need for memory swapping during the real-time execution of CueSonic. A SCSI interface adapter is factory installed in the rack-mounted version (ASR- 10R) and allows communication between the sampler and the SCSI drive. Instrument sound files are lost when power is removed and will need to be re-loaded from the SCSI drive after power is restored. For a detailed description of the digital audio sampler, refer to the ASR-10 Musicians Manual.

The sampler contains the digital samples necessary for generating all of the aural cues for the configurable test bed. These samples are loaded from the SCSI hard drive after the sampler is powered-up and before execution of CueSonic. The ASR-IOR operating system software is located on the SCSI drive and allows the sampler to boot-up directly off the SCSI instead of floppy disk. All the sound files are located in the power-on or root directory. A bank file or macro contains a set of commands that allow the sampler to load each instrument into its proper location automatically.

Table 7 shows each specific test bed cue and the instrument where it is located. Each wavesample (ws) number is identified as a Main (Bus 1) or Aux 1, 2, or 3 output. Key Lo/Key Hi commands and number, sample rate, output, volume level, and pan values are also provided for each ws. The pan column indicates the actual panning of the cue with +99 equal to the right speakers and -99 equal to the left speakers. Numbers between -99 and +99 indicate a particular balance setting in order to locate cues in the proper direction. Not all wave samples are used in this configuration. Only samples output from Main or Aux 2 are used. Aux 1 and Aux 3 outputs are not electrically connected. This table does not define all parameters associated with each wavesample, only those that can be considered useful for description and/or maintenance. To identify parameters not provided in table, maintenance or programming personnel can use control buttons on the sampler to identify all pertinent information. Perform in accordance with applicable vendor documentation.

2.4.2.4 270 MB SCSI Disk Drive

The Ramtek SCSI Disk Drive unit is actually a dual rack mount case with a single 270 MB SCSI drive installed. It is electrically connected to the SCSI port of the digital audio sampler. A 270 MB disk cartridge contains all of the sound files and is accessed/loaded into the ASR-10R at power-up. The SCSI is not accessed during real-time execution.

2.4.2.5 Audio Power Amplifiers

Two audio power amplifiers provide enough power (approximately 50 watts per channel, with multiple 8 ohm speakers attached in parallel) to recreate the desired sound levels associated with

the test bed configurations. Both channels of one amplifier (top - A 16) are used for remote satellite speakers, and both channels of the other (bottom - A 17) are used for the remote subwoofer. Each sound is assigned a specific output channel in the digital audio sampler and transferred through power amplifiers on to the appropriate left and/or right speakers (via audio switcher box). This ensures that sounds are recreated (heard) at the accurate point of simulated sound origin. Gain controls are provided on each power amplifier but should not be used for general volume adjustment. The system's volume level is controlled with crew selections made at the cockpit management display AURAL CUE slider.

2.4.2.6 Speaker System

The test bed uses a Boston Acoustics Subsat 6 II system subwoofer and two DCM satellite speakers. They are located on the cockpit shelf holding the OTW displays. The subwoofer operates from audio amplified by the bottom Model 1 100 power amplifier (A 17) and the satellite speakers operate from audio received from the top Model 1 100 power amplifier (AI6). Main Out audio from the digital audio sampler is piggy-tailed and distributed to both amplifiers. This method ensures that the same audio is generated for both the subwoofer and satellite speakers. Left-side and/or right-side speakers function as a result of output channel assignments programmed into the audio sampler.

2.4.3 Vibration System Description

The vibration (also referred to as seat shaker) system (Figure 4.) uses various mechanical and electrical components to produce the seat movement necessary to enhance training fidelity. Movement occurs supporting normal aircraft vibration, weapons release, threat weapons near misses and impact, and ground contact. Two separate amplifiers and hardware assemblies are provided: one for the Pilot seat and one for the Copilot seat. Mechanical and electromechanical parts are located in and around the seat and electrical components are located in the electronics cabinet.

A vendor-supplied vibrator motor with associated Reflectone-designed components and hardware (vibrator assembly) is mounted and enclosed on the rear portion of both seats. The vibrator motor has a usable frequency range of 1.5 to 10,000 Hz and is controlled through electrical inputs received from the digital audio sampler and associated power amplifier. In this configuration, only low frequencies (under 20 Hz) are used.

The plunger end of the vibrator motor is mounted to a bottom plate assembly that is secured to the seat shell. The other end of the motor (top) is also connected to a mounting plate but not physically secured to the seat. Two circular shafts run through both plates and are positioned on each side of the vibrator motor. The top portion of the shafts are stationary and secured with hardware to the top plate. The other end of the shafts slide through bearing assemblies, spacers and snap rings fitted to the bottom plate. Center shaft bearings are also used in the middle area of both shafts to ensure smooth operation during motor assembly movement. Springs are

provided on both sides of the center bearing and remain in place due to attached hardware (nut/washer on top side and collar on bottom side). The springs are positioned so that the vibrator motor plunger is centered when electrical commands are absent. This mounting position allows the top plate, motor assembly, and shafts to move when the plunger is extended or retracted, exerting a force to the seat.

Table 7. Test Bed Instrument Sound Files

MPIP A1 I1 Instrument #1 1213 blks

ws#	Name	Key Lo	(#)	Key Hi	(#)	Out	Samp Rate	Vol	Vol Mod	Pan
1	Crash Expl	D5	74	D5	74	Main	17.4	99	press*99	0
2	Crash Tones	F3	53	A4	69	Main	17.4	50	press*99	0
3	Ground Cart	EF	76	E5	76	Main	29.8	70	press*99	-99
4	Air Rush	F5+	78	C6	84	Main	29.8	80	press*99	0
5	F1 Deck Air	C6+	85	F6	95	Main	29.8	99	press*99	+99
6	F1 Deck Air 2	G6	91	B6	95	Main	44.6	99	press*99	-99
7	Dort Tone 1	A4+	70	A4+	70	Main	17.4	60	press*99	+99
8	Dort Tone 2	B4	71	B4	71	Main	17.4	60	press*99	-99
9	Aux Air	C7	96	C7	96	Main	29.8	99	press*99	+99

MPIP A1 I2 Instrument #2 677 blks

ws#	Name	Key Lo	(#)	Key Hi	(#)	Out	Samp Rate	Vol	Vol Mod	Pan
1	Airburst 1	G3+	56	C4	60	Main	44.1	99	press*0	-99
2	Airburst 2	A3+	58	C4	60	Main	44.1	0	press*0	-99
3	Airburst 1	G4+	68	C5	72	Main	44.1	99	press*0	-99
4	Airburst 1	G5+	80	C6	84	Main	44.1	99	press*0	-99
5	Airburst 1	G6+	92	C7	96	Main	44.1	99	press*0	-99
6	Airburst 2	A4+	70	C5	72	Main	44.1	0	press*0	-99
7	Airburst 2	A5+	82	C6	84	Main	44.1	0	press*0	-99
8	Airburst 2	A6+	94	C7	96	Main	44.1	0	press*0	-99
9	Airburst V	G3+	56	C4	60	Aux2	44.1	99	press*0	-99
10	Airburst V	G4+	68	C5	72	Aux2	44.1	99	press*0	-99
11	Airburst V	G5+	80	C6	84	Aux2	44.1	99	press*0	-99
12	Airburst V	G6+	92	C7	96	Aux2	44.1	99	press*0	-99

Table 7. Test Bed Instrument Sound Files (Cont)

MPIP A1 I3 Instrument #3 1712 blks

ws#	Name	Key Lo	(#)	Key Hi	(#)	Out	Samp Rate	Vol	Vol Mod	Pan
1	Direct Hit 3	C4	60	C4	60	Main	29.8	99	press*0	-99
2	Direct Hit	C4	60	C4	60	Main	29.8	99	press*0	+99
3	Direct Hit 3	C5	72	C5	72	Aux1	29.8	99	press*0	-99
4	Direct Hit 3	C6	84	C6	84	Aux2	29.8	99	press*0	-99
5	Direct Hit 3	C7	96	C7	96	Aux3	29.8	99	press*0	-99
6	Direct Hit	C5	72	C5	72	Aux1	29.8	99	press*0	+9
7	Direct Hit	C6	84	C6	84	Aux2	29.8	99	press*0	+99
8	Direct Hit	C7	96	C7	96	Aux3	29.8	99	press*0	+99
9	CTT RTR 100	D4	62	D4	62	Aux2	29.8	85	press*99	0
10	CTT RTR 100	C5	72	C5	72	Aux3	29.8	85	press*99	0

MPIP A1 I4 Instrument #4 678 blks

ws#	Name	Key Lo	(#)	Key Hi	(#)	Out	Samp Rate	Vol	Vol Mod	Pan
1	Rocket	C4	60	C4	60	Main	39.1	99	press*0	0
2	Rocket	C5	72	C5	72	Aux1	39.1	99	press*0	0
3	Rocket	C6	84	C6	84	Aux2	39.1	99	press*0	0
4	Rocket	C7	96	C7	96	Aux3	39.1	99	press*0	0
5	Far Hit 1	E4	64	E4	64	Main	29.8	99	press*0	0
6	Far Hit 1	E5	76	E5	76	Aux1	29.8	99	press*0	0
7	Far Hit 1	E6	88	E6	88	Aux2	29.8	99	press*0	0
8	Far Hit 1	E7	100	E7	100	Aux3	29.8	99	press*0	0

Table 7. Test Bed Instrument Sound Files (Cont)

MPIP A1 I5 Instrument #5 683 blks

ws#	Name	Key Lo	(#)	Key Hi	(#)	Out	Samp Rate	Vol	Vol Mod	Pan
1	Gun 3	C4	60	C4	60	Main	29.8	90	press*0	0
2	Gun 3	C5	72	C5	72	Aux1	29.8	90	press*0	0
3	Gun 3	C6	84	C6	84	Aux2	29.8	90	press*0	0
4	Gun 3	C7	96	C7	96	Aux3	29.8	90	press*0	0
5	Gun 3	C4+	61	C4+	64	Main	29.8	90	press*0	0
6	Gun 3	C5+	73	C5+	76	Aux1	29.8	90	press*0	0
7	Gun 3	C6+	85	C6+	88	Aux2	29.8	90	press*0	0
8	Gun 3	C7+	97	C7+	100	Aux3	29.8	90	press*0	0
9	CTT RTR 100	B3	59	B3	76	Aux3	29.8	60	press*99	0
10	Gun 3	C4	60	C4	88	Aux2	29.8	90	press*0	0
11	Gun 3	C4+	61	C4+	100	Aux2	29.8	90	press*0	0

MPIP A1 I6 Instrument #6 1460 blks

ws#	Name	Key Lo	(#)	Key Hi	(#)	Out	Samp Rate	Vol	Vol Mod	Pan
1	Missile 1	C4	60	C4	60	Main	29.8	99	vel*99	+20
2	Lightoff1	C4	60	C4	60	Main	29.8	99	vel*99	-50
3	Missile 1	C4+	61	C4+	61	Main	29.8	99	vel*99	-20
4	Lightoff 1	C4+	61	C4+	61	Main	29.8	99	vel*99	+50
5	Missile 2	C5	72	C5	72	Main	29.8	99	vel*99	+20
6	Missile 3	C6	84	C6	84	Main	29.8	99	vel*99	+20
7	Missile 4	C7	96	C7	96	Main	29.8	99	vel*99	+20
8	Missile 2	C5+	73	C5+	73	Main	29.8	99	vel*99	-20
9	Missile 3	C6+	85	C6+	85	Main	29.8	99	vel*99	-20
10	Missile 4	C7+	97	C7+	97	Main	29.8	99	vel*99	-20
11	Lightoff 2	C5	72	C5	72	Main	29.8	99	vel*99	-50
12	Lightoff 3	C6	84	C6	84	Main	29.8	99	vel*99	-50
13	Lightoff 4	C7	96	C7	96	Main	29.8	99	vel*99	-50
14	Lightoff 2	C5+	73	C5+	73	Main	29.8	99	vel*99	+50
15	Lightoff 3	C6+	85	C6+	85	Main	29.8	99	vel*99	+50
16	Lightoff 4	C7+	97	C7+	97	Main	29.8	99	vel*99	+50

Table 7. Test Bed Instrument Sound Files (Cont)

MPIP A1 I7 Instrument #7 477 blks

ws#	Name	Key Lo	(#)	Key Hi	(#)	Out	Samp Rate	Vol	Vol Mod	Pan
1	Vibes 18	C4	60	C4	60	Aux2	29.8	99	press*99	0
2	Vibes 18	C4	60	C4	60	Aux2	29.8	99	press*99	0
3	Vibes 18	C4	60	C4	60	Aux2	29.8	99	press*99	0
4	Buffet	B3	59	B3	59	Aux2	29.8	99	press*0	0
5	Buffet	B3	59	B3	59	Aux2	29.8	99	press*0	0
6	Buffet	B3	59	B3	59	Aux2	29.8	99	press*0	0
7	Touchdown	D2+	39	D2+	39	Aux2	29.8	99	press*0	0
8	Touchdown	D2+	39	D2+	39	Aux2	29.8	99	press*0	0
9	Touchdown	D2+	39	D2+	39	Aux2	29.8	99	press*0	0
10	Vibes 18	C4	60	C4	60	Aux3	29.8	99	press*99	0
11	Vibes 18	C4	60	C4	60	Aux3	29.8	99	press*99	0
12	Vibes 18	C4	60	C4	60	Aux3	29.8	99	press*99	0
13	Buffet	B3	59	B3	59	Aux2	29.8	99	press*0	0

MPIP A1 I8 Instrument #8 482 blks

ws#	Name	Key Lo	(#)	Key Hi	(#)	Out	Samp Rate	Vol	Vol Mod	Pan
1	CTT RTR 100	C4	60	C4	60	Main	29.8	80	press*99	0
2	CTT RTR 100	C5	72	C5	72	Aux1	29.8	80	press*99	0
3	CTT RTR 100	C6	84	C6	84	Aux2	29.8	80	press*99	0

Each seat installation includes four Stabl-Level vibration mounts sandwiched between the top and bottom seat plates. The front mounts are relatively small (SLM- 1A) and support a static load of 25 to 100 lb. The rear mounts are larger (SLM-3A) and support a static load of 75 to 300 lb. All mounts are pressurized with air to create a level but movable seat. The seats are positioned on the mounts so that when the vibrator plunger moves, seat movement is not restricted by a standard fixed base.

Vibration cues are developed at the digital audio sampler and routed to each vibrator motor via one of two 1500a power amplifiers. The cues are output from the sampler's AUX 2 ports. The LEFT channel is connected to the top 1500a power amplifier (A 18) and is for the Pilot's seat. The RIGHT channel is connected to the bottom 1500a power amplifier (A1 9) and is for the Copilot's seat. For a complete list of vibration cues, refer to Table 7.

The power amplifiers are configured for bridged operation. This is required because of the high power (watts) required to drive the vibrator motors. In bridged operation, a single input channel is used but processed by both internal channels, creating three-times the power output of a single channel. Only a single output channel (CH 1) is available when operating in the bridged mode. Both amplifiers contain a gain control for each output channel. In this configuration (bridged), GAIN 2 controls should be maximized and set to 0 dB. GAIN 1 controls are then used to set the desired seat vibration level.

Cooling fans are provided to blow facility air into each seat. Two exhaust vents on each seat allow the enclosed air to circulate and escape, cooling the vibrator motors. Fan power is applied via the applicable ac distribution panel breaker and a terminal strip that is dedicated for both the ventilation blower and seat fans. This ensures that the fans run constantly unless the circuit breaker is turned off. The terminal strip is located in the forward left (as viewed from the rear) base frame.

2.5 Control Loading System

The SAIC Electro-Load (EL) is a reliable, digitally-controlled, electric-torque-motor-driven control loading (C/L) system. Electro-Load accurately simulates control stick (cyclic and collective) and pedal characteristics for a variety of mission requirements such as instrument and tactical training, aircraft familiarization, and emergency procedures.

A four axis system consisting of independent roll, yaw, pitch, and collective channels are used in this configuration. When control movement is attempted, the applied force is sensed by a load cell and converted proportionately to an electrical voltage. This resultant signal level causes the controls computer, with input from the Host PC (for friction levels, damping, and trim control), to develop the appropriate drive command. The drive command is routed to the power supply/amplifier circuits so that the necessary current signals can be developed to drive, the torque motor (p/o actuator assembly). Forces are then applied to control stick/pedal and

movement occurs via the mechanically connected actuator assembly and associated control pulleys/link-ages.

A feedback network continually adjusts for position, velocity, and updated force levels and reports this information back to the Host PC.

The Electro-Load is composed of five major subcomponents: mechanical assembly, controls computer, electric torque motor, electrical system, and feedback sensors. For a complete description, refer to applicable vendor documentation.

2.5.1 Mechanical Assemblies

The Electro-Load consists of four actuator chassis' containing a pulley drive system and output linkage, electric torque motor, and position, velocity, and force sensors. The chassis' provide a mount for the torque motor and sensors. Safety relay and signal conditioner housings are also mounted on the each actuator chassis. This self-contained mechanical assembly takes the rotary torque produced by the applicable torque motor and translates it into a force transmitted to the test bed control.

2.5.2 Controls Computer

The Electro-Load computer system (Controls IPC) performs several functions: supervises operation, computes feedback gains for the model (following control law), computes model states, monitors safety parameters, monitors and assists calibration of sensors, performs daily operational tests (DORT), and performs diagnostic and maintenance testing. The Controls IPC includes all the standard components normally associated with a PC as well as an I/O board for each channel (4) and a special VME based bus-to-bus adapter board.

2.5.2.1 I/O Cards

The I/O cards perform the necessary conversions from the analog output of the position/velocity and force sensors for the Controls IPC, and they also convert the digital command to an analog output for the amplifier. Each ISA format card provides eight digital input (DI) channels (not used in this configuration), three 16-bit analog-to-digital (A/D) channels, one digital-to-analog (D/A) channel, and one resolver-to-digital channel. Motor torque inputs, crew force input, and velocity signals are filtered and then use the A/D channels. Position inputs use the resolver-to-digital channel and the motor command output signal uses the D/A channel. Relay/amplifier enable commands are also handled by the I/O cards. Each card has a safety circuit that monitors computer operation to ensure a safe shutdown of the system should communications stop.

2.5.2.2 Bus-to-Bus Adapter Cards

The Bit 3 bus-to-bus adapter board (card) is part of the overall high-speed communication scheme (data transfer rate) between the Host PC and the Controls IPC. In this configuration, four Bit 3 adapter cards are used to provide this Shared Memory Link (SML) interface between the Host and Controls PCs: one PC/AT type card is installed in both the Host PC and Controls IPC, and two VMEbus type cards are installed in the dedicated VME chassis. This network of cards allow memory in each system to appear and be treated as if it were its own, and allows device access/control from the other system. The VME chassis and internal cards act as a junction box to connect the two PCs together under the VMEbus structure. Real-time asynchronous operation is realized without handshaking or protocol conversions. All parameters are passed through memory mapped locations as needed. Control and input parameter information is passed to Electro-Load through control locations. The Controls IPC checks information for validity and operates on it, returning status and state as required. The Controls IPC exchanges position, velocity, and force information with the Host PC when operating in real-time.

2.5.3 Torque Motors

Extremely high torque rare-earth magnet torque motors (p/o actuator assembly) are used in this configuration. Rare-earth magnet motors provide high torque-to-inertia ratio, high torque-to-power ratio, low electrical time constant, fast response, quiet/reliable operation, etc. Power to drive the torque motors comes from the associated amplifier.

2.5.4 Electrical System

The ac distribution panel assembly routes 115 Vac, single-phase power to the C/L system power supplies. Since this is a four-channel system, four power supplies and four amplifier circuits are used. Each power supply was designed specifically for use with the system's Pulse Width Modulated (PWM) amplifiers.

2.5.4.1 Dc Power Supplies

Each power supply consists of a single isolation transformer and rectifier circuit to convert the ac to dc. They are unregulated supplies that house a bleeder resistor to keep a minimum load on the supply. The tapped primary winding allows for fine tuning the output voltage under actual load conditions. Because of the requirement of peak load currents associated with servo applications, the supplies were designed to provide 1 second peak currents at 2.5 times nominal rating, with a 20% duty cycle. The resultant dc power is used by the amplifiers to drive the electric torque motors. A separate ± 15 Vdc supply is provided for the PWM amplifier turn-on logic.

2.5.4.2 PWM Amplifiers

The amplifiers employ inputs to command the desired current output. Each contain an input buffer amplifier that drives another operational amplifier functioning as a servo preamplifier.

Fixed passive components on the installed header fix the gain of the preamplifier. The output of the servo preamplifier feeds directly to a precision variable limiter. Since the limiter is immediately followed by a pulse width modulated current source, the limit level adjustment sets the output current limit of the amplifier in both source configurations. A low pass filter eliminates unwanted high frequencies. The amplifiers are protected against damage from excessive dissipation in the output transistors (from accidental shorts across load or to ground), excessive heat, or incorrect power supply voltages. In each case, the current is either limited or the drive is removed by the protection circuitry.

2.5.5 Feedback Sensors

The sensor system includes the sensor suite and associated signal conditioning circuitry. There are two sensors (sensor suite) used in this configuration to produce three signals: position/velocity resolver and force. The position/velocity sensor is a resolver operating at a 5 KHz excitation frequency. Sine and cosine output signals are decoded by a special circuit in the Controls IPC, providing very low noise position and velocity information. The force sensor is a standard tension/compression load cell attached to the actuator/control linkage. It is calibrated in both tension and compression, and has a 1000 lb. capacity. A matching instrumentation preamplifier is used to supply the sensor excitation voltage and condition the output voltage level to the required ± 10 V necessary for use by the Controls IPC analog input Circuitry.

2.6 Cockpit Components/Systems

The following paragraphs provide brief descriptions of the cockpit components/systems not already described. Items described include operational graphic panels, instrument/cockpit management PCs, instrument displays, cock-pit management display, touch screens, RGB/view video windowing system, sync combiner, and cockpit special, accessory, and stowage hardware.

2.6.1 Graphic Panels

Graphic panels are provided on the center, overhead, and side consoles for each aircraft configuration. For the most part, these panels house aircraft representative but facsimile 2-D silkscreen graphical presentations (pictures) or are simply blank panels. In some cases, however, functionality has been increased by adding active switch/indicator panel controls.

The UH-60 and AH-64 configurations have partial touch-pad, semi-interactive side or center console graphic panels. Three active touch-pad selections are available on the center console panel for the UH-60. Active switches/indicators are provided for the VHF/FM/AM Control Panel, Chaff Dispense Panel, and Radar Warning Panel. For the AB-64, one active touch-pad selection is available on the Pilot's side console panel and two on the Copilot's side console panel. Active switches/indicators are provided for the VHF/FM/AM Control Panel, Missile Control Panel, and Data Entry Keyboard.

These active switches/indicators consist of a movable plate assembly, and generally has a 2-D silk-screen of the actual aircraft component. If the functional control is momentarily pressed, internal switch contacts close and a true DI condition is sent to the Host PC (via I/O system). The host responds by directing cockpit management (center console) PC to display an isolated view of the selected panel/keyboard. It also illuminates an associated panel indicator (true DO condition returned) to show personnel that the panel has been selected. From this displayed pop-up view, crew members can manipulate active panel functions via the cockpit management touch screen.

2.6.2 Instrument/Cockpit Management Display System

The following paragraphs provide brief description of the components associated with the Instrument/Cockpit Management Display System.

2.6.2.1 Instrument/Cockpit Management PCs

The instrument and cockpit management PCs are all Pentium-driven IBM-compatible computers that operate under the Microsoft Windows NT environment to produce visual presentations of all aircraft-specific instruments. A separate PC is provided for each instrument/cockpit management display (4). No special application cards are required to support this function. Each computer is stuffed with normal PC-related components, with specific attention given to video card type. This ensures that fast, high quality video images could be produced under this environment.

HS, VS, and RGB video is routed from the applicable video card directly to the center instrument and cockpit management displays, and to a sync combiner (converts to RGB and then routes to RGB/View Video Windowing System for possible video overlay) for the left and right instrument displays. The touch screens are electrically connected to each PC via a RS232 port. In addition, an Ethernet card provides the interface between the Host and instrument/cockpit management PCs. A second RS232 connection is shown as an output in Figure 1 but not used at this time. This is a future enhancement so that the Barco displays can be remotely adjusted.

2.6.2.2 Instrument Displays

All front panel aircraft-specific instruments are represented by animated graphical displays of approximately the same size and position of the aircraft instruments being simulated. These graphical representations become partially functional through the use of a touch screen that has been mounted on top of each CRT.

There are three 29" high resolution color Barco CRT instrument displays (monitors): the left instrument, center instrument, and right instrument displays. HS, VS, and RGB video is developed for monitor use by the associated PC's video card. It is routed either straight to the display or via a sync combiner unit and a RGB/View Video Windowing System. The left and right instrument displays receive RGB video from two independent sync combiners/windowing

systems. These sync combiner units take PC-generated HS, VS, and RGB video inputs and convert the signals to the RGB (sync on green) format. This is required to support the RGB/View Video Windowing System requirements of injecting a video overlay on top of the instrument panel's displayed graphical presentation. The monitors display at a resolution of 1280 by 1024. The left and right monitors use a RGB (sync on green) cable connections on the rear panel, and are switched for internal sync. The center instrument panel uses HS, VS, and RGB cable connections and is switched for external sync. Each monitor is terminated (by switches) as the last input device.

2.6.2.3 Cockpit Management Display

The cockpit management (center console) display uses a 19" Sassi monitor. A touch screen is mounted on the face of the CRT to allow control for the normal instrument selection, as well as allow for simulation control display selections. The cockpit management display is mounted in the upper center console area in one of two locations. For the UH-60 and AH-64 aircraft configurations, the monitor is positioned in a normal monitor fashion with the bezel (case) cutout in the lower right position. Handles are at the left and right positions and can be removed after installation to better facilitate training. The monitor is placed in the full aft position with a single closeout required/mounted above the monitor. For the OH58D aircraft configuration, the monitor is positioned vertically with the bezel (case) cutout in the top right position. Handles are at the top and bottom positions and can be removed to better facilitate training. The monitor is placed in the center position with a closeout required/mounted on each side of monitor.

The Sassi monitor uses HS, VS, and RGB video generated from the cockpit management PC to display graphics (instrument or simulation control pages) at a resolution of 1280 by 1024.

2.6.2.4 Touch screens

Each of the onboard instrument displays have a touch screen assembly mounted to the face of the monitor. These touch screens have been installed using adhesive strips and tape. The touch screens are an alternate input device that uses a RS232 interface to communicate with its connected PC. They require and come with an external controller module that has been physically mounted near the back of each display. When a user touches the face of the touch screen (with finger), the applicable x and y coordinates are sent to the controlling PC. The PC responds by positioning the cursor or selecting the instrument at the point touched.

The touch screen is the only method available on the test bed for operational mode instrument selection, activation, and control. In addition, the touch screen located on the cockpit management display provides a means for the operator to select the available simulation control features. For operating procedures, refer to Chapter 2. For touch screen calibration procedures, refer to Chapter 4.

2.6.2.5 RGB/View Video Windowing System

The RGB/View Video Windowing System is installed in the system to provide real-time video overlays on top of the instrument graphical presentation. This feature is used to display sensor images on the OH-58D and AH-64 Pilot and Copilot MFDs or VDUS. It takes high resolution RGB video received from the sync combiner (representing instrument presentations) and combines it with RGB video (if present) prior to being input to the display. The windowing system provides front panel controls that have been set and stored for positioning the overlays.

2.6.3 Cockpit Special, Accessory, and Stowage Hardware

Cockpit special, accessory, and stowage hardware is provided on the cockpit to support test bed functionality and simplicity requirements. This includes items such as stowage compartments, boarding/egress handles, HMD cooling fan. Grimes lights, keyboard jack assemblies, and recirculating blower.

2.6.3.1 Stowage Compartments

Stowage compartments are built-in to the cockpit structure and provide areas for stowing the hardware panels associated with the un-installed aircraft configurations. The center console provides a stowage area for the unused center console panels and the close-outs associated with cockpit management display positioning. It is accessed through the rear plate and provides guides for the panel assemblies. Close-outs are placed in the bottom of the stowage compartment. Each side console provides an area for unused side panels. They also are accessed through the rear plates and provide guides for the panel assemblies. Overhead panels are stowed on top of the overhead panel itself. They are secured in place via hardware. Unused bezels (instrument overlays) can be placed in a customer designated area (preferred method) or in a stowage area located at the very top of cockpit structure. This area is somewhat inconvenient, but provides the only possible place to stow the large bezel assemblies.

2.6.3.2 Boarding/Egress Handles

Both the Pilot and Copilot positions have boarding/egress handles installed directly above the corners of the bezel assembly (lower corners of instrument display closeout). These handles are provided to ensure a safe entrance and exit to/from the cockpit.

2.6.3.3 HMD Fan Assembly

A HMD fan assembly is provided to direct air at the Pilot's face area when wearing the HMD. This helps provide the circulation required to ensure Pilot comfort while wearing the prototype helmet. The fan's electrical connector must be physically plugged-in to operate.

2.6.3.4 Grimes Lights

A Grimes light assembly is provided for the Pilot and Copilot and are located directly above the corners of the bezel assembly (lower corners of instrument display closeout). These 28-volt lights are provided to ensure a safe entrance and exit to/from the cockpit, and also for general crew needs. The lights are adjustable and connected directly to the ac distribution panel assembly. This ensures that they are always powered and available for crew use.

2.6.3.5 Keyboard Jack Assemblies

Keyboard jacks are provided in the cockpit for PC-related operation/maintenance purposes. Four jacks are provided: two on the Pilot side console and two on the center pedestal/console (Copilot side). The jacks (J2/J3) on the Pilot side console are for connecting the right instrument (top jack) and cockpit management (bottom jack) display PCs to an onboard keyboard. The jacks (J2/J3) on the center console are provided for connecting to the left (top jack) instrument and center (bottom jack) instrument display PCs to an onboard keyboard.

2.6.3.6 Recirculating Blower

A recirculating powered blower cage is mounted in the cockpit base frame and circulates air around the instrument and OTW displays. Air travels through a specially designed air flue assembly and escapes via vent holes in the enclosure. The blower motor receives power directly from an ac distribution panel assembly load center breaker (CB 19).

2.7 Network Interface

Network communications are provided via an Ethernet/Distributed Interactive Simulation (DIS) interface. The ARMS-TB meets DIS interoperability standards for other DIS Version 2.0.4 compatible devices (both real and computer generated). For a brief description, refer to following paragraphs.

2.7.1 Ethernet/DIS Interface

Data is shared/interfaced locally between all satellite PCs, the aural cue IPC, and the image generator on a 32-bit Ethernet system. Each PC and the IPC contains at least one PCI or ISA based Ethernet adapter card.

A Cabletron Systems multipart Ethernet/IEEE repeater unit is provided in the electronics cabinet for isolating and monitoring the Ethernet system. This unit eliminates the need for daisy-chaining the complete Ethernet system, thereby providing separation should problems arise with a particular Ethernet card/cable. The multipart Ethernet/IEEE repeater is capable of interfacing eight BNC type connections and one 15-pin D-type connection (9-Channels).

Thin coaxial cable is routed in a continuous manner to each electronic cabinet PC/IPC Ethernet adapter board's BNC (IOBase-2) connection using appropriate T-connectors. Termination is provided at the host computer's T-connector. The other end of the daisy-chained line is connected to a single channel on the multipart Ethernet/IEEE repeater unit.

Thin coaxial cable is also routed from the multipart unit to each of the cockpit PCs. The only difference is that they are not all daisy-chained together. A single cable with appropriate termination is connected directly to the multipart unit for each PC. This type of connection uses four more channels on the multipart unit.

A single multipart unit channel is reserved for the image generator. At the end of this cable, a microtransceiver module (CentreCOM MX10s) is attached and converts the coaxial cable to a 15-pin D-style AUI connector. An extension cable is then connected to the microtransceiver module and routed to the Network port on the image generator. The microtransceiver module contains a status and power indicator that is lit green to indicate that heartbeat is selected off and line power is applied. The multipart Ethernet/IEEE repeater unit's channel assignments are as follows:

- Channel 1 Host PC, PDU Filter PC, Aural Cue IPC, and COM PC (Daisy-Chained)
- Channel 2 Not Used
- Channel 3 Right Instrument PC
- Channel 4 Cockpit Management PC
- Channel 5 Center Instrument PC
- Channel 6 Image Generator
- Channel 7 Left Instrument PC
- Channel 8 Not Used
- Channel 9 Not Used

The test bed incorporates a stand-alone PC (PDU Filter PC) for filtering unwanted Protocol Data Units (PDUs) and decoding PDUs on the DIS network. The PC and its internal software ensures that local (test bed) Ethernet/non-PDU traffic does not pass to other simulation systems, and external (other DIS connected systems) Ethernet/non-PDU traffic does not pass to the test bed equipment. This prevents negative time related (bandwidth) problems associated with internally processing excessive non-essential Ethernet/non-PDU traffic. In addition to the filtering of non-PDU traffic, the system also discriminates between the types of PDUs allowed into the test bed. PDUs currently allowed and passed include Entity State, Fire, Detonation, and Emission. The test bed generates and passes Entity State, Fire, and Detonation on the DIS network for use by other simulation devices. The PDU Filter PC builds a record table to keep track of all active Entity States. It uses this information to ensure that only the eight closest emitting entities are passed into the test bed.

The Comm system uses dual Ethernet cards to communicate both directly with the external DIS network and internally on the Ethernet/DIS network.

2.8 Digital Communication System

The Advanced Simulation Technology, Inc. (ASTI) Digital Communications (Comm) System is a stand-alone PC-based system that communicates with the Host PC and DIS network via Ethernet. The ASTI system directly interfaces to all headsets and microphones via jacks on the Pilot side console (for Pilot), center console (for Copilot) and HMD. In addition, two jacks are wired externally on the electronics cabinet and provide a means for observers to monitor crew audio. Audio is routed to these jacks directly from the 8-channel waveform synthesizer card. The PC contains customized software to build and run simulation models. These models can replicate Intercom audio, radio transmissions, and aural cues for aircraft system sounds (tones). The system also has DEMO and Daily Operational Readiness Test (DORT) capability. Recorded communication voice audio can be recorded by a connected dual cassette player. At time of publication, cockpit Pilot and Copilot footswitches are active for the AH-64 configuration only.

The ASTI system consists of a rack mounted industrial PC containing the following: 100 MHz Pentium CPU card, 500 MB hard drive, two 3.5-inch floppy drives, ASTI 8-channel waveform synthesizer card, and two Ethernet cards. There are no hardware adjustments to this system. All gain settings are software controlled. The maximum signal levels into and out of the waveform synthesizer are as follows:

Input levels	+/- 1.5V maximum
Input impedance	20 KOhms, Balanced
Output levels	+/- 3V maximum
Output impedance	600 Ohms

The PC runs DOS 6.22 and is loaded with ASTI provided model builder software. Refer to the ASTI Digital Audio System Documentation manual for details of software. Three software disks are supplied with the system: Model Builder Installation Disk, Model Builder Utilities Disk, and Software Protection Key Code Disk.

The model builder software has a built-in protection. The Ethernet card hardware address is encoded on the Key Code Disk and the system will not run if this card is changed without obtaining a new Key Code Disk from ASTI.

NOTE

The Comm system automatically boots when power is applied. The following paragraphs are provided for reference only, and are applicable if a monitor and keyboard is connected to the PC.

Upon system power up a menu screen is presented for startup selection. The choices are:

- 1 . Start the configured model (default if no selection is made in 10 seconds).

2. Start the configured DEMO model.
3. DOS.

If number 1 is selected or 10 seconds have elapsed with no keyboard selection, the model builder program is started and the trainer model configuration startup file specified in C:autoexec.bat is executed. For the test bed, the model startup configuration file is C:MBUILDER\USER\N40DELS\ARMS_TC.CFG.

If number 2 is selected the model builder program is started and the DEMO model configuration startup file specified in C:autoexec.bat is executed. For the test bed, the model startup configuration file is C:MBUILDER\DEMO\MODELS\DEMO.CFG.

The configuration startup files contain all information about how the system hardware is to be configured. This includes setup of the Ethernet cards for the Host and DIS interface, setup of the microphone input gains, starting the model, identifying that a waveform synthesizer is in the system, and identifying where the sound directory is located.

Once the model is started, all parameters required to control the audio simulation are passed from the Host PC via Ethernet. The data and Ethernet status can be viewed at any time using the terminal tied (if connected) to the ASTI system. The status and data from the DIS Ethernet card can also be viewed in real time from the local terminal. Refer to the ASTI Digital Audio System Documentation manual for operation of all menus and configuration requirements.

All parameters have the capability of being set to a local test mode so a local test parameter can be input to check out the system. There are also default varies that can be set to ensure default operation (hot mike ICS) if the Host PC or Ethernet quit operating. Ensure that you save any changes to the model before you exit the model builder program or they will be lost. Test settings are not saved.

2.9 Software Configuration

The ARMS-TC contains a mixture of Generic COTS and Reflectone designed COTS software. Under the contractual agreement only the executable programs are part of the delivered device. All source code is considered proprietary.

Since the ARMS-TC relies heavily on distributed processing there are 10 different computational systems to consider:

- 1- Host PC
- 2- Left Instrument Display PC
- 3- Center Instrument Display PC
- 4- Right Instrument Display PC

- 5- Console Instrument Display PC
- 6- PDU Filter PC
- 7- Aural Cue PC
- 9- Controls PC
- 10- SGI Image Generator

2.9.1 Host PC

The Host PC executable is named *mpip.exe* (or it's identical copy, *arms.exe*). The latest tested version of the S/W load exists in the C:\GREEN directory. Besides the DOS operating system, it is the only required file to start the host software load. For reference, the following object file list and file dependency is provided. Note that this does not imply that these source files are available to the user and in most cases uncompiled source will not exist on the PC.

2.9.1.1 FORTRAN Modules:

NAVINIT.OBJ: NAVINIT.FOR XRDPDAT.INC NAVIONIC.INC WMMS.INC
 ZDCOMIN.OBJ: ZDCOMIN.FOR XRDPDAT.INC AVIONIC.INC XIDIS.INC
 LL2UTM.FOR CINTBH.FOR SNEPC.FOR SNEPCR.FOR
 NDOPLR58.OBJ: NDOPLR58.FOR XRDPDAT.INC NAVIONIC.INC LL2UTM.FOR
 SNEPC.FOR
 NDOPLR60.OBJ: NDOPLR60.FOR XRDPDAT.INC NAVIONIC.INC LL2UTM.FOR
 CINTBH.FOR SNEPC.FOR
 NWPTCTL.OBJ: NWPTCTL.FOR XRDPDAT.INC NAVIONIC.INC LL2UTM.FOR
 CINTBH.FOR
 WVMMS.OBJ: WVMMS.FORXRDPDAT.INCXIENTTBL.INCWMMMS.INC
 NAVIONIC.INC WTACTICS.INC SNEPC.FOR
 WPAPR_39.OBJ: WPAPR_39.FOR XRDPDAT.INC NAVIONIC.INC WTACT.INC
 ZMFDCTL.OBJ: ZMFDCTL.FOR XRDPDAT.INC NAVIONIC.INC WMMS.INC
 WTACT.INC
 WMARM.OBJ: WMARM.FOR XRDPDAT.INC XIENTTBL.INC NAVIONIC.INC
 WMMS.INC WTACT.INC WTACTICS.INC
 WMARM64.OBJ: WMARM64.FOR XRDPDAT.INC XIENTTBL.INC NAVIONIC.INC
 WMMS.INC WTACT.INC WTACTICS.INC APACHE.INC
 WVTADS.OBJ: WVTADS.FOR XRDPDAT.INC XIENTTBL.INC NAVIONIC.INC
 WMMS.INC WTACT.INC WTACTICS.INC APACHE.INC
 ZAHSYM.OBJ: ZAHSYM.FOR XRDPDAT.INC XIENTTBL.INC NAVIONIC.INC
 WMMS.INC WTACT.INC WTACTICS.INC APACHE.INC
 SNEPC.OBJ: SNEPC.FOR XRDPDAT.INC
 SNEPCR.OBJ: SNEPCR.FOR XRDPDAT.INC
 CINTBH.OBJ: CINTBH.FOR

LL2UTM.OBJ: LL2UTM.FOR XRDPDAT.INC CINTBH.FOR
 UTM2LL.OBJ: UTM2LL.FOR XRDPDAT.INC
 NDIGITBH.OBJ: NDIGITBH.FOR
 UMBUF.OBJ: UMBUF.FOR XRDPDAT.INC NAVIONIC.INC WTACT.INC
 DIGITBH.OBJ: DIGITBH.FOR
 WMINIT.OBJ: WMINIT.FOR XRDPDAT.INC NAVIONIC.INC WMMS.INC
 WTACT.INC WTACTICS.INC XIENTTBL.INC
 ZMFDSYM.OBJ: ZMFDSYM.FOR XRDPDAT.INC NAVIONIC.INC WMMS.INC
 WTACT.INC
 KICTRL.OBJ: KICTRL.FOR XRDPDAT.INC KCOMM.INC NAVIONIC.INC
 KVCTRL.OBJ: KVCTRL.FOR XRDPDAT.INC KCOMM.INC NAVIONIC.INC
 XRDCSOUT.OBJ: XRDCSOUT.FOR XRDPDAT.INC KCOMM.INC XIDIS.INC
 NAVIONIC.INC WTACTICS.INC
 K_INIT.OBJ: K_INIT.FOR XRDPDAT.INC KCOMM.INC
 MSN60_1.OBJ: MSN60_1.FOR NAVIONIC.INC XRDPDAT.INC
 MSN60_2.OBJ: MSN60_2.FOR NAVIONIC.INC XRDPDAT.INC
 MSN60_3.OBJ: MSN60_3.FOR NAVIONIC.INC XRDPDAT.INC
 MSN60_4.OBJ: MSN60_4.FOR NAVIONIC.INC XRDPDAT.INC
 MSN60_5.OBJ: MSN60_5.FOR NAVIONIC.INC XRDPDAT.INC
 MSN60_6.OBJ: MSN60_6.FOR NAVIONIC.INC XRDPDAT.INC
 MSN60_7.OBJ: MSN60_7.FOR NAVIONIC.INC XRDPDAT.INC
 MSN60_8.OBJ: MSN60_8.FOR NAVIONIC.INC XRDPDAT.INC
 MSN58_1.OBJ: MSN58_1.FOR NAVIONIC.INC XRDPDAT.INC
 MSN58_2.OBJ: MSN58_2.FOR NAVIONIC.INC XRDPDAT.INC
 MSN58_3.OBJ: MSN58_3.FOR NAVIONIC.INC XRDPDAT.INC
 MSN58_4.OBJ: MSN58_4.FOR NAVIONIC.INC XRDPDAT.INC
 MSN58_5.OBJ: MSN58_5.FOR NAVIONIC.INC XRDPDAT.INC
 MSN58_6.OBJ: MSN58_6.FOR NAVIONIC.INC XRDPDAT.INC
 MSN58_7.OBJ: MSN58_7.FOR NAVIONIC.INC XRDPDAT.INC
 MSN58_8.OBJ: MSN58_8.FOR NAVIONIC.INC XRDPDAT.INC
 MSN64_1.OBJ: MSN64_1.FOR NAVIONIC.INC XRDPDAT.INC
 MSN64_2.OBJ: MSN64_2.FOR NAVIONIC.INC XRDPDAT.INC
 MSN64_3.OBJ: MSN64_3.FOR NAVIONIC.INC XRDPDAT.INC
 MSN64_4.OBJ: MSN64_4.FOR NAVIONIC.INC XRDPDAT.INC
 MSN64_5.OBJ: MSN64_5.FOR NAVIONIC.INC XRDPDAT.INC
 MSN64_6.OBJ: MSN64_6.FOR NAVIONIC.INC XRDPDAT.INC
 MSN64_7.OBJ: MSN64_7.FOR NAVIONIC.INC XRDPDAT.INC
 MSN64_8.OBJ: MSN64_8.FOR NAVIONIC.INC XRDPDAT.INC
 ASOUND.OBJ: ASOUND.FOR AMVMIXER.INC XRDPDAT.INC WTACTICS.INC
 ASOUND.INC XIENTTBL.INC DTGLOBAL.INC XCOMMON.INC
 ASFLYBY.OBJ: ASFLYBY.FOR WTACTICS.INC XRDPDAT.INC XIENTTBL.INC
 D_FINI.OBJ: D_FINI.FOR XRDPDAT.INC Q_TEXT.INC

D_INIT.OBJ: D_INIT.FOR XRDPDAT.INC Q_TEXT.INC
 DTINPUT.OBJ: DTINPUT.FOR XRDPDAT.INC Q_TEXT.INC CL.INC
 DTPAGE.OBJ: DTPAGE.FOR XRDPDAT.INC Q_TEXT.INC
 DTUPDATE.OBJ: DTUPDATE.FOR XRDPDAT.INC Q_TEXT.INC ASOUND.INC
 CL.INC
 EIND.OBJ: EIND.FOR XRDPDAT.INC
 F_INIT.OBJ: F_INIT.FOR XRDPDAT.INC
 FYFLY.OBJ: FYFLY.FOR XRDPDAT.INC XCOMMON.INC
 LFUEL.OBJ: LFUEL.FOR XRDPDAT.INC
 NRADALT.OBJ: NRADALT.FOR XRDPDAT.INC
 Q_BATR.OBJ: Q_BATR.FOR
 Q_BOX.OBJ: Q_BOX.FOR
 Q_DINT.OBJ: Q_DINT.FOR
 Q_DREAL.OBJ: Q_DREAL.FOR
 Q_HEX.OBJ: Q_HEX.FOR
 Q_HEX5.OBJ: Q_HEX5.FOR
 Q_INT.OBJ: Q_INT.FOR
 Q_REAL.OBJ: Q_REAL.FOR
 S_INIT.OBJ: S_INIT.FOR XRDPDAT.INC ASOUND.INC
 SSWAP.OBJ: SSWAP.FOR
 VBIRD.OBJ: VBIRD.FOR XRDPDAT.INC VISUAL.INC
 VFORMAT.OBJ: VFORMAT.FOR XRDPDAT.INC VISUAL.INC
 W_INIT.OBJ: W_INIT.FOR XRDPDAT.INC XCOMMON.INC XIENTTBL.INC
 XIDETTL.INCXIFIRTBL.INCWTACTICS.INC
 WMCANNON.OBJ: WMCANNON.FOR XINTFACE.INC XRDPDAT.INC
 XCOMMON.INC XIENTTBL.INC WTACTICS.INC WTACT.INC
 WMISSILE.OBJ: WMISSILE.FOR XINTFACE.INC XRDPDAT.INC XCOMMON.INC
 XIENTTBL.INC WTACTICS.INC WTACT.INC
 WMROCKET.OBJ: WMROCKET.FOR XINTFACE.INC XRDPDAT.INC XCOMMON.INC
 XIENTTBL.INC WTACTICS.INC WTACT.INC
 WMCHAFF.OBJ: WMCHAFF.FOR XRDPDAT.INC XIESPDU.INC WTACT.INC
 XIDIS.INC
 WPASE.OBJ: WPASE.FOR XRDPDAT.INC XCOMMON.INC XIENTTBL.INC
 XIDETTL.INC XIFIRTBL.INC WTACTICS.INC
 XRACUOUT.OBJ: XRACUOUT.FOR ASOUND.INC
 XRACUIN.OBJ: XRACUIN.FOR XRDPDAT.INC XRNIO.INC
 XRCHKSUM.OBJ: XRCHKSUM.FOR
 XREAINIT.OBJ: XREAINIT.FOR XRNETADR.INC
 XRJOYINI.OBJ: XRJOYINI.FOR XRDPDAT.INC
 XRINSOUT.OBJ: XRINSOUT.FOR XRDPDAT.INC NAVIONIC.INC WTACT.INC
 WMMS.INC KCOMM.INC CSTUFF.C
 XRINSIN.OBJ: XRINSIN.FOR XRDPDAT.INC XRNIO.INC NAVIONIC.INC
 WTACT.INC WMMS.INC KCOMM.INC

XRCPMOUT.OBJ: XRCPMOUT.FOR XRDPDAT.INC NAVIONIC.INC WTACT.INC
XRCPMIN.OBJ: XRCPMIN.FOR XRDPDAT.INC XRNIO.INC NAVIONIC.INC
WTACT.INC KCOMM.INC apache.inc
XRNINIT.OBJ: XRNINIT.FOR
XRNETIN.OBJ: XRNETIN.FOR XRDPDAT.INC XRNIO.INC XRNETADR.INC
VISUAL.INC
XRNETWR.OBJ: XRNETWR.FOR XRNETADR.INC
XRSWAP.OBJ: XRSWAP.FOR
XRTIN.OBJ: XRTIN.FOR XRDPDAT.INC XCOMMON.INC CL.INC apache.inc
XRTOUT.OBJ: XRTOUT.FOR XRDPDAT.INC XCOMMON.INC
XRVISIN.OBJ: XRVISIN.FOR XRDPDAT.INC XRNIO.INC NAVIONIC.INC
WMMS.INC WTACT.INC
XRVISOUT.OBJ: XRVISOUT.FOR XRDPDAT.INC XIENTTBL.INC WTACTICS.INC
VISUAL.INC WTACT.INC WMMS.INC NAVIONIC.INC
TVCOMMON.INC
DJDEBUG.OBJ: DJDEBUG.FOR XRDPDAT.INC DJDPAG00.FOR DJDPAG01.FOR
DJDPAG02.FOR DJDPAG03.FOR DJDPAG04.FOR DJDPAG05.FOR
DJDPAG06.FOR DJDPAG07.FOR DJDPAG08.FOR DJDPAG09.FOR
DJDPAG00.OBJ: DJDPAG00.FOR XRDPDAT.INC XIENTTBL.INC WTACTICS.INC
XCOMMON.INC XIDIS.INC VISUAL.INC XRNETADR.INC
WTACT.INC
DJDPAG01.OBJ: DJDPAG01.FOR XRDPDAT.INC XIENTTBL.INC WTACTICS.INC
XCOMMON.INC XIDIS.INC VISUAL.INC XRNETADR.INC
DJDPAG02.OBJ: DJDPAG02.FOR XRDPDAT.INC XIENTTBL.INC WTACTICS.INC
XCOMMON.INC XIDIS.INC VISUAL.INC XRNETADR.INC
DJDPAG03.OBJ: DJDPAG03.FOR XRDPDAT.INC XIENTTBL.INC WTACTICS.INC
XCOMMON.INC XIDIS.INC VISUAL.INC XRNETADR.INC
DJDPAG04.OBJ: DJDPAG04.FOR XRDPDAT.INC XIENTTBL.INC WTACTICS.INC
XCOMMON.INC XIDIS.INC VISUAL.INC XRNETADR.INC
DJDPAG05.OBJ: DJDPAG05.FOR XRDPDAT.INC XIENTTBL.INC WTACTICS.INC
XCOMMON.INC XIDIS.INC VISUAL.INC XRNETADR.INC
DJDPAG06.OBJ: DJDPAG06.FOR XRDPDAT.INC XIENTTBL.INC WTACTICS.INC
XCOMMON.INC XIDIS.INC VISUAL.INC XRNETADR.INC
DJDPAG07.OBJ: DJDPAG07.FOR XRDPDAT.INC XIENTTBL.INC WTACTICS.INC
XCOMMON.INC XIDIS.INC VISUAL.INC XRNETADR.INC
WTACT.INC
DJDPAG08.OBJ: DJDPAG08.FOR XRDPDAT.INC XIENTTBL.INC WTACTICS.INC
XCOMMON.INC XIDIS.INC VISUAL.INC XRNETADR.INC
DJDPAG09.OBJ: DJDPAG09.FOR XRDPDAT.INC XIENTTBL.INC WTACTICS.INC
XCOMMON.INC XIDIS.INC VISUAL.INC XRNETADR.INC
CL.INC

2.9.1.2 DIS Modules:

XIDISEXT.OBJ: XIDISEXT.FOR XINTFACE.INC XIESPDU.INC
 XIDRALG2.OBJ: XIDRALG2.FOR XRDPDAT.INC
 XIDRALG3.OBJ: XIDRALG3.FOR XRDPDAT.INC
 XIDRALG4.OBJ: XIDRALG4.FOR XRDPDAT.INC
 XIDRENTB.OBJ: XIDRENTB.FOR XIENTTBL.INC XINTFACE.INC
 XILDDEPD.OBJ: XILDDEPD.FOR WTACTICS.INC XIDETPDU.INC
 XILDESPD.OBJ: XILDESPD.FOR WTACTICS.INC XIESPDU.INC
 XILDFIPD.OBJ: XILDFIPD.FOR WTACTICS.INC XIFIRPDU.INC
 XISTDEPD.OBJ: XISTDEPD.FOR XINTFACE.INC XRDPDAT.INC XIDETPDU.INC
 XIDETPDU.INC
 XIDETTBL.INC
 XISTESPD.OBJ: XISTESPD.FOR XINTFACE.INC XRDPDAT.INC XIESPDU.INC
 XIENTTBL.INC XIDIS.INC
 XISTEMPD.OBJ: XISTEMPD.FOR XINTFACE.INC XRDPDAT.INC XIEMIPDU.INC
 XIEMITBL.INC XIENTTBL.INC XIDIS.INC
 XISTFIPD.OBJ: XISTFIPD.FOR XINTFACE.INC XRDPDAT.INC XIFIRPDU.INC
 XIFIRTBL.INC
 XIRCVCOL.OBJ: XIRCVCOL.FOR XRDPDAT.INC XICOLPDU.INC XIENTTBL.INC
 XIRCVFRZ.OBJ: XIRCVFRZ.FOR XRDPDAT.INC XIFRZPDU.INC
 XIRCVRES.OBJ: XIRCVRES.FOR XRDPDAT.INC XIRES PDU.INC
 XISWPDET.OBJ: XISWPDET.FOR XIDETPDU.INC
 XISWPES.OBJ: XISWPES.FOR XIESPDU.INC
 XISWPFIR.OBJ: XISWPFIR.FOR XIFIRPDU.INC
 XISWPEMI.OBJ: XISWPEMI.FOR XIEMIPDU.INC
 XISWPCOL.OBJ: XISWPCOL.FOR XICOLPDU.INC
 XISWPFIRZ.OBJ: XISWPFIRZ.FOR XIFRZPDU.INC
 XISWPRES.OBJ: XISWPRES.FOR XIRES PDU.INC
 XISWPACK.OBJ: XISWPACK.FOR XIACKPDU.INC
 XIUDLENT.OBJ: XIUDLENT.FOR XRDPDAT.INC XIENTTBL.INC XIESPDU.INC
 WTACTICS.INC
 XIDRLENT.OBJ: XIDRLENT.FOR XRDPDAT.INC XIENTTBL.INC XIDIS.INC
 XIUPENTB.OBJ: XIUPENTB.FOR XIENTTBL.INC
 XIWRDEPD.OBJ: XIWRDEPD.FOR XIDETPDU.INC XIDIS.INC
 XIWRESPD.OBJ: XIWRESPD.FOR XIESPDU.INC XIDIS.INC
 XIWRFIPD.OBJ: XIWRFIPD.FOR XIFIRPDU.INC XIDIS.INC
 XIWRCOPD.OBJ: XIWRCOPD.FOR XICOLPDU.INC XIDIS.INC
 XIWRAKPD.OBJ: XIWRAKPD.FOR XIACKPDU.INC XIDIS.INC
 XIDISIN.OBJ: XIDISIN.FOR
 X_INIT.OBJ: X_INIT.FOR XRDPDAT.INC XINTFACE.INC XIENTTBL.INC
 XIDISTMR.OBJ: XIDISTMR.FOR
 XICLDIEN.OBJ: XICLDIEN.FOR XIENTTBL.INC
 XICOLLID.OBJ: XICOLLID.FOR XRDPDAT.INC XICOLPDU.INC XIDIS.INC
 XIENTTBL.INC

XINXTEVT.OBJ: XINXTEVT.FOR
 XINXTENT.OBJ: XINXTENT.FOR
 XISWPER.OBJ: XISWPER.FOR XIEVNTPD.INC
 XIWRERPD.OBJ: XIWRERPD.FOR XIEVNTPD.INC XIDIS.INC
 XIEVENTS.OBJ: XIEVENTS.FOR XIEVNTPD.INC XRDPDAT.INC XIDIS.INC

2.9.1.3 "C" Modules:

xiconvrt.obj: xiconvrt.c
 clrt.obj: clrt.c cl_link.h cl_link2.h cl_host.h
 xrtdio.obj: xrtdio.c
 xriopack.obj: xriopack.for xcommon.inc
 xrbit3i.obj: xrbit3i.c
 cstuff.obj: cstuff.c
 vbcmd.obj: vbcmd.c vbird.h asctech.h
 vbore.obj: vbore.c vbird.h asctech.h
 vbhem.obj: vbhem.c vbird.h asctech.h
 xrai_rt.obj: xrai_rt.c

2.9.1.4 Assembler modules:

Q_GETJOY.OBJ: Q_GETJOY.ASM
 Q_GETKEY.OBJ: Q_GETKEY.ASM
 Q_GETTCH.OBJ: Q_GETTCH.ASM
 Q_HATR.OBJ: Q_HATR.ASM
 Q_HBAR.OBJ: Q_HBAR.ASM
 Q_SCNKEY.OBJ: Q_SCNKEY.ASM
 Q_SETCUR.OBJ: Q_SETCUR.ASM
 Q_SETPRN.OBJ: Q_SETPRN.ASM
 Q_TCHIN.OBJ: Q_TCHIN.ASM
 Q_TEXT.OBJ: Q_TEXT.ASM
 Q_TEXTNA.OBJ: Q_TEXTNA.ASM
 Q_VATR.OBJ: Q_VATR.ASM
 Q_VBAR.OBJ: Q_VBAR.ASM
 XEXTMR.OBJ: XEXTMR.ASM
 XRINCOM.OBJ: XRINCOM.ASM
 XRNETLIB.OBJ: XRNETLIB.ASM
 XRPMODE.OBJ: XRPMODE.ASM
 XRPOUT.OBJ: XRPOUT.ASM

2.9.1.5 Executable:

MPIP.EXE: XECAT.OBJ\

ASOUND.OBJ
ASFLYBY.OBJ
CLRT.OBJ
D_FINI.OBJ
D_INIT.OBJ
DTINPUT.OBJ
DTPAGE.OBJ
DTUPDATE.OBJ
EIND.OBJ
F_INIT.OBJ
FYFLY.OBJ
LFUEL.OBJ
NRADALT.OBJ
Q_BATR.OBJ
Q_BOX.OBJ
Q_DINT.OBJ
Q_DREAL.OBJ
Q_HEX.OBJ
Q_HEX5.OBJ
Q_INT.OBJ
Q_REAL.OBJ
S_INIT.OBJ
SSWAP.OBJ
VBIRD.OBJ
VFORMAT.OBJ
W_INIT.OBJ
WMCANNON.OBJ
WMISSILE.OBJ
WMROCKET.OBJ
WMCHAFF.OBJ
WPASE.OBJ
XRACUOUT.OBJ
XRACUIN.OBJ
XRCHKSUM.OBJ
XREAINIT.OBJ
XRJOYINI.OBJ
XRINSOUT.OBJ
XRINSIN.OBJ
XRCPMOUT.OBJ
XRCPMIN.OBJ
XRNINIT.OBJ
XRNETIN.OBJ
XRNETWR.OBJ

XRSWAP.OBJ\
XRTIN.OBJ\
XRTOUT.OBJ\
XRTDIO.OBJ\
XRIOPACK.OBJ\
XRVISIN.OBJ\
XRVISOUT.OBJ\
XRBIT3I.OBJ\
XIDISEXT.OBJ\
XIDRALG2.OBJ\
XIDRALG3.OBJ\
XIDRALG4.OBJ\
XIDRENTB.OBJ\
XILDDEPDOBJ\
XILDESPD.OBJ\
XILDFIPD.OBJ\
XISTDEPD.OBJ\
XISTESPD.OBJ\
XISTFIPD.OBJ\
XISTEMPD.OBJ\
XIRCVCOL.OBJ\
XIRCVFRZ.OBJ\
XIRCVRES.OBJ\
XISWPDET.OBJ\
XISWPES.OBJ\
XISWPFIR.OBJ\
XISWPEMI.OBJ\
XISWPCOL.OBJ\
XISWPRES.OBJ\
XISWPFZR.OBJ\
XISWPACK.OBJ\
XIUDLENT.OBJ\
XIDRLENT.OBJ\
XIUPENTB.OBJ\
XIWRDEPD.OBJ\
XIWRESPD.OBJ\
XIWRFIPD.OBJ\
XIWRCPD.OBJ\
XIWRAKPD.OBJ\
XISWPER.OBJ\
XIWRERP.OBJ\
XIEVENTS.OBJ\
XIDISIN.OBJ\

XICLDIEN.OBJ
X_INIT.OBJ
XIDISTMR.OBJ
XICOLLID.OBJ
XINXTEVT.OBJ
XINXTENT.OBJ
XICONVRT.OBJ
Q_GETJOY.OBJ
Q_GETKEY.OBJ
Q_GETTCH.OBJ
Q_HATR.OBJ
Q_HBAR.OBJ
Q_SCNKEY.OBJ
Q_SETCUR.OBJ
Q_SETPRN.OBJ
Q_TCHIN.OBJ
Q_TEXT.OBJ
Q_TEXTNA.OBJ
Q_VATR.OBJ
Q_VBAR.OBJ
XEXTMR.OBJ
XRINCOM.OBJ
XRNETLIB.OBJ
XRPMODE.OBJ
XRPOUT.OBJ
DJDEBUG.OBJ
DJDPAG00.OBJ
DJDPAG01.OBJ
DJDPAG02.OBJ
DJDPAG03.OBJ
DJDPAG04.OBJ
DJDPAG05.OBJ
DJDPAG06.OBJ
DJDPAG07.OBJ
DJDPAG08.OBJ
DJDPAG09.OBJ
NAVINIT.OBJ
ZDCOMIN.OBJ
NWPTCTL.OBJ
NDOPLR58.OBJ
NDOPLR60.OBJ
ZMFDCTL.OBJ
KICTRL.OBJ

KVCTRL.OBJ
XRDCSOUT.OBJ
K_INIT.OBJ
MSN60_1.OBJ
MSN60_2.OBJ
MSN60_3.OBJ
MSN60_4.OBJ
MSN60_5.OBJ
MSN60_6.OBJ
MSN60_7.OBJ
MSN60_8.OBJ
MSN58_1.OBJ
MSN58_2.OBJ
MSN58_3.OBJ
MSN58_4.OBJ
MSN58_5.OBJ
MSN58_6.OBJ
MSN58_7.OBJ
MSN58_8.OBJ
MSN64_1.OBJ
MSN64_2.OBJ
MSN64_3.OBJ
MSN64_4.OBJ
MSN64_5.OBJ
MSN64_6.OBJ
MSN64_7.OBJ
MSN64_8.OBJ
SNEPC.OBJ
SNEPCR.OBJ
CINTBH.OBJ
LL2UTM.OBJ
UTM2LL.OBJ
NDIGITBH.OBJ
UMBUF.OBJ
DIGITBH.OBJ
WPAPR_39.OBJ
WMARM.OBJ
WMARM64.OBJ
WVTADS.OBJ
ZAHSYM.OBJ
WVMMS.OBJ
CSTUFF.OBJ
VBCMD.OBJ

VBORE.OBJ\
VBHEM.OBJ\
XRAI_RT.OBJ\
WMINIT.OBJ\
ZMFDSYM.OBJ\
LINK@UJBLD.DAT

Note: arms.exe is an identical copy of mpip.exe.

2.9.2 Instrument Display PCs

The four Instrument display PCs run Windows NT 3.51 operating system. In addition, the three main Instrument panel PCs have three executable programs, one for each aircraft configuration and the console PC has a single executable for all aircraft types. The following table details the executables and there locations.

	LEFT	CENTER	RIGHT	CONSOLE
OH58D	c:\58lft\oh_lft.exe	c:\58ctr\oh_ctr.exe	c:\58rht\oh_rht.exe	c:\con_ios\ios.exe
UH60	c:\60lft\bh_lft.exe	c:\60ctr\bh_ctr.exe	c:\60rht\bh_rht.exe	c:\con_ios\ios.exe
AH64	c:\64lft\ah_lft.exe	c:\64ctr\ah_ctr.exe	c:\64rht\ah_rht.exe	c:\con_ios\ios.exe

In addition, a batch file, *GO.BAT* is required to launch the executable with some command line options.

2.9.4 PDU Filter PC

The PDU Filter PC runs DOS as its operating system and a Reflectone product, *PDU Filter* to control the DIS traffic into and out of the local ARMS-TC intra-system network. The filter provides pass/no-pass decisions based on PDU type and range, and exercise and port number. A help screen (accessed by hitting ?) describes the keystrokes/instructions for varying the filter parameters. The executable resides in: c:\nfilter\ and is named *nf.exe*.

2.9.5 Aural Cue PC

The Aural Cue PC runs DOS as its operating system and a Reflectone product, Cue Sonic, to control the MIDI sampler that produces the aural cues for the ARMS-TC. The executable resides in: c:\msc\src\mpip\ and is named *cuesonic.exe*.

2.9.6 Control Loading PC

The control loading PC is part of a turn key electric control loading system from SAIC Inc. Please refer to supplied manuals for software configuration. Reflectone only modifies the four model configuration data files on this machine and there is no Reflectone specific code.

The executable is *cload.exe* and the system uses the DOS operating system.

2.9.7 Communications PC

The communications PC is part of a turn key DIS communications system from ASTI Inc. Please refer to supplied manuals for software configuration. Reflectone only modifies the model configuration data files on this machine and there is no Reflectone specific code.

The executable is *mb.exe* and the system uses the DOS operating system The configuration files are *arms_tc.mbl* and *arms_tc.cfg*.

2.9.8 SGI Infinite Reality

The Image generator is a multi-tasking graphics computer that is controlled by a menu program on the text console. The menu program and it's associated script files are:

STARTUP
OTW_GFX
HMD_GFX
AH64_HMD
OH58D_HMD
UH60_HMD
AH64_OTW
OH58D_OTW
UH60_OTW
VISUAL_SHUTDOWN

This scripts configure the graphics processor for the requested configuration and then launch the following programs:

<i>ENTMGR</i>	The DIS entity manager.
<i>CTTPACKET</i>	The IG to Host Communications manager
<i>DIS3D.OGL</i>	The visual system executable.

2.10 Software Restoration

An individual backup of each computer has been provided to aid in the restoration of a computer in the event of a hard disk or other failure. A procedure is provided for all the PCs in the system and for the Image Generator.

2.10.1 PCs (Except Control Loading)

Backups were made with a HP Colorado T1000e tape drive and this procedure assumes the same drive will be used to restore the software. Other systems may also read the tapes.

Turn off PC and tape drive (unplug).

If necessary, temporarily plug a standard monitor into the video connector on the PC (note that the high resolution monitors of the three main instrument displays will not operate in the text mode of the dos restore s/w and must also be temporarily replaced by a standard PC monitor).

Connect cable between drive and LPT1: parallel port on the PC.

Install the appropriate tape in drive door.

Install appropriate Back-up/Restore floppy disk in the floppy drive of the PC.

Turn on PC and let it boot from floppy.

Tape software will start automatically.

Select the Total Restore function.

2.10.2 Control Loading PC

Backups were made to a floppy disk set with the MSDOS (v6.22) Backup/Restore function.

Turn off PC.

Temporarily plug a standard monitor and keyboard into the PC.

Install DOS if necessary (insert DOS disk #1 (provided) and boot PC)

Type: *msbackup* <cr>

Let it auto-configure if necessary.

Insert first back-up disk into drive A:

Select the RESTORE option.

Insert disks as directed until the drive is completely restored.

2.10.3 Image Generator

The SGI Image generator is a complex graphics computer and a tape restore should only be attempted by qualified unix familiar personnel. The following is a general guideline for restoring the ARMS-TC. Note all ARMS-TC specific software is located on Disk 2 and that is what is stored on the tape.

Re-install SGI system software from original CDs to Disk 1.

ta -x the backup tape to Disk 2.

Run *syslink* utility on Disk 2 to update disk 1 configuration and to link the two disks.