

JPRS-EST-89-030
13 OCTOBER 1989



JPRS Report

Science & Technology

Europe

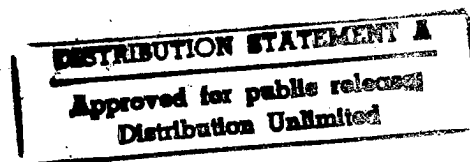

DTIC QUALITY INSPECTED 3

REPRODUCED BY
U.S. DEPARTMENT OF COMMERCE
NATIONAL TECHNICAL INFORMATION SERVICE
SPRINGFIELD, VA. 22161

19990106 075

Science & Technology Europe

JPRS-EST-89-030

CONTENTS

13 OCTOBER 1989

WEST EUROPE

ADVANCED MATERIALS

- FRG: BMFT Subsidizes Joint Projects for Ceramics Manufacturing
[Bonn TECHNOLOGIE NACHRICHTEN-MANAGEMENT INFORMATIONEN, 28 Jul 89] .. 1

AEROSPACE, CIVIL AVIATION

- European Space Station Conference Described [Rome AIR PRESS, 4 Jul 89] 1
SNECMA Concerns, Prospects Discussed
[Bernard Capillon interview; Paris L'ARMEMENT, May-Jun 89] 2
Current Budget, Operations of CNES Described [Toulouse LA LETTRE DU CNES, 13 Jun 89] .. 4
FRG: Dornier To Develop Columbus Resource Module
[Hermann Ricken; Friedrichshafen DORNIER POST, No 2, 89] 6
FRG: Dornier Heads ESA Ground Infrastructure Consortium
[Klaus Wessenberg, Michael Wlaka; Friedrichshafen DORNIER POST, No 2, 1989] 7
FRG: Dornier's Participation in Ariane 5 Described
[Horst Sauerwein, Egon Behle; Friedrichshafen DORNIER POST, No 2, 1989] 9
FRG: Future European Advanced Rocket Launcher Planned
[Wolfgang Westphal, Egon Behle; Friedrichshafen DORNIER POST, No 2, 1989] 11
Arianespace's 1989-1990 Launch Schedule Detailed [Rome AIR PRESS, 25 Jul 89] 15
Italy's BPD Develops Propulsion Subsystem [Rome AIR PRESS, 4 Jul 89] 16
Italian Company Develops Robotic Aid Prototype for Space Stations!
[Rome AIR PRESS, 25 Jul 89] 16
European Microgravity R&D Coordinated in Italy [Rome AIR PRESS, 12 Jul 89] 17

DEFENSE INDUSTRIES

- Belgium's Military Aviation Policy Criticized [Paul Louyet; Brussels INDUSTRIE, Jun 89] 17

FACTORY AUTOMATION, ROBOTICS

- Use of Robots in Belgian Industry Assessed [G. Denuit; Brussels INDUSTRIE, Jun 89] 17
FRG: Dornier's Catia Robot System Described
[Peter Putz, Werner Kortwinkel; Friedrichshafen DORNIER POST, No 2, 1989] 19
FIAT's FRG Subsidiary, Trumpf Group Develop Laser Robot
[Coburg OPTO ELEKTRONIK MAGAZIN, May 89] 19

SCIENCE & TECHNOLOGY POLICY

- Increased Research Budget Probable in 1990 [Philippe Escande; Paris LES ECHOS, 7 Jul 89] 19

SUPERCONDUCTIVITY

- Dutch TNO Upgrades MOCVD Technique [Rijswijk PT AKTUEEL, 5 Jul 89] 20

TECHNOLOGY TRANSFER

- Soviet Economist Comments on Computer Joint Ventures
[Roberto Frazzoli; Milan ITALIA OGGI, 20 Jul 89] 20

TELECOMMUNICATIONS R&D

Netherlands PTT To Invest in ISDN [Newbury <i>BENELUX ALERT</i> , 31 Aug 89]	21
Government Funds for High Definition TV Allocated [Paris <i>LE QUOTIDIEN DE PARIS</i> , 24 Aug 89]	21

EAST EUROPE

COMPUTERS

Bulgaria's Microclass Computer System Described [Aleksandur K. Aleksandrov, et al.; Sofia <i>ELEKTROPROMISHLENOST I PRIBOROSTROENE</i> , Jul 89]	23
RTV 2000: Basic Software for GDR's CAD/CAM Applications [Heinrich Haberland, et al.; <i>RECHENTECHNIK-DATENVERARBEITUNG in German</i> No 8, Aug 89]	25

MICROELECTRONICS

GDR Produces 32-bit Microprocessor [East Berlin <i>NEUES DEUTSCHLAND</i> , 15 Aug 89]	30
---	----

ADVANCED MATERIALS

FRG: BMFT Subsidizes Joint Projects for Ceramics Manufacturing

89MI0416 Bonn *TECHNOLOGIE NACHRICHTEN-MANAGEMENT INFORMATIONEN* in German
No 508, 28 Jul 89 p 11

[FRG Ministry for Research and Technology (BMFT) announcement of subsidies available for joint projects under the Manufacturing Technology Program, dated 20 July 1989]

[Text] The BMFT manufacturing technology program provides grants for joint projects seeking future-oriented solutions to problems facing a number of companies in important areas of manufacturing technology. To qualify, research and development projects must involve a particularly high development risk and large financial outlay and must be undertaken jointly by companies and research institutes. The Federal Ministry for Research and Technology is currently preparing a joint project, entitled Processing Methods for High Performance Ceramics (Hard Processing).

The increasing demands on new products require specific materials with special chemical, physical, and above all, mechanical properties. In this respect technical ceramics play an increasing role as materials for components subject to severe stress. Ceramic materials are mainly prized for their resistance to corrosion, temperature, and wear, together with their low weight.

Current practice increasingly demands ceramic components with high precision and material quality requirements. However, a breakthrough can be expected only if the properties of the materials are further improved and if economically viable manufacturing processes are available for finishing sintered ceramic parts. In fact, high surface quality and narrow tolerances at the ceramic materials' operational surfaces can still only be achieved by cutting.

Surfaces shaped by cutting exert a determining influence on the operational behavior of ceramic components.

Hard processing methods specially geared to small and medium production runs will be developed and improved.

The research and development work will:

- Cover processing methods, both new and already known, in ceramics production;
- Be process-oriented;
- Be carried out only with fully developed and perfected, commercially obtainable types of material (no material research).

The carbide (SiC, SiSiC), nitride (Si₃N₄), and oxide (Al₂O₂ZrO₂) groups are envisaged in particular.

The development targets are as follows:

- To clarify the mechanisms by which the particles of material are ground off during machining work, with a view toward optimizing and controlling the machining process;
- To answer questions of substantial importance for industrial practice, such as suitability of different cutting materials (i.e., CBN diamond); effect of the ceramic materials on cutting material wear; influence of the cooling lubrication; tribological aspects— influence of cooling lubricant additives and/or oils on processability; use of high cutting speeds to enhance cutting capacity and surface quality.
- Prototype development and application of the processing methods.

Additional information about this joint project may be obtained from: Manufacturing Technology Project Manager, Nuclear Research Center Karlsruhe GmbH, Box 36 40, 7500 Karlsruhe—Tel.: (07242) 82-52 92 (Mr Merker)

Producers and users of relevant products and processes as well as research institutes are invited to cooperate actively or informally.

Proposals for the implementation of this research and development project, initially in the form of rough drafts (topic, objective, work and time schedules, funding requirements, parties involved), should be submitted to the project manager by 1 September 1989.

Preferential consideration will be given to proposals that already contain concrete ideas on cooperation with companies and institutes (for example, the Fraunhofer Society and universities).

The grant of subsidies to commercial companies requires a minimum financial input of 50 percent by the company concerned.

Bonn, 20 June 1989; 424-7161-53-4/89; Signed by Dr Dreher for the Federal Minister of Research and Technology

AEROSPACE, CIVIL AVIATION

European Space Station Conference Described

89MI0409 Rome *AIR PRESS* in Italian 4 Jul 89 p 1369

[Text] The Fifth Columbus Symposium on the use of space stations opened in Naples on 3 July and then continued in Anacapri. The symposium was organized by the ESA [European Space Agency], the Ministry for Universities and Scientific Research, the FRG Ministry of Science and Technology, the Institute of Aerodynamics of the Umberto Nobile University of Naples, and MARS (Microgravity Advanced Research and User Support Center), with the support of ASI [Italian Space Agency], the Campania region, and Aeritalia (IRI [Institute for the Reconstruction of Industry]-Finmeccanica Group). This meeting is the third to be held in Italy (two previous symposiums were also held in Italy, and the remaining two in the FRG). The first day was devoted to

a review of the status of space stations and to the Columbus program, including its integration into the Freedom project. The third day centered on cooperation among scientific communities and the prospective uses of space stations.

The Anacapri symposium was attended by several experts including the undersecretary of research assigned to space research, Senator Learco Saporito, who chaired the meeting; Dr Mennicken of the FRG Ministry of Research; Mr Otao of NASDA (Japanese Space Agency); Bryan Erb of the Canadian Space Agency; and Mr Bartoe of NASA. Discussions primarily focused on activities related to the development of modular elements for Freedom's flight segment. The space station currently being designed by NASA is the main orbital element. The status of the flight segment's development for the Freedom project was explained by Mr Bartoe, who also outlined the time schedule for its implementation. Japan's JEM [Japanese Experimental Module] module was described by Mr Otao, who spoke of the time schedule for the development of the Japanese space station module, its constituent elements, the agencies and industries involved, and Japanese funding for the project. Engstrom from the ESA focused on the Columbus program in the framework of the Freedom space station. Engstrom maintained that the free-flying laboratory may prove to be a valid tool in developing experiments in space. He also emphasized the need to justify costs on the basis of the activities' returns, in view of the future commercialization of space. Another topic of major importance was technical support for the Columbus program. The first talk by Bryan Erb dealt with a service unit, capable of moving freely on the space station structure with mechanical arms for handling auxiliary and support equipment. This was followed by descriptions of the Data Relays Satellite as an element designed to transmit and receive data and images from the space station throughout its orbit, the European earth infrastructure designed to support Columbus, and the mission control station. Discussions also concentrated on decentralized support agencies. The first speech, given by J. Kehr of the DLR [German Aerospace Research Institute for Aeronautics and Astronautics], dealt with the activities of the laboratory control center. After the opening address by Prof Ernesto Vallerani, vice president of Aeritalia and director of Finmeccanica's Space Systems Group, Luciano Battocchio, from the same group, gave an account of the engineering support center for the European laboratory to be established in Turin. A similar topic was discussed by H. Kappler of MBB [Messerschmitt-Boelkow-Blohm]/ERNO, in connection with a support center for the Man-Tethered Free Flyer.

SNECMA Concerns, Prospects Discussed

*89AN0264 Paris L'ARMEMENT in French
May-Jun 89 pp 22-29*

[Interview with General Bernard Capillon, president and CEO of the National Company for Aircraft Engine Studies and Construction (SNECMA)]

[Excerpts] L'ARMEMENT: General, could you describe SNECMA to us? Capillon: SNECMA is both a company and a group, although usually the name refers only to the parent company.

This group is composed of: —SNECMA itself, with 13,500 employees and a turnover of Fr 10 billion, which manufactures military and civil aircraft engines; —The European Propulsion Company (SEP), which deals with propulsion systems for strategic and tactical missiles, both nuclear and conventional, and nonmilitary launch vehicles; —Messier-Hispano-Bugatti, which manufactures civil and military landing gear; —Hispano-Suiza, which works in the field of power transmission, thrust reversers, and automation; —SOCHATA-SNECMA, a specialist in repair and maintenance of our own engines as well as others; —Finally, Atlantic Mechanical Manufacturing (FAMAT)—which is not a subsidiary in the legal sense, since it is controlled jointly by SNECMA and GE—manufactures civil engine parts;

There are also some miscellaneous holdings.

In all, the SNECMA group has 26,000 employees and a turnover of Fr 17 billion.

Apart from the USSR, SNECMA is one of the four largest engine manufacturers in the world, the other three being General Electric, Pratt & Whitney, and Rolls-Royce. However, more important, among these four engine manufacturers only two are capable of constituting an industrial group in the civil and military aviation and space fields: SNECMA and Pratt & Whitney.

L'ARMEMENT: What is SNECMA's position in France?

Capillon: SNECMA's mission is twofold. Through its military programs, it must contribute to France's defense capabilities. However, through its civil programs it must also lend its support to the economic and social development of the whole of the domestic industry, in accordance with normal market forces.

In order to carry out these two tasks, it has developed a general strategy based on two complementary elements, in the best sense of the term: There is no conflicting overlapping or gray area between the two elements.

The first element consists in responding to defense requirements with its own resources, independently, which is perfectly logical given that military technology is far more demanding, in terms of performance, than the civil market.

The second element consists of a cooperation strategy, mainly for nonmilitary programs, which is carried out in two ways:

- Transatlantic cooperation, e.g., between SNECMA and GE; but also including the other members of the group, e.g., MHB with MENASCO, Hispano-Suiza with Rohr, etc.;

- European cooperation, which we are constantly seeking to strengthen so as to constitute, on this side of the Atlantic, another vital center for propulsion, mechanics, and equipment. This corresponds directly to our country's general policy, which—without attempting to dominate—seeks to ensure a significant French presence in Europe. The SEP is the best example of this, but this cooperation also involves the other companies in the group.

Subcontracting is an existing form of cooperation. However, joint development is increasingly sought, for example with the United States and with the FRG. Today, over and above specific programs, links are also forged through joint holding of part of companies' capital (not necessarily reciprocally).

At present we are the first French industrial exporter to the United States, our main customer being the U.S. Air Force. In terms of exports, French participation in CFM is greater than that in Airbus, which gives you an idea of our contribution to the export market.

L'ARMEMENT: How is this general strategy implemented?

Capillon: It is based on programs, both civil and military.

It should be remembered that the initial justification for the existence of SNECMA, its original activity, was the production of military engines. The nonmilitary sector developed alongside this, and came to account for a greater share of the turnover. At present the two sectors support each other, because the performance level required by the military sector reflects its technological excellence onto nonmilitary products, and the industrial and economic position that the civil market gives us makes our military R&D possible. This complementary relationship between the civil and military fields is a necessity that exists in the three other major engine manufacturers.

I should like to emphasize that the life cycle of an engine is about 50 years, and that we must be constantly at the forefront of technology; the most important elements for an engine manufacturer being materials, thermodynamics, aerodynamics (which involves much more than just designing wing profiles) and electronics (for digital regulation of engines). We allocate 25 percent of our turnover to R&D, 10 percent through contracts and 15 percent through self-funding.

The military programs include the ATAR series (Mirage III, IV, and F1), the LARZAC (Alpha Jet), the M53 (various versions of the Mirage 2000) and the M88.

The design of the M88, which will be used for the Rafale, represents a family of engines and is based on the design of the civil CFM-56. The thrust ratings of the various members of this family will range from 7 to more than 10.5 tons, the type chosen for the Rafale being the M88-2, which initially delivers 7.5 tons.

The advantage of the notion of a family, based on a single, high-pressure high-temperature core around which different low-pressure low-temperature elements can be used, is the possibility of making engines for different aircraft, notably in the context of cooperation.

This engine is now operational, and we are ahead with respect to performance, since it has already reached full throttle on the test bench, with afterburner. In addition, we are in line with budgetary forecasts. The next major steps will be the first flight on the current demonstrator, the Rafale A, in early 1990, and the first flight on the Rafale D fighter aircraft in early 1991. We are therefore well on target for operational service entry in 1996.

I shall turn to the civil programs after emphasizing that, out of the four major names worldwide, SNECMA is the last to have returned to the civil market after the Second World War.

Our work is also very much oriented toward the future. Right now we are carrying out research into systems designed to replace the Larzac, the M88, and the very large engines, as well as into variable-cycle engines which are likely to be used on the post-Concorde generation.

The SEP is the space arm of the group. Its activities cover thrust ratings ranging from 350 g (satellites) to 600 t (Ariane-5 boosters). Its military programs include the Mistral, the Super-530, the Hades, and the S4. In the civil area, there is, of course, the provision of propulsion systems for the whole series of Ariane launch vehicles, but there is also the Hermes shuttle, 60 percent of whose composite skin will come from SEP.

MHB deals with the undercarriage of all the French fighter aircraft, but also with that of the ATR-42 and Airbus aircraft. Of course, the other companies in the group contribute within their field to these various programs.

All in all, as you can see, we are a particularly well-positioned group, since, to repeat what I said earlier, we are an aviation and space "propulsion/mechanics" entity, both civil and military.

L'ARMEMENT: What are your current concerns?

Capillon: They center, of course, primarily on competitiveness, in the broadest sense of the term.

First of all, there is the technical and technological competitiveness that we have just discussed. Secondly, our prices must be sufficiently competitive. This aspect relies on productivity in all its forms, but also calls for the ability to manage matters pertaining to trade, compensation, technology transfer, etc., not forgetting after-sale service, which sometimes makes all the difference and, in any event, helps ensure customer loyalty.

L'ARMEMENT: How do you view the move toward the single European market?

Capillon: My opinion is above all that events will unfold progressively, far less abruptly than is generally anticipated.

Aspects will emerge which one will have to learn to manage: monetary and customs questions, greater mobility of people, research and production centers, and deregulation of air traffic—the latter point being of prime concern to us.

Like all firms, the SNECMA group will be affected by these developments, but we await them with confidence, since we already have considerable experience in European and worldwide cooperation.

In this wider context we intend to increase our standing as a group in order to constitute, as I indicated earlier, a focal point for aviation and space propulsion and mechanics, both military and civil, at the domestic level and in all our collaborative efforts.

Current Budget, Operations of CNES Described

89AN0287 Toulouse LA LETTRE DU CNES in French
13 Jun 89 pp 2-5

[Text] The decisions made by the European ministers at The Hague in November 1987 affect the CNES budget and program for 1989. The French Government wants to maintain the advantageous position attained in the marketing of launching services in an increasingly competitive environment. It wishes to launch a new space policy whose goal is to establish European autonomy in the important area of manned flights and orbital infrastructure within the next 10 years. At the same time as these major projects are implemented, the desire to preserve accomplishments and to complete what has been begun have resulted in a decision to:

- Extend the service offered by the Spot system by launching Spot-2, develop Spot-3, and study the development of Spot-4 (decision to be made this year);
- Continue efforts in the area of European telecommunications programs that will eventually produce the tools indispensable for the support of manned flights;
- Ensure regular progress in European scientific research programs and collaborate with the major space powers to guarantee the French scientific community a leading position on the international level;
- Replace assistance given to French users of space (France Telecom, Telediffusion de France, Directions des Engins);
- Continue essential activities in the framework of research and technology projects and preparation of future programs.

CNES 1989 Budget	
Headings	Initial 1989 Budget, Incl Taxes
State subsidy:	6,453.011

CNES 1989 Budget (Continued)

Headings	Initial 1989 Budget, Incl Taxes
—Program authorization (Ministry of Post, Telecommunications & Space (PTE)—chapter 83.59)	5,747.000
—Ordinary expenditures (Ministry of Research & Technology (MRT)—chapter 36.80)	706.011
Own funds	1,630.200
Total	8,083.211

Amounts expressed in million francs

The table above shows a breakdown of the CNES 1989 budget, including all taxes, according to funding source.

After deduction of the VAT that CNES pays on operating subsidies received from the government, the actual funds available to CNES to cover the operations described in the 1989 budget amount to a total of Fr 7,794.488 million, as compared with Fr 6,331.228 million in the initial 1988 budget, or a 23.1-percent increase.

The CNES budget (subsidies and own funds) is subdivided into five major areas:

- European multilateral cooperation,
- bilateral cooperation,
- national program,
- technical operational support of programs,
- general operations.

The graphs below show the development of these five areas between 1988 and 1989 (in millions of francs). An increase of 22.4 percent in the 1989 budget, as compared with 1988, is evident.

European Multilateral Cooperation

The funds allocated under this heading cover France's contribution to the various programs of the European Space Agency (ESA): Fr 3,281 million have been earmarked for 1989.

The scientific programs (7.9 percent) include:

- Operational satellites, including Exosat (European X-Ray Observatory Satellite) and IUE (International Ultraviolet Explorer);
- Projects under development, including the Space Telescope, Ulysses (formerly the international solar polar mission), Hipparcos (astronomical satellite), ISO (infrared astronomy), SOHO (solar observatory), and Cluster (study of the magnetosphere);
- Future projects, including the XMM project (x-ray spectroscopy), a mission for recovering comet core samples, a submillimeter astronomy mission, and the Saturn observation project (Cassini).

In the field of communications satellites (1.7 percent), the following should be noted:

- The ECS point-to-point telecommunications satellites;

1988

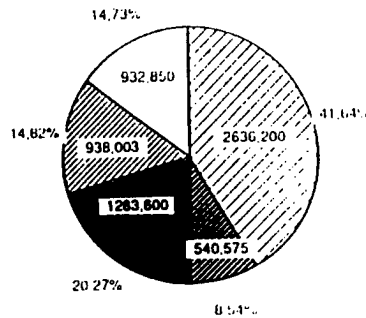

1989

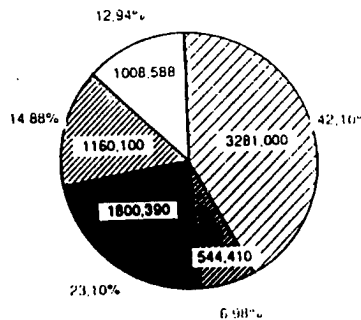

- European multilateral cooperation
- bilateral cooperation
- national program
- technical operating support of programs
- general operations

- The maritime telecommunications satellites, including Prosat, and the IOC/Eureca and DRPP/PSDE (data relay satellite system) interorbital telecommunications satellites,
- Feasibility studies (ASTP) for future ESA telecommunications programs.

In the area of earth observation (7.9 percent), the following programs should be cited: the Lasso-P2 (clock synchronization by laser), ERS-1 (ocean observation), and EOPP (research in future technologies).

Programs in the spacecraft area (7.4 percent) include the Spacelab space laboratory in conjunction with studies of the Eureca retrievable space platform, microgravity research, and development of the Columbus space station.

In the area of launch vehicles (69.9 percent), France, as an ESA member-state, helps finance the space center in Guiana.

The lion's share of this budget, however, goes to the Ariane program. The Ariane-5 launcher, which will be operational in 1995, will make it possible to place a mass of 6,800 kg into geostationary orbit and to launch the Hermes spacecraft. This program also aims to improve the Ariane launcher. The Hermes spacecraft is essential to European autonomy in manned flights. The Hermes missions seek to service the Columbus laboratory, the

Freedom international space station, and the European APM module, as well as unmanned flights for micro-gravity applications.

Joint expenditures represent 5.2 percent of the funding for European multilateral collaboration.

Bilateral Cooperation

Cooperation with NASA (58 percent) comprises:

- Scientific experiments, mainly with Topex-Poseidon (space oceanography), Windii-UARS (wind and temperature measurements), LASE (study of the lower atmosphere), and Ulysses/Galileo (exploration of Jupiter).
- Earth observation, for earth resources exploitation (experiments based on data received from the U.S. Landsat, NOAA, and Seasat satellites) on the one hand, and, on the other, in meteorology for data collection or position tracking (Argos and Sargos systems). The Soviet Union participates in this program through its Cospas system, which is compatible with the French-U.S.-Canadian Sarsat program, designed to quickly detect planes and ships in distress that are equipped with an inexpensive space transmitter.

An intergovernmental agreement ensuring the continuity of the system was signed in Paris on 1 July 1988 by representatives of the four participating countries. CNES is developing new instruments to ensure continuity of the Argos-Sargos service until 1995.

- Manned flights, including experiments in the field of physical sciences (Mephisto) or life sciences, such as Rhesus (animal experiments) and Ace of Hearts (cardiovascular adjustment).

Collaboration with the USSR (12.7 percent) involves numerous scientific experiments including the Sigma, Gamma-1, and Phebus telescopes; the Phobos project for low flights over Mars and its Phobos satellite; the Interball experiments to study the relationships among solar wind, magnetosphere, and ionosphere; the Scarabee project (study of the earth's radiation balance); the Alissa project (utilization of LIDARs from space); and French experiments for the major Soviet mission to Mars in 1994. After the manned flight from 26 November to 21 December 1988 in which the French astronaut Jean-Loup Chretien took part, an agreement in principle was signed with the Soviets for the implementation of a long-term program (conducting French experiments and tests on the Soviet Mir space station).

Collaboration with ESA (12.7 percent) focuses on scientific experiments still under development. We can cite the Spectro ISO interferometer, the Camisole two-channel infrared camera, the "First" instrument for submillimeter astronomy, and the ATSR-M radiometer on board the ERS satellite (launch in 1990). Finally, the SOHO satellite will study the sun (launch in 1995), and the Cluster experiments will explore the magnetosphere.

In the Silex program, CNES also cooperates with ESA in the field of telecommunications, setting up experimental links between two satellites. The Spacelab-D2 missions (West German flight in 1991) and Eureca (first flight scheduled for 1991) are preparing for manned flights.

Collaboration with the FRG (10.6 percent) continues in the scientific field with the ERIC VLBI program for moving object tracking. However, collaboration with the FRG is essentially done at the telecommunications level with the TVSAT (German) and TDF (French) direct television satellite programs. The French TDF-1 satellite was successfully launched in October 1988. Launch of TDF-2 is expected in February 1990. The FRG is to place its TVSAT-2 satellite into orbit in July 1989.

The CNES also cooperates with various countries (6 percent), such as Sweden in the Viking and Tele-X programs, and is involved in bilateral export-oriented projects (training, marketing of Spot and Ariane, engineering, etc.). CNES conducts public relations campaigns aimed at major international organizations in order to promote the image of the French space industry.

National Program The operations planned as part of the national program are intended to promote future technologies and systems and to implement projects that are a top priority for France.

Scientific experiments for 1989 include balloon (Pronaos submillimeter telescope) and geodetic experiments.

In the field of telecommunications, CNES and France Telecom have concluded an agreement for the establishment of a Telecom-2 satellite management team to ensure continuity of the national telecommunications system beyond Telecom-1.

The earth observation experiments (79 percent) scheduled for 1989 involve the use of data from the Spot and ERS-1 remote sensing satellites.

Given that the Spot-1 launched in February 1986 is still performing well, Spot-2 will not be launched until late 1989. Income from sales of images cover an increasingly greater proportion of expenses. Spot-3 will be ready for launch in 1990, and the government is considering a proposal for development of Spot-4.

Let us recall that CNES is responsible for the overall architecture and the space component of the Helios military system.

Balloons are an addition required by aeronomy and meteorology observation programs at altitudes between 15,000 and 45,000 meters. More than 50 flights have been carried out in France and abroad, carrying increasingly heavier loads and lasting increasingly longer.

In the field of space transport systems, CNES is participating in the development of the Ariane and Hermes lines at the national level simultaneously with European activities.

The research and technology program (15.9 percent) for 1989 emphasizes improved competitiveness in radio-communications, earth observation and scientific instrumentation, continued efforts in priority areas, fields as well as the acquisition of basic techniques relevant to future launch vehicles.

Finally, funds have been earmarked for improving the quality and reliability of future space vessels.

Technical Operating Support of Programs

Funding amounts to Fr 2,168.688 million in 1989, as compared with Fr 1,870.853 million in 1988. It is destined for funding the development of "heavy equipment," such as networks of control stations, computer facilities, and metropolitan testing facilities (Fr 227.500 million) as well as facilities at the Guiana Space Center (Fr 551.900 million). Funding for scientific laboratories (Fr 42.150 million), work on infrastructure and equipment (Fr 207.150 million), and miscellaneous funding (Fr 131.400 million) (participation in Arianespace's capital) are also included in this total.

General Operations

General operations of the CNES departments (personnel and operating expenses, public relations, travel) amount to Fr 1,008.588 million. Total CNES personnel figures will reach 2,357 by the end of 1989, according to the following expected breakdown:

Paris headquarters:	201
Evry space center	243
Guiana space center	326
Toulouse space center	1,587

FRG: Dornier To Develop Columbus Resource Module

36980271 Friedrichshafen DORNIER POST in English
No 2/89 pp 98-99

[Article by Hermann Ricken: "Resource Module—Dornier's Contribution to the Columbus Free Flying Laboratory"]

[Text] The Columbus Resource Module (RM) which, together with the two segment Pressurized Module (PM), forms the Columbus Free Flying Laboratory, formerly named Man-Tended Free Flyer (MTTF), [as published] will be developed by Dornier as Element Contractor within the industrial Columbus consortium headed by MBB/ERNO and under ESA responsibility. The Resource Module has to ensure all key functions to permit autonomous work and manoeuvrability of the Free Flying Laboratory in support of life/material science and fluid physics. The Resource Module provides all necessary resources for this operation.

The main design key parameters of the Resource Module are as follows:

The Free Flying Laboratory will be launched by Ariane 5 into Space Station "Freedom" co-orbit, Resource Module on top of the Pressurized Module. The attitude is sunfixed with a 28.5 degree inclination co-orbit to the Space Station, free drifting without disturbances during operation for low microgravity (boomerang orbit). Under specific conditions the RM generated disturbances will not exceed 1 µg at the PM/RM interface. The orbit transfer and the rendezvous are executed by bipropellant thrusters, final approach to berthing distance is done by cold gas, berthing by Space Station robotics to its docking port.

The RM complies to a lifetime requirement of 30 years either by ORU exchange or by design. Orbital Replacement Unit (ORU) exchange of small non-hazardous ORU's and ECLS gas resupply via pressure line can be done by Hermes. Full Resource Module servicing can be performed at the Space Station Freedom by ORU replacement with manipulator system and partially by EVA. ECLS gas resupply is planned from Space Station via pressure lines or by Super ORU exchange. The ECLS gas consumables are replenished at each service cycle (180 days) at Space Station/Hermes by repressurization of gas tanks. Bi-propellant, cold gas, batteries and fluid pumps are to be exchanged after 3 years at the Space Station by Super ORU replacement. Solar arrays have to be exchanged after 9 years at the Space Station. Failed ORU's will be exchanged at Hermes or Space Station. For the PM-ECLS the RM supplies N₂ + O₂ for leakage compensation. Repressurization (after emergency pressure release) is done at Space Station or Hermes. For life science payloads further consumables may be provided by Resource Module Super ORU upgrading.

Contingency Rendezvous and Docking (RVD) capabilities are provided after two failures of the Free Flying Laboratory in any relevant functional chain. Additional failures will lead to safe abort of Space Station RVD.

The Pressurized Module is connected to RM by EVA-separable structure and utility interface (contingency separation only).

Radiation, thermal and micrometeoroid protection is provided by primary structure and structure covers. Reduced protection is tolerable during ORU replacement due to short time exposure.

The Resource Module provides 19.0 kW (EOL) solar array power i.e. 2.0 kW to RM S/S, 6 kW to PM incl. 4 kW for P/L at 120 VDC.

RM generated heat (4.0 kW) is rejected by passive radiators and loop connected radiators on the RM surface. Heat transport and heat sharing with PM is supported by a freon loop. The RM is passively controlled after two failures of the active cooling loop.

The Free Flying Laboratory performs the following communication:

Composite data	100 Mbps via EDRS
Formatted system data	2.5 Mbps via EDRS
HL-TTC forward*	1 Kbps via S-Band
HL-TTC return*	1 Kbps via S-Band
HL-TTC forward (Freedom/HMS)	10 Kbps via Ku-Band
HL-TTC return (Freedom/HMS)	10 Kbps via Ku-Band

*direct to ground and via DRS (both spread spectrum)

The present schedule results in a RM delivery to MBB/ERNO in October 1996 as such to meet the planned Free Flying Laboratory launch date of 1 April 1998.

FRG: Dornier Heads ESA Ground Infrastructure Consortium

36980270 *Friedrichshafen DORNIER POST in English No 2, 1989 pp 110-113*

[Article by Klaus Wessenberg, Michael Wlaka: "Ground Infrastructure for European Manned Space Travel"]

[Excerpt] [Passage omitted]

Relationship Between Space and Ground Elements

The large-scale European space programs Ariane 5, Columbus, Data Relay Satellite (DRS), and Hermes, all presently in development, consist of the following elements:

- European space laboratory (Columbus Attached Laboratory, formerly Attached Pressurized Module - APM), which will be docked to the international space station Freedom. Launch will be made with the Space Shuttle (planned for 1996).
- Polar Platform (PPF), for exploration in polar orbit, will be launched with Ariane 5 (planned for 1997).
- Columbus Free Flyer Laboratory, formerly Manned Free Flyer (MTFF), in a similar orbit as the United States Space Station, will be launched with Ariane 5 (planned for 1998). Until the availability of Hermes, functions will be carried out completely on the international space station. Hermes will perform internal maintenance every 180 days; external maintenance will be performed every four years from the space station. Limited external maintenance is also possible and scheduled with Hermes (with Extra Vehicular Activity - EVA).
- Hermes transport system, with operational applications by 1999, will be launched with Ariane 5.
- Communications Satellite Data Relay Satellite (DRS) will serve as part of the communications network.
- Ariane 5 carrier rocket will serve as heart of the transport system.

In contrast to earlier space travel programs, which generally were individual projects, the above-mentioned programs represent portions of a manifold, cohesive total system. This complete system requires a comprehensive, newly established ground infrastructure.

Ground infrastructure means the total of all facilities, equipment, and services required for constructing and, especially, for later operating space elements.

The decades-long operations phase of the space elements represents an entirely new dimension, in terms of technical and organizational aspects, as well as operational costs. According to present estimates, annual operating costs will exceed the total costs of a conventional satellite program. Because operating costs greatly depend on conception and quality of the infrastructure, intensive work is being done now to plan the entire concept and the individual elements.

Total Concept of the Ground Infrastructure

Europe's basic ground-infrastructure concept is influenced primarily by the ESA Advisory Council's decision to follow a decentralized solution. In establishing the geographic allocations of the main centers, function tasks for mission/flight control, technical support, astronaut training, and user requirement have been divided correspondingly.

For conducting these tasks, there will be several mission and training center in Europe:

- Central Mission Control Center (CMCC) with the Communication Resource Management Center (CRMC) and the Central Navigation System Facility (CNSF) at ESOC in Darmstadt.
- Manned Space Laboratory Control Center (MSCC) in Germany.
- Technical support facilities in Germany and Italy for the Columbus Free Flyer and Columbus Attached Laboratory, which will be permanently connected to the international space station Freedom.
- Facilities for operating and using the Columbus Polar Platform.
- Hermes Flight Control Center (HFCC) and Hermes Engineering Support Center in France.
- Launch and landing facilities in French Guiana.
- Operation and mission centers and in-orbit test stations for the European Data Relay Satellite (DRS) in Belgium, Italy, and Spain.
- Astronaut headquarters and related training facilities in Belgium, France, Germany, and Holland.
- Integration, test, and simulation facilities for testing and qualifying equipment, systems, and software.

—User-centers for preparing and evaluating experiments.

Such a decentralized structure requires a headquarters that coordinates the interplay of the elements. This responsibility will be handled by the Central Mission Control Center (CMCC), which will be established at the European Space Operations Center (ESOC) in Darmstadt. The CMCC has central responsibility for operating the space elements. Actual performance of operational tasks during normal space element operations will be handled by the element-specific control centers, such as manned Space Laboratories Control Center, Hermes Flight Control Center, DRS Operations Control Center, Polar Platform Control Center, and launch/landing facilities in Kourou.

In operating the space elements, numerous communications connections are necessary: commands must be discharged, operations data examined, users given access to the results of their experiments, and commands for new arrangements transmitted. This requires central management of communications connections, both to space segments and on the ground. For this purpose, a Communication Resource Management Center (CRMC) will be established as a further functional unit for the CMCC. In addition, a Central Navigation Support function will be established for the space elements.

Proposed communications network architecture consists of a broadband connection between the three main centers in Darmstadt, Oberpfaffenhofen, and Toulouse. Remaining ground centers will be connected in star formations to these main centers.

A role similar to CMCC (in the area of missions operation) will be performed by the European Astronaut Headquarters (EAHQ) for astronaut training tasks. EAHQ will be constructed as a new ESA facility on DLR's property in Porz-Wahn. It will be the home base for all future ESA astronauts. EAHQ's most important activities will be selecting the astronauts, determining a training program, and coordinating the decentralized training facilities.

At the same location in Porz-Wahn, a Crew Training Complex (CTC) will be constructed. The basic training for all ESA astronauts, as well as essential parts of the specialized and mission training, will be conducted there. In addition to CTC, further training facilities for special tasks (such as pilot training and training for maintenance work outside the space elements) are planned for other places in Europe. On the user side, only individual functions and their manifestations have been defined so far in various centers. These include the User Support Operation Coordination Center (USOC), User Familiarization Center (UFC), and User Home Base (UHB).

Dornier Focal Points

Participants in German space research have announced their goal in playing a decisive role in future European programs for manned space travel. German interests in ground infrastructure are concentrated in the Central Mission Control Center (CMCC) facility in Darmstadt,

Manned Space Laboratories Control Center (MSCC) in Oberpfaffenhofen, Astronaut Headquarters and Crew Training Complex (CTC) in Porz-Wahn, and user facilities. Dornier's interests, which coincide with these activities, are concentrated on the two centers MSCC and CTC.

MSCC primarily fulfills the following tasks:

- Supervising and controlling MTFE in all mission phases.
- Controlling and coordinating MTFE payloads.
- Controlling and coordinating the entire European payload in APM and in the rest of the international space station, including the supervision of APM's payload-related system functions.

In order to fulfill these tasks, MSCC will be equipped with a wide range of systems (hardware and software) for communications, data processing and storage, mission planning, mission supervision, and mission evaluation. For purposes of coordinating MSCC's operating functions as well as for training ground personnel, this equipment will be enhanced with comprehensive simulation facilities - so-called Operations Mission Sequence Simulators (OMSS).

The CTC, which will be constructed as DLR facility near the astronaut headquarters in Porz-Wahn, primarily will assume the following training activities:

- Basic training - becoming familiar with the space environment and gaining fundamental knowledge of APM, MTFE, and Hermes space elements.
- Special training - becoming familiar with APM's and MTFE's individual subsystems and performing service tasks. APM training is closely coordinated with NASA activities.
- Mission training - training in payload operations and maintenance for a specific mission as well as special system tasks for APM and MTFE.

In order to accomplish these tasks, various facilities are needed. These include training models of all space elements and their parts, water tank for simulating weightlessness, extensive data processing and communications facilities, training rooms, and facilities for computer-supported training in theoretical instruction. Furthermore, extensive facilities are needed for medical services and for maintaining body fitness.

Along with the MSCC and CTC centers, for which Dornier aspires to obtain industrial leadership in the definition and construction phases, the company will cooperate as an authority in defining and constructing other centers, such as the Central Mission Control Center, Hermes Flight Control Center, and support centers.

Outlook

In mid-1989, definition phases for the most important ground centers will begin. ESA will award various contracts to industrial consortia so that the individual centers' functions and systems parts will be defined in detail and specifications for succeeding construction will be established by the end of 1990. Due to its many years of preparatory work, Dornier has been appointed by ESA as industrial leader for defining MSCC. For this purpose, the company currently is building up a team of several German and European firms.

Because of its many preparatory studies in the area of astronaut training as well as through its leading role in developing the European space suit, Dornier also is qualified as the leading industry company for defining and constructing the CTC. In this role, Dornier is supported by BMFT and DLR. Inasmuch as ESA's preparations for the Crews Training Center are not yet as advanced as for the other ground centers, it is expected that ESA contracts will be conferred later. Despite this, Dornier already is putting together an industrial team for this purpose.

In addition to short- and medium-term planning for defining and constructing the centers, Dornier already is investigating future operational phases. The focal point of these considerations is the question how far is it possible for one or more private companies to handle space element and related ground infrastructure operations.

Through many years of preparation, both in the form of studies and development/construction of ground facilities for satellite control centers, Dornier has created a good starting position for forthcoming tasks in constructing and operating the future European ground infrastructure.

FRG: Dornier's Participation in Ariane 5 Described

36980273 *Friedrichshafen DORNIER POST in English*
No 2, 1989 pp 128-132

[Article by Horst Sauerwein, Egon Behle: "Ariane 5 - Europe's Next-Generation Space Transportation System"]

[Text] With Ariane 5, Europe will have available by 1995 a space transportation system that will transport satellites into low-earth orbit and geostationary orbit. It also will be the first carrier, together with the space glider Hermes, to open the door to European manned space travel. While Ariane 2 to 4 were developed as incremental-scale enlargements or with the addition of booster and engine components from the preceding Ariane version, Ariane 5 will use new concepts and technologies to meet increased performance requirements. Dornier participates in developing important components, which will be produced in the future.

Ariane 5 in Future International Competition

The Ariane 5 development program began in summer 1988. It received its impetus at the ESA ministerial conference in The Hague, The Netherlands, in November 1987. According to the ESA's long-term plan, Ariane 5 will make its first flight in 1995. Three years later, manned flight with Hermes is planned.

A series of market analyses for payload requirements shortly before the turn of the century shows that the number of 2- to 2.8-ton satellites in geostationary orbit will increase significantly and, in the middle of the 1990s, will constitute approximately 50 percent of the total commercial payload market. Of that amount, around 20 percent will be telecommunications satellites and around 25 percent earth-observation and scientific satellites. Arianespace, the operating company for Ariane carrier rockets in which Dornier also holds a share, currently transports about 60 percent of the Western world's payloads into space.

To maintain a corresponding market share in the future, Europe needs a higher performance carrier rocket that can take two 3-ton satellites into geostationary transfer orbit.

At the beginning of the 1990s, America's Titan III and IV will enter the market as main competitors. The Space Shuttle disaster in 1986 has given traditional non-reusable carrier rockets a new justification in the United States. At the same time, the Japanese H II will strive to contest Ariane 5 market shares. Based on their payload capacity, China's Long March and the Soviet Union's Proton carriers also can be considered as competitors. However, their share in transporting Western payloads will be influenced by many political conditions, which are difficult to estimate.

Technical System Overview

Ariane 5 is distinguished from its predecessors in several main areas determined by advances in the rocket technology sector during the past few years. The most remarkable difference in the configuration, compared to Ariane 1, is that Ariane 5 has tandem stages, with no real second- let alone third-rocket stage. The combination of a high-energy central stage with relatively low-energy solid-fuel boosters makes it possible to forego a large third stage, as well as avoid using expensive and complex liquid-fuel engines to accomplish the relatively high lift-off boost required.

A small, additional L7 kick stage in the automatic version of Ariane 5 places the payload(s) into the desired orbit. For this purpose, the stage can be ignited several times by remote control. Payloads are carried and protected by Speltra; its fairing provides aerodynamic protection during lift-off. The central stage consists essentially of tanks for the high-energy hydrogen/oxygen fuel combination, booster structure, cabling, and rocket engine. Because fuel only can be carried along in fluid

form at low temperatures, special technological requirements are placed on the H150 stage system. Most of the thrust, about 1,200 tons, comes from two P230 solid-fuel boosters. A new development in the Ariane program is the booster's swivel-mounted jet system.

Overview of European industrial companies participating as stage 1 subcontractors on Ariane 5 development:

Ariane 5 Components	Company	Country
Solid-Fuel Booster (housing)	Aerospatiale	France
Central Stage	Aerospatiale	France
Fairing	Contraves	Switzerland
Speltra	Dornier	Germany
Solid-Fuel Booster (rocket engine)	Europropulsion	France, Italy
Guidance and Control Unit	Matra	France
Kick Stage	MBB/Erno	Germany
Liquid-Fuel Rocket Engine	SEP	France

Responsible for the development of the entire system is Aerospatiale, which serves as industrial architect. Besides the companies listed, there are many more European companies involved as subcontractors. For example, in addition to developing Speltra, Dornier is developing the hydrogen/oxygen-propellant tanks under subcontract to an Aerospatiale subsidiary, which is responsible for the tanks central stage.

Dornier Projects for Developing the Ariane 5 Carrier

At present, Dornier, is working on two projects for developing the Ariane 5 carrier: the fairing and the payload carrier structure as well as the propellant tanks for the H150 cryogenic central stage. Both projects run about five years and each will cost about DM 70 million. Contract negotiations are nearly completed. Further offers for participating in the development of on-board computer software and tanks for the satellite kick-stage L7 have been submitted, and are awaiting decision.

Speltra

The modular payload carrier and fairing system Speltra (Structure Porteuse Externe Lancement Triple pour Ariane) must fulfill extreme requirements for minimizing weight, because each kilogram in volume saved can increase the payload by the same amount. Therefore, panel construction using carbon-fiber reinforced plastic plates combined with aluminum sandwiches was chosen. These panels are connected with rings made from a suitable aluminum alloy. One of these rings contains a pyrotechnical separation system, which will be developed by a French subcontractor still to be selected. An eight-spring system in the separation stage disconnects the payload and carrier and/or payload and payload following activation of the separation system. Speltra also has electric interfaces to payload and carrier, because the cabling leads through them. With a length of seven meters and a diameter of 5.4 meters, the longest

version of the fully equipped Speltra weighs 920 kilograms. It should be noted that it encompasses a usable volume of more than 70 cubic meters. Because a short version of Speltra is being developed, a modular system is possible that can transport various sized payloads simultaneously. Panel production is handled by Dornier Luftfahrt GmbH in Munich. The Hoesch company in Dortmund, as subcontractor, is producing the rings. A considerable amount of the project costs cover development and construction of the assembly tools and integration scaffolding, for which the company Stahler near Siegen is the contractor.

Propellant Tanks

The hydrogen/oxygen tank for the cryogen central stage consists of a cylindrical part and three tank sections. The middle section serves as the only dividing wall between the liquid hydrogen and the liquid oxygen. Due to tank dimensions specified, construction of its dome requires welding several segments together, because the raw metal is not available on the market in the total size needed. New technologies resulting from this project include the use of aluminum alloy 2219, still relatively unknown in Europe, which can be seen as "the" future aerospace material due to its special characteristics.

Shaping the dome segments also uses a relatively new procedure: steel-ball firing formation, which has not been used before in Europe for such large components with such a shape. The dome is mechanically shaped by a process of bombarding the metal with steel balls. Necessary parameters, such as ball diameter, ball impact velocity, and procedures were ascertained in a virtually completed feasibility study. A contract has been awarded for the steel-ball firing machine with automatic process control needed for the development program.

The machine developed for welding individual parts into a tank section can be considered a special production asset. After the welding seams are prepared mechanically, all necessary weldings are carried out by automatic control. Contract for the entire production of the propellant tanks has been awarded to Dornier Luftfahrt GmbH.

Outlook

For industrial companies, the production of non-reusable carrier rockets represents mass production with continuous operation and corresponding jobs. The recently signed contract between Ariane-space and the European industry for 50 Ariane 4 carriers rockets underlines this situation. By the mid 1990s, mass production of Ariane 5 also will begin with annual requirements of eight to 10 carriers.

Maintaining these high production standards for space vehicles under mass-production situations, represents a challenge for all participating industrial companies. With Ariane 5, due to its use for manned space flights, even higher quality requirements will need to be met. Dornier will participate in this challenge by producing propellant tanks and the Speltra.

Having already completed successful structure and tank production for Ariane 1 to 4 and being in the leading position in the area of super-light and highly rigid bonded materials (carbon-fiber reinforced plastics), Dornier is in an excellent position to expand its activities. This is one reason that Dornier, in the face of strong international competition on the American market, was able to win the contract for developing and producing the satellite load structure for the Titan III carrier rocket.

With this background and based on corresponding market analyses, Dornier has outstanding chances to receive further contracts worldwide. For carrier systems following Ariane 5, such as Earl, Sanger, and other concepts, Dornier will strive to build on experiences achieved as it continues to ensure participation in development and production projects within the restructured German aerospace industry.

FRG: Future European Advanced Rocket Launcher Planned

36980272 *Friedrichshafen DORNIER POST in English*
No 2, 1989 pp 123-127

[Article by Wolfgang Westphal, Egon Behle: "EARL—Concept Suggestion for a European Space Transport System After Ariane 5 and Hermes"]

[Text] EARL (European Advanced Rocket Launcher) is a manned, vertical take-off and horizontal landing, two-stage space transport system. The concept has been investigated by Dornier under contract by BMFT since 1986. Since 1988, this concept study has been continued under the name EARL II with the company MAN Technologies as partner and in cooperation with MBB. Until 1990, the concept alternatives tandem and parallel stages will be considered in depth. The goal of this work is to achieve in Germany the basis for having a say in defining a possible European rocket-driven space transport system after Ariane 5 and Hermes. EARL has, in the meantime, been accepted by BMFT as a reference concept for the study group New Space Transport Systems (NRT).

Programmatic Conditions

Between 1982 and 1985, under contract by ESA, space transport concepts were examined as successors to Ariane 4/5. This study (Future Launcher System - FLS) was conducted by Aerospatiale in France. Dornier was responsible for processing the essential aspects of system analysis and planning, as well as identifying technology requirements. In 1985, this study project was suspended on the ESA level. Building on experiences gained from the FLS study, the EARL family came into being under contract by BMFT. The EARL family consists of a re-usable, winged first stage and two different upper stages matched to mission demands - one winged and re-usable for manned transport, and one disposable for transporting large payloads.

A European carrier system after Ariane 5 and Hermes must mean a limited technological step ahead in order to be financially justifiable within the framework of the available European budget. EARL takes this step with the re-usability of the basic system and complete use of high-energy propulsion with liquid hydrogen (LH2) and liquid oxygen (LOX). The infrastructure of the present launch facilities in Kourou can be adopted almost entirely.

The concept has good chances of finding broad European acceptance, because it clearly is oriented to the presently supposed European transport needs for the year 2005 and beyond. In continuing investigations through the EARL II study, in which MAN Technologie particularly contributed the idea of a parallel-stage arrangement, fundamental system questions and in-depth aspects on the component level will be analyzed, so that all participants will be able to come to a mutually agreeable concept proposal. This can then be discussed with other European partners in the ESA framework.

Requirements and Mission Conditions

From the present point of view, around the year 2005, the targeted, step-by-step establishment of an autonomous European orbiting infrastructure will be implemented, for which - over a period of 10 to 15 years - a continual need for transporting personnel, large structure elements, instruments, and supply goods will be created. The supply capacities required in this time

period will remain almost constant, because at first only a core infrastructure - which presumably will not be manned permanently or with complete personnel strength - will be established. Successively, infrastructure elements will be added and personnel and corresponding supply goods will be expanded. When the set-up phase is largely completed, increased exchange and expansion of instrumentation as well as necessary supply goods will be implemented.

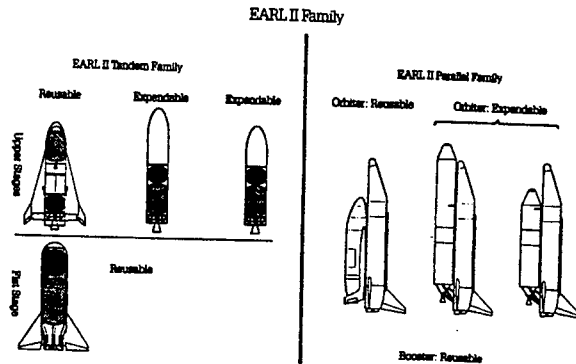

Tandem and Parallel Configurations

In an ESA study in which Dornier participated (Study Towards Autonomous Manned Spaceflight - STEAMS) - which was completed in 1988 - detailed investigations, supplying fundamental information for future transportation requirements and operational conditions for the EARL program - were made into detailed scenarios for the above-outlined development.

An essential conclusion for the conception was the above-mentioned division of the upper-stage concept into a reusable manned vehicle (orbiter) and a very much lighter, non-reusable injection stage for heavy payloads. The orbiter will be implemented primarily for regular support of the space station and co-orbiting platform(s) as well as for instrument exchange and special returnable payloads. Heavy payloads, such as large structure elements and pressurized modules for constructing the space station or launching satellites into transfer orbit to GEO (GTO) for planetary missions, requires no return capability. For that reason, they are flown with very much less expensive injection stages - derived from the Ariane 5 diverted, pure-injection first stage.

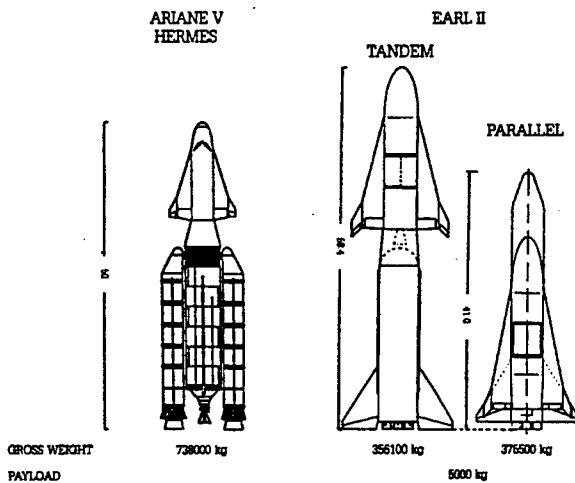

Space Transport Systems—Size Comparison of Ariane 5/Hermes and EARL II

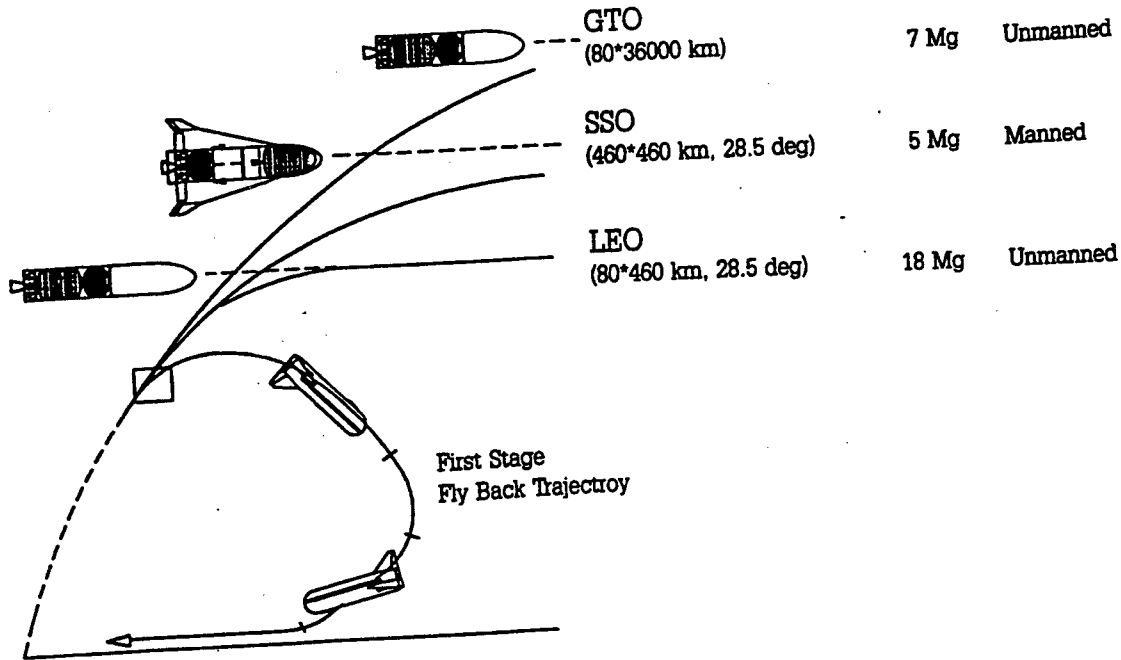

Space Transport Systems—Size Comparison of Ariane 5/Hermes and EARL II

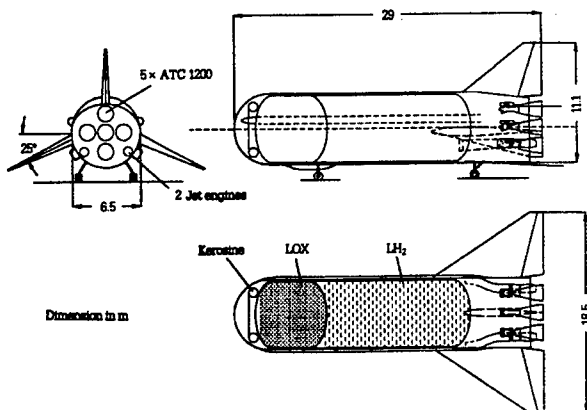

Technical Construction of the First Stage

For the orbiter version of the EARL concept, previously studied in detail, results corresponding to the above-mentioned scenarios were achieved for the following mission and operational conditions:

Operational Conditions (Manned Version)

- 5 Mg pure payload for MTFE or ESS.
- Return with total payload capacity (5 Mg).
- Duration in orbit: 4 days.
- Nominal launch rate: five manned flights per year.
- Payload volume: 80 cubic meters.

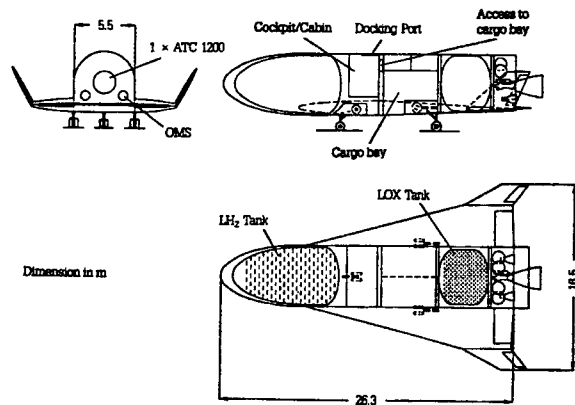

Technical Construction of the Upper Stage

- Accommodation of an airlock in the payload bay possible.
- Use of an autonomous transport container possible (for example, a flight-hab for personnel transportation).
- Nominal crew: 2 + 2 (pilots and scientists).
- Expansion of the cabin for use as a rescue capsule.
- Pressurized cabin volume: 20 cubic meters.
- Maximum acceleration: 3.5 g.
- Flight stability and minimal bending stress during ascent through active level control of the aerodynamic surfaces.

- Arrangement of tanks (mass distribution) under consideration of the stability during return and landing flight. (Upper stage: re-entry profile as well as aborting with full tanks).
- Orbital operations of the upper stage
- Approach to MTF and ESS.
- Docking by means of an external docking port.
- Access to a pressurized payload in the payload bay (for example, flight-hab) by means of an internal docking port.
- Service operations for the cabin using a carried-along manipulator.

Safety Concepts (Manned Version)

- Rescue possibilities for the crew from launch to landing.
- Expansion of cabin as Crew Escape Module (CEM), similar to the present Hermes concept.
- Use of the rescue cabin in cases in which the orbiter cannot fly (for example, explosion of the first stage in the take-off phase) any rescue maneuvers (for example, aborting), and shortly before an emergency landing on water.

Configuration and Operation

Configuration of the EARL concept is derived primarily from the combination of the available technologies for the above-described transportation market situation. That means, with the projected launch rate, an already fully reusable and operationally economical system derived from present European technologies (Ariane 5

and Hermes) is preferable. In contrast to this, a technological leap, such as represented by Sanger, means considerably higher development costs, which can be justified only with considerably higher launch rates. This leads to a classical rocket concept, which means a vertically ascending launcher without aerodynamic lift on a rocket trajectory. Both rocket stages are to be provided with wings, in order to be able to return aerodynamically to the launch location or an alternative landing site with relatively high mission flexibility. For the first stage, this means a propelled return flight with help from two conventional jet engines fed from an auxiliary kerosene tank, while the orbiter possesses a corresponding cross range.

The propulsion to be used is a high-pressure series wound jet engine in the thrust class 1200 KN, based on the Advanced Topping-Cycle (ATC) technology being developed by MBB. A vacuum engine with an expansion rate of 325 is planned for the orbiter, and five engines with shortened and modified jet with an expansion rate of 77.5 are planned for the first stage.

The arrangement of EARL will be optimized for the mission profile of the manned version, by setting the presently planned orbit of the future autonomous European Space Station (ESS) at 460 km above earth. After the stage separation around 60 km above earth, the orbiter will be accelerated by the main engine into an elliptical transition orbit. When the apogee is reached 460 km above earth, both maneuver (OMS) engines will produce the circular thrust.

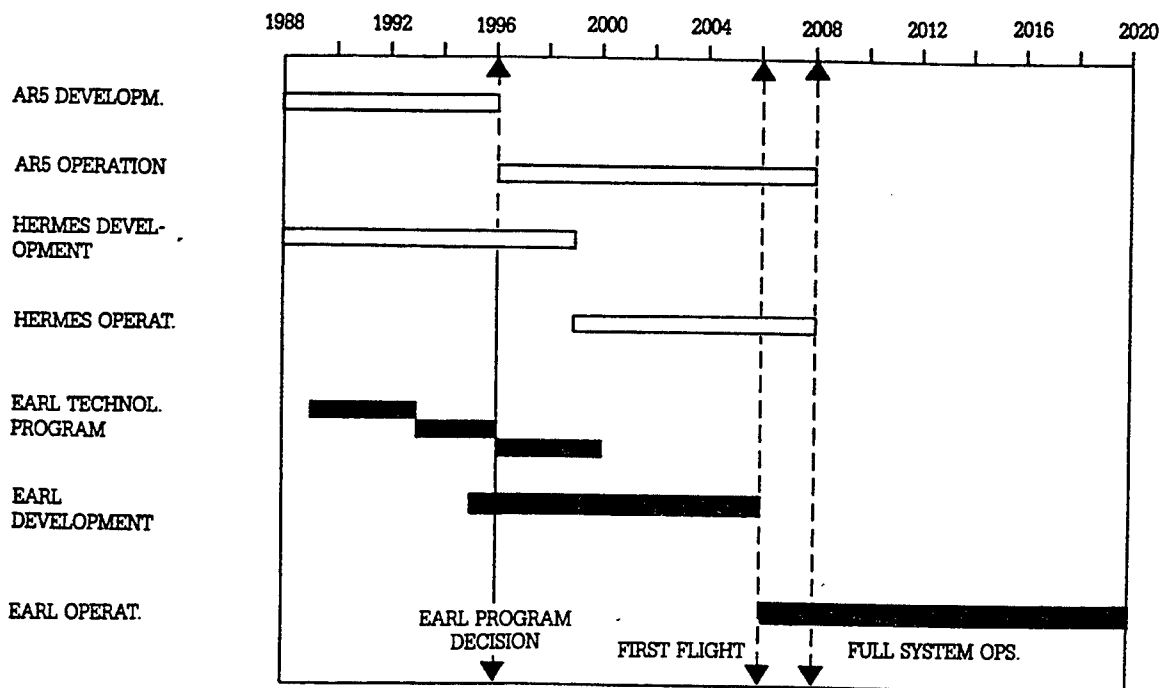

Space Transport Systems—EARL Program

After separation, the first stage flies on a ballistic track and brakes upon entry into the thicker atmosphere layer with no angle of incidence. At around 40 km above earth, a re-entry looping followed by gliding phase is initiated through aerodynamic steering. In this phase, the first stage slows to under the speed of sound (Mach 1) and shortly thereafter the jet engines are fired to a low-altitude return-to-earth of the first stage at Mach 0.5.

Technology and Development Scenario

The basic philosophy of the EARL concept is based on an evolutionary development of technologies already existing or already well along in development. Innovation leaps, required for air-induction first stages or even single-stage, are burdened by high development risks, and thus are avoided. On the other hand, the degree of further development should demonstrate a clear improvement of performance beyond the present technological level (Ariane 5/Hermes) and help build a bridge in the direction of such ambitious systems as Sanger, in which - early on - a series of key technologies can be taken from application and brought to the required level of development for these future systems. Especially the Sanger upper stage, Horus, is in its present size and arrangement and its technology requirements so similar to the EARL II orbiter, that a person can speak of a single development line with periodical modified versions following one another.

A central point in the technology development for EARL will be the further development of cryo tanks for liquid oxygen (LOX) and liquid hydrogen (LS2), and especially their suitability to reusability requirements, as well as inspection and maintenance accessibility. For the first stage, the integrated construction method of these tanks can be taken from experiences with Ariane 5, while a massive development program must be planned for the orbiter (which includes non-metallic structure and tank construction, insulation between hot and cold structure, and new inspection/maintenance procedures) because of very high thermal stress and very different integration requirements.

A further central point is formed by the propulsion system for both stages. As already mentioned, this system will be based on the currently developed ATC high-pressure technology, which also is planned for the Horus propulsion. Due to cost reasons, a derivation of the Ariane 5 HM60 engine, adapted to vacuum operation, will be developed for the non-reusable unmanned upper stage. Here it can be seen that there is, with EARL, a bridge-building function from the present level of development to the Sanger-class transportation system.

Further technological milestones, which require high priority in the EARL development and technology program are:

- Further development of the heat-protection system used in Hermes.

- Further development of a crew-rescue system (CEM) using Hermes technology (CEM).
- Aerodynamic and return system for the first stage (engine, avionics/GNC).
- Aerothermo and aerodynamic arrangement of the orbiter based on Hermes experience.
- Stage separation methods for re-usable tandem and parallel stages.
- Fuel transfer for the parallel-stage rocket.

In order to insure that EARL is ready for implementation according to the current timetable for the corresponding transport requirements, a targeted technology program in addition to the hypersonic technology program for Sanger should be started immediately. A program decision for EARL should be reached after a short pre-development phase at the latest by 1996 - in order to make the first flight possible by 2005 to 2008 - and take up regular activity after the Ariane 5/Hermes programs have concluded.

	Reusable		Expendable Upper Stage	
	Baseline		LEO	GTO
	Mg	Mg	Mg	Mg
First Stage				
Propellant for Ascent	226.5	211.9	211.9	211.9
Kerosene	5.8	5.8	5.8	5.8
Dry Mass	39.5	37.0	37.0	37.0
Misc. Propellant	4.4	4.1	4.1	4.1
Second Stage				
Propellant for Ascent	72.0	64.8	67.3	67.3
Dry Mass + Crew	25.1	23.2	6.2	6.2
Propellant for ACS/OMS	3.1	3.0		
Misc. Propellant	1.4	1.3	1.4	1.4
Payload	5.0	5.0	22.4	8.8
Total	382.9	356.1	356.1	342.5

Arianespace's 1989-1990 Launch Schedule Detailed

89MI0425 Rome AIR PRESS, in Italian
25 Jul 89 p 1518

[Text] Arianespace has published its launch schedule beginning from August 1989 through the end of 1990. The schedule starts with the TV-SAT 2 and Hipparcos launches in August 1989, which were originally scheduled for the end of July and later postponed when TV-SAT 2 was slightly damaged following a heavy storm in Kourou. The chart below includes the Italsat launch, which is scheduled for September 1990 in an F42 mission. This mission is designed to launch the Italian satellite together with the European Eutelsat IIB. An

Ariane 4 will be used for all the launches. Ariane 4 is the new version of the European rocket and provides Arianespace with the appropriate flexibility to meet customers' specific requirements. Over the last 22 months,

Arianespace's 14 launches have placed 22 satellites into orbit. As of 11 July, Arianespace's launch backlog included 35 satellites for a total value of approximately \$2.3 billion.

Launch	Month	Ariane	Satellite
33	8/89	44LP	TV-SAT + Hipparcos
34	10/89	44L	Intelsat VI F2
35	11/89	40	Spot 2 + Auxiliary Payload 1 (*)
36	12/89	44L	Superbird B + BS-2X
37	2/90	44L	TDF 2 + DFS 2
38	4/90	44P	Eutelsat IIA + MOP2 or
		(44LP)	Skynet IV
39	5/90	44P	Skynet 4C (or MOP 2) +
		(42P)	GSTAR IV
40	6/90	44L	SBS-6 + Galaxy VI
41	7/90	44L	Intelsat VI F5
42	9/90	44L	Eutelsat IIB + Italsat 1
43	10/90	40	ERS 1
44	11/90	44L	SATCOM K3 + Inmarsat 2F3
45	12/90	44P	Anik E1

(*)Auxiliary payload 1=Microsat

A,B,C, and D + UOSAT D and E

Italy's BPD Develops Propulsion Subsystem

89MI0408 Rome AIR PRESS in Italian 4 Jul 89 p 1368

[Text] BPD Defense and Space (SNIA-BPD Group) has contributed to the Olympus program by developing a liquid bipropellant propulsion subsystem. The system is the first of its kind to be developed in Italy. This technology subsequently enabled BPD to take part in several other programs, such as EURECA [European Retrievable Carrier], Italsat, and Columbus. The Olympus propulsion system combines the apogee orbit transfer functions in one piece of equipment to enable the satellite to acquire geostationary circular orbit, as well as the attitude control functions that guarantee the satellite's working life. The first function is carried out by a 450-Newton thrust rocket engine, while the second is carried out by a dual system comprising 16 rocket engines, each providing a thrust of approximately 22 Newtons. These engines run on monomethylhydrazine (fuel) and nitrogen tetroxide (oxidizer) supplied by two spherical titanium tanks fitted with an internal mechanism. The mechanism has no moving parts and, from the sole action of the surface tensile forces of the liquids, provides the exact flow of propellant in a gravity-free environment. The system is completed by four high-pressure (270 bar) helium gas tanks that guarantee the prescribed engine feed by means of a pressure regulator, and a set of fluid adjustment and control pipes. The whole unit was "sterilized" at the BPD Defense and Space plant at Colleferro (Rome). The most demanding

standards were observed to ensure the absence of contaminated agents and consequently the smooth operation of the system throughout the expected duration of the mission. This development involved considerable investment on the part of BPD Defense and Space, both for the plant and equipment and for personnel training. This will adapt the company's capabilities to the requirements involved in satellites of the Olympus type and, in the future, to the requirements of space station propulsion systems. Investments amount to approximately 7 billion lire. The total cost for the development and production of the Olympus propulsion system is approximately 25 billion lire.

Italian Company Develops Robotic Aid Prototype for Space Stations

89MI0424 Rome AIR PRESS in Italian
25 Jul 89 p 1517

[Text] The ESA (European Space Agency) has approved the first prototype of a "space tool," developed and built in Europe, which can be used either by an astronaut or a robotic arm. The tool consists of a wrench for use in assembly operations outside space stations. Approval was granted following the usual environmental tests, as well as tank tests to simulate gravity-free conditions in the presence of an astronaut. The wrench is the first device to be supplied by TecnoSpazio, a company whose shareholders include COMAU and FIAR, and which operates in the robotics and space automation sectors. The wrench was developed as part of a technological research

program conducted by Sener and referred to as "Extra Vehicular Activity Robotic Aids."

European Microgravity R&D Coordinated in Italy

89MI0393 Rome AIR PRESS in Italian
12 Jul 89 p 1433

[Text] MARS (Microgravity Advanced and User Support Center) of Naples, an agency set up by Naples University and Aeritalia, has signed two scientific cooperation and space user support agreements with MUSC (Microgravity User Support Center) of Cologne, and ZARM [Center for Applied Space Technology and Microgravity] of Bremen. These agreements, which were signed at the fifth Columbus Symposium, formalize existing cooperation agreements and are concrete evidence that the European space community is already bringing European countries together to achieve major scientific goals. The agreements concern the development of joint research projects and experiments in the fields of microgravitational fluid dynamics, production of materials in space, space physiology, and biology. The periodic exchange of information and researchers, program integration, and joint use of laboratories is also envisaged. This project provides students and researchers with a better opportunity to carry out microgravity experiments while making the best use of existing resources.

DEFENSE INDUSTRIES

Belgium's Military Aviation Policy Criticized

89AN0244 Brussels INDUSTRIE in French Jun 89 p 3

[Article by Paul Louyet: "Industry in Danger!"]

[Text] Belgian aircraft manufacturers—Grouped within the Belgian Aerospace Equipment Manufacturers' Group (GEBECOMA), the Belgian aircraft manufacturers are: ACEC, Bell, Dassault, FN Moteurs, MBLE, Sabca, and Sonaca—are not happy; they feel that government decisions, or rather indecision, amount to a death threat. The cause is the defense minister's refusal to participate in the development of a new fighter aircraft to replace our "Mirages" at the end of their useful life.

The aircraft manufacturers assert that such a program is vital for the survival of the Belgian aviation industry. Putting it bluntly, without the Rafale or the Eurofighter there can no longer be any hope of profitable participation in the future Airbus or Ariane programs.

The Belgian manufacturers' argument makes sense: The disarmament negotiations do not affect aircraft, and it will therefore be necessary to maintain a sufficiently large air force. The programs that are currently being proposed represent the final opportunities for several decades: A new fighter aircraft is not launched every 6 months. None of these programs includes the three major European countries—France, West Germany, and

Britain—which means that the proportion of work that would fall to our industry would be far greater than it would be within the framework of a pan-European program.

Moreover, only a military program could give our aircraft manufacturers the funds for the necessary investments and research efforts for their civil sector activities. In fact, our aviation industry is already characterized by weak R&D activity, involving only 5 percent of its personnel, whereas the European average is 23 percent. To remain credible in this high-technology field, this research effort must grow. According to our manufacturers, this is only possible as part of the development of a fighter aircraft. Nonmilitary orders would not in themselves be sufficient to recoup the cost of these investments.

The ball is therefore in the political authorities' court. They must decide whether budgetary constraints should override industrial needs. For, once again, the problems we face concern industrial policy: Either Belgium should maintain a place in the aviation sector, in which case the necessary resources should be allocated to manufacturers; or the game is not worth it, in which case funding should stop.

However, such logic is probably only wishful thinking: Has it not been vaguely mentioned that, given the lack of funds in the defense budget, Flanders and Wallonia (which from now on are responsible for research matters) should bear the expense of developing the fighter aircraft? Yet such an industry seems to us to be certainly relevant to the national interest, if only because of the profit that the other industrial sectors can derive from the repercussions of its technological innovations. Moreover, our Dutch neighbors have demonstrated that "the strength of a dynamic aviation industry does not necessarily depend on a country's size nor on the size of its domestic market, but on a long-term strategy."

We therefore fear that, because of procrastination and indecisiveness, the aviation sector will go the same way as our nuclear industry, which today is confined to the simple task of maintaining existing power plants, and is deprived of any future prospects in the face of the European giant that has just been formed by the Siemens-Framatome alliance!

FACTORY AUTOMATION, ROBOTICS

Use of Robots in Belgian Industry Assessed

AN890245 Brussels INDUSTRIE in French
Jun 89 pp 57, 59

[Article by Eng. G. Denuit: "Poor Belgian Robotics!"]

[Text] Robotics, an advanced technology, is a valuable indicator of the way a country is modernizing its industry and preparing for its future. Although Belgium

is in a position to understand the importance of the single European market, the least one can say is that no one is worrying too much about preparing a competitive industry for the coming years.

A quick statistical analysis indicates that, slowly but surely, Belgium is falling behind in robotics, as the following table shows:

Country	Number	Growth 1986-87 (in %)
1. Japan	143,000	+23
2. USA	29,000	+16
3. FRG	14,900	+20
4. Italy	6,600	+32

Country	Number	Growth 1986-87 (in %)
5. France	6,577	+25
6. UK	4,303	+17
7. Sweden	2,750	+15
8. Belgium	1,132	+10
9. Spain	1,131	+24
10. Australia	925	+16

After having been recognized as a pioneer in this field, mostly because of its automobile assembly plants, our country fell rapidly into a period of stagnation in terms of the number of robots in use. In fact, Belgium currently no longer ranks among the top 10. But, even more than a number, it is the growth rate of our robot stock—one of the lowest in the world—that should concern us.

The following table illustrates the history of this phenomenon.

Year	1982	1983	1984	1985	1986	1987	1988
Number of robots	119	153	261	200	60	82	100

Late Discovery

Belgian statistics thus represent the combination of two trends:

—On the one hand, massive investment by automobile assembly plant subsidiaries (Ford, GM, Renault, Volvo), essentially in spot-welding robots, which are relatively simple in technological terms and which have been operational since the beginning of the decade.

—On the other hand, a belated and tentative discovery by other industries of the virtues of robotics.

Two figures further illustrate the ridiculous nature of our situation: At the end of 1987, there were 105 machine-loading/unloading robots and only 13 assembly robots in our country. Thus, the situation is not quite that of the "job killers" described by robot opponents only a few years ago.

Whose Fault Is It?

This troubling situation is the result of decisions, attitudes, and behavior, but also of economic realities.

First of all, corporate executives are often unaware of the technological possibilities of robotics and only see the risks associated with investing in them or integrating them into an environment that is hostile to automation. At the outset choosing robotics is difficult to justify, but once it has been fully mastered one sometimes bitterly regrets that it was not adopted earlier.

Undercapitalization, the influence of trade unions, a lack of internal organization and long-term planning, short production runs, nonforceful high-level technical staff, a lack of confidence on the part of financiers in their technical staff: All these factors help slow down the adoption of new technologies, and robotics in particular.

As for robot suppliers, who are too numerous in Belgium given the tight market, they are competing among themselves for the few customers. Suicidal discounts and technical recklessness have to some extent ruined the market; they have discouraged potential customers through poor results and have driven away many reputable suppliers.

Finally, the authorities are still investing too much in basic technologies, even though, inherently, Belgium has no future in this field. We should manufacture better what we already manufacture well, through the use of robots. We should not be trying to build robots! A fortune has been wasted in this way, through supporting abortive projects, when it is so simple to encourage modernization in firms that are already performing well. It is true that high-technology investment is encouraged, but these efforts are too vague and too tentative.

Hope

Without a doubt, any hope for change rests with people. A major effort on the part of technical schools and universities has produced young engineers trained and extremely interested in robotics. It is up to them to reach positions within the hierarchy where they can make decisions or, at least, persuade decision-makers. But how much longer will this take?

FRG: Dornier's Catia Robot System Described

36982690 *Friedrichshafen DORNIER POST in English*
No 2, 1989 p 109

[Article by Peter Putz, Werner Kortwinkel: "Catia Capabilities and Special Catia Robotics"]

[Excerpt] [Passage omitted]

Dornier has installed the Catia system for purposes of mechanic and kinematic robot system development. Catia (Computer-graphic Aided Three dimensional Interactive Application) is one of the most capable and versatile CAD/CAM software packages. Its special modules and capabilities needed for robot development are described below.

Catia Base

—Developing interactive dialog and access model data banks and local functions of the intelligent display terminal (for example, zooming, dynamic three-dimension transformations, shadowing).

Catia Three-Dimensional Design

—Constructing and producing three-dimensional surface models (for example, representation as wire model or without covered edges).

Catia Advanced Surface

—Definition of even more complex surfaces as possible using three-dimensional designs.

Catia Solid Geometry

—Defining and analyzing volume models (solids) from primitive and complex building components (quadrants, cylinders, spheres, prisms, tubes, and rotation bodies) through quantum-theory operations, as well as representation without covered lines or as shadowed pictures.

Catia Robotics

—Interactively defining any number of robots by linking geometric models comprising any number of joints and prescribed movement possibilities as well as movement limitations and coordinate systems.

—Defining power/moment on robots (through their own weight or contact).

—Interactively producing and editing robot programs in a very flexible advanced language (among others, arithmetic and logic operations with variables or sensor data, various program operations logic commands, and subprogram technology).

—Analyzing robot models in three-dimensional design and, additionally, calculating the reaction power and moment.

—Simulating resulting robot movements in the three-dimension model (trick-film type animation with high degree of reality), by representing robot status (joint and universal coordinates, proximity to limits, sensor and time status), examining possibility of analytical interference (collision), and studying traces left behind of moved objects.

—Recording movement data for transformation into the language of the actual robot (off-line programming).

As can be seen, a wide range of functions is offered. Often it is possible to make do with the simple and rapid modeling through Catia Solid Geometry and only to call upon three-dimensional design or Advanced Surface for especially complicated robots or environment geometry. Catia Drafting or the interface to Cadam is used to develop working drawings. Catia Kinematics, which can model and simulate general kinematic systems (for example, closed loops, as well as more-complex links like winding, screwing, or turning belt drives).

Catia is installed in the Dornier computer center on an IBM-compatible system (Siemens Comporex) running under the operating system MVS-XA and is used primarily with graphic terminals IBM 5080 with keyboard, function keys, and rotation commands.

FIAT's FRG Subsidiary, Trumpf Group Develop Laser Robot

89MI0396 *Coburg OPTO ELEKTRONIK MAGAZIN in German* Vol 5 No 3, May 89 p 223

[Text] Two of Europe's largest machine tool manufacturers have joined forces to develop and produce a robot laser. According to FIAT Deutschland GmbH, the companies are Trumpf GmbH and Co, of Ditzingen near Stuttgart, and the FIAT Group's Comau SpA of Turin, producer of integrated automated processing systems. The goal of this cooperation is a highly sophisticated robot laser for use in the automobile industry and in other fields.

SCIENCE & TECHNOLOGY POLICY

Increased Research Budget Probable in 1990

35190167a *Paris LES ECHOS in French* 7 Jul 89 p 8

[Article by Philippe Escande]

[Text] Barring any last minute surprises, the civilian research and development budget, which covers the research spending of all ministries except for the Ministry of Defense, should grow next year at a rate comparable to its growth this year (7 percent in current francs), which would take it to more than 45 billion francs (nearly 3 billion more than this year).

The increase is expected to benefit the research institutions, aeronautics, and industrial research. Nearly 1 billion additional francs could therefore be released for operating expenses at the large institutions (CNRS

[National Center for Scientific Research], INSERM [National Institute for Health and Medical Research], INRA [National Institute for Agronomic Research]), primarily for salary increases.

Aeronautics will also be favored in view of the start-up of numerous new programs. Research on the elongated version of the Airbus A320 will cost between 250 and 300 million, while the new generation CFM56 motor developed by SNECMA will also require large sums. In fact, capital grants are even being considered in place of reimbursable loans, both for SNECMA and Aerospatiale in connection with the Airbus program.

Industrial research is another designated priority. The budget for ANVAR [National Agency for the Enhancement of Research] may thus receive an increase of nearly 20 percent (compared with 25 percent last year) for a total nearing 200 million francs, while the Technological Research Fund, which oversees the broad avenues of technology (such as large technological projects and advances), will be given slightly less than 1 billion francs. That amount falls short of the hopes of the ministries of research and industry, which were counting on 1.2 billion, 4 times more than in 1989.

The one uncertainty is the fate of the research program for the SPOT IV satellite, the total cost of which exceeds the billion-franc level and which may consume nearly 200 million as early as next year. The verdict from the Matignon [prime minister's office] is expected by next week.

SUPERCONDUCTIVITY

Dutch TNO Upgrades MOCVD Technique

89AN0268 Rijswijk PT AKTUEEL in Dutch
5 Jul 89 p 1

[Article: "TNO Announces Breakthrough in Thin-Film Superconductors"]

[Excerpts] Researchers from the Netherlands Organization for Applied Scientific Research (TNO) in Zeist have developed a method for evaporating barium compounds that will considerably simplify barium oxide deposition processes. According to TNO, this constitutes a breakthrough in the production of thin films for new ceramic superconductors.

Barium is an essential element in these new superconductors. Over the past 2 years, a number of new materials have been discovered that become superconductive at temperatures of minus 200 degrees Celsius and higher. The most interesting compounds are those containing barium, copper, calcium, or strontium oxide. [passage omitted]

Overheating

It is generally assumed that the new materials are better suited for low-voltage applications than for high-voltage

applications. In low-voltage applications, thin films of the new materials are deposited on the appropriate substrate. In the Netherlands, researchers from Philips, TNO, and several universities are working on this as part of the National Program on High-Temperature Superconductors.

For the industrial production of thin films, the so-called MOCVD technique (metal-organic chemical vapor deposition) is used. [passage omitted] The most commonly used films are those consisting of yttrium-barium-copper oxide and thallium-barium-calcium-copper oxide. However, due to its size, barium is difficult to vaporize into a suitable compound. So far, barium compounds have been evaporated by overheating, but this causes decomposition and therefore complicates the use of barium compounds.

Oxygen

TNO researchers have found a solution. They realized that a metal atom evaporates more easily when it has no electric charge and can no longer link up with chemical elements in its direct environment. In their experiments, they used alkaline earth metal compounds that are currently known to be the easiest to evaporate (calcium, barium, and strontium). In barium compounds, each metal atom is surrounded by four oxygen atoms. By adding electrically neutral and oxygenous substances (polyethylene-glycol-ethers), they were able to increase the number of oxygen atoms surrounding a barium atom to eight or more. This prevented the barium atom from adhering to other barium atoms during the evaporation process and allowed the evaporation temperature to be reduced to 150 degrees Celsius. Previously, temperatures of 270 degrees Celsius were not unusual. Similar results have been achieved with calcium and strontium.

TNO has already applied for a patent and expects the first product to be ready within a few years.

TECHNOLOGY TRANSFER

Soviet Economist Comments on Computer Joint Ventures

89MI0391 Milan ITALIA OGGI in Italian
20 Jul 89 p 41—FOR OFFICIAL USE ONLY

[Article by Roberto Frazzoli: "ESPRIT Appeals to the USSR"]

[Text] One of the first consequences of the new detente between the USSR and the West is an easing of restrictions on high technology exports to the East. This particularly applies to computers, which are greatly needed in the USSR. Western experts estimate that there are approximately 500,000 processors in the country, including personal, mini, and mainframe computers, while the overall requirements are estimated to be about 3 million units. Domestic production amounts to approximately 90,000 IBM-compatible personal computers (of the less powerful type, AT models at the best)

and 100,000 minicomputers (clones of the Digital Pdp 11 mini). As early as 1985, Gorbachev announced the introduction of an ambitious computer training plan with aid from the West, for both the schools and for training a large number of programming analysts. In fact, the most recent joint ventures between Italy and the Soviet Union announced by Olivetti and Finsiel have involved the development of software and computer services with major training support.

While the new economic policy gives more than 200 Soviet companies the opportunity to buy goods directly from the West, few of these manage to do so because of a failure to obtain bank loans. Consequently, joint ventures remain the main channel for high technology imports, and their number is steadily increasing. Yuri L. Levine commented on these joint ventures and the link between computer science and perestroika in a brief interview with *ITALIA OGGI* at the International Dataquest Conference. Mr Levine is an economist at the Soviet Institute for World Economics and International Relations, an economics research institute.

ITALIA OGGI: How is the USSR's electronics and computer market growing?

Levine: As you know, our country is a centrally planned economy, and the market on the whole is not highly developed, although this is a field of major interest. What I can say is that the demand is oriented toward IBM-compatible PCs. Some are assembled by joint-venture businesses in the USSR, others are imported, while the software is most often developed domestically. We have good programmers.

ITALIA OGGI: What about the electronics trade with the West?

Levine: The level of our economic relations is developing; the best opportunities are to be found in Europe because European countries are our main business partners: FRG, Finland, Italy, France, and the UK. We are counting on the development of joint ventures—one reason is to encourage the development of domestic resources in these sectors, in other words, to strengthen domestic production.

ITALIA OGGI: Are European research projects, such as ESPRIT [European Strategic Program for R&D in Information Technologies] of interest?

Levine: I do not know of any negotiations underway, but I think the idea could prove very interesting. Joint research programs in the area of electronic technology also exist within COMECON [Council for Mutual Economic Assistance]. There are many experts in the USSR and in other East European countries. If we were to join in the ESPRIT project as well as in other European programs, mutual benefits would ensue. But... I do not think that COCOM [Coordinating Committee for Multilateral Strategic Export Controls], the agency which controls the export of western technology to the East, would agree.

TELECOMMUNICATIONS R&D

Netherlands PTT To Invest in ISDN

89AN0320 Newbury *BENELUX ALERT* in English
31 Aug 89 p 15

[*BENELUX ALERT* Summary of Report in Rotterdam NRC *HANDELSBLAD* in Dutch on 19 August 1989 p 15]

[Text] The Netherlands PTT plans to invest at least 500 million guilders in Integrated Services Digital Network (ISDN) by 1995. ISDN is a telephone network which can simultaneously transmit sound, image, and computer information using the same connection. PTT expects that ISDN will receive a lot of use in the Netherlands, because not only is it quicker and more reliable than the existing network but it also offers a lot more possibilities. PTT will test its ISDN network in Rotterdam in October 1989, 4 months behind the other European networks. The experiment will last 3 years and will cost about 15 million guilders. Robeco, investment trust company, will be one of the companies subscribing to ISDN during its testing period. ISDN is expected to be launched commercially in four major Dutch cities in 1992. Only in 1996 will the whole of the Netherlands be able to be connected to this new network. Charges for being connected to the new network will be higher than for the present network.

Government Funds for High Definition TV Allocated

55002485a Paris *LE QUOTIDIEN DE PARIS* in French
24 Aug 89 p 9

[Article by Francois Labrouillere; first paragraph is *LE QUOTIDIEN DE PARIS* introduction]

[Text] The Ministry of Industry next year will grant Fr 240 million for the development of high definition television (HDTV). However, the difficulties of the first European television satellites bode ill for the future of the D2 Mac [multiplexed analog component] standard supported by France.

Yesterday the Industry Minister, Roger Fauroux, chose the occasion of the opening this week in Berlin of the International Hall of Sound and Video, the largest public electronics exposition in Europe, to reveal his policy for television standards before the Council of Ministers. The television of the future—called high definition television by specialists because the number of lines making up the picture will be somewhere close to twice the 625 lines of the present European Secam [Sequential Memory Color] and Pal [phase alternation line] standards—is the big prize of the end of the century for the leisure electronics industry. A cinemascope screen and pictures approaching movie theater sharpness; compact disc quality digital stereo sound; larger, flatter televisions: The HDTV revolution promises to rival the transition from black and white television to color.

It is a colossal market of tens of billions of francs for the manufacturers. All equipment, without exception, from cameras to control rooms to television sets, will be redesigned within the next 10 or 15 years. These forecasts already whet the appetites of the industry giants, names like Sony, Hitachi, Philips, and Thomson, who are all jostling for domination. The battle will take place essentially in the arena of standards. The CCIR, the International Radio Consultative Committee, is supposed to rule next year on adopting a single worldwide standard for HDTV.

Just as the appearance of color television in the mid-sixties saw a confrontation among France's Secam, Germany's Pal, and the NTSC [National Television Systems Committee] of the Americans and the Japanese, so the development of HDTV will pit against each other the European D2 Mac standard (Thomson and Philips), the Japanese Muse [Multiple Sub-Nyquist Sampling Encoding] Hivision, and a hypothetical, not yet finalized American standard.

Major Challenge

"High definition television is a major challenge for the French electronics industry and the European Eureka program," the French industry minister reaffirmed vigorously yesterday. To prove his good will, he has promised to double the funds budgeted for HDTV, allocating Fr 240 million to French manufacturers in the sector (Thomson principally).

After the prototype phase, the minister wants the makers to jump to the real thing. "The manufacturers," he says, "should now develop products for mass production to satisfy the requirements of audiovisual production companies and ultimately the authorities."

Talks are underway, Roger Fauroux has announced, which should result by mid-1990 in the ultimate phase, "more expensive and therefore naturally more ambitious," of the European Eureka EU95 project. The industry minister is also announcing an active French policy "to have the international authorities embrace the European norm; to prevent the United States from

adopting the Japanese standard; and to convince the natural allies of Europe, such as the USSR, China, Australia, and Africa, to rally to its standard."

Gray Areas

It may be that these efforts will be too little to assure the manufacturers of victory in the HDTV wars. Many gray areas still shadow the Europeans's D2 Mac standard. First, in contrast to the Japanese competition, there does not now exist a real HDTV norm (the picture is still composed of 625 scanlines) but rather a "larval version" of the future European high definition which awaits a second stage of development. The Japanese, however, have plunged ahead.

Since last 3 June, NHK, Japan's public television, has been broadcasting full blown HDTV for an hour a day on an experimental basis, and equipment built to Japan's Muse standard is already turning up quietly in the production studios of the major worldwide television networks.

The direct television broadcasting satellite TDF1, on which France was counting to establish the D2 Mac standard, is also far from fulfilling its promise, to put it euphemistically. Going on a year after its launch last December, the satellite, which cost billions, still malfunctions. La Sept [Channel 7] the new public channel broadcast by TDF1, is doubtless the only worldwide television without viewers!

Faced with a lack of enthusiasm on the manufacturers' part, the PTT [Postal and Telecommunications] minister had to take things in hand, ordering in the spring from Radiotechnique (the French subsidiary of Philips) 750,000 D2 Mac TDF1 decoders, which will not be available until the start of the new year! This plus the lack of enthusiasm of television viewers for the programs on the other European satellites makes the future of the D2 Mac standard look rather hazy for the time being. There is one consolation: Mikhail Gorbachev seemed to enjoy very much a demonstration of European HDTV last July at the Elysee. History does repeat itself. The USSR was also one of the few major foreign countries to adopt France's Secam for its color television!

COMPUTERS

Bulgaria's Microclass Computer System Described

22020011 Sofia ELEKTROPROMISHLENOST 1
PRIBOROSTROENE in Bulgarian No 7 Jul 89
[Signed to press 11 Nov 88] pp2-4

[Article by Senior Research Associate Aleksandur K. Aleksandrov, M. S. in Engineering, Liliana A. Hristova, M.S. in Engineering, Yavor S. Visulchev, Engineer, Dimitur T. Tonev, Georgi D. Demirev, Engineer: "Microclass: Computer Class Using the Pravets 16 Personal Computer"]

[Text] Computer class is a system of interconnected personal computers equipped with a set of hardware and software and used for state-of-the-art teaching and self-teaching.

The basic functions of computer class are as follows: to conduct lectures; to conduct exercises and self-teaching; to check students' knowledge; to document the education process; to prepare lectures.

To achieve the objectives of computer science education and related academic subjects, the computer class must allow the functioning of local networks, ways to communicate with other systems, translators, applied program packages (word processing, database), and others.

Microclass is a flexible computer system with a wide range of hardware and software. In addition, it is capable of satisfying the requirements for a fairly inexpensive

computer system (for schools' needs, for example), as well as for building powerful processing systems which function as trainers.

We will discuss the Microclass configuration and its basic software.

System Structure

Microclass is a heterogeneous system consisting of a main computer (for the teacher) and study stations (for the students), connected in a "star" configuration (Figure 1).

Either Pravets 16 (US [Unified System] 1839) or Pravets 286 (US [Unified System] 1838) can be used as the main computer.

Pravets 16 is built with a K1810VM88 microprocessor, 640 Kbyte RAM, 360 Kbyte capacity floppy disk drive, 10 Mbyte capacity hard disk drive, color image monitor, and an M88 printer.

The system using Pravets 16 can serve up to 8 stations.

The Pravets 286 main computer is built with Intel 80286 microprocessor, up to 3 Mbyte RAM, 10/20 Mbyte capacity hard disk drive, and 360 Kbyte or 1.2 Mbyte capacity floppy disk drive. The system using Pravets 286 can serve up to 16 stations because the productivity of the Intel 80286 microprocessor is several times greater than that of 8088.

In addition to the above mentioned main computer configuration, one or two KS-Microstar cards (controller

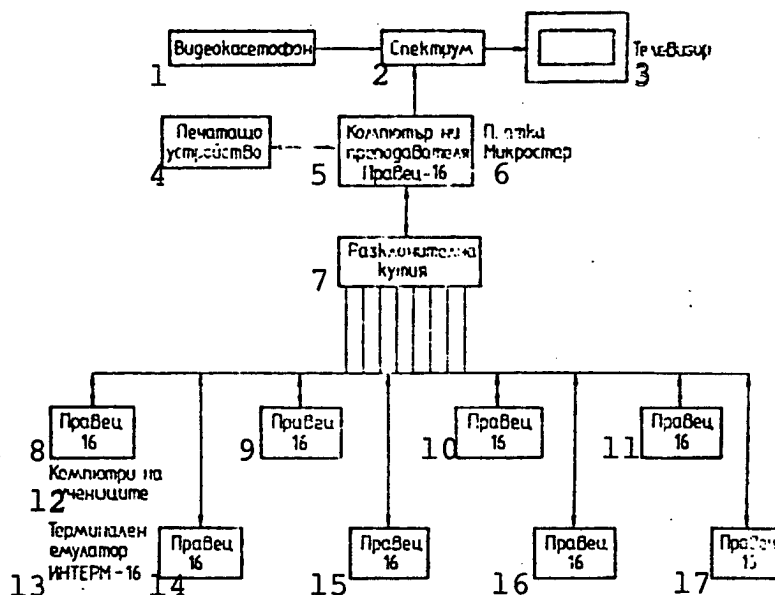

Figure 1.

Key:—1. Video cassette recorder—2. Spektrum card—3. Television set—4. Printer—5. Computer for the Teacher Pravets 16—6. Microstar card—7. File server—8.-11. Pravets 16—12. Computers for the students—13. INTERM- 16 Terminal Emulator—14.-17. Pravets 16

for 8-channel series interface) and a file server must be included. Connection with the study stations is accomplished through them.

A video system is hooked up to the main computer using the Spectrum specialized controller which allows mixing of images from the personal computer and from a video cassette recorder. The controller offers a number of possible ways to control the television set, as well as a second video cassette recorder for recording mixed images.

The stations connected to the main computer can be either terminals or personal computers. All terminals of the SM 1604 family (word processing mode only), Tektroniks 40HH (including graphics mode) and others are compatible with the system.

Pravets 82 type 8-bit personal computers, Pravets 8M, or the 16-bit Pravets 16 can be hooked up to the main computer as smart stations.

Pravets 82 is built with a 6502 microprocessor, has a 64 Kbyte RAM, two floppy disk drives with 160 Kbyte capacity each, and an M80 printer. The configuration can be upgraded with additional 128 Kbyte memory, language card containing single board microcomputer with a Z80 microprocessor, and a series interface board. All additions to Pravets 82 are built in Pravets 8M.

Basic Software

Microclass is offered with a wide selection of software for the various configurations.

Software products for the main computer or stations with Pravets 16 available are as follows: multiuser multitask operations system PDOS-16, Microterm terminal emulator, Interm-16 terminal emulator, editing screen RE2, BASIC interpreter, macroassembler, FORTRAN-77, PASCAL, and C compilers, Microstar local network software, relational data base with network functions, and others.

Software for Pravets-82 includes DOS 3.3 operations system, BASIC interpreter, CP/M operations system (with language card) with a range of translators for PASCAL, FORTRAN, and other languages, applied program packages such as PFS filing system, word processing and others, and a range of programs for self-teaching.

The Microclass system is based on PDOS *operations system* which provides for multitask and multiuser work. PDOS-16 formats a section of RAM for each of the terminals hooked up to the main computer where system and educational programs are loaded. The system functions on a time schedule serving commands from the terminals. PDOS-16 permits definition of terminal type, choice of RAM section size, priority of the section, the amount of time, and so on. A queue is formed by the commands for work from the terminals with the printer or disk drives. A solution for the problem with programs executed on terminals which operate directly from the

video controller memory has been found. This type programs are started under the control of a system program which then redirects output data to the terminal.

One of the most important functions of the system which enables it to form computer classes, is the possibility to observe the screens of the stations from the main computer by depressing the appropriate key combination.

The Microterm terminal emulator is intended for use with Pravets 16. It enables the Pravets 16 station to function as a VT52 (SM 1604, SM 1604M1 and others) terminal of the main computer. In addition, it is possible for the personal computer to carry out its own program and function as either a personal computer or terminal, switching it back and forth by pressing a combination of keys simultaneously. It is also possible to transfer data files back and forth between the main computer and the station. If the terminal emulator is loaded on the main computer, it can function as a terminal for the SM computer-SM 4, or the IZOT 1055, as well as transfer data files between the computers.

Interm-8 terminal emulator is intended for use with Pravets 82 or Pravets 8M. It enables the personal computer to function as a graphics terminal of the Tektroniks 40HH type. *The Interm-16 emulator* provides the same possibilities for Pravets-16 to function as a station. It also permits the transfer of data files back and forth between the main computer and the station. The data can be text or binary which allows Pravets 8M programs to be stored in Pravets 16. Further development of Pravets 8M software is the possibility to enter and carry out programs on the Pravets 16 disk drive, as well as the reverse (tape from the Pravets 8M memory on the Pravets 16 disk drive).

The language of the Tektroniks 40HH graphics terminal permits the transfer of information in compressed form for mapping dots and straight lines. The specialized Microclass software is based on this language.

If the Interm 16 emulator is loaded into the main computer it can establish a connection with the SM computer or the IZOT 1055.

The Microclass operations mode as a multiterminal system is intended mainly for use in giving lectures and exercises with the participation of a teacher.

In cases where the system is composed entirely of 16-bit computers, Microstar network software is used in computer science teaching and self-teaching. Microstar uses the same system configuration ("star" type) and the same series controllers, that is, it is not necessary to build in special network controllers. The maximum exchange speed within the network is about 110 Kbit/sec. The main computer acts as a "server" when used with the local network by providing virtual disk space and printing. This means that all study stations can use its hard disks and printer as if they were their own.

An advantage of network software over the multiterminal system is the ability of each station to use its own computer. In the multiterminal system the station works only with a limited part of the main computer memory and uses its processor. On the other hand, by using network software, the teacher cannot supervise the students' work. For this reason, this mode is used by the students mainly for self-teaching or with systems using 8-bit personal computer stations.

The remaining software products for 16-bit personal computers are intended for developing programs and teaching computer science. They can function in a multiterminal system mode, as long as they have sufficient RAM. The BASIC interpreter, which can function only on the main computer, is an exception.

Several drivers are included with the basic software for the main computer: driver for memory expansion, driver for video system control, and driver for magnetic tape cartridges.

The memory expansion driver enables the operations system PDOS-16 of Pravets 286 to use memory over 1 Mbyte according to the LIM-EMS standard.

The video system control driver makes it possible to redirect text and graphics to the video system where they are mixed with the video signal received from the VCR and are sent to a television set to obtain color imaging or are taped on another VCR. These data are sent simultaneously to the main computer monitor as well.

Magnetic tape cartridges are used in cases when the Microclass system functions with material which requires that the information be protected from destruction. This applies mainly to Pravets 286 where upgrading with a similar device is expected, even though it is not included in its standard configuration.

The driver for magnetic tape cartridges makes it possible to file disks or disk file devices on a magnetic tape and the reverse: to restore disk files from file copies on magnetic tape cartridges.

The proposed configurations and Microclass basic software make it possible to produce specialized software for a whole range of computer classes. The basic characteristics of Microclass which make it applicable to education are:

the ability to observe the terminal screens of the multiterminal system;

the ability to send mixed text and graphics images from the main computer to the terminals;

local network mode with hardware compatible with a multiuser system;

the ability to mix video signals from the VCR with text and graphics information supplied by the computer.

The Microclass system is used by ECTU Electronic Systems, in Sofia. It complies with the normative requirements of a similar class (published in bulletin No. 3/1986 of the MNP [Ministry of People's Education]). The Spektrum and KS-Microstar cards are produced by the Institute for Microprocessing Equipment, Sofia, by special order of the client.

RTV 2000: Basic Software for GDR's CAD/CAM Applications

23020089 East Berlin RECHENTECHNIK-DATENVERARBEITUNG in German
No 8, Aug 89 pp 29-31

[Article by Dr. Heinrich Haberland, Reinhard Britsche, Karl-Heinz Bondick, VEB DVZ Magdeburg; Wolfgang Weiss, VEB SONNI Sonneberg; Volkmar Olbrich, VEB Conveyer Systems "7 October", Magdeburg; "RTV 2000 Product Line for CAD/CAM Applications"]

[Text] With the development of the RTV rationalization solution for computer-aided technical preparation for production, its continuing enhancement, and successful application in various combines for more than 10 years, comprehensive expertise is available (1) through (8). A significant factor in this is the enduring cooperation of industrial firms, university facilities, and the developer collective of the DVZ [data processing center] Magdeburg in the RTV user group.

The increased availability of modern workplace-oriented computer technology opens innovative capabilities for computer support to a broad range of users.

For this, important considerations for software suppliers include continuity for users and attractiveness to the newcomer. The VEB DVZ Magdeburg is meeting these requirements on behalf of the VE Data Processing Combine Berlin with the production of RTV 2000 as flexible modern basic CAD/CAM application software which will continue to be productive over the long term.

The focus of current developmental work at the VEB DVZ Magdeburg is on enhancement of the basic software already licensed for many uses in the national economy:

- the database operating system DAFEMA (9) for support of distributed processing and for management of CAD/CAM structures,
- communications software ZNSP/TCAM, DATRA for regional remote processing networks and for integration of modern computer network technologies,
- the basic RTV solution for computer-aided technical preparation for production using workplace computer technology within the framework of a distributed data processing and data management system (Fig. 1).

In the company organizational cycle, computer-aided technical preparation for production [RTV] follows planning and production management and precedes production. RTV applications support the creation and

Figure 1. Basic Integrated CAD/CAM Software Package

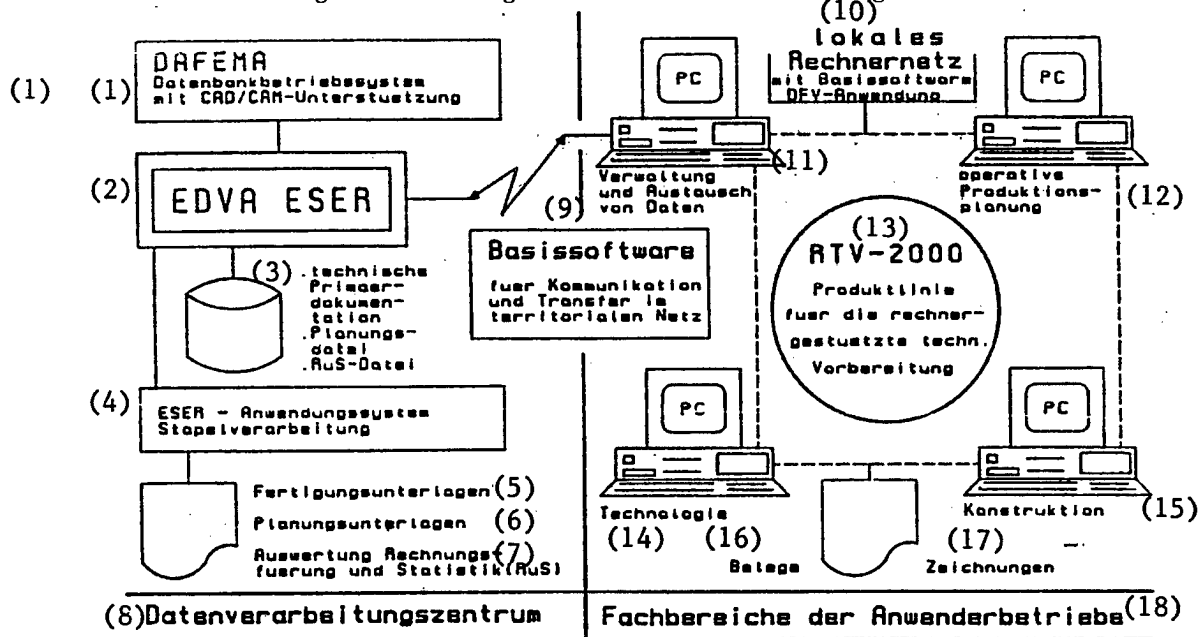

Key:

1. DAFEMA database operating system with CAD/CAM support
2. EDP ESER
3. Primary technical documentation, planning files, calculation and statistical files
4. ESER Application system, batch processing
5. Production documentation
6. Planning documentation
7. Evaluation of calculation and statistics
8. DP Center
9. Basic communication and transfer software in the regional network
10. LAN with basic software remote DP application
11. Data management and exchange
12. Operational production planning
13. RTV 2000 Product line for computer-aided technical preparation
14. Technology
15. Design
16. Documentation
17. Sketches
18. Technical department of the user firm

elaboration of the records for technical documentation. The company-specific models stored in RTV form the basis for this. The results are made available in a central on-line database (preferably DAFEMA) for multipurpose use. User-computer communication and user modeling are based on the establishment and use of user-specific descriptive technical terminology.

Application Functionality

The hardware design includes the use of efficient CAD workstations and the use of centralized ESER electronic

data processing for database management with data transfer. The software design implements the functions of a two-component CAD software system divided into the general basic solution and the company-specific application built on it.

Standardized customization and handling of user applications is carried out efficiently using CAD/CAM tools (technical terminology generator, technical terminology compiler, mask editor, sequence processor for determining and continuing the processing of sequences).

Figure 2. Structure and Functions of RTV 2000

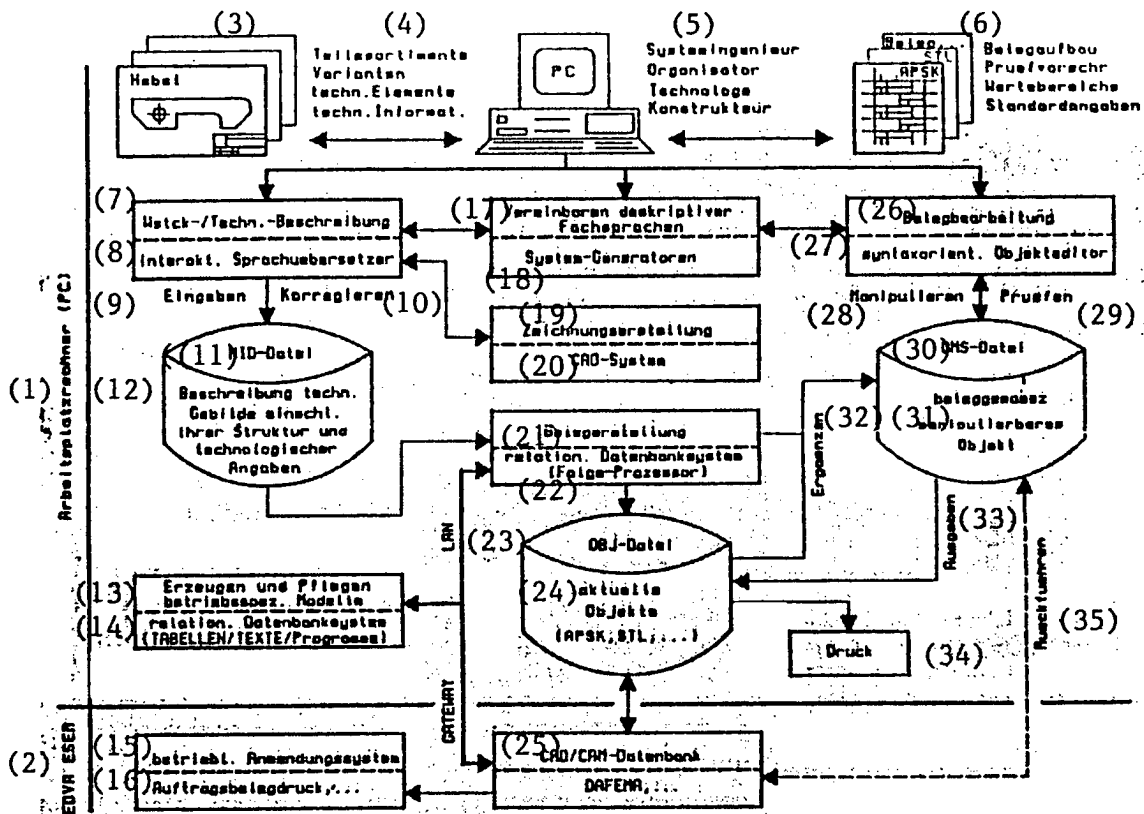

Key:

- | | |
|--|--|
| 1. Workplace computer (PC) | 17. Establishment of descriptive technical terminology |
| 2. EDP ESER | 18. System generators |
| 3. Switch | 19. Sketch generation |
| 4. Parts catalog, variants, technical elements, technical data | 20. CAD system |
| 5. Systems engineer, planner, technical expert, design engineer | 21. Record generation |
| 6. Record organization, test rules, value ranges, standard data | 22. Relational database system (sequence processor) |
| 7. Tool/technology description | 23. Object files |
| 8. Interactive terminology compiler | 24. Current objects (APSK, STL,...) |
| 9. Input | 25. CAD/CAM database |
| 10. Correction | 26. Creation of documentation |
| 11. MID files | 27. Syntax-based object editor |
| 12. Description of technical formations including their structure and technical data | 28. Manipulation |
| 13. Generation and storage of company-specific models | 29. Testing |
| 14. Relational database system (tables/texts/programs) | 30. DMS files |
| 15. Company-specific application system | 31. Record [illegible] manipulable object |
| 16. Job record printing,... | 32. Expansion |
| | 33. Output |
| | 34. Printing |
| | 35. Looping |

An expandable system design with flexible functionality is at the disposal of the user application developer (Fig. 2).

Functions of the Basic Level

- Through establishment of user-specific descriptive technical terminology, any records can be described with full complexity.
- With the description of records record organization, test rules, standard value agreements, file organization, and output patterns for monitor display and printing of records are established simultaneously.
- Building on that, the comprehensive generation of the user application takes place (screen masks, data structures, formatting).
- In addition, variable inclusion of user routines is possible (test, presetting, and calculational programs).
- The generated result provides computer-aided elaboration of the records described (capture, processing, storage, modification, evaluation, display, printing, use) simply and with efficient user support.

Functions of the "Ratio" Level

- The "ratio" level includes comprehensive enhancements of the basic level with a view toward efficient creation of records.
- After generation in the basic level, significant system components of the "ratio" level are immediately available (record structure, files, interaction structures).
- Using terminology conventions, application-specific technical terminology is supplied for tool and technology descriptions.
- The rationalization result achieved is basically determined by the level and scope of the model description which is carried out using tables, variable text procedures, and dynamic built-in user programs.
- The description and storage of design tools supports connection with the sketch generation system which is present.
- Expanding on that, computer-aided generation of records for components and individual parts is assured.

Handling

Whereas the basic level permits rapid and uncomplicated access to computer-aided operations with broad rationalization results, the "ratio" level requires, depending on the automation results desired, greater expenditures in terms of preliminary thought and preparation of the model description.

The "ratio" level may be broken down into different developmental steps, beginning with the storage of individual normative guidelines and standardized texts, continuing through programs to calculate time and materials planning needs and automatic programming, ending in the complex elaboration of processes.

The individual areas of activity and requirements of the various user groups (planners, technical specialists,

design engineers) on the one hand as well as the systems engineers on the other hand are thoroughly taken care of. The comprehensive generative capabilities are productive tools in the progressive development of the user application and its timely updating. Understandability is achieved through close integration and uniform handling of the functions for elaboration and creation of all records as well as through support for application-specific user operation.

In addition to appropriate application documentation and central training, technical support services are offered to the user through the VEB DVZ Magdeburg.

Modes of Use

RTV procedures and results are illustrated from the user viewpoint through three selected examples of applications:

Solution for Typical Mechanical Engineering Production

For many years now, the VEB Central Repair and Supply Facility (ZRAW) Gommern of the Petroleum/Natural Gas Combine, a combine with primarily small to medium-sized production series based on the workplace principle, has been working with DVZ Magdeburg on the licensed use and design of a rationalization solution for computer-aided technical preparation for production. To date, four task complexes have been worked out for routine operation using the RTV system (4):

- Generation of technical documentation, for example, APSK's [working plan master cards], master cards, work instructions, time calculations.
- Transfer of technical documentation recorded on data acquisition devices to the central database.
- Design and management of the central database, including the search capability (database-specific) and technical update service.
- Conversion of company-specific documentation (working plan master cards and parts lists) to the central data processing document TAB I.

All task complexes are supported by interactive monitor dialog (remote data processing) with the ESER computers in the VEB DVZ Magdeburg. Computer-aided generation of technologies is performed for the parts catalog of transitions, flanges, and general rotationally symmetric parts.

For technical specialists, the outlay for preparation of workpiece descriptions is thus reduced. The APSK's generated are stored directly in the central database, forming the basis for subsequent projects such as materials and capacity planning. The database has a projected capacity of approximately 50,000 technologies.

RTV offers the potential for comprehensive solutions for problems arising in production preparation.

Thus, with computer-aided creation of technologies, capacity economies of approximately 50 percent occur. The accuracy of technical documentation is increased.

To take advantage of decentralized computer technology, a technical specialist workstation on the PC 1715 was designed at the VEB ZRAW Gommern for capture, modification, and generation of technical documentation. Use with 16-bit technology (EC 1834) is under development.

Solution in the Toy Industry

Licensed use and application of the basic RTV solution by the VEB SONNI Sonneberg is being implemented in cooperation with the VEB DVZ Suhl with the support of the VEB DVZ Magdeburg. The objective (with a completely new solution for this industrial sector) is to master calculation of material and time outlays to achieve higher flexibility relative to market requirements through exact production data (5). In the VEB SONNI Sonneberg approximately 6,000 products are manufactured with an innovation rate of approximately 50 percent.

For product-oriented production, the basic typical RTV solution from mechanical engineering is used effectively, with new organizational forms opening up for technical preparation for production in this firm at the same time.

The first section of the company-specific rationalization solution was implemented for production after 12 months. For this, not only were the data for the APSK's generated, but parts lists and materials kits were produced completely from the product description and stored in the database.

Actual use is interactive with the ESER computer of the DVZ Suhl. An overall savings of technical specialist time of approximately 60 percent (13 hours per APSK) and a reduction in the time needed for generation of documentation during development of new products of approximately 80 percent (from 12 weeks to an average of 1 week, even to 1 to 2 days if need be) are achieved.

Solution for Typical Steel Fabrication

The basic RTV solution in the VEB Conveyor Systems "7 October" Magdeburg (FAM) is based on particularly complex user requirements. The design and application of an integrated CAD/CAM system is being implemented in close cooperation with the VEB DVZ Magdeburg, using both workplace-based computer technology (at the user site) and central ESER electronic data processing (at the DVZ).

The following components have been implemented:

- Design, servicing, and use of the central database,
- Tie-in of the automatic belt conveyor design system of the VEB FAM with transfer of design data to the central database, for calculation of materials needed, among other things,
- Revision of technical production documentation for

individual parts and assemblies of steel products using the basic RTV solution along with stored production data from the firm.

Work is in progress on development of a CAD belt conveyor system (6) for computer-aided generation of sketches and its tie-in to the company-specific CAD/CAM concept of the VEB FAM (7). Design of standardized user interfaces for the various partial systems is being carried out based on problem-based technical terminology. With full implementation of the comprehensive solution, the time required for preparation of all production documents will be reduced through computer-aided technical preparation by 75 percent compared to manual procedures. Faster delivery of products and increased competitiveness on the international market will be achieved through the significantly reduced time spent on preparation for production.

Abstract

The RTV 2000 product line includes flexible basic software for computer-aided elaboration and creation of documentation, specifically for the tasks of technical preparation. It is distinguished by the use of modern workplace computers with different levels of performance as well as uniform handling of systems for different user groups using CAD/CAM tools and descriptive technical terminology to be agreed to. This permits designing specific user-computer interfaces with efficient user operation including comprehensive generation of company-specific applications. Selected methods and functions are used for development, storage, and dynamic servicing of company-specific models. They support the elaboration of documentation according to the similarity, variant, and generation principles and guarantee reproducible results.

An orientation to comprehensive data processing using modern communications technology and the connection of databases on ESER electronic data processing is provided.

The provision of efficient file interfaces permits integration with a view to a long-term CIM strategy.

Bibliography

1. Kupper, H.; Roscher, G.; "Program System for Computer-Aided Technical Preparation (RTV)," FERTIGUNGSTECHNIK UND BETRIEB, No 7, 1975.
2. Haberland, H.; Kautz, A.; Roscher, G.; Zerressen, H.; "RTV Rationalizes Technical Preparation," RECHENTECHNIK-DATENVERARBEITUNG, No 7, 1981.
3. Becher, H.; Britsche, R.; Dolle, B.; Haberland, H.; Mayer, K.-W.; Roscher, G.; "New Paths for Computer-Aided Technical Preparation for Production," EDV-ASPEKTE, No 4, 1984.

4. Schoenemann, F., "Computer-Aided Technical Preparation (RTV) in the VEB ZRAW Gommern: Contributions to CAD/CAM," Colloquium at the DVZ Magdeburg, Brochure, Oct 1985.
5. Weiss, W.; Mueller, H.; Zettwitz, M.; "The Teddy Bear in the Computer," FREIES WORT, Apr 1986.
6. Schuetze, B.; Deh, U.; Basteck, A.; Schulz, E.; "Experiences With a Product Model for the 'Belt Conveyor' CAD System," Fourth Congress of GDR Information Scientists, INFO 1988, Dresden, Feb 1988.
7. Hoerber, H.; Olbrich, V.; "Design for a CAD/CAM System—Presented Using the Example of the Belt Conveyor," 12th Colloquium Design Engineering, Technical University Magdeburg, Mar 1988.
8. Dippmann, D.; Duerr, H.; Haberland, H.; Mayer, K.-W.; Roscher, G.; "Problem-Based Input for CAD/CAM Tasks," WISSENSCHAFTLICHE ZEITSCHRIFT DER TH MAGDEBURG, 1986.
9. Riewendt, P., "DAFEMA Database System for Remote Processing," RECHENTECHNIK-DATENVERARBEITUNG, Vol. 17, No 12, 1980, pp 24ff.

MICROELECTRONICS

GDR Produces 32-bit Microprocessor

23020091p East Berlin NEUES DEUTSCHLAND in German 15 Aug 89 p 1, 3-4

[Text] The Microelectronics Combine in Erfurt has produced the first functional model of a 32-bit microprocessor chip which can be applied at engineering workstations for the automated design of electronic circuits, other electronic equipment and products for the machinebuilding sector.

The new microprocessor is the result of intensive efforts over a three-year period by more than 250 specialists from R&D collectives including the Microelectronics Combine in Erfurt, the ROBOTRON Combine and the GDR Academy of Sciences. The new development will ostensibly pave the way for the manufacture of a new generation of computers requiring less power consumption and having smaller mass. The breakthrough also represents an effective means for the GDR microelectronics industry to circumvent in-force COCOM restrictions against the importation of 32-bit microprocessor technology.

On a surface area measuring 84 square millimeters, the new microprocessor chip links together 130,000 transistors and has 68 external connections for which latter, a new sheathing technology had to be developed.