

095115

JPRS-WST-84-005

7 February 1984

West Europe Report

SCIENCE AND TECHNOLOGY

Reproduced From
Best Available Copy

DISTRIBUTION STATEMENT A
Approved for public release;
Distribution Unlimited

19990107 078

FBIS

FOREIGN BROADCAST INFORMATION SERVICE

REPRODUCED BY
NATIONAL TECHNICAL
INFORMATION SERVICE
U.S. DEPARTMENT OF COMMERCE
SPRINGFIELD, VA. 22161

DTIC QUALITY INSPECTED 3

6
45
A03

NOTE

JPRS publications contain information primarily from foreign newspapers, periodicals and books, but also from news agency transmissions and broadcasts. Materials from foreign-language sources are translated; those from English-language sources are transcribed or reprinted, with the original phrasing and other characteristics retained.

Headlines, editorial reports, and material enclosed in brackets [] are supplied by JPRS. Processing indicators such as [Text] or [Excerpt] in the first line of each item, or following the last line of a brief, indicate how the original information was processed. Where no processing indicator is given, the information was summarized or extracted.

Unfamiliar names rendered phonetically or transliterated are enclosed in parentheses. Words or names preceded by a question mark and enclosed in parentheses were not clear in the original but have been supplied as appropriate in context. Other unattributed parenthetical notes within the body of an item originate with the source. Times within items are as given by source.

The contents of this publication in no way represent the policies, views or attitudes of the U.S. Government.

PROCUREMENT OF PUBLICATIONS

JPRS publications may be ordered from the National Technical Information Service, Springfield, Virginia 22161. In ordering, it is recommended that the JPRS number, title, date and author, if applicable, of publication be cited.

Current JPRS publications are announced in Government Reports Announcements issued semi-monthly by the National Technical Information Service, and are listed in the Monthly Catalog of U.S. Government Publications issued by the Superintendent of Documents, U.S. Government Printing Office, Washington, D.C. 20402.

Correspondence pertaining to matters other than procurement may be addressed to Joint Publications Research Service, 1000 North Glebe Road, Arlington, Virginia 22201.

7 February 1984

WEST EUROPE REPORT SCIENCE AND TECHNOLOGY

CONTENTS

AUTOMOBILE INDUSTRY

Volkswagen Losses Increase During First Three Quarters (AFP-AUTO, No 3362, Nov 83)	1
Fiat Introduces 'Uno' With Continuously Variable Transmission (L'ARGUS DE L'AUTOMOBILE, 27 Oct 83)	2
France's CNRS, Renault To Collaborate on Research Program (AFP SCIENCES, 22 Dec 83)	5
Briefs	
Renault Automation	6
Renault, U.S. Industrial Lasers	6

BIOTECHNOLOGY

Biogen, Greencross Market Hepatitis Antigen (CHEMISCHE RUNDSCHAU, 1 Jun 83)	7
UNIDO Focus on Third World's Biotech Needs (CHEMISCHE RUNDSCHAU, 12 Oct 83)	8
British Biotechnology Investment Fund Profiting (CHEMISCHE RUNDSCHAU, 19 Oct 83)	9

CIVIL AVIATION

Fokker Announces Two New Aircraft Projects (LE SOIR, 28 Nov 83)	10
--	----

COMPUTERS

Rhone-Alpes Region Becomes French 'Silicon Valley' (Andree Muller; TEMPS REEL, 17-30 Oct 83)	12
---	----

FACTORY AUTOMATION

Renault Shape-Recognition Robot (ROBOTS, Nov 83)	17
---	----

SCIACY Develops Modular-Robot-Elements Concept (ROBOTS, Nov 83)	19
LAAS Develops Coordinated Manipulator Control (ROBOTS, Nov 83)	21
French Press Views CAD Facilities at Peugeot (ELECTRONIQUE ACTUALITIES, 2 Dec 83)	22
Briefs	
Eyes for Machine Tools	24
SCIENTIFIC AND INDUSTRIAL POLICY	
Organization, Funding of R&D in Switzerland (Emanuel Mooser Interview; TECHNISCHE RUNDSCHAU, 13 Sep 83)	25
France's '84 Research Budget Inadequate for Programmed Goals (Maurice Arvonny; LE MONDE, 16 Nov 83)	30
Financial Status, Strategy of France's Matra (Claude Amalric; L'USINE NOUVELLE, 8 Dec 83)	32
Briefs	
New Philips Research Plan	35
Four Italian Research Programs	35
TECHNOLOGY TRANSFER	
Mail Drops in Zug in Search of Their Owners (Wolfgang Winter; DIE WELTWOCHTE, 8 Dec 83)	36
France Sells USSR Flexible Workshop With Unimate Robots (INDUSTRIES ET TECHNIQUES, 1 Nov 83)	39
Briefs	
USSR Imports Chemical Equipment	41
French Engineer Accused of Espionage	41
USSR Buys Swiss Biotech Equipment	41

AUTOMOBILE INDUSTRY

VOLKSWAGEN LOSSES INCREASE DURING FIRST THREE QUARTERS

Paris AFP-AUTO in French No 3362 AFP 231601 Nov 83

[Text] Wolfsburg, 23 November (AFP)--Losses of the Volkswagen automobile group increased during the first three quarters of the year to a total of DM 247 million (approximately \$90 million), as compared with DM 146 million during the same period in 1982, according to a letter sent to stockholders by the management of the West German manufacturer on Tuesday.

The parent company, VW AG [VW, Inc], which had still posted a profit of DM 22 million from January to September 1982, also went into the red with a loss of DM 7 million.

The group sold 1,588,000 cars, as compared with 1,623,000 during the first 9 months of 1982. Sales increased in the FRG (572,000 cars as compared with 536,000), but decreased abroad.

The report stresses the difficulties on the Brazilian and Mexican markets. In the United States, on the other hand, where VW of America lost DM 350 million last year, the situation is improving and the group is expected to make a profit.

Production decreased by 4.2 percent during the first 9 months of the year, as compared with the corresponding period of 1982, with 1,595,000 cars having come off the VW assembly lines.

Turnover worldwide increased by DM 947 million to more than DM 29 billion. Investments of DM 3.52 billion remained stable (DM 3.65 billion during the first 9 months of 1982). VW had 232,000 employees worldwide at the end of September, 7,000 less than at the end of December 1982.

It will be recalled that last year VW lost first place in turnover as a West German automobile manufacturer when it was overtaken by Daimler-Benz (Mercedes).

5586

CSO: 3698/200

AUTOMOBILE INDUSTRY

FIAT INTRODUCES 'UNO' WITH CONTINUOUSLY VARIABLE TRANSMISSION

Paris L'ARGUS DE L'AUTOMOBILE in French 27 Oct 83 p 4

[Excerpts] Working together with VDT [Van Doorne's Transmissions], Fiat has now gone past the experimental phase and plans to start production of a Uno 70 model, the Uno-matic 70, equipped with a continuously variable automatic transmission, for the summer of 1984. In 1980, Fiat had already installed an initial version of this transversion on 150 Ritmo 70's, which it consigned to selected clients (taxi drivers). The positive results obtained encouraged Fiat to pursue this approach on the basis of improvements to the system. In fact, in its initial configuration, its operation proved faulty during the engine's warmup stage following a cold start. Furthermore, shifting into forward drive or reverse was accompanied by a harsh jolt. When we test-ran the most recent version installed in a Uno 70, we found that these parasitic phenomena had disappeared and that its performance characteristics were consistently quasi-identical to those of the models equipped with mechanical transmissions.

The System...

The Uno-matic transmission, retaining the architecture of the initial version, consists of a front-end crankcase housing the epicyclic train, which is controlled by oil-bathed multiple-disk clutches. The innovation consists of using two clutches (forward drive and reverse) to smooth out the shift from neutral [or "park"] to drive or reverse, particularly while the engine is still running cold. Next comes the variator, which includes, on two parallel axles, a primary pulley and a secondary one, linked to each other by a metallic chain-belt. The final transmission uses a reducer with incorporated differential. A hydraulic control system with a gear pump to circulate oil under pressure (8 to 25 bars) actuates the pulleys and provides the lubrication and cooling of the transmission system's components.

...Operates..

Between the startup of the vehicle and attainment of the desired speed, the diameter of the pulleys varies gradually, thus varying continually the transmission ratio. The primary (drive) pulley is powered by the engine via one

of the clutches. Its motion is transmitted to the secondary pulley by the belt. At the moment of startup, the diameter of the belt loop around the primary pulley is at its minimum value (pulley fully open) and the transmission operates at its lowest ratio. During acceleration, the flanges of the primary pulley gradually come together and the diameter of the belt loop around the primary pulley increases, while the secondary pulley "opens": The transmission ratio increases until it reaches its maximum value. The "spread" between these two ratios is 5.55 for the Uno-matic transmission (5.01 with the mechanical gearbox), that is, from a ratio of 1:13,372 to a ratio of 1:2409. The spacing of the pulleys is controlled by a hydraulic system consisting of a gear pump and a set of 10 control valves that operate as a function of the position of the selector lever, the position of the carburetor butterfly valve (flexible kickdown cable), the rpm of the engine, and the spacing of the primary pulley (rpm of the primary axle). The pressure differential between the signal from the engine's Pitot-tube sensor and the signal from the primary axle's Pitot-tube sensor provides the hydraulic system with precise and instantaneous control of the clutches. A tiny mechanical probe placed between the primary pulley and the hydraulic system enables the primary-axle sensor to transmit instantaneously to the secondary valve the exact position of the pulley, that is, the exact transmission ratio. With the gearshift lever in position P [parking], the hydraulic system blocks the secondary pulley. With the motor turned off, the transmission is always in its "deadlocked" configuration.

...Smoothly!

This new dual-clutch version, with its shock absorber between the engine and the transmission's primary axle, and its improved regulation, is free of the jolts experienced on the Ritmo. Even with the engine running cold and at high idling speeds, the shift into forward drive is accomplished smoothly. Speed increases thereafter are gradual, and two "speed" ranges are available. In the first position encountered, position L (for Low), the transmission is at its best at the lower ratios: The braking effectiveness of the engine is at its maximum. In position D (Drive), operation ranges over the entire gamut of available ratios, and by depressing the accelerator pedal slightly, (to its half-way point) the transmission shifts quickly toward the higher-ratio end of the range. If the accelerator pedal is "pushed" down, transmission takes place at lower ratios; if it is "kicked" down, maximum output performance is obtained, since the engine reaches its maximum rpm while the transmission configures itself at the lowest possible ratios commensurate, however, with the instantaneous speed of the vehicle.

The response to gentle coaxing of the accelerator is smooth and pleasantly quiet. A call on it for "performance" draws a louder "snore" from the engine which continues at the higher rpms: Fuel consumption, in this case, should be expected to be higher. In normal use, the Uno-matic 70, delivering practically the same performance results as the Uno with mechanical gearbox (acceleration time slightly lower but faster pickups), achieves fuel-consumption figures comparable to those of the 5-speed version: 5 l [liters/100 km] at 90 km/hr, 6.7 l at 120 km/hr and 8.2 l in the city, versus 5 l, 6.5 l and 8.2 l, respectively, for the Uno 70 S.

Designed to equip front-wheel-drive vehicles in the small- and medium-size categories powered by 1,100 cm³ to 1,500 cm³ engines capable of developing a maximum torque of 12.5 mkg, the VDT transmission represents an economical solution for the small-sized category of cars. Barely heavier than a mechanical gearbox (16 kg but with a 6-kg clutch and gearbox power takeoffs), it checks out at comparable efficiency. For Fiat, it represents something of a venture into the future. Tests indicate that the technique is now a proven one and all that remains, before we express a definitive opinion, is to check out fuel consumption under "sports driving" conditions. The Uno-matic 70 will be marketed in early 1984, and VDT transmissions, built in Holland, will subsequently equip other models of the Fiat and Lancia lines. "Sub-contracting" their manufacture in order to minimize its risk, Fiat is taking off boldly in a new direction, while Renault and Ford have in their cards a comparable transmission.

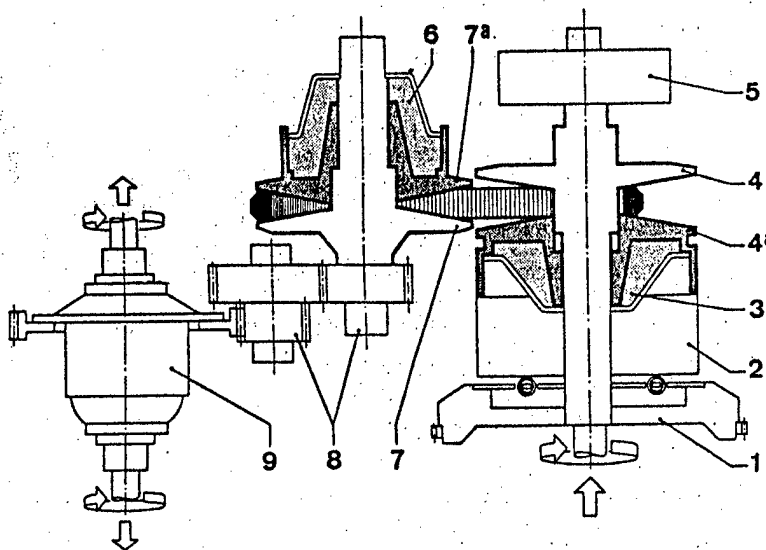

- 1) Engine flywheel; 2) Engagement clutch; 3) Oil for hydraulic control of the primary pulley; 4) primary pulley; 4a) Movable flange of primary pulley; 5) Oil pump; 6) Oil for hydraulic control of secondary pulley; 7) Secondary pulley; 7a) Movable flange of secondary pulley; 8) Reduction gear at output end of the transmission; 9) Differential.

9238
CSO: 3698/218

AUTOMOBILE INDUSTRY

FRANCE'S CNRS, RENAULT TO COLLABORATE ON RESEARCH PROGRAM

Paris AFP SCIENCES in French 22 Dec 83 p 7

[Text] The CNRS [National Center for Scientific Research] and the Renault Company signed an open-end scientific cooperation agreement on 13 December that will enable them to enlarge the scope of their present cooperation and to define research programs of mutual interest, according to a release published on 19 December.

This agreement, covering a period of 5 years, is designed to intensify the already existing collaboration between Renault and the CNRS at the basic-research level. It will also enable them to determine in the future the domains "in which their cooperation is desirable" and will facilitate entering into specific agreements on matters within its frame of reference.

It will also enable the two organizations to exchange researchers and teams between themselves for the purpose of pursuing specified lines of research.

To coordinate the research efforts to be undertaken jointly, an ad hoc committee will meet at least once a year under the chairmanship either of Mr Pierre Papon, general manager of the CNRS, or of Mr Jean Lagasse, manager of scientific and technical affairs of Renault, the signers of the agreement.

The confidentiality of the research efforts undertaken, the publication of the results obtained, their industrial proprietorship and the sharing of any profits derived from putting them to good account are specifically provided for.

Since November 1982, the CNRS has signed some dozen agreements of this nature with industrial firms and other research organizations, with a view to facilitating the putting to good account the basic research being done or being applied in their many laboratories.

9238

CSO: 3698/218

AUTOMOBILE INDUSTRY

BRIEFS

RENAULT AUTOMATION--At present, Renault Automation has contacts with firms in several countries in the area of production engineering. The state-owned company confirms in particular the possibility of an agreement, mentioned in a release by the CGT [General Confederation of Labor], with the American "Coherent" Company to form a joint subsidiary for systems using industrial lasers. It does not rule out contacts with other firms, in particular CILAS [Industrial Laser Company] a subsidiary of CGE [General Electricity Company], as desired by the CGT. Renault is also considering cooperation in the area of robots, computerized workshops with automated machine tools making various pieces of assemblies, and computer-assisted design. [Excerpt] [Paris AFP-AUTO in French No 3360 AFP 220857 Nov 83] 5586

RENAULT, U.S. INDUSTRIAL LASERS--Paris, 22 November (AFP)--"Renault Automation," which brings together the production engineering activities of the group, announced Tuesday in Paris that it has combined with the American "Coherent" Company, number one worldwide in lasers, to produce together automated systems using lasers in the industrial area. These systems will be designed and marketed by "Laser Systems," a Renault-Coherent joint company, formed by Renault taking a majority position in the capital shares of "Laser Optronic France," a French subsidiary of Coherent. They will be manufactured by Renault Automation. Renault stresses that an alliance with a manufacturer which masters all aspects of laser source technology will allow Renault to keep up with the very rapid developments in this area, while the French firm will contribute its know-how in the area of machine tools and automated systems. The project is nevertheless open to French partners. Coherent has worldwide facilities and its turnover is expected to be in the neighborhood of \$90 million in 1983. The laser has become a reliable and economical tool in an industrial environment, especially for cutting, drilling, welding or heat treatment. [Text] [Paris AFP-AUTO in French No 3361 AFP 221832 Nov 83] 5586

CSO: 3698/204

BIOTECHNOLOGY

BIOGEN, GREENCROSS MARKET HEPATITIS ANTIGEN

Solothurn CHEMISCHE RUNDSCHAU in German 1 Jun 83 p 19

[Text] Biogen, the international biotechnology firm, has announced the shipment of its first commercial product that was developed through recombinant DNA-biotechnology. The product, Hepatitis-B nuclear antigen, was sold to the Green Cross Corporation of Osaka, Japan in the form of a delivery agreement. Green Cross will use the antigen in diagnostic kits, with which human blood is to be tested for the presence of hepatitis-B.

In addition to Green Cross, Biogen has similar delivery agreements for hepatitis-B antigen with the firms Hoffmann-La Roche & Co., Ltd. and Behringwerke AG.

Biogen's work in the area of human vaccines had been concentrated on various types of hepatitis. In 1979, scientists cooperating with Biogen were the first who could report a successful synthesis of hepatitis-B antigens in E-coli bacteria. The antigen from the nucleus of hepatitis virus, which was produced in genetically constructed bacteria, is essentially identical with the natural particles of the nucleus that were isolated from the livers of infected humans. This represents a new source of nuclear-particle material, which otherwise would hardly be available.

Biogen purifies the bacterially produced particles of the nucleus and sells them in bulk. The nuclear antigen is then processed in blood-analysis kits, with which antibodies are to be isolated, to determine whether the blood donor is infected with hepatitis-B virus and in that case may be considered a carrier of this disease. Currently, blood used for blood depots is checked for surface antigens of the virus or for antibodies that are directed against the surface of the virus to detect a previous infection. When vaccines against hepatitis-B, which are produced with surface antigens from human blood, come into use, the test kits that are directed against the surface will indicate false positive values. The test kits directed against the nucleus, however, will not be affected by that and in addition should be more sensitive.

Biogen is an international company that is active in research and development through the application of biology, especially the recombinant DNA and advanced mutation techniques. These activities are keyed to producing commercially usable products for pharmaceuticals, chemistry, energy, dietetics and the mining industry.

BIOTECHNOLOGY

UNIDO FOCUS ON THIRD WORLD'S BIOTECH NEEDS

Solothurn CHEMISCHE RUNDSCHAU in German 12 Oct 83 p 16

Text The developing countries are preparing to enter into the area of microbiology. In a conference at the minister level in Madrid from 7 September through 13 September, representatives from about 50 countries established an "International Center for Gene Manipulation and Biotechnology," which is to concern itself with the problems, their solution and their application in the Third World. The UN Industrial Development Organization (UNIDO) initiated this project 2 years ago. The main purpose of the conference was to determine the site of the institution, arrange its financing and work out statutes for its functioning. Brussels, Trieste and Bangkok are conceded the best chances to be the site.

The three main functions of the center were already discussed at a UNIDO meeting last December in Belgrade. Among them are research and development in the sphere of biotechnology in areas that are relevant and interesting for developing countries. Personnel from the Third World are to be trained there, whereby the accent is to be placed on people who are capable of forming innovative groups in their home countries. The training goal is 100 people for the first 5 years. Finally, the center will serve as a point for bringing together and mediating information, data and scientists.

There were two parts to the Madrid meeting. From the 7th through the 9th of September, there was a discussion of still open questions. The subsequent meeting of ministers on the 12th and 13th of September was to pass the proposals and sign the necessary instruments for establishment of the center. Also participating in the meeting, besides the representatives of the governments, were UN organizations and agencies, intergovernmental organizations, enterprises and scientists.

9746

CSO: 3698/185

BIOTECHNOLOGY

BRITISH BIOTECHNOLOGY INVESTMENT FUND PROFITING

Solothurn CHEMISCHE RUNDSCHAU in German 19 Oct 83 p 15

Text In its second year of operation, Biotechnology Investments Fund, an investment fund of the London banking house N.M. Rothschild & Sons, Ltd. that specializes in biotechnological investments, has a number of holdings. About two-thirds of the fund's resources of \$61 million have now been invested. In the annual report, Lord Rothschild, chairman of the board, writes that "our intention is to achieve above-average profits for the capital shares in our portfolio that are not officially listed." For the last financial year, the fund that was established by Rothschild subsidiary N.M. Rothschild Asset Management shows a net increase in value of 25 percent and an increase of 35 percent for the first 2 years of its activity. Shares in 31 enterprises, from large to very small, have been acquired, mainly in the United States. The size of the investment varies from 1.2 percent for the American Agrigenetics (seed, among other things) to 25 percent for Advanced Mineral Technologies, likewise American, which is active in the areas of mining and environment. Only four of the companies participated in are now listed on the stock exchange. Involved are Integrated Genetics (Biotechnology share 4.5 percent), Applied Biosystem (7.4 percent), Amgen (1.6 percent) and Immunex (6.7 percent).

According to Lord Rothschild, selection of the fund's holdings occurs on the basis of five rules. First of all, the enterprise must not only have top-notch scientists but also a first-class management. Second, the company's objective should clearly define research and product areas by having market analyses and realistic appraisals of other competitors. Third, potential profits must be in proportion to the risk undertaken. Fourth, the enterprise must have a sponsor who functions as the leading investor and takes over responsibility for the venture. In many cases, this task is that of the investment fund itself. Finally, plans must exist to allow the investment to be judged by the market, that is, there must be an intention to take the step of going public with the stock.

9746

CSO: 3698/185

CIVIL AVIATION

FOKKER ANNOUNCES TWO NEW AIRCRAFT PROJECTS

Brussels LE SOIR in French 28 Nov 83 p 6

[Article by P.B.; first two paragraphs in boldface]

[Text] After many hesitations and postponements, the Dutch airplane manufacturer Fokker has just announced its decision to begin work on two new airplanes, the F50 and F100, with 50 and 100 seats, respectively, which will begin flight 3 years from now. The major assistance which the government is to supply in the form of loans will allow financing of the study program and preproduction expenses.

The green light given to these new programs occurs several days after the government made known its intention of purchasing 57 additional F16's, which will bring a large volume of activity to the Dutch airplane manufacturer.

The launching of two new civilian airplanes drawing on the two earlier F27 and F28 models will not end production of the latter. At present, over 740 of the F27 two-engine turboprops have been sold, while the F28 two-engine jet has passed the 200 threshold in number of airplanes sold.

The engines for these two airplanes have already been the object of preliminary contracts with specialized firms. The F100 will be equipped with Rolls Royce Tay jet engines with greater efficiency and less noise than existing engines in the F28. The Tay, which develops a thrust of more than 6 metric tons (already used on the Gulfstream), could also serve as a retrofit for the Bac 111, which does not conform to noise level standards. A contract for 100 engines has already been made by Fokker and Rolls Royce. The F100, which will be able to transport up to 107 passengers, will have a range of 2,240 kilometers. As for the F50, it will give up the Rolls Royce Dart engine equipping the present F27 for the PW 124 manufactured by the Canadian affiliate of Pratt & Whitney.

With these two new models, Fokker will be competing with models of existing planes or ones on the point of being developed. The F100 will advertise the same performances as the British 4-engine B146 jet, of which 20 specimens have been ordered recently by the American P.S.A. company, while the B50 will be a sort of replica of the French-Italian ATR 42 which is to begin test flights next year.

It may also be noted that Fokker's decision came several days after McDonnell-Douglas, which for a while was negotiating with Fokker, decided, under present market conditions, not to continue studies of new airplanes, among others the MD90 two-engine jet with 120 seats.

PHOTO CAPTION

The Fokker F100 will be an elongated version of the F28 which is pictured here. Thanks to bigger engines, it will be able to transport about 20 more passengers.

5586

CSO: 3698/200

COMPUTERS

RHONE-ALPES REGION BECOMES FRENCH 'SILICON VALLEY'

Paris TEMPS REEL in French 17-30 Oct 83 pp 59-61

[Article by Andree Muller: "An X-Ray View of the French Silicon Valley"]

[Text] The Rhone-Alpes region is often called the French Silicon Valley. Many data-processing equipment manufacturers and SSCIs [Data-Processing Consulting Companies] are established there. TEMPS REEL has investigated two especially dynamic industrial zones: the Meylan ZIRST [Scientific and Technological Innovation and Implementation Zone] and the Ecully community.

The microelectronics and software sectors are marked by the coexistence of very small specialized enterprises. They invest in relatively narrow advanced-technology industrial subsectors. In the Rhone-Alpes region, these companies show a certain specificity. They are located around Grenoble, where the ZIRST companies are developing new microelectronic products, and on the Ecully hill, where the software industry, and general data-processing services present characteristics of their own. This, of course, does not mean that these two types of industries are exclusively located in these two places. They also exist elsewhere, certainly, but the similarity and concentration phenomena that appear here deserve attention.

The first French zone when it comes to innovation, the Meylan ZIRST (Scientific and Technological Innovation and Implementation Zone) is an advanced technology park (see TEMPS REEL No 28). Located in the Meylan community, 5 km from Grenoble, it covers 65 hectares. The idea of an industrial zone reserved to innovating enterprises dates back to 1968, the decision to create it was made in 1971, and its development started in 1973; in 1983, the objective was met: by the end of 1982, the zone included close to 70 companies employing 2,700 people. Apart from the two larger companies, Merlin Gerin with 900 people and the Norbert Segard CNET [National Center for Telecommunications Studies] with 300, the remaining 1,500 are distributed among many small companies, very few of which employ over 50 people, and specialized divisions of larger French or international companies. All these enterprises are essentially involved in electronics, data processing, process control and factory automation (at least 2,000 jobs).

All-Out Innovation

The ZIRST is often called a "green area for the grey matter"; it differs from a traditional industrial zone in the purposeful selection of companies, whose operations must be oriented to technology and innovation. This is to promote cooperation and complementarity and, over the years, it has provided characteristic impetus to the zone: 25 enterprises representing over 300 jobs were created since 1975. At the ZIRST, everything is geared to innovation; for instance, the "Locazirst" leasing system has made it possible to start a number of companies which now own their premises. Let us mention AID (Industrial Dauphine Assistance), which has been at the ZIRST since 1976. It consists of a team of 30 engineers and technicians with expertise in fields as varied as mechanics and electro-technics as well as optics or fluid mechanics, who cooperate with one another to develop products in the fields of instruments, high-voltage applications, robotics and industrial physics; CEFTI (French Teleprocessing Company), created in February 1977, is a consulting company specialized in the engineering of turnkey networks; the energy division of CERCI (Industrial Cybernetics Design and Engineering Company), specialized in the implementation of automation and data-processing systems; CNET, which started with just an office; Novelec, which is involved in nuclear electronics engineering and implementation; Telematique, specialized in the new applications of electronics in process-control, telecommunications and medicine; and finally Symag, which was created in 1979 with a capital of 20,000 francs by a Grenoble University group. Its first product, the Micromachine 2000, was designed in 1980. Its facilities now have a production capacity of up to 2,000 systems per year.

Looking For Independence

The ZIRST is also a shared industrial history: when SEMS [Electric, Mechanic and Signal Company] was created in 1977, 10 or so former executives of Telemecanique decided to leave their jobs to create their own companies. Some of them created very small independent companies, others started specialized divisions in larger groups. Bernard Sempe, one of the first to leave Telemecanique, created Option in 1976. Option is an SSCM (Microelectronics Consulting Company) employing 42 people, which now belongs to the Telemecanique group. When Telemecanique acquired an interest in Option, Bernard Sempe created X Com in April 1981. X Com studies, designs and manufactures microelectronic products. It is well-known for its voice synthesis products (Sparte voice box). Roger Parriol also left SEMS and created Peripheral Assistance, a consulting company specialized in peripherals. Michel Predon, formerly in charge of industrial process-control at Telemecanique, was at the origin of the creation of a new department at CERCI. Bernard Guimier, Aldo Moro and Jean Pajus, three Telemecanique engineers, created Telematique. Claude Otrage, former assistant marketing manager at SEMS, and Geraldin Dulac, former Solar project head, created Apsis, a consulting company for manufacturers interested in computerized products. Francois Falco, also a former SEMS employee, was at the origin of the Technicon software research and development department. The list does not stop here. However, in addition to their having worked for Telemecanique or SEMS, all these men have one thing in common: they are all INPG [Grenoble National Polytechnic Institute] university graduate engineers, and all about the same age. They formed the first wave of ZIRST enterprises.

After them came other quite as characteristic entrepreneurs. These were university graduates creating their own enterprises to implement the result of their research and their ideas: the first of these enterprises was Symag; it is the only one to have started truly industrial development. It was created by two men: Louis Balme, general manager, and Pierre HERNICOT, production manager.

The second company directly issued from the university was ITMI [expansion unknown]. It was created in 1982 by a group of researchers from the Artificial Intelligence and Robotics team headed by Prof Jean-Claude LATOMBE at IMAG (Grenoble Applied Mathematics Institute). Its expertise lies in robot programming, computer vision, dedicated systems and artificial intelligence. RSI (Industrial System Design Engineering Company), a data-processing consulting company specialized in scientific computing, was created by Guy BONNARD and Jean-Paul GAUTHIER from the ENSIEG (Grenoble Higher National School of Electrical Engineering).

A dynamic group of companies cooperating to implement research, the ZIRST companies are also defining new industrial forms: the notion of competition is giving way to that of complementarity and a new form of subcontracting is appearing. Their technological subsectors often involve the most advanced technologies and will sometimes accept orders. They do a lot of work under contracts that are similar to research contracts. Yet, production remains their priority objective. It is based on small series or prototypes and, contrary to "Silicon Valley," where industries are there to take over, the ZIRST companies do not yet have downstream local industries.

The Ecully Hill, an Image

As a whole, the area west of Lyons includes many data-processing equipment manufacturers and, inside this microregion, Ecully has a choice position since 50 percent of these enterprises are located there (see boxed insert on the data-processing industry in the area west of Lyons). We should note that the larger companies are in Ecully. Yet, this is nothing new since the IBM regional headquarters have been on the hill for 30 years. Yet, during the past few years, the concentration movement has accelerated and CII-Honeywell-Bull, Hewlett Packard, Philips, SEMS, Texas Instruments, Wang, etc., are now represented in Ecully, usually by regional agencies marketing the companies' products throughout the larger southwest area.

Why this concentration? Two factors are involved: highways are near and the Lyons heavy industry is far. But Ecully is not only the regional headquarters of data-processing equipment manufacturers. In a manner somewhat similar to what happened at the ZIRST, small enterprises gather around the larger companies, looking for a certain complementarity as well as for a showcase effect.

Alain CHAUSSON, manager of the R&A Chausson SSCI, told us: "We were attracted by the image of the tertiary sector in the area west of Lyons. But, in the long run, I believe that this image will rub off on the data-processing industry." Created late in 1979, R&A Chausson is a limited-liability company specialized in the creation of application software for microcomputer-based systems. Alain Chausson confided that he is mainly looking for industrial contacts, with his suppliers (R2E [expansion unknown], Bull) as well as with other SSCIs: "I would

like, and I am therefore trying to get in touch with other SCCIs specialized in microcomputing." Therefore, the expectation for complementarity and cooperation is also present at Ecully.

Next to marketing operations, where being near the client is the first factor to be looked for, other criteria are considered. Apart from their purely geographic implications, these criteria will define new industrial modes.

Alain Chausson is categorical in this respect: "We do not coexist with other data-processing companies as competitors, but we consider ourselves as their potential partner." Emphasizing the attractive setting which, he said, "is important for data-processing companies, as it is on the side of employers that the job market is tenses," he stressed that all the new forms of work developing next to traditional employment are largely represented in the data-processing sector. These are work at home and the many forms of independent work. "Now, a zone like Ecully encourages this sort of things, and I am more likely to find this type of help and employment possibilities around here than elsewhere."

SEMS, a Bridge Between the ZIRST and Ecully

It all started with the creation of a first computer by a Grenoble University team: the Mat-01, designed in the mid-1960's by Bernard Sempe, Michel Deguerry and Jean Pajus as part of their graduating thesis at INPG. Later on, they sold their idea to the Morse Process-Control company which tentatively started manufacturing it. Soon, Telemecanique acquired the computer division of Morse and it thus financed and produced the first minicomputer: the T 2000. The latter was continued by SEMS until late 1985 [as published] (it is still in use at Elf (Feyzin), Creusot-Loire, Michelin, etc.). The first T 2000, which was introduced around 1969, was mainly an industrial computer; it was followed by the T 1600. A more universal computer, the latter expanded its field of applications to cover the scientific market, data communications and management. But these were still computers with a relatively discrete technology and little component integration. In 1975, Telemecanique then introduced more modern minicomputers, the Sola line (Solar 05, Solar 40, Solar 65). These three models are still sold today.

In 1977: first state intervention in the operations of Telemecanique which sold its computer division to SEMS, and the latter also acquired the Mitra line of CII-Honeywell-Bull minicomputers. This marked the actual creation of SEMS. Geographically, manufacturing was taking place in the Grenoble area. First at Crolles (where Telemecanique had initially started its operations). Then another unit was created at Echirolles. The two plants also specialized: the Crolles plant manufactured subassemblies, whereas assembly and tailoring to customers' needs were taking place at Echirolles. The Echirolles unit worked under contract. At the same time, all Mitra products were manufactured by a Thomson subsidiary, CITEC [expansion unknown] in Toulouse. Little by little, the Mitra knowhow was returned to the Crolles and Echirolles plants and SEMS is now fully independent in the Grenoble area. On the other hand, its marketing division moved to Lyons to be closer to its customers.

The Data-Processing Industry in the Area West of Lyons

Ecully

- R&A Chausson, ALGOE [Lyons Consulting Engineers Association], Atil, CEMP [expansion unknown], CESI [expansion unknown], CII-Honeywell-Bull, CMM Diffusion [expansion unknown], DMCS [expansion unknown], G3S Infodif [expansion unknown], Hewlett Packard, IBM.

ITT Data System France

- Jistral, Microkid, Orga-Consulting, Pica Data-Processing, Satel Com, SEMS, Silex, SMM Alcatel, Spectral, Tech Data, Texas Instrument, TGS [expansion unknown], Vickers Roneo, Wang.

Tassin

- Adrian, AM International, Car Communication, Fid Data-Processing, French Fiduciary Company--Fidorga, Helios SA, Ibis SA, Inform, Mediatec, Mingos, Nerot Data-Processing.

Dardilly

- Almex, Benson, General Electric Information Service, Gould Sel Data-Processing, Idie, INFoplus, Secopa Data-Processing, SNEI [expansion unknown], SNPMI [expansion unknown], Thor SA.

9294

CSO: 3698/227

FACTORY AUTOMATION

RENAULT SHAPE-RECOGNITION ROBOT

Paris ROBOTS in French Nov 83 p 5

[Article: "Shape Recognition by a Renault ACMA Electric Robot"]

[Text] During the Toulouse SITEF [International Future Technology and Energy Show] Renault Industries and Technical Equipment (RIET) displayed an intelligent system for shape recognition.

The knowhow acquired by the Renault Group in the area of automated production allows the design and construction of intelligent systems for sorting-handling-storing and for control.

The demonstration displayed involves as an example a laser-equipped contour analyzer connected to a Renault ACMA TH8 electric robot.

The Renault contour analyzer used the diffuse reflection of a laser beam to determine the position of objects that are identified by their contour. It detects the position and orientation of parts placed at random on a plate, sends the position data to the TH8 robot which picks up the detected parts one after another to set them down on a return ramp.

Special characteristics of this method: insensitivity to surrounding light, insensitivity to background color, detection of abutting and/or entangled parts.

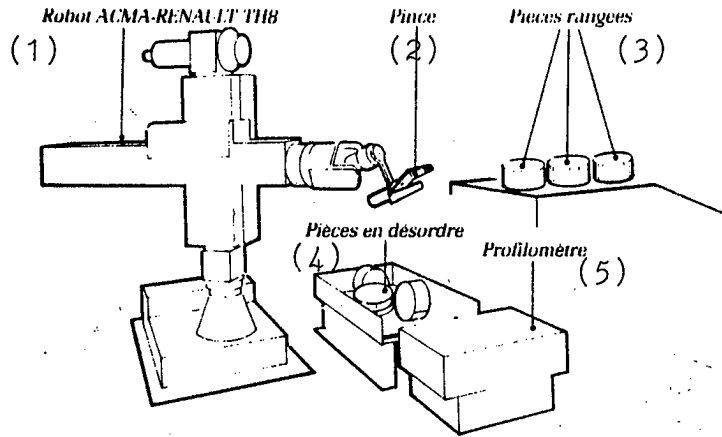

Key:

- (1) ACMA-Renault TH8 robot
- (2) Gripper
- (3) Sorted parts
- (4) Unsorted parts
- (5) Contour analyzer

12260

CSO: 3698/207

FACTORY AUTOMATION

SCI AKY DEVELOPS MODULAR-ROBOT-ELEMENTS CONCEPT

Paris ROBOTS in French Nov 83 p 7

[Article: "Programmable Modular Elements"]

[Text] Rarely are the six axes of a universal welding robot really necessary. Most of the time only two linear motions and a circular one need to be combined, or one linear motion and two circular ones, or simply one or two linear motions. Therefore, there is no need to apply the six axes of a robot and their appropriate controls, when four axes are sufficient. In any case, it is not the best solution for optimizing an installation.

After a long study of many installations throughout the world over several years, the SCI AKY solution leads to the conclusion that it is often worthwhile to dissociate the various motions so as to keep only those that are absolutely necessary. By using simple, modular, hence easily-reusable elements, one achieves increased flexibility and, therefore, versatility.

For this purpose, SCI AKY has developed programmable modules that allow to achieve all sorts of configurations when connected and fitted together like an erector set, and can thus provide answers to all the problems that one may possibly encounter. The attached drawing shows the principal types of modules that, when connected to each other, make up, for example, a six-axis robot with Cartesian, cylindrical or polar coordinates.

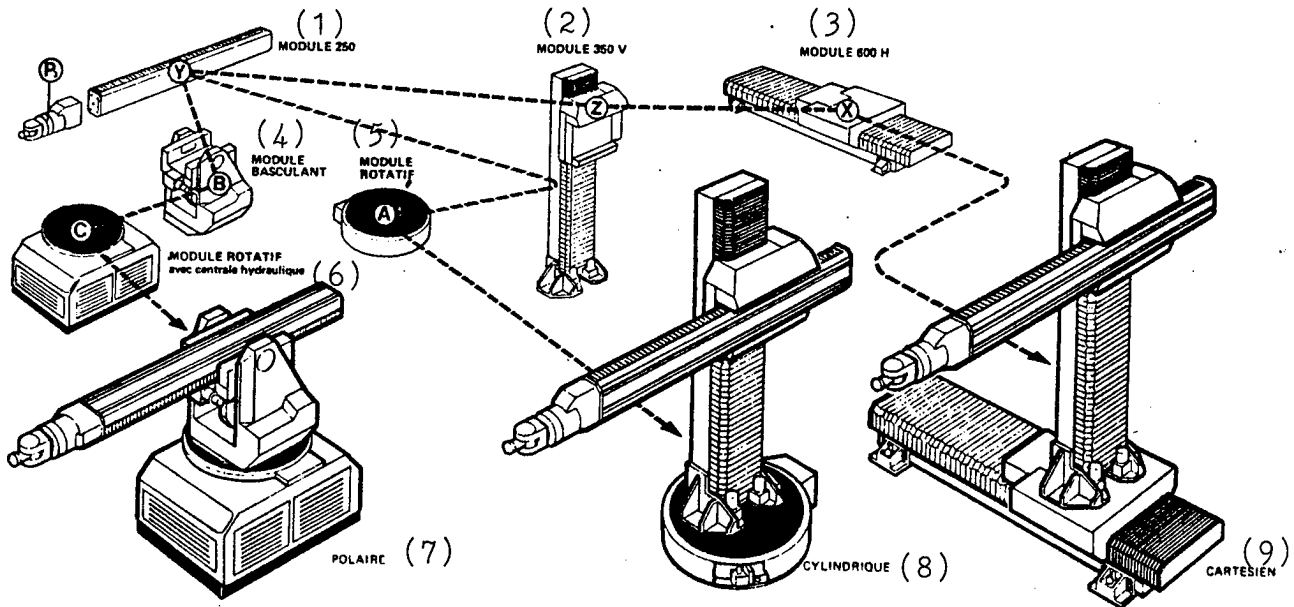

Key:

- (1), (2), (3) Module 250, Module 350 V, Module 600 H
- (4) Flipflop module
- (5) Rotary module
- (6) Rotary module with central hydraulic power unit
- (7) Polar
- (8) Cylindrical
- (9) Cartesian

12260

CSO: 3698/207

FACTORY AUTOMATION

LAAS DEVELOPS COORDINATED MANIPULATOR CONTROL

Paris ROBOTS in French Nov 83 p 6

[Article: "Coordinated Control of a Manipulator Robot's Motions"; passages in slantlines printed in italics]

[Text] During the International Future Technology and Energy Show (SITEF) in Toulouse, /LAAS (Automation and Systems Analysis Laboratory)/ displayed a coordinated control of a manipulator robot's motions.

This control is based on a modular design of hardware and software. It applies to manipulator-robots equipped with continuous-current motors; its objective is to coordinate the basic motions of the various joints to achieve real-time motion, using data received by external sensors installed on site.

--/Hardware/: a master microcomputer (16 bits INTEL) operates a network of servo-microcomputers (16 bits INTEL) through a standard multiconnection bus. Each subcomputer governs one joint through a digital interface which processes the position data given by an incremental converter and issues commands to the actuators.

--/Software/: the master microcomputer issues lists of instructions that are used by the subcomputers to ensure local feedback operation; its objective is to have the joint move in a closed loop between two consecutive stages defined by their position and their speed at a given time.

--/Testing of the prototype/: The control has been perfected on a Regie Renault TH8 manipulator robot equipped with six joints. A software program allows the operator to control the robot and to monitor its moves graphically.

--/Transfer of the control system/: the controlling software program has been transferred to the SCEMI company which used it to equip a six-axis electric minirobot that is very fast and accurate and is able to carry out complex operations. It is particularly well adapted to short-run assemblies and to frequent production changes.

For further information write to ROBOTS, number 151. (Service limited to our subscribers).

12260

CSO: 3698/206

FACTORY AUTOMATION

FRENCH PRESS VIEWS CAD FACILITIES AT PEUGEOT

Paris ELECTRONIQUE ACTUALITIES in French 2 Dec 83 p 5

[Article by H.P.: "Regrouping of the Peugeot-Talbot-Citroen CAD Systems"; passages in slantlines printed in italics]

[Text] /The PSA Research Center at La Garenne near Paris is scheduled to regroup the various technical managements of the makes that constitute the group: Peugeot, Citroen and Talbot. The most recent model that has come out of the La Garenne research department was the Peugeot 205. A part of the research for the Citroen BX was conducted on the same premises. During a recent visit organized for the press, the Center managers introduced the CAD system that will make it possible to shorten by 9 months the 4 years needed for designing a new model, up to the issue of the definition prototype/.

Scientific calculations, testing and the CFAO [computer aided design and manufacturing] system will be regrouped at La Garenne around the powerful system already installed and being expanded. The CAD [computer added design] apparatus is centered on an APU 32 computer from Computervision to which are hooked up: on one hand, a cluster of standard peripherals (Phylec, Gixi), and on the other, two secondary SPUG computers to which are connected, in particular, Instaview color graphics stations. For systems geometry calculations, the Center also have a VAX 11-780. In addition the styling center makes use of a very big Amdhal computer set up in the Neuilly facility, and of software programs developed by Computervision or modified by PSA. Systems analysis, in particular, is done through a software program developed by PSA, "Magus." This is where specialized programs designed to work on single stations can be expected. For carrying out tests, the group is planning to computerize the site with a 32 bit computer, whereas a PDP 11 is used at the moment.

The expansion of the group's CAD capabilities will require screens providing better performances for size, resolution and color. The research center already has a wide range of equipment, from the Phylec small screen used by the engineers themselves to the Tektronix 4016 intelligent terminals.

Development will follow that of the capabilities presented by the work stations. For instance, the Instaview graphics terminal which shows graphics with color shadings does not, on the other hand, allow point definition, while the Tektronix 4016 allows a very high line resolution, which is very valuable for making measurements through point definition.

As for the Gixi 516-line color graphics screen, it does not allow a high point definition but only a definition for identification.

As far as software is concerned, the group is using at the moment geometrical CAD programs as well as matrix analysis programs. Studies are in progress to provide elementary volume units so as to create directly an object or a group of objects. The equipment now on the market cannot be easily integrated into a single system that would allow passage from volume to surface, or to a face (for machining), or to an edge and an apex (for representing and adding specifications to the drawing of a part). The PSA group is therefore working on this integration, particularly in the area of volumes limited by curves and complex surfaces.

On a broader aspect, in a more distant future, PSA is planning to interconnect all the group's data bases; storing, transmitting and viewing of drawings and documents will then be directly possible on the CFAO terminal of all geographical locations. At the moment there are 36 such locations (soon 38), encompassing 110 graphics work stations. To visualize the volume of data involved, one must know that the synthesis of a new vehicle is achieved by using the knowledge acquired through previous experiences and by applying current knowledge. Today the data bank provides 400 fundamental parameters for 150 types of vehicles from the PSA group and from national and foreign competitors, amounting to 1,400 variations.

12260

CSO: 3698/206

FACTORY AUTOMATION

BRIEFS

EYES FOR MACHINE TOOLS--Tomorrow's machine tools will be working without any human presence and will be able to be self-correcting, provided that reliable sensors are available and that signal-processing programs are developed to send the data directly into the digital control system of the machine. A first step in this direction has just been taken at the Machine Tool Study and Research Center (Cermo) which is working on optical measurement of the wear and breakage of tools. The first tests started last September. The equipment that was developed uses an electronic CID (Couple Injected Device) movie camera which provides an optical resolution double that given by a CCD [Change coupled device] camera and is not affected by overlighting. The object is to check the edge of a lathe cutter outside of the cutting area: the tool rotor, seen from above, is then compared to the memorized contour of the brand new tool; this allows detection of nicks and cracks in the plates. [Text] [Paris L'USINE NOUVELLE in French 8 Dec 83 p 9] 12260

CSO: 3698/206

SCIENTIFIC AND INDUSTRIAL POLICY

ORGANIZATION, FUNDING OF R&D IN SWITZERLAND

Bern TECHNISCHE RUNDSCHAU in German 13 Sep 83 p 7

[Interview with Emanuel Mooser, director of the Institute of Applied Physics at the Swiss Technical University in Lausanne and vice-president of the National Fund, by Marina de Senarclens: "Field of Tension: Science-Research-Economy"; date and place not given]

[Excerpts] No one disputes that research and development are vitally important to our country. When, however, it is a matter of allocating the funds needed for efficient research both from the state and from the private sector, then reaching a decision is slow and difficult.

We had the opportunity to speak with Professor /Emanuel Mooser/ [in boldface], director of the ETH [Swiss Technical University] in Lausanne and vice-president of the National Fund, about his personal opinion on the field of tension "Science-Research-Economy."

The conversation was led by /Marina de Senarclens/ [in boldface].

[Question] Professor, can you tell us, in your capacity as a member of the Research Council of the National Fund, how research policy in Switzerland is organized and how it supports the economy in the development of new products and processes?

[Answer] The first thing to mention is the Swiss Science Council as the Federal Council's advisory body for questions of science and education policy. Then, the Federal Bureau for Education and Science as the Federal Council's executive body in these matters. The Swiss Education Council is the supervisory body of the two ETH's, that is of Switzerland's largest research organization. Along with the eight cantonal universities, the Federal Government's research institutes could also be mentioned, such as those of the PTT [Post, Telephone and Telegraph Service], the SBB [Swiss Federal Railways], the EMD [Swiss Military Department], etc.

Of important significance for industry is the Commission for the Advancement of Scientific Research (KWF), which promotes projects of application-oriented content, such as the "impulse programs."

The National Energy Research Fund (NEFF) is an important foundation of the Swiss energy economy, which promotes energy-related research projects. The four academies (medical sciences, technical sciences, Natural Science Research Society, Humanities Society) can also be mentioned here and--last but not least--the Swiss National Fund. This is a foundation and promotes research projects primarily at universities. With the considerable extent of its funds and the flexibility it has maintained, it has become "the most important single factor in Swiss research policy"--at least, this is the formulation the central office used in describing the National Fund....

[Question] And what efforts are being undertaken by the National Fund to develop practically oriented research?

[Answer] In this context, one must mention above all the natural science-technical oriented "National Research Programs (NFP's)" of Department IV (see the organizational diagram of the National Fund) and the promotion of the engineering sciences by Department II. Like the KWF of the Federal Bureau for Questions of Economic Activity and--wherever possible--in coordination with it, the NFP's promote common projects of industry and university. The joint responsibility of the projects receives, in the process, a special importance, because it most considerably facilitates the sought after university-industry transfer of technology.

Along with its primary task, the advancement of basic research, Department II for Exact and Natural Sciences today supports above all:

- information-theory engineering
- micro- and opto-electronics
- material sciences and
- biomedical technology.

Nevertheless, one cannot expect wonders of this promotion, since the 10-percent reduction in its budget effected in the Federal Government's economy program has sharply clipped the National Fund's wings.

One can ascertain that, since 1980, the budget restrictions have led to a real decline in the National Fund's accomplishments. That means a severe cut as well in the practically oriented activities of our universities, which until now operated on two levels:

- the operative level for the transfer of concrete results to Swiss concerns, from which chiefly middle-sized and smaller concerns profit, which cannot afford their own, large research efforts, and

- the strategic level for development and maintenance of a technical-scientific potential in areas that are of importance for Swiss industry today and in the future.

The financial situation forces Department II to give priority to the strategic aspects.

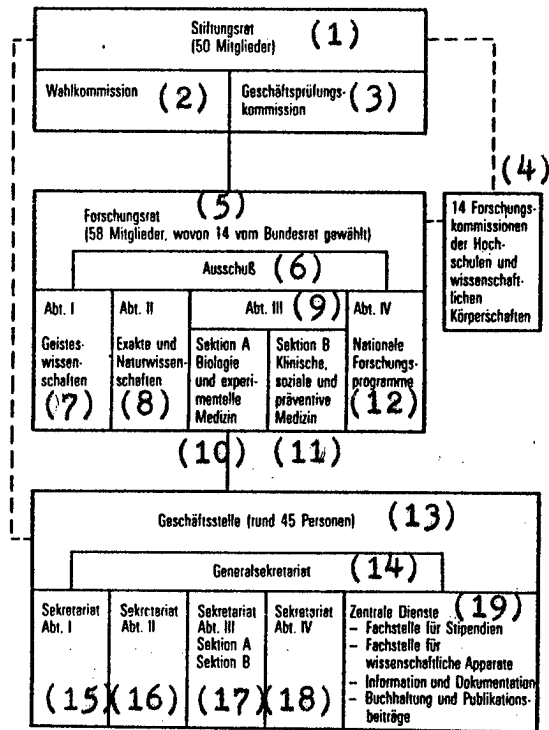

Key:

1. Board of Trustees
2. Election Commission
3. Audit Commission
4. 14 research commissions of the universities and scientific bodies
5. Research Council (58 members, of which 14 are elected from the Federal Council)
6. Committee
7. Department I: Humanities
8. Department II: Exact and Natural Sciences
9. Department III
10. Section A: Biology and Experimental Medicine
11. Section B: Clinical, Social and Preventative Medicine
12. Department IV: National Research Programs
13. Office (about 45 people)
14. General Secretariat
15. Secretariat, Department I
16. Secretariat, Department II
17. Secretariat, Department III, Section A, Section B
18. Secretariat, Department IV
19. Central Services
 - Stipend Section
 - Scientific Equipment Section
 - Information and Documentation
 - Bookkeeping and Contributions to Publications

[Question] What concrete cases can you mention?

[Answer] Von Roll and Sulzer, for example, have been working with several universities for 6 years on the development of new steels with a longer life span. Various firms are cooperating in the currently-running national research program "micro- and opto-electronics," a program, then, that is supposed to help strengthen and improve the competitiveness of the Swiss machine, equipment and watch industry; and this in a technological field that--viewed worldwide--is in rapid expansion.

Lastly, it should be mentioned that Department II examines all the research projects submitted to it for results promising innovation and convertible into practice, and--where there is a prospect of successful collaboration--it helps in establishing contact. In this manner, for example, the transfer of the method of producing superconductive wires in industry was realized.

[Question] Can you cite us some comparative figures on foreign research expenditure? According to /Frederic Vester/ [in boldface], in the United States more than \$50 billion was spent in 1979 on circa 600,000 high-paid scientists and in the Federal Republic of Germany over \$30 billion on 100,000 scientists. /Vester/ [in boldface] believes that this expenditure serves chiefly to maintain an "almost autonomous science industry," which is excessive.

Origin of Funds for R&D Carried Out in Switzerland (1980)

<u>Source of funding</u>	<u>Millions of francs</u>	<u>Total</u>	<u>Percent</u>
Private sector:			
Swiss industry	2771		
Less contributions of public funds	- 14		
	<u>2757</u>		
Consulting engineering companies	4		
Research laboratories of foreign parent firms	75	2836	75
State:			
Research by Federal departments, annex institutes of the ETH's	310		
Research contracts to the private sector	92		
Federal Government and cantons for university research	<u>532</u>	<u>934</u>	<u>25</u>
Total		3770	100

From "Research and Development in the Swiss Private Sector, Report of the Fourth Survey of the Central Office." 1981.

[Answer] Things are entirely different in our country: Altogether, circa 75 percent of the research and development expenditure is carried by the private sector and only 25 percent by public funds. In 1980, the private sector in our country financed 2,836,000,000 francs (about \$1.4 billion) and the state 934 million francs (\$450 million). In all, then, some \$1.85 billion,

which looks, of course, pretty slim alongside the FRG's 30 billion. And in spite of this, Switzerland had, according to a study of the central office on research and development in Swiss private industry in 1980, the highest per capita research expenditure in an international comparison. Figures are thus to be viewed with caution.

Since, at the latest, the Federal Government's hiring freeze in 1974, which was later implemented by most of the cantons, one can no longer speak of a "bloated state research apparatus." Research at our universities is being limited more and more by this; indeed, in some fields, its very existence is threatened. In addition, for 2 years there have been fewer and fewer people who are paid for research by the National Fund. For, under the pressure of economy measures, it has had to give up 200 positions for young academics. It is easy to foresee that we will already be missing these potential researchers in the next 5 years...!

12507

CSO: 3698/211

SCIENTIFIC AND INDUSTRIAL POLICY

FRANCE'S '84 RESEARCH BUDGET INADEQUATE FOR PROGRAMMED GOALS

Paris LE MONDE in French 16 Nov 83 p 16

[Article by Maurice Arvonny: "In 1984, Research Will Not Have the Priority Given by the Planning Law"; for related information, see JPRS WEST EUROPE REPORT, SCIENCE AND TECHNOLOGY No 163 JPRS 84722]

[Text] Research allocations in the 1984 budget were discussed by the Chamber of Deputies this evening Tuesday 15 November; the allocations have been increased 15.5 percent over 1983, a clearly privileged status when compared to other government expenditures generally (LE MONDE of 1 October). Research will get Fr 37.56 billion in 1984. This sum breaks down into Fr 16.88 billion for ordinary expenses, Fr 19.93 billion in planning authorizations, and Fr 0.75 billion in tax credits (instead of Fr 15.22 billion for ordinary expenses and Fr 17.31 billion in planning authorizations, for a total of Fr 32.53 billion in 1983).

Public research employees will increase generally from 59,841 to 60,746. This means the creation of 905 jobs, while the general rule for the national budget is no increase in the number of jobs. However, several factors exist that take the edge off this favorable impression.

Not 18 months ago, parliament passed an orientation and planning law for technological research and development in France. In order to meet the goal of a national research and development expenditure of 2.5 percent of the gross domestic product (GDP) in 1985, annual increases were planned of 17.8 percent in funds--after inflation--and of 4.5 percent in personnel. The credits are way off: 17.8 percent in volume means 25.6 percent in value, and the increase is only 15.5 percent. The increase in ordinary expenses, which are made up mainly of salaries and equipment, is mostly unaffected by policy decisions; rather, the increase in planning authorizations has been slowed down. To comply with the law, these increases should have come to nearly Fr 24 billion instead of the Fr 19.9 billion actually budgeted.

The figure for personnel is also far off target. The 905 jobs created reflect an increase of only 1.5 percent. Also, 195 of these positions incorporate into research organizations agents already working and paid out of other funds. But research needs new blood. The net 334 positions created for researchers will not make up for the aging of 17,528 researchers on the 1983 civilian research budget, especially since departures are few and mobility remains slight.

As noted by Mr Michel Carzart, a Socialist deputy from Paris and special reporter for research, the planning law's orientations were calculated according to a hypothetical annual GDP growth of 3.3 percent. Over the 3-year period of 1982-84, the average annual increase will probably come to less than 1 percent. The GDP share devoted to research had long been stable at around 1.8 percent; it grew slowly in 1979 and 1980 and then more rapidly after 1981, but it will probably reach only 2.15 percent in 1983. As the 1984 budget is not apt to accelerate this increase, it may be doubted that 2.5 percent will be achieved in 1985.

As for research done by business, the increases noted are less than hoped for. The creation of a research tax credit--a tax reduction on the income or on taxes at a rate of 25 percent of the annual increase in research effort--should encourage businesses to provide more for their future. But this is only a hope, and it will take several years to find out whether the Fr 750 million included in the budget as the provisional cost of this measure will have really had the expected multiplier effect.

A final question: is the budget considered by parliament the real budget? Will the minister of Finance again next year continue to block the expenditure of some funds and cancel others outright by a procedure mistakenly called "regulation" (Fr 1.6 billion authorized for the program in 1982 and Fr 1.8 billion in 1983)? This practice is particularly harmful to long-term activity, where decisions are made long before the effects can be known. There should be some certainty about this point if we are to know whether research, which already has a budget growing more slowly than expected, is still a priority item for government action.

8782

CSO: 3698/237

SCIENTIFIC AND INDUSTRIAL POLICY

FINANCIAL STATUS, STRATEGY OF FRANCE'S MATRA

Paris L'USINE NOUVELLE in French 8 Dec 83 pp 42-43

[Article by Claude Amalric: "Matra: Return to the Sources"]

[Text] The pivot of the structural changes underway at Matra is indeed information science, the key to high tech. One exception, however: the automobile, which goes on....

Renewed emphasis on defense, space and electronic components: By specifying these two main lines, the master plan contract made by Matra with the government in the last few days caused surprise.

The first provision was certainly foreseeable. The parent company, mainstay of the group, obtains the major part of its income from it. In 1982, 73 percent of the Fr 5.6 billion turnover of the Matra Company was from its military department, the basis of its fortune. In fact, with about one-fourth of the 28,000 employees of the group, this activity maintains financially the deficit operation of the civilian departments, for a total turnover of 9 billion last year.

Protected by this rampart, Jean-Luc Lagardere is able to face the growth crisis which Matra is undergoing. The second main line (components) will therefore be the object of a considerable stake: Up to 1987, an investment of Fr 950 million is planned in this area, to which 700 million will be added for research and development!

Neither the participating loans granted within the scope of the plan (Fr 300 million for 1983 and 150 million for 1984) nor the Fr 686 million of capitalization increase granted in 1982 to make this ambitious program real, will be too much. All the more so since Matra wants to participate to the fullest in all aspects of the expected information science explosion: industrial through Sormel's robotics, terminals and office machines with Temat and Picart-Lebas (which is expected to come out of the red in 1984), not to mention the microcomputers with which Matra hopes to contact the general public directly (one of Jean-Luc Lagardere's concerns which he has never denied).

The method in this last case is to team up with an industrialist who has shown his ability in this area. "it is the best way to make up for lost time and to learn the business" is the word at Matra, which has already done this several

times (for instance with Tandy, whose TRS-3 and 4 have been manufactured for the past year in the converted Jaz plant at Colmar). Taking advantage of fallout and components from the other units, the "information science" department of the group may well give birth to the first French "portable" 2 years from now. Everything is falling into place to make this possible.

Besides the activities which Jean-Luc Lagardere himself describes as the "group of the future" (of which Datavision is a symbol, in spite of its 80 employees, because of its CFAO [computer-assisted design and manufacturing] system already purchased by Volkswagen, and its key position in the restructuring of the group), apparently less necessary sectors persist, such as automobile and watchmaking.

The fierceness with which Matra's president refuses to abandon these very tight spots is explained by his conviction that despite today's contrary winds, money can be made there someday. Restructured following considerable losses, the "automobile" department has left PSA Peugeot, Inc] to team up with Renault, which is considered to be more dynamic. The first result: next summer will see the birth of a leisure vehicle (a "van" based on the small Traffic van) for which Matra has good expectations.

Watchmaking... An impossible mission so far as the watch movement is concerned. Only one possibility remains: imports. Thence comes the agreement with Seiko, which supplies the electronic portion, Matra for once being satisfied to produce only the cases. The department's losses: 21 million in 1982.

Of the 23 subsidiaries and participating holdings which make up the Matra group, 16 were in the red in 1982. Peritel was broken up, CIMT [Industrial Company of Transportation Equipment] sold, Manurhin split up (the military portion is profitable), Datavision pushed forward "to become one of the five world leaders in CFAO." Matra remains calm. Its forecasts for 1983 permit this. According to its managers, the end of the tunnel is in sight, with almost all of its subsidiaries in balance a year from now.

Renewed emphasis, to be sure. But no blatant giving up. "We have been reproached a lot for being so diversified. You will see that now we shall be criticized in reverse," philosophically remarks Philippe Chassagny, son of Matra's founder.

[Boxed insert, signed by Ph.D.: "Railways: Matra Goes in Reverse"]

Matra is giving up its 43 percent participation in CIMT Lorraine to Alsthom-Atlantique, which henceforth holds the entire capital of the firm. Beyond the financial side, the operation raises two questions: What will be the consequences for Matra in urban transportation? What is the significance of Matra's disengagement from a sector which stands to go through 2 difficult years?

For Matra this withdrawal from CIMT (1,200 employees, turnover of FR 540 million) in no way means abandonment of the railways business. At most it means the concentration of its efforts on the finer part, the automatic components

and information science which are the specialty of VAL [expansion not known].

It remains nevertheless true that French railway construction is in trouble. In a short time Soule (freight cars, bogies) of Bagnères-de-Bigorre, and then CFAS, subsidiary of Usinor, have announced draconian restructuring plans. There is no doubt whatsoever that CIMT Lorraine, which lost Fr 96 million in 1982 and has not seen its situation improve in 1983, will have to go through the same. Here is a perspective which explains Matra's prudent going in reverse.

5586

CSO: 3698/204

SCIENTIFIC AND INDUSTRIAL POLICY

BRIEFS

NEW PHILIPS RESEARCH PLAN--Eindhoven, December 8--Philips has signed an agreement with the French concerns Compagnie Generale d'Electricite and Thomson-Brandt for joint research in the field of radio beam transmission, a spokesman for the Dutch electronics company said today. The state-owned French companies will work with Philips' French subsidiary Telecommunications Radioelectriques et Telephoniques (TRT), the spokesman said. The TRT subsidiary handles all the Dutch multinational's activities in the field of radio beam transmission. This area was not covered by an agreement made with America's AT&T earlier this year under which most of Philips' telecommunications activities were transferred to a new joint venture company. [Text] [The Hague ANP NEWS BULLETIN in English 9 Dec 83 p 5]

FOUR ITALIAN RESEARCH PROGRAMS--Rome--The Italian government set forth on 22 December the objectives of four national research programs approved by the Interministerial Committee for the Coordination of Industrial Policy (CIPI) in chemistry, microelectronics, steelmaking, and biomedical technology. According to the text in the official journal, these programs will receive research contracts for more than 400 billion lire (Fr 2 billion). These contracts are to lead to "the development of strategic and highly innovative technologies capable of having industrial applications in the medium term." Private firms may participate in these programs individually, jointly among themselves or with public bodies. Private firms have 90 days in which to submit proposals to the ministry of Scientific Research. The four programs are as follows: Chemistry (183.6 billion lire): pharmacological chemistry, agricultural chemistry, synthetic chemistry (components for perfumes, etc.), coal and oil chemistry. Microelectronics: (104.3 billion lire): VLSI [expansion unknown] and semiconductor components. Steel (85.2 billion lire): strategic products and structural innovations in steel-making processes. Biomedicine (29.8 billion lire): diagnostic techniques and artificial organs. [Text] [Paris AFP SCIENCES in French 29 Dec 83 p 8 bis] 8782

CSO: 3698/237

TECHNOLOGY TRANSFER

MAIL DROPS IN ZUG IN SEARCH OF THEIR OWNERS

Zurich DIE WELTWOCHEN in German 8 Dec 83 No 49 p 13

[Article by Wolfgang Winter]

[Text] Chief Public Prosecutor Boettcher at the law court in Luebeck would be happy if noted Swiss daily newspapers were right in saying that the German businessman Richard Mueller, the "director" of two mail-drop firms in Switzerland, really was in custody and had to look forward to his sentencing. On the contrary, however, people in this northern German Hanseatic city have scarcely more than an inkling of Mueller's whereabouts. In Seevetal, a district of the small town of Jesteburg within the Northern Heath southwest of Hamburg where Mueller had registered from Lucerne a good 5 years ago--in fact with Swiss identification papers!--he cannot be found, of course. This man, who is charged with the recently uncovered smuggling of sophisticated electronic materials from Digital Equipment Corporation, Maynard/Massachusetts, by way of South Africa and Sweden and with the Soviet Union as their destination, most likely has made off to Hungary, one of the six countries around the globe where he has a residence.

"Operation Exodus"

It is also possible that he sought refuge directly under the wing of the Soviet secret service, the KGB, although he had been able to avoid for a short time the inclusion of his name in the "black list" of the Americans. This document publicly exposes persons and firms which have violated the inner-NATO ban on strategic exports into East Bloc states, and it is constantly substantiated and updated in the "Coordinating Committee for East-West Trade" ("Cocom").

Since the autumn of 1981, when the American customs authorities began a special undertaking called "Operation Exodus" for the exposure of this very specialized supermarket, the "black list" has grown even more rapidly than the list of the banned electronics equipment, and that is saying a great deal. Since then about 1,400 shipments have gotten caught in the nets of this organization. Nevertheless, it is still assumed that there is a high percentage of undetected crimes. Now on the list are, for example, both the California optics manufacturer Walter Spawr and the German computer dealer Werner J. Bruchhausen, both of whom made use of Swiss forwarding

addresses and specific Swiss forwarding services for their business with the East, in part by way of Bulgaria. Also reflected in this list, of course, was the case last year of the Neuenburg company Favag SA, where extremely valuable computer material was intended to be diverted to Moscow via Geneva and Paris. And WELTWOCHER readers recall an analogous course of events, likewise in 1982, when the Kreuzling firm of Elmont AG and Semitec AG in Zug were commissioned to bring microchips from Arizona in the United States via Toronto and the FRG into the Soviet Union (WELTWOCHER of 18 August 1982).

In the Zug Commercial Register, Semitec is the neighbor of Semitronic AG, which together with Integrated Time AG--which is registered in Malter of Lucerne--was involved in the most recent coup of this sort associated with the name of Richard Mueller. These two firms appear on the shipping documents of the total of seven transcontainers, with the Soviet Union as their final destination, which were seized recently in the ports of Hamburg and Helsingborg and unloaded from the South African freighter "Elgaren." And not only on these documents: As a part of the same order, other electronics parcels from the United States arrived at Stockholm by air and at Malmoe by rail. It is an instructive example of how the intended purpose is usually concealed in this business. Even in the eyes of experts, that which was found in the containers of altogether seven ships was entirely and even more properly suited for civilian use. Only the totality of hardware and software from the various transport routes revealed that what was in transit here were veritable missile guidance systems of the highest electronic quality.

Directors are Missing

The reason why states such as Switzerland or Sweden are preferred as way stations for such hot goods becomes clear from their status of independence from NATO decisions, and in the case of Switzerland also from the extremely easy establishment of mail-drop firms, which in practice requires only 50,000 francs and a single director with a Swiss passport. But it is unexpectedly hard to find out who in Zug and Malter besides the fugitive "director" has the responsibility to bear. In the Lucerne city, the Kuesnacht businessman Robert Reinhard had taken over as director from the Zug trustee Juerg Schoch a few months ago, but now he too is said to have relinquished his office again. And an altogether confusing situation is presented by Zug's Semitronic, whose board of directors, according to the Register of Commercial Companies, is made up solely of a certain Juerg Keller. The businessman of this name, whom the official "Index of Directors" (Orell Fuessli Information Documents) associates with Semitronic even for 1984, denies most emphatically that he has anything to do with this. The Obfeld metal trader, the head of the local firm of Jakob Keller Steel AG, is apparently not the managing director of the Zurich car dealership of J. H. Keller AG either, although the information document still gives him this title. But all the other directors having this name likewise declare that at most they learned of a company called Semitronic through recent press reports.

Fear of Retaliation

For the Luebeck public prosecutor's office, Richard Mueller (41), born in Hamburg, is all the more clearly identified, since it was against him that it instituted preliminary proceedings just "a few months" ago, although at that time it was "because of a bankruptcy affair" (chief prosecutor Boettcher). Provided that he can be apprehended at all, the problem of how he is to be threatened now with imprisonment of up to 3 years or a fine-- inasmuch as he has really not put in at any NATO state with the presently confiscated containers--evidently is solved by the German foreign-trade law along with the relevant ordinance. According to these, FRG citizens need a special permit if they want to deal in a commodity which prejudices the security of the country, the "peaceful social life of the people," or the foreign relations of Bonn, even if such "embargo goods" never physically pass through the FRG.

And the Swiss accomplices? At least the mail-drop mischief will have to be brought under control in the near future, perhaps through a manifold increase in the minimum capital needed. This will be done either from understanding or fear: Fear of the threat already being heard from the Americans, to put certain shackles on technology transfer in the future with respect to Switzerland also.

12114

CSO: 8020/0533-A

TECHNOLOGY TRANSFER

FRANCE SELLS USSR FLEXIBLE WORKSHOP WITH UNIMATE ROBOTS

Paris INDUSTRIES ET TECHNIQUES in French 1 Nov 83 p 28

[Article by I.G.: "For the USSR: Two Robotized Car-Body Assembly Lines"]

[Text] Each line can assemble four types of body-shells. Eighteen robots make over 600 spot welds. Something new in the East...

It is now the turn of the Soviet automobile industry to get interested in flexible production workshops. Especially to assemble the car body of the Lada No 2 (a future model) at the VAZ plant in Togliattigrad. The Soviet Avto Pro Import has placed an order with the French company Sciaky for the manufacturing and on-site installation of nine large welding transfer lines. The two final body-car assembly lines covered by this huge contract are remarkable by their high degree of flexibility. Indeed, each will use 18 Unimate robots. Something new for the automobile industry in the East.

32.5 Cars Per Hour

Each of the two lines will be designed to assemble four types of body shells in any order: two models with three or five doors and with right-hand or left-hand drive. At an effective rate of 500 vehicles per 15-hour workday, this represents 32.5 cars per hour; at the various conforming stations, the robots carry out both the temporary welding designed to ensure rigidity and the finish welds. A total of over 600 spot welds are made automatically on each body shell.

The Sciaky Company (Vitry-sur-Seine) is now completing the assembly and final adjustment of the first final assembly line to be delivered to the VAZ plant by the end of 1983. The Vitry-sur-Seine workshop has manufactured many robotized welding lines, but this is the first time it has to take delivery of all the robots. For an actual "dummy run."

The 355-ton line is 70 m long and 10 m wide; it consists of 13 stations connected through a bar transfer line with a pitch of 5.5 m. The loading of the components --the pre-welded body shell and the body ceiling--and the unloading of the finished car body are fully automated. Among the main stations, we should mention the conforming station for the pre-welded body shell, consisting of the underbody and side panels. This is a four-column high-rigidity press equipped with internal

conforming tools and two interlocking tool sets on the sides. At this station, 6 robots (4 on the sides and 2 hanging at the front and back) then make 166 spot welds. Finally, after the body shell has gone through two more stations--floor conforming and welding--using four robots and two programmable axes (Sciaky-designed modular components), the body ceiling (roof) is added. The body ceiling is then conformed to the body shell, and the floor is worked on again for the last time. These two operations involve over 250 welds.

The transfer line is actuated by an electromechanical unit: a geared motor associated to a crank-connecting rod. The motor provides a sinusoidal-linkage feed movement. The feed and return movements are provided by a pneumatic clutch-brake. This final assembly line is controlled by three Sciaky SY minicomputers. These central processing units pilot the transfer and tool movements depending on the body-shell type. But they also control the robots while they program and follow their approach paths. The computers also take into account the very work of the resistance-welding tongs (at the end of the robot arm). Each station keeps track of what type of body shell is going through. This is done through mechanical tracers. All the operators have to do is to supervise the facilities through video screens and communication consoles staggered along the line.

At a second level, the company supplies production management and follow-up systems linked to several assembly lines. With such a robotized line, it is possible to assemble other types of body shells, for instance the station-wagon version. This, of course, requires setting up new conforming tools. However, two free stations integrated along the line will make it possible to insert additional conforming stations and, therefore, authorize the assembly of future models without having to stop the line.

9294

CSO: 3698/227

TECHNOLOGY TRANSFER

BRIEFS

USSR IMPORTS CHEMICAL EQUIPMENT--In the opinion of the Eastern Market Research Institute in Hamburg, the large imports of chemical apparatus from the FRG by the USSR will not continue in the 1980's. The reason is not to be sought in a greater capacity of the Soviets to construct chemical apparatus but in the fact that many of the capacities built up in the USSR in the last 10 years with foreign help are not being fully used. Thus in 1978, an acrylnitril plant with an annual capacity of 150,000 tons went into operation in Saratov, a plant whose capacity is used to only a small extent--currently 30 percent. The average utilization of capacity in the petrochemical industry is now said to be about 60 percent. Initially, therefore, the USSR wants to utilize fully existing capacities and apply available investment resources to the completion of installations now under construction. New chemical projects that would lead to the importation of equipment are not expected until after 1990. [Text] [Duesseldorf EUROPA CHEMIE in German 14 Nov 83 p 582] 9746

FRENCH ENGINEER ACCUSED OF ESPIONAGE--Paris--A French engineer, Pierre Bourdiol, 56, who had worked on the Ariane program in particular, and who is accused of having been in contact with Soviet agents since 1970, was indicted on 30 November and was committed to the Fresnes prison (Val de Marne). Employed since 1969 by the Thomson-CST [Thomson-General Wireless Company], he was placed on detached service by that company from 1974 to 1979 to work at the SNIAS [National Industrial Aerospace Company] at Mureaux (Yveline) on space programs and especially on the Ariane rocket. Pierre Bourdiol, who, it has been learned from reliable sources, acted in response to his ideological convictions, was in a position to provide the USSR with information on the leading-edge technologies being used in this sector. The DST's [Directorate of Territorial Surveillance] investigation is seeking now to determine if he had any accomplices at the SNIAS. [Text] [Paris AFP Sciences in French 8 Dec 83 p 39] 9238

USSR BUYS SWISS BIOTECH EQUIPMENT--Hoffmann-La Roche received an order from the Soviet foreign trade organization Medexport for the shipment of biochemical compounds for microbiological and immunological research and of raw materials for the pharmaceutical industry. The shipment is to take place before the end of this year; nothing is known of the value of the order. Also shipping raw materials and compounds for biochemical and microbiological research in 1983 are the two Swiss firms Calbiochem AG and Merz and Dade Pharma. Here, too, the customer is Medexport. [Text] [Solothrun CHEMISCHE RUNDSCHAU in German 5 Oct 83 p 15] 9746

END