

JPRS-JST-91-021
1 JULY 1991



JPRS Report

19990107 097

Science & Technology

Japan

RESEARCH ON GENE ORGANIZATION

DTIC QUALITY INSPECTED 3

REPRODUCED BY
U.S. DEPARTMENT OF COMMERCE
NATIONAL TECHNICAL INFORMATION SERVICE
SPRINGFIELD, VA. 22161

JPRS-JST-91-021
1 JULY 1991

SCIENCE & TECHNOLOGY
JAPAN

RESEARCH ON GENE ORGANIZATION

906C0070 Tokyo RIKAGAKU KENKYUJO PUROJEKUTO HOKOKUSHO in Japanese 1 Jul 89
pp 1-89

[1988 Project of the Institute of Physical and Chemical Research: "Research on Gene Organization." Published by the Institute of Physical and Chemical Research, Division of Life Science Advancement]

CONTENTS

Committees.....	1
Preface.....	2
I. Outline of Research Program	
1. Research Object.....	2
2. Research Items and Research Targets.....	2
3. Yearly Research Program (Table 1).....	3
4. Organizations for Research Advancement (Figure 1).....	3
5. Status of Execution of Research (Table 2).....	3
6. Meetings of Committee.....	3
II. Particulars	
1. Improvement and Development of Sequencing Systems.....	10
1) Development of DNA Purification and Extraction Apparatuses.	10
2) Development of Sample Injection Apparatuses.....	14

3) Improvement and Development of a New Electrophoresis Apparatus.....	22
4) Development of Software for Editing Base Sequences.....	28
5) Development of Gel Preparation Apparatus and System Controller.....	32
6) Development of Fundamental Techniques for Sequencing Systems.....	33
2. Maintenance of Genetic Materials and Analytical Techniques....	36
1) Preparation of Genetic Materials.....	36
(1) Development of Material Preparation Method.....	36
(1) Collection of hybrid cells containing human chromosomes and construction of human chromosome panel.....	36
(2) Separation of chromosomes by sorting and construction of genomic libraries.....	38
(3) Construction of giant DNA libraries and selection of DNA clones using yeast artificial chromosome vectors...	40
(2) Development of Ordering Techniques.....	42
(1) Developing of handling techniques for giant DNA clones.	42
(2) Development of ordering techniques for cosmid clone....	45
2) Development of Mapping Techniques.....	47
(1) Physical Mapping With DNA Probes.....	47
(2) Physical Mapping Using Linking Libraries.....	49
(3) Development and Application of New Methods for Detecting DNA Polymorphism.....	50
(4) Chromosome Mapping of DNA Clones by in Situ Hybridization.....	53
(5) Analysis of Transcription Gene (cDNA) and Chromosome Mapping.....	55
3) Collection of Genetic Materials and Information.....	57

Study on Mapping, Sequencing of Human Genome

906C0070 Tokyo RIKAGAKU KENKYUJO PUROJEKUTO HOKOKUSHO in Japanese 1 Jul 89
pp 1-89

[Text] **Committees**

1988

Advisory Committee for the Research on Gene Organization

Chairman: Kenichi Matsubara (Cell Technology Center, Osaka University)

Committee: Yohji Ikawa (Institute of Physical and Chemical Research)
Isao Endo (Institute of Physical and Chemical Research)
Susumu Nishimura (National Cancer Center)
Masami Muramatsu (Faculty of Medicine, University of Tokyo)
Akimitsu Wada (Faculty of Science, University of Tokyo)

Liaison Committee for the Research and Development of Sequencing System

Chairman: Isao Endo (Institute of Physical and Chemical Research)

Committee: Shiyo Eguchi (Mitsui Information and Development Co., Ltd.)
Hideki Kamihara (Institute of Basic Research, Hitachi, Ltd.)
Masamitsu Saito (Seiko Electronics Co., Ltd.)
Shigeuo Suzuki (Tosoh Corporation)
Eiichi Soeda (Institute of Physical and Chemical Research)
Katsuo Nishi (Institute of Physical and Chemical Research)

Liaison Committee for the Research and Development of Genetic Material and Analysis

Chairman: Yohji Ikawa (Institute of Physical and Chemical Research)

Committee: Misao Ohgi (Cancer Research Center of Saitama Prefecture)
Yoshiyuki Sakaki (Laboratory of Genetic Information, Kyushu University)
Nobuyoshi Shimizu (Faculty of Medicine, Keio University)

Eiichi Soeda (Institute of Physical and Chemical Research)
Yasufumi Murakami (Institute of Physical and Chemical
Research)
Kazunari Yokoyama (Institute of Physical and Chemical
Research)

Preface

With the rapid advancement of genetic engineering and analytical techniques, a movement has arisen inside and outside Japan to clone DNA of human chromosomal genes, construct genetic maps (gene mapping), and analyze DNA base sequences (sequencing).

To advance this movement, however, many problems remain to be solved. These include inadequate gene mapping techniques, inadequate preparation techniques for materials used for the sequencing, insufficient accuracy for the sequencing, lack of systematization, etc. The Institute of Physical and Chemical Research started in 1988 a four-year research project on gene organization, referring to the results of the research conducted under the fund for advancing scientific techniques, and to a report, "On a Policy for Advancing the Integrated Research and Development of the Analysis of Human Genes." Subjects of the project are "the research and development of sequencing systems" aiming at the automation of these systems and "the research and development of analytical techniques for genetic materials" aiming at the arrangement of genetic materials for the sequencing.

This report presents the summarized results of the "Research on Gene Organization" project conducted by the Institute of Physical and Chemical Research in 1988.

It must be noted that the advisory committee gave valuable advice during the progress of this research.

Ichiro Inoue, director
Division of Development and Advancement
for the Research on Gene Organization

I. Outline of Research Program

1. Research Object

The analysis of human chromosomal DNA is systematized and the techniques and materials for the analysis are arranged to prepare DNA materials and construct a data base that would provide bases for elucidating human genes.

2. Research Items and Research Targets

1) Development of the system for analyzing base sequences

Automated systems are arranged for rapid and accurate analysis to determine gene base sequences in the level of human chromosomes.

2) Maintenance of genetic materials and analytical techniques for human DNA

Fundamental techniques are developed for analyzing human chromosomal DNA. These include the preparation of chromosomal DNA materials, ordering techniques, and mapping techniques. Systems are also established to collect and store the materials to analyze human chromosomal genes, and also to arrange sequencing data.

3. Yearly Research Program (Table 1)

4. Organization for Research Advancement (Figure)

5. Status of Execution of Research (Table 2)

6. Meetings of Committee

- | | |
|--|---------------|
| 1) Meeting for the sequencing system | (6 Jun 1988) |
| 2) Meeting for the sequencing system | (17 Jun 1988) |
| 3) Meeting for the sequencing system | (7 Sep 1988) |
| 4) Meeting for the sequencing system | (16 Nov 1988) |
| 5) Liaison meeting of directors for research and development of gene organization | (27 Nov 1988) |
| 6) Meeting of advancement division for research and development of gene organization | (27 Dec 1988) |
| 7) Meeting of liaison committee for research and development of sequencing system | (11 Jan 1989) |
| 8) Meeting of liaison committee for research and development of genetic materials and analysis | (7 Mar 1989) |
| 9) Meeting of advisory committee for research and development of gene organization | (8 Mar 1989) |

Table 1. Yearly Research Program

Items	Subjects	Contents of research	88	1	2	3
I. Improve- ment and develop- ment of sequenc- ing system	1) Develop- ment of DNA extraction and purification apparatus	1 Development of fundamental technique for DNA extraction and purification apparatus 2 Basic design of apparatus 3 Design for manufacture of apparatus and its manufac- turing 4 Development of injection part of the apparatus 5 Evaluation of the apparatus				
	2) Improve- ment and development of reaction apparatus for sequencing	1 Improvement of existing reaction apparatus for sequencing 2 Evaluation of the apparatus				
	3) Develop- ment of sample injection apparatus	1 Development of fundamental technique 2 Design and manufacture of the apparatus 3 Evaluation of the apparatus				
	4) Improve- ment and development of new elec- trophoresis apparatus	1 Establishment of direct detection technique for fluorescence labeled DNA 2 Development of fundamental technique for advancement of function 3 Partial manufacture, evalu- ation of above apparatus 4 Manufacture, evaluation of high functional apparatus				
	5) Develop- ment of software for editing base sequences	1 Development of software automatically link-editing 100 base pairs per day 2 Evaluation of software				
	6) Develop- ment of gel preparation apparatus	1 Development of fundamental technique 2 Manufacture of prototype of apparatus on trial 3 Improvement and evaluation of apparatus				

[continued]

[Continuation of Table 1]

Items	Subjects	Contents of research	88	1	2	3
I. [contd.]	7) Development of system controller	1 Determination of processing contents, such as monitoring and control of operation state of apparatus, etc., design of system controller 2 Manufacture of interface for system control and development of software 3 Evaluation of system controller				
	8) Development of conveyance apparatus	1 Basic and functional design of apparatus 2 Manufacture of apparatus 3 Comprehensive adjustment and evaluation of apparatus				
	9) Operation test of sequencing system	1 Evaluation of fundamental techniques, such as extraction and purification of DNA, sample injection, etc. 2 Comprehensive evaluation of sequencing system				
II. Maintenance of genetic materials and analytical techniques 1. Preparation of genetic materials 1) Development of preparation method for materials	1) Collection of hybrid cells containing human chromosome panel	1 Investigation of storage condition for hybrid cells and preparation of standard protocol 2 Collection of hybrid cells having human chromosome 21 3 Collection of hybrid cells having other human chromosomes 4 Development of techniques for constructing artificial chromosomes of higher animals				
	2) Separation of chromosomes by sorting and construction of genomic libraries	1 Development of sorting techniques 2 Construction of genomic libraries 3 Examination of genomic libraries				

[continued]

[Continuation of Table 1]

Items	Subjects	Contents of research	88	1	2	3
II.contd 1. contd	3) Construc- tion of giant DNA libraries and selection of DNA clones using yeast artificial vectors	1 Development of techniques for constructing giant DNA libraries 2 Development of selection techniques for giant DNA clones specific to chromo- somes 3 Collection of giant DNA clones specific to chromo- somes				
2)Devel- opment of ordering tech- niques	1) Develop- ment of handling techniques for giant DNA clones	1 Isolation, identification of giant DNA clones from human chromosome hybrid cells 2 Development of ordering techniques for giant DNA clones 3 Development of subcloning techniques for giant DNA clones				
	2) Develop- ment of ordering techniques for cosmid clones	1 Collection of DNA cosmid clones specific to chromo- somes 2 Development of ordering techniques for DNA cosmid clones specific to chromo- somes 3 Examination, evaluation of ordering techniques				
II. 2.Devel- opment of mapping tech- niques	1) Physical mapping with DNA probes	1 Development and evaluation of probe DNA specific to chromosomes 2 Physical mapping with probe DNA specific to chromosomes 3 Improvement, evaluation of physical mapping techniques				
	2) Physical mapping using linking libraries	1 Development of construction methods for linking clone libraries 2 Collection and examination of linking clones 3 Identification of linking fragment size and construc- tion of physical map				

[continued]

[Continuation of Table 1]

Items	Subjects	Content of research	88	1	2	3
II.contd 2.contd	2)contd.	4 Development of isolation techniques for giant DNA 5 Construction of cloned maps by application of separation techniques for giant DNA				
	3 Development and application of new methods for detecting DNA polymorphism	1 Development of new methods for detecting DNA polymorphism 2 Establishment of high resolution techniques for constructing linkage maps using new methods for detecting DNA polymorphism				
	4) Chromosome mapping of DNA clones by in situ hybridization	1 Collection of clones and mapping by highly accurate in situ hybridization 2 Establishment of new highly accurate mapping method 3 Establishment of high-speed mapping by introducing picture analyzing apparatus 4 Establishment of mapping method for giant DNA clones				
	5)Analysis of transcription gene (cDNA) and chromosome mapping	1 Construction of cDNA libraries specific to chromosomes 2 Mapping of cDNA specific to chromosomes on chromosomes				
II. 3.Col- lection of genetic mater- ials and infor- mation	1)Collection and arrangement of genetic materials	1 Establishment of storage techniques and preparation of arrangement files for genetic materials 2 Collection of genetic materials				
	2)Collection and arrangement of sequence data of DNA clones	1 Construction of format for DNA clones classified by individual chromosome 2 Construction of format for human sequencing data base and investigation of collection methods 3 Collection of data for DNA clones and sequencing				

Table 2. Status of Execution of Research

(Unit: ¥1,000)

Items	Research subjects	Research organization Researcher	Funds
I. Improvement and development of sequencing system	1) Development of DNA extraction and purification	Tosoh Corp. Shigeo Suzuki	99,000 15,000
	2) Development of sample injection apparatus	Seiko Electronics Masamitsu Saito	13,000
	3) Improvement and development of new electrophoresis	Hitachi, Ltd. Shinpei Suzuki	33,000
	4) Development of software for editing base sequences	Mitsui Information & Development Co. Shiyo Eguchi	9,000
	5) Development of gel preparation apparatus and system controller	Div. of Basic Research Technology, IPCR, Katsuo Nishi	7,000
	6) Evaluation of fundamental techniques for sequencing system	Laboratory of Gene Bank, IPCR Eiichi Soeda	22,000
II. Maintenance of genetic materials and analytical techniques 1. Preparation of genetic materials 1) Development of preparation method for materials 2) Development of ordering techniques	1) Collection of hybrid cells containing human chromosome and construction of human chromosome panel	Laboratory of Gene Bank, IPCR Yasubumi Murakami	80,000 6,000
	2) Separation of chromosome by sorting and construction of genomic libraries	Research Commission Nobuyoshi Shimizu	7,000
	3) Construction of giant DNA libraries and selection of DNA clones using yeast artificial vectors	Laboratory of Gene Bank, IPCR Eiichi Soeda	8,000
	1) Development of handling techniques for giant DNA clones	Laboratory of Gene Bank, IPCR Kazunari Yokoyama	5,000
	2) Development of ordering techniques for cosmid clone	Research Commission Yuh Honjo	5,000

[Continued]

[Continuation of Table 2]

Items	Research subjects	Research organizations Researchers	Funds
II. [contd] 2. Development of mapping techniques	1) Physical mapping with DNA probes	Research Commission Yoshiyuki Sakaki	6,000
	2) Physical mapping using linking libraries	Research Commission Misao Ohgi	8,000
	3) Development and application of new methods for detecting DNA polymorphism	Research Commission Kenji Hayashi	5,000
	4) Chromosome mapping of DNA clones by in situ hybridization	Research Commission Hiroshi Nakai	5,000
	5) Analysis of transcription gene (cDNA) and chromosome mapping	Research Commission Kazukiyo Onodera	5,000
3. Collection of genetic materials and information	1) Collection and arrangement of genetic materials	Laboratory of Gene Bank, IPCR Yohji Ikawa	10,000
	2) Collection and arrangement of sequence data of DNA clones	Laboratory of Gene Bank, IPCR Yohji Ikawa	10,000

IPCR: Institute of Physical and Chemical Research

II. Particulars

1. Improvement and Development of Sequencing Systems

1) Development of DNA Purification and Extraction Apparatuses

(Name and affiliation) Kazuo Ogawa, Takanori Matsuno, Nami Kawakami, Akihiro Nishi, Kenji Koyama, Motohiro Tsuboi, Tetsuyuki Azuma, Kenji Arichika, Mitsuru Fukamachi, Masawo Suzuki (Scientific Measurement Division, Tosoh Corporation)

(1) Object

The object of this research is to develop DNA extraction and purification apparatuses to provide bases for the elucidation of human genes.

(2) Summary

M13 phages, inserted human genes by shotgun methods, were isolated from culture media of *E. coli* in which the phages had proliferated. Then DNA was

isolated from the M13 phages and purified. Methods were tested to carry out these two procedures continuously by combining MF membranes with UF membranes. In 1988, fundamental techniques were individually investigated, and the selection of two kinds of membrane, the condition of enzyme reactions, and the stability of reagents were almost determined, and basic specifications for the apparatuses were prepared.

(3) Text

(1) Selection of membranes

In the first step of this method, bacterial cells were separated with MF membranes. It is generally believed that *E. coli* can be filtered off with 0.45 μm MF membranes. First, confirming that commercial MF membranes can separate when *E. coli* from culture media containing phages, with the time required for the separation being roughly measured. The results showed that 2 ml of *E. coli*-phage media can be separated within one minute with the 13 mm ϕ membrane, under a pressure of 1 kgf/cm².

In the next step of UF membrane, the selection of membranes that can separate in a short time and with a high recovery rate was required. Actually, however, it is only polysulfone membranes for which many kinds are available, fitting to different fractionation molecular weights. Hydrophobicity slightly remains in this polysulfone membrane, but fortunately no problem is supposed to exist in the recovery aspect because of the hydrophobicity of DNA itself. Then recoveries of M13 DNA obtained by PEG-proteinase K reactions were tried by using three kinds of membranes having fractionation molecular weights of 3 million, 1 million, and 300,000, respectively. The results are shown in Figures 2 through 5. The 300,000 membrane was least leaky for DNA and was used for further experiments because membranes having smaller fractionation molecular weights required a longer time for the separation and completely did not always remove proteinase in the reaction. Also proteinase activities that remained were not detected in the DNA solution concentrated with this membrane by both casein digestion and synthetic substrate methods.

This method developed cannot separate those membranes having close molecular weights, since it separates bacteria, phages, DNA, and culture media, based on the differences between their molecular weights. Another device, therefore, may be necessary for removing lysis DNA derived from *E. coli*. It was said, however, that *E. coli*-M13 phages are generally cultured for four hours and DNA derived from *E. coli* was not observed in such a short period. Even if lysis DNA was contaminated for some reason, only phage DNA could be removed by adding a small amount of DNase in the culture medium.

(2) Investigation on reaction conditions

Enzyme reactions using proteinase K were well known. In this research, however, experiments were carried out from the point of membrane separation. In the first place the reduction of SDS concentrations were investigated, since the membrane separation with high concentrations of SDS requires a long time,

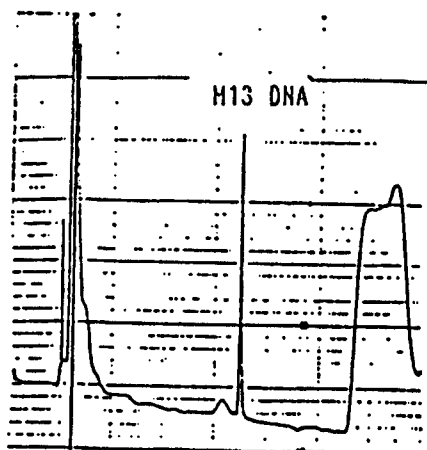

Figure 2. M13 DNA Obtained From PEG-Proteinase K

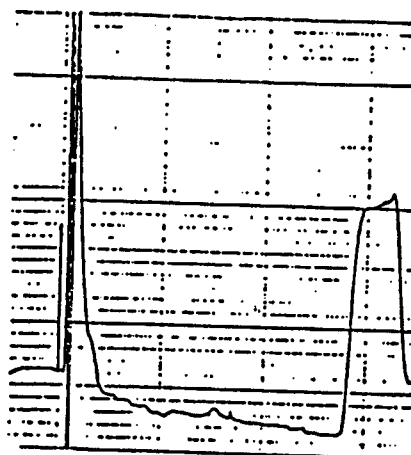

Figure 3. Filtrate Separated From the Sample Shown in Figure 2 With a 300,000 Fractionation Molecular Weight Membrane (300 PS)

Figure 4. Filtrate Separated With a 1 Million Fractionation Molecular Weight Membrane (1,000 PS)

↓

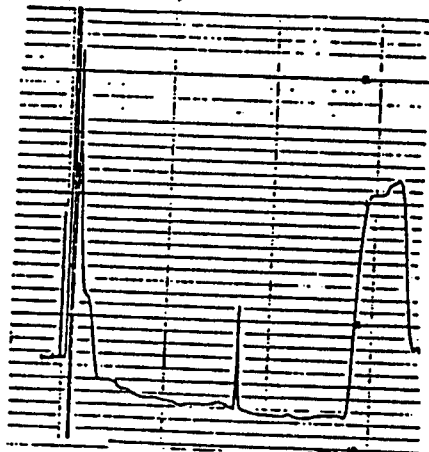
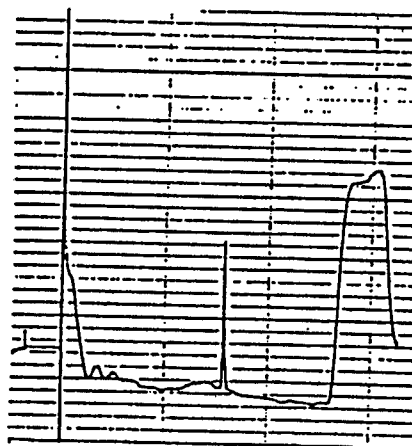

Figure 5. Filtrate Separated With a 3 Million Fractionation Molecular Weight Membrane (300 PS)

↓



Analytical condition for column

Sample	: M13 DNA solution treated with enzyme 100 μ l	Flow rate	: 1 ml/min
Column	: TSKgel DEAE-NPR	Temperature	: 25°C
Column size	: 4.6 mm ID x 3.5 cm	Chart speed	: 5 mm/min
Mobile phase:	A: 20 mM Tris-HCl (pH 8.0) + 0.2 M NaCl	Detector	: UV260 nm
	B: 20 mM Tris-HCl (pH 8.0) + 1.0 M NaCl		
	A (%) 75→30 linear gradient 10 min		

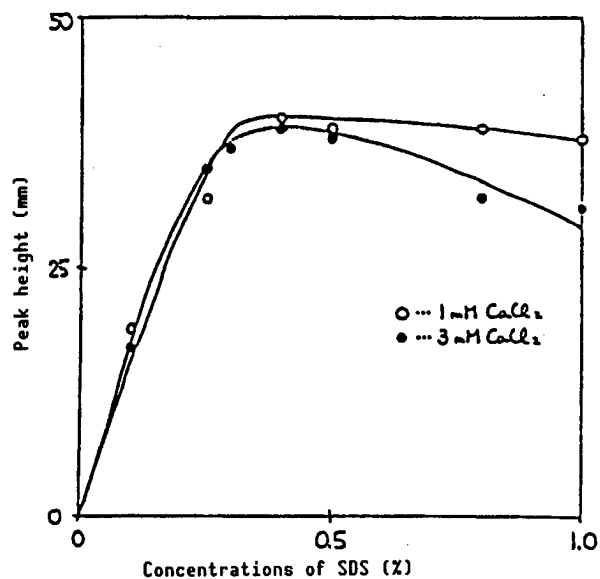

Figure 6. Investigation of SDS Concentration

due to the viscosity of SDS. The result is shown in Figure 6. Also concentrations of enzymes were very reduced in the presence of SDS. The reaction mixture was decided as follows:

To the minute volume of concentrated phages

0.4 percent SDS in TE (pH 8)	500 μ l
5 μ g/ml proteinase K in 1 mmol/l CaCl ₂	200 μ l

This reaction mixture was stable for at least one week and no change was seen when kept at 4°C and room temperature.

Next, when reaction temperatures from 37-50°C were examined, it was found that the reaction would be completed in 10 minutes at 40°C.

(3) The design of the membrane cassette and the basic design of the apparatus

Since the separation with MF membrane can be performed under low pressure, a large membrane area is not required. In the case of UF membrane, however, systems in which culture media were mixed requires a long time for the separation in particular, if the membrane areas were not large enough. In fact, it required about 30 minutes to remove culture media in the case of the 13 mm ϕ (1.33 cm²) diameter. If the diameter was 21 mm ϕ (3.46 cm²), the culture media was removed in 10 minutes. A problem, however, emerged that the recovery of concentrated DNA in the final process became difficult, if the membrane area was large. Therefore, devices to change the shape of the hole are necessary for easy recovery. It is scheduled to design membrane cassettes with elliptical holes and try to use them at a tilted position for the recovery.

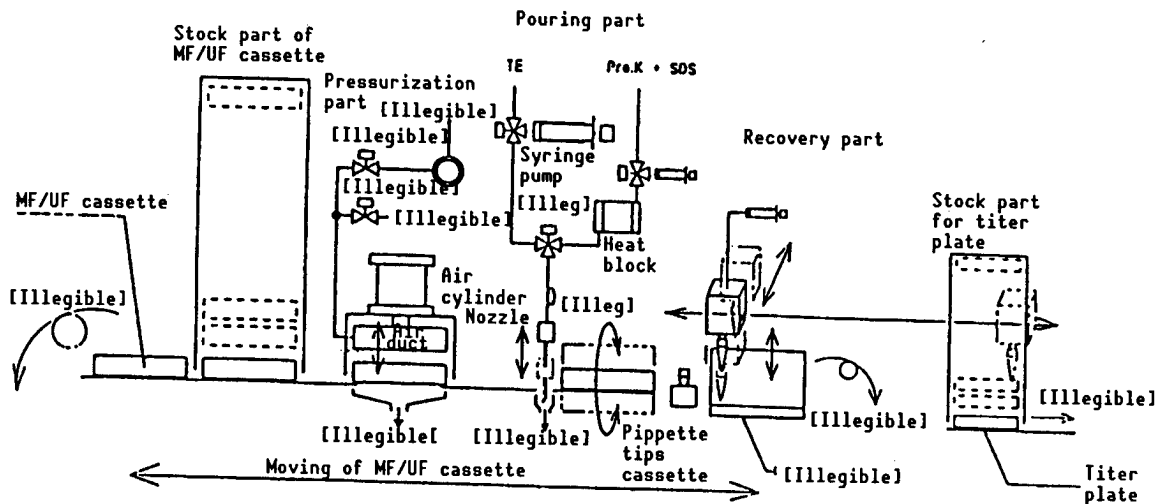

Figure 7. Flowsheet of Apparatus for DNA Extraction System

Based on the results obtained, the basic design for the apparatus was worked out. Whole figures are illustrated in Figure 7. This apparatus is composed of five parts: 1) MF/UF cassette; 2) pressurization; 3) pouring; 4) recovery; and 5) titer-plate stock. Henceforth, this apparatus will be trial manufactured.

(4) Plans for further research and development

- The trial membrane cassette will be evaluated and continually improved.
- Apparatuses will be trial manufactured.

2) Development of Sample Injection Apparatuses

(Name and affiliation) Masamitsu Saito (LS Apparatus Group, Seiko Co.)

(1) Object

The object of this research is to develop sample injection units for DNA sequencing systems for analyzing 100 Kb of human chromosomes per day.

This year investigations were aimed at establishing fundamental techniques to develop the sample injection units. The techniques were as follows:

- Establishment of basic techniques for injecting samples
- Establishment of basic techniques for detecting useful parts
- Establishment of basic techniques for the automated prerunning of electrophoresis

(2) Summary

(1) Establishment of basic techniques for injecting samples

Sample injection apparatuses were developed and trial manufactured. As the results of the confirmation test showed, it became clear that the apparatuses could be put into practical use by removing urea and bubbles, and automatically injecting into the 0.3 mm electrophoresis plates.

(2) Establishment of basic techniques for detecting useful parts

Techniques detecting useful parts were established by marking the starting position on the wells of the electrophoresis plates.

(3) Establishment of basic techniques for the automated prerunning of electrophoresis

Charging systems and the structure of electrophoresis tanks necessary for the automated prerunning were established.

(3) Text

(1) Establishment of basic techniques for injecting samples

(1) Outline

Since there were problems (written below) for injecting samples automatically into the preelectrophoresis apparatus, confirmation experiments were carried out to solve these problems, using an experimental, newly developed sample injection apparatus.

- The method for injecting samples in the wells of the electrophoresis gel with 0.3 mm in thickness
- The method for removing urea and bubbles accumulated in the wells

(2) Experimental sample injection apparatus

Photographs A and B are the experimental apparatuses, equipped with an injection pipette shown in Figure 8, having an injection needle on the top shown in Figure 9. Samples are injected by moving a piston of microsyringe with a stepping motor. Figure 10 is a pipetter for removing urea and bubbles by blowing out electrolytic solution.

(3) Results

Experiments for automated injection were repeated 160 times using the experimental apparatus written above, and satisfactory results were obtained in the injection, the removal of urea, and contamination, as shown in Photograph C.

Robot controller

Injection head

Robot

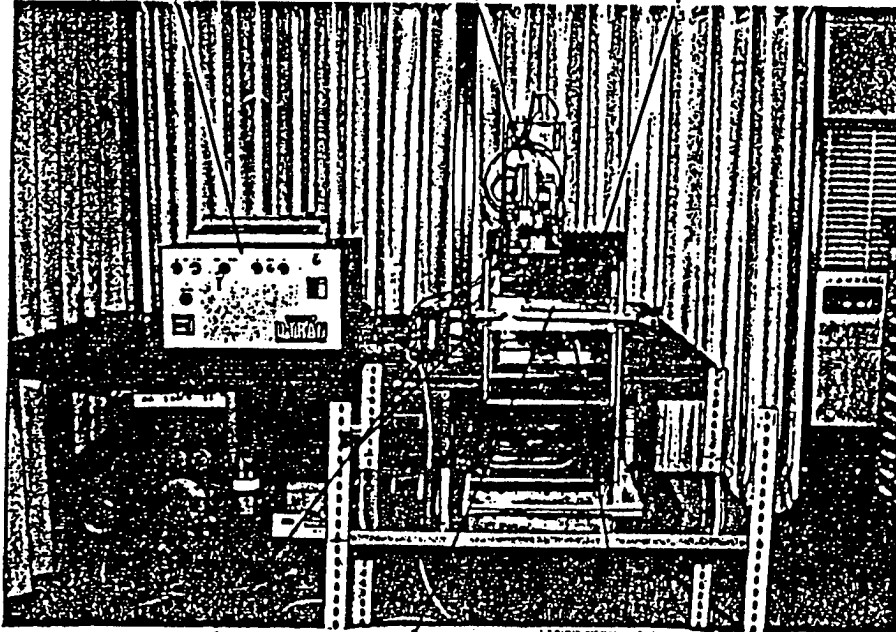

Stepping motor
Driver controller

Microtiter plate

Electrophoresis
apparatus

↑
 Photograph A. Experimental
 Sample Injection
 Apparatus:
 Whole View

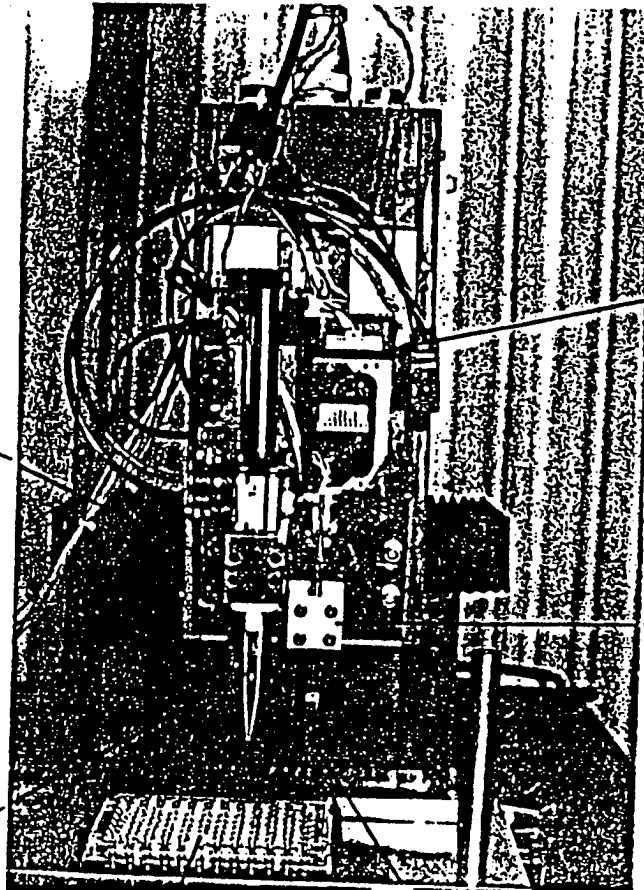

Motor for
pipette
(stepping
motor)

Removing
pipetter

Injection
pipetter
(micro-
syringe)

→
 Photograph B. Experimental
 Sample Injection
 Apparatus: Injection
 Head

Removing
needle
(1000µl tip)

16
Microtiter plate

Injection needle

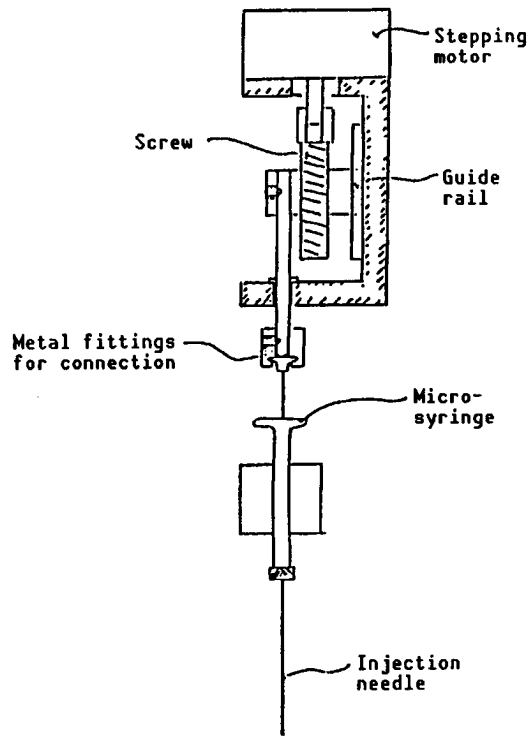

Figure 8. Injection Pipetter

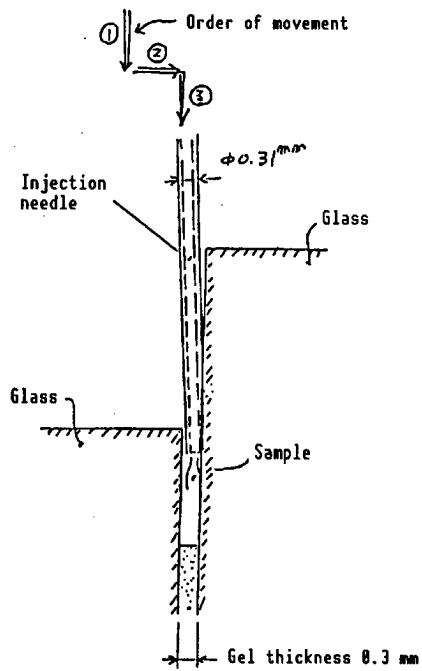

Figure 9. Injection Needle and State of Injection

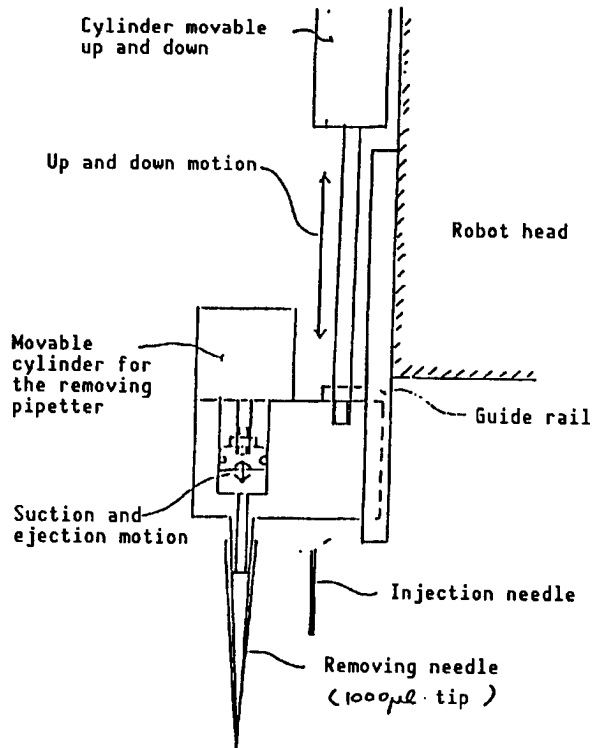
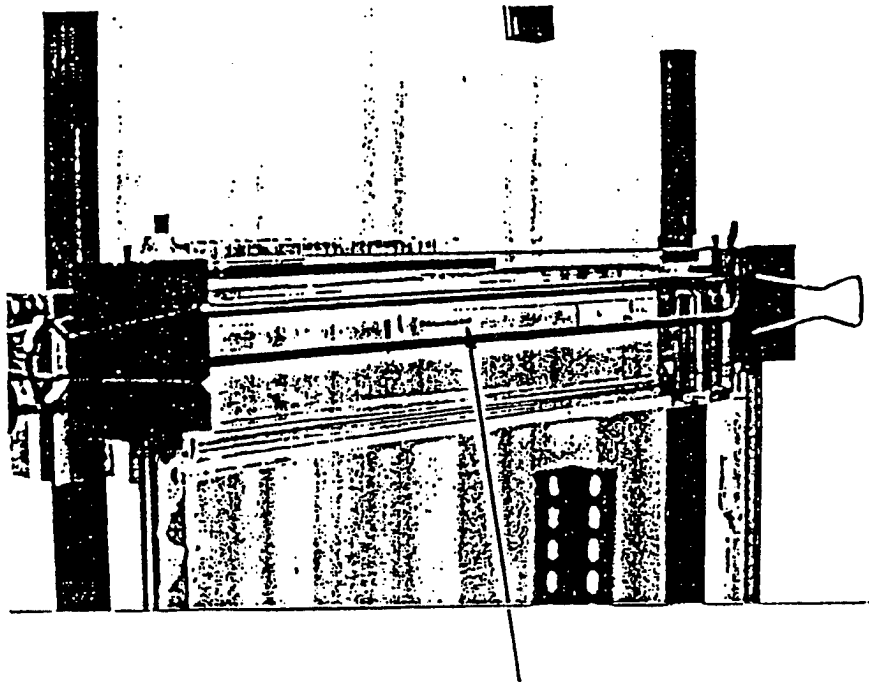

Figure 10. Removing Pipetter



Sample (dye) 4 lanes

Photograph C. State of Sample Injection

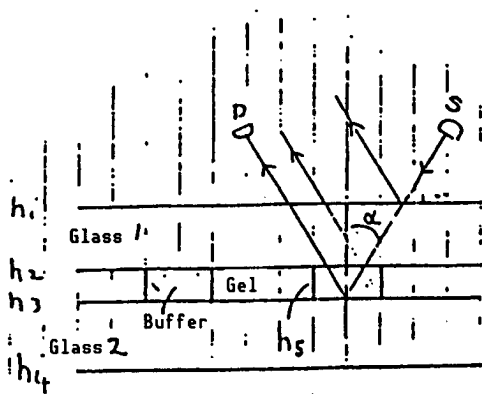

Figure 11.

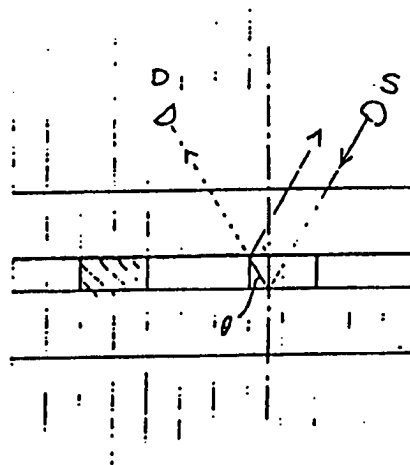

Figure 12.

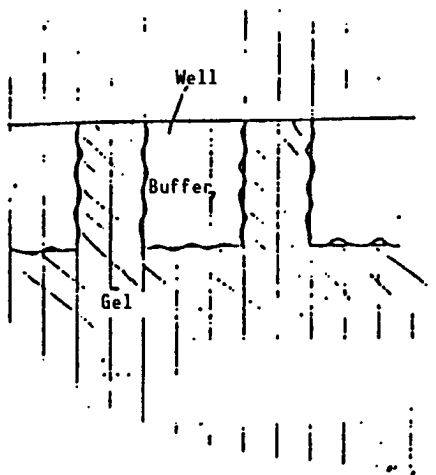

Figure 13.

(2) Establishment of basic techniques for detecting useful parts

(1) Outline

To recognize the application parts of the electrophoresis apparatus, experiments were carried out to detect the wall edge of the electrophoresis gel.

(2) Principle (Method)

Light axis is incident from a light source S to the glass (1) with α degree of angle from the horizontal direction on the front of electrophoresis (Figure 11).

Moving the light axis S to the left gradually, the light reflected on the surface h3 fits the interface (the well edge) h5 between the gel and the buffer solution. When the incident angle from the light source S reduces, the incident angle θ to the face h5 becomes a critical angle and totally reflects on the face h5.

In such case, the light quantity reaching the light obtaining part D is much reduced and the well edge can be detected.

(3) Results

- The useful part was able to be detected by accurately putting a marking like a bar code on the h1 face of Figure 11 at the starting position of the well of the electrophoresis plate.

- It may be possible to increase accuracy more constantly by solving the following items:

- Raising the parallel degree between the glass 1 and the glass 2 (Figure 11).

- Stabilizing the state of the gel.

(3) Establishment of techniques for the automated prerunning of electrophoresis

(1) Outline

Research was conducted to solve the problems written below (Footnote) (Not actually written in the paper) which exist in the case of prerunning in electrophoresis tanks after injection of samples.

(2) Research results

The method for constructing apparatuses was completed as follows:

An electrical current was applied to the electrophoresis tank at the conveyance part that also served as a buffer. Before that samples had been injected as shown in Figure 14. The electric current was cut off when the next tank was brought. Tanks were shifted successively and charged. Thus the method for charging was established.

Also for the communication of DNA sequencing system with the system controller, the electric source indication signal and the like were equipped to the apparatus.

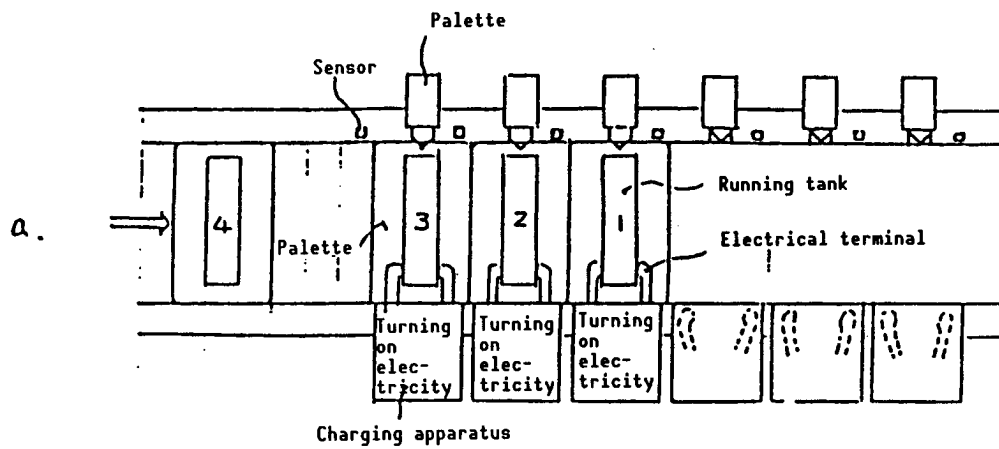

Running tank moves, shifted to 1-3, and set 4

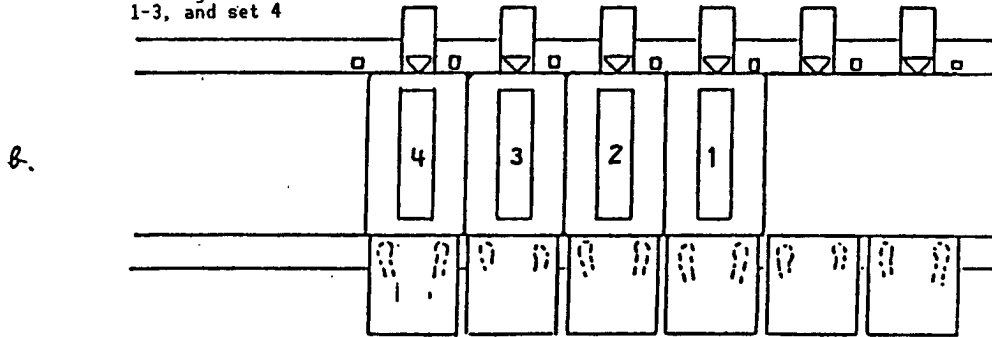

Turning on electricity for tanks 1-4

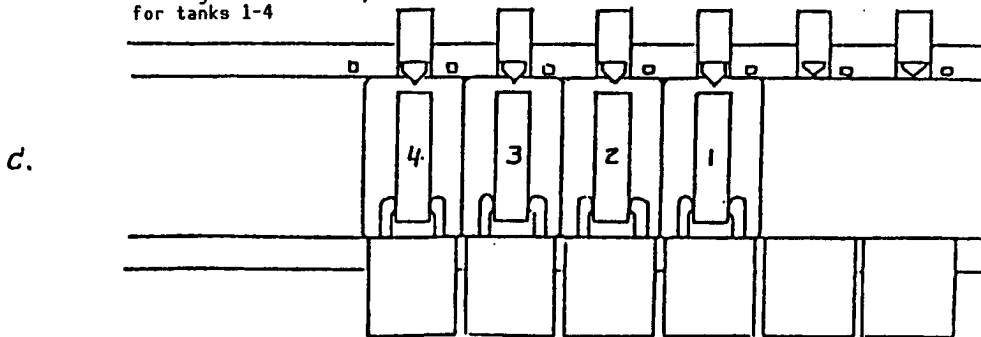

Figure 14. Conveyance Method During Prerunning

(4) Plans for further research and development

(1) Development of the experimental sample injection apparatus

Next year, the apparatus will be trial manufactured. Based on the fundamental techniques established in this year, the research and development will be advanced in the first half of the year for the design and in the second half for the manufacture of the apparatus.

3) Improvement and Development of a New Electrophoresis Apparatus

(Name and affiliation) Tomoaki Sumitani (Hitachi, Ltd.)

(1) Object

The object of this research is to develop and experimentally manufacture electrophoresis units with a fluorescence type of DNA sequencing system capable of analyzing with high speed and accuracy, to contribute to the plans for analyzing human genes.

In 1988 the following research was carried out as the first step:

- Establishment of direct detection techniques for fluorescence labeled DNA
- Development of fundamental techniques for enhancing function

(2) Summary

Several investigations concerning the basic functions were carried out on the direct detection apparatus for the fluorescence labeled DNA, developed by Hitachi, Ltd.

For developing fundamental techniques for enhancing functions, the following research items were investigated:

- Producing a fine pitch
- Unifying gel temperature
- Increasing the running length of electrophoresis

The results confirmed that 12 samples were simultaneously treated and 400 bases identified.

(3) Text

(1) Establishment of direct detection techniques for fluorescence labeled DNA

Functions of the direct detection apparatus for fluorescence labeled DNA developed by Hitachi, Ltd., were evaluated using yeast chromosome 6 genes as samples given by the Institute of Physical and Chemical Research. Results obtained for the evaluation of the apparatus were as follows:

- Comparison with RI method: Better data than those with RI method were obtained and therefore the above technique can be replaced with the RI method

- Basic functions: Number of samples treated simultaneously: 8
Length of bases distinguishable: more than 300
Time required for measurement: within 3 hours

(2) Development of fundamental techniques for enhancing function

(1) Objects of enhancing functions

Capabilities of the present apparatus are as follows:

Number of samples treated simultaneously:	8
Number of bases distinguishable	: 300
Running time	: 3 hours

Therefore, to treat 100,000 bases per day,

$$\begin{array}{l} 100,000 \div (300 \times 8) \approx 42 \\ \text{(bases) (bases) (sample)} \end{array}$$

that is, the ability must be increased about 42 times.

In this project the following were set for the targets of development, on the assumption that three apparatuses automatically operate seven cycles per day.

Number of samples treated simultaneously:	12
Number of bases distinguishable	: 400
Running time	: 3 hours

With these values, the fixed object will be achieved, according to the following calculation:

$$\begin{array}{l} 400 \times 12 \times 7 \times 3 = 100,800 \\ \text{(bases/sample) (samples) (bases)} \end{array}$$

(2) Development of fundamental techniques for enhancing function

Fundamental techniques necessary for enhancing functions were analyzed (Figure 15). As shown in the figure increasing the number of samples treated simultaneously cannot be accomplished by simply increasing the width of electrophoresis. The process needs to reduce smiling (lack of uniform movement on the parallel direction of gel). Also reducing smiling as well as increasing the running length are important to increase the number of bases distinguishable. Then, for performing the objects described above, the following were studied in detail and the evaluation tests were carried out using M13 mp 8 as a sample:

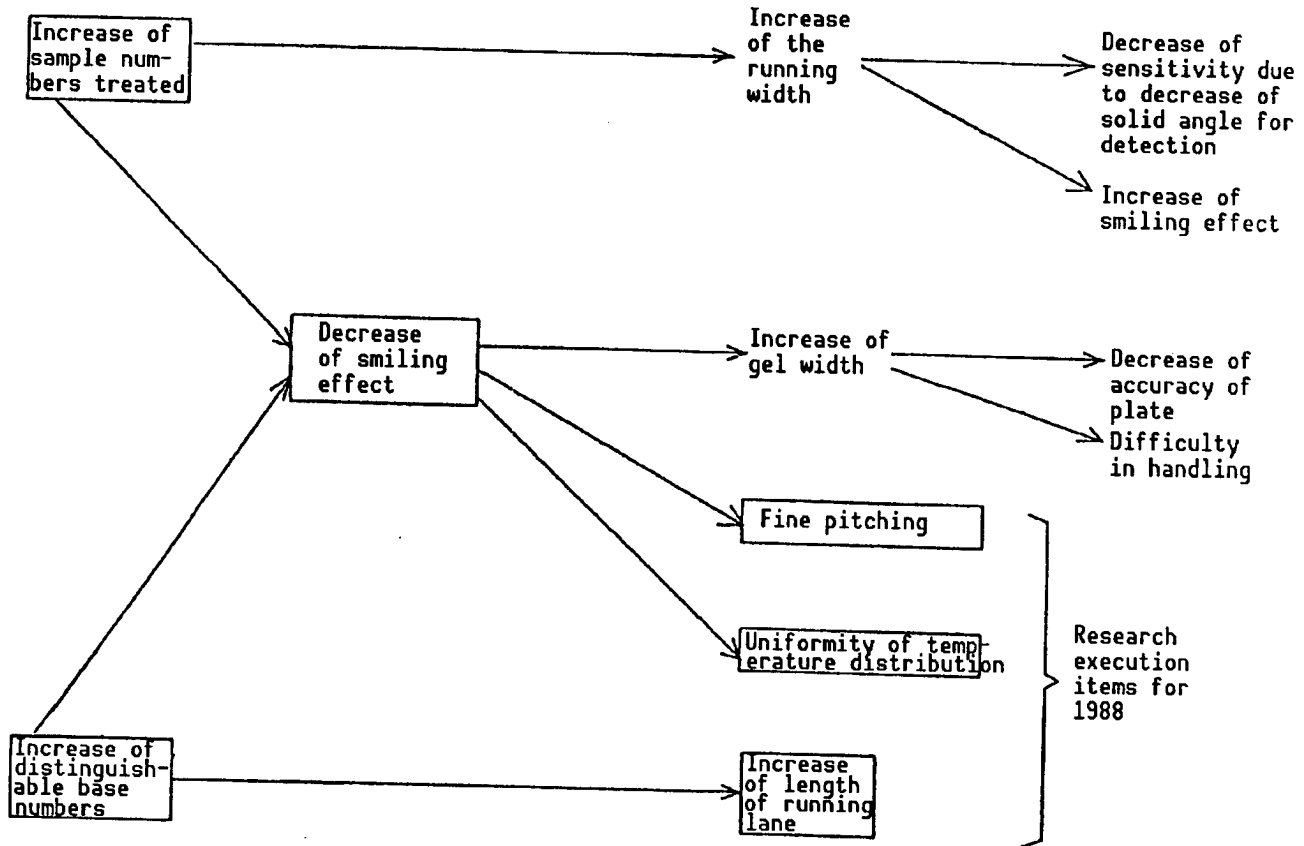

Figure 15. Fundamental Techniques for Enhancing Function

- Producing a fine pitch
- Unifying temperature distribution
- Increasing the running length of electrophoresis

(1) Producing a fine pitch

To reduce the effect of smiling, it is desirable to use the middle of the gel having relatively uniform temperature; that is, to increase the fine pitch of the gel lane.

On the other hand, the following problems may arise for increasing the fine pitch:

- Sample useful part (well) preparation
- Sample supply to the well
- Interference among lanes

Considering the abovementioned problems, several sizes of the well were examined. Based on the results, the shape of the well was determined as shown in Figure 16. The measurement results of samples are shown in Figure 17. In

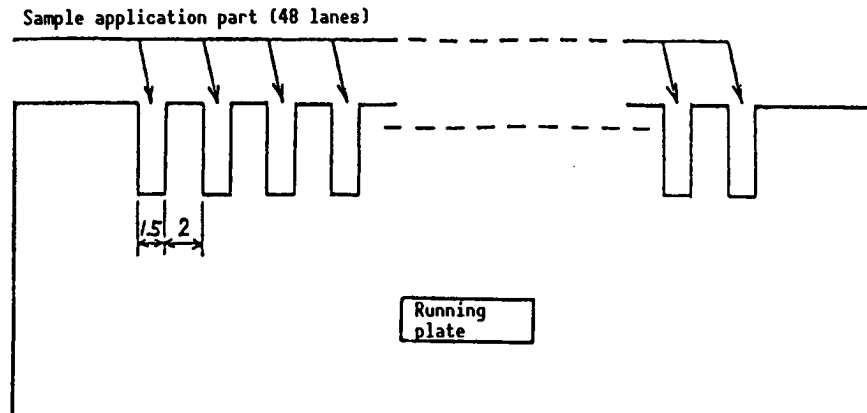

Figure 16. Shape of Well for Fine Pitch (Unit: mm)

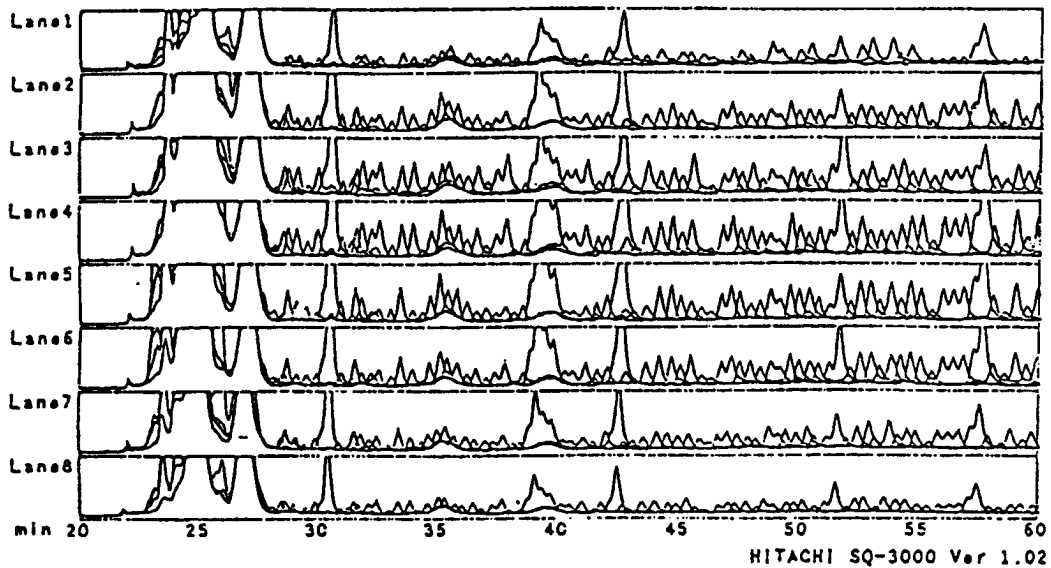

Figure 17. Results Measured During Fine Pitch

this example only eight samples were determined due to the circumstances of the apparatus. The total lane width for 12 samples in Figure 16, however, is 166 mm and the detection sensitivity is not a problem.

(2) Unifying temperature distribution

The smiling phenomenon is mainly due to the disparity in temperature on the gel surface. Figure 18 shows the temperature distribution on the ordinary plate in the running time and Figure 19 shows results of the measurement of samples. The smiling occurred on about 1.5 bases per 100 bases.

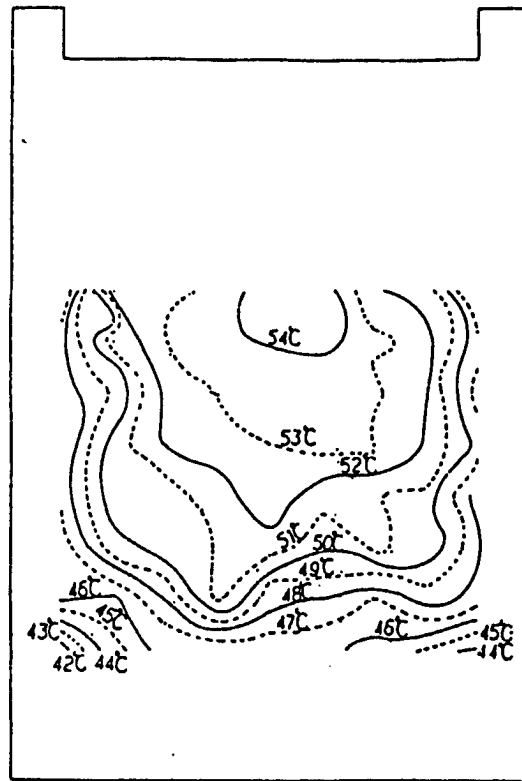

Figure 18. Temperature Distribution on the Running Plate
(Without radiation plate)

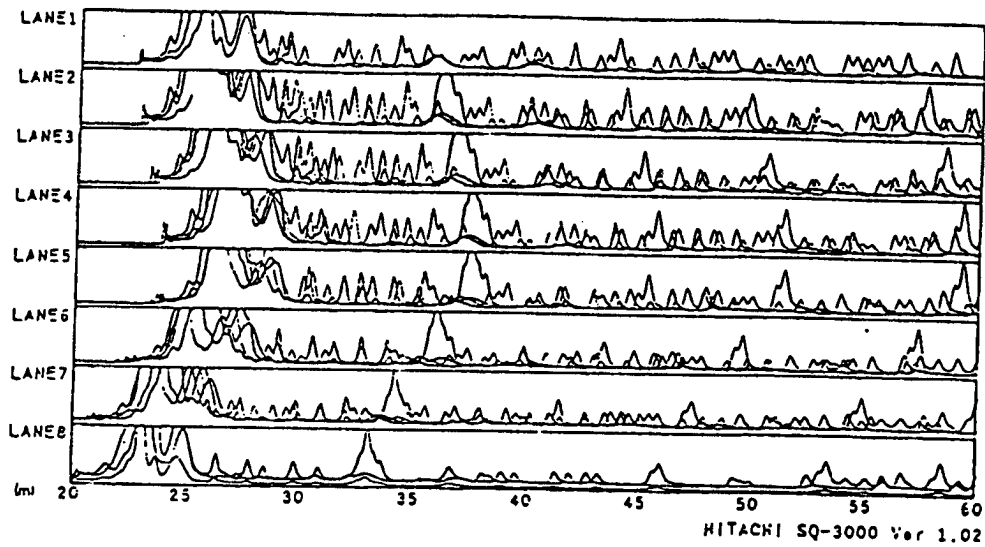

Figure 19. Measurement Results (Without radiation plate)

To unify the temperature distribution, several methods, such as water cooling and installing radiation fins, were investigated and a good result was obtained by installing an aluminum plate.

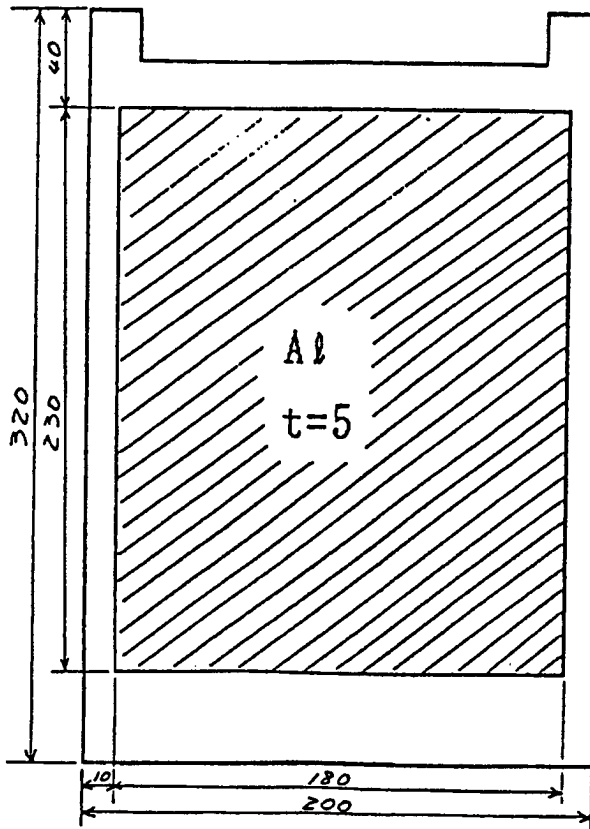

Figure 20. Outside Shape of Plate (With radiation plate)

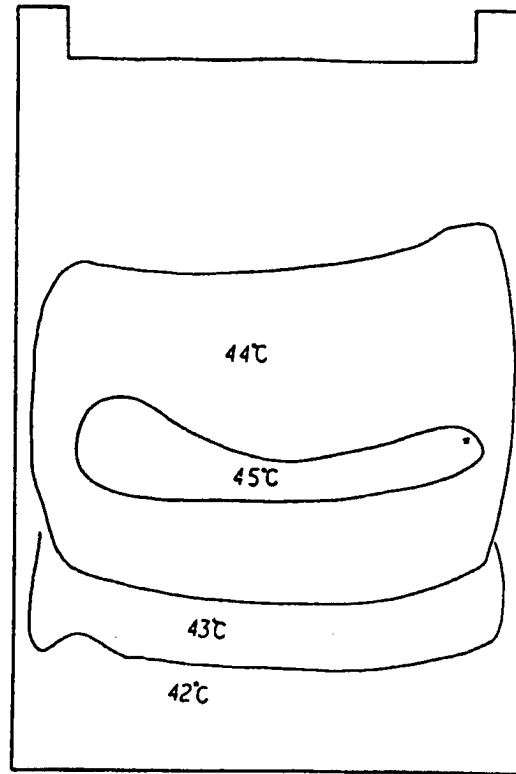

Figure 21. Temperature Distribution on Plate (With radiation plate)

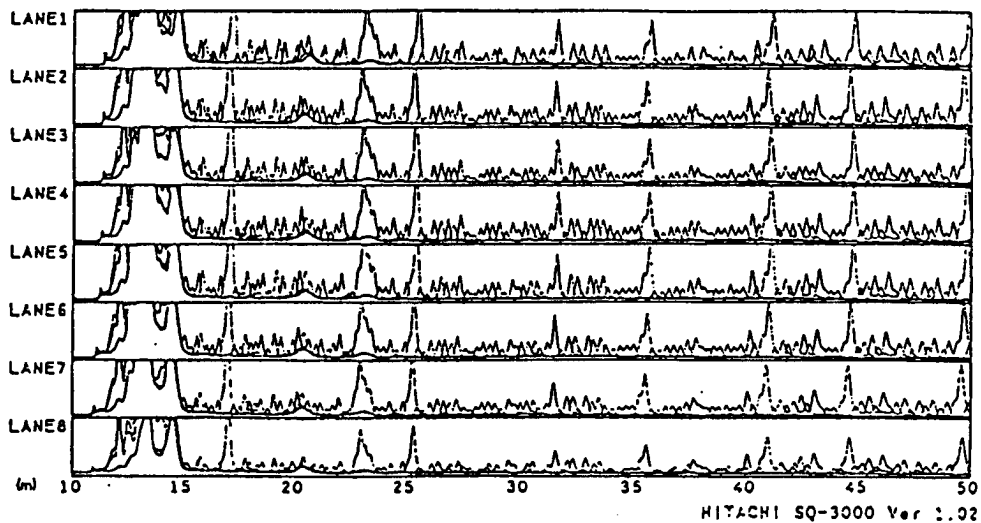

Figure 22. Measurement Results (With radiation plate)

The external form of the running plate attached with aluminum radiator fins is shown in Figure 20. The temperature distribution in the running time using this plate and the results of the sample measurement are shown in Figure 21 and in Figure 22, respectively.

The smiling observed was less than 0.5 base per 100 bases maximum, and there was no problem on resolution ability and sequence determination.

(3) Increasing the running length of electrophoresis

To increase the number of bases distinguishable, increasing of lane length is most effective. Increasing lane length, however, causes the increase of smiling and the disorder of running.

Due to the effect of the smiling reduction method described above, a stable electrophoresis became possible, even if the lane length increased from the ordinary 22.5 cm to 25 cm.

The separation ability was also improved and the determination of 400 bases was actualized (Figure 23).

From the investigations described above, it is possible that the number of samples treated simultaneously can exceed 12 and the number of bases distinguishable can exceed 400.

(4) Plans for further research and development

Based on the investigation results described above, functional apparatuses will be trial manufactured and the following abilities confirmed.

Number of samples treated simultaneously:	12
Number of bases distinguishable	: 400
Running time	: within 3 hours

4) Development of Software for Editing Base Sequences

(Name and affiliation) Shiyoh Eguchi (Integrated Institute, Mitsui Information and Development Co.)

(1) Object

The purpose of this research is to develop a system that automatically link-edits the fragments sequenced, with the ability of 100,000 bases per day, as a part of the development of the computer system for supporting the human DNA sequencing by shotgun methods.

(2) Summary

As a software for editing base sequence data, a program having the following four functions was developed:

- A program for accumulating DNA fragments in the data base for a linkage editor
- A program for removing the part of vector sequence in DNA fragments
- An automated link-editing program for DNA fragments
- A program for correcting the link-edited sequences

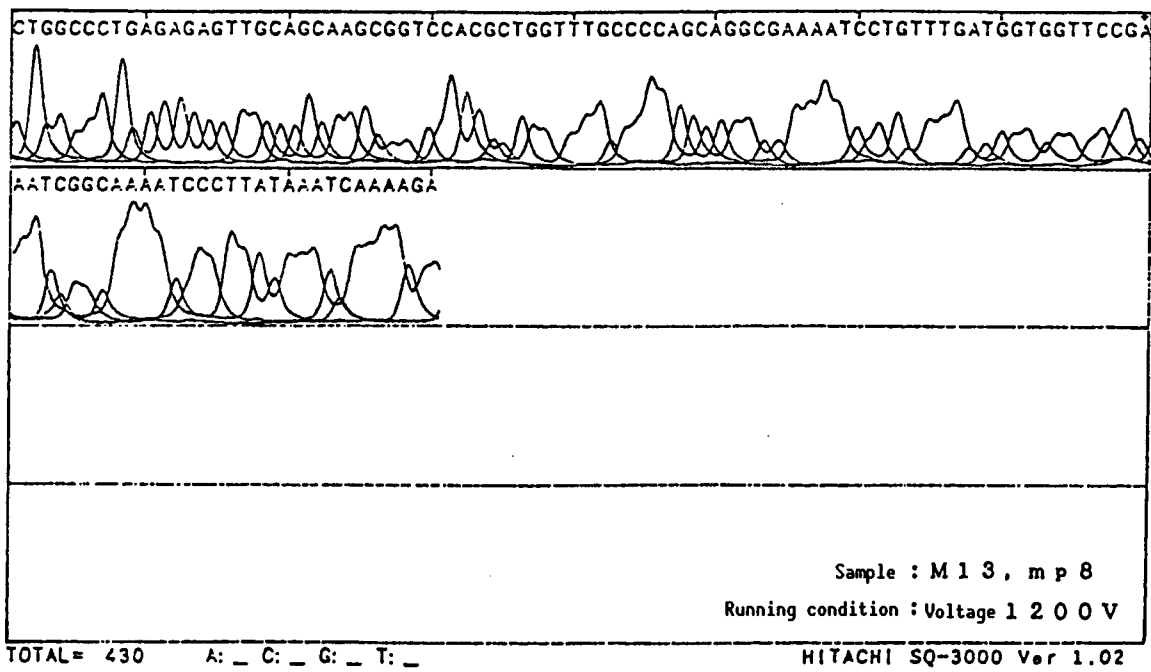
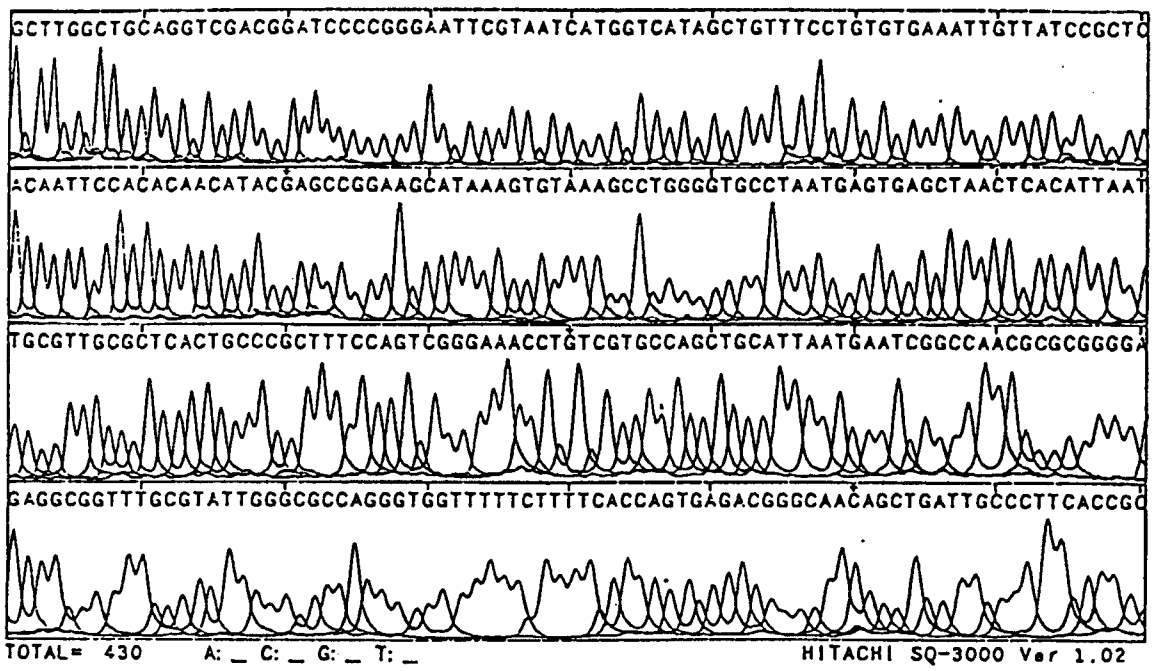

Figure 23. Measurement Results After Improvement
 (The length of lane: 25 cm)

The processing ability of the automated link-editing program has achieved its expected results.

(3) Text

(1) Explanation of programs

(1) A program for accumulating DNA fragments in the data base for a linkage editor

The following processes are carried out for the base sequence data included in the data base designed for link-editing:

(1) A table of base sequence data

A table for the names of base sequence data is shown on a screen. It is also possible to output to a printer by commands.

(2) A list of base sequence data

The table for the names of base sequence data is shown on a screen. Arbitrary data can be freely output to a printer by the GenBank Format.

(3) Calculation of the total number of base sequence

The total number of base sequence in base sequence data, separated by the generic character, is calculated and shown on a screen.

(4) Removal of base sequence data

The table for the names of base sequence data is shown on a screen. Arbitrary base sequence data are freely removed from the data base.

(5) Change of the names of base sequence data

The table for the names of base sequence data is shown on a screen. The name of arbitrary base sequence data is changed.

(6) Change of the generic character of base sequence data

The table for the names of base sequence data is shown. The name of generic character of arbitrary base sequence data is changed.

(7) Reading in of base sequence data

Base sequence data written in the GenBank Format or EMBL are read in.

(8) Output of base sequence data

The list for the names of base sequence data is shown. The name of arbitrary base sequence data is output with the GenBank Format.

(2) A program for removing the part of vector sequence in DNA fragments

It is a program for searching highly similar fragments to a given vector sequence and removing it from the data base, or inactivating it for the linkage editor manipulation. Editing base sequences as well as removing vector sequences are possible by the program.

(3) An automated link-editing program for DNA fragments

An automated linkage editor is manipulated for all active fragments accumulated in the data base. In the case of human chromosomal genes, because of the existence of numerous repeats the reconstruction of repeated sequence is difficult, if comprehensively edited by reference to only short common sequences that are completely consistent. Therefore, a linkage editor system adopting the homology analysis between two sequences was chosen.

(4) A program for correcting the link-edited sequences

This program is for carrying out a new construction and revision of base sequence data in the data base. Editorial functions are the insertion and removal of base sequences, the composition of inverted and complementary strands, the input of comments, and the search of arbitrary base sequence. A two-strands editor was constructed with link-edits two base sequence data on a screen and carries out the continuous processing, using consensus sequences as masters. An n-strands editor was also constructed that edits arbitrary consensus sequences and their elemental base sequences on a screen.

(2) Processing ability

The automatic linkage editing program was tested with five kinds of shotgun sequencing experimental data. A computer used was Micro VAXII, the lowest class of processing ability in the VAX series. The results are shown in Table 3.

In a regression analysis for the number of fragments, where N = processing time, and T (hours), the following equation was obtained with a determination coefficient of $R^2 = 0.9968$.

$$T = 1.38 \times 10^{-4} \times N_2$$

This shows that the processing time is determined mainly on the number of fragments. With this premise, if the average number of bases is 400, then $N = 250$, that is, 100,000 bases can be processed in about nine hours.

(4) Plans for further research and development

At the present stage, individual programs are being composed and the basic abilities tested. In the next stage, tests will be conducted cooperatively with researchers and systems will be improved for their easy use as a total system.

Table 3. Processing Ability of the Automatic Link-Editing Program

Name of data base	Active		Processing time (h : m : s)
	Number of fragments	Total number of bases (average number of bases)	
A	42	8,882 (211)	00 : 17 : 17
B	115	24,949 (217)	01 : 56 : 04
C	108	29,612 (274)	01 : 41 : 35
D	250	52,385 (209)	07 : 44 : 52
E	339	80,714 (238)	16 : 22 : 47

This system will support sequencing experiments for human chromosomes carrying numerous repeated sequences, from the beginning to the end. The improvement and evaluation process will be tried for this system.

5) Development of Gel Preparation Apparatus and System Controller

(Name and affiliation) Katsuo Nishi, Hiroshi Kato (Technology Laboratory for Ultimate Environment), Hideo Nakatani (Technology Laboratory for Development of Research Apparatus)

(1) Object

A gel preparation unit for DNA sequencing system capable of analyzing with high speed and accuracy, along with the system controller, are experimentally manufactured and developed for the analysis of human chromosomal genes.

(2) Summary

The gel preparation apparatus under development automatically pours gel, stabilizes, performs clean-running, and supplies 21 electrophoresis tanks per day. The electrophoresis is able to analyze 12 samples having 400 base pairs for each, within three hours. The system controller controls all sequences with the transfer system as the center, monitoring the working state of each device, all through the day.

(3) Text

Concerning the gel preparation apparatus, the determination of main specifications, the investigation of apparatus structure, and the recognition of problems for establishing fundamental techniques and their countermeasures were investigated this year. Some experimental equipment has been purchased for these purposes.

Concerning the system controller, investigations were carried out for the overall construction, the processing ability considering the treating devices developed by future research, and the countermeasures for automation. Also, an outline about the signal acceptance and control with each treating device has been fundamentally completed.

(4) Plans for further research and development

(1) Development of the gel preparation apparatus

- Establishment of a protocol
- Design of a prototype and trial manufacture
- Evaluation of functions

(2) Development of the system controller

- Standardization of signal lines
- Design and manufacture of hardware and software including interphase
- Development of software concerning unusual signals, supplementary signals, and graphics

6) Development of Fundamental Techniques for Sequencing Systems

(Name and affiliation) Eiichi Soeda (Laboratory of Gene Bank, Institute of Physical and Chemical Research)

(1) Object

Sequencing systems can be completed through several processes. The object of this research is to conduct the operation and evaluation test on the automated apparatuses for each of these processes, which were trial manufactured by different companies, aiming at developing their systematization.

(2) Summary

Fluorescence sequencer (Hitachi)

Operation test and its evaluation for the first manufactured apparatus were carried out from September to December 1988.

The second apparatus that was improved according to the results obtained by these experiments was able to analyze 300 bases on average and 500 bases maximum.

Purification extraction apparatus (Tosoh)

The establishment of the purification extraction method using filters in a laboratory was tried. The result was that the recovery of DNA was successful but the evaluation at the level of sequencing has not been done yet.

Software evaluation for editing base sequences

Introducing to the Tsukuba Center, operation tests were carried out. At present, several fragments of yeast chromosome 6 have been linked.

(3) Text

(1) Evaluation of the basic design of the DNA extraction-purification unit

The extraction-purification method proposed by Tosoh Company was examined and evaluated with a manual using M13 phage.

Examination items:

- Concentrations of phage and the titer measurement of phage
- DNA extraction and agarose electrophoresis
- Examination with sequence

As to the filter method, the filter was selected and fundamental techniques were investigated that are prerequisites for the general design for the shape of the supporter. DNA samples were prepared and the tests described above were carried out.

Among these, the removal of host bacteria with the filter method was successful, as were the concentration of phages and the extraction of DNA. Expected results, however, were not obtained for these DNA samples in the examination by sequences.

(2) Evaluation of electrophoresis unit

Efficiency evaluation was carried out for the fluorescence sequencer introduced by Hitachi, Ltd., and the following tests were performed for the comparative verification:

- Comparison of functions with the conventional RI method (accuracy, cost, and ability)
- Comparison with existing sequencers

In the case of the first trial apparatus, satisfactory results were obtained with standard samples but errors or reading mistakes occurred when a large number of clones of yeast chromosome 7 were used. After improving the software, now six samples can be simultaneously analyzed, and 300 bases can be read on average and 500 maximum per sample. The error is 1-3 percent for up to 300 bases but increases up to 500 bases.

This is a superior result to that obtained by the automated read-in system in RI method (200 bases average and the error is about 10 percent) and enables to read in more bases than those done by eyes. The cost per base is ¥18 with the RI method and about ¥3 with the fluorescence method. The fluorescence method is superior to the RI method in accuracy, ability, and cost.

(3) Evaluation of software for editing base sequences

The original data (300 bases average) produced from sequencing systems were input in a computer and edited for completing base sequences of 50 Kb human gene DNA.

- Original data containing all regions of cosmid clones which include human gene DNA were offered to Mitsui Information Development Company to promote the development of software.
- For evaluating the editing software developed, editing was tried on all sequences of yeast chromosome 6 from original data.

An original software has already been completed and tests using yeast have been working satisfactorily.

(4) Plans for further research and development

The extraction-purification apparatus of Tosoh Company must thoroughly be tested at a basic laboratory level. At the same time, experts who have sequencing techniques will be trained as soon as possible.

The fluorescence sequencer (Hitachi) has completed its objective this year. Time-consuming problems still remain concerning the systematization and automation, which must be improved.

The software of Mitsui Information Company has actually analyzed 400 Kb human gene DNA. Its ability will be further improved using raw data of yeast sequences.

2. Maintenance of Genetic Materials and Analytical Techniques

1) Preparation of Genetic Materials

(1) Development of Material Preparation Method

(1) Collection of hybrid cells containing human chromosomes and construction of human chromosome panel

(Name and affiliation) Yasubumi Murakami (Gene Bank Laboratory, Institute of Physical and Chemical Research)

(1) Object

The object of this research is to collect hybrid cells having human chromosomes, especially rodent cells having human chromosome 21, and investigate methods for their storage. Methods for isolating DNA replication origins are also investigated as the preparation for synthesizing artificial chromosomes.

(2) Rodent cells having human chromosome 21 were collected, propagated, and stored as the hybrid cells having human chromosomes. Human normal diploid cells were also collected and stored. As preliminary experiments for isolating DNA replication origins, experiments were performed to establish an affinity purification method for DNA polymerase α affinity which plays a central role in DNA replication.

(3) Text

(1) Research materials and methods

(a) Preparation of protocol for collecting and storing cells having human chromosomes

Hybrid cells having chromosome 21 were collected as an example of hybrid cells having human chromosomes and a protocol was prepared from collection through storage. Along with hybrid cells, 153E9b (established by Dr. Patterson) and its mother stock, CHO cells were obtained, and the cell storage conditions were investigated according to the following order.

- Accepting cells
- Storing cells as proof cells, after subculture
- Investigating cells on contaminated microorganisms
- Examining the caryotype of cells (currently, conditions are being studied and examination manuals written)
- Thawing frozen cells and confirming the survival of cells
- The first large-scale culture
- Preparing the first stock

A container for liquid nitrogen with 430 liter capacity purchased as a storage container was connected to an existing line for supplying liquid nitrogen,

producing a system in which liquid nitrogen is automatically supplied. Both liquid and air storage were used.

Also three stocks of human normal diploid cells were collected and stored.

(b) Conduct of preliminary experiments for isolating DNA replication origins

To isolate DNA replication origins in higher animal cells, the following preliminary experiments were started:

- Studies were aimed at improving *in vitro* DNA synthesis system of SV 40 and increasing the dependency on T antigen, which is the ignition factor of virus DNA synthesis.
- To identify the DNA replication origin in higher animal cells, affinity purification was investigated for DNA polymerase α known to play a key role in DNA replications, and its interacting factors were analyzed. For this purpose, two kinds of hybridoma that secrete antibody against the DNA polymerase α were collected and stored. Establishing the method for purifying DNA polymerase α was tried using this antibody.

(2) Research results

(a) Preparation of protocol for collecting and storing hybrid cells having human chromosomes

One hybrid cell stock and one parental stock among cells collected (one hybrid cell stock, one parental stock, and three human normal diploid cell stocks) were proliferated and stored, according to the flowchart [Figure 7]. There was no problem on the proliferation after storage. The storage container and liquid nitrogen supply system were also confirmed to work normally. Thus the first step for storing important genetic sources over a long period of time was successful.

(b) Preliminary research for isolating DNA replication origin

The purification method of DNA polymerase was established employing HeLa cells as a starting material. Antibody columns were prepared using purified enzymes and currently the DNA replication origin is being analyzed.

(4) Consideration

Though the investigation on general conditions necessary to collect and store cells has been almost completed, eliminating human chromosomes from hybrid cells during the freezing-thawing period must be studied.

It has been clear from recent research that the entry of RNA synthesizing enzyme complex to chromatin has an important role on the expression mechanism of genes.

Following this sample, analyses may be necessary for the DNA replication complex and the mode of entry at the time of DNA replication.

(5) Plans for further research

- Hybrid cells having other human chromosome 21 will be collected and stored.
- Hybrid cells collected will be investigated and analyzed.
- Hybrid cells having other human chromosomes will be collected.
- Factors interacting with DNA replication enzymes will be analyzed. Furthermore, their functions in DNA replication origin sites which recognize these factors will be investigated.

(2) Separation of chromosomes by sorting and construction of genomic libraries

(Name and affiliation) Nobuyoshi Shimizu (Keio University)

(1) Object

The object of this research is to develop techniques for separating human chromosome 21 with sorting, and isolate and identify the NotI fragment of the chromosome with pulsed-field gel electrophoresis. Furthermore, specific genomic libraries are constructed using chromosome 21 sorted.

(2) Summary

Techniques were established for isolating pure chromosome 21 or single chromosome 21 homologue from human lymphocyte B cells, quickly and without damage, using a FACS440 cell sorter. Furthermore, NotI fragments sorted were separated with pulsed-field electrophoresis, and fragments containing Alu sequences were identified. Also the construction of NotI genomic libraries specific to the chromosome was tried using YAC (yeast artificial chromosome) vectors.

(3) Text

(1) Research materials and methods

Human lymphocyte B cell stock GM00130B having normal karyotype (46, XY) was used to separate chromosome 21 and also human lymphocyte B cell stock GM06135[46, XY, t(10; 21)(10qter>10p11.2::21q22.3>21qter;21pter>21q22.3::10p11.2>10pter)] having translocations for the separation of single chromosome 21 homologue. Chromosomes were prepared by the polyamine-digitonin method. Hoechst 33285 (H33285), Chromomycin₃ (CA3), or propidium iodide (PI) was used for fluorescent straining of chromosomes. After concentrating with centrifuge, sorted chromosomes were applied in the agarose gel blocks with a low melting point, treated with proteinase K and NotI, and then used for pulsed-field electrophoresis or cloning by YAC vectors.

(2) Research results

Human chromosome 21, which had not been separated by ordinary sorting methods using a single laser with H33258, was able to be separated by the dual laser system using double staining with H33258 and CA3. It was also found that chromosome 21 is separable with a single laser when used with PI stain; this system was used for the sorting thereafter.

Chromosome 21 and chromosome 22 adjacent to it were sorted from GM00130B cells, separated with pulsed-field electrophoresis after NotI cleavage, and analyzed with Southern blot using human repeated sequence Alu as a probe. NotI fragment specific to each chromosome was clearly recognized, and it was confirmed that the chromosomes were not damaged by the sorting and chromosome purity was high. Furthermore, single homologue of chromosome 21 was sorted from GM06135 cells having translocation t(10;21) and similarly analyzed. At least 28 Alu(+)NotI fragments composed of about 40 Kb minimum and 2,500 Kb maximum were identified and their total length was about 16 Mb. Ten million sorted chromosome 21 were cut with NotI and cloned using YAC vector. Sizes of YAC clone were determined for 27 of 200 clones obtained. All fragments were smaller than 50 Kb. Seven of 10 clones having about 40 Kb fragments contained rDNA.

(4) Consideration

It was confirmed that chromosome 21 and its homologue can be rapidly sorted without damage and treated in agarose gel blocks, using our method. The total length of Alu(+)NotI fragments identified with pulsed-field electrophoresis is about 16 Mb and covers about 33 percent of the total length of chromosome 21 (presumably 48 Mb). Most of the rest would be NotI and Alu(-)NotI fragments with more than 3 Mb, which could not run under present conditions. It is necessary to change running conditions and identify large NotI fragments. Since NotI fragments have been known to cluster together in rDNA genes located on the short arm p12 of chromosome 21 with about 80 copies supposedly, it was suggested that the low molecular weight NotI fragments derived from rDNA must be removed in the case of construction of NotI sequence libraries by YAC vectors.

(5) Plans for further research

- Conditions of pulse-field electrophoresis will be investigated and identification of NotI fragments having more than 300 Mb will be tried. The correspondence of each NotI fragment to the known probes (Arufoido) sequence, telomere sequence, cDNA, RFLP marker, etc.) will be investigated.
- Only NotI linking segment from chromosome 21 DNA sorted will be amplified using the polymerase chain reaction (PCR) method and NotI linking libraries will be constructed. DNA fragments including both ends and inside of each NotI segment separated with pulsed-field electrophoresis will be amplified by the PCR method and cloned.

- Using YAC vectors, DNA fragments of chromosome 21 and its single homologue will be cloned to construct NotI genomic libraries specific to chromosome 21.
- Using clones obtained in the first two items, the physical map of chromosome 21 will be constructed.

(3) Construction of giant DNA libraries and selection of DNA clones using yeast artificial chromosome vectors.

(Name and affiliation) Eiichi Soeda (Laboratory of Gene Bank, Institute of Physical and Chemical Research)

(1) Object

The purpose of this research is to clone fragments of chromosome 21, which is the smallest human chromosome, and finally construct clone libraries that cover an entire length of chromosome 21. To accomplish this, libraries will be constructed by cloning DNA with a molecular weight as large as possible, using the YAC vectors developed recently.

(2) Summary

As shown in Table 4, 52 stocks and 61 stocks of clones were obtained by cutting with restriction endonuclease EagI and NotI, respectively. EagI clones were independent and contained DNA with an average of 100 Kb. NotI clones covering 20 percent of the total region of chromosome 21 have not been analyzed yet but contained DNA with an average of 120 Kb, covering 24.8 percent of the total region of the chromosome.

(3) Text

(a) Research materials and methods

Hybrid cells of human-Chinese hamster containing human chromosome 21 were used as the starting materials. For obtaining long DNA chains, the sucrose density gradient centrifugation and agarose granule method were investigated.

DNA purified with the agarose granule method was partially digested with EagI and NotI to obtain an objective 100-500 Kb of DNA.

After being connected to YAC vectors, this DNA was introduced into yeast cells to obtain recombinants.

To select clones derived from human chromosomes, colony hybridizations were carried out using Alu sequence as probes specific to human chromosomes.

(b) Research results

(a) Extraction of long-chain DNA and partial digestion of DNA with restriction endonucleases

DNA extracted from cells using pulsed-field electrophoresis was analyzed with the sucrose density gradient centrifugation. The results showed that the long-chain DNA is physically cleaved in solution due to agitation and it is difficult to obtain DNA longer than 1 Mb. On the other hand, DNA molecules were kept stable in agarose and could be prepared without damage. Accordingly, all procedures from the extraction of DNA to the preparation of recombinant DNA were carried out in agarose. Partial digestion was performed with restriction endonucleases, EcoRI, NotI, and EagI. Concentration of the enzymes was reduced to one-tenth in each solution for the digestions. The results showed that products with various lengths of DNA were obtained. Among these, products 30-1,000 Mb in size were connected to YAC vectors and transfected to yeasts.

(b) Construction of YAC libraries and selection of human chromosome 21 clones

DNA obtained from hamster cells containing human chromosome 21 and purified with agarose beads was digested with NotI and EagI. YAC vectors digested with EagI and BamHI were treated with alkaline phosphatase, added to beads, and then ligated by ligase. After removing unreacted vectors, the beads were melted by heat treatment and transfected to yeasts. Recombinant yeast cells were selected with urea-media and transferred on filters. Clones containing chromosome 21 were selected using DNA labeled with radioactive compound as a probe.

(c) Approximately 1,200 clones were obtained with 1 μ g of DNA and 0.5 percent of them were derived from chromosome 21. The molecular weight of the inserted DNA in recombinants was determined with pulsed-field electrophoresis. The results showed that 30-170 Kb of DNA was inserted into each clone.

(d) As shown in Table 4, 52 clones containing an average of 100 Kb of DNA were obtained from EagI libraries and 61 stocks of NotI clones containing an average of 120 Kb of DNA from NotI libraries.

(3) Consideration

With the development of the agarose-beads method, it became possible to construct YAC libraries using a small amount of DNA, a previously difficult task. Furthermore, the selection for #21 in Alu segments is easy with #21-hamster hybrid cells. Enhanced efficiency was also sought for the collection of YAC clones, the precondition for the construction of a Kontigs map, which itself, is the ultimate object.

Table 4. Screening of YAC Clones Containing Chromosome 21

Treatment process	<u>EagI</u> library	<u>NotI</u> library
First transformation	3,114 (100%)	6,241 (100%)
Second transformation	2,304 (74%)	2,976 (48%)
4 x dot blotting	236 (7.6%)	693 (11%)
1 x dot blotting	52 (2.3%)	61 (2%)
Total	4,630 Kb (9.7%)	7,329 Kb (16.3%)
Total chain length	11,950 Kb (24.8%)	
Proportion to chromosome 21	11,950 Kb (24.8%)	

The results show that 24.8 percent of chromosome 21 was covered but analysis for NotI clones has not been completed yet. Therefore, if duplicated regions are eliminated, approximately 20 percent would be collected.

(4) Further plans

- Collection of YAC clones containing human chromosome 21: As for EagI clones, approximately 100 stocks will be collected.
- Partial digestion with EcoRI will be newly tried and clones will be collected.
- DNA will be collected not only from hybrid cells but also from human leukocyte cells to construct giant DNA libraries. The evaluation method of chromosome 21 clones will also be investigated.

(2) Development of Ordering Techniques

(1) Development of handling techniques for giant DNA clones

(Name and affiliation) Kazunari Yokoyama (Laboratory of Gene Bank, Institute of Physical and Chemical Research)

(1) Object

To develop the ordering techniques for human chromosome giant DNA clones and the subculturing techniques, the PCR method and T7/SP vectors were developed for establishing simple and efficient methods that enable cloning of several hundreds Kb of segments to YAC and cosmid vectors.

(2) Summary

After high molecular weight DNA was isolated from hybrid cells containing human genome No. 21 with the agarose-beads method, the DNA was ligated to YAC vectors and YAC libraries were constructed from human chromosome 21 and 6. To develop the ordering method, conditions were investigated using the PCR method.

Though the construction of T7/SP6 vectors was carried out in parallel, one of the vectors was selected from the point of efficiency and used as the technique hereafter.

(3) Text

(1) Research materials and methods

High molecular weight DNA was isolated from hamster hybrid cells containing human chromosome 21 and mouse hybrid cells containing human chromosome 6. The agarose-beads method was applied to the high molecular weight DNA. The DNA was ligated to the arm DNA with the telomere of yeast artificial chromosome vectors and then transformed into yeast cells.

Clones were obtained from genes introduced in these YAC libraries. The DNA of the clones was digested with restriction enzymes, circularized, and amplified by the PCR method using the arm region of yeast artificial chromosome as a primer. Clones having both ends were identified.

(2) Research results

Giant DNA clones isolated from the human chromosome 21 and hamster hybrid cells, the human chromosome 6, and mouse hybrid cells using the agarose-beads method were identified, amplified, and then ligated to YAC vector, to produce YAC libraries specific to the chromosomes. Until now, approximately 5,000 chromosome 21 YAC clones and 3,000 chromosome 6 clones have been obtained. Using one of these YAC clones, fundamental conditions for ordering were established using the following method (PCR method):

- Clone to EcoRI site
- Cleave with EcoRV and HincII
(add other enzymes when needed)
- Circularize and subject to PCR

Primers were synthesized for both ends of cloning site ((2),(3)), neighbor of EcoRV site ((1)) and that of HincII site ((4)). After all YAC clone DNA containing human chromosome 21 were separated with pulsed-field electrophoresis, regions inserted human DNA were cutoff with EcoRI. The DNA was cut with EcoRV and HincI, and then circularized with T4 DNA ligase. Adding primer ((1)+(2)) or ((3)+(4)) to the reaction mixture, the PCR reaction was carried out.

The results are shown in Figures 24 and 25 below.

(4) Consideration

Due to the high concentration of primer used, many bands of PCR appeared. Also there are problems on the concentration of restriction enzymes. There is room for further study on ligation conditions for circularization.

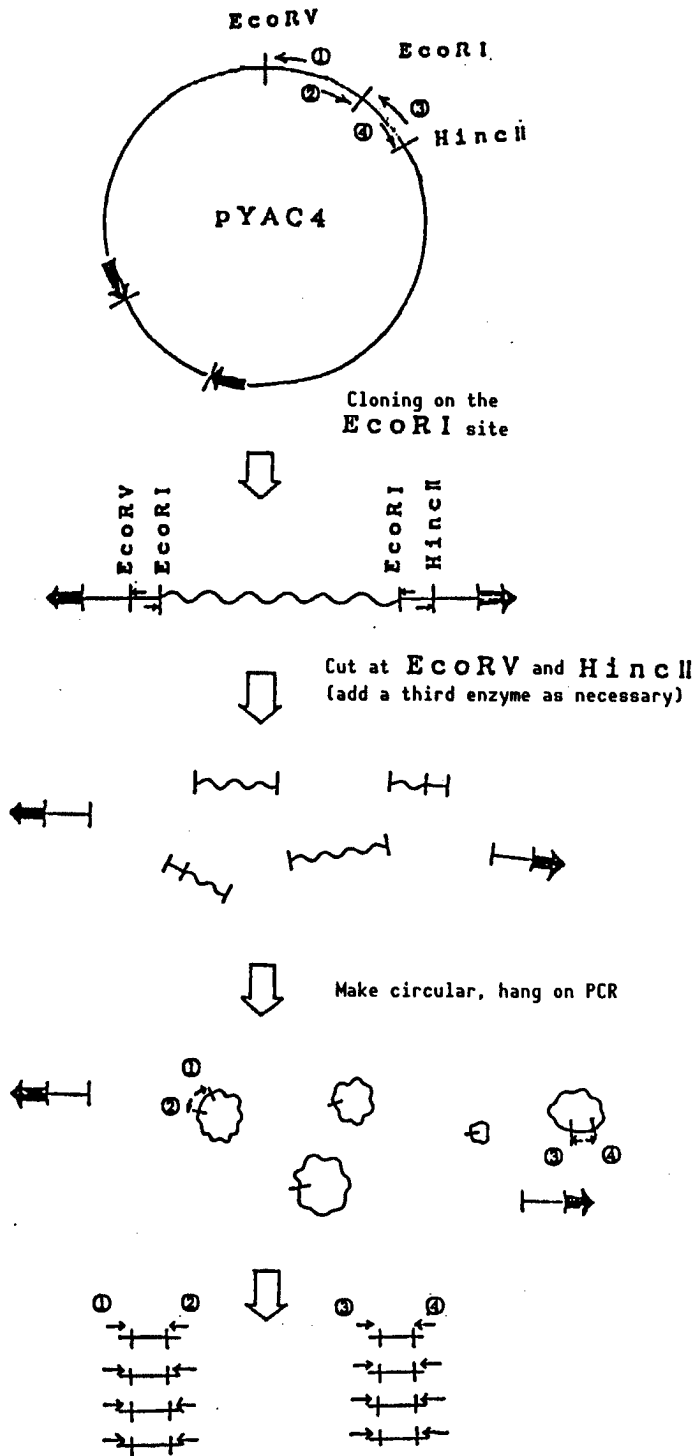

Figure 24.

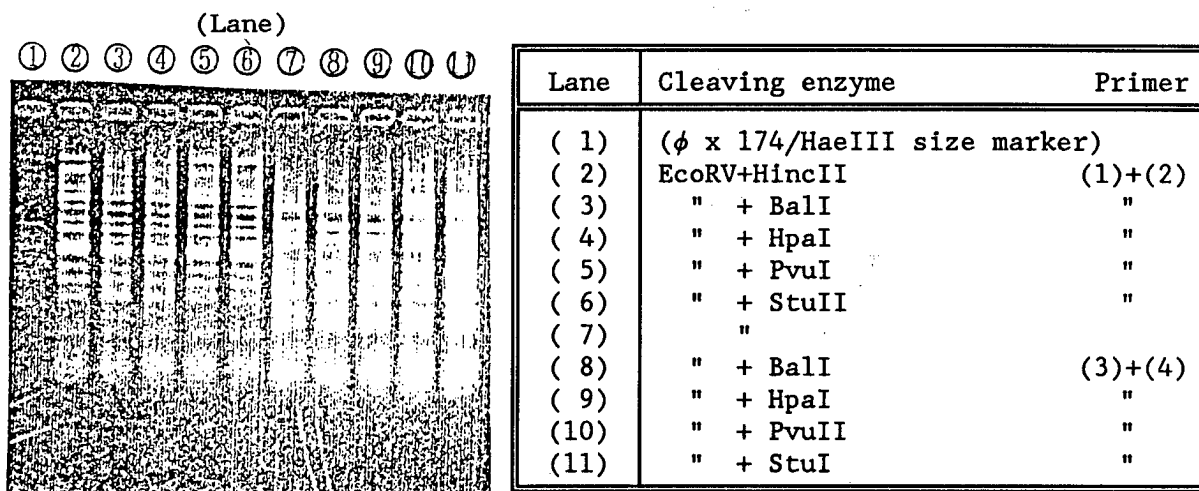

Figure 25.

(5) Plans for further research

Since the ordering method by PCR is more convenient, conditions will be investigated mainly on this method hereafter. Furthermore, by targeting YAC clones containing probes specific to genes on each chromosome, efforts will be made to enhance the efficiency of the subcloning with this method.

(2) Development of Ordering Techniques for Cosmid Clone

(Name and affiliation) Yuh Honjo (Kyoto University)

(1) Object

Research on gene organization: Ordering techniques for cosmid clones are studied and developed as fundamental techniques for analyzing genetic materials.

(2) Summary

To achieve the object described above, this year many cosmid clones derived from the antibody heavy-chain gene regions specific to human chromosome 14 were isolated and development of techniques for ordering among these clones were tried.

(3) Text

(1) Research materials and methods

Cosmid libraries were screened using each gene of human antibody constant (C) region, diversity (D) fragments, and representative genes for each variable (V) family (I-VI) as probes. These genes had already been isolated. To protect form and eliminate the important artifacts of unrelated fragments ligated and

incorporated into clones at the time of library construction, partial fill-in methods were introduced to construct better libraries. From these libraries clones were also isolated using the probes described above.

For easy and rapid ordering for numerous clones isolated, several techniques described below were developed and introduced.

- Techniques that construct both end probes of clones by primer extensions and detect rapidly the duplication of clones.
- Techniques that construct restriction maps easily and promptly using restriction enzymes, so-called rare site cutters, that have an extremely low frequency of recognition sites.
- Techniques that apply the pulsed-field electrophoresis to several kinds of B-lymphocyte cell stocks and assume the order among clones from the deficiency pattern of probe segments.

(2) Research results

Until this year over 100 cosmid clones have been isolated. These clones were subjected to the ordering using the methods described above. The following results were obtained, substantiating the advancement of ordering method:

- V gene located at most downstream was VH-IV and the region from this to JH-C μ gene through D segment groups has been isolated by cosmid clones partially duplicated.
- A part of D segment (D5) existed in the manner falling into V region gene groups.
- Duplications existed over fairly large regions (more than 50 Kb) including D5-V.
- When cosmid libraries were constructed using materials that contained many short DNA segments, clones derived from artifacts were included with fairly high frequency.
- The artifacts described above were very few in cosmid libraries constructed by the partial fill-in method.

(4) Consideration

More rapid analysis of numerous cosmid clones is necessary for analyzing a wide range of gene region, and particularly the ordering method cannot be omitted. Though not a few results were obtained this year, analysis has been slow. Therefore, it is not sufficient to limit to the techniques performed this year; it is necessary to continue the development for a more rapid, easy, and highly reliable method.

The artifacts which appear in cloning can become important problems. In fact, it is clear that such artifacts appear rather often in some cases. Now, however, it is not necessary to be concerned about this obstacle since it has been overcome by the partial fill-in method. The fact that duplication was seen in the wide range of the region indicates the necessity to identify remarkably similar clones and distinguish the differences among alleles (or individual differences). The development of a new ordering method is desirable.

(5) Plans for further research

To carry out more rapid ordering, the macrofingerprint method of identifying the duplication around recognition sites of rare site cutter, a rapid restriction enzyme mapping method using vector probes and partial digestions, and other methods will be developed and introduced.

A new method like two-dimensional pulsed-field electrophoresis will be developed to perform an ordering on the isolated clones or chromosomes of the population, and to be able to analyze from a larger point of view.

2) Development of Mapping Techniques

(1) Physical Mapping With DNA Probes

(Name and affiliation) Yosiyuki Sakaki (Kyushu University)

(1) Object

The object of this research is to develop DNA probes necessary for physical mapping of the wide range of the human genome, especially to develop NotI linking clones and to use both in genetic mapping and the development of needed techniques.

(2) Summary

To construct libraries of NotI linking clones, a method was established for separating effectively linear and circular DNA using a pulsed-field gel electrophoresis. With this method several thousands of NotI linking clones were successfully separated. This method is generally useful for separating DNA segments containing rare cutter sites.

(3) Text

(1) Research materials and methods

Procedures for DNA: Generally Maniatis's method was used.

Construction of HTF library: After completely digesting human placenta DNA with HpaII, segments smaller than 500 base pairs were collected using electrophoresis with 1 percent agarose of low melting points.

These segments were inserted into pUC19 at AccI site and transformed to *E. coli* to construct libraries.

Pulsed-field polyacrylamide gel electrophoresis (PF/PAGE): DNA was charged to 4 percent polyacrylamide gel in the size of 9 cm x 12 cm x 0.9 cm and run with 6.7 V/cm, 15~60 seconds pulse at 10~15°C for 20 hours.

(2) Research results

HTF libraries: Since it was reported that more than 90 percent of NotI site in human genomes are located in HTF island, HTF libraries have been constructed by the method described above. Using 100 µg of human DNA as the starting materials, 30,000~40,000 clones were obtained.

Selection of NotI linking clones: Entire plasmid DNA was extracted from the libraries described above. After digesting them with NotI, linear DNA (digested with NotI) was isolated by the PF/PAGE method. The DNA was circularized with DNA ligases and then transferred to *E. coli*. Approximately 1,000 clones were obtained. Twenty-eight of thirty clones chosen arbitrarily had NotI site. Inserted DNAs in those clones were 50~500 base pairs in size.

(4) Consideration

The PF/PAGE method developed in this study can be generalized as that for selecting cloning the rare cutter site regions with high efficiency. It would be especially effective in the case of that randomness that occasionally remains for the recognition sequence, like SfiI. This method has also several application fields beside the separation of clones.

(5) Plans for further research

Linking libraries of NotI, BssII, and SfiI will be constructed using DNA libraries of human chromosome 21 and 18 as the starting materials. It will be also evaluated whether human L1 retroposon can be used as a probe specific to human genes.

Mapping with the pulsed-field gel electrophoresis will be tried using several kinds of probe DNA isolated in the experiment above. In particular, analyses will be centered in the regions for Alzheimer β-protein genes in chromosome 21 and the region for transsiletin in chromosome 18.

Finding out technical problems through the second experiment, the improvement will be tried on such problems.

(6) Publications

Ito, T. and Sakaki, Y., A novel procedure for selective cloning of NotI linking fragments from mammalian genomes. NUCLEIC ACIDS RES., Vol 16, 1988, pp 9177-9184.

(2) Physical Mapping Using Linking Libraries

(Name and affiliation) Misao Ohgi (Laboratory for Serum Virus, Cancer Research Center of Saitama Prefecture)

(1) Object

The purpose of this research is to construct NotI linking clone libraries derived from human chromosome 21, and NotI physical map by the linking clone methods with these clones.

(2) Summary

The DNA chain length of human chromosome 21 is 48,000 kilo base pairs. As the first step to clarify the structure, the construction was tried for physical maps. As the method for constructing the maps, we constructed linking clone libraries and adopted the method for identifying linking fragments using individual clones. Currently, the libraries are being constructed and the sizes of linking fragments identified. Linking clones with fragment sizes covering 40 percent of the total length of chromosome 21 have been identified. Experiments are progressing satisfactorily and it will soon cover its 80 percent as libraries.

(3) Text

(1) Research materials and methods

For constructing NotI linking clone libraries, random phage libraries containing the chromosome 21 DNA as an inserted segment were used as the starting material. For the selection of clones containing NotI sequences from this library, small DNA segments having *E. coli* Sup F genes were inserted into NotI regions after digestion, and the Sup F gene functions were used as positive markers.

(2) Results

Using the method described above, 330 clones were obtained from *E. coli* libraries of chromosome 21 DNA. Considerable numbers of clones overlapped and there were 138 independent clones. Also from HindIII libraries, 75 independent clones were obtained. Whether or not each clone derived from the chromosome 21 was tested by the Southern hybridization method using DNA of human, mouse, and mouse-human hybrid cells. Also after cloning procedures, it became difficult to distinguish between methylated and nonmethylated NotI sites. Southern hybridization tests were carried out for several kinds of human culture cell DNA, selecting what may be used as linking clones because the NotI sites were open. From the EcoRI and the HindIII libraries, 17 and 10 NotI linking clones were obtained, respectively. NotI linking fragments of 10 clones have been identified using PFG electrophoresis. The chain lengths of the NotI fragments identified were 1 Mb pairs on the average, 4 Mb for longer ones, and 0.1 Mb for shorter ones.

(4) Consideration

About 220 independent candidates were obtained from HindIII libraries of chromosome 21 DNA. Whether they are on chromosome 21 or not was tested and it was found that approximately 60~70 percent of them were derived from the other chromosomes. From Southern hybridization experiments on all culture cell genomes, those having NotI sites that are not methylated and open were half of those identified as derived from the chromosome 21. This is an ineffective experiment in that the majority recovered as phage DNA must be discarded. NotI linking fragments having 40 percent of the total length of the chromosome DNA, however, have been identified with 10 clones identified as NotI linking ones. This indicates that the number of NotI sites in chromosome 21 is fairly less than what was calculated (100~200).

(5) Plans for further research

Determination of the chromosome location of NotI linking clones using the *in situ* hybridization method: Locations on chromosomes of approximate 20 linking clones obtained will be determined using each type of chromosome 21 deficient panel. This experiment has been started already in cooperation with the Chromosome Group of this center. The resolution by *in situ* hybridization is about 10 Mb. With this, data analyses will be easier and the mapping will start on a full scale.

(3) Development and Application of New Methods for Detecting DNA Polymorphism

(Name and affiliation) Takeshi Hayashi (Oncogene Laboratory, National Institute of Cancer)

(1) Object

It is thought that human beings constitute a population that is genetically heterogeneous and DNA base sequences are different among individuals at one site in several hundred base pairs on average. Many such variants, that is, DNA polymorphism, would not be phenotypically detected but inherited according to Mendel's laws. A part of the polymorphism can be detected as the restriction fragment length polymorphism (RFLP) and the locations on chromosomes are determined by the genetic linkage analysis. Currently, linkage maps with 10 cm on average (biological genetic map) have been constructed using RFLP. Also the cloning of the objective genes has been tried using RFLP probes linked to specific genetic diseases. The resolution power, however, has heretofore been inadequate for the linkage maps and DNA regions reached by the so-called "walking" with existing probes are very limited. Therefore, it is necessary to construct more precise linkage maps using more DNA polymorphisms.

Theoretically, RFLP can detect only a part of polymorphisms. Also, extremely complex procedures, such as digestions with several restriction enzymes, preparations of RI labeled probes, and the hybridization using them, are necessary for the detection. This research aims at developing a method for detecting DNA polymorphisms that are completely different from the

conventional ones like RFLP, easy to use in procedures and highly efficient, and capable of constructing precise linkage.

(2) Summary

Single-strand DNA shows movements specific to the base sequences in acrylamide gel electrophoresis. This is because the single-strand DNA in solutions takes on a structure which is dependent on the base sequence. We used this phenomenon and developed a new experimental method capable of detecting single-base substitution in several hundred base pairs of DNA fragments. We named this the SSCP method. Using PCR (polymerase chain reaction), a method (PCR-SSCP method) was also developed for detecting DNA polymorphisms very rapidly, easily, and efficiently. Using this method, it was found that Alu repeated sequences numbering several hundred thousand are known to exist in the human genome and are extremely rich with polymorphisms.

(3) Text

(1) Research materials and methods

Cultured human cancer cells were obtained from the JCRB Cell Bank and ATCC. DNA was prepared by the Blinn & Stafford method (NUCL. ACIDS RES., Vol 3, pp 2303-2308). For SSCP analysis, DNA samples are digested with restriction enzymes and denatured with alkaline or formaldehyde, then separated with 5 or 6 percent polyacrylamide gel electrophoresis with 1xTBE. Targeted sequences were detected by hybridization after electroblotting. For PCR-SSCP analysis, samples were labeled with ³²P-nucleotides or ³²P-primers during PCR reactions and subjected to the analysis. Oligonucleotide primers were synthesized with the DNA synthesizer of ABI Company. For the direct determination of DNA base sequences, the Gyllensten & Erlich method (Proc. N.A.S. USA 85, 7652-765) was used. Data for DNA base sequences were based on the Genbank data base.

(2) Research results

(a) SSCP method

Melanoma cells SK2 and bone marrow leukemia cells HL60 have point mutations on each HRAS gene. From a model experiment using plasmid DNA into which such gene regions cloned from these cells are inserted, it became clear that single-base substitution can be detected by the SSCP method. Furthermore, the same results were obtained from the direct analysis of DNA-extracted cells described above. In the next, it became clear that SSCP can detect all these mutations, as the results of investigation of DNA of several other cells known to have mutations on RAS genes.

(b) PCR-SSCP method

Particular genes in genome DNA can be specifically amplified *in vitro* by using PCR. Labeled products amplified can be obtained using RI-labeled primers or nucleotides during the reaction period. After analysis with the SSCP method, DNA polymorphisms were successfully detected, quickly and efficiently.

With this method, a new polymorphism was found at D13S2, a location on chromosome 13. It was confirmed that this polymorph inherits according to Mendels law.

(c) Polymorphism of Alu repeated sequences

Using the PCR-SSCP method described above, it was found that Alu repeated sequences are extremely rich in polymorphisms.

(4) Consideration

The PCR-SSCP method that we have developed is an epoch-making one that enables us to detect DNA polymorphisms extremely rapidly and efficiently. Furthermore, by the discovery of polymorphisms in Alu repeated sequences, it has become very easy to search the locations of polymorphisms.

(5) Plans for further research

- A method will be established for efficiently determining base sequence around Alu repeated sequences.
- Many regions close to Alu repeated sequences in gene libraries specific to the chromosome 11 will be determined using this method.
- Based on the sequences obtained, oligonucleotides will be synthesized. PCR-SSCP analyses will be conducted for the CEPH family DNA using these as primers, to construct the precise linkage map of this chromosome.

(6) Publications

1. Orita, M., Iwahara, H., Kanazawa, H., Hayashi, K., and Sekiya, T., "Detection of Polymorphisms of Human DNA by Gel Electrophoresis as Single-Strand Conformation Polymorphisms," Proc. Nat. Acad.Sci., USA, 1989, in press.
2. Hayashi, K., Orita, M., Suzuki, Y., and Sekiya, T., "Use of Labeled Primers in Polymerase Chain Reactions (LP-PCR) for a Rapid Detection of the Product." Submitted.
3. Orita, M., Suzuki, Y., Sekiya, T., and Hayashi, K., "A Rapid and Sensitive Detection of Point Mutations and Genetic Polymorphisms Using Polymerase Chain Reaction." Submitted.
4. Orita, M., Iwahana, H., Kanazawa, H., Hayashi, K., and Sekiya, T., "An Efficient Method for Detection of Polymorphisms of Human Genome by Gel Electrophoresis as Single-Strand Conformation Polymorphisms." Presented at the Workshop on Molecular Approach to the Human Genome, 15-19 March 1989, Oiso, Japan.

5. Hayashi, K., Orita, M., and Sekiya, T., "Use of Polymerase Chain Reaction for Rapid and Sensitive Detection of Genomic Polymorphisms." Presented at the Workshop on Molecular Approach to the Human Genome, 15-19 March 1989, Oiso, Japan.

(4) Chromosome Mapping of DNA Clones by *in Situ* Hybridization

(Name and affiliation) Hiroshi Nakai (Faculty of Medicine, Tohoku University)

(1) Object

The object of this research is to develop mapping techniques that are fundamental for analyzing human chromosome DNA.

(2) Summary

DNA clones derived from human chromosomes, including chromosome 21, were collected from inside and outside the country and gene mappings were carried out by *in situ* hybridization techniques, especially highly accurate techniques. Eleven unnamed DNA fragments in total and two kinds of chromosome 21 cDNA were mapped. Foundations were established for further cooperative research with Soeda and Onodera, members of this research group, concerning giant clones of chromosome 21 and cDNA.

(3) Text

(1) Research materials and methods

(a) Unnamed DNA fragments of chromosome 21

Eleven unnamed DNA fragments cloned from mouse fused cells (WA17) that excessively have only human chromosome 21, using cosmid vectors (cooperated with Watkins, et al.).

(b) cDNA of chromosome 21

Two genomes corresponding to the cDNA were taken from gene libraries of human chromosome 21 and separated by a cell sorter, using mouse cDNA libraries, therefore, genes are expressed in mouse tissues, as probes.

According to Zabel, et al., (1983) and Nakai, et al., (1987), experiments were repeatedly carried out and improved. Namely, peripheral blood lymphocytes of normal human males were juvenilized with PHA-M type and cultured in RPMI-1640 medium containing 20 percent fetal bovine serum and streptomycin-penicillin. Three days later Brdu was added to it. After being synchronously cultured at the S stage for one day under shaded conditions, precipitates (cells) were washed with RPMI-1640 alone and then cultured in media containing thymidine. Six hours later they were harvested without colcemid. After hypotonic treatment and fixation with Carnoy's solution, chromosomes were spread on slide glasses. The slide glasses were treated with RNase and hybridized

overnight with tritium (³H)-labeled DNA fragments. The chromosome DNA and the labeled DNA probes were denatured in 70 percent formamide-2xSSC at 70°C and used as single-strand DNA. The DNA was washed three times with 50 percent formamide-2xSSC at 40°C, three times with 2xSSC at room temperature, dehydrated with ethanol solution, dried, and subjected to autoradiography. The autoradiography was kept in a black box for slides for seven to ten days, and latent images were produced in a refrigerator. It was developed, fixed, washed with water, dried, and then kept in a desiccator.

The slides were obtained with Hoechst 33258, irradiated with long-wave ultraviolet for one hour, and stained with Giemsa solution in Sorensen buffer solution (pH 6.8). Bands of chromosome were clearly observed with a green interference filter and silver grains without the filter. Silver grains less than five on chromosomes in one dividing figure in the autoradiography were combined into a total. Silver grains that were not on the chromosome but close to it were included.

(2) Research results

Cells observed were well stretched, mostly in early metaphase, and clearly stained. They were separately stained well and each band was clearly identified. Though some of the subbands were not clear in some cases, localizations of each 21q22.1, 21q22.2, and 21q22.3 in the case of 21q22 region were able to be pointed out in the near, middle, and far localization of the region, respectively. For one DNA fragment, 200-400 cells were counted and specific regions were determined. From this, five unnamed DNA segments in which gene groups related to the expression of the main symptom of Down's syndrome are likely included were detected at 21q22. Furthermore, one expression of DNA purified from chromosome 21 was also detected.

(4) Consideration

Registered numbers of DNA segments derived from chromosome 21 became 113 in the 9.5th International Workshop for the Construction of Human Gene Maps (at New Haven) held in August 1988. After that, the number including cDNA was increased. The localizations of these, are becoming clear by DNA of fused cells, *in situ* hybridization, and linkage analysis. Present mapping is a result that would make research of chromosome-gene structure a trend.

(5) Plans for further research

- Collecting clones, mapping with highly accurate *in situ* hybridization, and increasing its efficiency
- Developing rapid mapping techniques by introducing a picture-analyzing apparatus.
- Establishing mapping techniques for giant DNA clones
- Investigating the *in situ* hybridization and the clinical application of chromosome 21 DNA

(5) Analysis of Transcription Gene (cDNA) and Chromosome Mapping

(Name and affiliation) Kazukiyo Onodera (Faculty of Agriculture, University of Tokyo)

(1) Object

cDNA that is a unit of transcription is isolated in a way specific to chromosomes and the efficacy of the method is investigated. With its mapping on chromosomes, the ordering of each cDNA fragment and the construction of markers on chromosomes are carried out for the analysis of chromosome organization.

(2) Summary

To construct cDNA libraries specific to chromosome 21, three methods were used, that is 1) the phage dot-blot hybridization method, 2) the subtraction method DNA (under investigation), and 3) the single-copy DNA method. The results made clear that cDNA clone specific to chromosome 21 can be efficiently obtained.

(3) Text

(1) Research materials and methods

Cells: CHO; Chinese hamster ovary cell. 2Fu^r; hybrid cells composed of CHO and human lymphocyte cells, containing only the long arm of chromosome 21 as human chromosomes. A9; mouse normal cells. WA17; hybrid cells composed of A9 and human fibroblast cells, containing chromosome 21 as human chromosomes.

(a) Phage dot-blot hybridization method

cDNA libraries were constructed from 2Fu^r cells and cloned to λ gt10 phage. These were amplified to about 10^{10} pfu by two separate steps and dotted on nylon membrane filters using manifolds with 96 holes. These filters were hybridized with the following probes: human repetitious Alu sequence (BLUR 8), repetitious sequence different from Alu sequence (pHRS580), and chromosome 21 segments purified from genomic libraries specific to human chromosome 21 (Ch. 21 DNA).

(b) Subtraction method

cDNA libraries were constructed from WA17 and A9 cells. The cDNA libraries derived from WA17 cells were labeled with ³²P and those from A9 cells with biotin. Both libraries were denatured under conditions of excess of cDNA libraries derived from A9 cells (more than 10 to 1) and then hybridized. After that, the reaction mixture was extracted with phenol. cDNA extracted in waterphase was recovered and cloned to λ gt10 phages.

(c) Single-copy DNA method

High-molecular weight DNA negative clones were isolated from genomic libraries specific to human chromosome 21, using the hybridization method. Human cDNA libraries were screened using these clones as probes.

(2) Research results

(a) Phage dot-blot hybridization method

Table 5. Number of Clones Positive to Each Probe
(Among about 4,000 clones)

	BLUR 8		pHRS580		Ch.21DNA	
	W	S	W	S	W	S
Total	1	17	2	27	13	31

S: Strong signal; W: Weak signal

(b) Single-copy DNA method

From 776 clones of genomic libraries specific to chromosome 21, 163 clones were obtained as clones negative to the repetitious sequence. Among 163 clones, 80 clones were randomly selected and classified, and transcription was observed in 42 clones. Among the 42 clones, 15 were randomly selected and subjected to regional mapping (Table 6).

Table 6. Number of Clones Classified by Each Region on cDNA Obtained

Region	Number of clones
qcen-q22.2	13
p11.2-pcen	1
N.I.	1

(4) Consideration

(a) Phage dot-blot hybridization method

As the results of screening, 48 positive clones were obtained from approximately 4,000 clones randomly selected. From further detailed analysis, it became clear that cDNA clones derived from chromosome 21 can be screened with a rate of one in several hundred clones. This efficiency for screening is 100 to 1,000 times higher than that of the conventional plaque hybridization method. By the calculation based on this result, if cDNA libraries containing approximately 10^6 clones are screened, all cDNA of chromosome 21 would be

cloned with a 1 percent probability error. Though problems remain on the quality of cDNA libraries, this may be an efficient method for obtaining cDNA clones specific to chromosomes.

(b) Single-copy DNA method

Since 776 clones were screened under the assumption that the average size of DNA isolated is 8 kbp without duplication, regions covering approximately 4.6×10^7 bp with 8 kbp x 776 clones have been analyzed. This is equivalent to about 10 percent of chromosome 21. Considering that transcriptions had occurred in 42 segments and half of the clones had not been analyzed in this step, the number of genes on chromosome 21 were approximately 800 by calculation. This number is supposed to be very reasonable. Though cDNA in the region of qcen-q22.2 was obtained with high frequency with this method, it may be because repetitious sequences are biased on the chromosome.

(5) Plans for further research

- A large number of cDNA derived from chromosome 21 will be isolated by the combination of material and method, and the development of efficient methods.
- More detailed regional mapping will be carried out for cDNA obtained. The sequences will be determined and the function of description products will be clarified.

3) Collection of Genetic Materials and Information

(Name and affiliation) Yohji Ikawa, Eiichi Soeda, and Meirim Sarai (Laboratory of Gene Bank, Institute of Physical and Chemical Research)

(1) Object

The purpose of this project is to investigate and prepare the collection and maintenance system for information to support the analysis of human chromosomal DNA.

(2) Summary

(1) Collection and maintenance of genetic materials

Twenty stocks of YAC clones of human chromosome 21 (approximately 100 kbp) were developed. From Professor R. White of the School of Medicine, University of Utah, 175 stocks of human probe DNA were obtained and kept in a gene bank.

(2) Collection and arrangement of DNA clones and sequencing data

The format and data base for sequencing data of human chromosomes including chromosome 21 were constructed and systems were prepared for their use.

(3) Text

(1) Collection and maintenance of genetic materials

From Professor R. White of the School of Medicine, the University of Utah, 175 stocks of human DNA probes were obtained and kept at -80°C after their amplification and inspection. During this period, systems were prepared for collection, maintenance, and transfer of genetic materials and information to support this research project.

YAC vector libraries were constructed from hamster hybrid cells containing chromosome 21. Using repetitious sequences specific to chromosome 21 as probes, 20 stocks of YAC clones containing chromosome 21 were obtained. The average length of DNA cloned was 120 Kb, which accounts for approximately 10 percent of the total length of chromosome 21.

(2) Collection and arrangement of DNA clones and sequencing data

This year, systems composed of Basic Sybyl module and Advanced Computation module, which enable the analysis of data base function and the molecular structure of DNA and proteins, were prepared.

A software that can predict the structure dependent on DNA sequences has been developed and the relationship between DNA sequences and conformations is being analyzed with computers and experiments.

Existing software was improved for predicting the secondary and tertiary structure of proteins, and also for the modeling. As a result, a prospect for steadily predicting the structure change along with replacing sequences using computers has been obtained and quantification is currently being investigated on this prospect.

(4) Consideration

(1) Collection and maintenance of genetic materials

Concerning human DNA probes, they are not only useful for RFLP and VNTR but also for giving basic points on mapping of YAC clones, if they are mapped on chromosomes. This time chromosome 21 probes were only two, including whole chromosomes. Therefore, chromosome 21 probes will be collected using the collection format developed in this research.

Concerning YAC clones, 10 percent of chromosome 21 was collected this time. If about 400 stocks are collected, the connection can be started to form so-called islands.

(2) Collection and arrangement of DNA clones and sequencing data

From recent studies it has been pointed out that the structure of DNA may alter to different configurations like a loop depending on the base sequences, and deeply relate to the function. Analyzing the structure and physical

properties of DNA with computers, we showed that those are dependent on sequences and were able to explain several experimental results.

The techniques for prospecting protein structures have not been advanced yet but the structure change from amino acids substitution could be firmly prospected, and it was actually applied for protein engineering technology.

(5) Plans for further research

- Collection and storage of clones specific to chromosome 21 and DNA probes
- Development of a classification method for YAC clones and construction of a data base for genetic materials
- Construction of Kontigs map
- Construction of human sequencing data base format and investigation of collection methods
- Collection of DNA clones and sequencing data
- Investigation of systems for collecting genetic materials

- END -