

LOAN DOCUMENT

PHOTOGRAPH THIS SHEET

DTIC ACCESSION NUMBER

LEVEL

INVENTORY

DOCUMENT IDENTIFICATION

DISTRIBUTION STATEMENT

H
A
N
D
L
E

W
I
T
H

C
A
R
E

ACCESSION FOR	
NTIS	GRAM
DTIC	TRAC
UNANNOUNCED	<input type="checkbox"/>
JUSTIFICATION	<input type="checkbox"/>
BY	
DISTRIBUTION/	
AVAILABILITY CODES	
DISTRIBUTION	AVAILABILITY AND/OR SPECIAL
A-1	

DISTRIBUTION STAMP

Reproduced From
Best Available Copy

DATE ACCESSIONED

DATE RETURNED

19981223 037

DATE RECEIVED IN DTIC

REGISTERED OR CERTIFIED NUMBER

PHOTOGRAPH THIS SHEET AND RETURN TO DTIC-FDAC

FINAL REPORT

AUC PROGRAMMABLE ATTENUATOR

Contract N62269-74-C-0241

NADC
Tech. Info.

ELECTRONIC COMMUNICATIONS, INC.
A SUBSIDIARY OF NCR



COMMUNICATIONS SYSTEMS
ELECTRONIC SYSTEMS
POSTAL SYSTEMS

ST. PETERSBURG, FLORIDA

800754

FINAL REPORT

July 1974

Contract N62269-74-C-0241

AUCS PROGRAMMABLE ATTENUATOR

Prepared By
Electronic Communications, Inc.
St. Petersburg, Florida

Prepared For
Naval Air Development Center
Warminster, Pennsylvania

TABLE OF CONTENTS

	<u>Page</u>
1.0 <u>INTRODUCTION</u>	1
2.0 <u>PROGRAM DESCRIPTION</u>	2
3.0 <u>RF ATTENUATION</u>	3
3.1 Performance Requirements.....	3
3.2 RF Impedance Considerations.....	3
3.3 Attenuation of PIN Diodes.....	5
3.4 Attenuator Speed.....	8
3.5 Attenuation Variation with Frequency.....	8
3.6 Transmit-Receive Switching.....	12
3.7 Miniaturized RF Circuitry.....	12
3.8 Final RF Section of the Breadboard Attenuator.....	13
4.0 <u>DRIVER CIRCUITRY</u>	26
4.1 Interface Requirements.....	26
4.2 Development of Driver Circuitry.....	26
4.3 Driver Circuit Time and Temperature Stability.....	29
4.4 Miniaturized Driver Circuits.....	29
4.5 Final Breadboard Driver Circuit.....	30
5.0 <u>PACKAGING</u>	32
5.1 PIN Diode Mounting.....	32
5.2 RF Considerations.....	32
5.3 Driver Considerations.....	32
5.4 Final Breadboard Package.....	33
5.5 Improvements of the Attenuator Package.....	33
6.0 <u>CONCLUSIONS</u>	36

LIST OF FIGURES

	<u>Page</u>
1. Constant Impedance Attenuator Circuits.....	4
2. Attenuator modified to present a High Impedance to the Load.....	6
3. Table of PIN Diode Parameters.....	7
4. Modified Bridge "T" Attenuator.....	9
5. PIN Diode Equivalent Circuit.....	10
6. Resonating PIN Diode Capacitance.....	11
7. Schematic of Final Breadboard Attenuator.....	14
8. Calculated Resistance Variation of Shunt and Series Diodes versus Attenuation for 50 ohm Input Z.....	15
9. Breadboard Attenuator Impedance Measurements 1.....	16
10. Breadboard Attenuator Impedance Measurements 2.....	17
11. Attenuation versus Frequency Characteristics of the Breadboard Attenuator.....	18
12. Attenuation Drift with Time for the Breadboard Attenuator.....	19
13. Power Dissipation and Frequency Variation Test Data for Breadboard Attenuator.....	20
14. Harmonic Output and Switching Time Test Data for the Breadboard Attenuator.....	21
15. Unitrode 7006 PIN Diode Resistance versus Bias Current at UHF Frequencies.....	23
16. Harmonic Power Measurements of a Single Diode Test Circuit.....	25
17. Forward Bias Attenuator Driver Circuit.....	27
18. Constant Current Attenuator Driver Circuit.....	28
19. Controls and Connections of the Breadboard Attenuator.....	31
20. Photograph of the Breadboard Attenuator.....	34
21. Photograph of the Breadboard Attenuator Interior...	35

1.0 INTRODUCTION

NADC recognized that the versatility of the Navy's overall Multiplatform Transceiver could be enhanced by including an electronically programmable attenuator for covert communications operation. Such an attenuator could limit the transmitted power to the minimal level necessary for communications between two or more locations. NADC also recognized that system complexity and cost could be minimized by including the programmable attenuator in the transmit/receive switch presently intended for the transceiver. ECI was selected by NADC to study the feasibility of an electronically programmable attenuator using PIN diodes as the controlling elements.

In the course of this effort various circuit configurations for PIN diode attenuators and diode drivers were investigated. Tests were conducted on these circuits and the results reported monthly throughout the program. After studying the results of these tests and studying the electrical design goals, a breadboard programmable attenuator was constructed. Tests conducted on the breadboard have confirmed that an electronically programmable attenuator is feasible for operation in UHF transceivers.

Various problems and operational limitations were investigated during this program. Most of these problems were resolved by trade-offs made to reduce the effects on overall performance. The most significant of these problems were harmonic output at high attenuation settings and the ability of the attenuator to maintain the desired attenuation as frequency and temperature is varied. Electrical parameters such as VSWR, attenuation stability, harmonic output, switching speed, isolation, and frequency response, can be adjusted for a particular requirement as trade-offs are made to reduce circuit complexity and cost.

Consideration was also given to thermal problems and packaging approaches. Thermal problems do not exist with large packages but if the package size is reduced, a heat sink must be provided to dissipate the heat from the attenuator. The breadboard attenuator was constructed with discrete components to facilitate testing; however, Micro-min circuits could be used to significantly reduce the size of the unit. Additional study into Micro-min packaging of the programmable attenuator could result in improved performance, smaller size, and minimum cost for high quantities.

2.0 PROGRAM DESCRIPTION

This report documents the investigation, construction and test of a programmable RF attenuator. The attenuator regulates UHF Transmitter output power to the minimum required for secure communication. Attenuation levels are in discrete steps which are electrically selected by digital signals from a separate control unit.

This investigation was to study the feasibility of an electronic programmable attenuator and to determine its operating characteristics and limitations.

A number of technical characteristics needed definition. The required thermal dissipation was not known. The switching speed was a function of diode size, but how this affects the operation of an attenuator was not known. The attenuation range, flatness with frequency, insertion loss and interface requirements required definition for proper specification of a realizable attenuator.

After the operating parameters were determined a model attenuator was needed to demonstrate the capabilities defined during the investigation phase. The model was to be suitable for further laboratory evaluation and capable of performing the functions of both an attenuator and a transmit-receive RF switch.

This report details three main topics pertaining to the attenuator. They are: RF attenuation, driver circuits, and packaging. Expansion of these topics include basic requirements of each, investigations, and design of the engineering breadboard. Conclusions and recommendations follow the basic text.

3.0 RF ATTENUATION

3.1 Performance Requirements

Design goals were set to describe the specific electrical requirements for a programmable attenuator. The most important of these were:

- Operating Frequency - 225 to 400 MHz
- Power Handling - 100 watts (at minimum attenuation setting)
- Transmit to Receive Isolation - 25 dB
- Antenna to Receive Insertion Loss - 0.3 dB
- Transmit to Antenna Insertion Loss - 0.3 dB
- Transmit Port VSWR - 1.2:1
- Receive Port VSWR - 1.2:1
- Switching Time
 1. Transmit to Receive - 100 μ s
 2. Receive to Transmit - 10 μ s

Besides the basic electrical specifications, a number of general characteristics were desired. The RF attenuator was to be as simple as possible for simplification of the driver circuit design. Components in the RF signal path were to be minimized to reduce insertion loss, and power dissipation was to be low for simplicity of cooling and packaging.

3.2 RF Impedance Considerations

Constant input impedance over the entire range of attenuation and frequency is required to maintain proper loading of the power amplifier driving the attenuator. Many attenuator circuits maintain a constant input impedance for different attenuation levels (Figure 1). The programmable attenuator has an additional impedance requirement. The

A) "T"

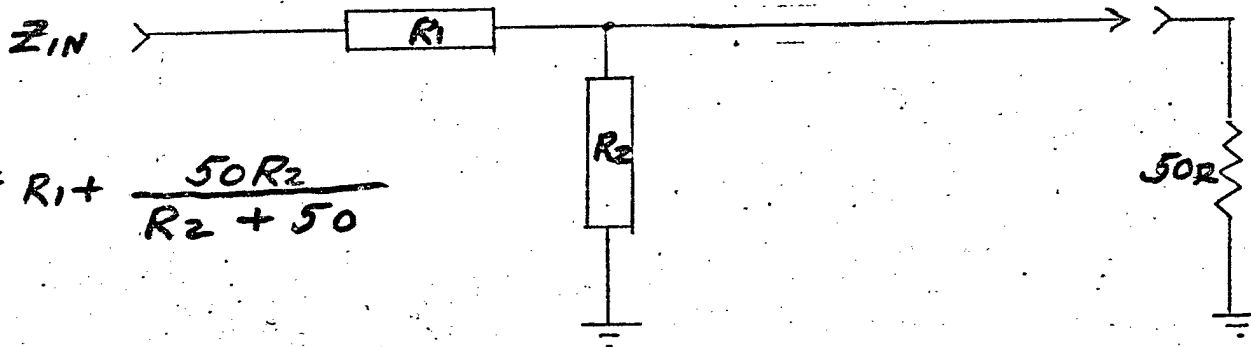

$$Z_{IN} = R_1 + \frac{50R_2}{R_2 + 50}$$

B) "π"

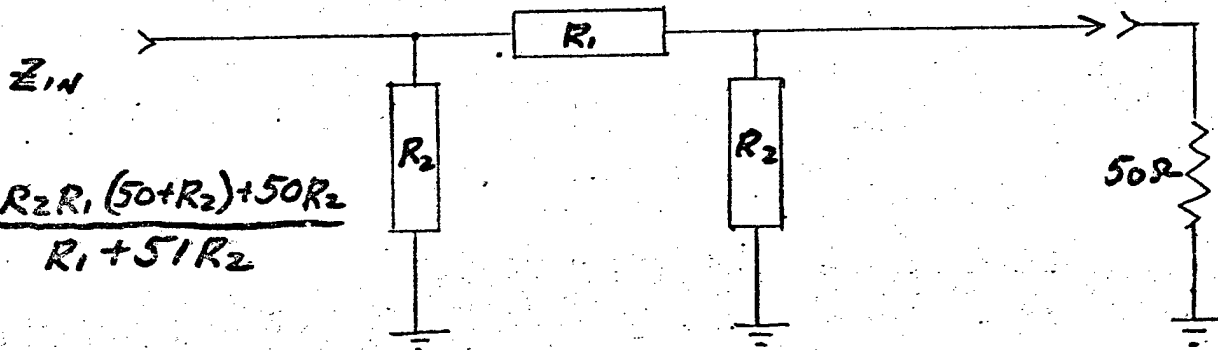

$$Z_{IN} = \frac{R_2 R_1 (50 + R_2) + 50 R_2}{R_1 + 50 R_2}$$

C) BRIDGE "T"

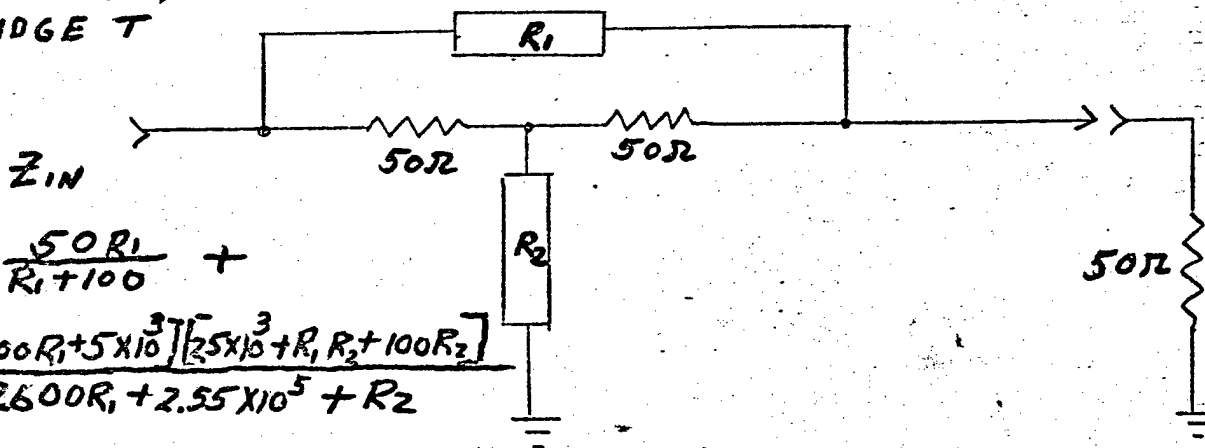

$$Z_{IN} = \frac{50R_1}{R_1 + 100} + \frac{[100R_1 + 5 \times 10^3][25 \times 10^3 + R_1 R_2 + 100R_2]}{2600R_1 + 2.55 \times 10^5 + R_2}$$

FIGURE 1

CONSTANT IMPEDANCE ATTENUATOR
CIRCUITS

3.2 - Contd.

impedance presented to the antenna port must be high when the attenuator is in receive mode. This is to prevent loading of the receive signal. There are a number of ways to do this, such as adding another diode in series with the attenuator circuit (Figure 2) or designing the attenuator to have constant input impedance and an output impedance which increases with attenuation. Designing the attenuator for high output impedance at high attenuation has the advantage of simplifying RF circuitry for this type application. This is not considered a major problem if the antenna impedance is primarily resistive.

The impedance presented to the receiver does not have to be maintained at 50 ohms when the attenuator is in the transmit mode. In the receive mode, the receive port should connect to the antenna unattenuated and with a low input VSWR. A simple switch consisting of a PIN diode provides such characteristics when the amount of required transmit mode attenuation is not more than 15 dB. This is approximately the limit of isolation obtainable from a single series power PIN diode.

3.3 Attenuation of PIN Diodes

The limiting factors of diode attenuation range are diode capacitance and series resistance. Typically, diodes having high on-to-off ratios have high shunt capacitance. A power PIN diode has inherently more shunt capacitance and lower switching speed (see Figure 3). For dissipation capability of 10 to 20 watts and any combination of capacitance, resistance, and on-to-off ratio, a best case attenuation range of ≈ 15 dB in a 50 ohm system is obtainable with a single diode.

The programmable attenuator has a minimum attenuation design goal of 20 dB. This was considered sufficient for secure voice operations. For 20 dB attenuation, the attenuator needs as a minimum, two PIN diodes, one shunt, one series (Figure 1A). Such an attenuator can be biased to provide a constant input impedance, but the output impedance approaches some small value ($\ll 50$ ohms) as the attenuation is increased.

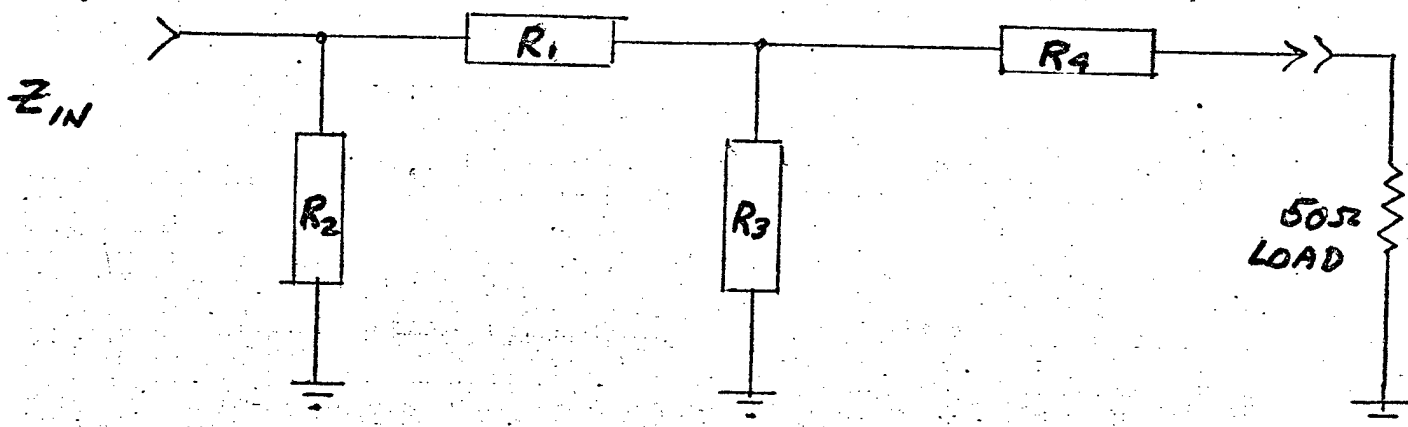

$$Z_{IN} = \frac{R_2 [R_1 (R_3 + 50R_4) + R_3 (R_4 + 50)]}{(R_2 + R_1) (R_3 + 50R_4) + R_3 (R_4 + 50)}$$

$$\frac{V_o}{V_{IN}} = \frac{50R_3}{(R_1 + R_3)(R_4 + 50)}$$

FIGURE 2

ATTENUATOR MODIFIED TO PRESENT
A HIGH IMPEDANCE TO THE LOAD

Diode Number	Total Capacitance	Series Resistance (100 mA)	Carrier Lifetime	Remarks
Unitrode UM 7000	0.9 PF	1.0 ohms	2.5 μ sec	Type used in Attenuator
Unitrode UM 7200	2.2 PF	0.2 ohms	1.5 μ sec	Same size as above diode
Unitrode UM 4900	3.0 PF	0.5 ohms	5.0 μ sec	Higher power rating than UM 7000 series
HP 5082-3080	0.4 PF	2.0 ohms	2.0 μ sec	Gen. purpose low power diode
HP 5082-3202	0.32 PF	0.8 ohms	0.01 μ sec	High Power diode
HP 5082-3003	0.3 PF	1.5 ohms	0.01 μ sec	Low Power diode
Micro. Assoc. MA-47084	3.0 PF	\approx 0.5 ohms	15.0 μ s	High Power diode

FIGURE 3

Table of PIN Diode Parameters

3.3 - Contd.

To minimize the dissipation requirements of the PIN diodes, a fixed resistor can be added to the basic design (Figure 4). When the attenuator is in maximum attenuation mode, the resistor absorbs the incident power. Also, over the attenuation range the first series diode does not dissipate more than half the incident power. Lower dissipation allows the use of smaller series diodes having higher switching speed.

3.4 Attenuator Speed

The switching speed of a PIN diode is limited by the minority carrier lifetime of the diode and the speed of the driving circuit. Drive line bypass capacitance is needed for RF isolation. By keeping the bypass capacitance to a minimum, the effects on driver speed can be reduced. The minority carrier lifetime then has the most effect on switching speed. The larger the diode, the slower the switching speed, because more time is needed to recombine minority carriers. This effect is not easily controlled. Large diodes are necessary for power handling, but for higher switching speed small diodes must be used. Any means such as splitting and combining, adding fixed resistors, or lowering incident RF power will allow the use of smaller diodes resulting in faster switching.

3.5 RF Attenuation Variation with Frequency

The impedance of a PIN diode is not constant with respect to frequency. PIN diodes are represented by a model consisting of series lead inductance, capacitance, and variable resistance (Figure 5). The inductive and capacitive components are responsible for attenuation variation with frequency. Lead inductance can usually be kept small by proper circuit layout. At 225 to 400 MHz lead length in excess of 1/8 inch (≈ 1 to 2 NH) is significant. Diode capacitance is more difficult to control. The intrinsic capacitance of the diode generally increases with the size, power dissipation, and minimum series resistance. Any relaxation of these requirements can be traded for lower diode capacitance. The remaining capacitance can often be resonated with added circuit inductance to form a low pass network (Figure 6), or incorporated in the circuit so that it will not affect the band of interest.

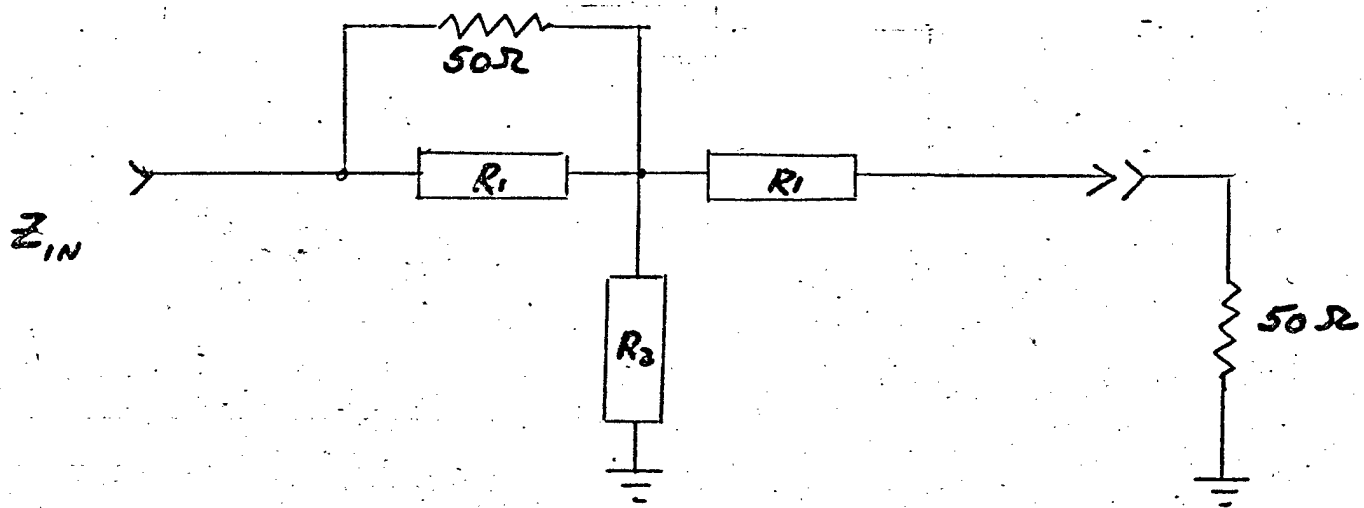

$$Z_{IN} = \frac{R_1 R_2 + 50R_2}{R_1 + R_2 + 50} + \frac{50R_1}{50 + R_1}$$

$$\frac{V_o}{V_{IN}} = \frac{50R_2}{50R_2 + R_1 R_2 + 50R_1}$$

FIGURE 4

MODIFIED BRIDGE "T" ATTENUATOR

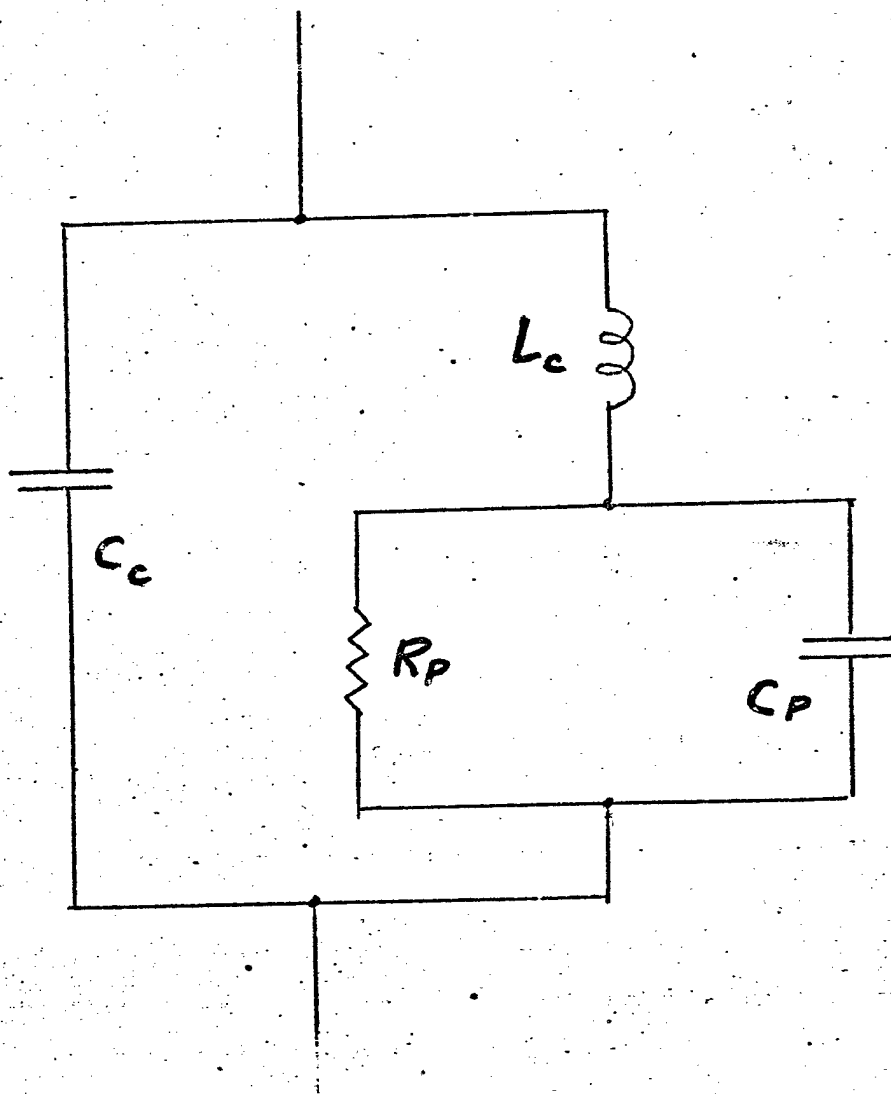

CASE CAPACITANCE - C_c

CASE INDUCTANCE - L_c

PARALLEL RESISTANCE - R_p

PARALLEL CAPACITANCE - C_p

FIGURE 5

P.I.N. DIODE EQUIVALENT CIRCUIT

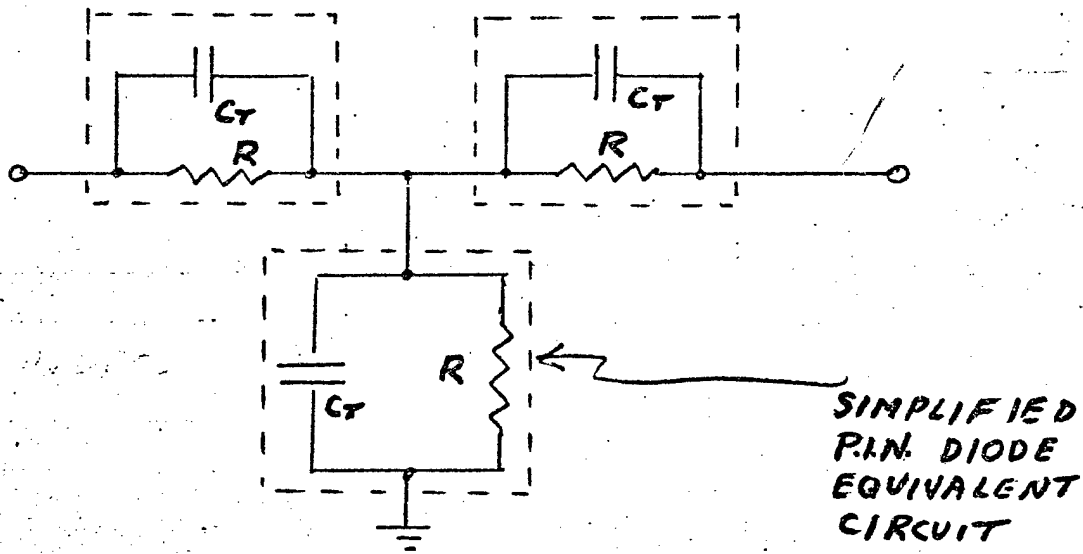

A.] P.I.N. DIODES IN "T" CONFIGURATION

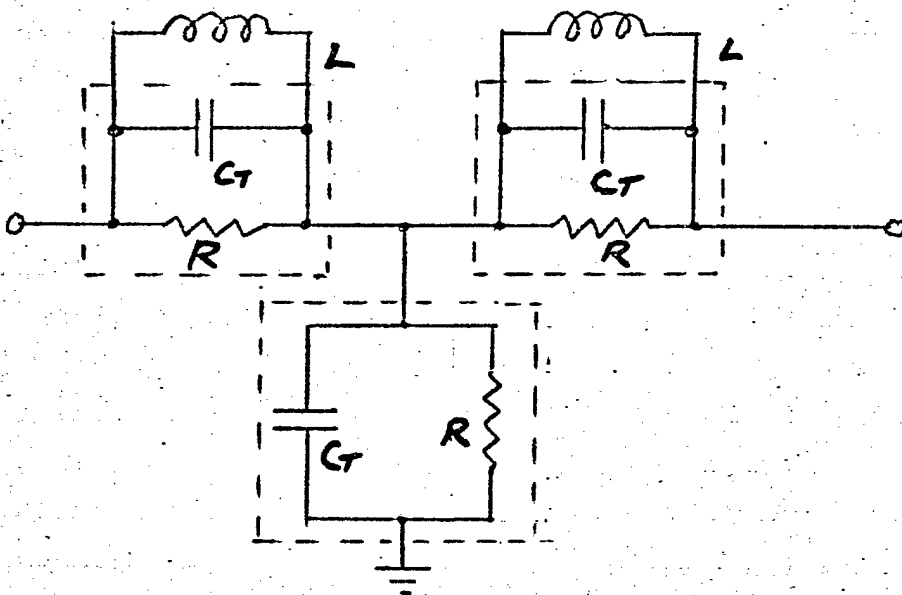

B.] INDUCTORS ADDED TO PRODUCE AN ATTENUATOR OF LOW PASS FILTER FORM.

FIGURE 6

3.5 - Contd.

Signals with frequency periods on the same order of magnitude as the minority carrier lifetime of the diode do not pass without some rectification and production of harmonic products. For PIN diodes, this frequency is usually much less than the frequency of operation and rectification is usually not a problem.

3.6 Transmit-Receive Switching

To switch the antenna port to a third port for signal reception, another PIN diode switch section is necessary. The complexity of this switch is dependent on the amount of isolation necessary to protect the receiver from the high RF power of the Transmitter. Receiver inputs of from 10 to 100 milliwatts can usually be tolerated without special protection depending on the design of the receiver front end.

Addition of a shunt diode on the receiver input or on the receive port of the attenuator can increase the receive isolation by 20 to 30 dB.

When the antenna switches to the receive port, the transmitter port must be isolated from the antenna port. To accomplish this the attenuator between the transmitter and receive port must present a high impedance to the antenna port. For a constant impedance attenuator, this can be done by adding an additional diode in series between the antenna port and the attenuator or the attenuator can be tailored to present a high impedance to the antenna and a constant impedance to the transmitter port.

3.7 Miniaturized RF Circuitry

The limit on size reduction is set by thermal requirements, and the availability of miniature components capable of withstanding RF levels of 10 watts or more.

PIN diodes capable of dissipating several watts are available in chip form, but the manufacturers do not guarantee the dissipation performance if not bonded to a package by them. Some investigation and evaluation of bonding power PIN diodes directly to a hybrid substrate is needed before a practical hybrid attenuator can be built.

3.7 - Contd.

Other components required for the attenuator i.e. capacitors and inductors are available in forms suitable for hybrid design and capable of handling moderately high power. With hybrid construction it is possible to reduce the size of the attenuator to about 1/2 to 1/10 the volume of a discrete attenuator.

3.8 RF Section of the Final Breadboard Attenuator

The final RF breadboard was designed and built to meet the specified performance goals utilizing the simplest and most economically compact, discrete component, construction technique available. To maintain a constant input impedance, the attenuator was designed with a modification of the bridge "T" attenuator. This modification allows constant input impedance with a high output impedance at maximum attenuation (Figure 7). The tracking of the series and shunt diodes is made easier by calculating the required impedance for each attenuation setting with constant input impedance (Figure 8). The calculations show that the shunt and series diode current are close to inversely proportional for constant impedance. This means that the input impedance remains fairly constant if both the shunt and series impedance are varied the same (linearly) but out of phase. The shunt diode is biased on as the series diode is biased off. The input impedance and attenuation range is controlled by setting the shunt diode turn-on point and adjusting the maximum shunt diode current. This simple alignment method maintains the VSWR at less than 1.5:1 over all conditions. Further improvement can be made by resonating the intrinsic and stray reactances in the attenuator.

Tests of the attenuation range, insertion loss, and port isolation gave acceptable results (Figure 9 through 14). The receive port isolation was not much greater than 20 dB at any point in the 225 to 400 MHz band. The amount of isolation obtained was as expected from one diode with large capacitance and high power handling capability. Additional isolation may be obtained by installing a shunt diode at the receiver input port.

FIGURE 7
SCHEMATIC OF
FINAL BOARD
ATTENUATOR

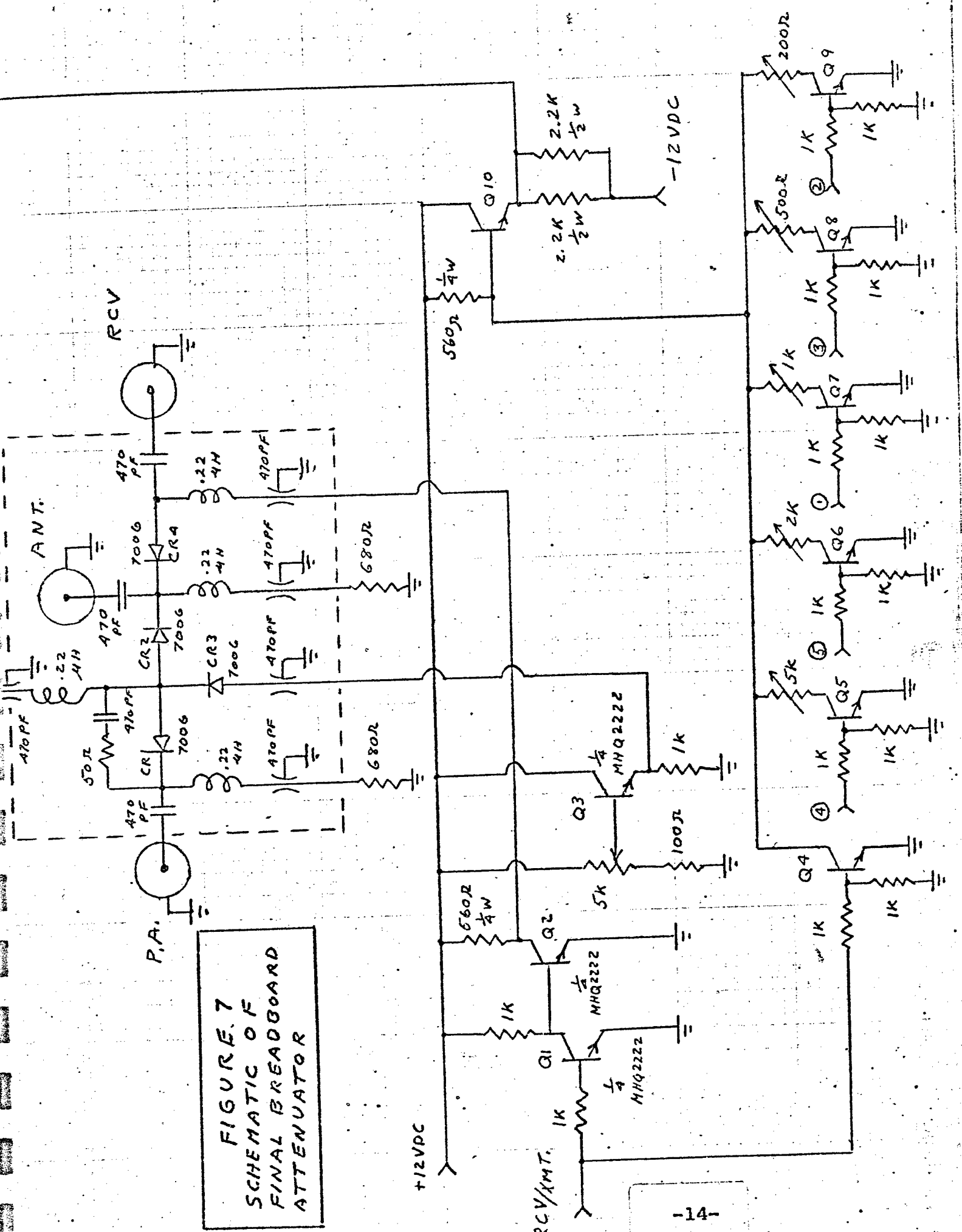

$Z_{in} = 50\Omega$

ATTENUATOR
CONFIGURATION

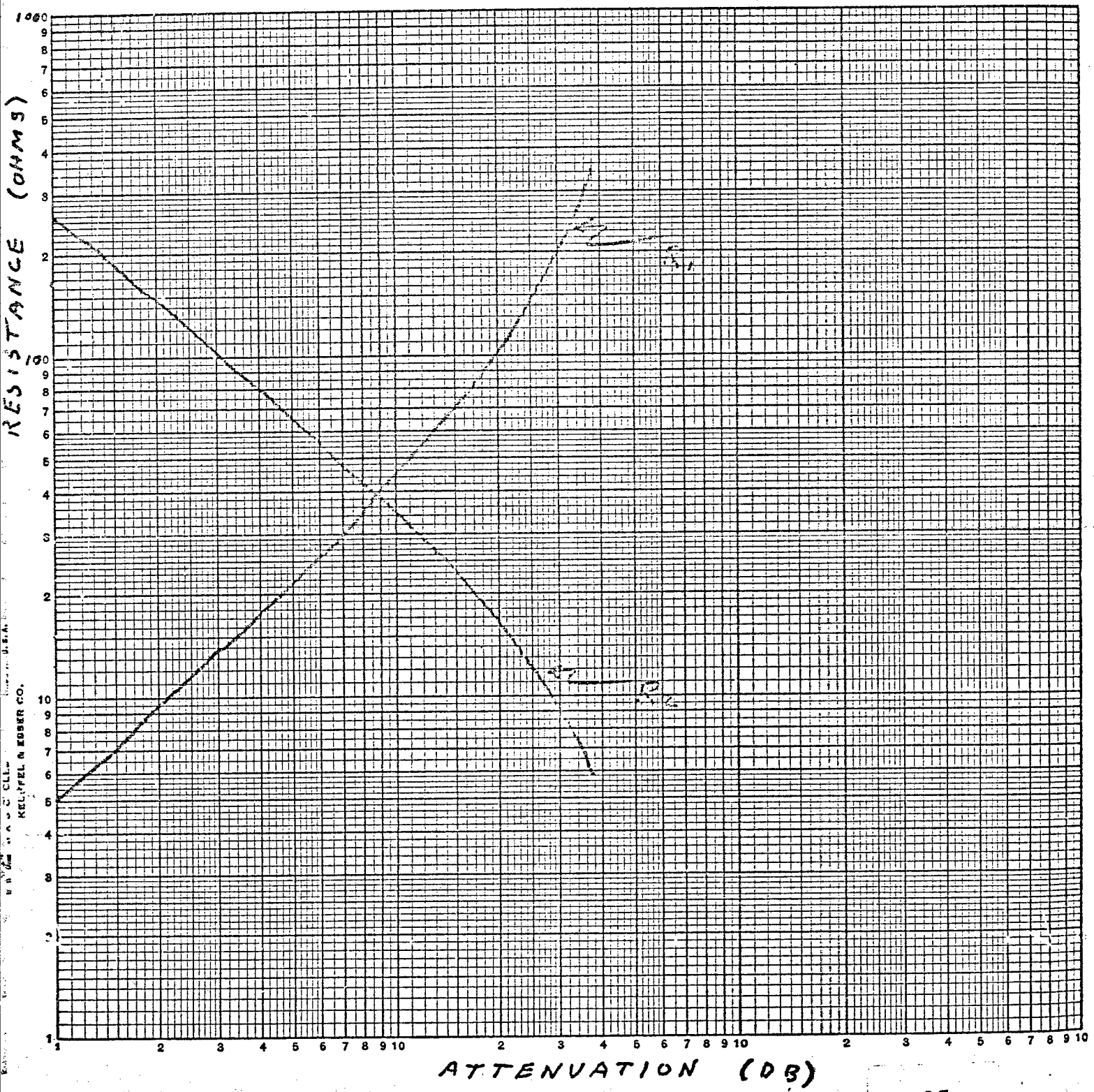
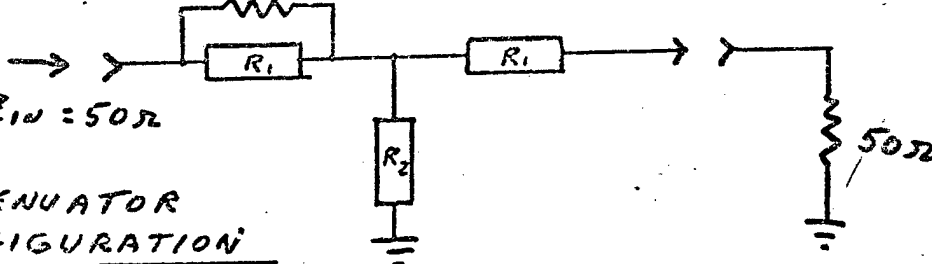
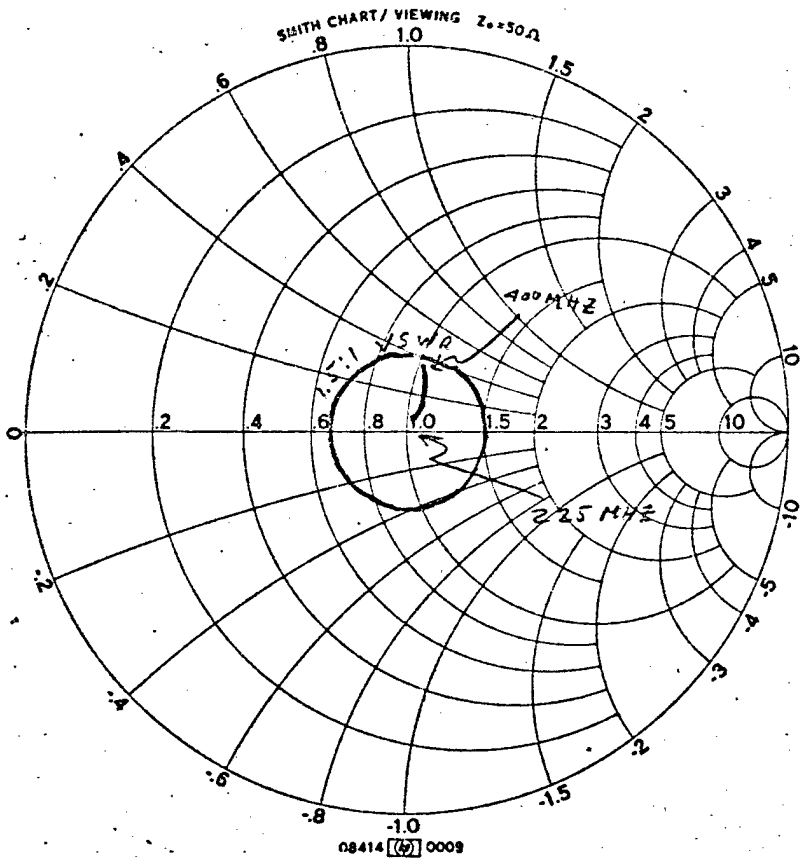

FIGURE 8

CALCULATED RESISTANCE VARIATION OF SHUNT AND SERIES DIODES VS ATTENUATION FOR 50Ω INPUT Z



LEVEL — +10 DBM

FREQ. — 225 TO 400 MHz

PORT — P.A.

ATTENUATION — MIN.

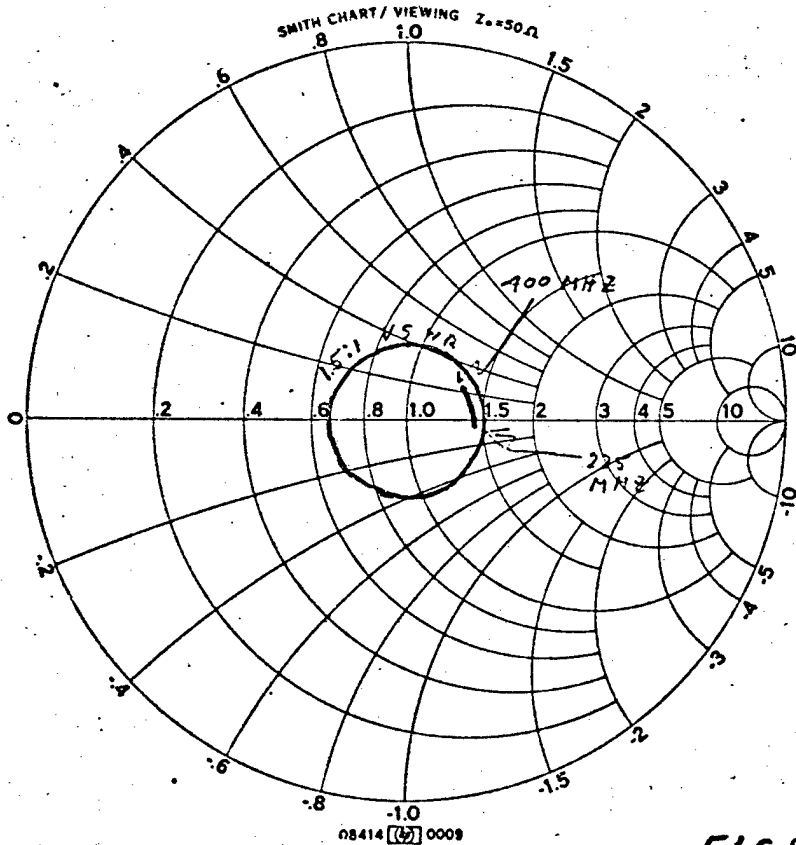

LEVEL — +10 DBM

FREQ. — 225 TO 400 MHz

PORT — P.A.

ATTENUATION — MAX.

FIGURE 9

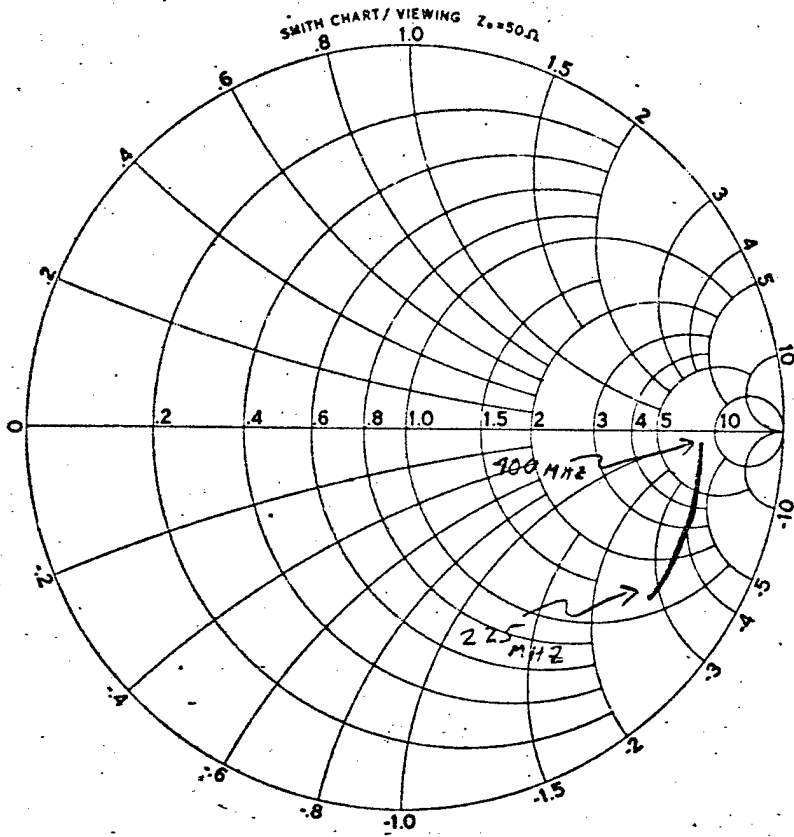

LEVEL - +10 DBM

FREQ - 225 TO 400 MHz

PORT - ANTENNA

ATTENUATION - MAX.

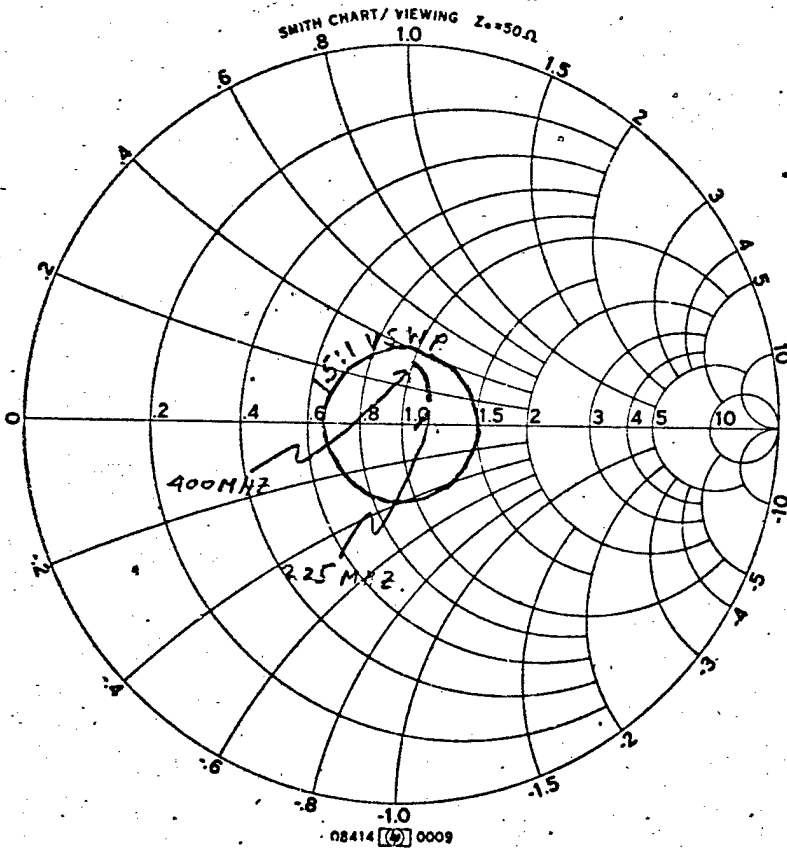

LEVEL - +10 DBM

FREQ - 225 TO 400 MHz

PORT - RECEIVE

ATTENUATION - MIN.
(REV. MODE)

FIGURE 10

Port From	Port To	Atten. Status	Freq. (MHz)				
			225	275	325	375	400
PA	Ant.	Min. Atten.	0.38	0.40	0.38	0.43	0.40
Ant.	Rcv.	Min. Atten.	0.29	0.31	0.27	0.33	0.25
PA	Ant.	Max. Atten.	38	36	34	32	31
Ant.	Rcv.	Min. Atten. PA to Ant.	24	22	21	19.2	19.8

} Atten. (dB)

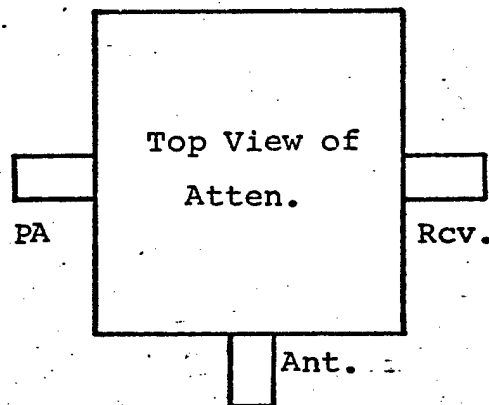

FIGURE 11

Attenuation versus Frequency Characteristics
of the Breadboard Attenuator.

Atten. Setting (-dB)	Power In (Watts)	Test Time (Minutes)	Power Out (-dB from Input)	Remarks
8	10.0	Turn on	- 7.9	
"	"	5 Min.	- 8.0	
"	"	10 "	- 8.0	
"	"	30 "	- 8.0	
15	10.0	Turn on	-15.0	
"	"	5 Min.	-14.5	
"	"	10 "	-14.5	
20 dB	10.0	Turn on	-20.0	Excessive Drift
"	"	1 Min.	-15.1	
25 dB	10.0	Turn on	-24.0	
"	"	5 Min.	-25.0	
"	"	10 "	-25.0	

FIGURE 12
Attenuation Drift with Time
for the Breadboard Attenuator

Port From	Port To	Atten. Status	Time (Hrs.)	Power In (Watts)	Power Out (Watts)
PA	Ant.	Min. Atten.	Turn on	100	93.3
PA	Ant.	Min. Atten.	1 Hr.	100	94.4

Power Dissipation Test @ 300 MHz
of Breadboard Attenuator

Atten. Setting - (dB)	Power In (Watts)	Freq. (MHz)				
		225	275	325	375	400
≈10.0	10.0	-10.4	-10.5	-10.5	-10.1	- 9.9
≈25.0	10.0	-27.0	-25.9	-24.6	-24.5	-24.0

PA to Ant. Atten.

Attenuation Variation with Frequency
of Breadboard Attenuator

FIGURE 13

Power Dissipation and Frequency Variation
Test Data for Breadboard Attenuator

Port From	Port To	Input Level dBm	Atten. Status - (dB)	Level $2f_0$ Below Input - (dB)	Remarks
PA	Ant.	+ 40	8	-54	Varying Level
"	"	"	15	-55	
"	"	"	20	---	
"	"	"	25	-57	
"	"	+ 50	Min.	-54	

Measurement of Harmonic Products of Breadboard Attenuator at Various Attenuation Settings

Port From	Port To	Input Level (dBm)	Switching States	Switching Time (μ s)	Freq. (MHz)
PA	Ant.	+ 40	Min. to Max.	5	300
PA	Ant.	+ 40	Max. to Min.	5	300

Measurement of Worst Case Switching Speed of Breadboard Attenuator

FIGURE 14

Harmonic Output and Switching Time Test Data for Breadboard Attenuator

3.8 - Contd.

Measurement of attenuation variation with frequency showed that for small attenuations (-10 dB) the amplitude ripple across the 225 to 400 MHz band is on the order of 1 dB. For large attenuation settings (-10 dB), the effect of diode capacitance is sufficient to cause a large variation of attenuation (Figure 13). resonating the diode capacitance with parallel inductance minimizes this affect but complicates attenuator tuning.

The attenuation stability is acceptable for both large and small attenuation settings. For intermediate attenuation (15 to 20 dB) the stability may not be sufficient for some applications. This is due to the dependence of the attenuation on small bias currents. When the change in resistance of the series or shunt PIN diodes has an appreciable affect on the diode attenuation

$$\left(\text{i.e. } \frac{\% \Delta R_{\text{diode}}}{\Delta \text{Attenuation (dB)}} \cong 10 \frac{\%}{\text{dB}} \right),$$

the diode bias current must be much larger than the diode rectification current, larger than the change in current due to change in forward diode voltage, and, greater than 1% of the maximum forward diode current. With small diode currents, the changes due to circuit and diode time and temperature variations cause significant attenuation changes (≈ 3 dB) (Figure 15).

When the attenuator attenuation increases, the harmonic content of the attenuated signal increases. The increase in harmonic power is not significant for most applications. Measurement of the second harmonic output of the attenuator with an incident power of 10 watts shows increases typically from ≈ -70 dB with no attenuation to ≈ -55 dB below the input signal with full attenuation (Figure 14).

The amount of harmonic power relative to the incident 10 watts did not change appreciably this implied that the harmonic power was not produced or enhanced by the attenuator diodes but simply passed through by the diode shunt capacitance.

RESISTANCE (OHMS)

KEUFFEL & ESSER CO.

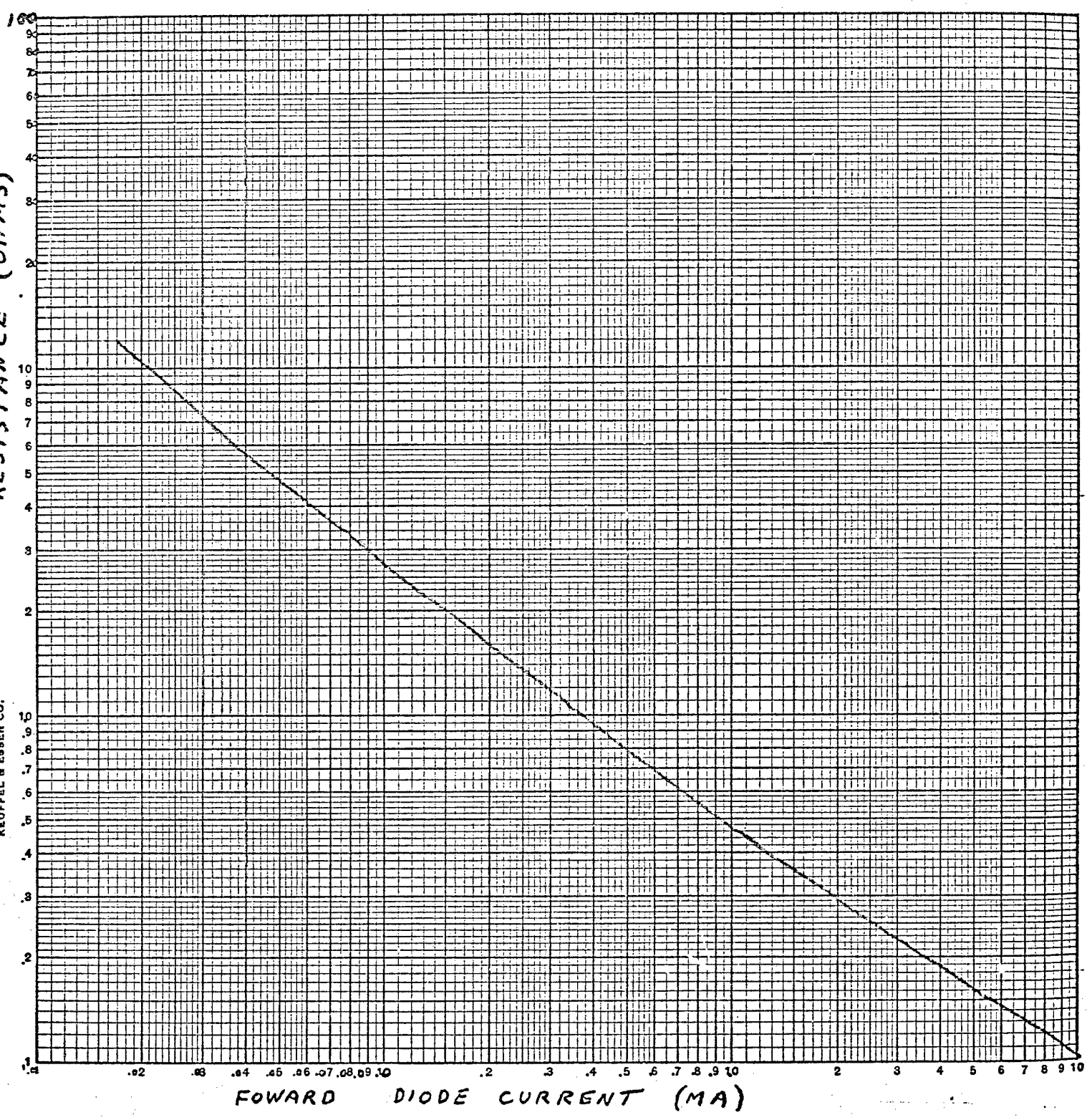

FIGURE 15

UNITRODE 7006 P.I.N. DIODE RESISTANCE VS BIAS CURRENT AT UHF FREQUENCIES

3.8 - Contd.

To test this hypothesis a single PIN diode was tested. Using a signal source with low harmonic content, a diode was set at various series attenuation settings (Figure 16), and the harmonic content of the output measured. The amount of harmonic power increased relative to the f_0 output power and incident power as the attenuation was increased. The greatest increase occurred when attenuations changes from minimum (lowest resistance) to 3 dB (equal to load resistance) attenuation. The PIN diode was not a perfectly linear resistance at UHF frequencies.

Other than the stability and harmonic limitations mentioned, no difficulties were encountered with the remaining design goals. Switching speed, attenuation range, power handling capability, and VSWR were within acceptable limits.

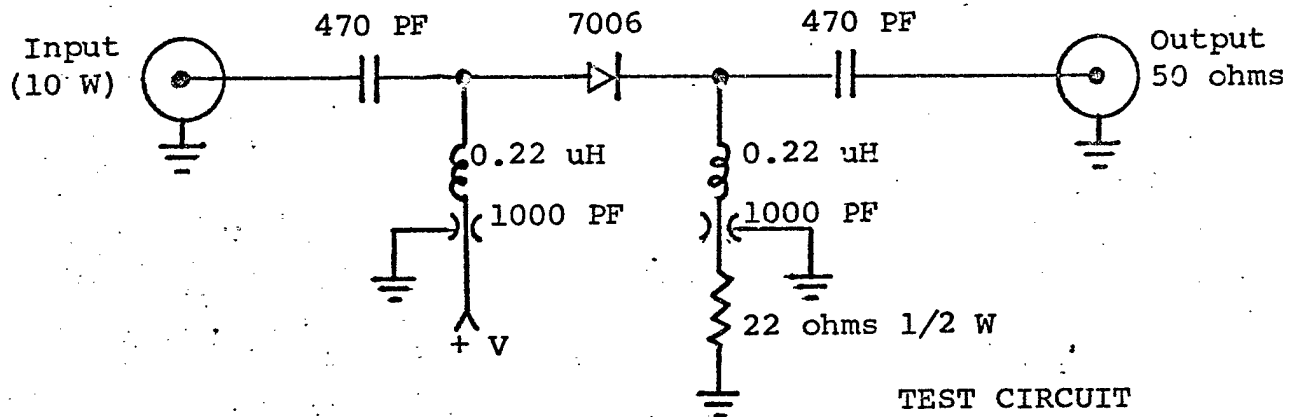

(Harmonic output given in dB below input signal)

Atten. Setting →	Min. Atten.		3 dB		10 dB		Max. Atten.	
	2f ₀	3f ₀	2f ₀	3f ₀	2f ₀	3f ₀	2f ₀	3f ₀
Freq. → 225 MHz	> -60	> -60	-49	-56	-45	> -60	-45	-57
250 "	> -60	> -60	-47	-57	-45	> -60	-45	-56
275 "	> -60	> -60	-50	> -60	-46	-58	-46	-55
300 "	> -60	> -60	-50	> -60	-46	-56	-46	-54
325 "	> -60	> -60	-52	> -60	-47	-54	-47	-53
350 "	> -60	> -60	-52	> -60	-47	-53	-47	-53
375 "	> -60	> -60	-53	> -60	-48	-53	-48	-52
400 "	> -60	> -60	-55	> -60	-50	-54	-50	-52

FIGURE 16

Harmonic Power Measurements of a Single Diode Test Circuit

4.0 DRIVER CIRCUITRY

4.1 Interface Requirements

Ideally a programmable attenuator should be directly addressable by a digital code delivered in parallel binary format. The number to line drive logic is not considered to be a part of the attenuator. The attenuator programmable inputs are designed as lines switchable from off to on by going from a low to high logic state (≈ 0 to 4 VDC). Each line addresses one specific attenuator setting or switches the attenuator from transmit to receive.

The driver circuit must translate the logic level into the proper amount of current and voltage bias for each attenuation setting and maintain the bias over time and changing ambient conditions.

4.2 Development of Driver Circuitry

Reverse bias of PIN diodes was necessary in the past to insure high enough isolation and to prevent diode breakdown. With many PIN diodes available today, it is possible to isolate high power RF signals without reverse biasing. The need for reverse biasing makes driver circuitry complex. A simple circuit such as shown in Figure 17 can drive an attenuator from a single voltage. The major drawback to this circuit is the high current requirement in the low attenuation mode. This occurs because Resistor R1 must be small enough to insure that the current through the shunt diode will not raise the potential across the series diodes to 0.6 VDC.

A more complex constant current driver in conjunction with other voltage sources (Q_1 and Q_2 in Figure 18) overcomes the dissipation problem by reverse biasing the series diodes in the maximum attenuation mode. The disadvantage of this circuit is the complexity. The number of semiconductors involved makes time and temperature stability difficult to maintain.

By using a negative and positive supply voltage, the driver circuit can be simplified to a configuration which provides some reverse bias without additional circuit complexity. This compromised driver circuit is limited in ability to provide high bias current to the shunt diode independent of the turn on point of the diode (i.e. ≈ 100 mA).

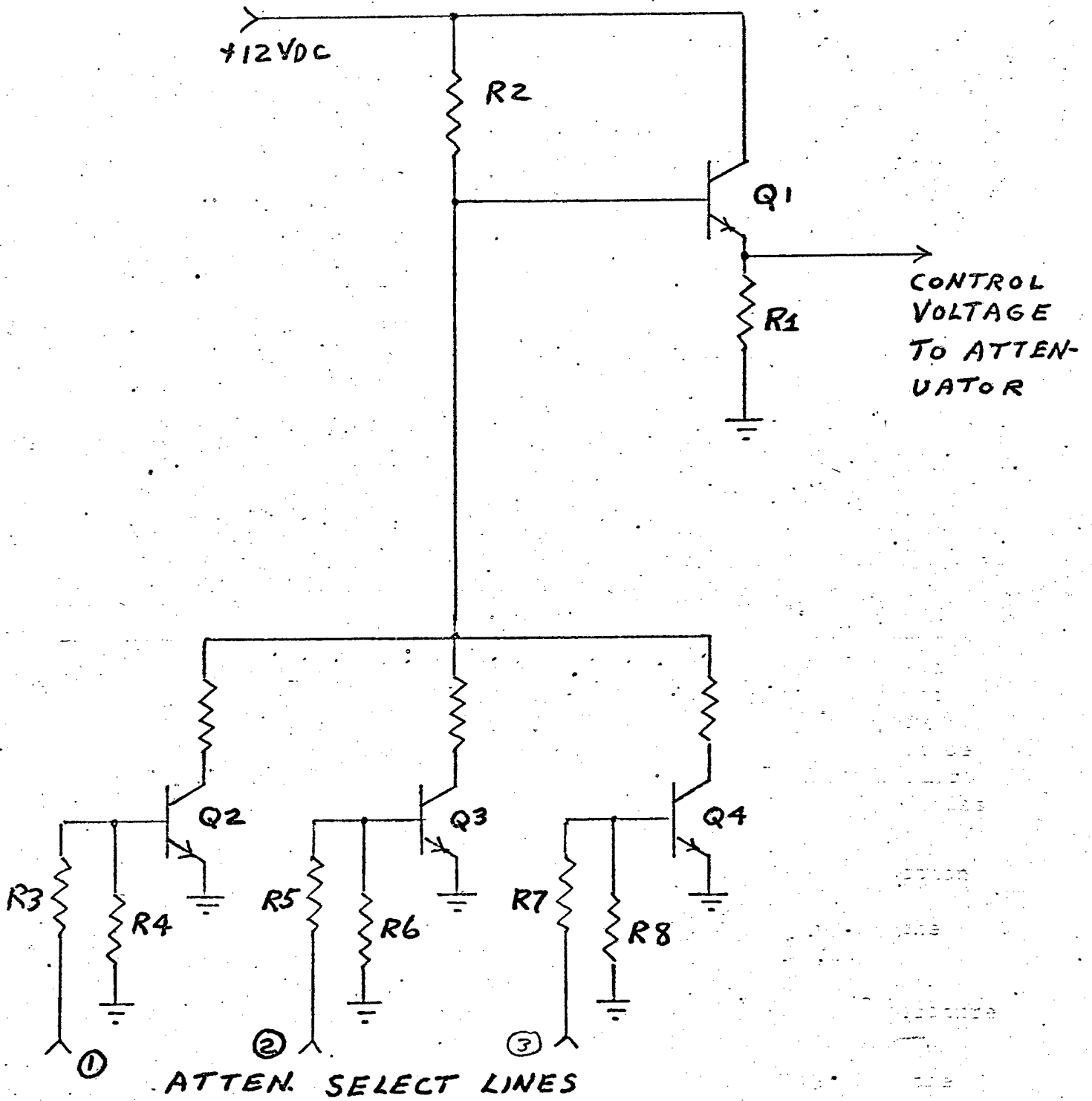

FIGURE 17

FORWARD BIAS ATTENUATOR DRIVER CIRCUIT

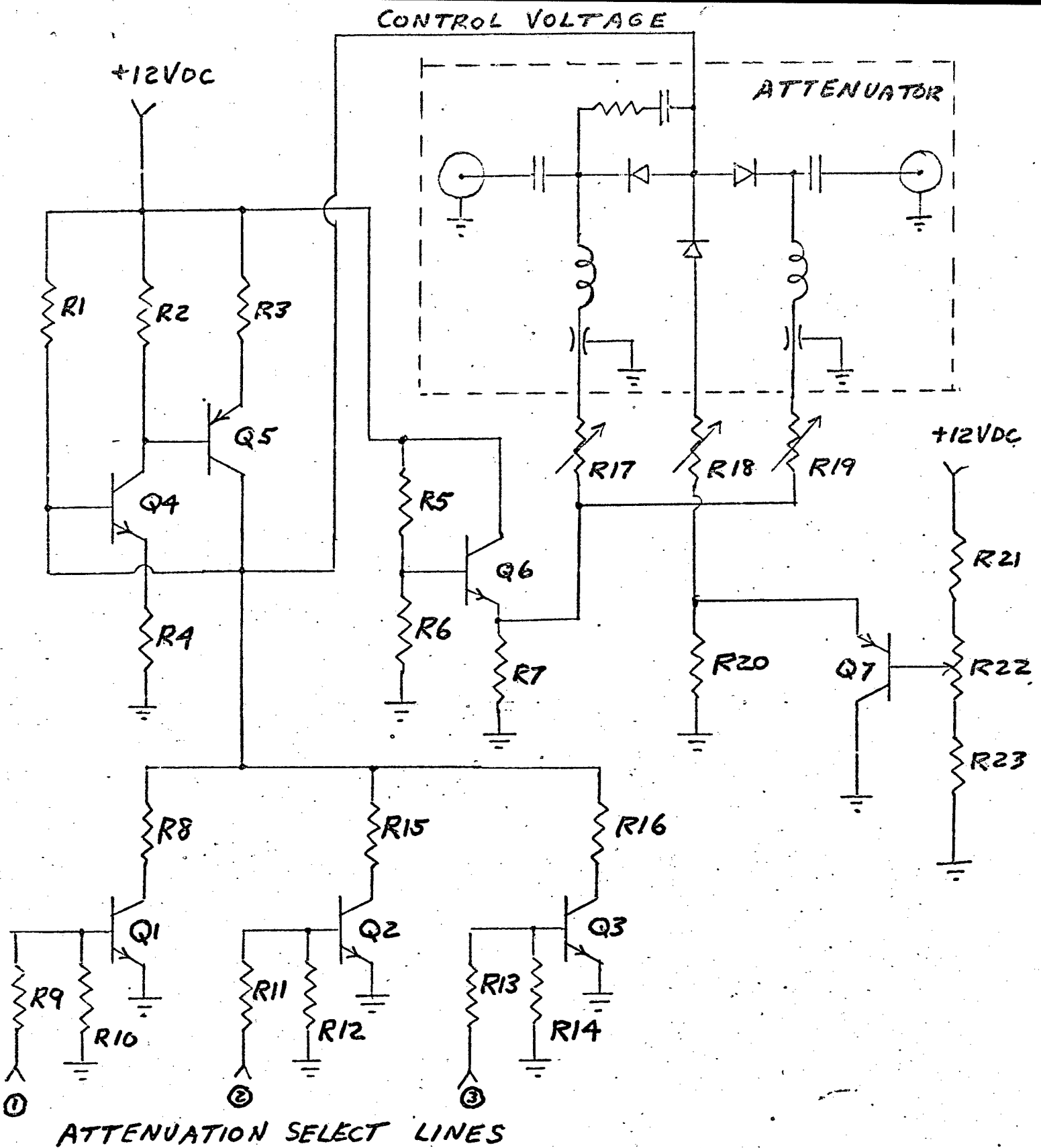

FIGURE 18

CONSTANT CURRENT ATTENUATOR DRIVER CIRCUIT

4.3 Driver Circuit Time and Temperature Stability

The attenuator driver must provide stable current and voltage over a wide range of temperature and long time periods. Attenuation will vary otherwise. The amount of attenuator variation depends on the percentage change of current and voltage applied to the attenuator diodes. Differential change of diode resistance with bias current increases as the diode current decreases. The most difficult diode operating point to maintain over time and temperature is the small current condition (i.e. ≤ 1 mA). As can be seen by Figure 15, there is a large variation in diode impedance as the diode current varies from 0 to 1 mA. If a simple voltage source resistor arrangement is used to bias the diode, a small variation in diode drop can result in a large diode impedance change. The diode forward voltage typically varies 2.0 mV . If incident power raises the temperature or if ambient temperature varies then the diode impedance varies. Attenuation stability at specific settings over a large temperature range can be a troublesome design problem if not recognized.

4.4 Miniaturized Driver Circuits

Because the driver circuit consists primarily of semiconductors and resistors it is readily reduced in size by being built as a hybrid or possibly as an integrated circuit. The limiting factor is power dissipation. The current required to bias the PIN diodes is on the order of 100 mA for a specific supply voltage; the amount of power dissipated in the driver circuit as a minimum would be, $P_{\text{driver circuit}} = (V_{\text{supply}} - V_{\text{diodes}})I_{\text{diodes}} + P_{\text{logic stages}}$ where V_{diodes} is typically 0.6 VDC. The $P_{\text{logic stages}}$ is usually negligible when compared to the total driver power. This power is dissipated either in circuit resistance or in semiconductors. Lower supply voltages would lower the circuit dissipation but make the PIN diode bias potential (≈ 0.6 VDC) a significant percentage of the total supply voltage which makes control of voltages and diode currents more temperature dependent.

Discrete driver circuitry occupies approximately 2 to 3 times the volume of the attenuator. An integrated circuit performing the same function would take about 1/6 the volume of a discrete driver, assuming adequate heat sinking.

4.5 Final Breadboard Driver Circuit

The driver circuit designed for the final breadboard is a compromise between the simple single polarity approach and the two polarity approach (Figure 7). Positive and negative current is supplied to the attenuator. The PIN diode current for the series and shunt diodes is supplied by the positive supply. The negative supply is used as a bias supply for the driver transistor Q10. Using a negative supply reduces the dissipation requirements on R4 to manageable levels (-0.5 w). The higher total supply voltage (24 VDC) also improves the current stability through the diodes by making the diode drop a smaller percentage of the available voltage.

Digital interface to the driver transistor is implemented by logic compatible switching transistors (Q4 through Q9) which set the base voltage of Q10, the PIN diode drive transistor. A positive voltage of approximately 1.2 to 5 VDC on any of the switching transistor base leads will set up an appropriate bias voltage on the emitter of Q10 and therefore, a current through CR1 and CR2. Shunt diode CR3 begins to turn on when the emitter voltage of Q10 drops below the emitter voltage of Q3 minus the diode voltage drop. Connections and adjustments for the driver circuit are shown on Figure 19.

The stability of this driver circuit is acceptable but improvement could be made in delivering low bias currents. A temperature stabilized operational amplifier makes a more stable current source when biased with precision resistors. The cost of a more elaborate driver may be higher than desired for a throwaway module.

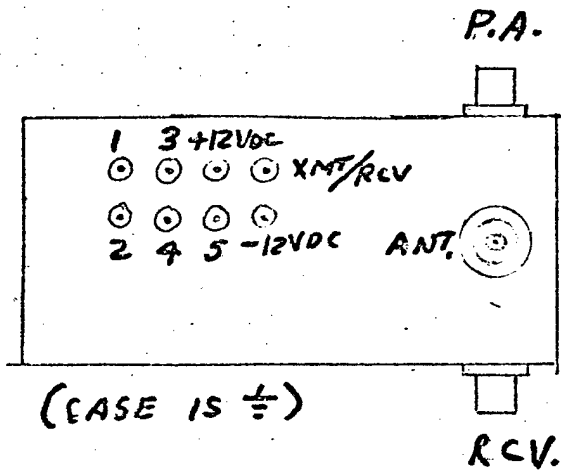

PIN NUMBERS
CORRESPOND TO
ATTEN. SETTING
POTS.

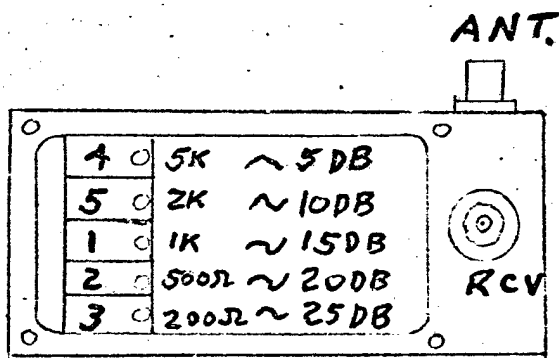

ATTEN. SETTING POTS.
(COVER OFF)

FIGURE 19

5.0 PACKAGING CONSIDERATIONS

5.1 PIN Diode Mounting

The attenuator package must carry away the power dissipated by the PIN diodes. The diodes are designed to dissipate power in excess of 5 watts and must be mounted to a heat sink. This is usually accomplished by a threaded stud or flanges on the diode package. To get the heat away from the diodes, the diodes must be connected to the attenuator and the package mounted to a heat sink. This presents a problem with stud mounted diodes because if the stud protrudes through the package wall, then the package cannot be fastened to an external heat sink without the diode studs interfering. Mounting the diodes on an inside wall would suffice if the thermal gradient of the wall is small.

5.2 RF Considerations

To minimize RF loss and increase isolation, the dimensions of the RF circuitry should be as small as possible. With discrete components the minimum attenuator size is limited by the size of the components. This means that the RF performance of a discrete attenuator is generally not as good as a physically smaller circuit built with hybrid components. A smaller hybrid attenuator would have lower lead inductance and lower shunt capacitance. The package must provide a good common ground for input, output, and control lines. The cover and seams of the package should be sufficiently close fitting to contain RF radiation. RF gaskets can be used if necessary. Package material would preferably be solderable to facilitate bonding of tuning elements and bypass capacitors. Wall thickness is of minor importance unless the power diodes must use the walls as a thermal path.

5.3 Driver Considerations

The driver circuit should be electrically isolated from the RF attenuator circuitry. A conductive wall facilitates bypassing and eliminates capacitive coupling. The driver circuitry dissipates enough power to warrant heat sinking if a supply voltage in excess of 20 VDC is used. Diode currents of typical 0.1 amps will easily produce 2 or more watts of drive circuit heat. Other than size and heat dissipation the driver circuit does not dictate any major additions to the overall attenuator package.

5.4 Final Breadboard Package

The final package is a milled brass block with sheet metal covers over the circuit cavities (see Figures 20 and 21). All wall thicknesses are 0.125 inches which is necessary to carry the diode heat to an external heat sink. The RF circuits are mounted in one end of the case with feedthrough capacitors, and dump resistor soldered to the case between the RF circuit and the driver circuit. The series diodes CR1 and CR2 are mounted to the inside wall by their studs, and coaxial connectors are mounted one on each outside wall. Feedthrough capacitor interconnect the RF and driver circuits through the inside wall. The driver circuit is mounted on a double clad PC board suspended in the package by spacers mounted on one cover. Approximate overall dimensions for the attenuator excluding the connectors are 1.25" x 1.25" x 2.75".

5.5 Improvement of the Attenuator Package

The breadboard attenuator package could be reduced in size by a factor of 3 primarily by miniaturizing the driver, and attenuator circuitry. Milling the package from brass is adequate for small quantities. For large quantity production, a casting would lower cost. Wall thickness can be reduced if the diodes are mounted to the outside wall of the package. Connections through the package to the driver circuit should be made by feedthroughs. A connector would increase the overall size of the package by at least 1/3.

INTERIOR OF
BREADBOARD
ATTENUATOR

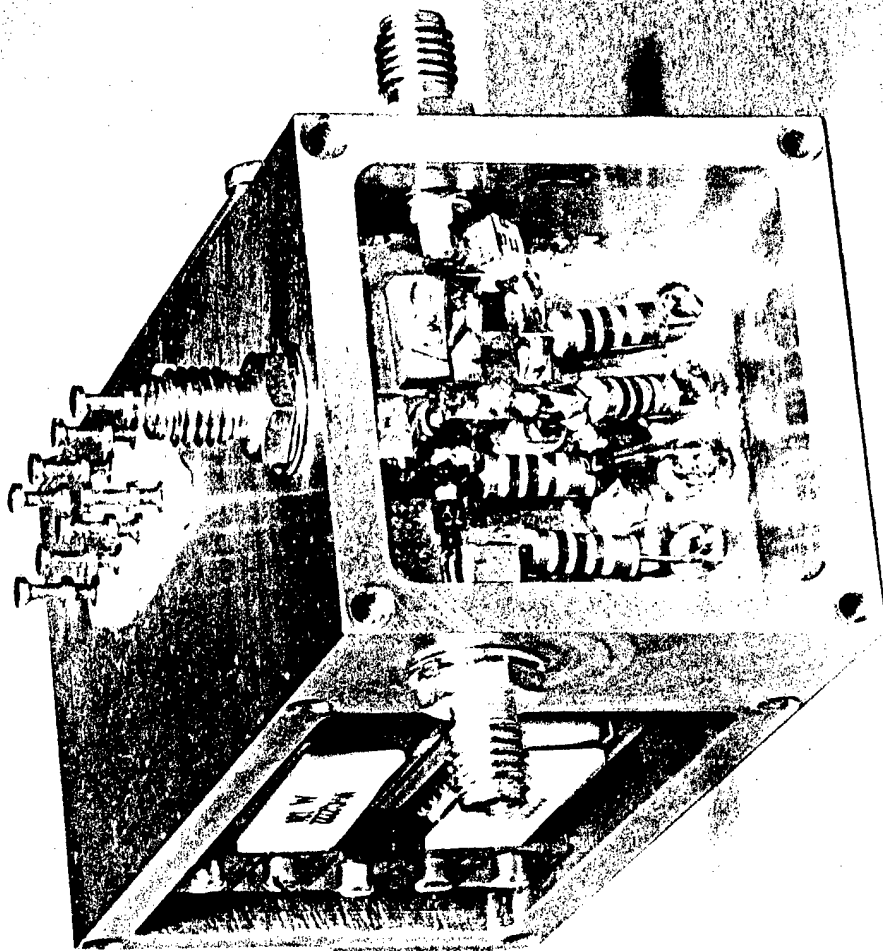

SPE - 154

BREADBOARD
ATTENUATOR

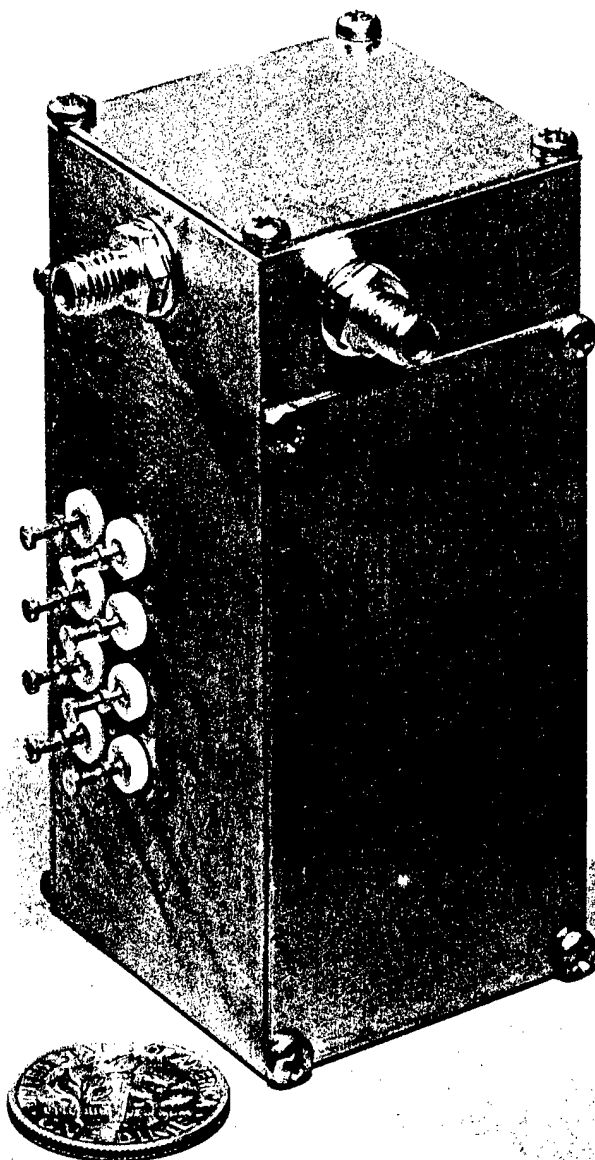

SPE-154

6.0 CONCLUSIONS

The concept of using PIN diodes as variable attenuator elements is promising. However, there are some basic design limitations summarized by the following:

- a) The PIN diodes produce some harmonic power. Harmonics can be filtered or allowed to pass, depending on the application.
- b) Attenuator setting stability is controlled by the stability of the driving source and the characteristics of the PIN diodes.
- c) For up to 10 dB of attenuation range, good setability is attainable with a simple attenuator configuration. Higher attenuation ranges are practical with more complex attenuators.
- d) The frequency response of PIN attenuators must be tuned to optimize attenuation flatness and VSWR.
- e) Simple driver circuits suffer from high dissipation, high diode current variation and poor temperature stability, but all of these factors can be improved by increased circuit complexity.

The final configuration, selected for a particular application, would be suited to Hybrid Micro-min Packaging Techniques for low cost batch processing in production quantities.