

LOAN DOCUMENT

	DTIC ACCESSION NUMBER		PHOTOGRAPH THIS SHEET																					
		LEVEL		INVENTORY																				
DOCUMENT IDENTIFICATION																								
DISTRIBUTION STATEMENT																								
<table border="1"><tr><td colspan="2">ACCESSIONED BY</td></tr><tr><td>NTIS</td><td>GRAM <input checked="" type="checkbox"/></td></tr><tr><td>DTIC</td><td>TRAC <input type="checkbox"/></td></tr><tr><td>UNANNOUNCED</td><td><input type="checkbox"/></td></tr><tr><td>JUSTIFICATION</td><td></td></tr><tr><td colspan="2">BY</td></tr><tr><td colspan="2">DISTRIBUTION/</td></tr><tr><td colspan="2">AVAILABILITY CODES</td></tr><tr><td>DISTRIBUTION</td><td>AVAILABILITY AND/OR SPECIAL</td></tr><tr><td>A-1</td><td></td></tr></table>		ACCESSIONED BY		NTIS	GRAM <input checked="" type="checkbox"/>	DTIC	TRAC <input type="checkbox"/>	UNANNOUNCED	<input type="checkbox"/>	JUSTIFICATION		BY		DISTRIBUTION/		AVAILABILITY CODES		DISTRIBUTION	AVAILABILITY AND/OR SPECIAL	A-1		DATE ACCESSIONED		
ACCESSIONED BY																								
NTIS	GRAM <input checked="" type="checkbox"/>																							
DTIC	TRAC <input type="checkbox"/>																							
UNANNOUNCED	<input type="checkbox"/>																							
JUSTIFICATION																								
BY																								
DISTRIBUTION/																								
AVAILABILITY CODES																								
DISTRIBUTION	AVAILABILITY AND/OR SPECIAL																							
A-1																								
DISTRIBUTION STAMP		DATE RETURNED																						
DATE RECEIVED IN DTIC		REGISTERED OR CERTIFIED NUMBER																						

H
A
N
D
L
E

W
I
T
H

C
A
R
E

Reproduced From
Best Available Copy

19981223 010

PHOTOGRAPH THIS SHEET AND RETURN TO DTIC-FDAC

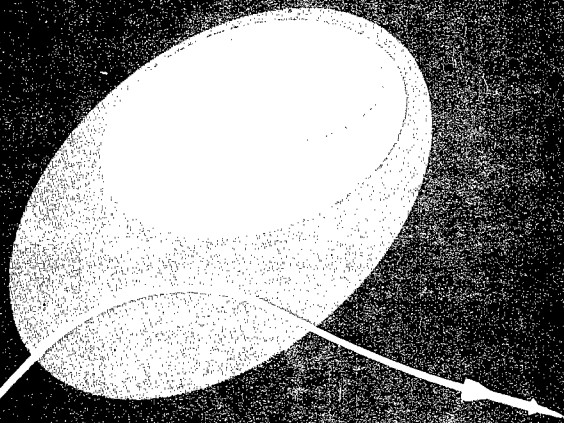

NO DISTRIBUTION
STATEMENT

NAVY
Tech

APPENDIX 9
RMP RESOURCE MANAGEMENT MODULE
FINAL SOFTWARE REPORT
DATA ITEM NO. A005

INTEGRATED ELECTRONIC WARFARE SYSTEM ADVANCED DEVELOPMENT MODEL (ADM)

7800987-10

PREPARED FOR:
NAVAL AIR DEVELOPMENT CENTER
WARMINSTER, PENNSYLVANIA
CONTRACT N62269-75-C-0070



ELECTROMAGNETIC
SYSTEMS DIVISION

1 OCTOBER 1977

UNCLASSIFIED

APPENDIX 9
RESOURCE MANAGEMENT SOFTWARE DESIGN SPECIFICATION
FINAL SOFTWARE REPORT
DATA ITEM A005

INTEGRATED ELECTRONIC WARFARE SYSTEM (IEWS)
ADVANCED DEVELOPMENT MODEL (ADM)

Contract No. N62269-75-C-0070

Prepared for:
Naval Air Development Center
Warminster, Pennsylvania

Prepared by:
RAYTHEON COMPANY
Electromagnetic Systems Division
6380 Hollister Avenue
Goleta, California 93017

1 OCTOBER 1977

TABLE OF CONTENTS

<u>Section</u>	<u>Title</u>	<u>Page</u>
1.0	SCOPE	3
1.1	Identification	3
1.2	Subprogram Tasks	4
2.0	REFERENCE DOCUMENTS	5
2.1	Performance Specification	5
2.2	Program Design Specification	6
2.3	Data Base Design Document	6
2.4	Miscellaneous Documents	6
3.0	REQUIREMENTS	7
3.1	Resource Management (RMDR)	7
3.1.1	Resource Management Update (RMUP)	7
3.1.2	Process Interrupt (RMPRIN)	8
3.1.3	Priority Override (RMPOVR)	9
3.1.4	Priority Return (RMPRTN)	10
3.1.5	Auxiliary Routines	10
3.2	Subprogram Flow Diagrams	15
3.3	Computer Subprogram Environment	41

1.0 SCOPE

The resource management function shall determine whether each emitter constitutes a threat, and if so, a response shall be determined. This function shall assign a lethality to each threat emitter based on the degree of threat to the IEWS airframe. The emitters shall then be ordered by lethality and resources shall be assigned. Where resources are limited, the emitters of higher lethality shall be assigned those resources preferentially. The function shall also initiate, monitor, and terminate the operation of the emitter tracker (ET), techniques generator (TG), and other units. This function shall also control operation of the SS auxiliary bus for ET and TG data. This function shall assign channels and special technique generators on the basis of function and availability, and shall pass necessary parameters to the units mentioned above.

1.1 IDENTIFICATION

The names of the subroutines described in this document and their mnemonics are shown in Table 1.

Subroutine	Mnemonic
Resource Management	RMDR
Resource Management Update	RMUP
Emitter Assessment	RMEMA
Calculate Lethality	RMCALE
Option Assignment	RMOPA
Process Interrupt	RMPRIN
Priority Override	RMPOVR
Priority Return	RMPRTN
Arrange Priorities	RMARPR
Store ODAT	RMSTOD
E. T. Parameters	RMETPA
Find ETF Number	RMFIET
Resource Assessment	RMRAE
Resource Assignment	RMRAI

1.2 SUBPROGRAM TASKS

The functions to be performed by these routines are shown in Table 2.

Function	Description	Routines
Priority Assignment	The priority assignment function shall assign to each ETF number a lethality, and shall maintain a priority file in which all threat ETF numbers are ordered by lethality. The ordinal position of an entry in the Priority File shall be its priority.	RMDR RMUP RMEMA RMCALE RMPOVR RMPRTN RMFIET RMSTOD RMARPR
Technique Option Selection	The technique option selection function shall select a technique number for each threat ETF entry (lethality \neq 0). The Technique Number chosen for each option shall be a function of the emitter only.	RMDR RMOPA
Resource Assessment	The resource assessment function shall maintain resource assignments. At any time, emitters of higher lethality shall have preferential access to limited resources.	RMDR RMRAE
Resource Assignment	The resource management function shall maintain a resource file which shall contain the status of those resources which are limited, such as special generators and response channels. These resources shall be assigned according to function and availability. This function shall also compute parameters to be sent to the emitter tracker as necessary, and shall also maintain the jam status file in which the status of the channels is stored.	RMDR RMPRIN RMETPA RMRAI

2.0 REFERENCE DOCUMENTS

The following documents form a part of this specification to the extent specified herein. In the event of conflict, the requirements of this specification shall govern.

2.1 PERFORMANCE SPECIFICATION

The Performance Specification for this software is Raytheon Document Number 061290529, Computer Program Performance Specification for System Controller Unit. The applicable paragraphs are shown in Table 3.

Function	Applicable CPPS Paragraphs
Priority Assessment	3.3.4.1 3.3.4.1.1* 3.3.4.1.2 3.3.4.1.2.1* 3.3.4.1.2.2 3.3.4.1.3
Technique Option Selection	3.3.4.2 3.3.4.2.1* 3.3.4.2.2* 3.3.4.2.3*
Resource Assessment	3.3.4.3 3.3.4.3.1* 3.3.4.3.2* 3.3.4.3.2.2* 3.3.4.3.2.2.2 3.3.4.3.3*
Resource Assignment	3.3.4.4 3.3.4.4.1* 3.3.4.4.2 3.3.4.4.2.1* 3.3.4.4.2.1.1 3.3.4.4.2.1.2* 3.3.4.4.2.2* 3.3.4.4.2.3* 3.3.4.4.2.4 3.3.4.4.3*

* In Part only

2.2 PROGRAM DESIGN SPECIFICATION

The Design Specification for this software is Raytheon Document Number 53959-GT-0750, System Controller CPDS. All sections are applicable.

2.3 DATA BASE DESIGN DOCUMENT

The Data Base Design Document for this software is Raytheon Document Number 53959-GT-0751, System Controller CDBDD. All sections are applicable.

2.4 MISCELLANEOUS DOCUMENTS

The following miscellaneous documents shall govern the design of this software where applicable:

Emitter Tracker Hardware Specification	53959-JK-1201
Sorter Aux Output ICD	53959-JK-1003
SC-Sorter ICD	53959-JK-1002
SC Daisy Chain Bus	53959-CD-1402
Techniques Generator Hardware Specification	53959-HM-0410

3.0 REQUIREMENTS

3.1 RESOURCE MANAGEMENT (RMDR)

The flow chart for subroutine RMDR is shown in Figure 1. This routine shall be called by the executive whenever one of the following occurs:

- ETF Update
- ET Interrupt
- Priority Override
- Priority Return

A message shall accompany the call indicating which of the above occurrences caused the call. Input parameters shall also accompany each message. The message shall cause one of subroutines RMUP, RMPRIN, RMPOVR, or RMPRTN, respectively, to be called. Control shall then be returned to the executive. RMUP shall update certain parameters of the designated ETF entry, and rearrange resources as needed. PRIN shall reprogram the interrupting ET channel. EMPOVR and RMPRTN shall update priorities according to an operator request and shall reassign resources accordingly.

3.1.1 Resource Management Update (RMUP)

The flow chart for subroutine RMUP is shown in Figure 2. The only input parameter shall be EFN (Emitter File Number). Subroutine EMAS shall be called first. Then, if EETESO (Technique Source) for the designated emitter is zero and if the lethality is non-zero, subroutine OPAS shall be called. If a priority or option change has occurred (DPTY = 1 or DOPT = 1, respectively), then subroutine RMRAE shall be called. Control shall then be returned to the calling routine.

3.1.1.1 Emitter Assessment (RMEMA)

The flow chart for subroutine RMEMA is shown in Figure 3. The only input parameter shall be EFN (Emitter File Number). Subroutine RMCALE shall be called first. If the absolute value of the change in lethality is greater

than LTHR (Lethality Threshold), then subroutine RMARPR shall be called. If RMARPR is called and if the lethality of the designated emitter is equal to zero, then subroutine RMRAI shall be called to delete any response (TECH = 0) to the emitter. Four subroutines shall then be called consecutively. Their pointers are given by E2PTRA, -B, -C, and -D, respectively. These subroutines shall be used to control devices external to IEWS, and they are currently undefined. Control shall then be returned to the calling routine.

3.1.1.1.1 Calculate Lethality (RMCALE) - The flow chart for subroutine RMCALE is shown in Figure 4. The only input parameter shall be EFN (Emitter File Number). NLET (New Lethality) shall be replaced by E2FA (Function A) for the designated emitter, and control shall be returned to the calling routine.

3.1.1.2 Option Assignment (RMOPA)

The flow chart for subroutine RMOPA is shown in Figure 5. The only input parameter shall be EFN (Emitter File Number). TECH (Technique) shall be set equal to the newly specified technique (E2TEC1 from the EF) for the designated emitter. If TECH does not equal the old specified technique (EFPTEC, from the ETF), then DOPT (Delta Option) shall be set and EFPTEC shall be replaced by TECH. Otherwise, DOPT shall be reset. Control shall then be returned to the calling routine.

3.1.2 Process Interrupt (RMPRIN)

The flow chart for subroutine RMPRIN is shown in Figure 6. The only input parameter shall be TDIN (Track Drop Interrupt). If TDIN is equal to zero, then control shall immediately be returned to the calling routine. If not, each bit shall be tested from left to right until one is found which is set. CNUM (Channel Number) will be set equal to the position of that bit (l. s. b. = 0). Subroutine RMETPA shall then be called. The process shall then be repeated until all bits have been checked, and control shall be returned to the calling routine.

3.1.3 Priority Override (RMPOVR)

The flow chart for subroutine RMPOVR is shown in Figure 7. Input parameters shall be EFN (Emitter File Number) and NPTY (New Priority). First, subroutine RMFIET (Find ETF Number) shall be called, which shall return as PIDX (Priority Index), the current priority of the designated emitter. PFPRSO (Priority Source) shall be set for PIDX, and if NPTY is too large (\geq DCTHTO, Threat Total), then NPTY shall be replaced by DCTHTO-1. If NPTY = PIDX, control shall be returned immediately to the calling routine. Otherwise, ODAT (Old Data) shall be replaced by the entry at PIDX, and a search shall be made for the first entry below NPTY in which PFPRSO (Priority Source) = 0 (SC Control of Priority). The position of that entry shall be designated XIDX. If NPTY is less than PIDX, then all entries between PIDX and NPTY must be moved down one (or below any adjacent "clumps" of entries with PFPRSO = 1 [not SC-controlled]), and the following processing shall occur. DIDX (Difference Index) shall be set equal to 1. If PIDX is greater than XIDX, then DIDX is replaced by one plus the number of consecutive entries above PIDX (\leq PIDX) with PRPRSO = 1. If PIDX is not equal to NPTY, then the first entry above PIDX with PRPRSO = 0 (PIDX-DIDX) is moved down to PIDX. PIDX is then replaced by (PIDX-DIDX), and the whole process is repeated until all entries below XIDX have been moved down one (or immediately below an adjacent clump of entries with PFPRSO = 1). If, however, there is an entry with PFPRSO = 1 at NPTY, that entry and all adjacent entries below with PFPRSO = 1 shall be moved down also. Therefore, when $PIDX \neq XIDX$, then DIDX shall remain equal to 1. On the other hand, when $NPTY < PIDX$, then all entries between PIDX and NPTY must be moved up in a similar manner. In addition, when, finally, PIDX equals XIDX, then all of the entries between XIDX and NPTY (PFPRSO = 1) must be moved down one. This latter is accomplished using the coding for the case, $NPTY < PIDX$. In either case, whenever PIDX finally equals NPTY, the moving of files is finished, and subroutines RMSTOD (Store ODAT) and RMAE (Resource Assessment) shall be called, and control shall be returned to

the calling routine. Whenever the first entry is being considered for downward movement ($PIDX - DIDX = 1$) or the last entry is being considered for upward movement ($PIDX + DIDX = THTO$), the processing shall proceed as for $PIDX = NPTY$.

3.1.4 Priority Return (RMPRTN)

The flow chart of subroutine RMPRTN is shown in Figure 8. The input parameters shall be RALL(Return All) and EFN (Emitter File Number). If only one emitter is to be returned to SC-control ($RALL = 0$), the subroutine DCFIET shall be called to find the Priority (PIDX - Priority Index) of that emitter. PFPRSO (Priority Source) shall then be reset and RMARPR (Arrange Priorities) shall be called. If, on the other hand, $RALL = 1$, then for each PF entry with $PFPRSO = 1$, PFPRSO shall be reset and subroutine RMARPR shall be called. When all files have been processed, or when the single designated file has been processed (for $RALL = 0$), then if DPTY (Delta Priority) is set, subroutine RMRAE shall be called. Control shall then be returned to the calling routine.

3.1.5 Auxiliary Routines

There shall be several subroutines which are called by more than one of the above routines.

3.1.5.1 Arrange Priorities (RMARPR)

The flow chart for subroutine RMARPR is shown in Figure 9. The input parameters shall be PIDX (Priority Index), NLET(New Lethality), and EFN (Emitter File Number). The similarity between this subroutine and subroutine RMPOVR should be noted. DPTY (Delta Priority) shall be reset. At this point, processing may proceed in three directions, depending on whether an emitter is being added, moved or deleted. If an emitter is being added ($EFLETH [EFN] = 0$), then PIDX shall be replaced by the PF entry at PIDX,

and file movement processing shall then proceed very much like subroutine RMPOVR. If an emitter is being moved ($EFLETH > 0$ and $NLET > 0$) then PRIO (Priority) shall be replaced by PIDX, ODAT shall be replaced by the PF entry at PIDX, and file movement processing shall proceed. However, if PRSO for the designated entry is set (non-SC control), the EFLETH (Lethality) shall be replaced by NLET and control shall be returned to the calling routine. Finally, if the emitter is being deleted ($LETH > 0$ and $NLET = 0$), then THTO shall be decremented by 1, DPTY shall be set, and the files below the deleted file shall be moved up one (or just above any adjacent clumps with entries with $PRPRSO = 1$). This processing is very similar to the file movement processing, which will now be described in detail. First, OPTY (Old Priority) shall be replaced by PIDX. If the new Lethality is greater than the old ($NLET > LETH$ [EFN]), then all entries with EFLETH between EFLETH (EFN) and NLET must be moved down one (or below any adjacent "clumps" of entries with $PRPRSO = 1$), and the following processing shall occur. DIDX (Difference Index) shall be set equal to one plus the number of consecutive entries above PIDX ($< PIDX$) with $PFPRSO = 1$. The first entry above PIDX with $PFPRSO = 0$ ($PIDX - DIDX$) is then moved down to PIDX. PIDX is then replaced by ($PIDX - DIDX$), and the process is repeated until all entries with $EFLETH < NLET$ have been moved down one (or immediately below an adjacent clump of entries with $PRSO = 1$). On the other hand, when $NLET < (EFN)$, then all entries with EFLETH between EFLETH (EFN) and NLET must be moved up in a similar manner. In either case, when the moving of files is finished, subroutine RMSTOD (Store ODAT) shall be called, EFLETH (EFN) shall be replaced by NLET, and control shall be returned to the calling routine.

3.1.5.2 Store ODAT (RMSTOD)

The flow chart for subroutine RMSTOD is shown in Figure 10. Input parameters shall be PIDX (Priority Index), ODAT (Old Data), and OPTY (Old Priority). If DCTHTO (Threat Total) is equal to 128, then it shall be decremented by one. The entry at PIDX shall be replaced by ODAT, and if $OPTY = PIDX$, then DPTY (Delta Priority) shall be set. Control shall then be returned to the calling routine.

3.1.5.3 Emitter Tracker Parameters (RMETPA)

The flow chart for subroutine RMETPA is shown in Figure 11. The only input parameter shall be CNUM (Channel Number). If a Primary Channel is indicated ($CNUM \leq 7$), then data shall be output to ET channel CNUM and processing shall proceed as follows: TPRI (Tracker PRI) shall be replaced by ten times EFAVPRI (Average PRI) for the designated channel and output to the ET. PP (poll Period) shall be replaced by E2POLL (Poll Period), as specified in the appropriate entry in the EL, and output to the ET. If EFQPRI (PRI Quality) for the designated emitter is greater than 2, then GWP (Gate Width Primary) shall be set equal to one and sent to the ET. Otherwise, GWP shall be set equal to zero. Control shall then be returned to the calling routine. On the other hand, if an alternate channel is indicated ($CNUM > 7$), then data shall be output to ET channel ($CNUM + 8$), and processing shall proceed as follows: CYPE (Cycle Period) shall be replaced by EFAVPRI for the designated emitter. If EFSTAG (Stagger) for that emitter is not equal to one, then CYPE shall be doubled. GWA (Gate Width - Alternate) shall be set equal to $2^{(EFQPRI-2)}$, and PTGW (Pretrigger Gate Width) shall be set equal to 25. Then JG (Jam Gate) shall be set equal to TLPT (Pretrigger) for the technique corresponding to the designated emitter, and JG shall be sent to the ET. PTGW shall be doubled, at this point, if $JG = 1$. Then DELAY shall be set equal to $CYPE - 64 - PTGW$, and sent to the ET. If GWA is greater than PTGW, then GWA shall be replaced by PTGW. GWA shall then be sent to the ET. PP shall not be set equal to E2POLL, for the designated emitter, and sent to the ET for the designated emitter and sent to the ET. HC (Hit Count) shall be set equal to E2HIT, for the designated emitter and sent to the ET. Control shall then be returned to the calling routine.

3.1.5.4 Find ETF Number (RMFIET)

The flow chart for subroutine RMFIET is shown in Figure 12. The only input parameter shall be EFN (Emitter File Number). This subroutine shall search the PF from bottom to top (DCTHT0-1 to 0) until it finds the designated emitter. When it does, the Priority of that emitter is returned as PIDX (Priority Index), and control is returned to the calling routine.



RAYTHEON COMPANY
LEXINGTON, MASS. 02173

CODE IDENT NO.
49956

SPEC NO.
SHEET 13 OF 45 REV

3.1.5.5 Resource Assessment (RMRAE)

The flow chart for subroutine RMRAE is shown in Figure 13. There shall be no input parameters. First, the PF shall be searched for the first (smallest priority) non-active entry (PFAR = 0). If an A-generator is required (TLSPGNA = 1) and all are busy (RFGENA = 7), then the PF shall be searched from the bottom up for an active entry (PFAR = 1) of lower priority (RIDX > PIDX) which is using an A-generator. If one is found, then that response shall be deleted by replacing PRIO (Priority) by RIDX, replacing TECH (Technique) by 0 (Delete), calling subrouting RMRAI, and proceeding to Tracker assignment. If the search for a busy A-generator fails, PF entry PIDX shall remain non-active. If, on the other hand, an A-generator is required and all are not busy (TLSPGNA = 1 and GENA ≠ 7), then control shall proceed immediately to Tracker Assignment. If an A-generator is not required, then the same tests that were carried out for an A-generator shall be carried out for a D-generator. However, all D-generators busy shall be indicated by RFGEND = 0'177'. Tracker assignment shall proceed as follows: If the Tracker type required is Primary (TLTT = 0), then the JSF shall be searched in channels 0-7 (0 ≤ JIDX ≤ 7) for a non-active entry (JSOPNO=0X). If one is found, then PRIO shall be replaced by JIDX (JSF Index) TECH shall be replaced by PTEK for the designated emitter, and subroutine RMRAI shall be called. Processing shall then terminate on PF entry PIDX. If no non-active channel is found, then the PF shall be searched from the bottom (RIDX=DCTHTO-1) for an entry of lower priority (RIDX > PIDX) using the necessary Tracker type (PFCHNO(RIDX) > 8). If one is not found, PF entry PIDX shall remain inactive. If, on the other hand, an alternate tracker is required (TLTT = 1), the same procedure shall be implemented for JSF entries 8-15. If Tracker type is optional (TLTT=2), then a non-active Primary channel shall be sought, and, if necessary, a non-active alternate channel. If neither is available then a lower priority of either Tracker type shall be sought. When processing for PF entry has terminated, the entire procedure above shall be repeated for every non-active PF entry, from top-to-bottom (0 to DCTHTO-1). Control shall then be returned to the calling routine.

RAYTHEON	RAYTHEON COMPANY LEXINGTON, MASS. 02173	CODE IDENT NO. 49956	SPEC NO.	
			SHEET 14 OF 45	REV

3.1.5.5.1 Resource Assignment (RMRAI). The flow chart for subroutine RMRAI is shown in Figure 14. The input parameters shall be PRIO (priority) and TECH (Technique). ETFN (ETF Number) and CNUM (Channel Number) shall be replaced by PFETFA (ETF Address) and PFCHNO (Channel Number), respectively, for the designated emitter. If the emitter is to be deleted (TECH=0), the processing shall proceed as follows. Channel CNUM shall be disabled in the TG and ET, and Aux Bus output from track file ETFN shall be disabled in the SS. The last shall be accomplished by sending an SS Message to the Exec. If an A-generator is being used by channel CNUM (JSGENA = 1), then JSGENA shall be replaced by zero, and RFGENA shall be decremented by one. Similarly, if a D-generator is being used by channel CNUM(JSGEND=0), then JSGEND shall be replaced by zero, and RFGEND shall be decremented by one. JSOPNO, JSGEND, EFENG (Engaged), and PFAR (Active Response) for the designated emitter shall all be replaced by zero, and control shall be returned to the calling routine. If, on the other hand, TECH = 0, then processing shall proceed as follows: JSJSEF (JSF Emitter File Number) shall be replaced by ETFN for channel CNUM. If a D-generator is required (TLSPGND-1), then JSGEND shall be replaced by zero (for the appropriate channel), and RFGEND shall be incremented by one. If no D-generator is required, then JSGEND shall be replaced by 1. Similarly, if an A-generator is required (TLSPGNA=1) then JSGENA shall be replaced by zero, and RFGENA shall be incremented by 1. Otherwise, TSGENA shall be replaced by 1. Then CHNS (Channel Number SS) for track file ETFN shall be replaced by CNUM (or by CNUM + 8 if CNUM > 7). CHNS shall then be output to the SS by way of an SS Message to the Exec. JSOPNO shall then be replaced by 2, PFAR (Active Response) shall be set, and EFENG shall be set, all, of course, for the designated emitter. TENO (Technique Number) shall be replaced by EFPTEC (Primary Technique) and sent to the TG (to channel CNUM + 8 if CNUM > 7). TBNG (TB Bearing) shall then be set equal to EFAZ (for the designated emitter) HDG (Heading). TACN (TG Angle Cell Number) shall be replaced by Angle Cell Number found in a table (ATBL) by EFFREQ and TBNG TACN shall then be sent to the TG. TFRQ (TG Frequency) shall be replaced by EFFREQ, for the designated emitter, and sent to the TG. Subroutine RMETPA shall then be called, and control shall be returned to the calling routine.



RAYTHEON COMPANY
LEXINGTON, MASS. 02173

CODE IDENT NO.
49956

SPEC NO.
53959-GT-0752
SHEET
15 OF 45 REV

3.2 SUBPROGRAM FLOW DIAGRAMS

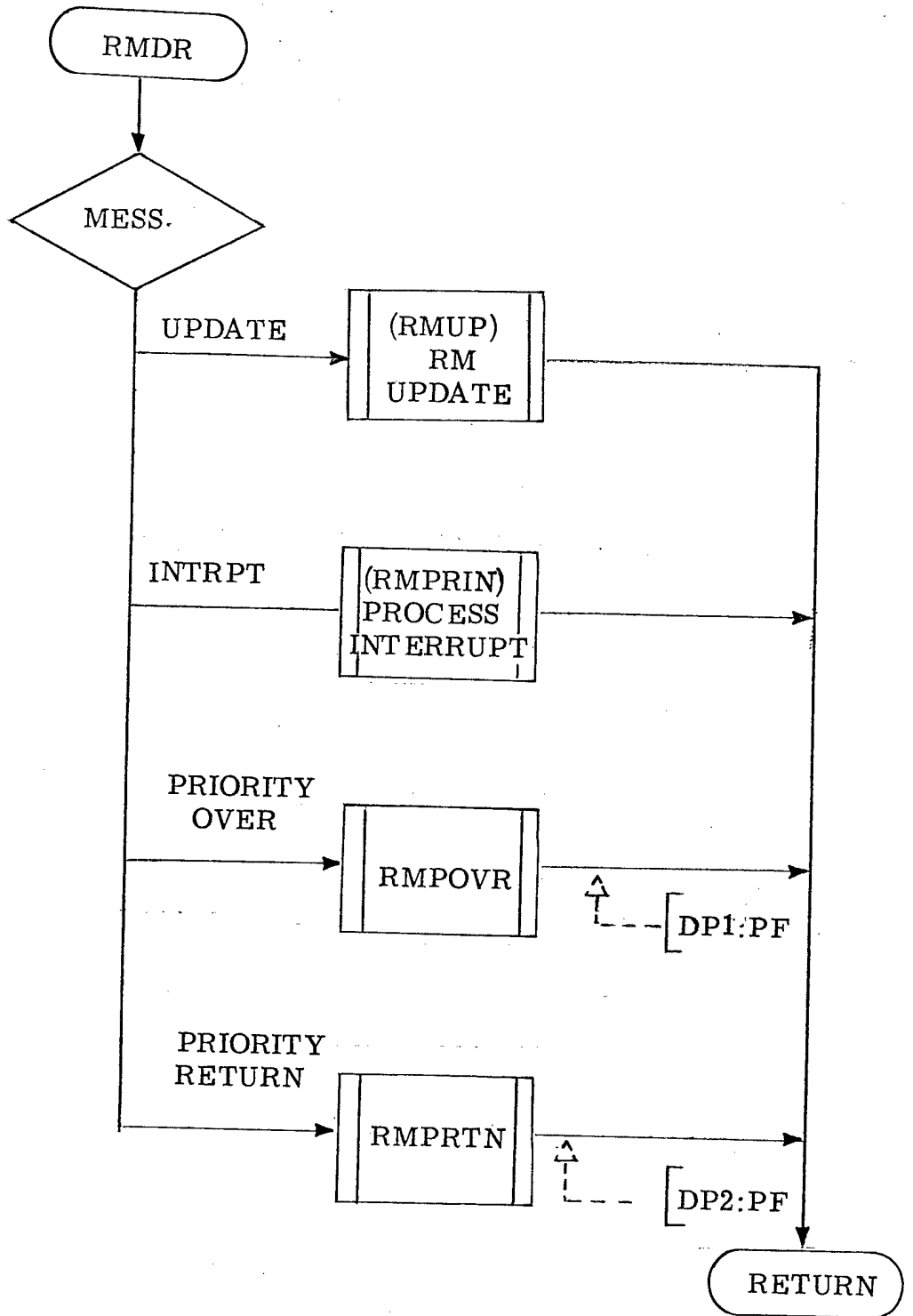

Figure 1. Resource Management (RMDR)

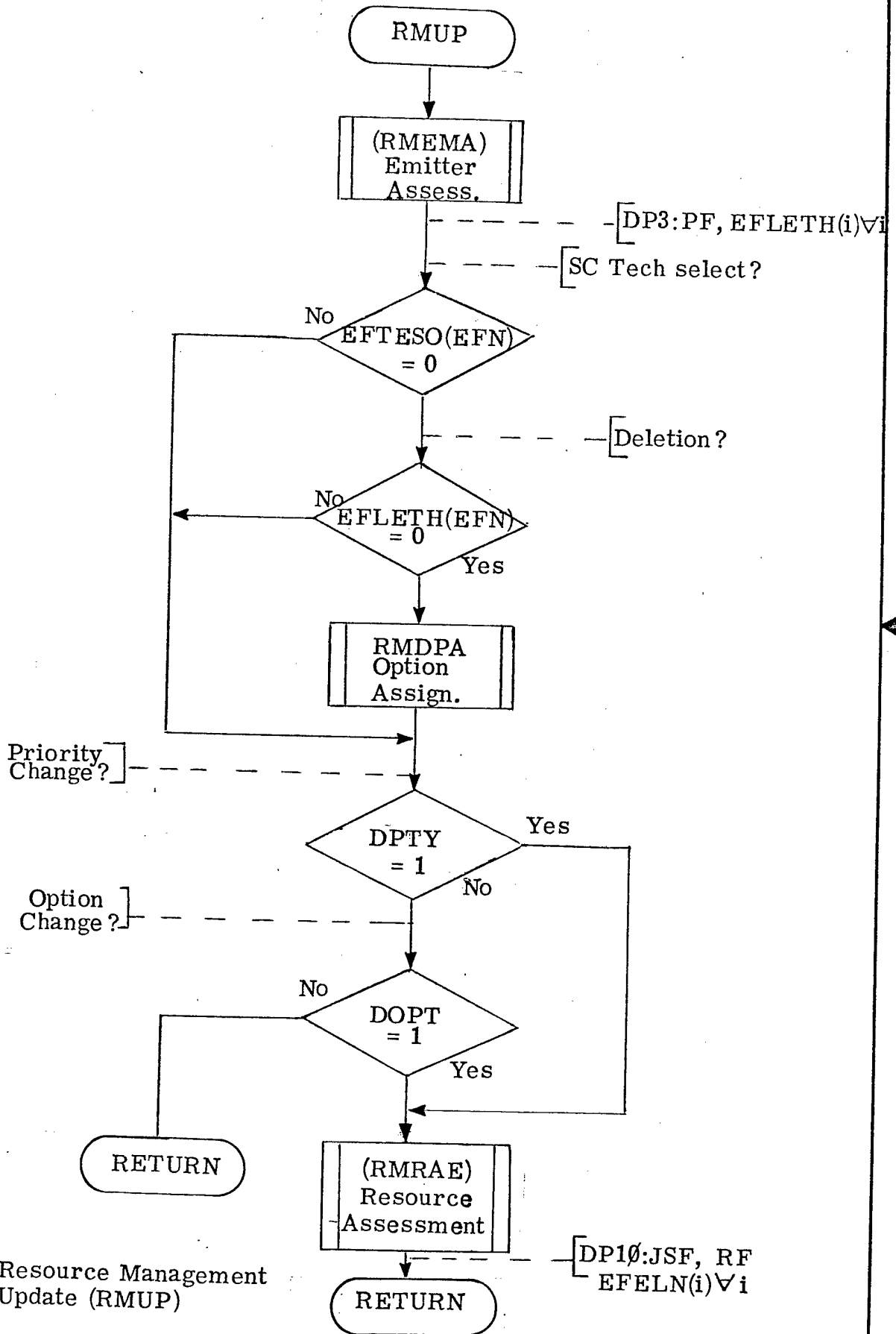

Figure 2. Resource Management Update (RMUP)

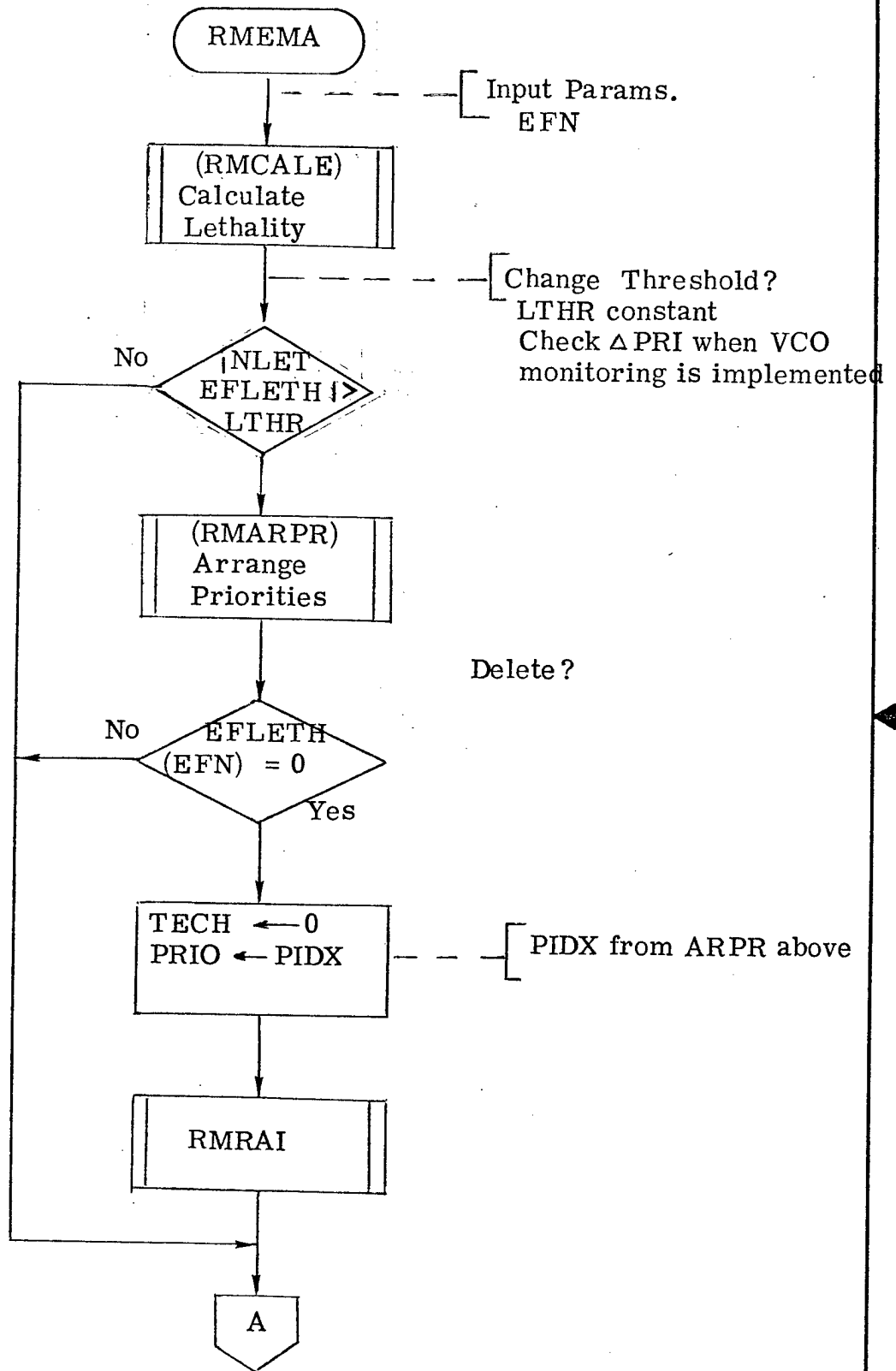

Figure 3. Emitter Assessment (RMEMA)

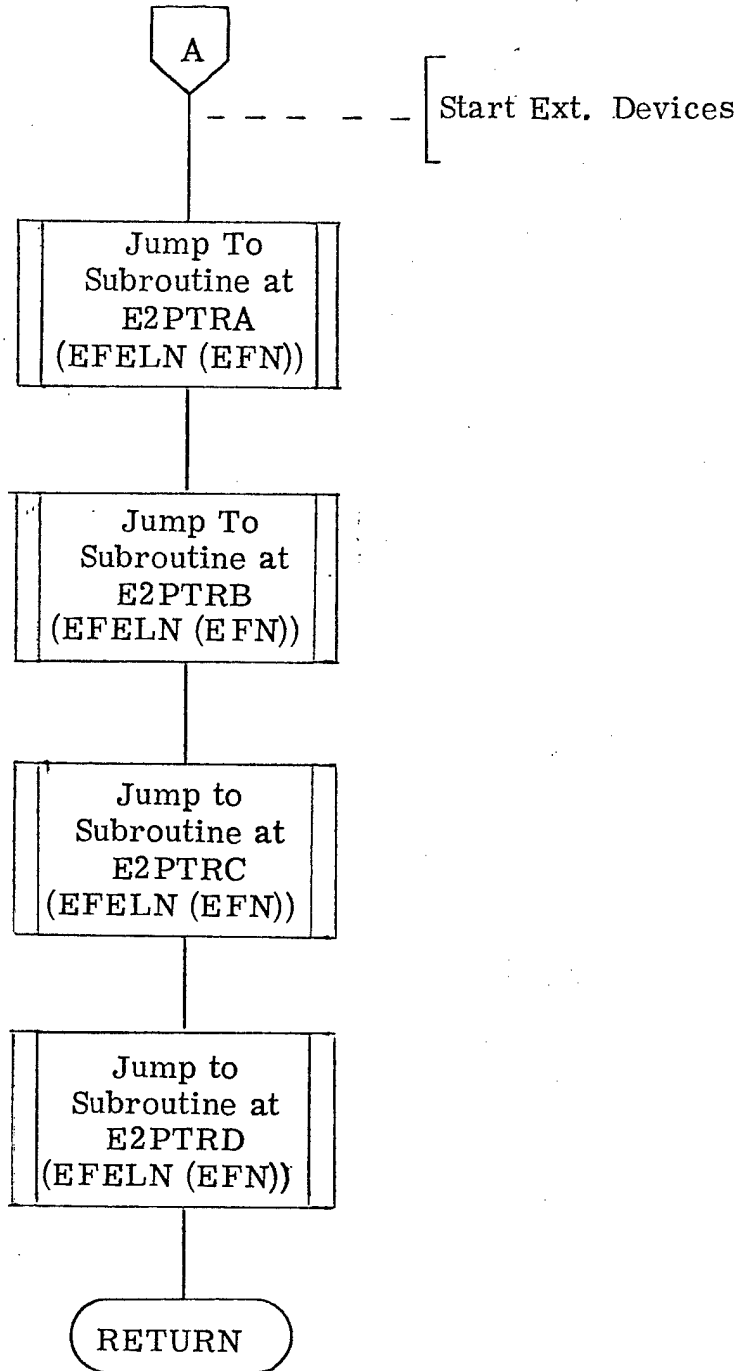

Figure 3. -continued-

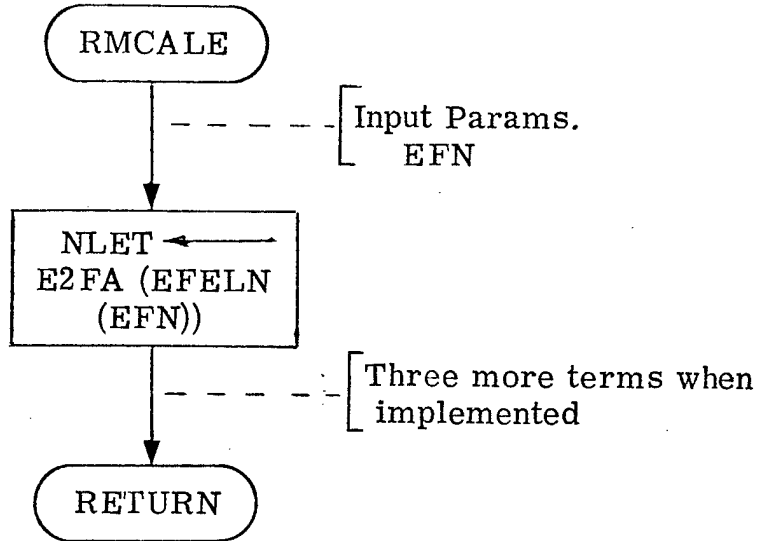

Figure 4. Calculate Lethality (RMCALE)

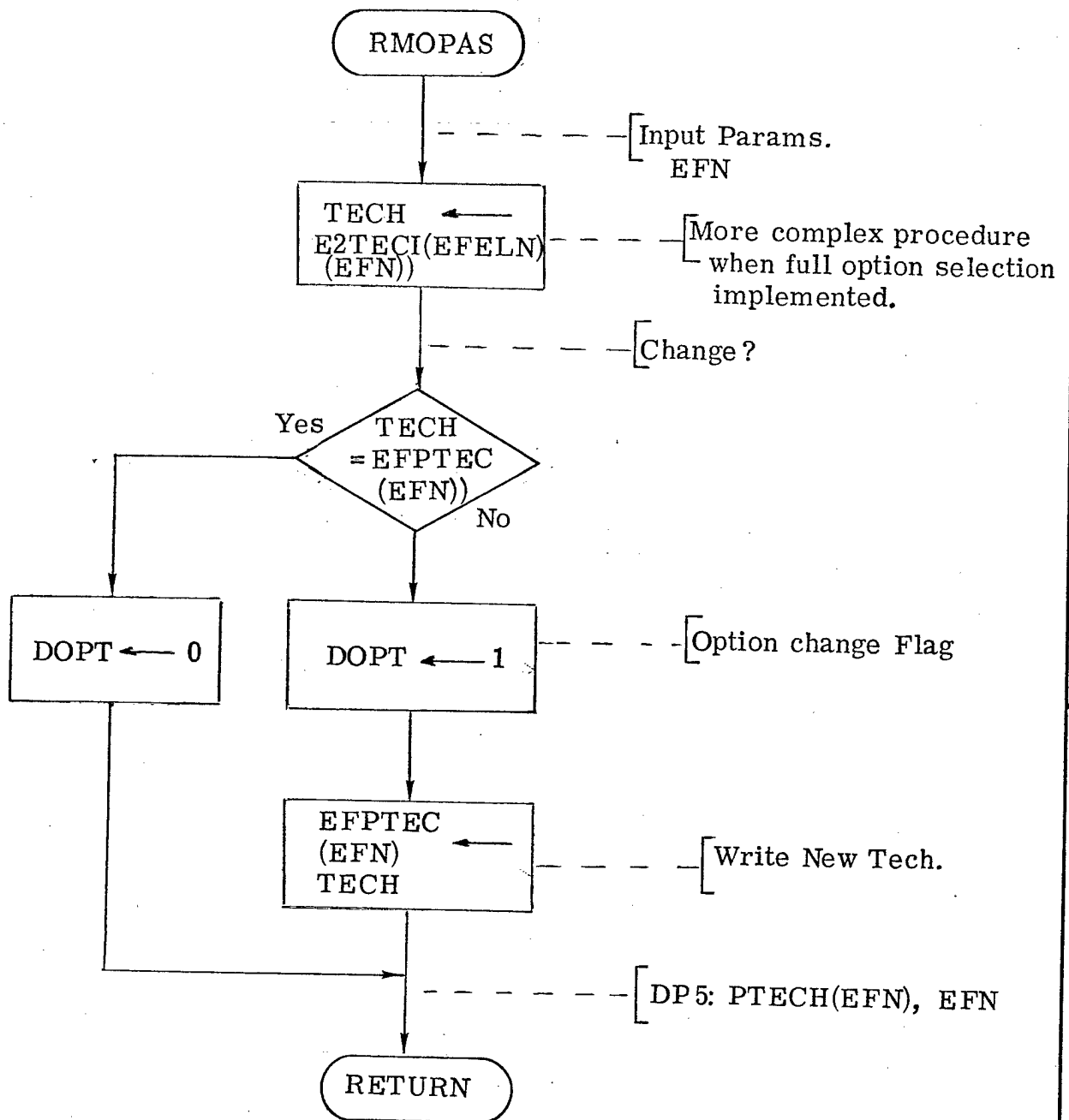

Figure 5. Option Assignment (RMOPA)

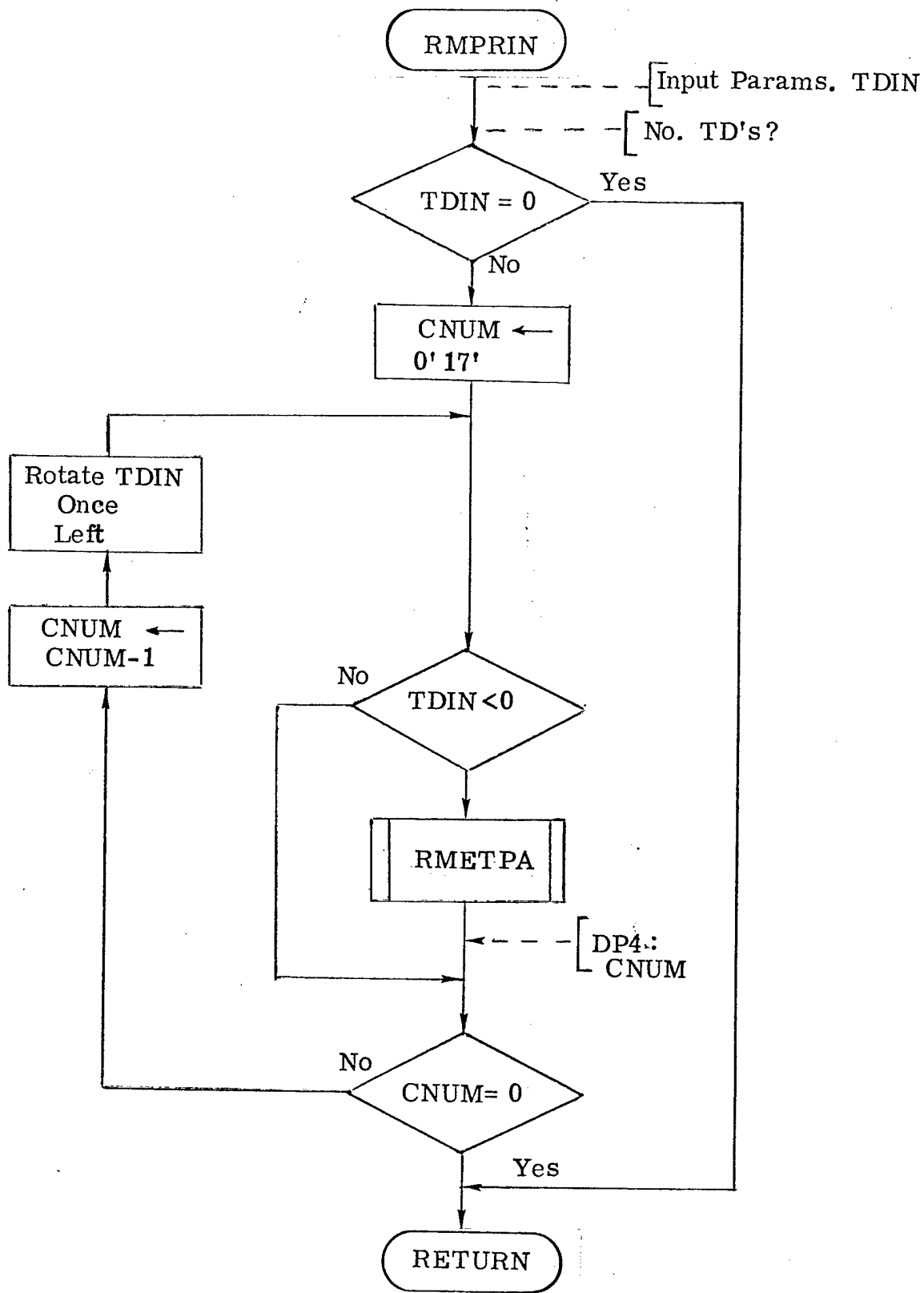

Figure 6. Process Interrupt (RMPRIN)

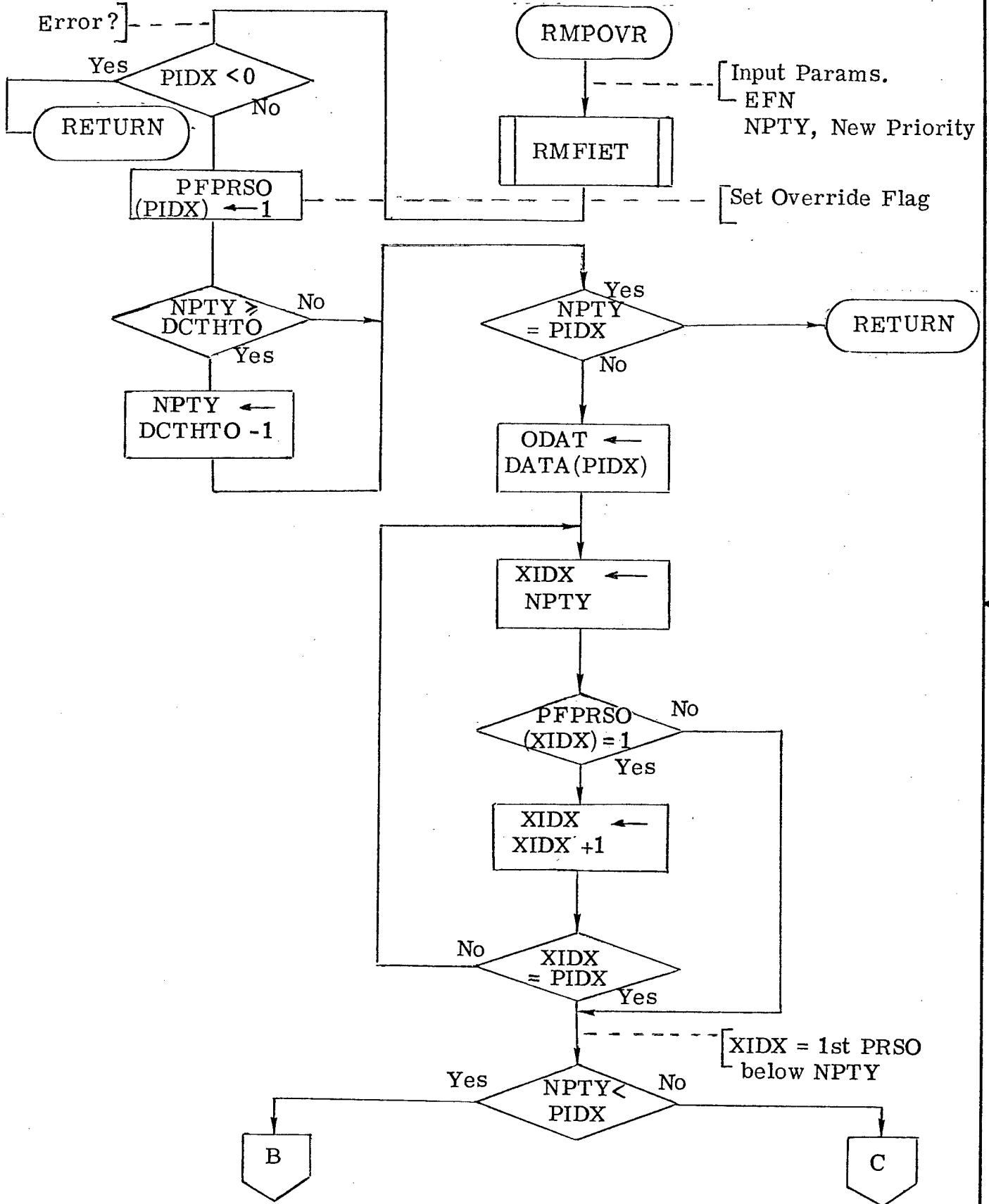

Figure 7. Priority Override (RMPOVR)

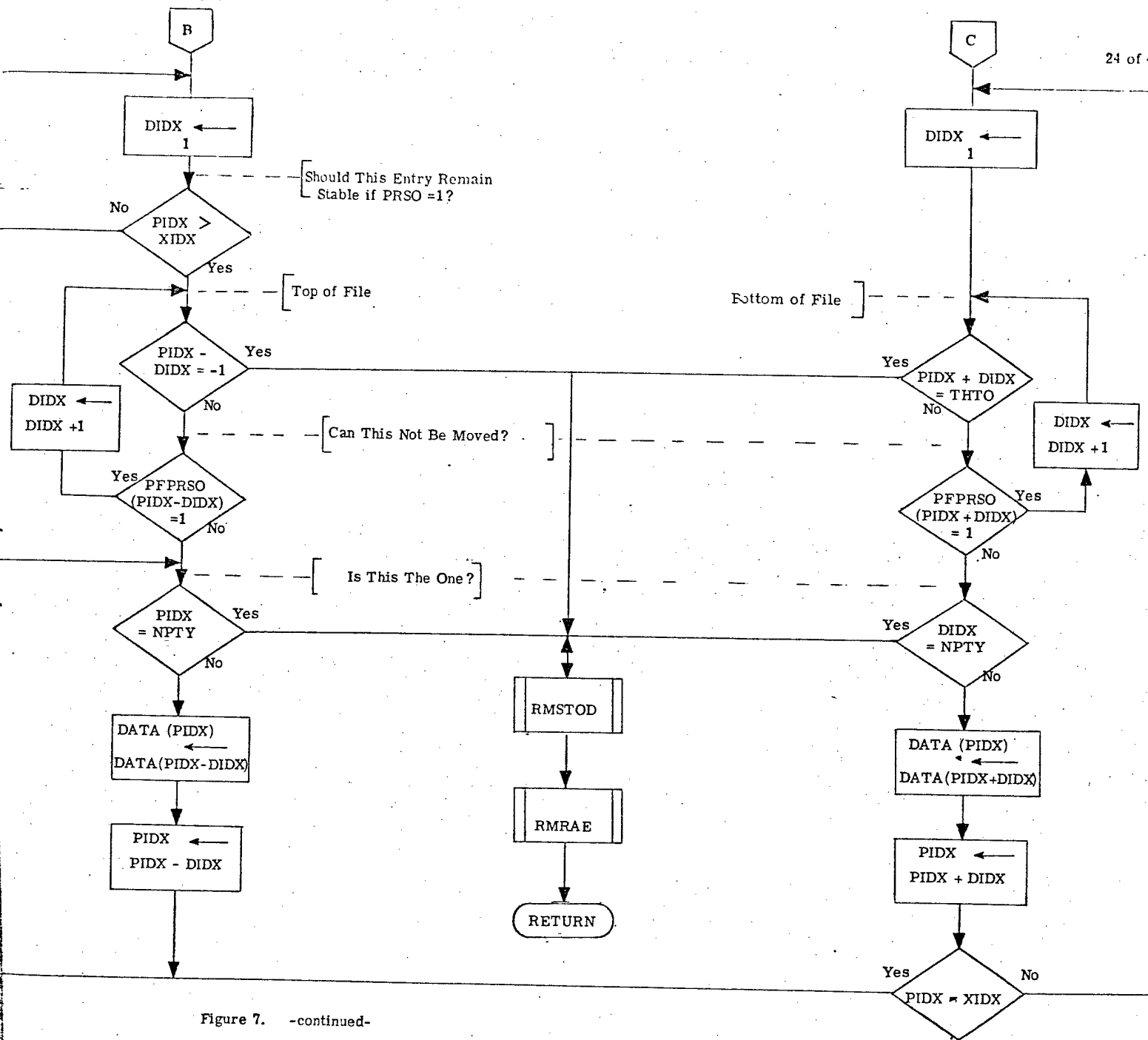

Figure 7. -continued-

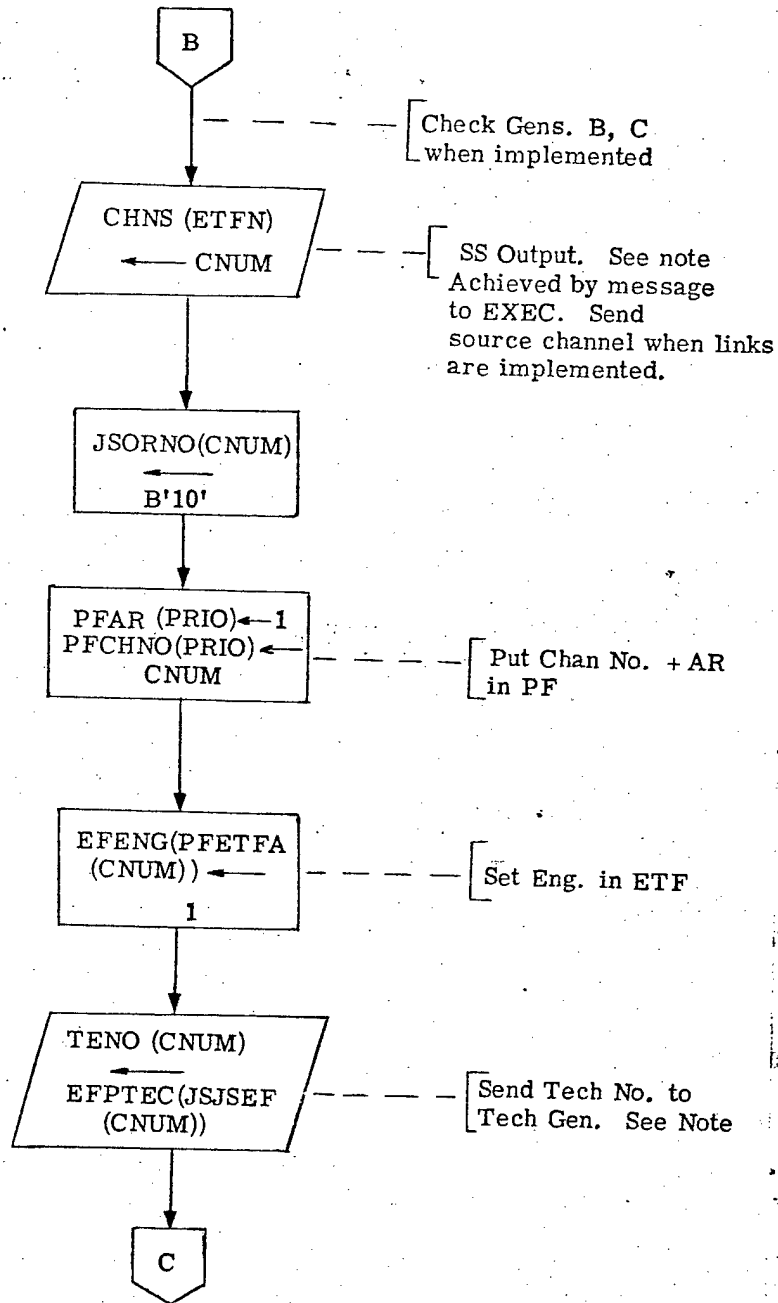

Figure 7. -continued-

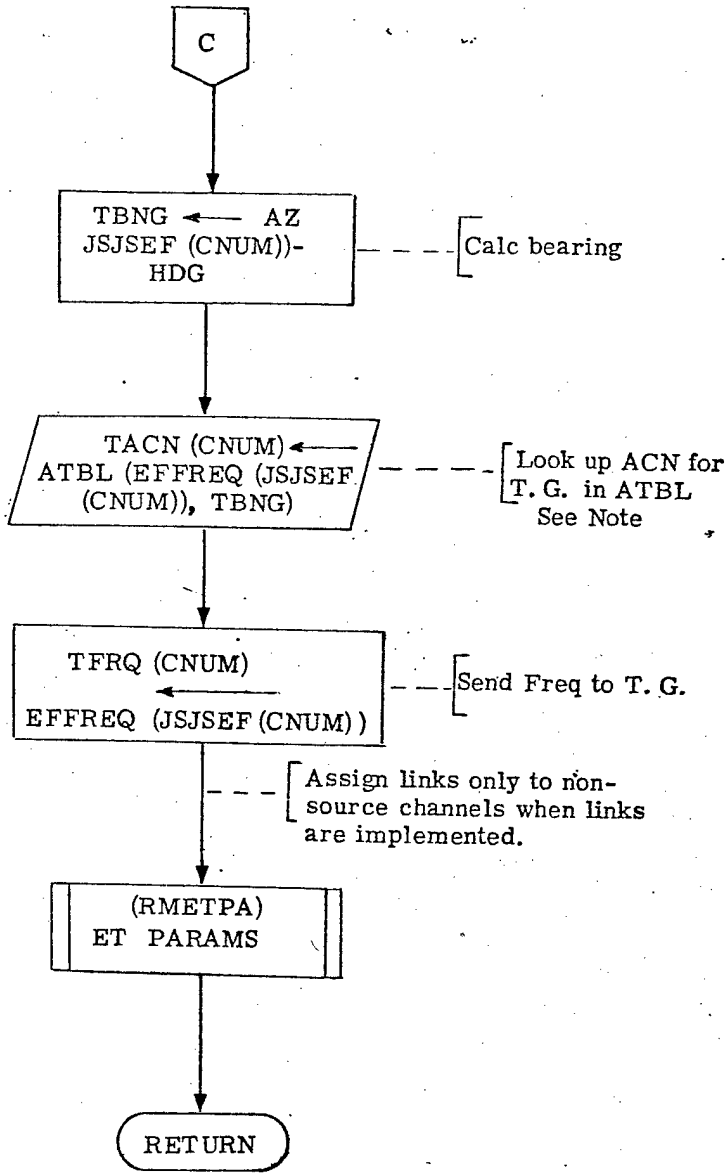

Figure 7. -continued-

Note: All Alt. outputs to CNUM + 0'10'

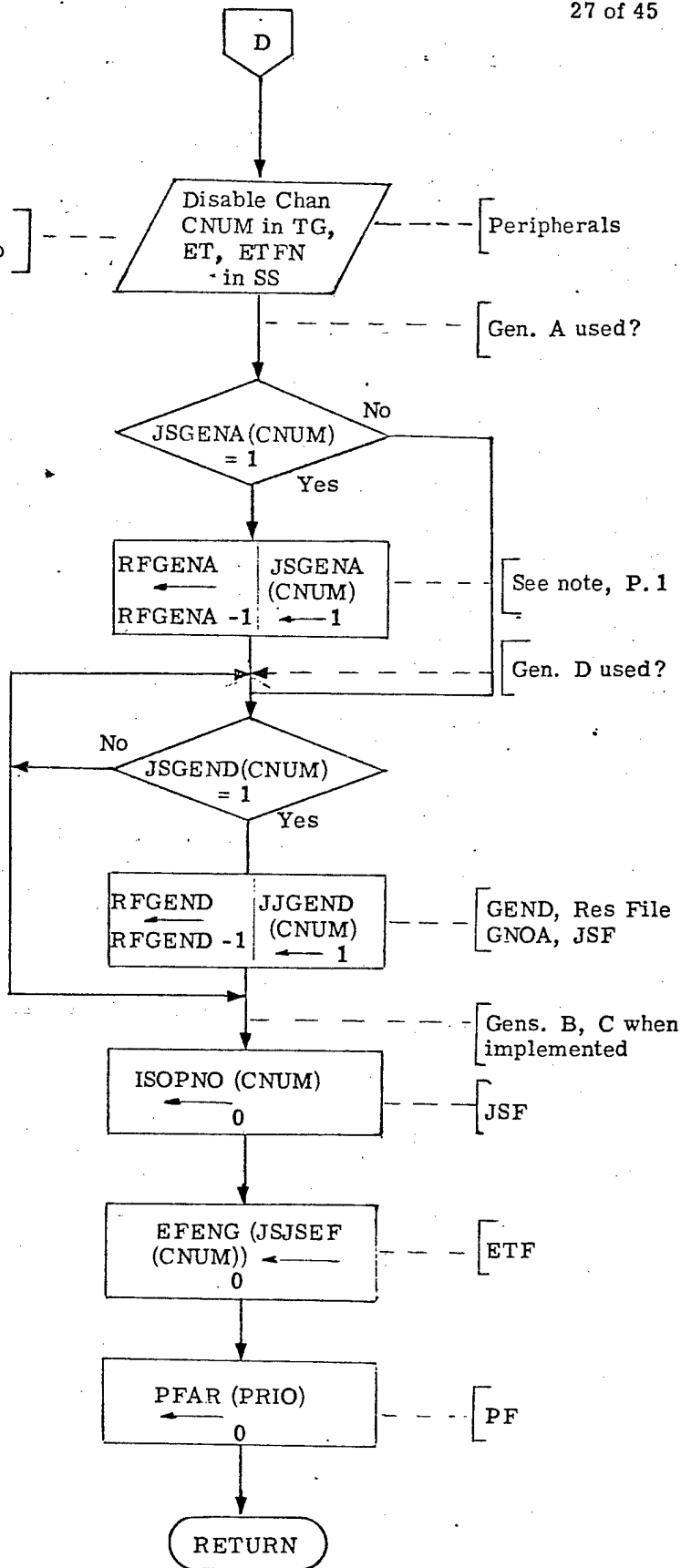

Figure 7. -continued-

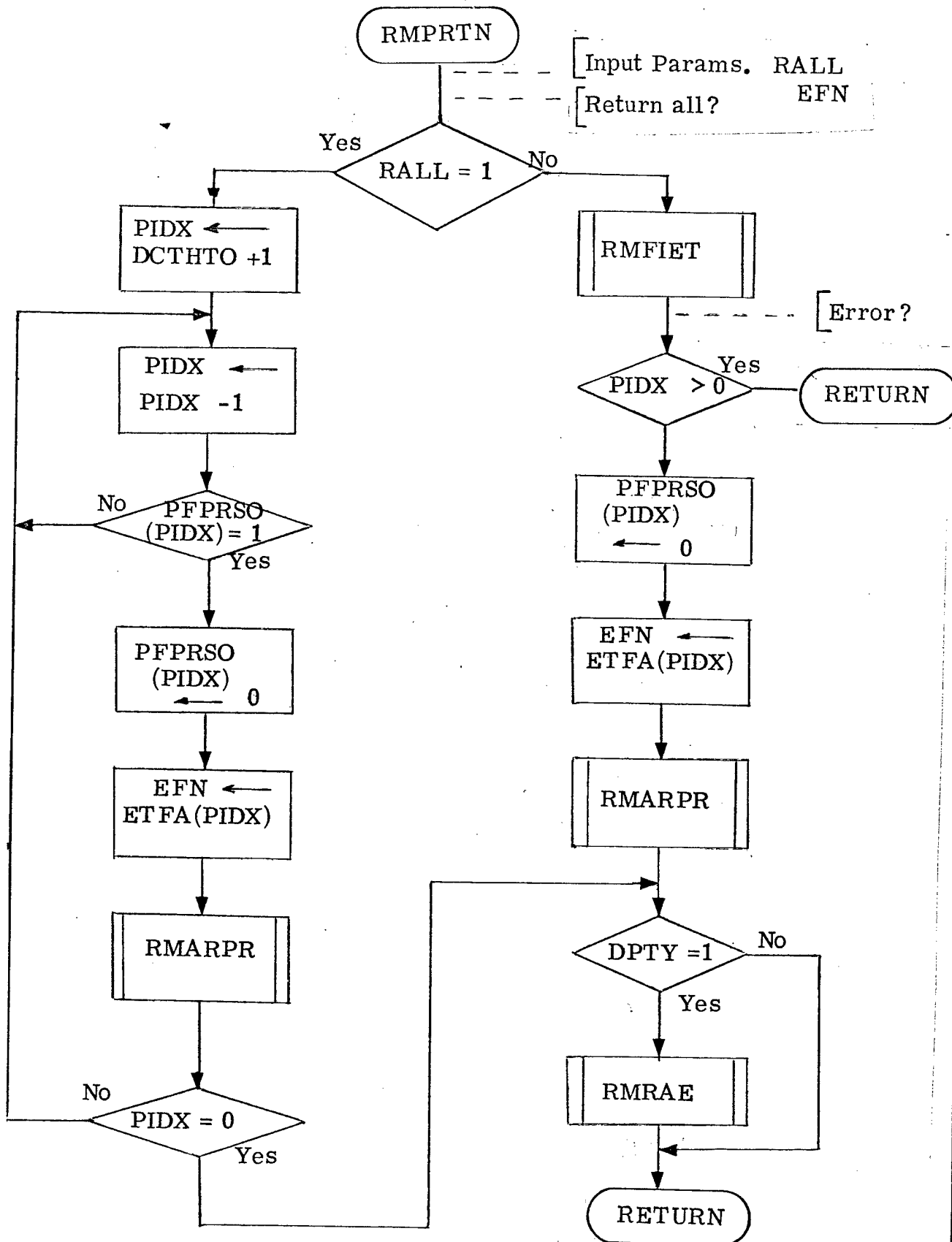

Figure 8. Priority Return (RMPRTN)

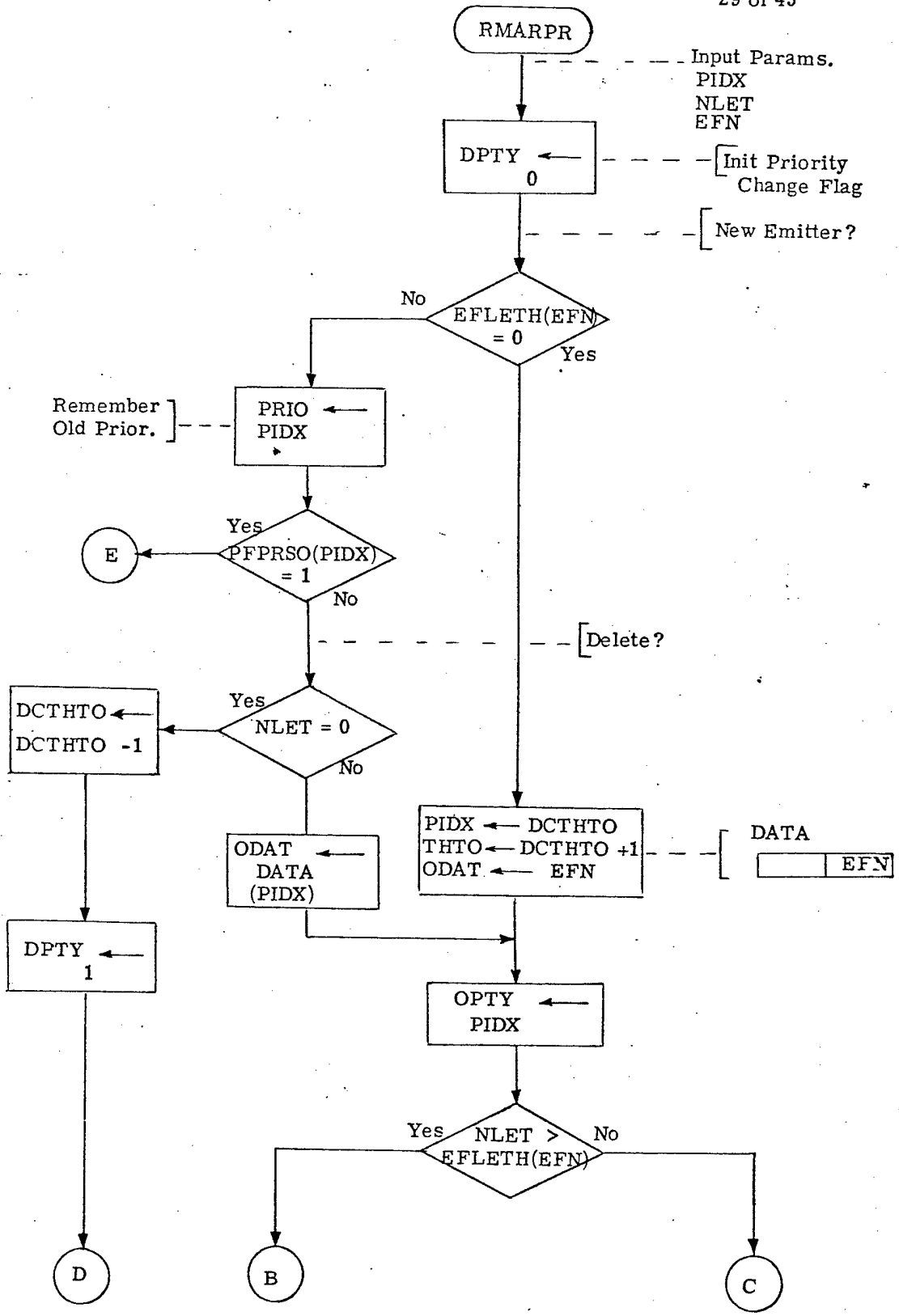

Figure 9. Arrange Priorities (RMARPR)

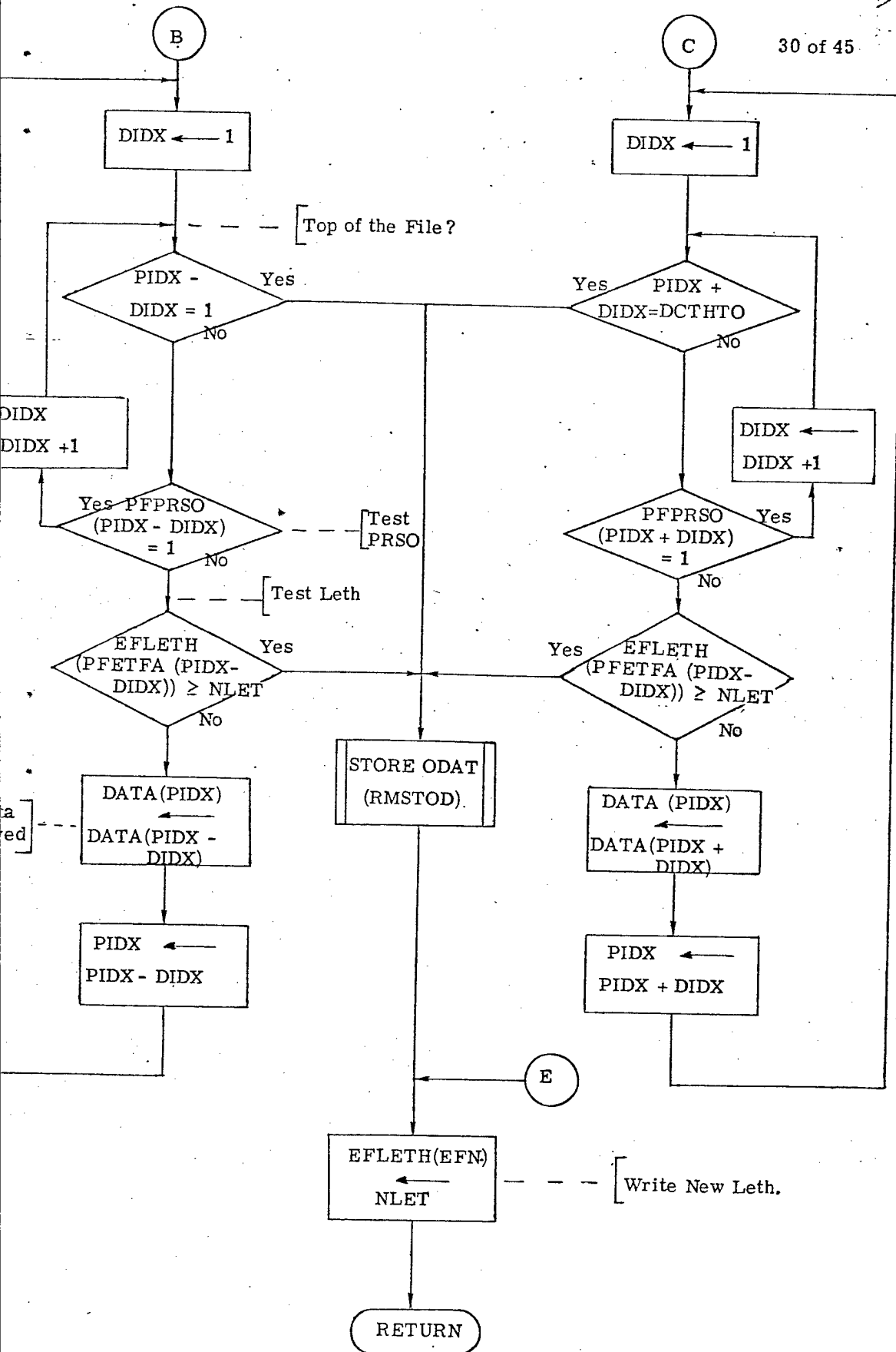

Figure 9. -continued-

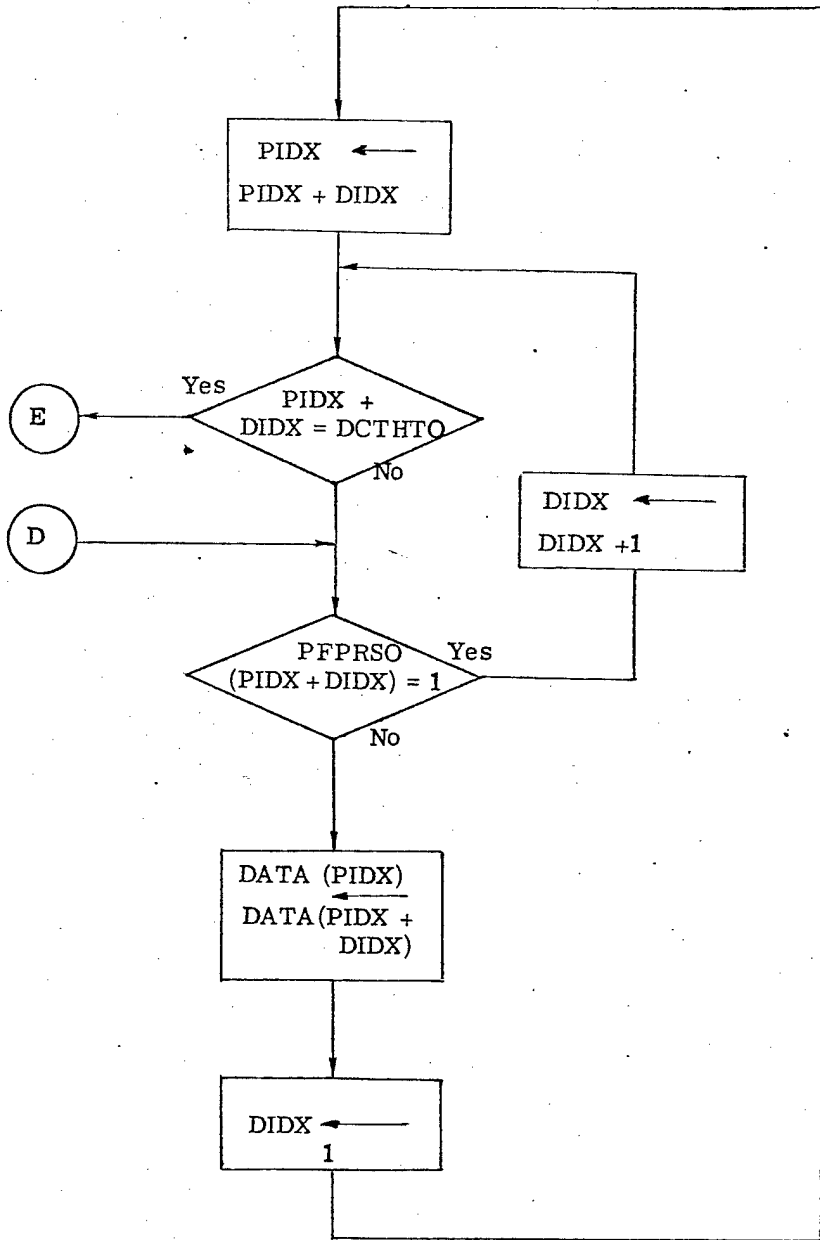

Figure 9. -continued-

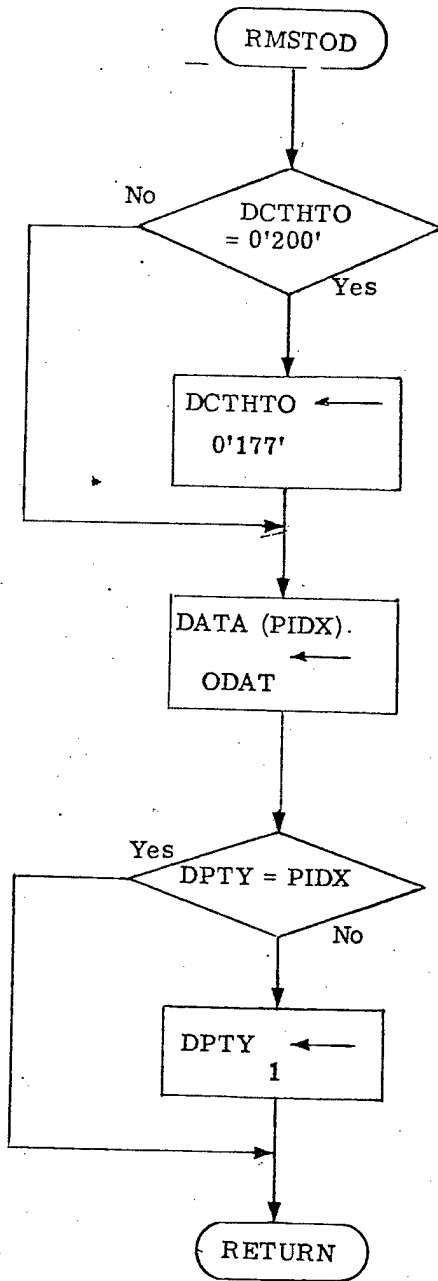

Figure 10. Store ODAT (RMSTOD)

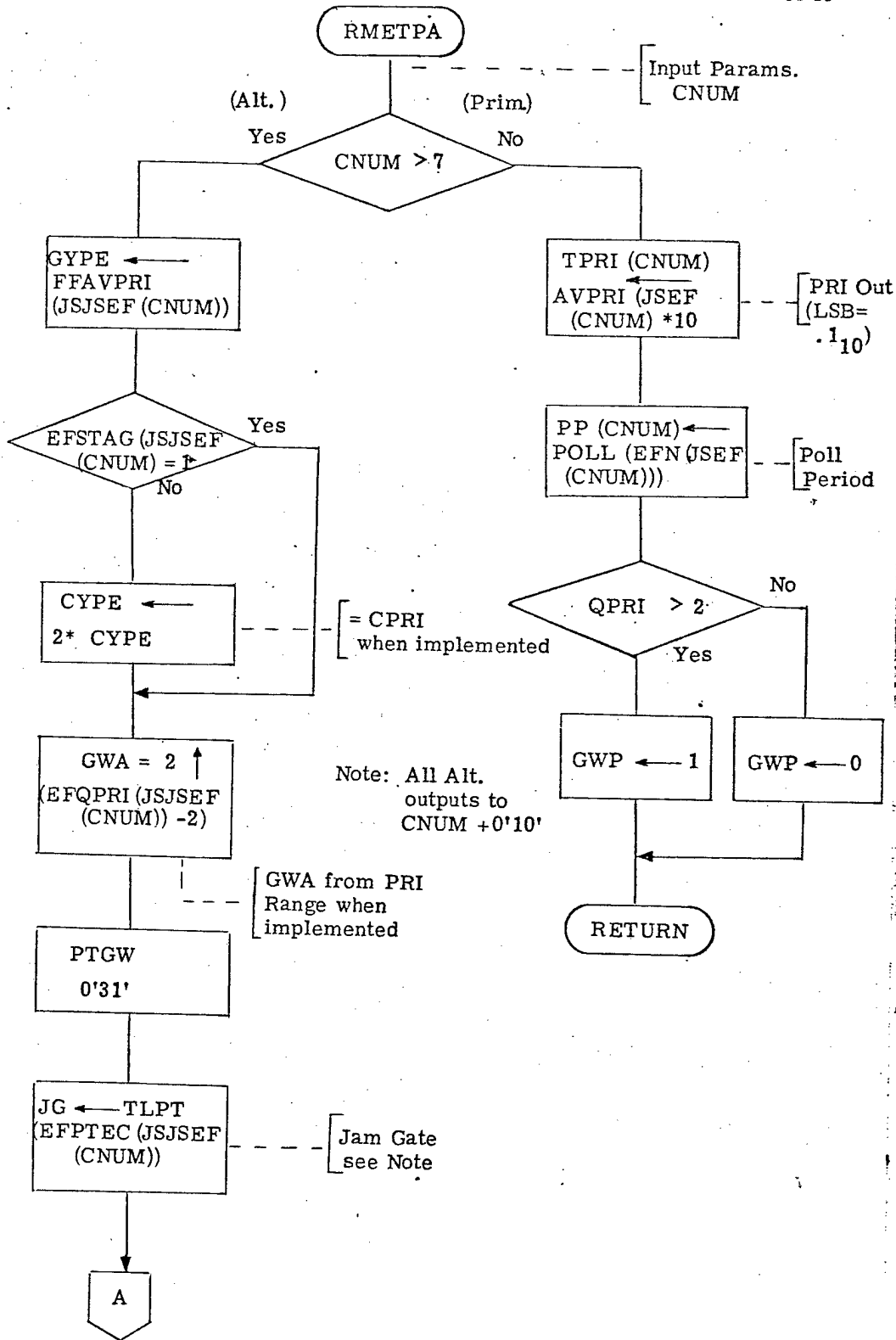

Figure 11. Emitter Tracker Parameters (RMETPA)

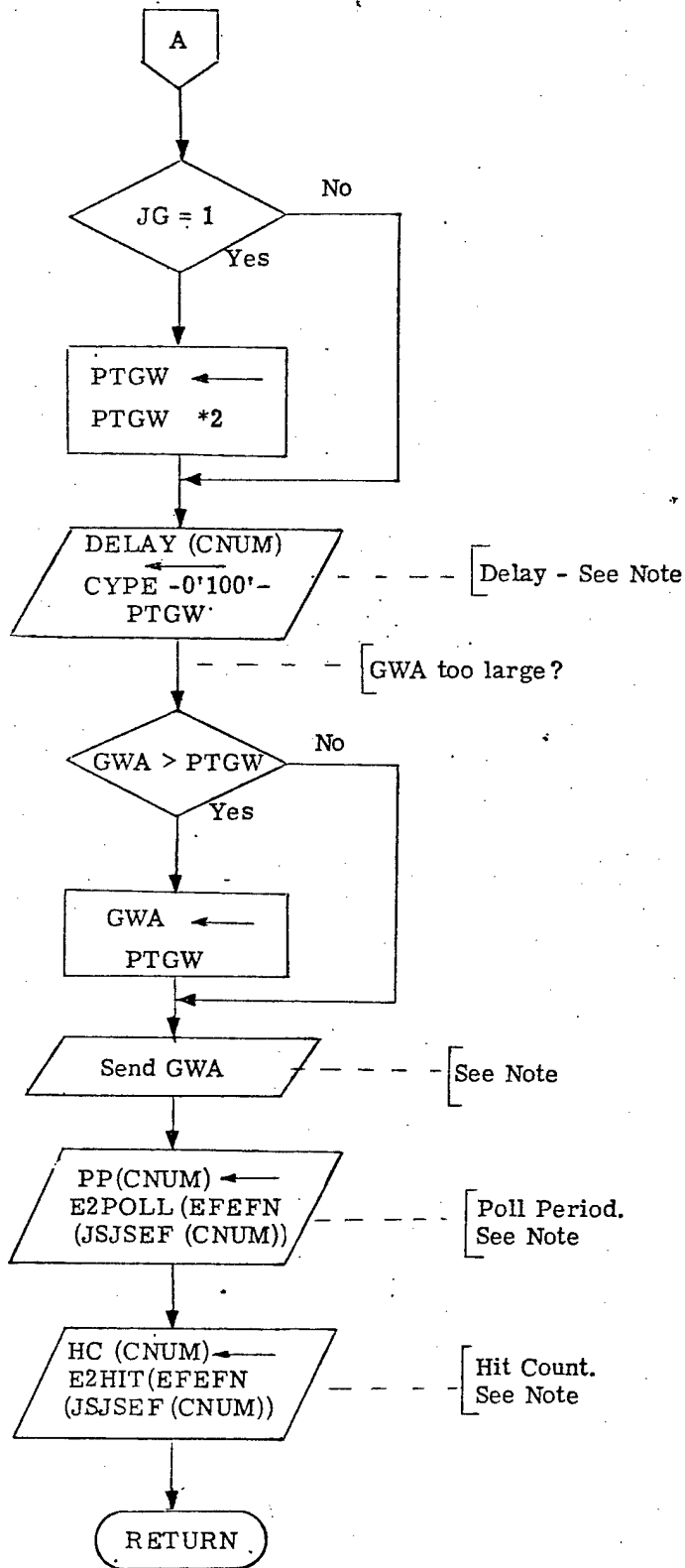

Figure 11. -continued-

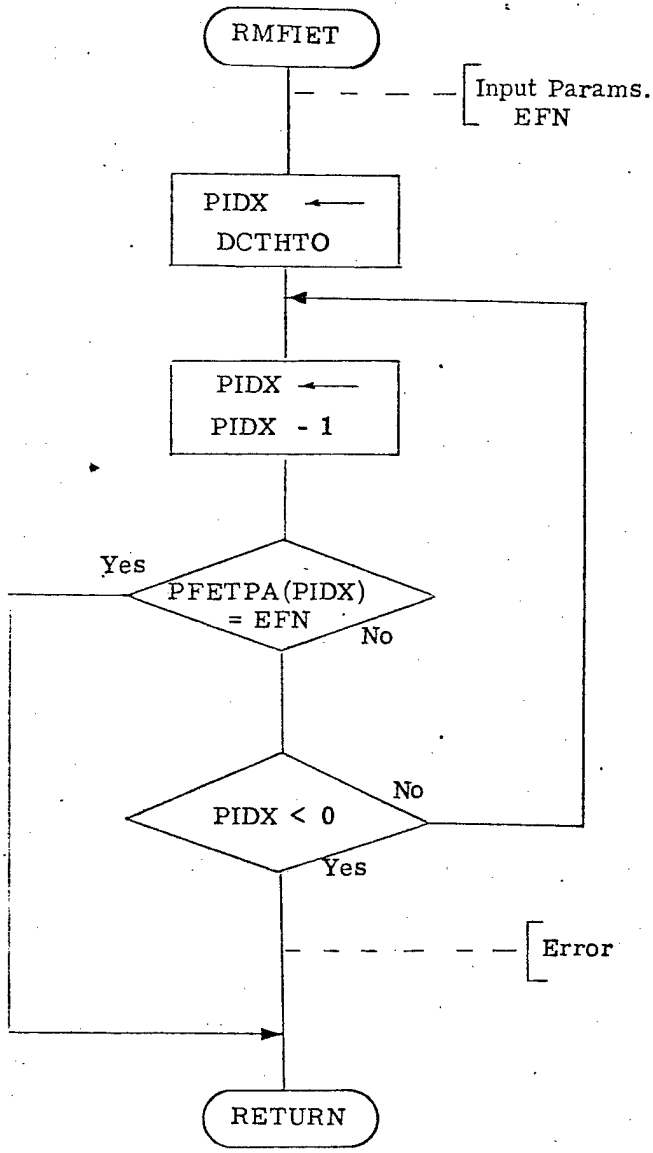

Figure 12. Find ETF Number (RMFIET)

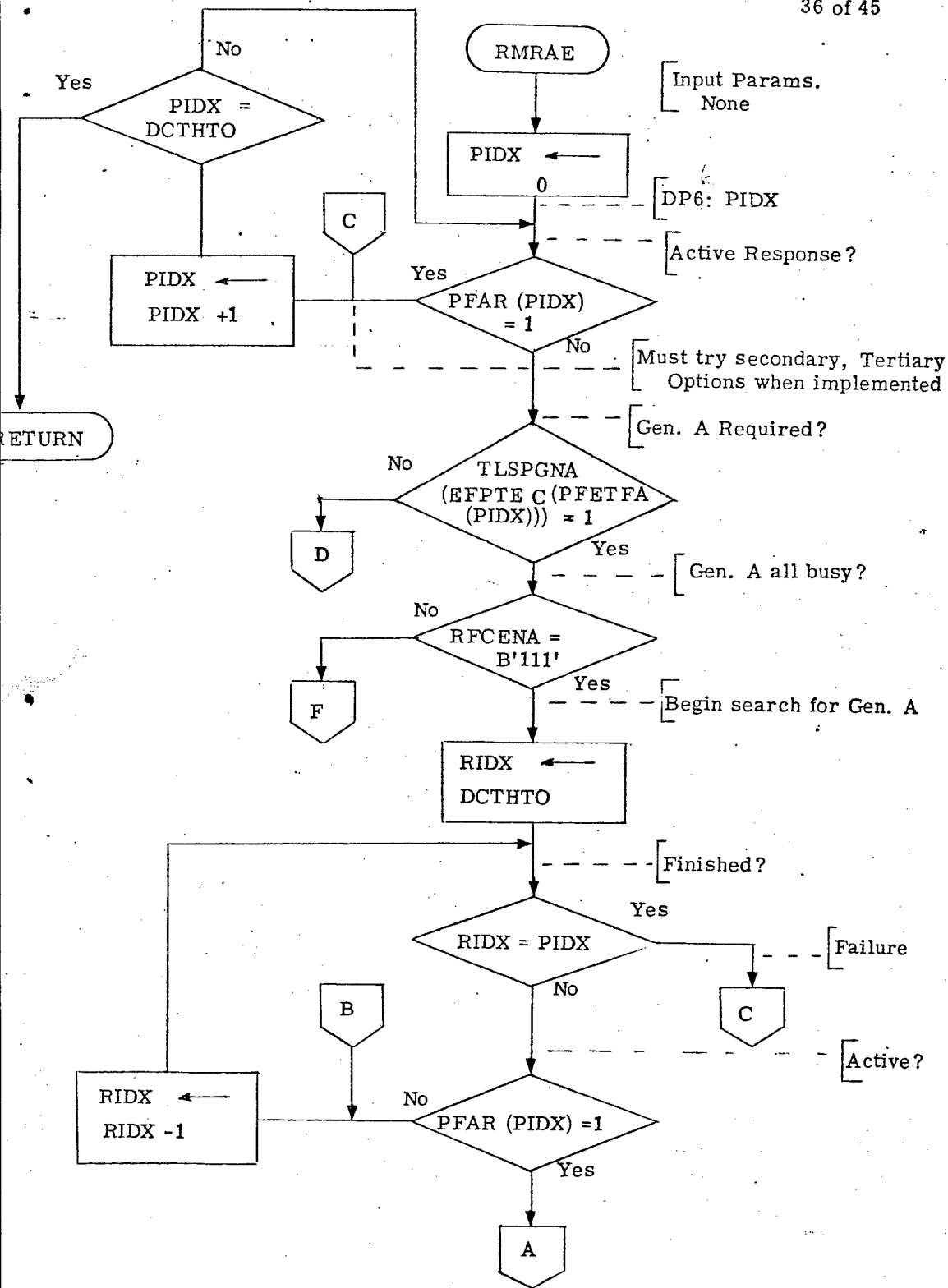

Figure 13. Resource Assessment (RMRAE)

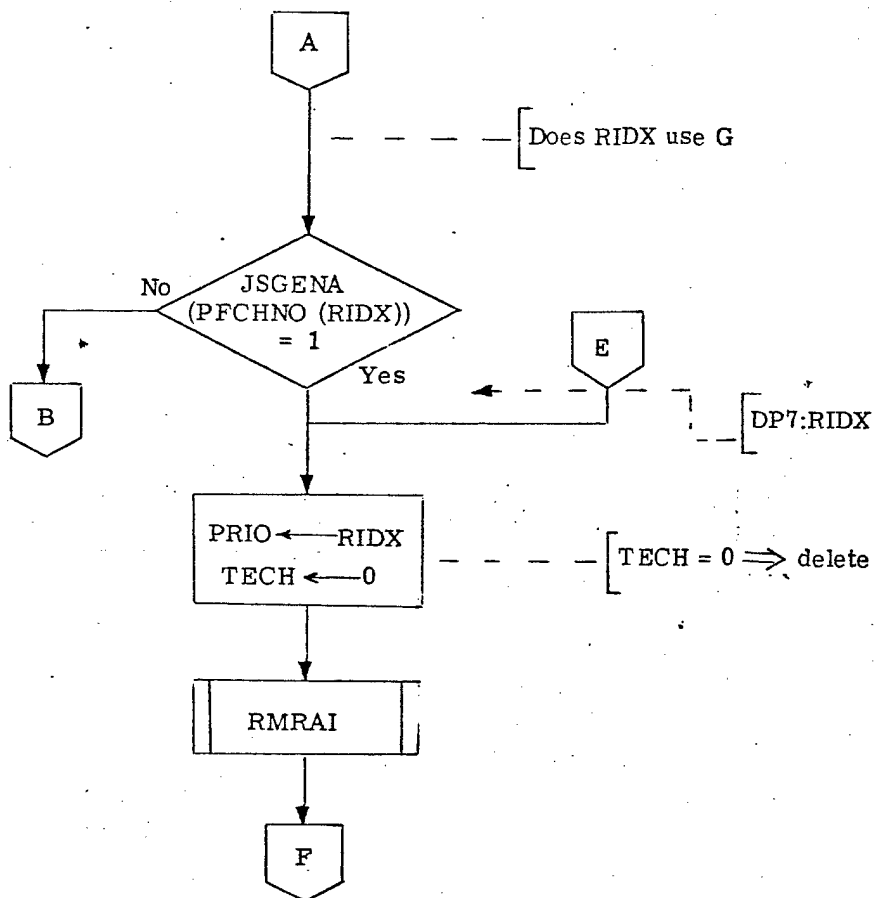

Figure 13. -continued-

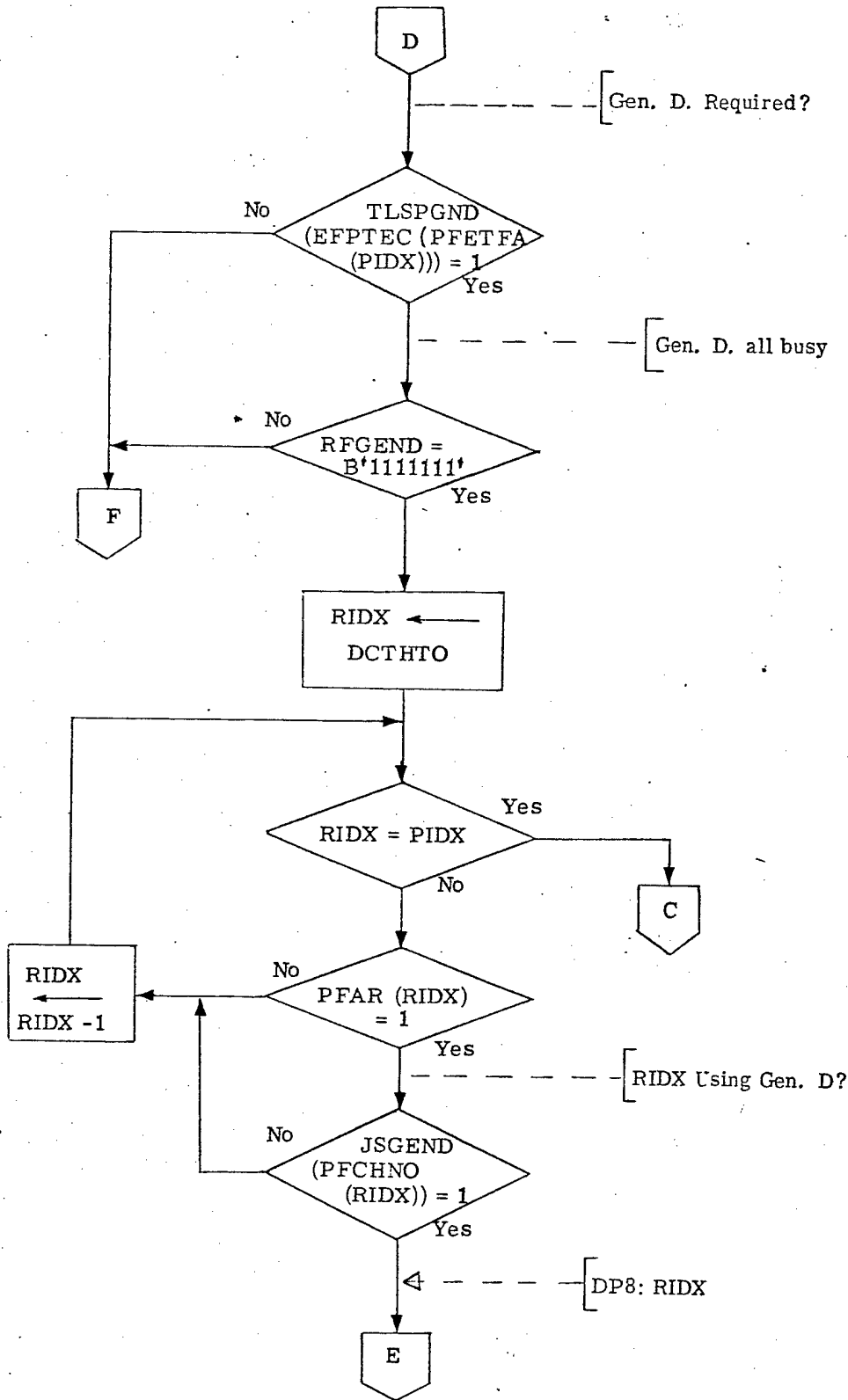

Figure 13. -continued-

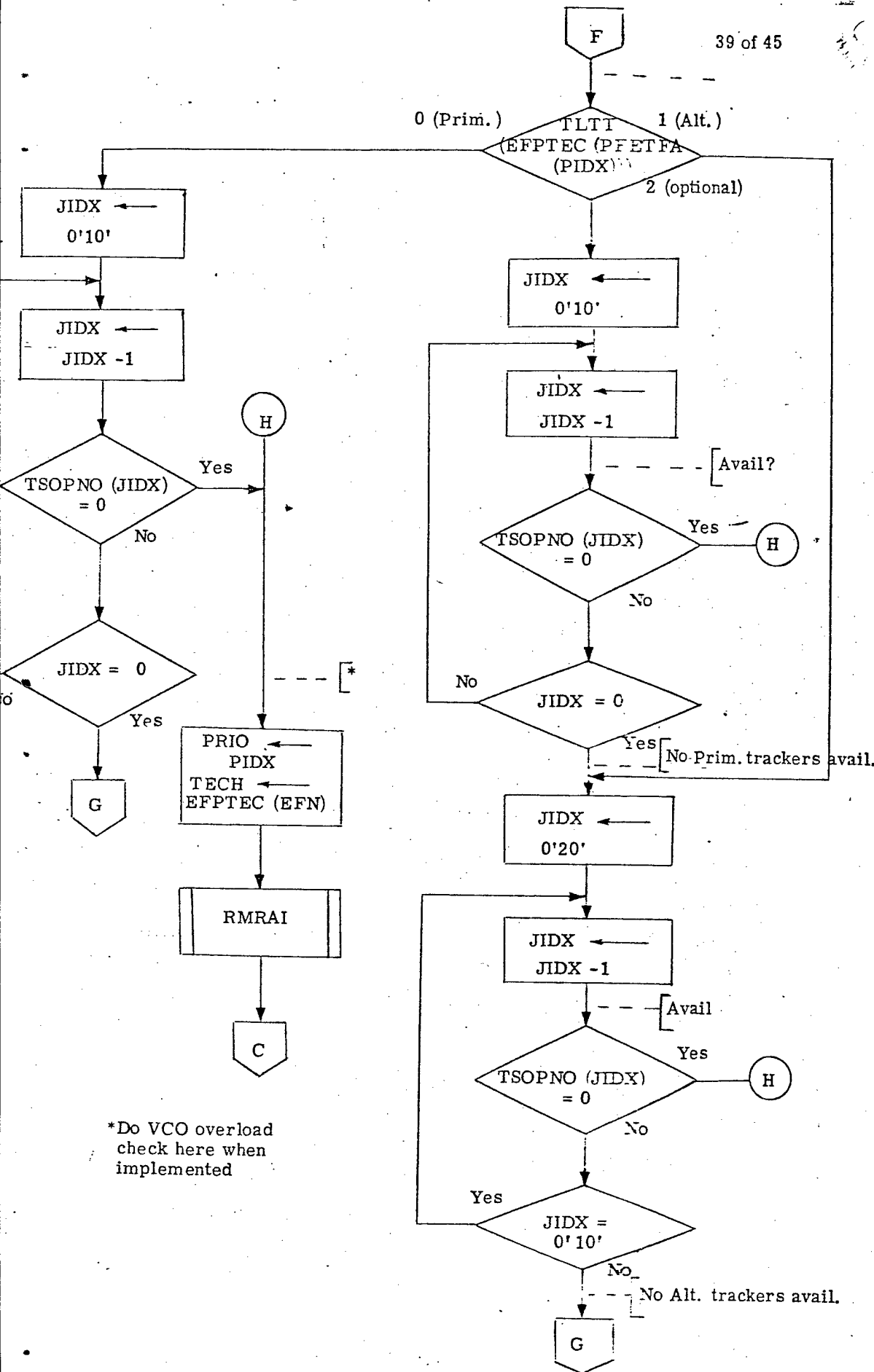

Figure 13. -continued-

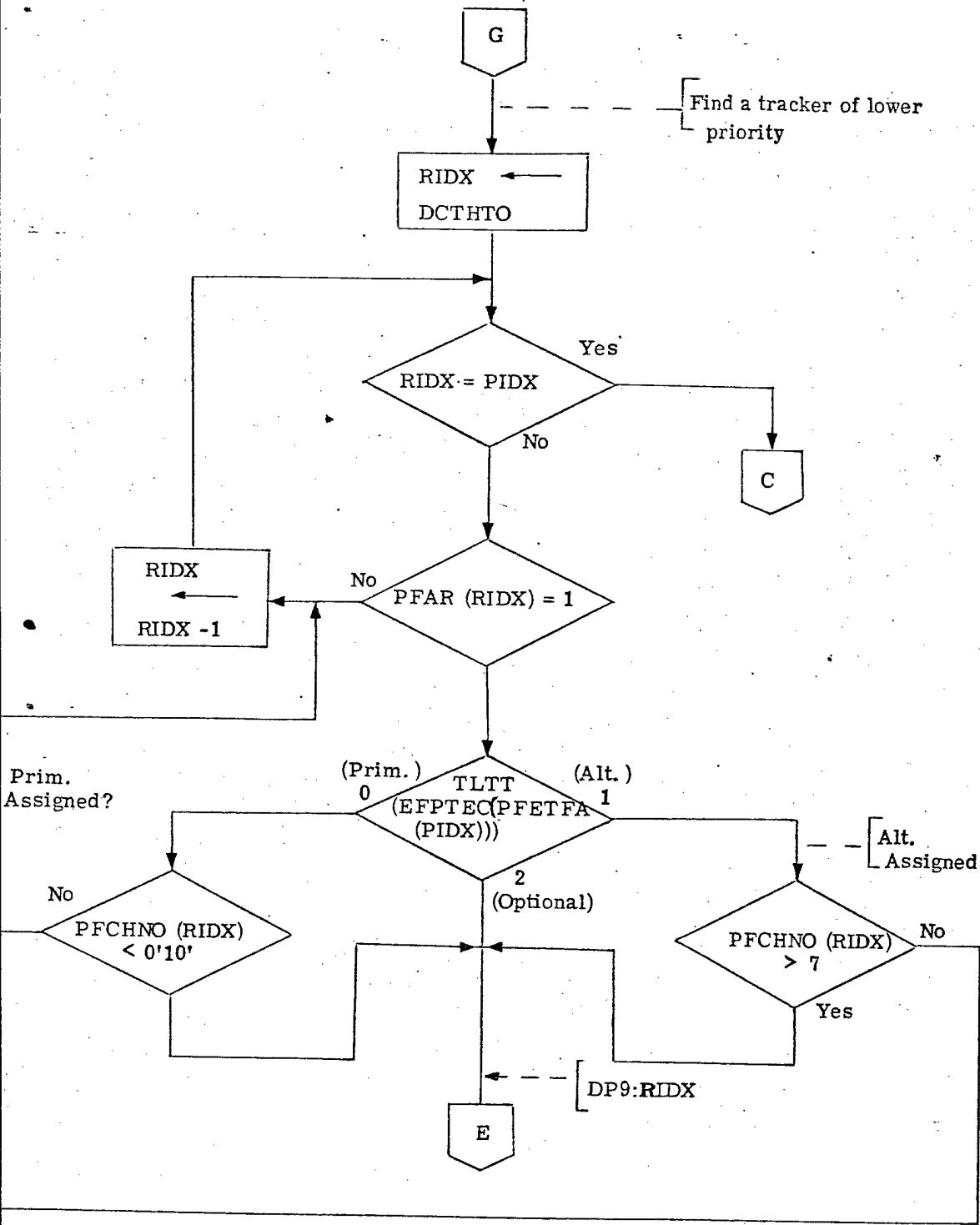

Figure 13. -continued-

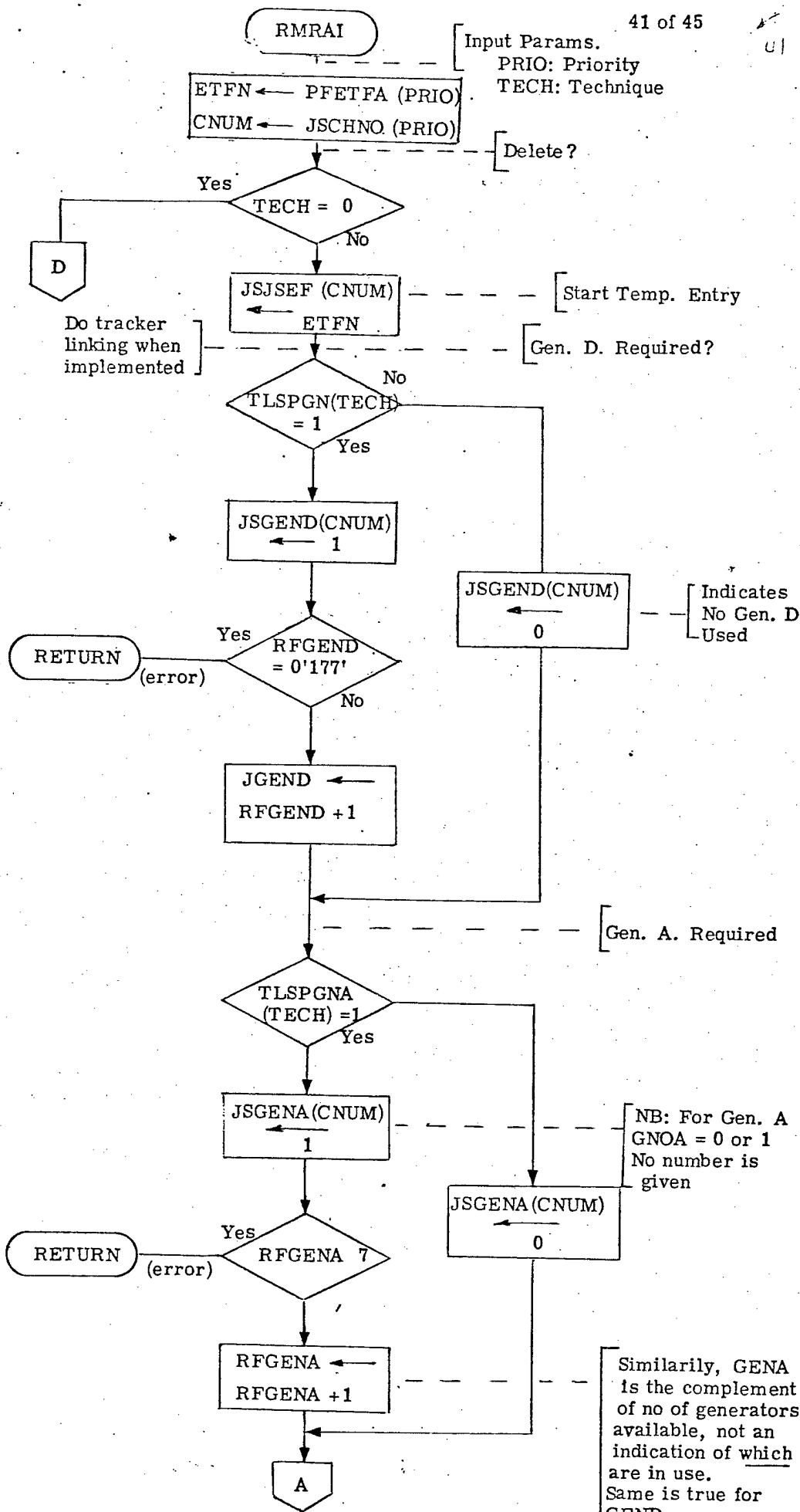

Figure 14. Resource Assignment (RMRAI)

3.3 COMPUTER SUBPROGRAM ENVIRONMENT

3.3.1 Tables

<u>Mnemonic</u>	<u>Name</u>	<u>Purpose</u>	<u>Size</u>	<u>Structure</u>
ATBL	ACN Table	TG Programming	4 x 26 x 5	Freq x Az x 5

3.3.2 Variables

<u>Mnemonic</u>	<u>Name</u>	<u>Purpose</u>	<u>Structure</u>
CNUM	Channel Number	Resource Assignment	JSF Address
CYPE	Cycle Period	ET Program	LSB = 1 μ s
EFN	Emitter File No.	ETF Reference	ETF Address
ETFN	Emitter File No.	ETF Reference	ETF Address
NLET	New Lethality	Emitter Assessment	Lethality
NPTY	New Priority	Priority Override	PF Address
ODAT	Old Data	RF Reordering	PF Entry
PRI0	Priority	Resource Assignment	PF Address
PTGW	Pretrigger W	ET Program	LSB = 1 μ s
TBNG	TG Bearing	T.G. Program	Azimuth
TECH	Technique	Option Assignment	TL Address

RAYTHEON

RAYTHEON COMPANY
LEXINGTON, MASS. 02173

CODE IDENT NO.
49956

SPEC. NO.
53959-GT-0752

SHEET
43 OF 45 REV

3.3.4 Flags

<u>Mnemonic</u>	<u>Name</u>	<u>Purpose</u>	<u>Structure</u>
DOPT	Delta Option	Resource Assessment	1 = yes
DPTY	Delta Priority	Resource Assessment	1 = yes
RALL	Return All	Priority Return	1 = yes

3.3.5 Indexes

<u>Mnemonic</u>	<u>Name</u>	<u>Purpose</u>
DIDX	Difference Index	PF Reference
JIDX	JSF Index	JSF Reference
PIDX	Priority Index	PF Reference
RIDX	R Index	PF Reference
XIDX	X Index	PF Reference

3.3.6 Common Data Base Reference

<u>Mnemonic</u>	<u>File</u>	<u>Mnemonic</u>	<u>File</u>
DCTHTO	DCSF	EFQPRI	ETF
E2FA	EL	EFSTAG	ETF
E2HIT	EL	EFTESO	ETF
E2POLL	EL	JSGENA	JSF
E2TEC 1	EL	JSGEND	JSF
E2PTRA	EL	JSJSEF	JSF
E2PTRB	EL	JSOPNO	JSF
E2PTRC	EL	PFAR	PF
E2PTRD	EL	PFCHNO	PF
EFAVPI	ETF	PFETFA	PF
EFAZ	ETF	PFPRSO	PF
EFELN	ETF	RFGENA	RF
EFENG	ETF	RFGEND	RF
EFFREQ	ETF	TLPT	TL
EFLETH	ETF	TLSPGN	TL
EFPTEC	TF	TLTT	TL

3.4 Input/Output Formats

Formats for SC Input/Output to external hardware is documented in detail in the IEWS ICD. However, the following symbols from the flow charts have different names in the ICD.

<u>Symbol</u>	<u>ICD</u>	<u>Equivalent</u>
CHNS	53959 -JK - 1003	JAM ID
CNUM	-JF - 1201	CHAN
CNUM	-HM - 0410	CHAN
DELAY	-JK - 1201	Delay + 2^9 x Clock
ETFN	-JK - 1002	SFN
GWA	-JK - 1201	GWA/2
GWP	-JK - 1201	GW
HC	-JK - 1201	Hit Count
TACN	-HM - 0410	ACN
TDIN	-JK - 1201	Primary DT x 2^8 + alternate DT
TENO	-HM - 0410	TECH NO.
TFRQ	-HM - 0410	FREQ
TPRI	-JK - 1201	PRI Out

Messages from the EXEC to RM are as follows:

<u>Message</u>	<u>Data</u>
Update	EFN
Priority Override	NPTY
Priority Return	EFN
	RALL
ET Interrupt	TDIN

The only message from RM to the EXEC is SS Message, and it shall include WORD 1 and WORD 2.