

# LOAN DOCUMENT

PHOTOGRAPH THIS SHEET

DTIC ACCESSION NUMBER

LEVEL

INVENTORY

DOCUMENT IDENTIFICATION

DISTRIBUTION STATEMENT

ACCESSIONION	
NTIS	GRAM <input checked="" type="checkbox"/>
DTIC	TRAC <input type="checkbox"/>
UNANNOUNCED	<input type="checkbox"/>
JUSTIFICATION	
BY	
DISTRIBUTION/	
AVAILABILITY CODES	
DISTRIBUTION	AVAILABILITY AND/OR SPECIAL
A-1	

DISTRIBUTION STAMP

Reproduced From  
Best Available Copy

19981223 013

DATE RECEIVED IN DTIC

REGISTERED OR CERTIFIED NUMBER

PHOTOGRAPH THIS SHEET AND RETURN TO DTIC-FDAC

H  
A  
N  
D  
L  
E  
  
W  
I  
T  
H  
  
C  
A  
R  
E

UNCLASSIFIED

NO DISTRIBUTION  
STATEMENT

NADC

Tech. Info.

APPENDIX 8

RMP DISPLAY & CONTROL MODULE  
FINAL SOFTWARE REPORT  
DATA ITEM NO. A005

**INTEGRATED ELECTRONIC WARFARE SYSTEM  
ADVANCED DEVELOPMENT MODEL (ADM)**

PREPARED FOR:

NAVY AIR DEVELOPMENT CENTER  
WARMINSTER, PENNSYLVANIA

CONTRACT N62269-75-C-0070

7800987-9



ELECTROMAGNETIC  
SYSTEMS DIVISION

1 OCTOBER 1977

UNCLASSIFIED

HC  
12-18-78

APPENDIX 8  
DISPLAY/CONTROL MANAGEMENT SOFTWARE DESIGN SPECIFICATION  
FINAL SOFTWARE REPORT  
DATA ITEM A005

INTEGRATED ELECTRONIC WARFARE SYSTEM (IEWS)  
ADVANCED DEVELOPMENT MODEL (ADM)

Contract No. N62269-75-C-0070

Prepared for:  
Naval Air Development Center  
Warminster, Pennsylvania

Prepared by:  
RAYTHEON COMPANY  
Electromagnetic Systems Division  
6380 Hollister Avenue  
Goleta, California 93017

1 OCTOBER 1977



**RAYTHEON**RAYTHEON COMPANY  
LEXINGTON, MASS. 02173

CODE IDENT NO.

49956

SPEC NO.

53959-GT-0753

SHEET  
2 OF 50

REV

## TABLE OF CONTENTS

<u>Section</u>	<u>Title:</u>	<u>Page</u>
1.0	SCOPE	3
1.1	Identification	3
1.2	Subprogram Tasks	4
2.0	REFERENCE DOCUMENTS	5
2.1	Performance Specification	5
2.2	Program Design Specification	6
2.3	Data Base Design Document	6
2.4	Miscellaneous Documents	6
3.0	REQUIREMENTS	7
3.1	Display & Controls (DCDR)	7
3.2	Subprogram Flow Diagrams	15
3.3	Computer Subprogram Environment	45
3.4	Input/Output Formats	50

## 1.0 SCOPE

The SC shall control the IEWS display and shall respond to operator requests. The D/C consists of a polar symbolic display, an alphanumeric display and several indicators and controls. The SC shall maintain the polar display by periodically sending to the D/C a threat descriptor for each of 64 angle cells, in one of several modes chosen by the operator. The SC shall maintain the alphanumeric display by sending the threat parameters for emitters requested by the operator. The SC shall pass to the display, several indications of environment status and shall pass to other SC modules, operator requests for changes in their operation. The D/C will be capable of operating in several modes (some of them simultaneously).

## 1.1 IDENTIFICATION

The names of the subroutines described in this document and their mnemonics are shown in Table 1.

TABLE 1

Subroutine	Mnemonic
Display and Controls Driver	DCDR
Status	DCSTA
A/N Status	DCANST
Polar Status	DCPOST
Keyboard Status	DCKBST
Polar Update	DCPOU
Find Emitter	DCFIEM
Chain Processing	DCCHPR
Convert/Send Data	DCCSDT
A/N Update	DCANU
Modify List Mode Characters	DCMLMC
Display List Mode-Finish	DCDLF
Display Parameter Mode Characters	DCDPMC
Send Headers	DCSEHE
Choose Test Emitters	DCCHTE
Choose List Emitters	DCCHLE
Display List Mode Characters	DCDLC
Send First Line	DCSEFL
Convert to Decimal/ASCII	DCCODA

1.2 SUBPROGRAM TASKS

The functions to be performed by these routines are shown in Table 2.

TABLE 2

Function	Description	Routines
Operator Commands	The status of all D/C controls shall be read once every 100 ms. Changes in the states of certain controls shall initiate processing to change display operation, to change the hook ID, and to specify ETF entries displayed in the list mode. The D/C data from the last update shall be stored in the D/C status file. However, the states of all D/C controls except system test shall be ignored while the display is in the test mode.	DCDR DCSTAT DCANST DCPOST DCKBST
Polar Display	The polar display shall be updated once every second or whenever there is a D/C mode change. Parameters shall be displayed for the highest lethality ETF entry at each of 64 bearings. In addition, several parameters shall be displayed which summarize the status of all ETF entries at each bearing.	DCDR DCPOU DCFIEM DCCHPR DCCSDT
A/N Display	The AN display shall be updated once every 10 seconds or whenever there is a D/C mode change (Refer to 3.3.6.1.2). In the parameter mode, parameters shall be displayed for the ETF number designated by hook TF. In the list mode, parameters shall be displayed for up to eight emitters designated by Page.	DCDR DCANU DCMLMC DCDLF DCDPMC DCSEHE DCCHTE DCDLC DCSEFL DCCODA
Indicators	The D/C Unengaged indicator shall be updated once every second.	DCDR DCPOU DCCHPR DCCSDT

2.0 REFERENCE DOCUMENTS

The following documents form a part of this specification to the extent specified herein. In the event of conflict, the requirements of this specification shall govern.

2.1 PERFORMANCE SPECIFICATION

The Performance Specification for this software is Raytheon Document Number 061290529, Computer Program Performance Specification for System Controller Unit. The applicable paragraphs are shown in Table 3.

TABLE 3

Function	Applicable CPPS Paragraphs
Operator Commands	(only to sixth level) 3.3.6.1 3.3.6.1.1* 3.3.6.1.2* 3.3.6.1.2.1 3.3.6.1.2.2* 3.3.6.1.2.3* 3.3.6.1.2.4 3.3.6.1.2.5 3.3.6.1.2.6 3.3.6.1.2.7 3.3.6.1.2.7 3.3.6.1.2.8* 3.3.6.1.3*
Polar Display	3.3.6.2 3.3.6.2.1* 3.3.6.2.2* 3.3.6.2.2.1* 3.3.6.2.2.4* 3.3.6.2.2.5 3.3.6.2.3*
A/N Display	3.3.6.3* 3.3.6.3.1* 3.3.6.3.2* 3.3.6.3.2.1 3.3.6.3.2.2 3.3.6.3.2.3 3.3.6.3.3

2.1 -continued-

Function	Applicable CPPS Paragraphs
Indicators	3.3.6.4* 3.3.6.4.1* 3.3.6.4.2* 3.3.6.4.3*

\*In part only.

2.2 PROGRAM DESIGN SPECIFICATION

The Design Specification for this software is Raytheon Document Number 53959-GT-0750, System Controller CPDS. All sections are applicable.

2.3 DATA BASE DESIGN DOCUMENT

The Data Base Design Document for this software is Raytheon Document Number 53959-GT-0751, System Controller CDBDD. All sections are applicable.

2.4 MISCELLANEOUS DOCUMENTS

The following miscellaneous documents shall govern the design of this software where applicable:

Display Control Unit Hardware Specification	53959-RA-0510
STE Hardware Specification	53959-KH-0610

### 3.0 REQUIREMENTS

#### 3.1 DISPLAY AND CONTROLS (DCDR)

The flow chart of subroutine DCDR is shown in Figure 1. This routine shall be called by the Executive every 100 ms. There shall be no input parameters. First, the status of the operator controls shall be checked by subroutine DCSTA. Then a 100-ms timer shall be incremented. If the timer has reached ten, or if DCSTA has indicated that an update is required (UPDM = 1), then the 100-ms timer shall be reset, a one-second timer shall be incremented, and the Polar Display shall be updated by subroutine DCPOU. If the 1-sec timer has reached ten, or if DCSTA has indicated that an update is required, or that a modification is required (MODI = 1), then the 1-sec timer shall be reset and the A/N display shall be updated by subroutine DCANU. Finally, control will be returned to the EXEC.

##### 3.1.1 Status (DCSTA)

The flow chart of subroutine DCSTA is shown in Figure 2. There shall be no input parameters. First, the Display and Control registers shall be read and the Update and Modification Flags (UPDM, MODI) initialized. Next, the status of System Test (DCSYTT) shall be checked. If the test is in progress or has been requested, then the status of that control shall be stored and control shall be returned to the calling routine. If the test is beginning or ending, then a System Test Begin or System Test End Message, respectively, shall be sent to the Exec. and UPDM shall be set. If System Test is not currently requested, then the status of controls relating to the A/N Display and the Polar Display shall be checked by subroutines DCANST (A/N Status) and DCPOST (Polar Status), respectively. The status of the keyboard shall then be checked by subroutine DCKBST (Keyboard Status), and the new status stored in the DCSF. Finally, control shall be returned to the calling routine.

### 3.1.1.1 A/N Status (DCANST)

The flow chart of subroutine DCANST is shown in Figure 3. There shall be no input parameters. A request for a change in DCPAGE (DCFWD or DCBACK, 0→1) shall cause DCPAGE to be incremented or decremented, respectively, by one (modulo DCTHTO - - Threat total) and shall cause UPDM to be set. (In this document the D/C input and the entries in the DCSF have been given the same name). "DCFWD 0→1" indicates that FWD is the DCSF (old FWD) is 0, and D/C (new FWD is 1.) A change in DCLIST shall cause UPDM to be set, and a change of DCLIST from 0 to 1 shall cause DCPAGE to be zeroed. A change of DCACQ from 0 to 1 while DCLIST is set shall cause DCHKID (Hook I. D.) to be replaced and the ETF number of the emitter at line DCLPTR (Line Pointer) on the A/N Display, and UPDM shall be set. If DCLPTR changes, then the old pointers shall be erased and new pointers inserted. Control shall then be returned to the calling routine.

### 3.1.1.2 Polar Status (DCPOST)

The flow chart of subroutine DCPOST is shown in Figure 4. There are no input parameters. If DCHOOK has changed from 0 to 1, then DCHKID (Hook I. D.) shall be replaced by the ETF number of the emitter displayed at bearing DCRPOS (Cursor) and UPDM shall be set. If DCEXP (Expand) has changed from 0 to 1, then DCEXAZ (Expand Azimuth) shall be replaced by the Azimuth of the cursor, and CDHKID shall be replaced by the ETF number of the emitter displayed at bearing DCEXAZ. If there has been any change in DCEXP, then UPDM shall be set. Control shall then be returned to the calling routine.

### 3.1.1.3 Keyboard Status (DCKBST)

The flow chart of subroutine DCKBST is shown in Figure 5. There shall be no input parameters. First, RALL (Return All) shall be reset. Then, if DCKB (Keyboard) has changed from 0 to 1, LKBE (Last Keyboard Entry - 2 BCD digits) shall be tested for 00 or 99. If LKBE is equal to zero, a Master Reset message shall be sent to the EXEC and UPDM shall be set. If LKBE=99, then Priority Return shall be indicated. All EFTESO (Technique Source) flags shall be reset, RALL shall be set in the ETF, a Priority Return Message shall be sent to the

EXEC, and UPDM shall be set. If TE (Technique Enter) has changed from 0 to 1, then MODI (Modification) shall be set and a Technique Override message shall be sent to the EXEC. Also, EFTESO shall be set for the ETF number at DCHKID, and EFPTEC for that ETF number shall be replaced by LKBE. If, on the other hand, LKBE = 99, then DCTESO (above) shall be reset. Finally, if DCPE (Priority Enter) changes from 0 to 1, then LKBE shall again be tested for 99. If the test is negative, then NPTY (new Priority) shall be replaced by LKBE and a Priority Override Message shall be sent to the EXEC and MODI shall be set. If LKBE = 99, then a Priority Return Message shall be sent to the EXEC, and MODI shall be set. Control shall then be returned to the calling routine.

### 3.1.2 Polar Update (DCPOU).

The flow chart of subroutine DCPOU is shown in Figure 6. There shall be no input parameters. First, LHDG (Last Heading) shall be replaced by HDNG (Heading). Then, DCCUID (Cursor I.D.) shall be replaced by the ETF number of the emitter at the current azimuth of the cursor. (During the entire polar update cycle the heading will be assumed to be fixed at LHDG). Next, AIDX shall be reset and ASGN shall be set (to be used in assignment of display bearing in the Expand Mode). Finally, subroutines DCFIEM and DCCSDT shall be called, and control shall be returned to the calling routine.

#### 3.1.2.1 Find Emitters (DCFIEM)

The flow chart of subroutine DCFIEM is shown in Figure 7. There shall be no input parameters. This subroutine shall simply call subroutine DCCHPR repetitively for all values of ETFN from 0 to 127. Control shall then be returned to the calling routine.

##### 3.1.2.1.1 Chain Processing (DCCHPR).

The flow chart of subroutine DCCHPR is shown in Figure 8. The only input parameter shall be ETFN (ETF number). First, several parameters shall be initialized, and processing shall continue only if the file is active (FACT = 1) and if no system test is in progress (STST = 0) or the file is a test file (DISP = 13), and

PLET (Platform Lethality) set equal to the Lethality of the ETF number given by ETFN. If EFENG (Engaged) is 0 for ETFN, then ENPL and ENAL (engaged-Platform and All) shall be reset. If DCEXP (Expand) = 0, then ETFN shall be compared to DCHKID and DCCUID (Hook I.D. and Cursor I.D.). If ETFN = DCHKID or DCCUID, the HKBG (Hook Bearing) or CUBG (Cursor Bearing), respectively, shall be replaced by the bearing of ETFN. If PLET = 0, then control shall be returned at this time to the calling routine. If not, then one of two branches shall be followed depending on DCEXP (Expand). If DCEXP = 0, then the following processing shall occur. If PLET is greater than the Lethality of the emitter currently designated for display at the Azimuth of ETFN, then the data for that Azimuth shall be replaced by the data for ETFN. This data includes Lethality, Type, Engaged, Naval, and ETFN, itself. If ANUM (Angle-Number) for that Azimuth is not equal to 2, then it shall be incremented by 1. Control shall then be returned to the calling routine. If, on the other hand, DCEXP = 1, then processing shall proceed as follows. If the Azimuth of ETFN is not equal to DCEXAZ (Expand Azimuth), then control shall be returned to the calling routine. Otherwise, the emitter shall be assigned Azimuth ARAZ (Artificial Azimuth) adjacent to Azimuths already assigned in this update. The data (above) for that Azimuth shall then be replaced by the data for ETFN. ETFN shall then be compared to DCHKID and DCCUID. If equal to either one, then HKBG or CUBG, respectively, shall be set equal to ARAZ. The indices which determine ARAZ (AIDX and ASGN) shall then be modified appropriately, and control shall be returned to the calling routine.

### 3.1.2.2 Convert and Send Data (DCCSDT)

The flow chart of subroutine DCCSDT is shown in Figure 9. There shall be no input parameters. AZMT (Azimuth) shall, first be set equal to 63. If ANUM of AZMT = 0, then all data for that Azimuth shall be set equal to zero, and processing shall proceed to the sending of data. If ANUM = 2, then ATYP (Angle-Type) for Azimuth AZMT shall be set equal to 15 (multiple). If ANUM = 1 and ATYP = 0, then ATYP shall be set equal to 14 (unknown). If ANUM = 1, ATYP = 1, and AENG (Angle-Engaged), for Azimuth AZMT = 1, then ATYP shall be set equal to 13 (Unengaged). BRNG (Bearing) shall be replaced by AZMT-LHDG (last

Heading) and data for AZMT shall be formatted and sent to bearing BRNG on the polar display. This process shall then be repeated for all other Azimuths, 62-0. Finally, ENAL (Engaged-All) shall be sent to the display to determine the state of the Engaged indicator, and control shall be returned to the calling routine.

### 3.1.3 Alpha-Numeric Update (DCANU)

The flow chart of subroutine DCANU is shown in Figure 10. The only input parameter is MODI. If MODI is set, then the A/N mode shall be checked. If  $DCLIST \cdot DCACQ \cdot DCHOOK = 1$ , then the display is in the List Mode and subroutine DCMLC (Modify List Mode Characters) shall be called. If not, then subroutine DCDPMC (Display Parameter Mode Characters) shall be called. If  $MODI = 0$ , then DCSYTT (System Test) shall be examined. If DCSYTT is set, then subroutines DCCHTE (Choose Test Emitter) and DPMC shall be called. If  $DCSYTT = 0$  and List Mode is in effect, then DCCHLE (Choose List Emitters) and DC DLC (Display List Mode Characters) shall be called. If  $DCSYTT = 0$  and Parameter mode is in effect, then the displayed emitter (ANAIEF(0)) shall be set to DCHKID (Hook I.D.) and DCDPMC shall be called. Control shall then be returned to the calling routine.

#### 3.1.3.1 Modify List Mode Characters (DCMLMC)

The flow chart of subroutine DCMLMC is shown in Figure 11. There shall be no input parameters. The ETF number, whose parameters are to be displayed on line number 7, shall be compared to the ETF numbers in the Priority File (PFETF A). When it is found, ANPR (A/N Priority) shall be replaced by the priority of the given ETF number and subroutine DC DLF shall be called. This process shall be repeated for the remaining lines, 6-0, and control shall then be returned to the calling routine.

##### 3.1.3.1.1 Display List Mode Finish (DC DLF).

The flow chart for subroutine DC DLF is shown in Figure 12, where ADAT(i) is used to designate the ASCII representation of the ith character in line BIDX. The input parameters shall be BIDX (Line Index) and ANPR (A/N Priority).

If ANPR is negative (not in PF), then line BIDX shall be cleared and control shall be returned to the calling routine. Otherwise, ANPR shall be incremented by 1, converted to decimal/ASCII and sent to the display with the proper address. If PFPRSO (Priority Source) for the given PF entry is set, then an ASCII 'M' shall be sent to the display. Next, the proper Type symbols shall be determined for the given emitter, and those symbols shall be sent to the display. If EFNAVY is set for the given emitter, then an ASCII 'N' shall be sent. The Azimuth of the emitter shall then be determined and converted to degrees. The number shall then be converted to decimal/ASCII and sent to the display. If there is a current system response for this emitter (EFENG = 1), then the technique number shall be converted to decimal/ASCII and sent. If EFTESO (Technique Source) is set, then an ASCII 'M' shall be sent. In addition, all addresses in the the line which contain no characters shall be blanked. Control shall then be returned to the calling routine.

### 3.1.3.2 Display Parameter Mode Characters (DCDPMC)

The flow chart for subroutine DCDPMC is shown in Figure 13, where ADAT(?) is used to designate the ASCII representation of the ith character of line BIDX. There shall be no input parameters. The routine shall first send all required fixed field (units and labels) by calling subroutine DCSEHE. The frequency of the emitter designated in the AIF shall then be converted to decimal/ASCII and sent to the display. The Azimuth of the designated emitter shall then be converted to degrees, converted to decimal/ASCII and sent to the display. Amplitude shall be converted to negative dB, converted to decimal/ASCII and sent. PRI shall be converted and sent. Pulse width shall be converted to  $\mu s$ , decimal/ASCII (by way of a table) and sent. Similarly, type symbols shall be determined (from EFDISP) and sent. If EFNAVY is set for the designated emitter, an ASCII 'N' shall be sent. The Priority of the designated emitter shall then be determined by searching the PF for the designated ETF number. When it is found, the Priority shall be converted and sent. If PFPRSO (Priority Source) is set, then an ASCII 'M' shall also be sent. If there is a response to the emitter (EFENG), then the EFPTEC (Primary Technique) shall be converted and sent, and if EFTESO (Technique Source) is set, then an ASCII 'M' shall be sent also. Finally, if EFENG (Engaged) = 0, then

ASCII "UNENG" shall be sent, and all addresses which contain no characters shall be blanked. Control shall be returned to the calling routine.

#### 3.1.3.2.1 Send Headers (DCSEHE).

There shall be no input parameters to this subroutine. The routine shall send all fixed characters - labels, units, decimal points - that appear in the Parameter Mode, as specified in Figure 30 of Document No. 061290529.

#### 3.1.3.3 Choose Test Emitter (DCCHTE)

The flow chart for subroutine DCCHTE is shown in Figure 14. There shall be no input parameters. This routine shall search for a valid symbol (in the PIF) at bearings 31-34. If one is found, then the corresponding ETF number shall be put in the zero'th entry of the ANIF. Control shall then be returned to the calling routine.

#### 3.1.3.4 Choose List Emitters (DCCHLE)

The flow chart of subroutine DCCHLE is shown in Figure 15. There shall be no input parameters. FLPR (First List Priority) is first set to 8 times DCPAGE, and BIDX (List Index) to 7. The ETF number at FLPR + BIDX shall be put into the ANIF for line BIDX. This process shall be repeated for the other lines, 6-0. Finally, pointer symbols shall be sent to the display on line DCLPTR (Line Pointer), and control shall be returned to the calling routine.

#### 3.1.3.5 Display List Mode Characters (DCDLC)

The flow chart for subroutine DCDLC is shown in Figure 16. There shall be no input parameters. First, subroutine DCSEFL (Send First Line) shall be called. Then FLPR (First List Priority) shall be set equal to 7. ANPR shall be set equal to FLPR + BIDX and subroutine DCDLF shall be called. This process shall be repeated for other values of BIDX, 6-0, and control shall be returned to the calling routine.

### 3.1.3.5.1 Send First Line (DCSEFL).

There shall be no input parameters to this subroutine. The routine shall send all fixed characters - labels - that appear in the List Mode, as specified in Figure 31 of Document No. 061290529.

### 3.1.3.6 CONVERT TO DECIMAL/ASCII (DCCODA)

The only input parameter to subroutine DCCODA shall be BINI (Binary Input). This routine shall convert BINI to the ASCII representation of the equivalent five least significant decimal digits. The five numbers output shall be ADIG(i),  $i = 1, 2, 3, 4, 5$ , with ADIG(5) being the least significant. The first two leading zeros shall be suppressed by setting ADIG (1) and ADIG (2) equal to 0 when necessary. Control shall be returned to the calling routine.

**RAYTHEON**

RAYTHEON COMPANY  
LEXINGTON, MASS. 02173

CODE IDENT NO.

49956

SPEC NO.

53959-GT-0753

SHEET  
15 OF 50

REV

3.2 SUBPROGRAM FLOW DIAGRAMS

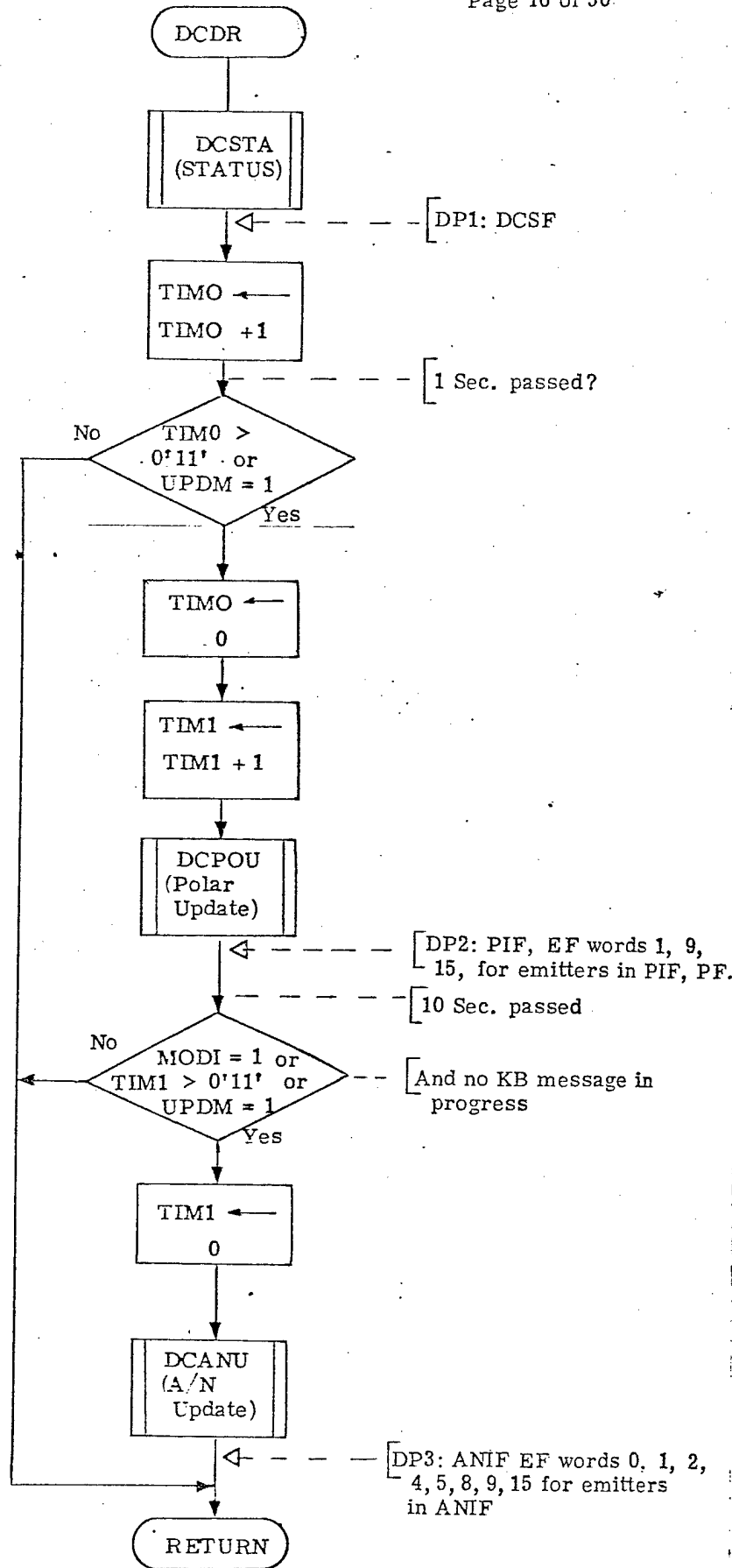

Figure 1. Display and Controls (DCDR)

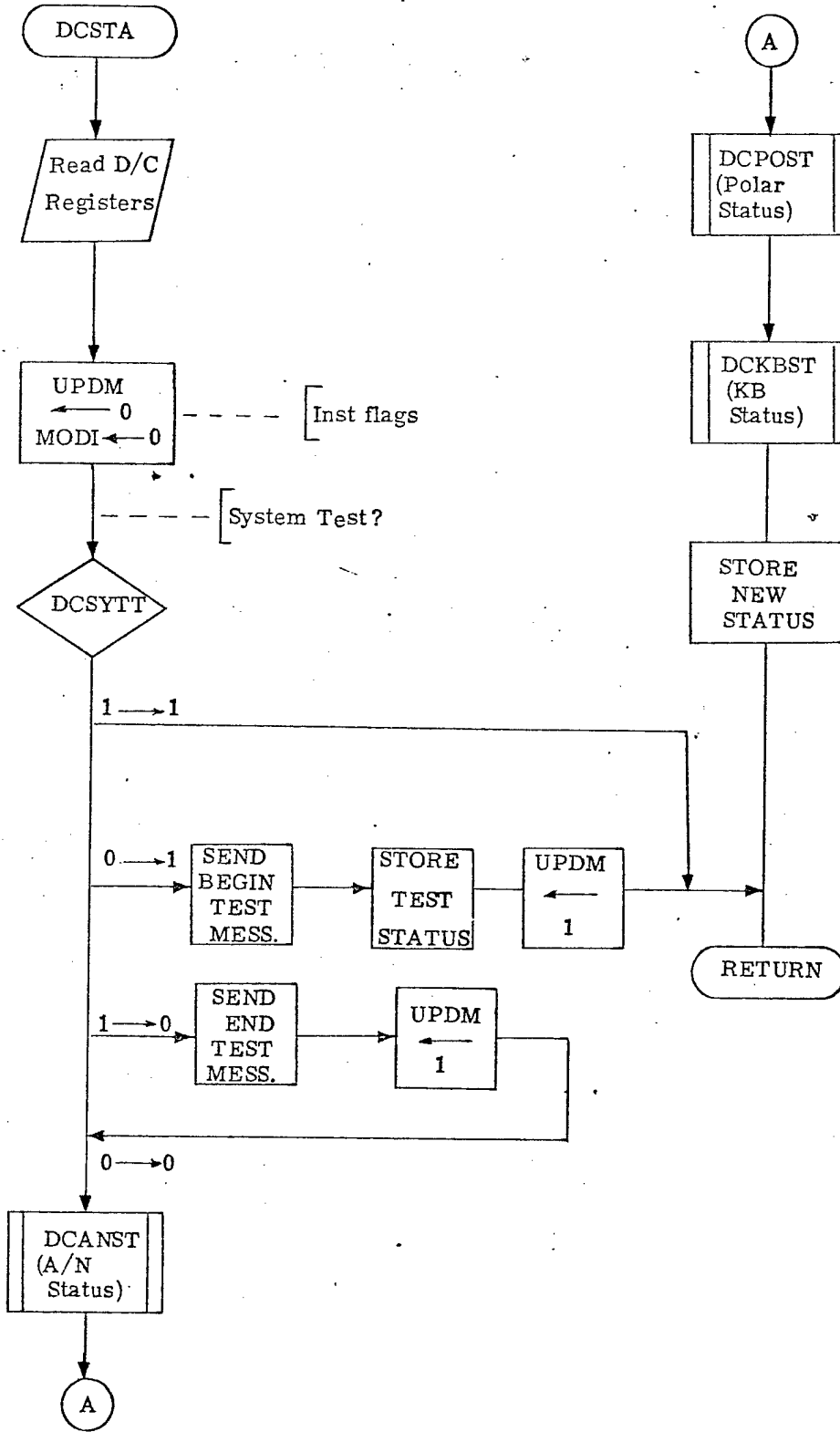

Figure 2. Status (DCSTA)

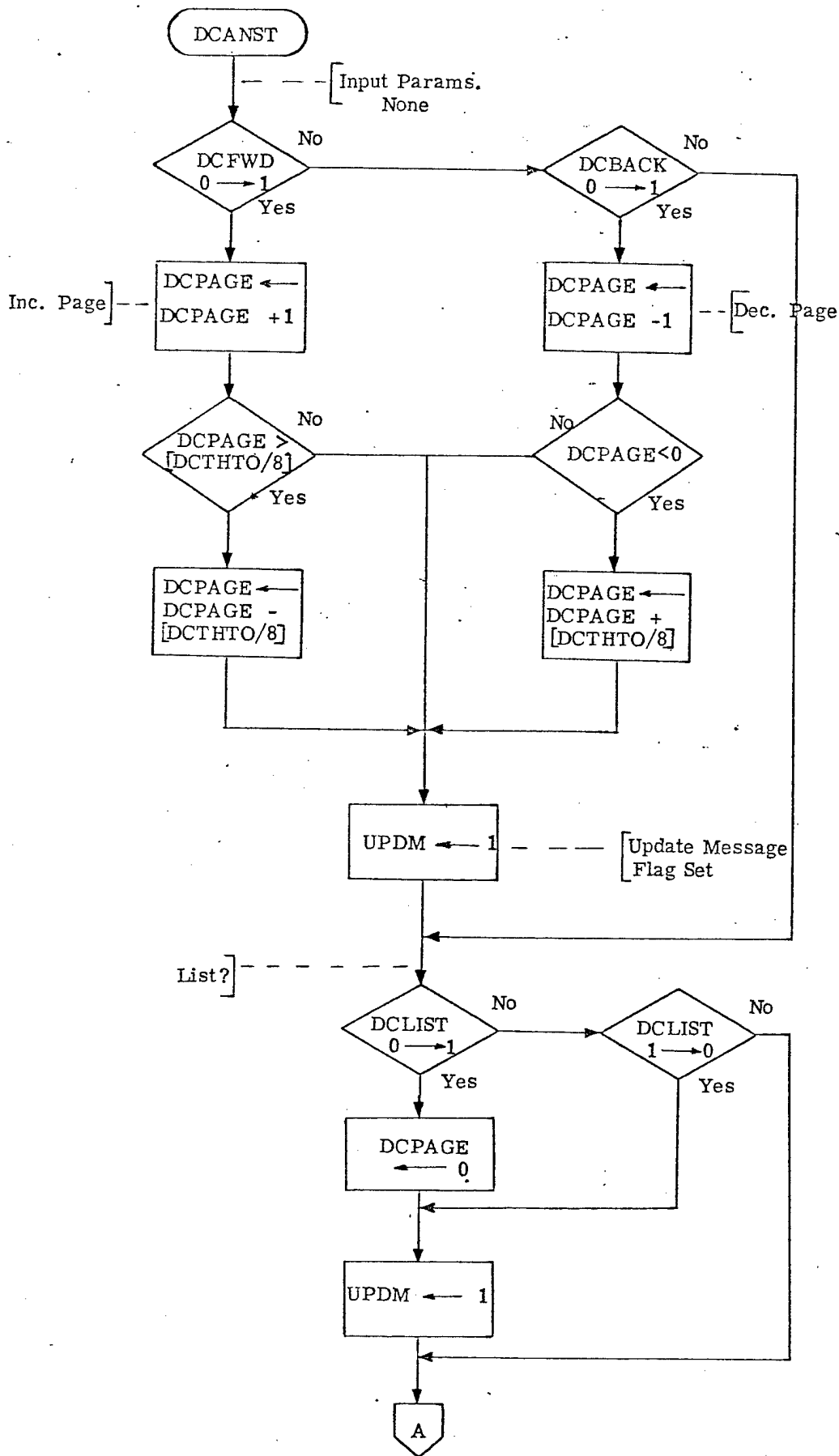

Figure 3. A/N Status (DCANST)

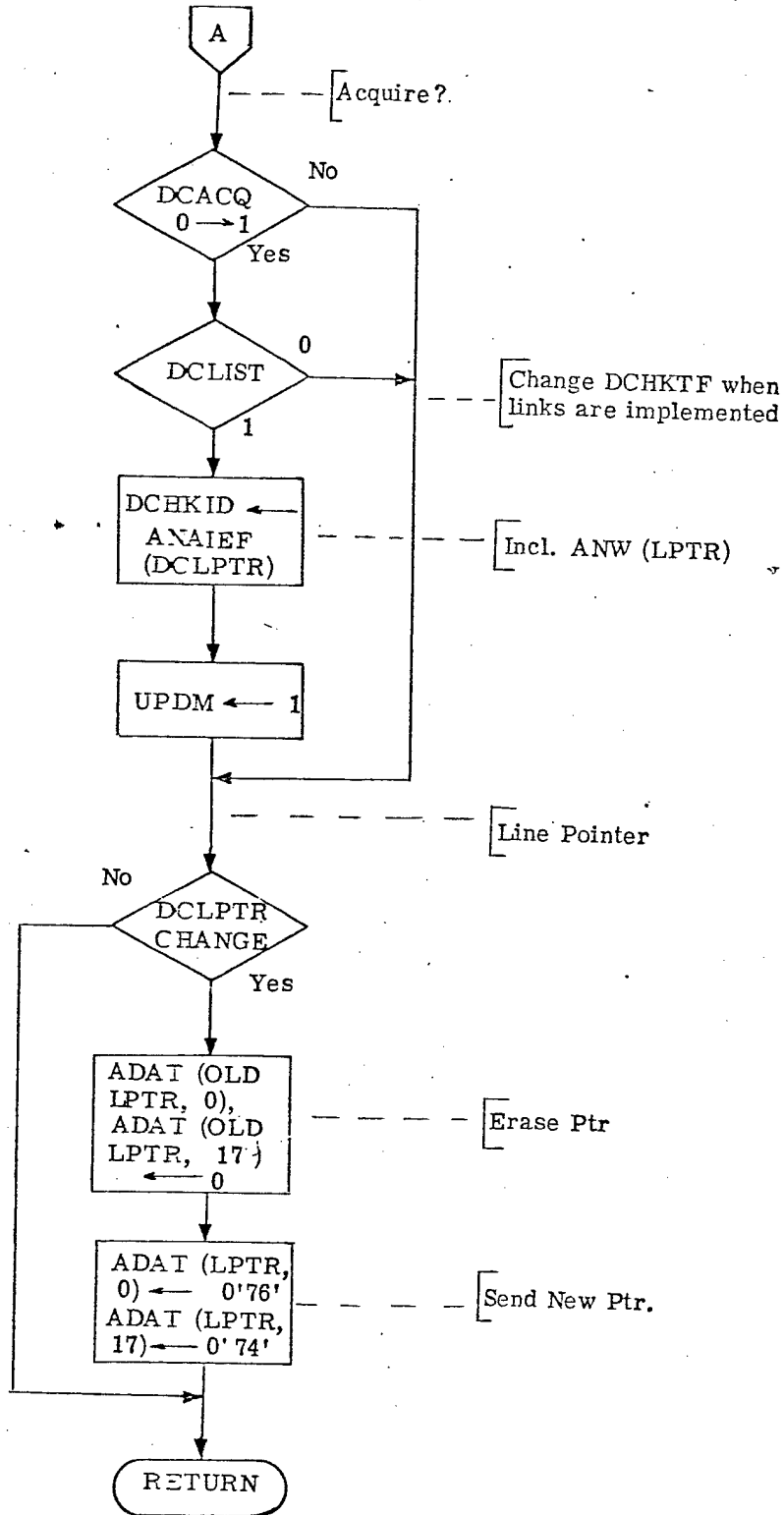

Figure 3. -continued-

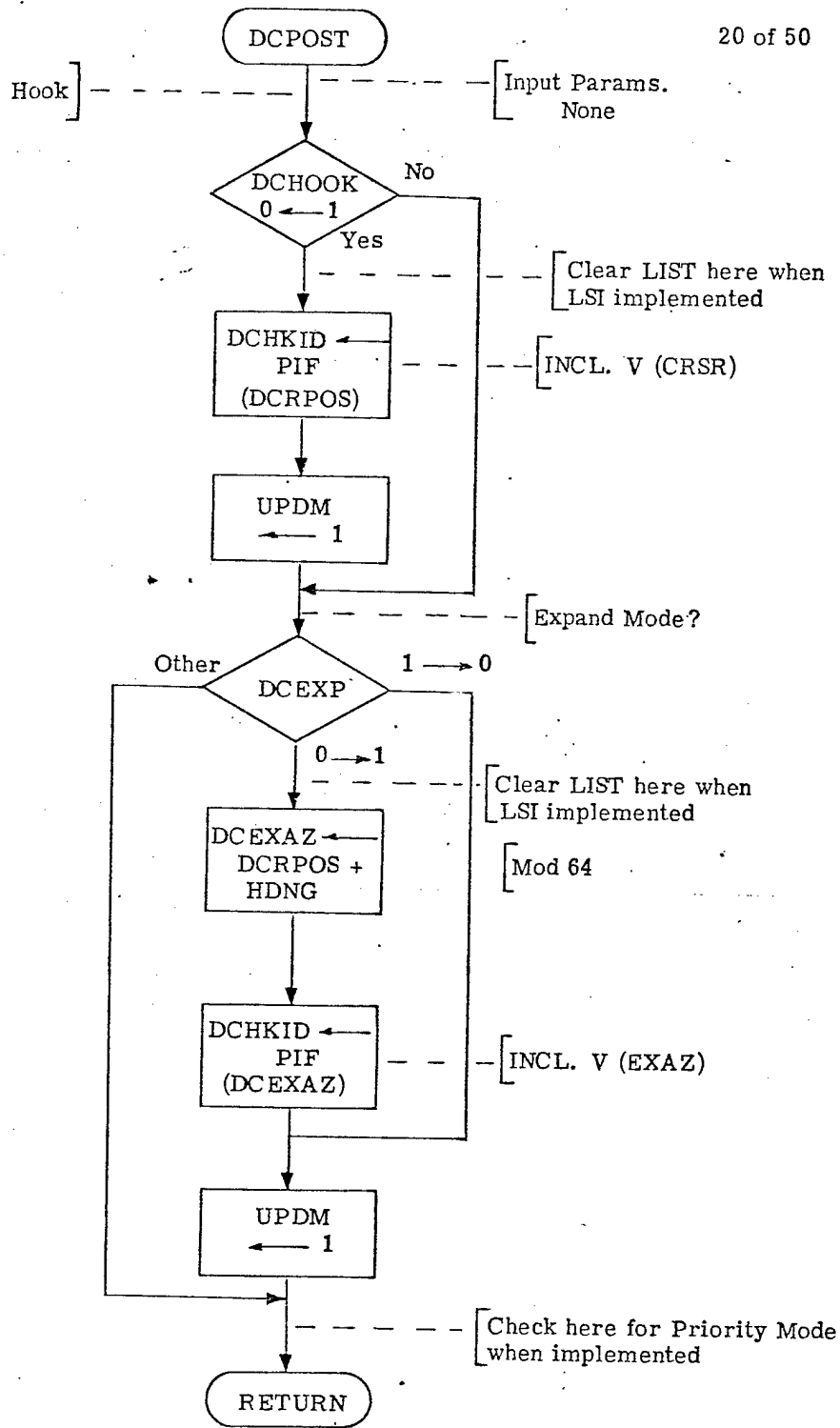

Figure 4. Polar Status (DCPOST)

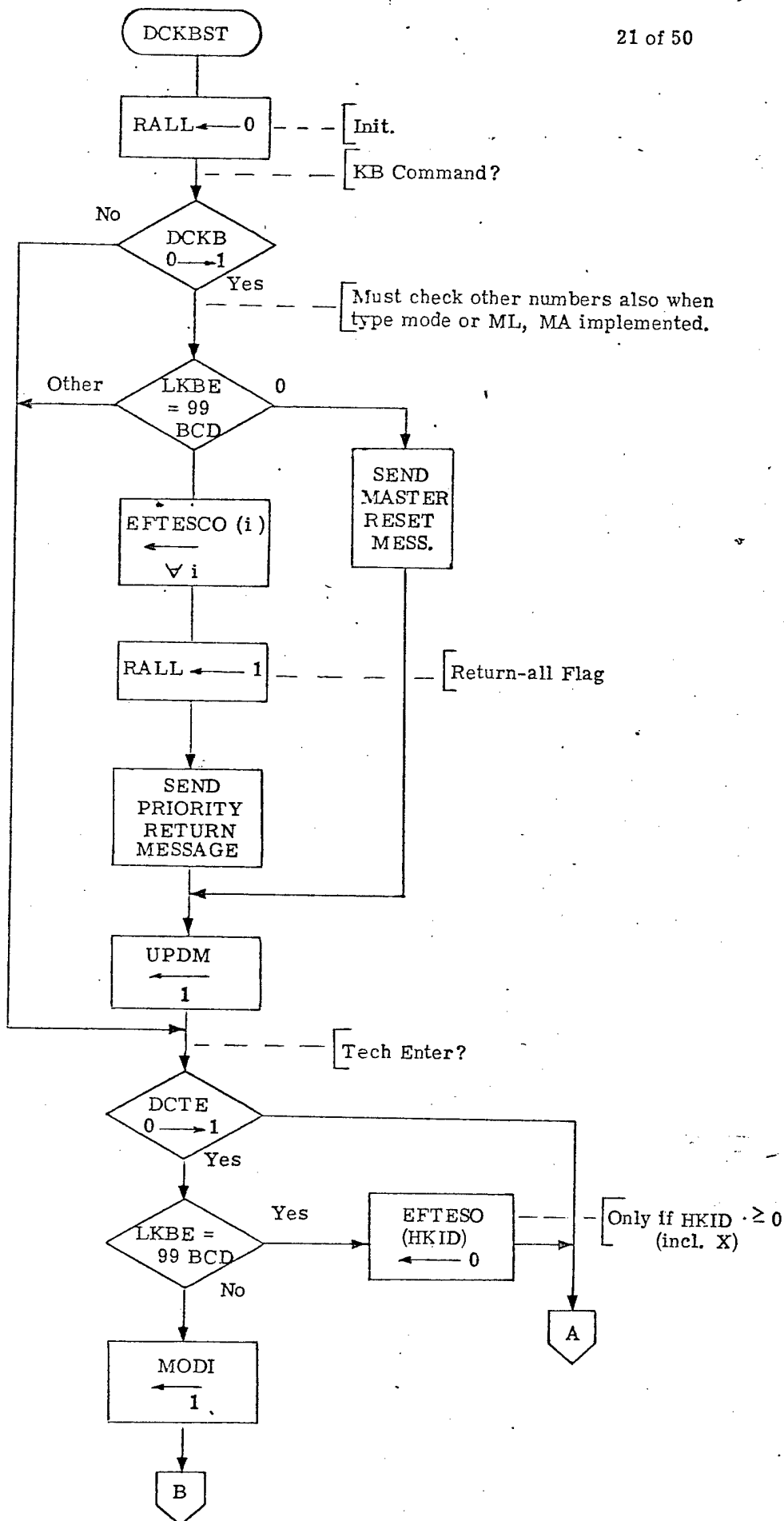

Figure 5. Keyboard Status (DCKBST)

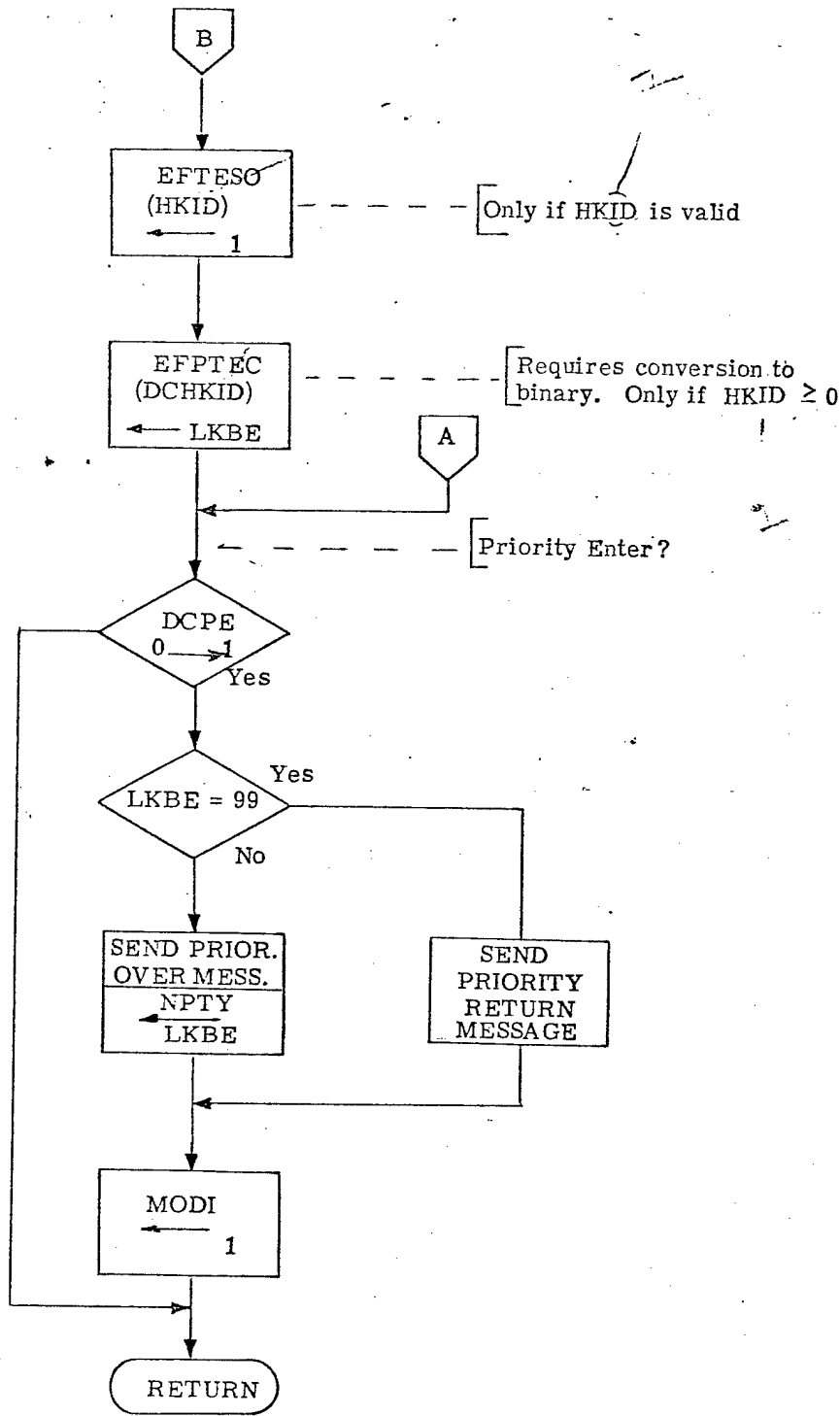

Figure 5. -continued-

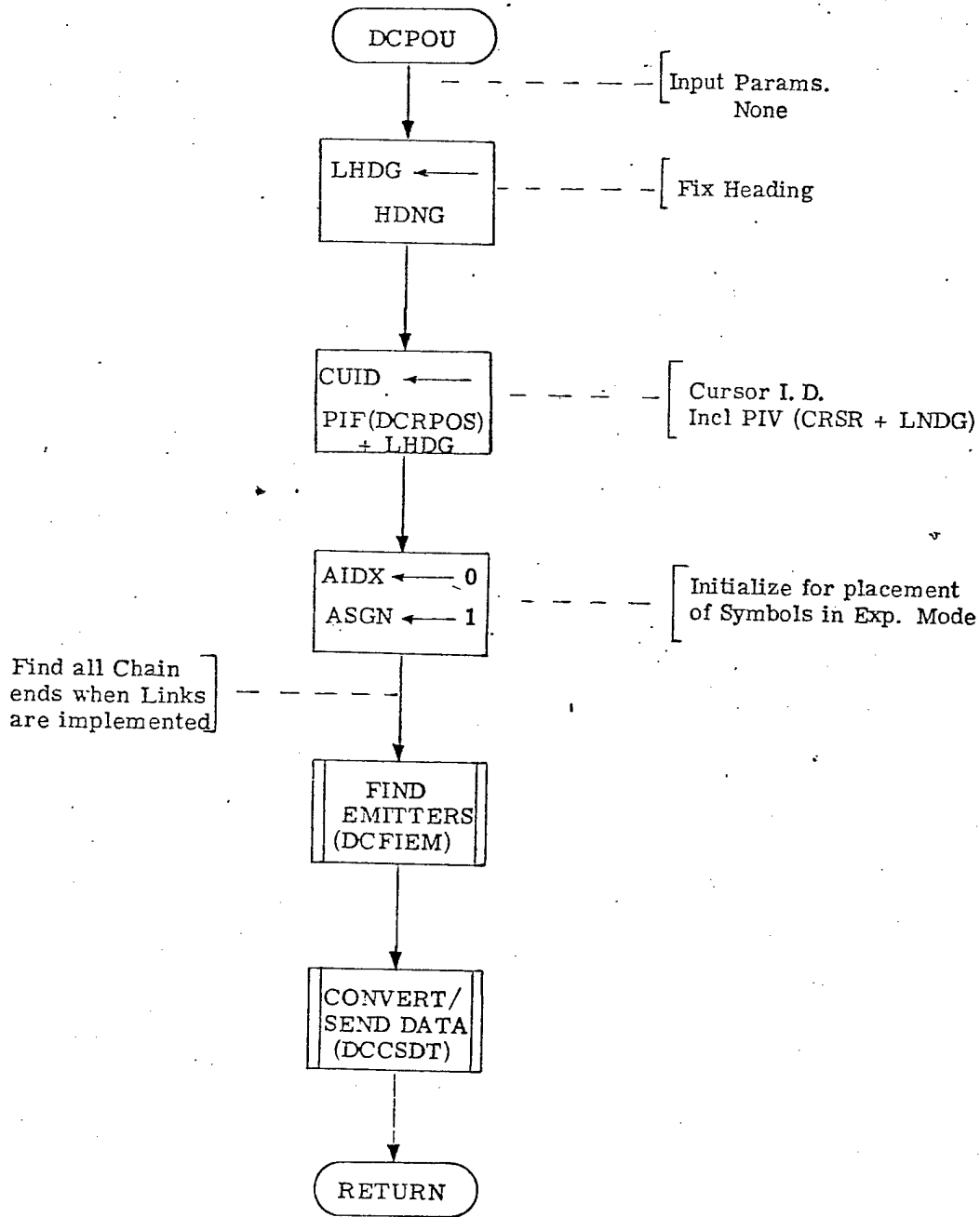

Figure 6. Polar Update (DCPOU)

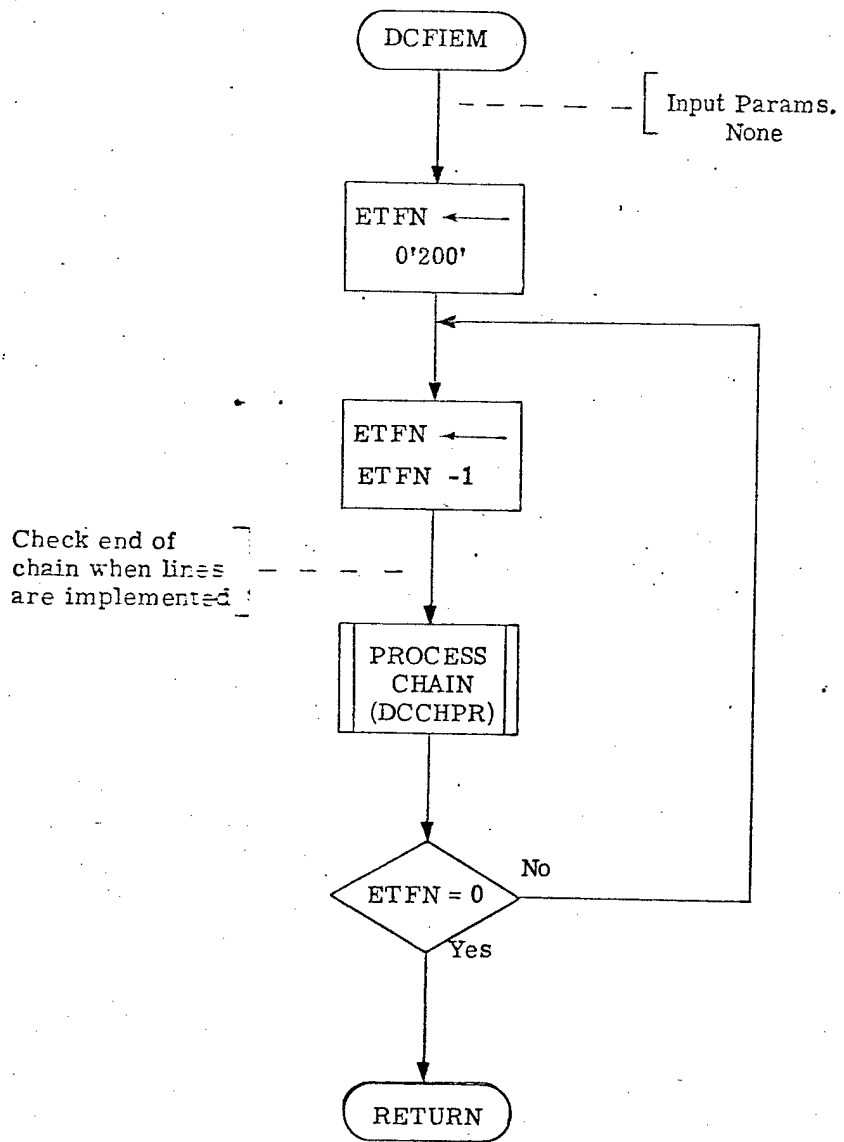

Figure 7. Find Emitters (DCFIEM)

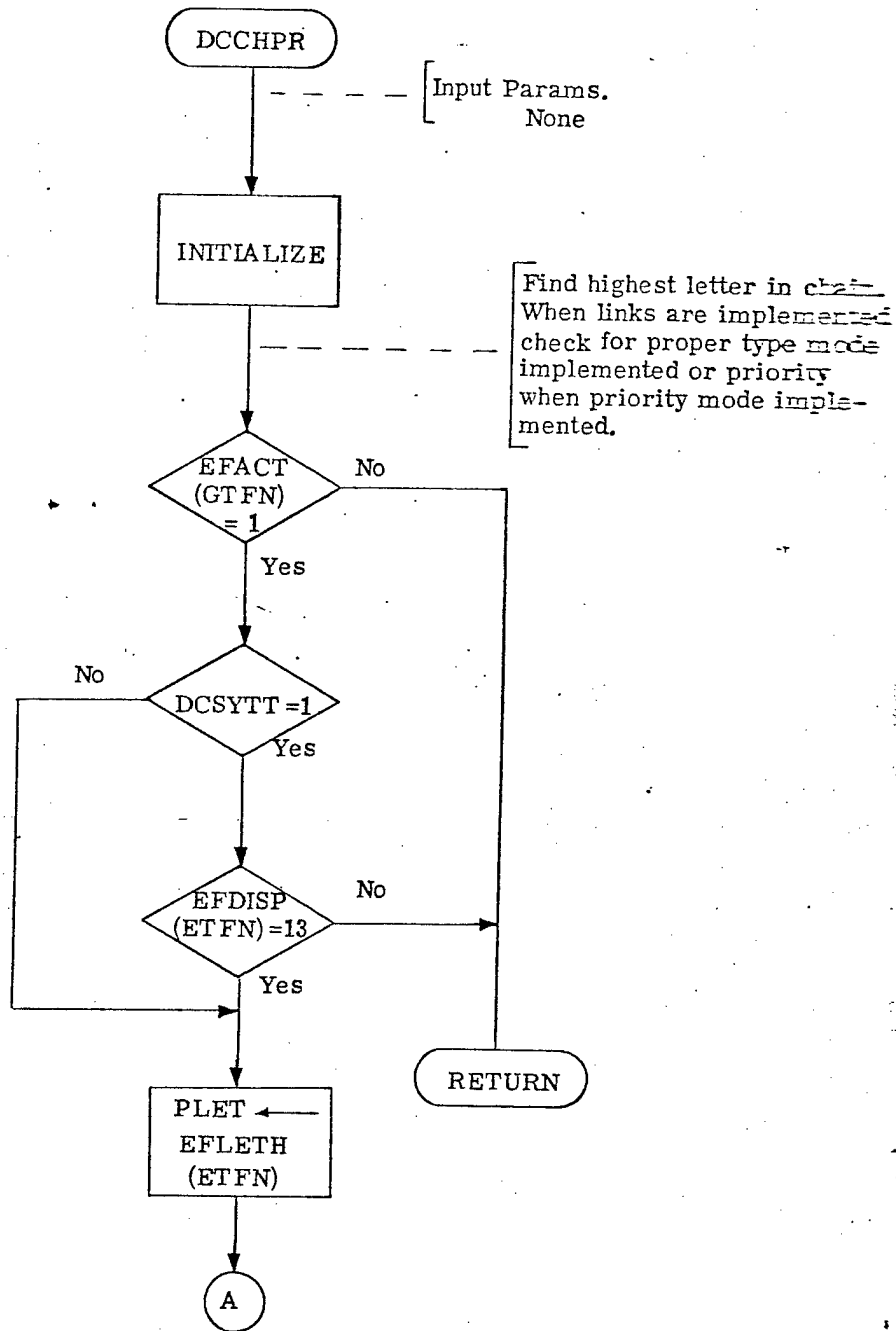

Figure 8. Chain Processing (DCCHPR)

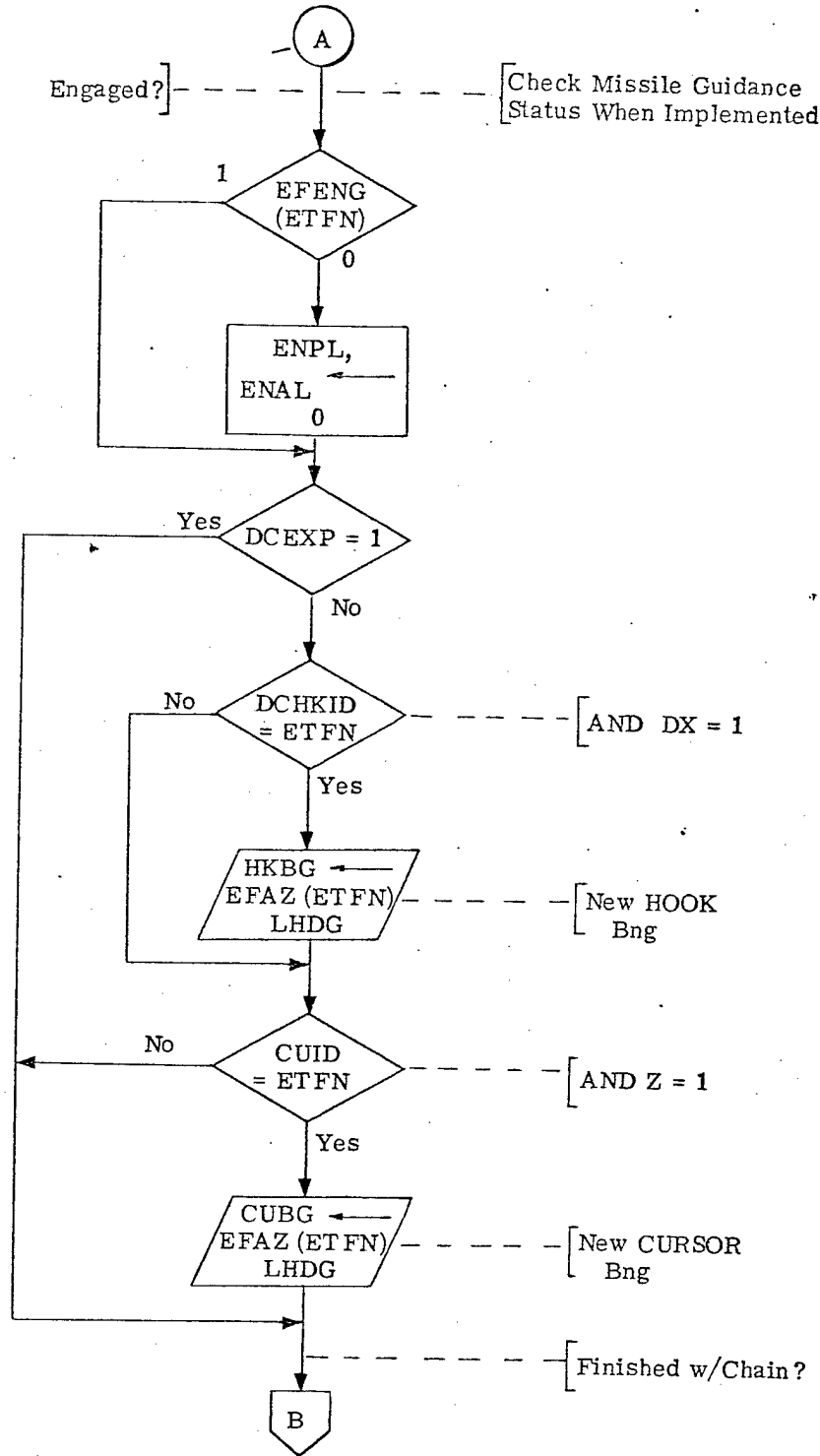

Figure 8. -continued-

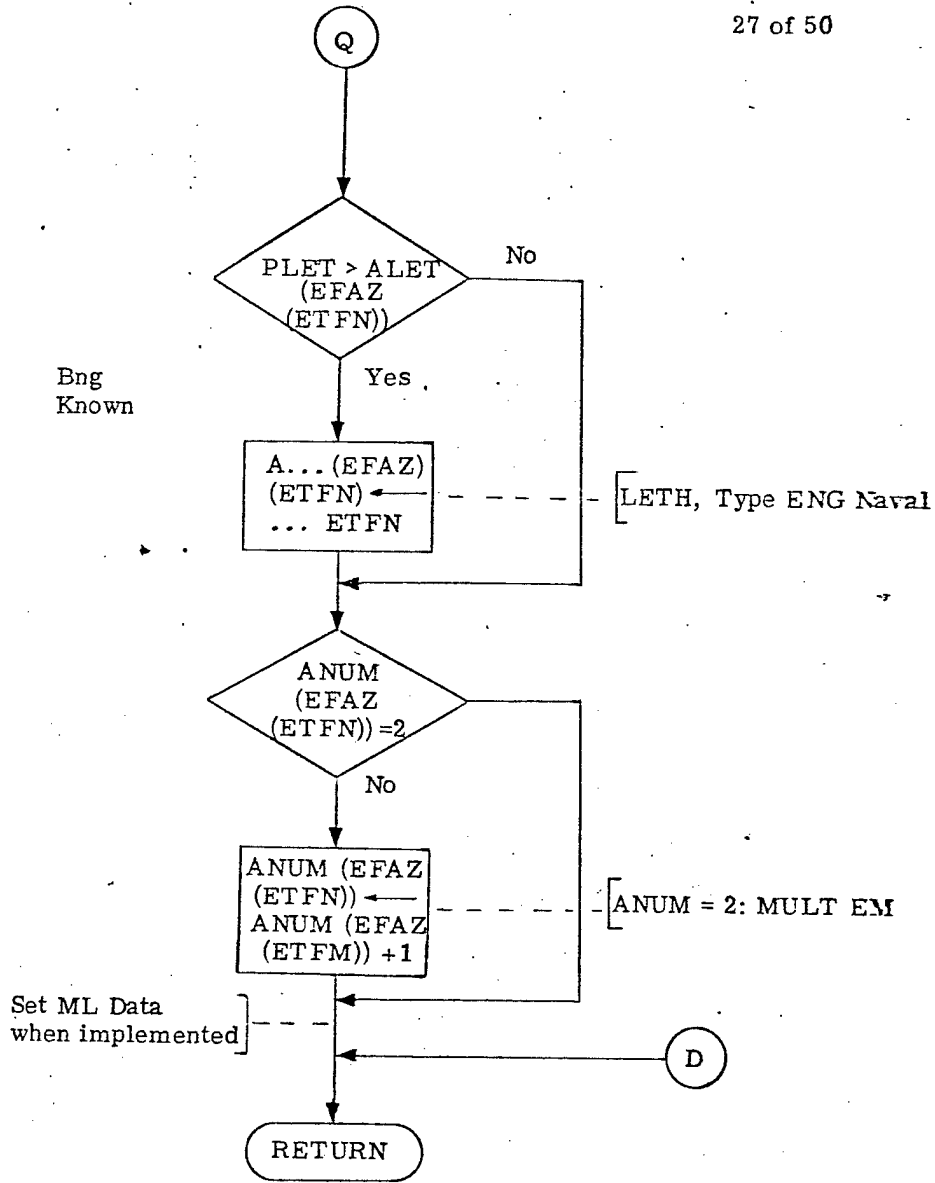

Figure 8. -continued-

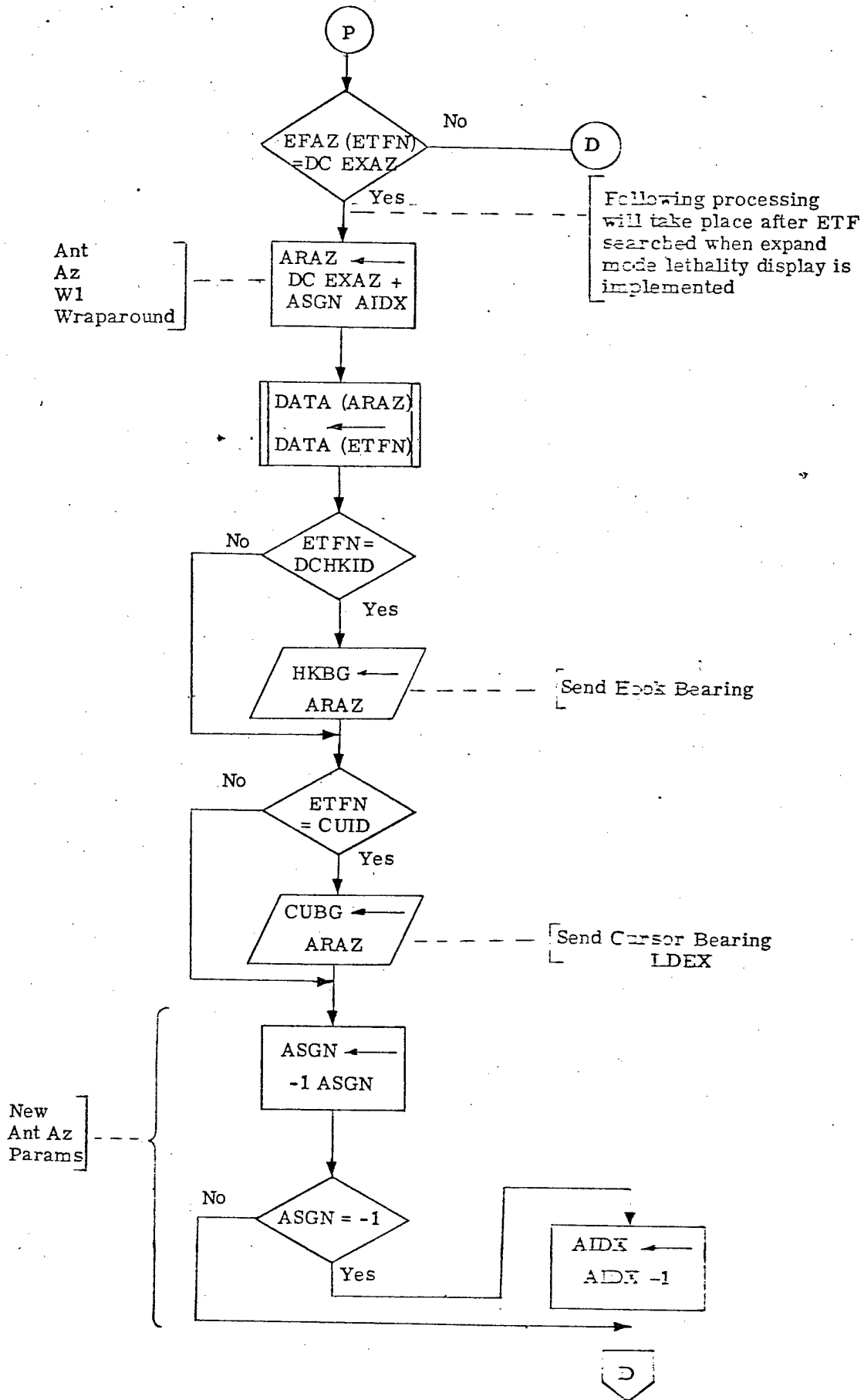

Figure 8. -continued-

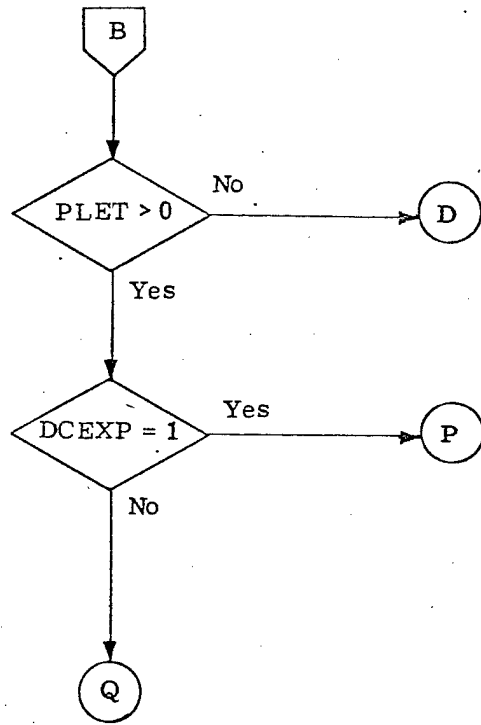

Figure 8. -continued-

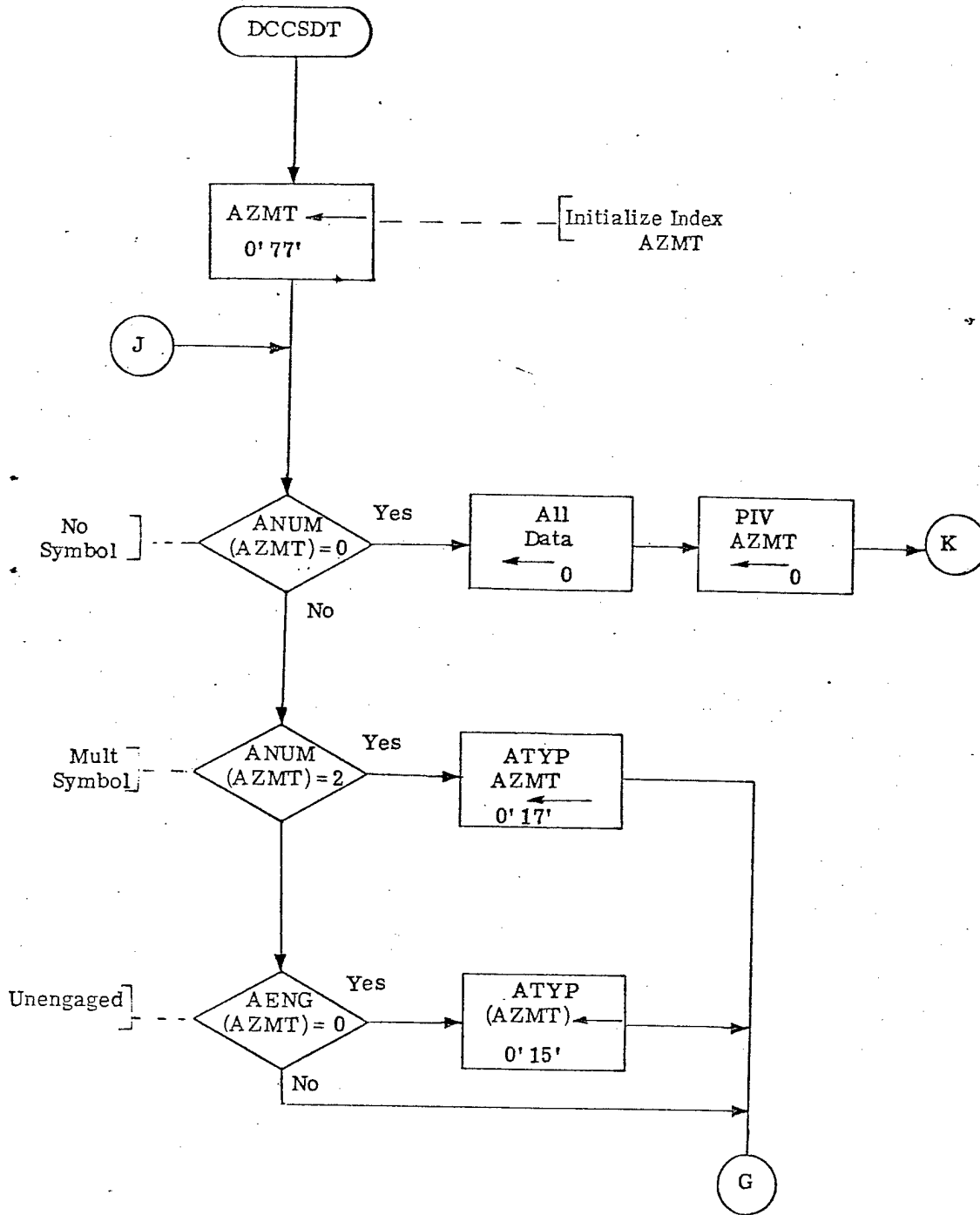

Figure 9. Convert & Send Data (DCCSDT)

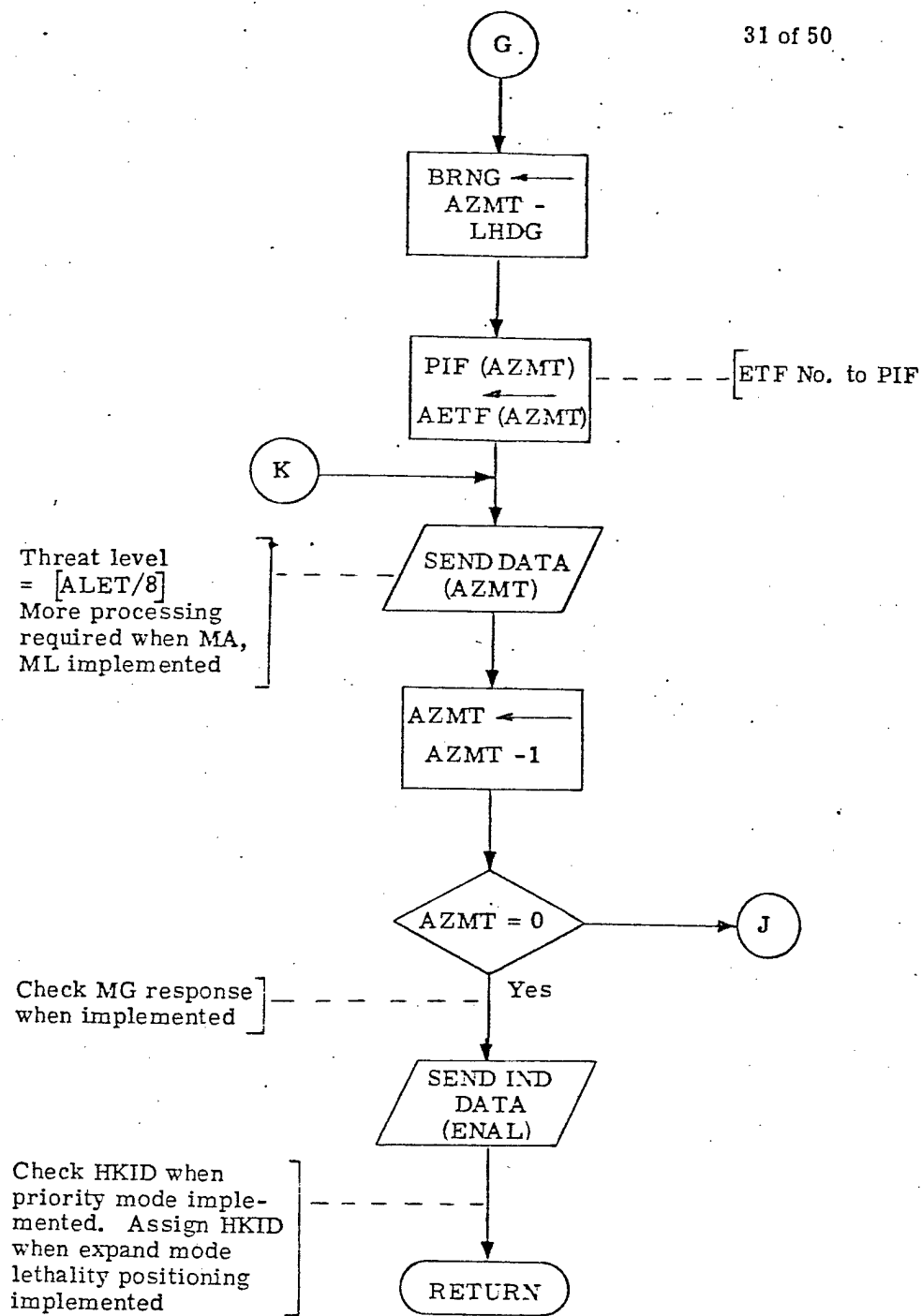

Figure 9. -continued-

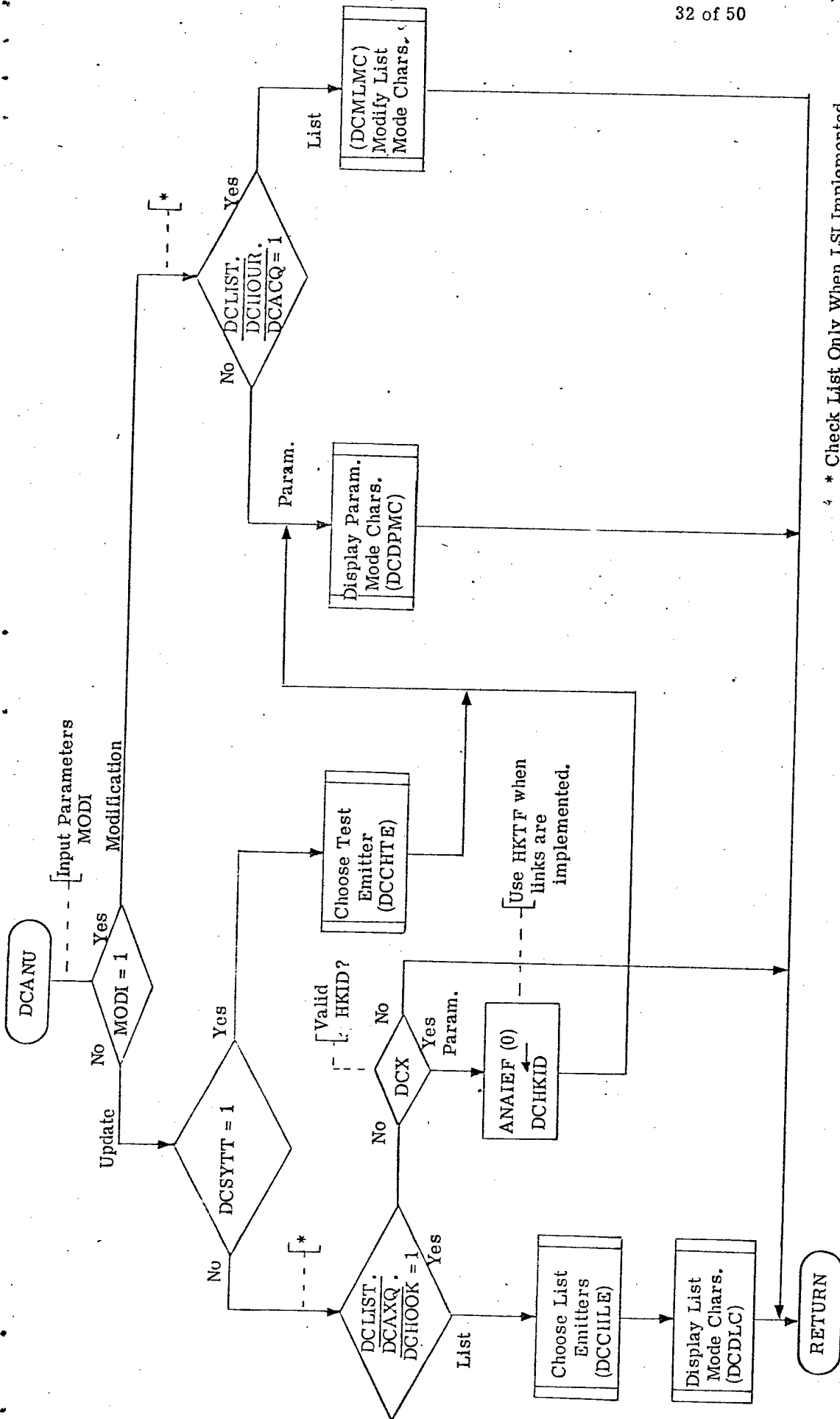

Figure 10. Alpha-Numeric Update (DCANU)

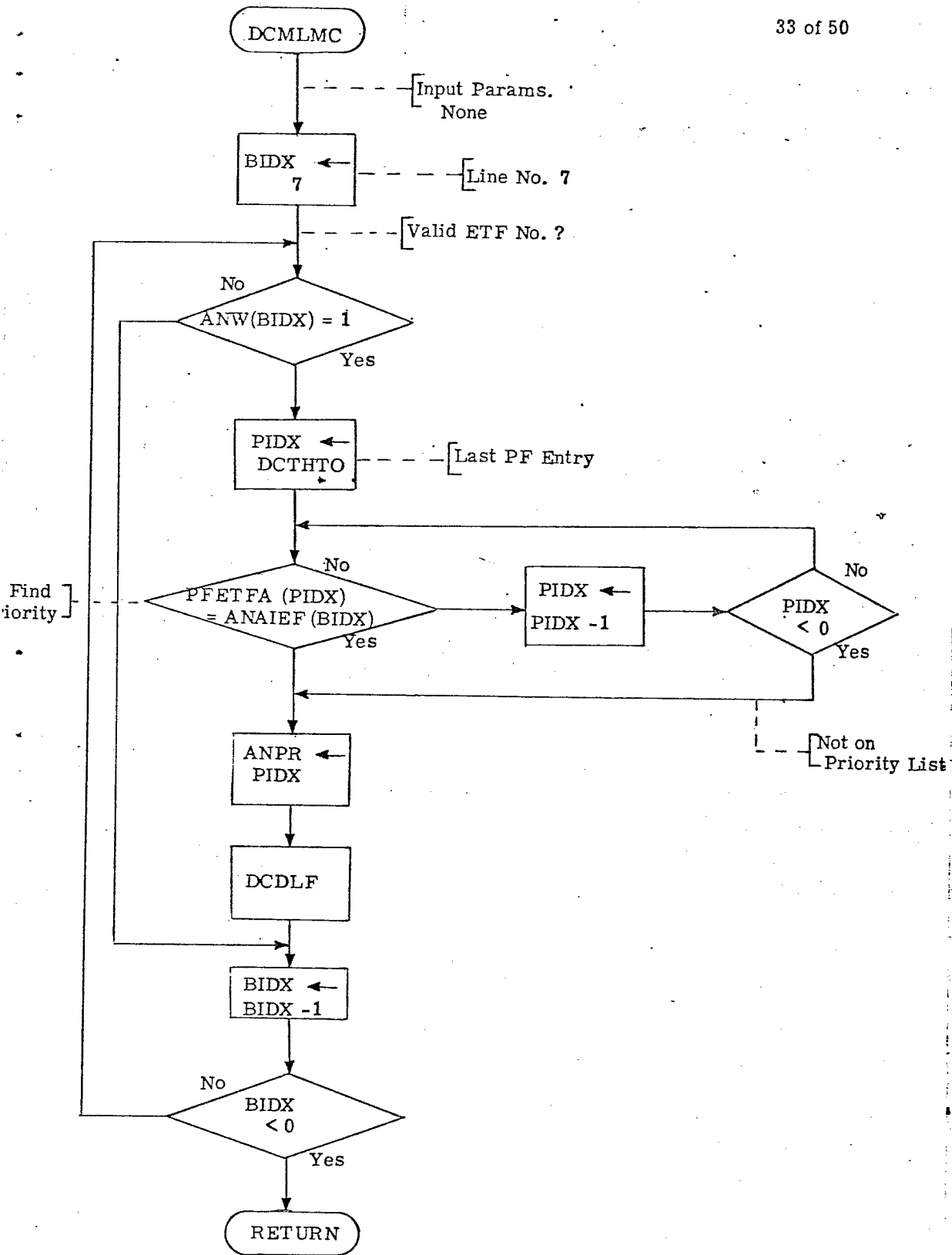

Figure 11. Modify List Mode Characters (DCMLMC)

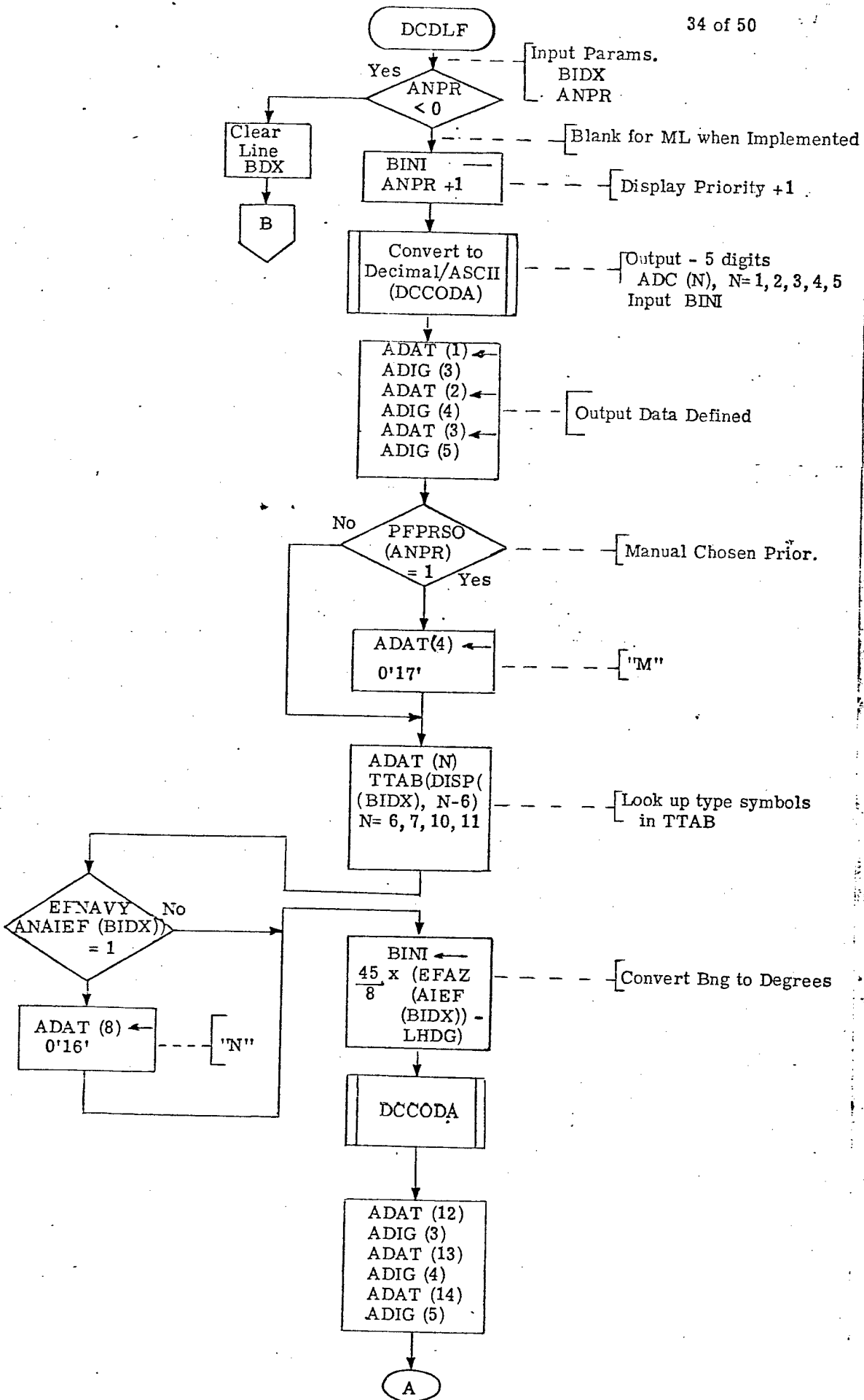

Figure 12. Display List Mode Finish (DCDLF)

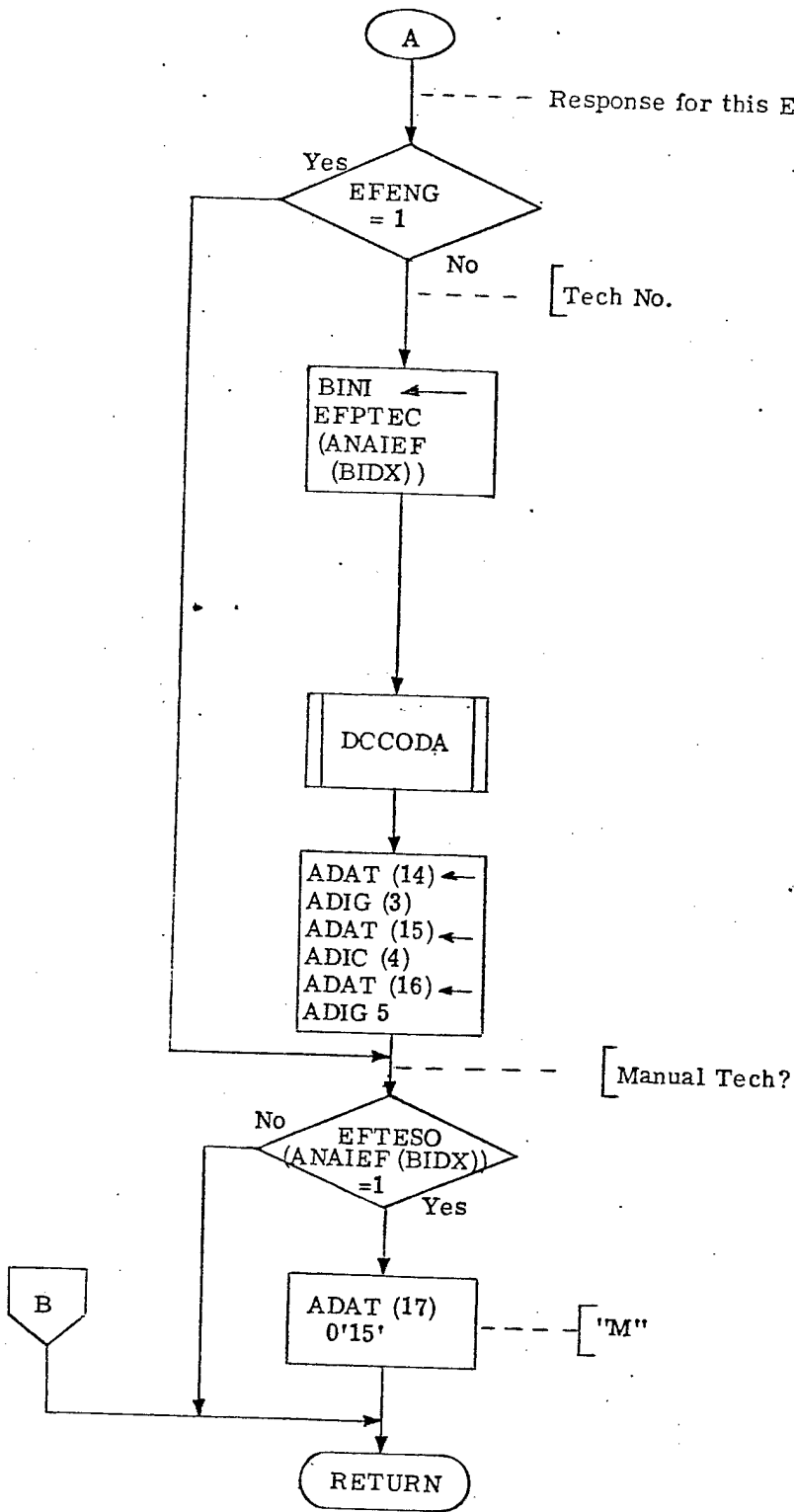

Figure 12. -continued-

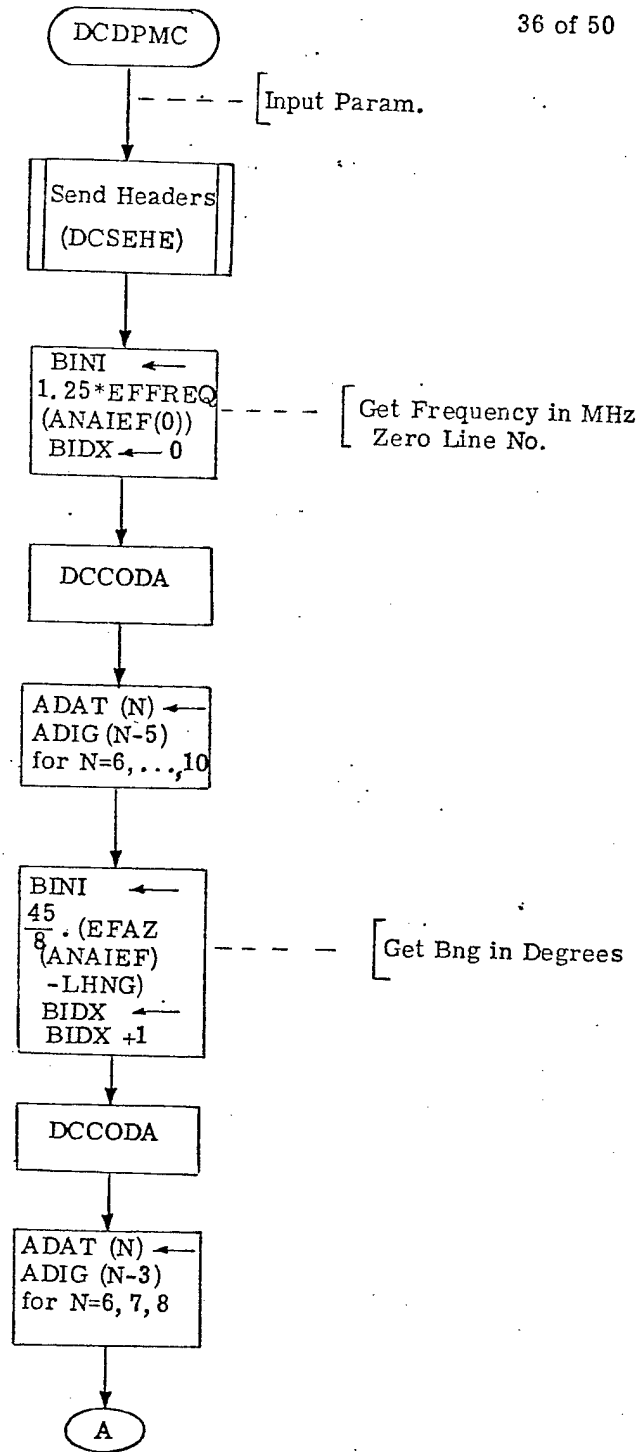

Figure 13. Display Parameter Mode Characters (DCDPMC)

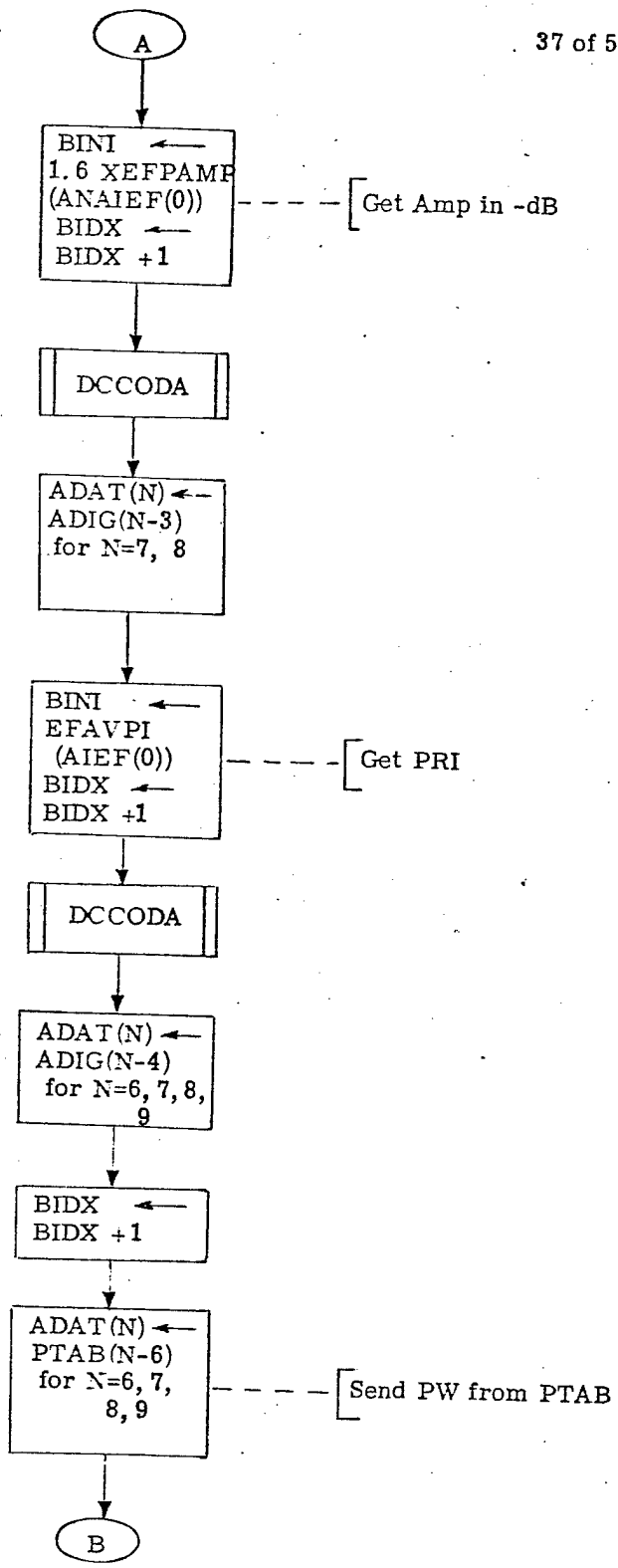

Figure 13. -continued-

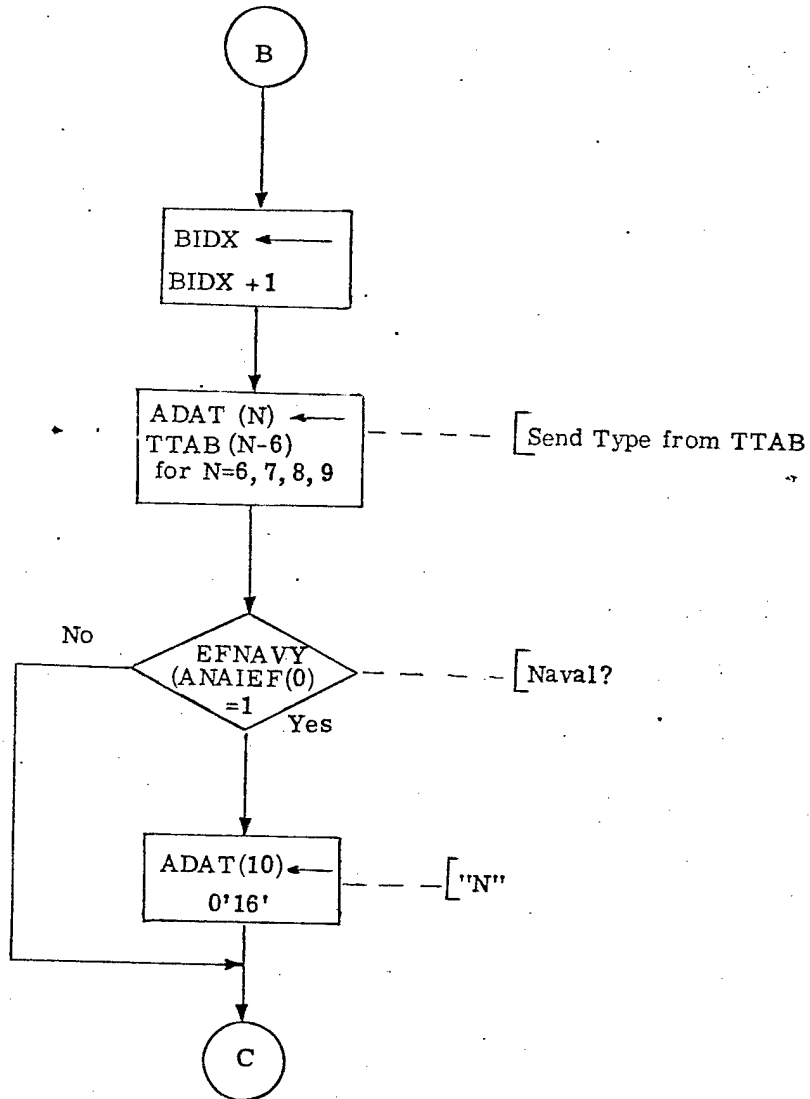

Figure 13. -continued-

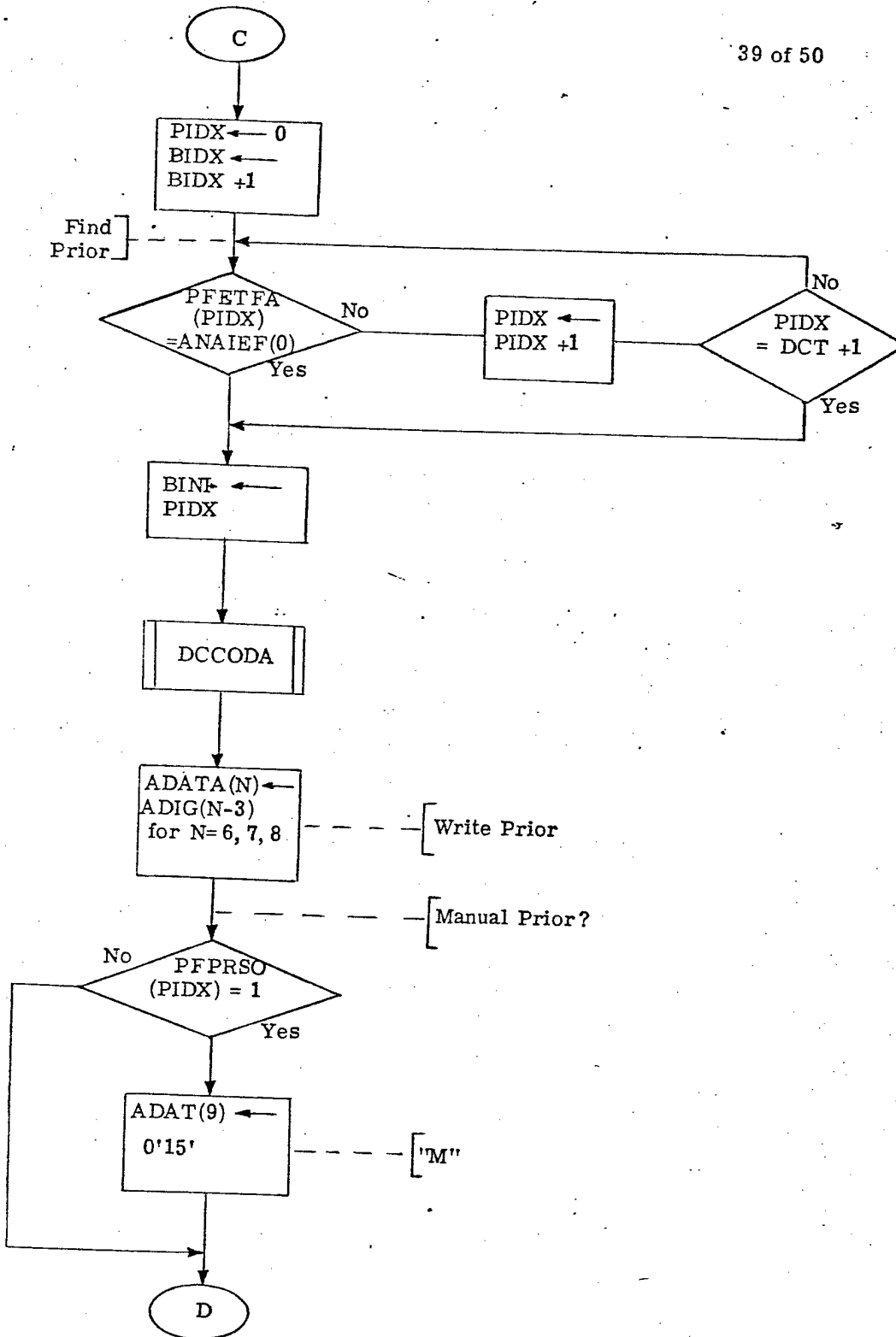

Figure 13. -continued-

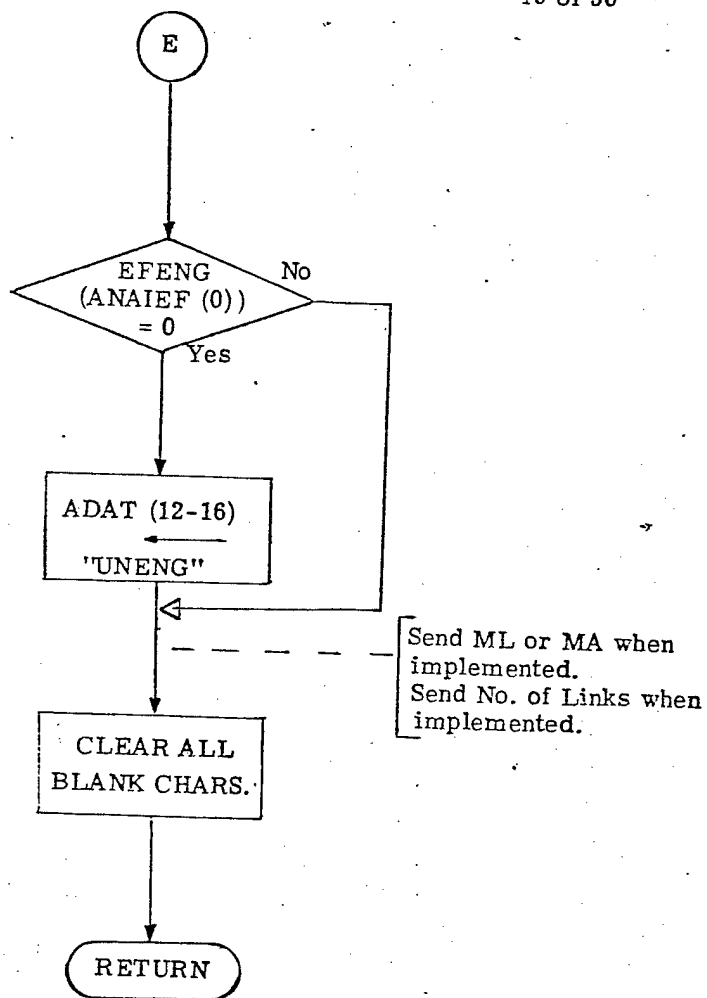

Figure 13. -continued-

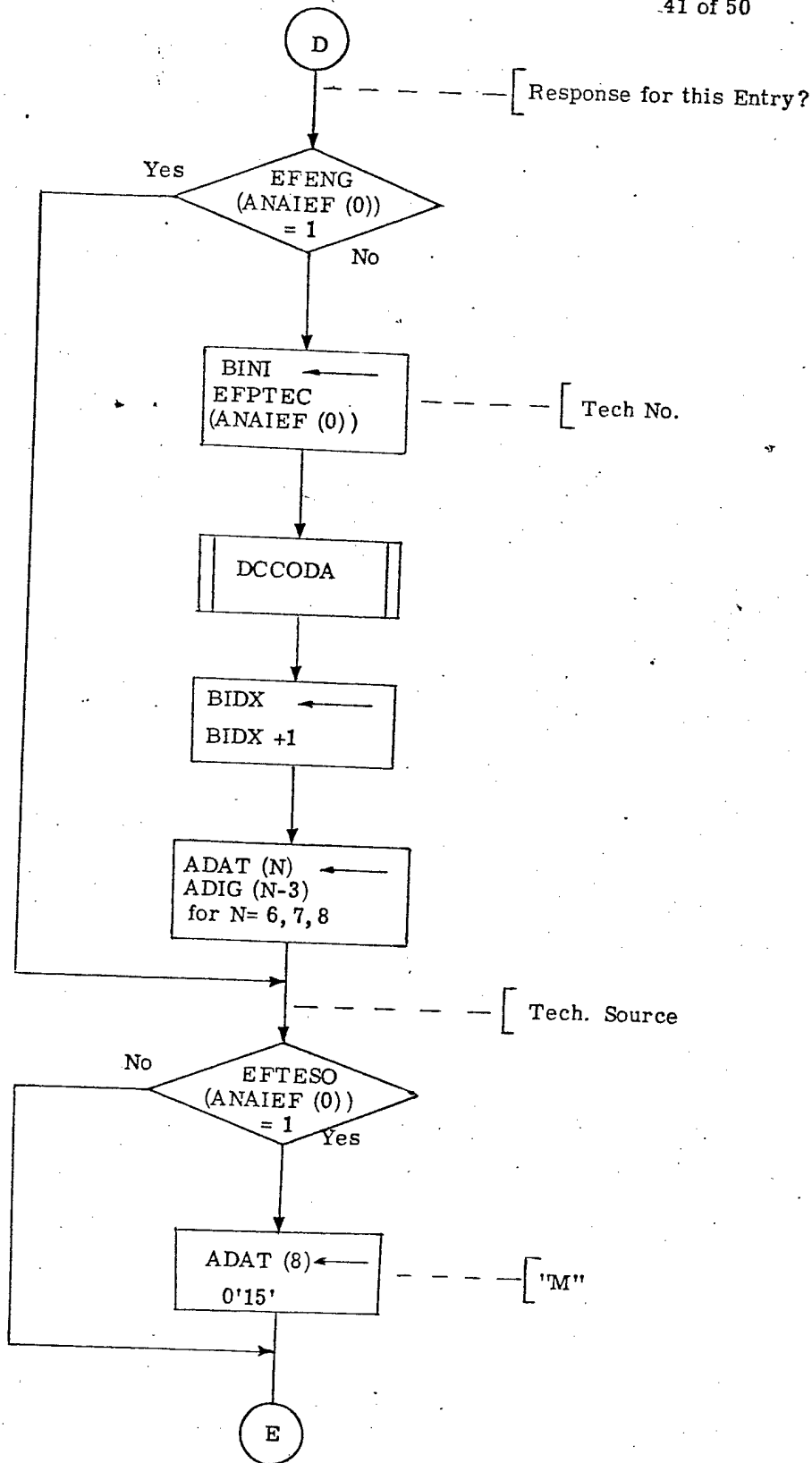

Figure 13. -continued-

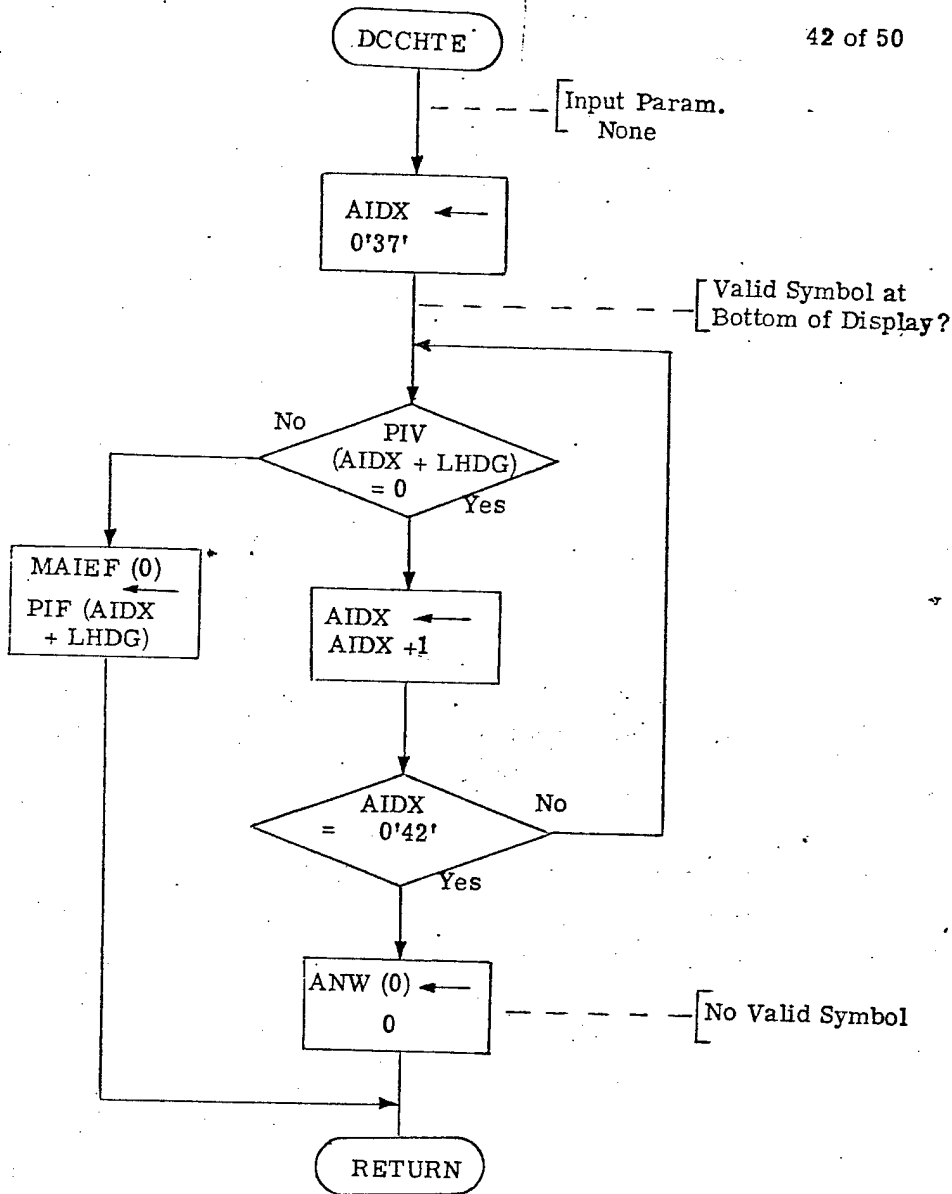

Figure 14. Choose Test Emitter (DCCHTE)

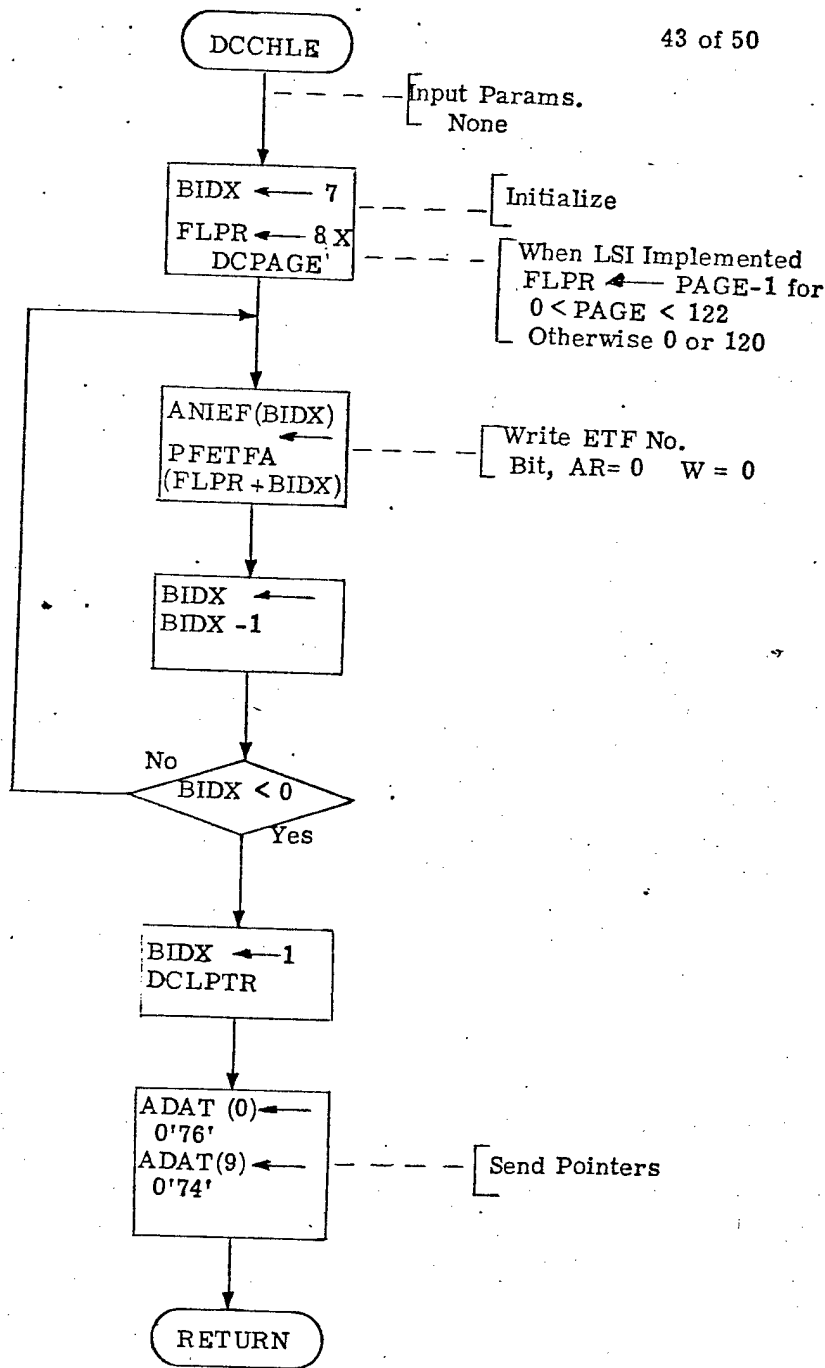

Figure 15. Choose List Emitters (DCCHLE)

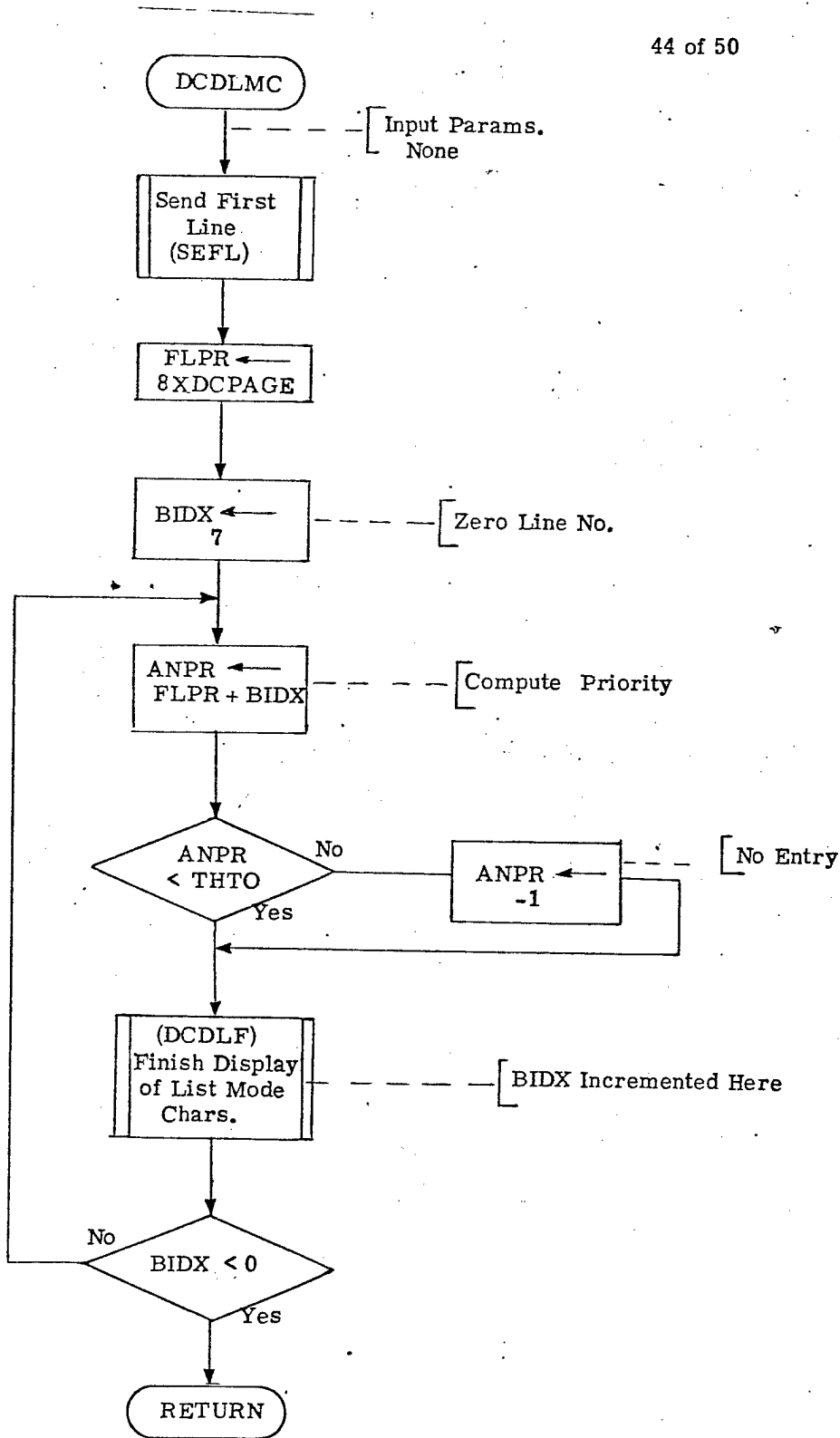

Figure 16. Display List Mode Characters (DCDFMC)

3.3 COMPUTER SUBPROGRAM ENVIRONMENT

3.3.1 Tables

<u>Mnemonic</u>	<u>Name</u>	<u>Purpose</u>	<u>Size</u>	<u>Structure</u>
ADAT	A/N Data	A/N Data	8 x 24	See Doc. 53959-RA-0510
ADIG	A/N Digit	Binary/Decimal Conversion	5 x 6	L. S. B. = ADIG(5), ASCII
PTAB	PW Table	A/N Pulse Width	16 x 4	Decimal ASCII
TTAB	Type Table	A/N Type Symbol	16 x 4	See Doc. 06129-0529

### 3.3.2 Variables

<u>Mnemonic</u>	<u>Name</u>	<u>Purpose</u>	<u>Structure</u>
AENG	Angle Engaged	Polar Update	Eng.
AETF	Angle ETF No.	Polar Update	ETF Address
ALET	Angle Lethality	Polar Update	Lethality
ANAV	Angle Naval	Polar Update	Naval
ANPR	A/N Priority	A/N Update	PF Address
ANUM	Angle Number	Polar Update	LSB=1 Emitter
ARAZ	Artificial Azimuth	Expand Update	Azimuth
BINI	Binary Input	Binary/Dec. Conversion	-
BRNG	Bearing	Display Output	See Doc. 53959-RA-0510
CUID	Cursor I. D.	Polar Update	ETF Address
CUBG	Cursor Bearing	Display Output	See Doc. 53959-RA-0510
FLPR	First List Priority	A/N Update	PF Address
HKBG	Hook Bearing	Display Output	See Doc. 53959-RA-0510
PLET	Platform Lethality	Polar Update	Lethality
TIM1	Timer 1	Timer	LSB = 1 sec.
TIM0	Timer 0	Timer	LSB = .1 sec.

3.3.4 Flags

<u>Mnemonic</u>	<u>Name</u>	<u>Purpose</u>	<u>Structure</u>
ENAL	Engaged - All	Ind. Update	1 = yes
ENPL	Engaged - Platform	Polar Update	1 = yes
MOD I	Modification	A/N Control	1 = yes
RALL	Return All	PF Management	1 = yes
<u>UPDM</u>	Update	Display Control	1 = yes

**RAYTHEON**

RAYTHEON COMPANY  
LEXINGTON, MASS. 02173

CODE IDENT NO.

49956

SPEC NO.

SHEET

48 OF 50

REV

3.3.5

Indexes

<u>Mnemonic</u>	<u>Name</u>	<u>Purpose</u>
AIDX	Angle Index	Expand Symbol Placement
ASGN	Angle Sign	" " "
AZMT	Azimuth	Polar Update
BIDX	Line Index	A/N Update
ETFN	ETF Number	ETF Reference
PIDX	Priority Index	PF Reference

3.3.6 Common Data Base References

<u>Mnemonic</u>	<u>File</u>	<u>Mnemonic</u>	<u>File</u>
ANAIEF	ANIF	DCX	DCSF
ANW	ANIF	DCX	DCSF
DCACQ	DCSF	EFACT	ETF
DCBACK	DCSF	EFAVPI	ETF
DCEXAZ	DCSF	EFAZ	ETF
DCEXP	DCSF	EFDISP	ETF
DCFWD	DCSF	EFENG	ETF
DCHOOK	DCSF	EFFREQ	ETF
DCHKID	DCSF	EFNAVY	ETF
DCKB	DCSF	EFPAMP	ETF
DCLIST	DCSF	EFPTEC	ETF
DCLPTR	DCSF	EFTESO	ETF
DCPAGE	DCSF	EFPW	ETF
DCPE	DCSF	PFETFA	PF
DCRPOS	DCSF	PFPRSO	PF
DCSYTT	DCSF	PFETFA	PF
DCTE	DCSF	PIV	PIP
DCTHTO	DCSF		

3.4 INPUT/OUTPUT FORMATS

Formats for SC Input/Output external hardware is documented in detail in the IEWS ICD. However, the following symbols from the flow charts have different names in the ICD.

<u>Symbol</u>	<u>ICD</u>	<u>Equivalent</u>
ALET	53959 - RA - 0510	Threat Level = [ALET/8]
ACQ	- KH - 0610	A
ANAV	- RA - 0510	N
ATYP	- RA - 0510	Symbol
BACK	- KH - 0610	B
BRNG	- RA - 0510	Sector Address
CRSR	- RA - 0510	Cursor Position
CUBG	- RA - 0510	Reposition Cursor Position
ENAL	- RA - 0510	<u>Uneng. Thrt.</u>
FWD	- KH - 0610	F
HKBG	- RA - 0510	Reposition Hooked Sector
LIST	- KH - 0610	L
STST	- RA - 0510	Sys. Test

Messages from this module to the EXEC are given in the following table.

<u>Message</u>	<u>Data</u>
Priority Override	EFN NPTY
Priority Return	EFN RALL
System Test Start	_____
System Test End	_____
Master Clear	_____

There shall be no messages from the EXEC to this module. Messages to and from peripheral devices are detailed in Document Nos. 53959-RA-0510 and 53959-KH-0610.