

# LOAN DOCUMENT

	DTIC ACCESSION NUMBER		PHOTOGRAPH THIS SHEET	
		LEVEL		INVENTORY
DOCUMENT IDENTIFICATION				
DISTRIBUTION STATEMENT				
<b>ACCESSION FOR</b> NTIS <input type="checkbox"/> GRAM <input checked="" type="checkbox"/> DTIC <input type="checkbox"/> TRAC <input checked="" type="checkbox"/> UNANNOUNCED <input type="checkbox"/> JUSTIFICATION <input type="checkbox"/>		DATE ACCESSIONED		
BY				
DISTRIBUTION/				
AVAILABILITY CODES				
DISTRIBUTION	AVAILABILITY AND/OR SPECIAL	DATE RETURNED		
A-1				
DISTRIBUTION STAMP		REGISTERED OR CERTIFIED NUMBER		
Reproduced From Best Available Copy				
19981223 029		PHOTOGRAPH THIS SHEET AND RETURN TO DTIC-FDAC		
DATE RECEIVED IN DTIC				

H  
A  
N  
D  
L  
E  
  
W  
I  
T  
H  
  
C  
A  
R  
E

4-29-80

REPORT NO. NADC-76070-30



NADC  
Tech. Info.

**AERONAUTICAL ANALYTICAL REWORK PROGRAM**

**INTERIM REPORT**

NO DISTRIBUTION  
STATEMENT

**EVALUATION OF DRAFT HANDBOOK FOR  
SEALS IN NAVAL AIRCRAFT**

OCTOBER 1976

CONTRACT N00209-74-M-2510

*[Large handwritten signature]*

APP SLP PROJECT OFFICE

NAVAL AIR DEVELOPMENT CENTER, WARMINSTER, PA 18974

ENCL (1)

Aeronautical Analytical Rework Program

Evaluation of Draft Handbook  
for Seals in Naval Aircraft

Analytical Rework/Service Life Project Office  
Air Vehicle Technology Department  
Naval Air Development Center  
Warminster, Pa. 18974

September 1976

Aeronautical Analytical Rework Program

Evaluation of Draft Handbook  
for Seals in Naval Aircraft

By

J. M. McGrew

Prepared for

Analytical Rework/Service Life Project Office  
Air Vehicle Technology Department  
Naval Air Development Center  
Warminster, Pa. 18974

Under

Contract N62269-76-M-2530

September 1976

SHAKER RESEARCH CORPORATION  
Northway 10 Executive Park  
Ballston Lake, N.Y. 12019

TABLE OF CONTENTS

	<u>Page</u>
ABSTRACT _____	iii
FOREWORD _____	iv
LIST OF FIGURES _____	v
LIST OF TABLES _____	v
1.0 INTRODUCTION _____	1
2.0 SOLICITATION OF COMMENTS _____	2
3.0 EVALUATION OF COMMENTS _____	6
3.1 Usefulness of Handbook _____	6
3.2 Sufficiency of Detail _____	6
3.3 Format _____	6
3.4 Suitability as a Naval Technical Manual _____	6
3.5 Currentness of Data _____	7
3.6 Recommended Changes _____	7
3.7 Additional Information _____	7
4.0 CONCLUSIONS _____	9
5.0 RECOMMENDATIONS _____	10
APPENDIX A - List of Survey Organizations _____	11
APPENDIX B - User Evaluation Forms _____	19
APPENDIX C - Recommended Changes _____	36

ABSTRACT

Under Contract N62269-74-C-0379, Shaker Research Corporation has prepared a Handbook for Seals in Naval Aircraft. The manual has been distributed in draft form. The objective of the work described here was to solicit comments and suggestions on the draft manual from recipients of the distribution list, and to correlate and evaluate all such comments and suggestions. The report provides a summary of the recommendations, along with supporting rationale, as to what items should be included in the final manual to be issued.

FOREWORD

The work described in this report was performed under the sponsorship of the Analytical Rework Program, Naval Air Systems Command (AIR-4111A6) to solicit comments and suggestions on a draft seal handbook aimed at establishing uniform practice in the Navy for selection, application, and maintenance of seals. The work was monitored by D. V. Minuti of the Naval Air Development Center, Warminster, Pennsylvania.

LIST OF FIGURES

	<u>Page</u>
1 USER EVALUATION FORM _____	3

LIST OF TABLES

	<u>Page</u>
1 NAVY SEAL HANDBOOK SURVEY _____	4
2 RESPONSE TO QUESTIONNAIRE _____	5

## 1.0 INTRODUCTION

The Naval Air Development Center is reviewing, as part of the Analytical Rework Program, seal maintenance problems on Naval aircraft. Under Contract N62269-74-C-0379, problem areas were identified where improvements were needed in operation and/or maintenance. In cases where the state of the art was not satisfying the operational requirements, additional R & D efforts were proposed for developing new seal materials and/or designs. The survey indicated that the following seal types:

- o Face seals
- o Circumferential seals
- o Lip seals
- o O-rings
- o Form-in-place seals

are current maintenance problems on Naval aircraft.

A draft manual was prepared which addressed itself to establishing uniform practice in the Navy for selection, application, and maintenance of these types of seals.

The objective of the work described here was to solicit comments and suggestions on the draft manual from recipients of the distribution list, and to correlate and evaluate all such comments and suggestions.

This report provides a summary of the recommendations, along with supporting rationale, as to what items should be included in the final manual to be issued.

## 2.0 SOLICITATION OF COMMENTS

The draft manual was presented at the Fourth Annual Meeting of the Analytical Rework Program held at the Naval Air Development Center. Many valuable comments and recommendations on the manual were made at that time.

Subsequent to the meeting, comments were solicited from the organizations and individuals listed in Appendix A.

Figure 1 illustrates the User Evaluation Form distributed with the letter requesting comments. In addition, telephone contacts and personal visits were made to selected individuals for greater in depth evaluation.

In all forty-six inquiries were sent out and the sixteen responses listed in Appendix B and Table 1 were received. This is a thirty-five percent return which is fairly good for this type of survey.

Most responses were limited to filling out the Evaluation Form, but several of the respondents provided extensive written evaluations which will be discussed later.

The organizations surveyed fell into three general classifications as shown in Table 2.

- o Users
- o Manufacturers
- o Research and Standard Organizations

The thirty-eight users surveyed were military organizations, primarily Navy installations.

Five manufacturers were also contacted representing manufacturers of all of the seal types covered in the manual except form-in-place seals.

FIGURE 1

USER EVALUATION FORM

DRAFT HANDBOOK FOR SEALS IN NAVAL AIRCRAFT

1. Did you find the Handbook useful? Yes\_\_\_ No\_\_\_
2. Does it contain sufficient detail? Yes\_\_\_ No\_\_\_
3. Did the format make the Handbook easy to use? Yes\_\_\_ No\_\_\_
4. Should the Handbook be made into a Naval Technical Manual? Yes\_\_\_ No\_\_\_
5. Do you feel that the Handbook data is current state-of-the-art information? Yes\_\_\_ No\_\_\_
6. It is suggested that the Handbook could be improved by making the following changes:

7. Reasons for suggested changes are:

8. It is further suggested that the Handbook could be made more useful to users by adding material on the following (indicate sources of required information is known):

\_\_\_\_\_  
(signature) (date)

\_\_\_\_\_  
(title, organization)

-----  
(return address)

TABLE 1

NAVY SEAL HANDBOOK SURVEY

ORGANIZATION NUMBER	QUESTION #1		QUESTION #2		QUESTION #3		QUESTION #4		QUESTION #5	
	Yes	No	Yes	No	Yes	No	Yes	No	Yes	No
1	X		X		X		X		X	
2	X		X		X		X		X	
3	X		X		X			X	X	
4	X		X		X		X		X	
5	X		X		X		X			X
6	X		X		X		X		X	
7	-	-	-	-	-	-		X	X	
8	X		X		X		X		X	
9	X		X		X		X		X	
10	X		X		X		X		X	
11	Too Long Winded		Too Much		X		X (For Info)			X
12	X		X		X		X		X	
13	X		X		X		X		X	
14	X		X		X		-		X	
15		X	X		X		X		X	
16	X		X		X		-		X	

Lastly, one research organization, NASA Lewis, and the chairmen of the seals committees of the American Society of Mechanical Engineers and the American Society of Lubrication Engineers were also included in the survey. The comments of the latter two individuals are particularly important since they represent the two organizations in this country which are working towards standardization of seal usage.

TABLE 2

RESPONSE TO QUESTIONNAIRE

	<u>Number Surveyed</u>	<u>Number of Completed Responses</u>	<u>Percent Response</u>
Users	38	12	32%
Manufacturers	5	2	40%
Research and Standard Organizations	3	2	66%
TOTAL.....	<u>46</u>	<u>16</u>	<u>35%</u>

### 3.0 EVALUATION OF COMMENTS

The results of the solicitation of comments is discussed in the following according to the format of the User Evaluation Form.

#### 3.1 Usefulness of Handbook

The overwhelming response to this question was positive (13 for, 1 against, and 2 abstentions).

One reviewer commented that he thought the document was "too wordy". Perhaps further editing would remove this one unfavorable reaction.

#### 3.2 Sufficiency of Detail

Except for one reviewer, all of the respondees felt that the draft handbook contained sufficient detail. The same reviewer who felt the draft handbook was "too wordy" also felt that there was "too much" detail. Based upon the overall responses, it appears that the handbook contains the correct amount of detail.

#### 3.3 Format

The consensus among the respondees was that the presentation format made the handbook easy to use. Only one reviewer felt otherwise.

#### 3.4 Suitability as a Naval Technical Manual

This was the one question which evoked the greatest differences of opinion of the sixteen (16) responses; four (4) elected to recommend against the adoption of the draft handbook as a seal manual and two (2) did not answer the question. Nonetheless, sixty-three percent felt it should be made into a Navy Technical Manual.

### 3.5 Currentness of Data

Two (2) out of the sixteen (16) respondees felt that the data was not current state-of-the-art. Both of these responses were from users. All of the manufacturers and standard organizations felt that it was state-of-the-art information.

### 3.6 Recommended Changes

The number of recommended changes was not large. Most of these were typographical in nature and they have been summarized in Appendix C along with the reasons for the suggested changes.

### 3.7 Additional Information

Several of the reviewers felt that the handbook would be strengthened by the inclusion of additional information.

#### 3.7.1 Fundamentals of Seal Theory

The handbook assumes that the reader was already familiar with seal types and theory. One reviewer felt that a section should be added dealing with the fundamentals of seal theory, both for static and dynamic seals.

#### 3.7.2 T-Seals

Two of the reviewers recommended that a section on T-seals be added.

#### 3.7.3 Two Stage Unvented Rod Seals

It was also suggested by one reviewer that information on two stage, unvented rod seals be added to the manual.

#### 3.7.4 Packaging Instructions

Most seals and O-rings are identified with a packaging code, which is defined by Military Standard MIL-STD-726 for the specific type of preservation and packaging required by Military Specification MIL-P-116.

These packaging codes are found in the Aviation Supply Office Milstrip Ordering Sections C0030 and P2310. Therefore, in the interest of completeness, one reviewer recommended that the packaging section of each chapter should indicate that specific packaging instructions are available for all seals and O-rings.

#### 4.0 CONCLUSIONS

The report "Draft Handbook for Seals in Naval Aircraft" has been reviewed by a selected group of users, manufacturers, and research/standard organizations. Analysis of their responses to a survey questionnaire and evaluation of their comments has resulted in the following conclusions:

1. The report is a useful document and should find particular application as a reference for Naval Aircraft Rework Facility Engineering staffs and technical writers for maintenance instructions.
2. The degree of detail is sufficient for its intended application.
3. The format is easy to use and should be retained.
4. The handbook should be made into a Naval Technical Manual.
5. The data contained in the manual is current state-of-the-art information.
6. The draft handbook contains several typographical errors. The companion document "Review of Seal Maintenance Problems on Naval Aircraft" contains an error of fact. These are outlined in Appendix C.
7. The handbook's value would be enhanced by adding information on
  - o Seal Theory
  - o T-Seals
  - o Packaging Data
  - o Face Seal Rework

## 5.0 RECOMMENDATIONS

Based on the evaluation of the response to the draft handbook User Evaluation Form and comments of the various reviewers, the following is recommended:

1. The recommended changes (Appendix C) should be incorporated in the draft manual.
2. The manual should be expanded to include:
  - o Section on Theory of Seals
  - o Section on T-Seals
  - o Additional Information on Rework of Face Seals
  - o Additional Packaging Instructions
3. After incorporation of the recommended changes and inclusion of the additional sections, the draft handbook should be issued as a Navy Technical Manual.

APPENDIX A

List of Survey Organizations

Users

Commander  
Naval Air Systems Command (AIR-411B4)  
Washington, D.C. 20361

Commander  
Naval Air Systems Command (AIR-320)  
Washington, D.C. 20361

Commander  
Naval Air Systems Command (AIR-520)  
Washington, D.C. 20361

Commander  
Naval Air Systems Command (AIR-52022)  
Washington, D.C. 20361

Commander  
Naval Air Systems Command (AIR-5203)  
Washington, D.C. 20361

Commander  
Naval Air Systems Command (AIR-530)  
Washington, D.C. 20361

Commander  
Naval Air Systems Command (AIR-53442D)  
Washington, D.C. 20361

Chief of Naval Material  
Navy Department (MAT 00R1)  
Washington, D.C. 20361

Commander  
Naval Air Systems Command Rep., Atlantic (33)  
Naval Air Station  
Norfolk, Virginia 23511

Commander  
Naval Air Systems Command Rep., Pacific (332)  
Naval Air Station, North Island  
San Diego, California 92135

Commander  
Naval Air Force (528)  
U.S. Atlantic Fleet  
Naval Air Station  
Norfolk, Virginia 23511

Commander  
Naval Air Force (74)  
U.S. Pacific Fleet  
Naval Air Station, North Island  
San Diego, California 92135

Commanding Officer  
Naval Air Rework Facility (300)  
Marine Corps Air Station  
Cherry Point, N. Carolina 28533

Commanding Officer  
Naval Air Rework Facility (340)  
Marine Corps Air Station  
Cherry Point, N. Carolina 28533

Commanding Officer  
Naval Air Rework Facility (340)  
Naval Air Station  
Norfolk, Virginia 23511

Commanding Officer  
Naval Air Rework Facility (300)  
Naval Air Station  
Norfolk, Virginia 23511

Commanding Officer  
Naval Air Rework Facility (300)  
Naval Air Station  
Jacksonville, Florida 32212

Appendix A (continued)

Commanding Officer  
Naval Air Rework Facility (340)  
Naval Air Station  
Jacksonville, Florida 32212

Commanding Officer  
Naval Air Rework Facility (300)  
Naval Air Station  
Pensacola, Florida 32508

Commanding Officer  
Naval Air Rework Facility (340)  
Naval Air Station  
Pensacola, Florida 32508

Commanding Officer  
Naval Air Rework Facility (300)  
Naval Air Station  
Alameda, California 94501

Commanding Officer  
Naval Air Rework Facility (340)  
Naval Air Station  
Alameda, California 94501

Commanding Officer  
Naval Air Rework Facility (300)  
Naval Air Station, North Island  
San Diego, California 92135

Commanding Officer  
Naval Air Rework Facility (340)  
Naval Air Station, North Island  
San Diego, California 92135

Chief of Naval Reserve  
Naval Air Station  
New Orleans, Louisiana 70146

Chief of Naval Air Training  
Naval Air Station  
Corpus Christi, Texas 78419

Appendix A (continued)

Commandant of the Marine Corps  
Navy Department (AA J5)  
Washington, D.C. 20380

Director  
Naval Research Laboratory (6170)  
Washington, D.C. 20390

Commanding Officer  
Naval Air Engineering Center (ESSD) (ES-1)  
Lakehurst, New Jersey 08733

Commanding Officer  
Naval Air Propulsion Test Center  
Trenton, New Jersey 08628

Commander  
United States Air Force  
San Antonio Air Materiel Area (MMEW)  
Kelly Air Force Base, Texas 78241

Commander  
United States Air Force  
Air Force Materials Laboratory (AFML/LTM)  
Wright-Patterson Air Force Base, Ohio 45433

Commander  
United States Air Force  
Warner-Robins Air Materiel Area (MME)  
Robins Air Force Base, Georgia 31094

Commanding Officer  
U.S. Army Aviation Systems Command  
Corpus Christi Army Depot (CCAD) (SAVAE-GG)  
Corpus Christi, Texas 78419

Director  
U.S. Army Materials & Mechanics Research Center  
Watertown, Massachusetts 02172  
Attention: Mr. Robert Singler

Commanding General  
U.S. Army Armament Command  
Rock Island, Illinois 61202

Mr. William L. Andre  
U.S. Army Air Mobility Research & Development Lab  
AMES Research Center  
Moffett Field, California 94035

Chief Petty Officer in Charge  
Service School Command Glakes  
Detachment Chanute, TWSMN  
Chanute Air Force Base, Illinois 61868

Manufacturers

Gould, Inc.  
Engine Parts Division  
17000 St. Clair Avenue  
Cleveland, Ohio

Crane Packing Company  
6400 Oakton Street  
Morton Grove, Illinois

Parker Seal Company  
10567 Jefferson Boulevard  
Culver City, California 90230

Rexnord  
Seal Division  
634 Glenn Avenue  
Wheeling, Illinois 60090

Sealol, Inc.  
P. O. Box 2158  
Providence, Rhode Island

Research and Standard Organizations

Mr. James D. McHugh  
Chairman, ASME Seals Committee  
Manager, Bearings, Seals & Rotor Systems  
General Electric Company  
Schenectady, New York 12345

Mr. H. B. Hummer  
Chairman, ASLE Seal Committee  
Director of Engineering  
Durametallic Corporation  
2104 Factory Street  
Kalamazoo, Michigan 49001

National Aeronautics and Space Administration  
Lewis Research Center  
Cleveland, Ohio 44135

APPENDIX B

User Evaluation Forms

DRAFT HANDBOOK FOR SEALS IN NAVAL AIRCRAFT

1. Did you find the Handbook useful? Yes X No \_\_\_
2. Does it contain sufficient detail? Yes X No \_\_\_
3. Did the format make the Handbook easy to use? Yes X No \_\_\_
4. Should the Handbook be made into a Naval Technical Manual? Yes X No \_\_\_
5. Do you feel that the Handbook data is current state-of-the-art information? Yes X No \_\_\_
6. It is suggested that the handbook could be improved by making the following changes:

7. Reasons for suggested changes are:

8. It is further suggested that the handbook could be made more useful to users by adding material on the following (indicate sources of required information if known):

A section (or sections) dealing with the fundamentals of seal theory, both for static and dynamic seals, would be useful. This would not be tied to specific seal types, but would be more general; e.g., fluid-flow laws in different regimes - molecular, laminar, turbulent, choked, etc. A section on wear of different materials, or wear fundamentals, would also be worth including.

\_\_\_\_\_  
 (1)  
 (signature)

\_\_\_\_\_  
 (date)

\_\_\_\_\_  
 (title, organization)

-----  
 (return address)



DRAFT HANDBOOK FOR SEALS IN NAVAL AIRCRAFT

1. Did you find the Handbook useful? Yes X No
2. Does it contain sufficient detail? Yes X No
3. Did the format make the Handbook easy to use? Yes X No
4. Should the Handbook be made into a Naval Technical Manual? Yes      No X
5. Do you feel that the Handbook data is current state-of-the-art information? Yes X No
6. It is suggested that the handbook could be improved by making the following changes:

7. Reasons for suggested changes are:

8. It is further suggested that the handbook could be made more useful to users by adding material on the following (indicate sources of required information if known):

This handbook is an interesting compilation of engineering data on seals, however, it has limited use below depot level maintenance. The majority of information concerns design and selection and is not within the scope of below depot maintenance type work. Maintenance procedures for individual components must remain with the respective maintenance manuals for that component. This handbook would make excellent reference material for Naval Aircraft Rework Facility Engineering staffs and technical writers for maintenance instructions.

(3)

\_\_\_\_\_ (signature)

\_\_\_\_\_ (date)

\_\_\_\_\_ (title, organization)

----- (return address)

DRAFT HANDBOOK FOR SEALS IN NAVAL AIRCRAFT

1. Did you find the Handbook useful? Yes X No
2. Does it contain sufficient detail? Yes X No
3. Did the format make the Handbook easy to use? Yes X No
4. Should the Handbook be made into a Naval Technical Manual? Yes X No
5. Do you feel that the Handbook data is current state-of-the-art information? Yes X No
6. It is suggested that the handbook could be improved by making the following changes:

7. Reasons for suggested changes are:

8. It is further suggested that the handbook could be made more useful to users by adding material on the following (indicate sources of required information if known):

Recommend that information on T-seals be included in the Manual. T-seals manufactured by Greene-Tweed Corp., North Wales, Pa.

(4)  
\_\_\_\_\_ (signature)

\_\_\_\_\_ (date)

\_\_\_\_\_ (title, organization)

-----  
(return address)

DRAFT HANDBOOK FOR SEALS IN NAVAL AIRCRAFT

1. Did you find the Handbook useful? Yes X No
2. Does it contain sufficient detail? Yes X No
3. Did the format make the Handbook easy to use? Yes X No
4. Should the Handbook be made into a Naval Technical Manual? Yes X No
5. Do you feel that the Handbook data is current state-of-the-art information? Yes      No X
6. It is suggested that the handbook could be improved by making the following changes:

Incorporate further information on Greene-Tweed T-seals.

7. Reasons for suggested changes are:

8. It is further suggested that the handbook could be made more useful to users by adding material on the following (indicate sources of required information if known):

Suggest provide information on two stage unvented rod seals usage; source of information:

Mr. G.K. Fling  
 Supervisor Flight Controls & Fluid Systems Design  
 Vought Corporation  
 P.O. Box 5907  
 Dallas, Texas 75222  
 Phone: 214-266-5297

(5)  
 \_\_\_\_\_  
 (signature)

\_\_\_\_\_  
 (date)

\_\_\_\_\_  
 (title, organization)

-----  
 (return address)

DRAFT HANDBOOK FOR SEALS IN NAVAL AIRCRAFT

1. Did you find the Handbook useful? Yes X No
2. Does it contain sufficient detail? Yes X No
3. Did the format make the Handbook easy to use? Yes X No
4. Should the Handbook be made into a Naval Technical Manual? Yes X No
5. Do you feel that the Handbook data is current state-of-the-art information? Yes X No
6. It is suggested that the handbook could be improved by making the following changes:

7. Reasons for suggested changes are:

8. It is further suggested that the handbook could be made more useful to users by adding material on the following (indicate sources of required information if known):

- a) Under the latest revision of NAVSUP Publication 4105 (1 July 1976) the assigned shelf life limitations for rubber O-rings have been reduced from 5 years to approximately 18 months, and the shelf life limitations of rubber containing components have been extended. Paragraph 8.3 of Chapter 5 should be revised to reflect these shelf life changes for the rubber O-rings.
- b) Most seals and O-rings are identified with a packaging code, which is defined by Military Standard MIL-STD-726 for the specific type of preservation and packaging required by Military Specification MIL-P-116. These packaging codes are found in the Aviation Supply Office Milstrip Ordering Sections C0030 and P2310. Therefore, in the interest of completeness, the packaging section of each chapter should indicate that specific packaging instructions are available for all seals and O-rings.

(6)  
\_\_\_\_\_ (signature)

\_\_\_\_\_ (date)

\_\_\_\_\_ (title, organization)

----- (return address)

DRAFT HANDBOOK FOR SEALS IN NAVAL AIRCRAFT

1. Did you find the Handbook useful? Yes \_\_\_ No \_\_\_ To Whom?
2. Does it contain sufficient detail? Yes \_\_\_ No \_\_\_ For Whom?
3. Did the format make the Handbook easy to use? Yes \_\_\_ No \_\_\_ By Whom?
4. Should the Handbook be made into a Naval Technical Manual? Yes \_\_\_ No X
5. Do you feel that the Handbook data is current state-of-the-art information? Yes X No \_\_\_
6. It is suggested that the handbook could be improved by making the following changes:

The fundamental problem with the proposed handbook is exemplified by paragraph 2, page 1-1 (Introduction). It says the handbook "has been prepared to establish uniform practice (sic) in the Navy for selection, application, and maintenance of these types of seals." The people and organizations involved in seal selection are vastly different from those performing maintenance. By

~~7. Reasons for suggested changes are:~~

attempting to write one manual that is directed to everyone it is of particular use to no one--other than in an academic sense. There is a large amount of information excerpted from Navy manuals, manufacturers design manuals, Mil Specs, etc.; yet a design engineer needs far more information than is contained in the proposed manual. The fleet maintenance man, on the other hand, is totally disinterested in all of the design data and material criteria and will

~~8. It is further suggested that the handbook could be made more useful to users by adding material on the following (indicate sources of required information if known):~~

follow only the authorized practices in his NA01-XX-XX manuals. There is very little depot rework information that is not already exchanged via the distribution of LES's. In short, this manual that is apparently written for fleet, depot, and design use does not satisfy the needs for any one of these three disparate groups sufficiently to warrant its publication.

(7)  
\_\_\_\_\_  
(signature)

\_\_\_\_\_  
(date)

\_\_\_\_\_  
(title, organization)

-----  
(return address)

DRAFT HANDBOOK FOR SEALS IN NAVAL AIRCRAFT

1. Did you find the Handbook useful? Yes X No
2. Does it contain sufficient detail? Yes X No
3. Did the format make the Handbook easy to use? Yes X No
4. Should the Handbook be made into a Naval Technical Manual? Yes X No
5. Do you feel that the Handbook data is current state-of-the-art information? Yes X No
6. It is suggested that the handbook could be improved by making the following changes:

The manual was forwarded to NARF Norfolk to use in problems. Personnel using the manual were given copies of John McGrew's letter and were requested to forward their comments. Review of the manual by the various divisions of replant drew favorable comments.

7. Reasons for suggested changes are:

8. It is further suggested that the handbook could be made more useful to users by adding material on the following (indicate sources of required information if known):

\_\_\_\_\_ (8) \_\_\_\_\_  
 (signature) (date)

\_\_\_\_\_ (title, organization)

----- (return address)

DRAFT HANDBOOK FOR SEALS IN NAVAL AIRCRAFT

1. Did you find the Handbook useful? Yes X No
2. Does it contain sufficient detail? Yes X No
3. Did the format make the Handbook easy to use? Yes X No
4. Should the Handbook be made into a Naval Technical Manual? Yes X No
5. Do you feel that the Handbook data is current state-of-the-art information? Yes X No
6. It is suggested that the handbook could be improved by making the following changes:

See attached copy of letter dated February 3, 1976 to Mr. John M. McGrew, Jr. of Shaker Research Corporation.

7. Reasons for suggested changes are:

Included in attachment.

8. It is further suggested that the handbook could be made more useful to users by adding material on the following (indicate sources of required information if known):

(9)

\_\_\_\_\_ (signature)

\_\_\_\_\_ (date)

\_\_\_\_\_ (title, organization)

----- (return address)

DRAFT HANDBOOK FOR SEALS IN NAVAL AIRCRAFT

- 1. Did you find the Handbook useful? Yes X No
- 2. Does it contain sufficient detail? Yes X No
- 3. Did the format make the Handbook easy to use? Yes X No
- 4. Should the Handbook be made into a Naval Technical Manual? Yes X No
- 5. Do you feel that the Handbook data is current state-of-the-art information? Yes X No
- 6. It is suggested that the handbook could be improved by making the following changes:

7. Reasons for suggested changes are:

8. It is further suggested that the handbook could be made more useful to users by adding material on the following (indicate sources of required information if known):

(10)

\_\_\_\_\_ (signature)

\_\_\_\_\_ (date)

\_\_\_\_\_ (title, organization)

----- (return address)

DRAFT HANDBOOK FOR SEALS IN NAVAL AIRCRAFT

1. Did you find the Handbook useful? Yes\_\_\_ No\_\_\_ Too Long Winded
2. Does it contain sufficient detail? Yes\_\_\_ No\_\_\_ Too Much
3. Did the format make the Handbook easy to use? Yes\_\_\_ No X
4. Should the Handbook be made into a Naval Technical Manual? Yes\_\_\_ No\_\_\_ For Info.--  
Yes
5. Do you feel that the Handbook data is current state-of-the-art information? Yes\_\_\_ No\_\_\_ Not Completely
6. It is suggested that the handbook could be improved by making the following changes:

Correct Figure 5-1

Nitrile used from -65 to +275<sup>o</sup>F  
 Fluoroelastomer above 275<sup>o</sup>F

7. Reasons for suggested changes are:

8. It is further suggested that the handbook could be made more useful to users by adding material on the following (indicate sources of required information if known):

\_\_\_\_\_ (11) \_\_\_\_\_  
 (signature) (date)

\_\_\_\_\_ (title, organization)

----- (return address)

DRAFT HANDBOOK FOR SEALS IN NAVAL AIRCRAFT

1. Did you find the Handbook useful? Yes X No
2. Does it contain sufficient detail? Yes X No
3. Did the format make the Handbook easy to use? Yes X No
4. Should the Handbook be made into a Naval Technical Manual? Yes X No
5. Do you feel that the Handbook data is current state-of-the-art information? Yes X No
6. It is suggested that the handbook could be improved by making the following changes:
  - a) Page 2-30, line 2, add, "Federal Specification" before "PD-680".
  - b) Page 3-31, para d), change last sentence to read, "Circumferential seals should as a general rule be packaged in a heat sealed bag manufactured from material with a low WVTR (Water Vapor Transmission Rate)."
  - c) Page 4-53, lip seal packaging, para 1), change para 1) to read, "Wrap each seal in a chemically neutral wrap and then place on a corrugated pad."
- ~~7. Reasons for suggested changes are:~~
  - d) Page 6-19, "MIL-S-880217" should be "MIL-S-8802."

8. It is further suggested that the handbook could be made more useful to users by adding material on the following (indicate sources of required information if known):
  - a) Add definitions section.
  - b) Add explanation of abbreviations section.
  - c) Delete revision letters of Federal and Military Specifications.
  - d) Page 2-27, paragraph 8.0, add a more comprehensive section concerning rework methods and materials for carbon seals.

(12)

\_\_\_\_\_ (signature)

\_\_\_\_\_ (date)

\_\_\_\_\_ (title, organization)

----- (return address)

DRAFT HANDBOOK FOR SEALS IN NAVAL AIRCRAFT

1. Did you find the Handbook useful? Yes X No \_\_\_
2. Does it contain sufficient detail? Yes X No \_\_\_
3. Did the format make the Handbook easy to use? Yes X No \_\_\_
4. Should the Handbook be made into a Naval Technical Manual? Yes X No \_\_\_
5. Do you feel that the Handbook data is current state-of-the-art information? Yes X No \_\_\_
6. It is suggested that the handbook could be improved by making the following changes:

None

7. Reasons for suggested changes are:

8. It is further suggested that the handbook could be made more useful to users by adding material on the following (indicate sources of required information if known):

None

(13)

\_\_\_\_\_

(signature)

\_\_\_\_\_

(date)

\_\_\_\_\_

(title, organization)

-----

(return address)

## DRAFT HANDBOOK FOR SEALS IN NAVAL AIRCRAFT

1. Did you find the Handbook useful? Yes  No
2. Does it contain sufficient detail? Yes  No
3. Did the format make the Handbook easy to use? Yes  No
4. Should the Handbook be made into a Naval Technical Manual? Yes  No
5. Do you feel that the Handbook data is current state-of-the-art information? Yes  No
6. It is suggested that the handbook could be improved by making the following changes:

7. Reasons for suggested changes are:

8. It is further suggested that the handbook could be made more useful to users by adding material on the following (indicate sources of required information if known):

See attached letter and enclosures.

(14)

\_\_\_\_\_  
(signature)

\_\_\_\_\_  
(date)

\_\_\_\_\_  
(title, organization)

-----  
(return address)

DRAFT HANDBOOK FOR SEALS IN NAVAL AIRCRAFT

1. Did you find the Handbook useful? Yes \_\_\_ No X
2. Does it contain sufficient detail? Yes X No \_\_\_
3. Did the format make the Handbook easy to use? Yes X No \_\_\_
4. Should the Handbook be made into a Naval Technical Manual? Yes \_\_\_ No X
5. Do you feel that the Handbook data is current state-of-the-art information? Yes X No \_\_\_
6. It is suggested that the handbook could be improved by making the following changes:

7. Reasons for suggested changes are:

8. It is further suggested that the handbook could be made more useful to users by adding material on the following (indicate sources of required information if known):

9. Comment: The information in the handbook is considered useful during consideration for new equipment and during ECP preparation. CFAs could also use this information for review and possible revisions to maintenance manuals and illustrated parts breakdowns, but in no way should it be used on a trial basis by naval personnel to select and apply seals. Strict adherence to established maintenance procedures is the only method approved for naval personnel.

\_\_\_\_\_  
 (15)  
 (signature)

\_\_\_\_\_  
 (date)

\_\_\_\_\_  
 (title, organization)

-----  
 (return address)

DRAFT HANDBOOK FOR SEALS IN NAVAL AIRCRAFT

1. Did you find the Handbook useful? Yes X No
2. Does it contain sufficient detail? Yes X No
3. Did the format make the Handbook easy to use? Yes X No
4. Should the Handbook be made into a Naval Technical Manual? Yes      No      (?)
5. Do you feel that the Handbook data is current state-of-the-art information? Yes X No
6. It is suggested that the handbook could be improved by making the following changes:

7. Reasons for suggested changes are:

8. It is further suggested that the handbook could be made more useful to users by adding material on the following (indicate sources of required information if known):

(16)

---

(signature)
(date)

---

(title, organization)

---

(return address)

APPENDIX C

Recommended Changes

C-1 INTRODUCTION

No changes recommended.

C-2 FACE SEALS

- 1) On Page 2-10, Figure 2-4: The exact nature of pressure loading of the seal is not completely explained.
- 2) Page 2-12 (1st full paragraph): Another effect of improper O-ring squeeze is O-ring roll which can cause seal leakage, shorten the seal life, or hang-up the sealing nose.
- 3) Page 2-21: Carbon-graphite materials and manufacturers are a study unto themselves. Most high temperature carbon-graphite materials are treated with impregnants. As carbon-graphite is hydroscopic, certain grades will exude the impregnant and cause the sealing element to become stuck together. This is particularly dangerous for circumferential seals.

Most manufacturers of carbon-graphite will not divulge their manufacturing process and will not even tell what materials are in a particular material grade. Most seal manufacturers/designers must rely on their experience and recommendations of the carbon manufacturer for material selection. This is a particularly undesirable circumstance. Data should be compiled on all carbon-graphite grades to be considered for aircraft use. This data should include physical, chemical, and operational test results.

- 4) Page 2-27: Disassembly (also for Circumferential Seals): At a slight cost penalty, most seals can be made so they can be disassembled with relative ease. Seals can be refurbished at significant cost savings. Many seals supplied do not include this take-apart feature and slight damage to seals generally results in scrapping out expensive and potentially repairable hardware.

C-3 CIRCUMFERENTIAL SEALS

- 1) Page 3-1, Circumferential Seals work very well in air-oil mist applications.
- 2) On Pages 3-3, 3-5, 3-6, 3-7, 3-8, 3-17, 3-19, and 3-26: Acknowledgement should read: "Gould Inc., Engine Parts Division"
- 3) On Page 3-41. This dot system of marking carbon elements for orientation was developed and is used by Gould Inc. Other manufacturers may not conform.

C-4 LIP SEALS

No changes recommended.

C-5 O-RINGS

- 1) Page 5-2, Figure 5-1: Nitrile used from -65 to 275° F; flouroelastomer used above 275° F.
- 2) Page 5-11, paragraph no. 3, 10, second paragraph: It would probably be helpful to add the explanation here that backup rings prolong the normal wear life of an O-ring, even at lower pressures, because they help to trap lubricants, thus reducing friction.
- 3) Page 5-15 Size -115: The O.D. dimension should be .880 rather than .861.
- 4) Page 5-15 through 5-18: Footnote (1) should be deleted because the inside diameter tolerances shown in this table have not been changed, and neither have the tolerances on drawing MS28775, though we expect that the tolerances on all military O-ring series will be changed to the new standard in a short time. (Three of the newer series, M83248, M25988 and M83461 do have the new tolerances.) Perhaps a better note would be, "O-ring inside diameter tolerances are in the process of being changed to agree with AS568A. For most sizes this will be an increase over the tolerances listed in this table."
- 5) Page 5-21 Tube Fitting Boss Seals: Parker Seal recommends the use of the MS16142 boss, shown in Table A5-4 of the Parker O-ring handbook in preference to the MS33649 boss shown here. The MS16142 boss is made to closer tolerances, it deforms the O-rings less drastically, and as a result it produces more reliable sealed joints.

- 6) Page 5-28 through 5-31 Footnote (1): A comment similar to that for pages 5-15 through 5-18 applies here except that in this chart the O-ring series is an "industrial" series rather than a military series. We are already using the new tolerances on these O-rings, through the table shows the old tolerances. It is not clear from the footnote which tolerances are shown.

The change occurred after the Handbook was ready to go to the printers. Rather than cause further lengthy delays to incorporate it throughout, we handled it by this note, referring to the table where the new tolerances were shown. Perhaps you will want to incorporate the new tolerances here with a note indicating the fact.

- 7) Page 5-32, paragraph no. 5.1, Pressure Capability: The maximum pressure recommended for rotary seals in the Parker O-ring Handbook is 800 psi. The maximum pressure limit for any O-ring seal depends on the hardness of the compound, the size of the extrusion gap, and the temperature. The rotary seal design calls for an 80 durometer compound, a diametral clearance up to .080 inch, and a maximum temperature that may approach 250°F. It is under these conditions, plus the fact of the rotary shaft, that the maximum recommended pressure is 800 psi. For static or reciprocating applications in which the clearance is kept much smaller, pressure up to 1500 psi is acceptable (see title of Table 5-1, page 5-15), and higher pressure can be attained when backup rings are used. This paragraph should not apply to rotary applications, yet there is a reference to Table 5-4.
- 8) Page 5-35, Figure 5-22: Corrections needed per attached Xerox of the page.
- 9) Page 5-36, Table 5-5; Speed 0 to 200 FPM: Reference should be to Table 5-1 (Military Hydraulic) rather than Table 5-4. (Table 5-4 applies for higher speeds, however.)
- 10) Page 5-39: At the end of the second paragraph show MIL-R-83248 rather than MIL-R-25897.
- 11) Page 5-42, Table 5-7: Add MIL-P-83461 - Packings Petroleum Hydraulic Fluid Resistant, improved performance at 275°F (135°C).

- 12) Page 5-43, Table 5-8: Add M83461/1; Nitrile (Buna N); 75; -65 to 275°F; MIL-P-93461; Hydraulic Oil, MIL-H-5606.
- 13) Page 5-46, paragraph 6, 5, second sentence: The MS28775-214 O-ring has an inside diameter of .984, and these rings meet the requirements of MIL-P-25732 rather than MIL-P-5516.
- 14) Page 5-47 and 5-48, Table 5-9: Specification MIL-P-5516 is now inactive for new design. It would therefore be preferable to show the superseding specification, MIL-P-25732 (or MIL-P-83461) on these pages.
- 15) Page 5-60, paragraph 8.1; O-ring identification: Delete the whole paragraph because the military services have discontinued color code identification. (It was controlled by ANA bulletin 419 and the individual specifications and series drawings.)
- 16) Page 5-61, Figure 5-31; O-ring color coding: Delete for the same reason.
- 17) Page 5-62, paragraph 8.3: Under the latest revision of NAVSUP Publication 4105 (1 July 1976) the assigned shelf life limitations for rubber O-rings have been reduced from 5 years to approximately 18 months, and the shelf life limitations of rubber containing components have been extended. This paragraph should be revised to reflect these shelf life changes for the rubber O-rings.
- 18) Page 5-64, paragraph 9.0, no. 1: The Parker O-ring Handbook number is OR5700 and the material was from the 1975 edition.

C-5 FORM-IN-PLACE SEALS

No changes recommended.

C-6 REVIEW OF NAVAL SEAL PRACTICE

The following comments were made on the companion document to the draft handbook, "Review of Seal Maintenance Problems on Naval Aircraft."

- 1) Seal manufacturers receive very little information regarding the performance of their seals in military aircraft. Without feedback,

there are no actions taken to improve a particular application.

- 2) While the report indicates that carbon seals contribute to 95% of helicopter problems, it does not say that carbon seals are used where operating conditions are most severe.
- 3) Under recommendations, the report states that positive lubrication will improve seal life. Nowhere in the report is it indicated that seals fail because of carbon wear. While this may be true, maybe the nature and reasons for failure should be tabulated and further analyzed.
- 4) The data presented on Page 28 are not for the circumferential seal. The seals you are referring to are in fact lip seals which are also being tested. These seals are lip seals with a sine-wave pattern on the lip rather than the more conventional helix pattern. Those seals are being tested for Dr. R. Singler, U.S. Army Materiels Mechanics Research Center, Watertown, MA 02172. Since your report, another lip seal with 257 flight hours has failed.

At present, the U.S. Army is flight testing two of the circumferential type seals in a UH-1 transmission. One of the seals has accumulated 637 hours to date with no adverse results. The other circumferential seal was flight tested at Bell Helicopter for 179 hours and has now been installed in a UH-1 transmission at Ft. Ruckers for further flight testing.

Besides these two seals, Bell Helicopter has tested this circumferential type seal in their 214 helicopter. They have accumulated over 300 hours of flight testing which includes a 200 hour Air Worthiness Qualification Test in the 214 helicopter input transmission.

- 5) Page 31, paragraph 6 and Page 32: Both "lead ins" here indicated are inadequate. With the O-ring seated on the 1.757 groove diameter of the hub, its outside diameter will be approximately 2.037 inches as it is being pushed into the end plate bore. The diameter across the lead-in chamfer should be at least this large to prevent pinching the O-ring. The end plate bore is probably 2.000 inches, requiring a chamfer length of at least .061 inch for a 15° chamfer. The geometry is illustrated

in Figure C-1. If there is not room for a chamfer this long, a .016 inch radius would be preferable to the tiny chamfer presently called for.

- 6) Page 44, paragraph 6.1.1.2: O-rings are not normally recommended for sealing rotary shaft except where the speed is low. However, a low limit of 8 in/sec (40'/min) seems excessively low. Is this perhaps due to some peculiarity of the "Rev-O-" seal design? If so, it should be stated, otherwise there will be confusion between this statement and Table 5-5 page 5-36 of Appendix B suggesting O-rings for speeds up to 1500' per minute if the glands are properly designed.
  
- 7) Page 52, Type II Systems: Under government contract, nitrile O-ring compounds have been developed which have completed 1000 hour performance tests at temperatures ranging from -65 to +275°F and pressures from 50 to 3000 psig in both rod and piston type test rigs. It is a definite improvement over earlier compounds for Type III systems, and specification MIL-P-83461 has been established based on the properties of this material. Parts may be ordered under series no. M83461/1 or by the Parker 2- series number and the production compound number N756-75. The experimental number was AFE-XN1925-33. Reports on the development project may be obtained from Air Force Materials Laboratory, Nonmetallic Materials Division, Elastomers and Coatings Branch, AFML/MBE, Wright-Patterson Air Force Base, Ohio 45433. Ask for "Long Life Elastomeric Aircraft Hydraulic Seals Technical Reports AFML-TR-22-66 and AFML-TR-73-90, Parts I and II.

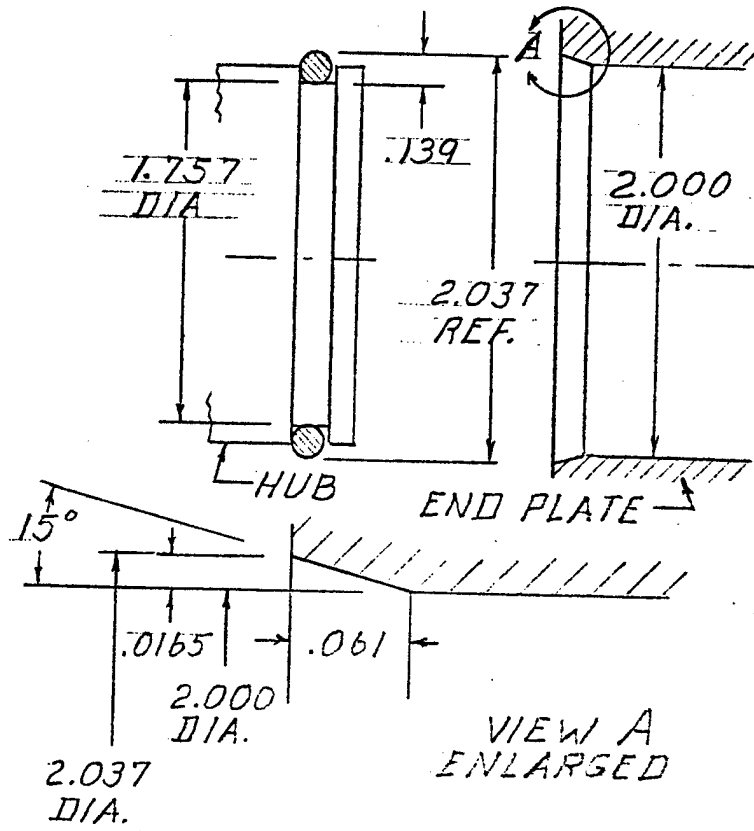

Figure C-1

REPORT DOCUMENTATION PAGE		READ INSTRUCTIONS BEFORE COMPLETING FORM
1. REPORT NUMBER <b>NADC-76070-30</b>	2. GOVT ACCESSION NO.	3. RECIPIENT'S CATALOG NUMBER
4. TITLE (and Subtitle)  <b>Evaluation of Draft Handbook for Seals in Naval Aircraft</b>		5. TYPE OF REPORT & PERIOD COVERED  <b>Interim</b>
		6. PERFORMING ORG. REPORT NUMBER
7. AUTHOR(s)  <b>J. M. McGrew</b>		8. CONTRACT OR GRANT NUMBER(s)  <b>N62269-76-M-2530</b>
9. PERFORMING ORGANIZATION NAME AND ADDRESS <b>Shaker Research Corporation Northway 10 Executive Park Ballston Lake, New York 12019</b>		10. PROGRAM ELEMENT, PROJECT, TASK AREA & WORK UNIT NUMBERS  <b>Air Task WR5-109 Work Unit Number GA-801</b>
11. CONTROLLING OFFICE NAME AND ADDRESS <b>Analytical Rework/Service Life Project Office Air Vehicle Technology Department Naval Air Development Center, Warminster, Pa.</b>		12. REPORT DATE <b>September 1976</b>
		13. NUMBER OF PAGES <b>48</b>
14. MONITORING AGENCY NAME & ADDRESS (if different from Controlling Office)		15. SECURITY CLASS. (of this report)  <b>Unclassified</b>
		15a. DECLASSIFICATION/DOWNGRADING SCHEDULE
16. DISTRIBUTION STATEMENT (of this Report)		
17. DISTRIBUTION STATEMENT (of the abstract entered in Block 20, if different from Report)		
18. SUPPLEMENTARY NOTES		
19. KEY WORDS (Continue on reverse side if necessary and identify by block number)  <b>Seals, O Rings, Face Seals, Circumferential Seals, Form-In-Place Seals</b>		
20. ABSTRACT (Continue on reverse side if necessary and identify by block number)  <b>Under Contract N62269-74-C-0379, Shaker Research Corporation has prepared a Handbook for Seals in Naval Aircraft. The manual has been distributed in draft form. The objective of the work described here was to solicit comments and suggestions on the draft manual from recipients of the distribution list, and to correlate and evaluate all such comments and suggestions. The report provides a summary of the recommendations, along with supporting rationale, as to what items should be included in the final manual to be issued.</b>		