

LOAN DOCUMENT

DTIC ACCESSION NUMBER		PHOTOGRAPH THIS SHEET											
	LEVEL		INVENTORY										
	DOCUMENT IDENTIFICATION												
DISTRIBUTION STATEMENT													
<table border="1"><tr><td colspan="2">ACCESSION FOR</td></tr><tr><td>NTIS</td><td>GRAM</td></tr><tr><td>DTIC</td><td>TRAC</td></tr><tr><td>UNANNOUNCED</td><td></td></tr><tr><td>JUSTIFICATION</td><td></td></tr></table>		ACCESSION FOR		NTIS	GRAM	DTIC	TRAC	UNANNOUNCED		JUSTIFICATION		DATE ACCESSIONED	
ACCESSION FOR													
NTIS	GRAM												
DTIC	TRAC												
UNANNOUNCED													
JUSTIFICATION													
BY													
DISTRIBUTION/													
AVAILABILITY CODES													
<table border="1"><tr><th>DISTRIBUTION</th><th>AVAILABILITY AND/OR SPECIAL</th></tr><tr><td style="text-align: center; vertical-align: middle;">A-1</td><td></td></tr></table>		DISTRIBUTION	AVAILABILITY AND/OR SPECIAL	A-1		DATE RETURNED							
DISTRIBUTION	AVAILABILITY AND/OR SPECIAL												
A-1													
DISTRIBUTION STAMP													
Reproduced From Best Available Copy													
19981223 019		REGISTERED OR CERTIFIED NUMBER											
DATE RECEIVED IN DTIC													
PHOTOGRAPH THIS SHEET AND RETURN TO DTIC-FDAC													

H
A
N
D
L
E

W
I
T
H

C
A
R
E

UNCLASSIFIED

12-19-78

NO DISTRIBUTION
STATEMENT

NADC

Tech. Info.

APPENDIX 33

IFMR - TG INTERFACE

FINAL SOFTWARE REPORT

DATA ITEM NO. A005

INTEGRATED ELECTRONIC WARFARE SYSTEM ADVANCED DEVELOPMENT MODEL (ADM)

780098733

PREPARED FOR:

NAVAL AIR DEVELOPMENT CENTER
WARMINSTER, PENNSYLVANIA

CONTRACT NO 2269-75-C-0070



ELECTROMAGNETIC
SYSTEMS DIVISION

1 OCTOBER 1977

UNCLASSIFIED

APPENDIX 33

IFM RECEIVER/ TECHNIQUES GENERATOR INTERFACE
FINAL SOFTWARE REPORT

DATA ITEM A005

INTEGRATED ELECTRONIC WARFARE SYSTEM (IEWS)
ADVANCED DEVELOPMENT MODEL (ADM)

Contract No. N62269-75-C-0070

Prepared for:

Naval Air Development Center
Warminster, Pennsylvania

Prepared by:

RAYTHEON COMPANY
Electromagnetic Systems Division
6380 Hollister Avenue
Goleta, California 93017

1 OCTOBER 1977

IFMR/TG INTERFACE
INTERFACE CONTROL UNIT1.0 SCOPE

This document shall describe the interface between the IFMR (IIU) and the TECHNIQUES GENERATOR. The functional as well as the detailed physical requirements shall be included in this document.

2.0 APPLICABLE DOCUMENTS

IEWS ICD 53959-NK-1400

IEWS ICD 53959-DB-1011

3.0 REQUIREMENTS

An interface shall be established between the IFMR (IIU) and the Techniques Generator to enable the transfer of VCO RF signals and RF switch control lines. The Techniques Generator also communicates with IFMR via the Parameter Encoder on the IFMR BUS, see ICD 53959-DB-1011. The IFMR /TG interface shall be organized as shown in Figure 1.

3.2 PERFORMANCE REQUIREMENTS3.2.1 IFMR Timing

Each VCO set on process shall require less than 3 μ sec of the IFMR measurement time. The control timing shall be as shown in Figure 2.

3.3 DATA STRUCTURE

The IFMR/TG interface, as shown in Figure 3, shall consist of:

2 VCO RF lines

3 RF switch control lines

VCO 01

VCO 02

BLANK

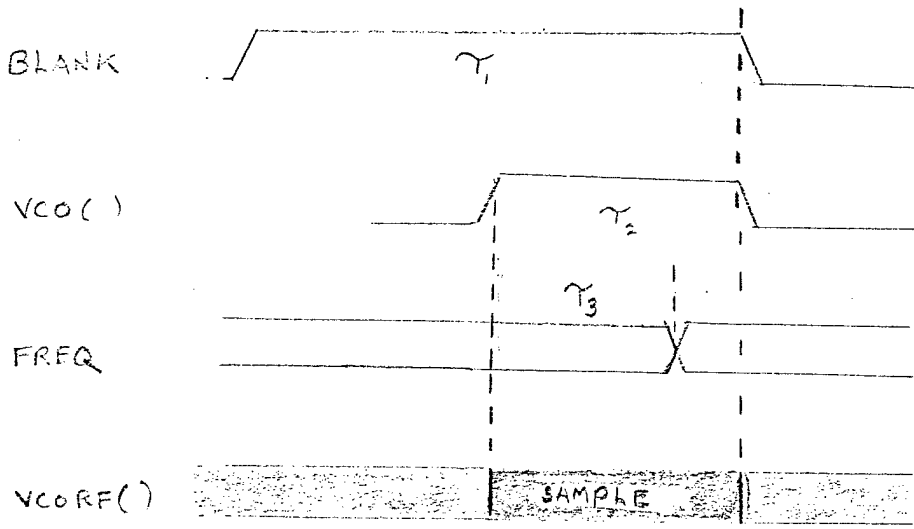

τ_1 1 μ sec
 τ_2 .5 μ sec
 τ_3 .35 μ sec

FIGURE 2 TIMING

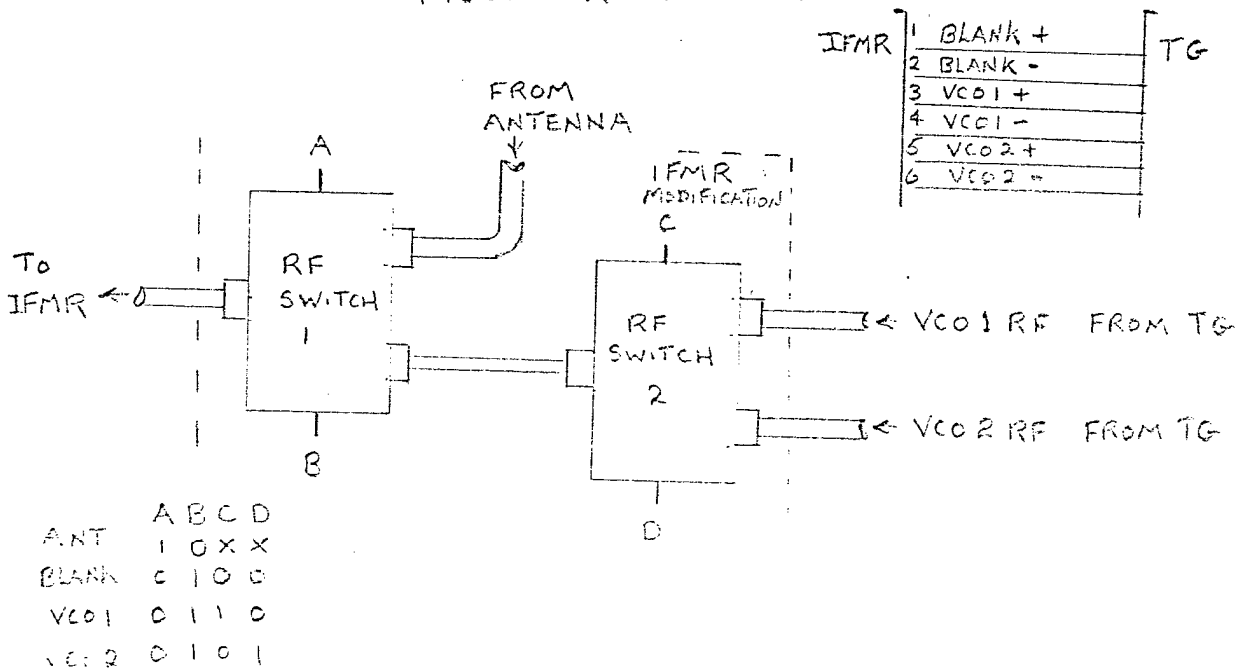

FIGURE 3 IFMR/TG INTERFACE

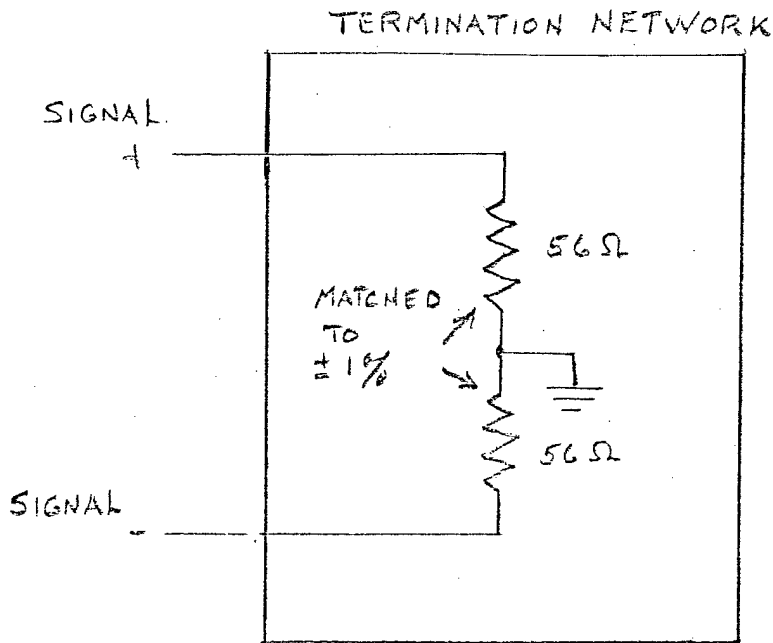
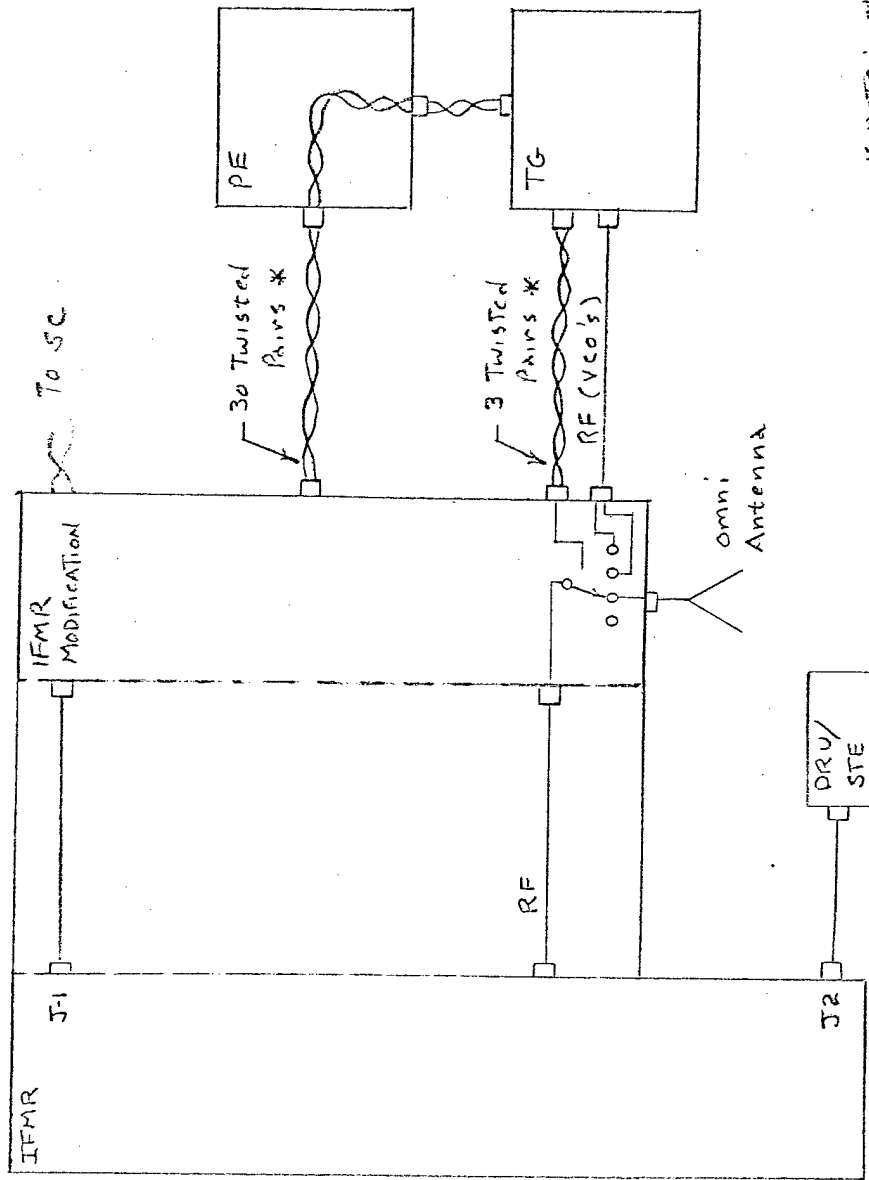

FIGURE 4 IFMR TERMINATION



* note: # 24 AWG
 $Z_0 = 110 \Omega \pm 10\%$

FIGURE 1 IFMR / TG INTERFACE

3.4 DESIGN REQUIREMENTS

3.4.1 Line Drivers/Line Receivers

All line drivers and line receivers shall incorporate SN75110 and SN75107A type devices respectively. The IFMR output shall be terminated on both ends with the termination network specified in Figure 4.

3.4.2 Interconnecting Transmission Lines

All interconnection cables used for this interface shall utilize twisted pair. The characteristic impedance shall be $110\Omega \pm 5\%$. A termination plug shall be provided which is a matched pair ($\pm 1\%$) of 56 ohm resistors for each signal and its return as shown in Figure 4.

3.4.3 Interface Signal Definition

Figure 3 provides the interface signals between the IFM and the Techniques Generator. Signals VCO 00+ and VCO 00- are the signal and the return respectively.

BLANK - a logic signal generated prior to the transmission of VCO RF which inhibits RF inputs to the IFMR.

VCO - 1 - A logic signal which selects VCO1 as the RF source for IFMR frequency measurements.

VCO - 2 - A logic signal which selects VCO2 as the RF source for IFMR frequency measurements.

VCO - 1 RF - An RF signal sent to the IFMR for frequency measurement.

VCO - 2 RF - An RF signal sent to the IFMR for frequency measurement.