

LOAN DOCUMENT

	DTIC ACCESSION NUMBER		PHOTOGRAPH THIS SHEET																					
		LEVEL		INVENTORY																				
DOCUMENT IDENTIFICATION																								
DISTRIBUTION STATEMENT																								
<table border="1"><tr><td colspan="2">ACCESSION BY</td></tr><tr><td>NTIS</td><td>GRAM <input checked="" type="checkbox"/></td></tr><tr><td>DTIC</td><td>TRAC <input checked="" type="checkbox"/></td></tr><tr><td>UNANNOUNCED</td><td><input type="checkbox"/></td></tr><tr><td>JUSTIFICATION</td><td></td></tr><tr><td colspan="2">BY</td></tr><tr><td colspan="2">DISTRIBUTION/</td></tr><tr><td colspan="2">AVAILABILITY CODES</td></tr><tr><td>DISTRIBUTION</td><td>AVAILABILITY AND/OR SPECIAL</td></tr><tr><td>A-1</td><td></td></tr></table>		ACCESSION BY		NTIS	GRAM <input checked="" type="checkbox"/>	DTIC	TRAC <input checked="" type="checkbox"/>	UNANNOUNCED	<input type="checkbox"/>	JUSTIFICATION		BY		DISTRIBUTION/		AVAILABILITY CODES		DISTRIBUTION	AVAILABILITY AND/OR SPECIAL	A-1		DATE ACCESSIONED		
ACCESSION BY																								
NTIS	GRAM <input checked="" type="checkbox"/>																							
DTIC	TRAC <input checked="" type="checkbox"/>																							
UNANNOUNCED	<input type="checkbox"/>																							
JUSTIFICATION																								
BY																								
DISTRIBUTION/																								
AVAILABILITY CODES																								
DISTRIBUTION	AVAILABILITY AND/OR SPECIAL																							
A-1																								
DISTRIBUTION STAMP		DATE RETURNED																						
DATE RECEIVED IN DTIC		REGISTERED OR CERTIFIED NUMBER																						
PHOTOGRAPH THIS SHEET AND RETURN TO DTIC-FDAC																								

H
A
N
D
L
E

W
I
T
H

C
A
R
E

Reproduced From
Best Available Copy

19981223 032

Library Copy

FINAL REPORT NO. NADC-78061-30

CONTRACT NO. N62269-78-M-6902

11 APRIL TO 11 NOVEMBER 1978

INVESTIGATION OF FAST ADAPTIVE ARRAY TECHNIQUES
FOR ADVANCED COMMUNICATION SYSTEMS

NADC

ANDREW E. ZEGER

BURTON S. ABRAMS

Tech. Info.

ZEGER-ABRAMS INCORPORATED
1112 CLARK ROAD
PHILADELPHIA, PA. 19118

NO DISTRIBUTION
STATEMENT

7800894

PREPARED FOR
NAVAL AIR DEVELOPMENT CENTER
ARMINSTER, PA. 18974

TABLE OF CONTENTS

	<u>Section Title</u>	<u>Page</u>
1.0	Summary of Adaptive Array Basics	1
1.1	Number of Nulls	1
1.2	Adaptive Arrays Controlled by the LMS Gradient Controlled Algorithm	1
1.3	Complex Weight Implementation	4
1.4	Nulling Characteristics of Adaptive Array -N Curve	4
1.5	Bandwidth Limitations on Null Depth -M Effect	7
1.6	Noncancellation Regions with a Main Antenna Adaptive Array	11
1.7	Acquisition Time	12
1.8	Related Systems - The Radar Sidelobe Canceller and The Interference Cancellation System	12
1.9	A Spread Spectrum Adaptive Array	14
2.0	Applications of Fast Adaptive Array Technology	18
2.1	State of the Art in Fast Adaption	18
2.2	Application of a Fast AA to TDMA	22
2.3	Fast Array Techniques for Frequency-Hopped Receivers	24
2.4	Fast AA for Nulling Numerous Impulse - Type Jammers	28
3.0	Recommendations for Fast AA Development	31
3.1	Multiple Impulse Jammer Network Analysis	31
3.2	Breadboard Fast AA for FH Receiver	31
	References	32

LIST OF ILLUSTRATIONS

	<u>Figure Title</u>	<u>Page</u>
1.	Adaptive Nulling Array Employing the Least Mean Squares (LMS) Algorithm	2
2.	Block Diagram of Modified LMS Adaptive Array	3
3.	Complex Weight Implementation	5
4.	Nulling Characteristic of Adaptive Array	6
5.	Nulling Performance of a Three-Element Adaptive Array	8
6a.	Broadband Jammer Power Spectral Density	9
6b.	Power Spectral Density After Nulling	9
7.	Achievable Nulling Ratio vs. Jammer Bandwidth	10
8.	Adaptive Array Acquisition Time	13
9.	Sidelobe Canceller Block Diagram	15
10.	Interference Cancellation System Block Diagram	16
11.	Adaptive Array for Spread Spectrum Systems	17
12.	Fast AA for Frequency Hopped TDMA Communications	23
13.	Front End for Each Adaptive Array Channel in a Tunable FH Receiver	26

1.0 SUMMARY OF ADAPTIVE ARRAY BASICS

1.1 Number of Nulls

An adaptive array with N weighted elements has N degrees of freedom, which can be distributed to allow jammer nulling or as constraints for desired signal maintenance. If all N elements are weighted, then at least one constraint is needed to prevent the weights from all going to zero, so that the array can form up to N-1 independently steerable nulls. If there is an unweighted main antenna, with N weighted elements, no constraint is required to prevent the all-zero solution, so the array can form up to N independently steerable nulls.

1.2 Adaptive Arrays Controlled by the LMS, Gradient Controlled Algorithm

The LMS algorithm [1] employs feedback control to adjust the array weights to minimize the mean square error E between the array output and a desired signal response. With \vec{W} representing the complex weight vector, the system equation is

$$\dot{\vec{W}} = -k \nabla_w |\epsilon|^2 = -2k \epsilon \vec{x}^*$$

where k is a gain (or step size factor) and ∇_w represents the gradient with respect to W, and \vec{x}^* is the complex conjugate of the vector of signals received at each weight input.

A block diagram of an LMS adaptive array is given in Figure 1. A modified LMS adaptive array is sketched in Figure 2 in which a main antenna input replaces the desired signal reference, and the integrator is replaced by a narrowband filter.

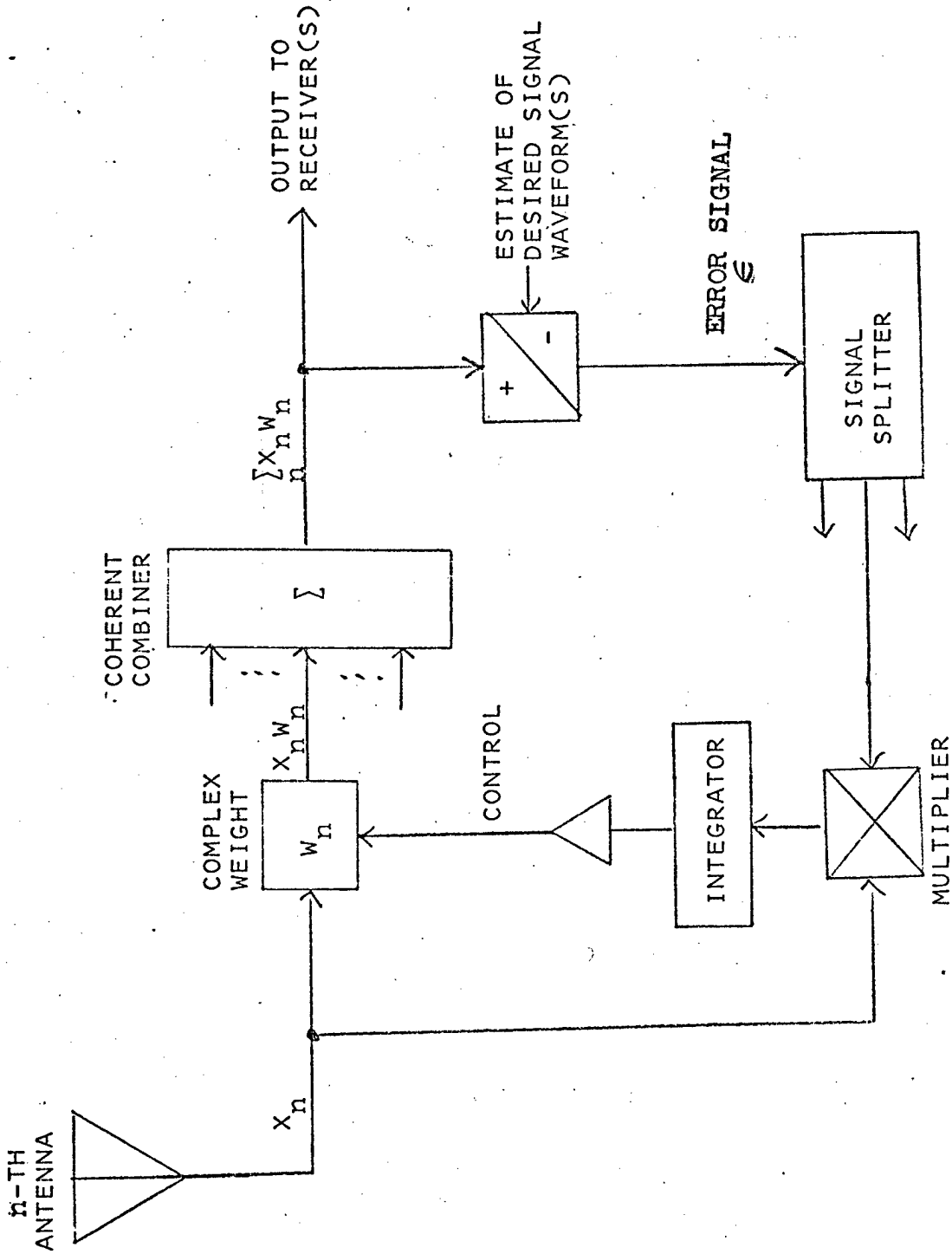

FIGURE 1 ADAPTIVE NULLING ARRAY EMPLOYING THE
LEAST MEAN SQUARES (LMS) ALGORITHM

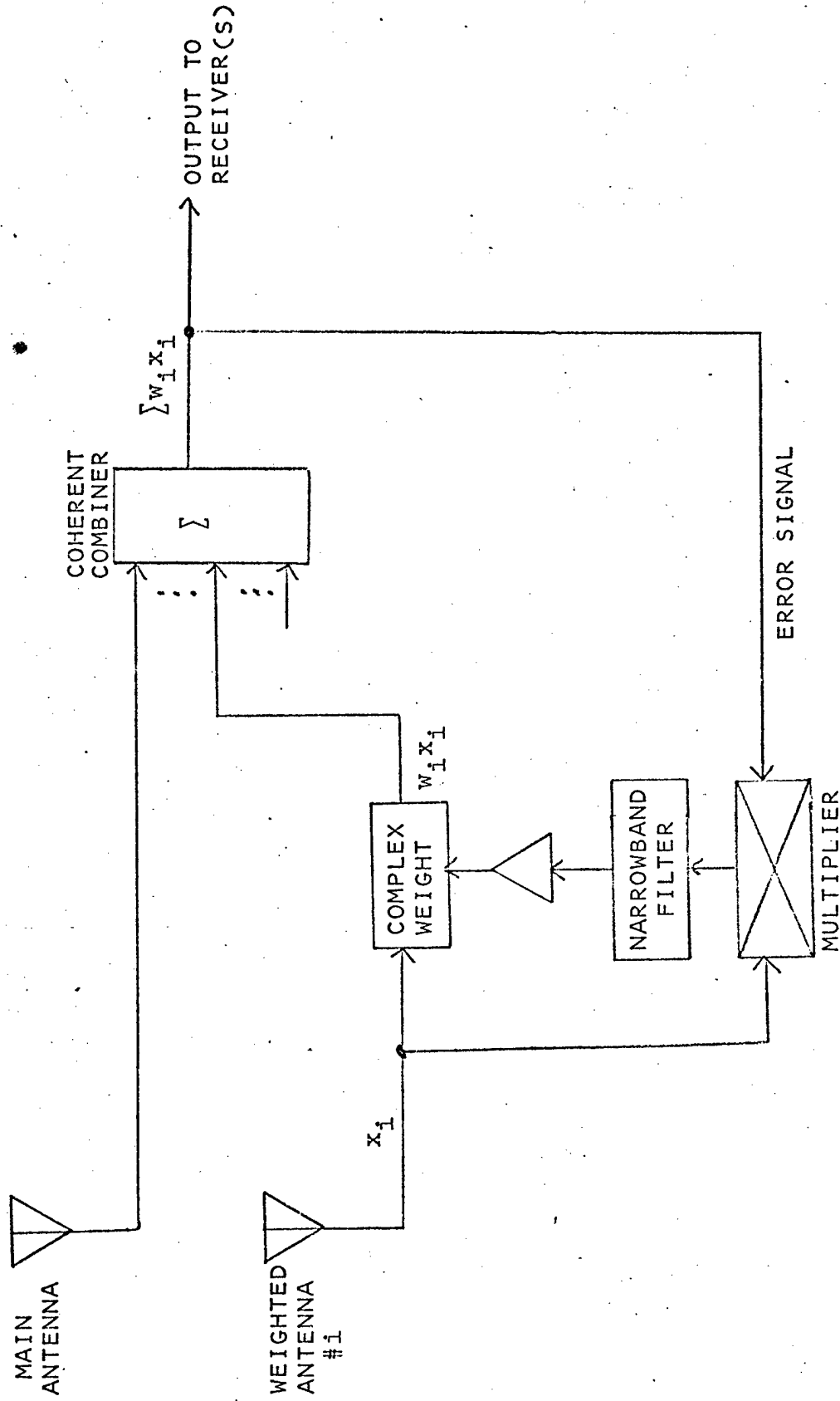

FIGURE 2
BLOCK DIAGRAM OF MODIFIED LMS ADAPTIVE ARRAY

1.3 Complex Weight Implementation

The complex weight may be implemented in polar coordinates with a variable attenuator and 360° phase shifter, or in rectangular coordinates as shown in Figure 3. This implementation is preferred because both control inputs (W_I and W_Q) are processed identically. The RF or IF input is split into two quadrature channels, each of which is adjusted in amplitude by a real bipolar weight (bipolar in the sense that the sign can be + or -), the outputs of which are combined in phase to form the complex weight output. A PIN diode implementation of the bipolar attenuator allows it to be built with low intermodulation distortion.

1.4 Nulling Characteristics of Adaptive Array - N Curve

The adaptive array nulling behavior is characterized by the N-shaped curve given in Figure 4. It is derived in [2] for a single jammer scenario with a two-element array with one element unweighted, and with a narrowband filter in the control loop. A low level input is not nulled. When the input level exceeds a threshold power level P_T , nulling begins. This is due to the fact that an input level below P_T produces a feedback loop gain below unity, so the LMS feedback loop does not respond.

The closed loop voltage gain is equal to P_{in}/P_T , so that for $P_{in} > P_T$, a stronger input actually comes out weaker in the reciprocal suppression region of the N curve. This region is eventually terminated by noise effects in the loop amplifiers, or by broadband null depth limitations. Thus, the loop gain is one of the limits on null depth.

$$|W_I|, |W_Q| \leq 1$$

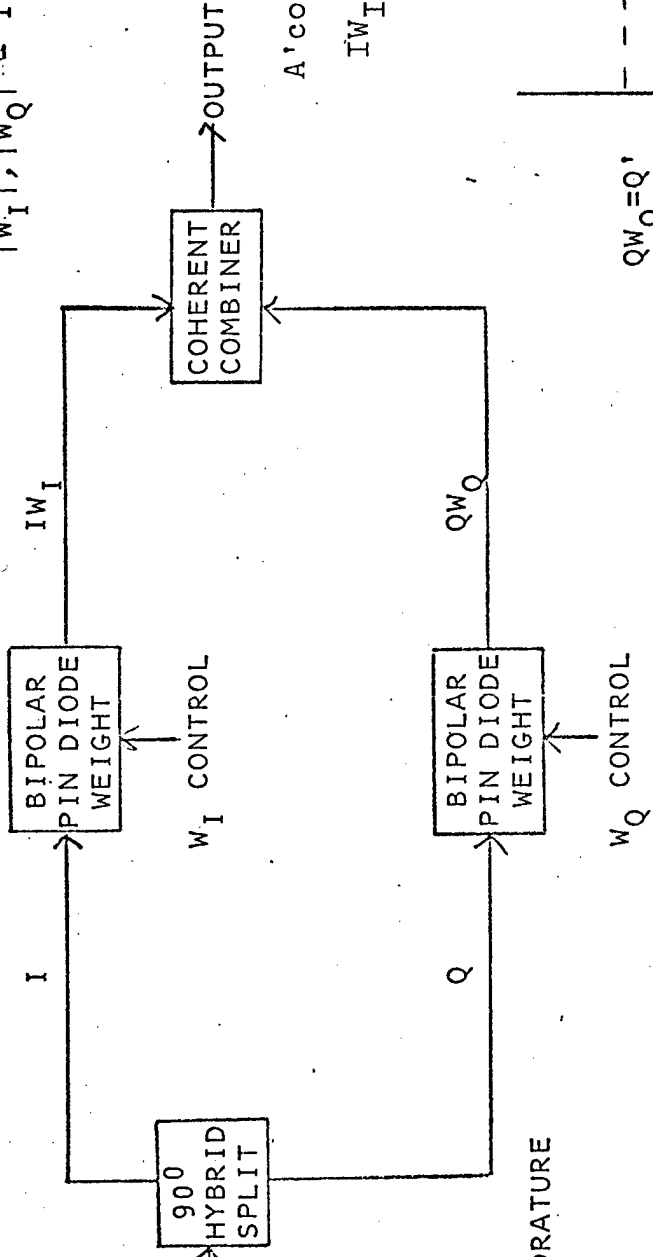

$$A' \cos(\omega_0 t + \phi') = I' W_I \cos \omega_0 t - Q' W_Q \sin \omega_0 t$$

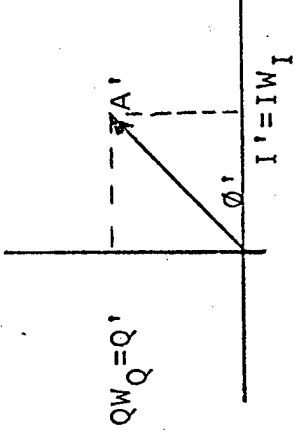
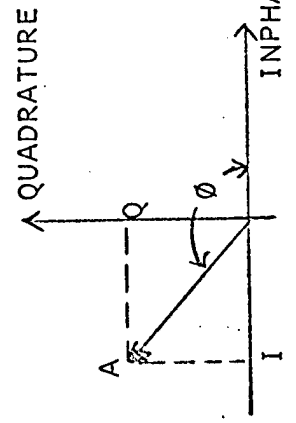

FIGURE 3

COMPLEX WEIGHT IMPLEMENTATION

FIGURE 4

NULLING CHARACTERISTIC OF ADAPTIVE ARRAY

$$P_{OUT} = \frac{P_{IN}}{(1 + P_{IN}/P_T)^2} + \text{NOISE TERMS}$$

MEAN SQUARE OUTPUT POWER P_{OUT} (DBM)

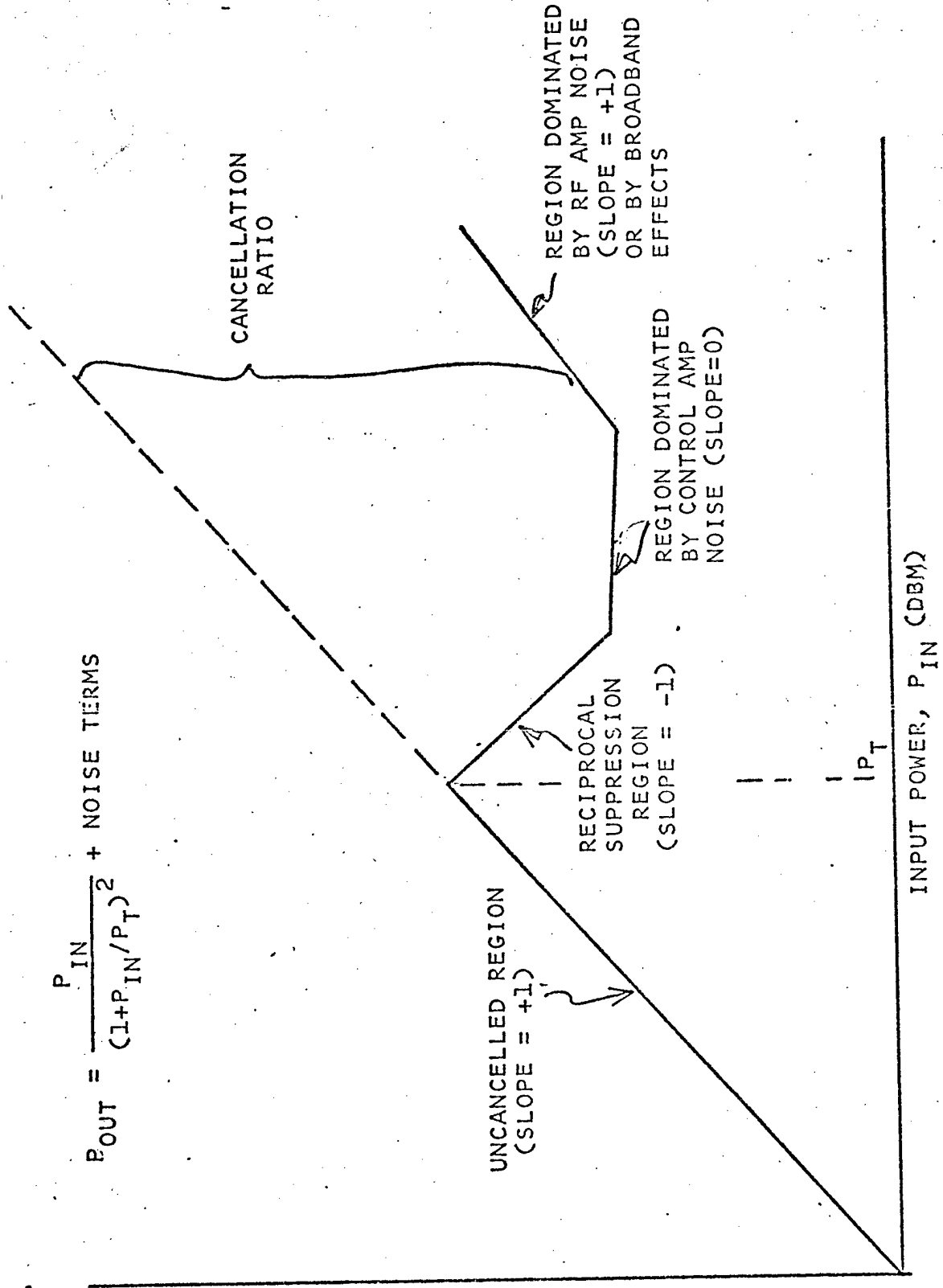

Although derived for a specific case, the N-curve represents an approximation to behavior under other conditions as well. If the loops contain perfect integrators instead of narrowband filters, then P_T is determined by the front end noise level [3]. If the adaptive array is overconstrained in that there are n incident jammers at varying power levels but there are only k degrees of freedom ($k < n$), then P_T is determined by the $(k + 1)$ -th strongest jammer. In multiple jammer scenarios, the N-curve approximates the nulling behavior of the adaptive array on each jammer individually in most cases. Data for 2 jammers is shown in Figure 5 and in [4].

1.5 Bandwidth Limitations on Null Depth - M effect

A broadband jammer may not be received simultaneously at all elements of an adaptive array, corresponding to different phase-vs-frequency slopes in the various array channel transfer functions. The complex weight attempts to compensate for these variations by a frequency-flat phase shift, which is correct at only one frequency and has ever increasing phase error as a function of offset from that frequency.

This limitation has been analyzed in [2] for a two element array. The assumed jammer power density spectrum is shown in Figure 6a, and the power density spectrum after nulling is shown in Figure 6b. Because of the spectral shape in Figure 6b, the null depth limitation is termed the "M effect". The ratio of power level in the output spectrum of Figure 6b to the power level in the spectrum of Figure 6a has been computed in [2] for endfire arrival on a two element array with interelement spacing d . These results are graphed in Figure 7.

FIGURE 5

NULLING PERFORMANCE OF A THREE-ELEMENT ADAPTIVE ARRAY

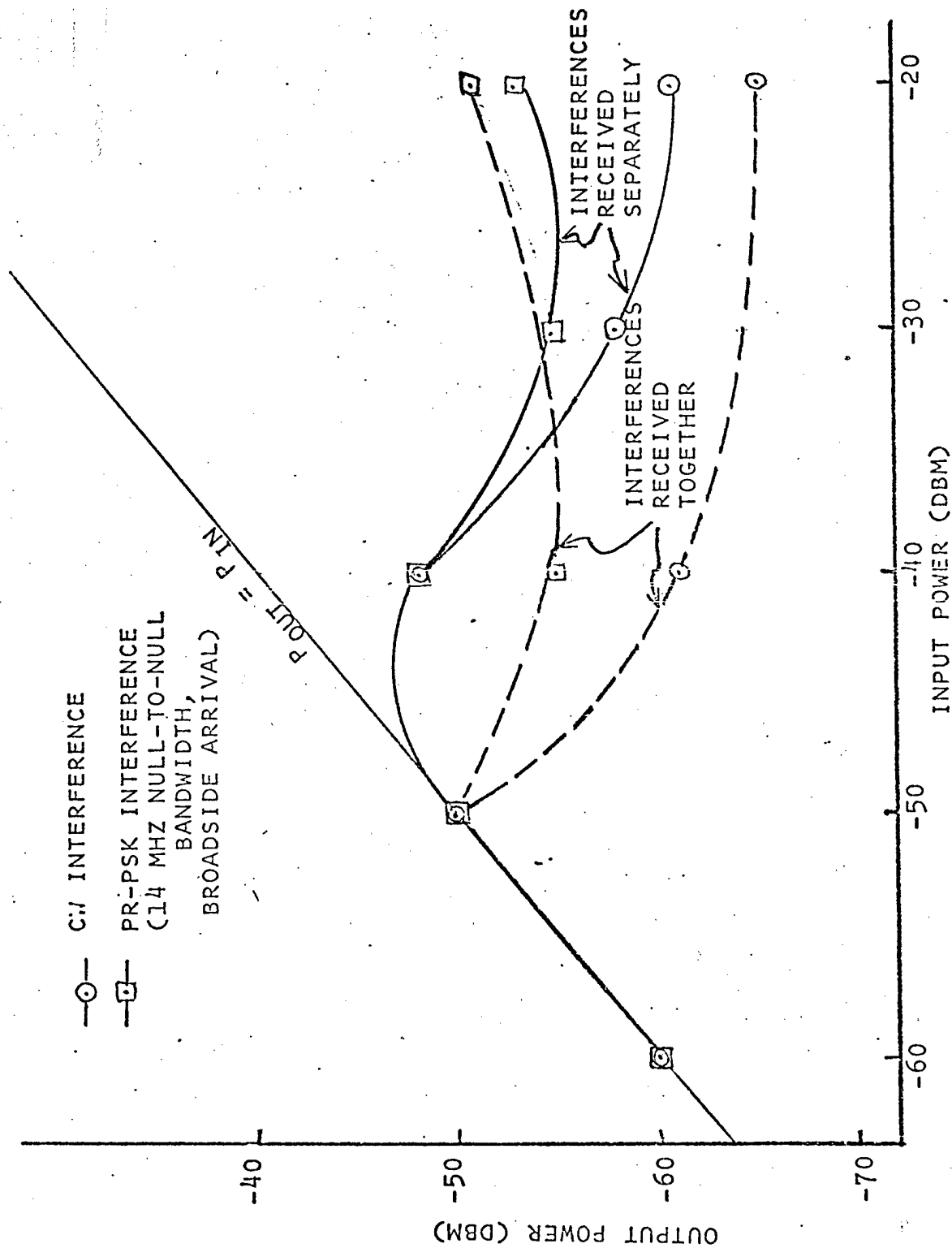

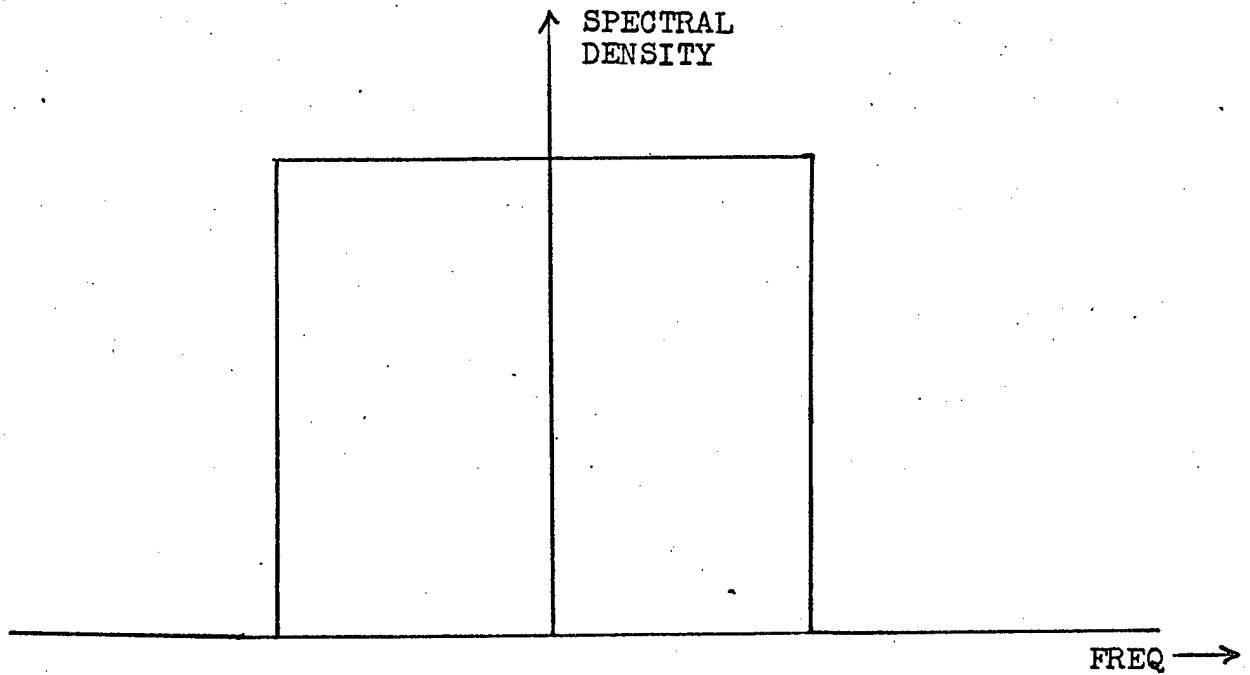

FIGURE 6a
BROADBAND JAMMER POWER SPECTRAL DENSITY

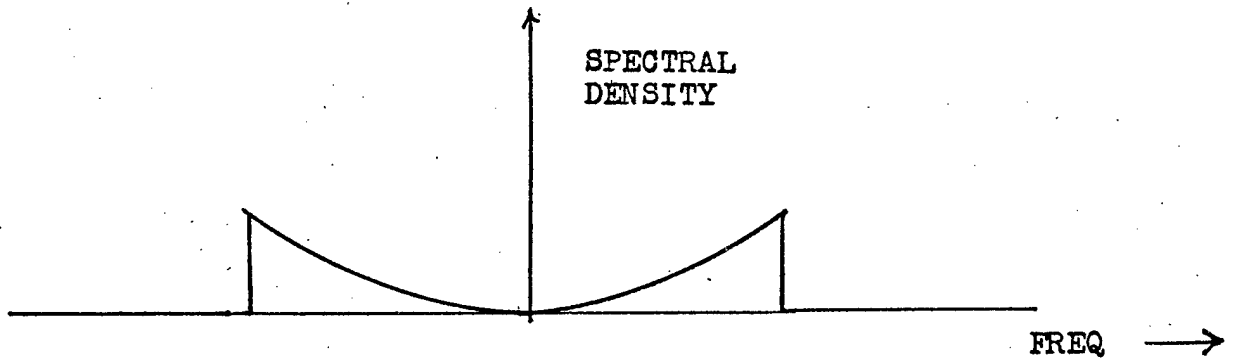

FIGURE 6b
POWER SPECTRAL DENSITY AFTER NULLING

FIGURE 7

ACHIEVABLE NULLING RATIO VS. JAMMER BANDWIDTH

MAIN ANTENNA AND ONE WEIGHTED ANTENNA
ENDFIRE ARRIVAL

$$NR = 2 \left[1 - \frac{\sin(\pi B d / c)}{\pi B d / c} \right]$$

d = ANTENNA SPACING

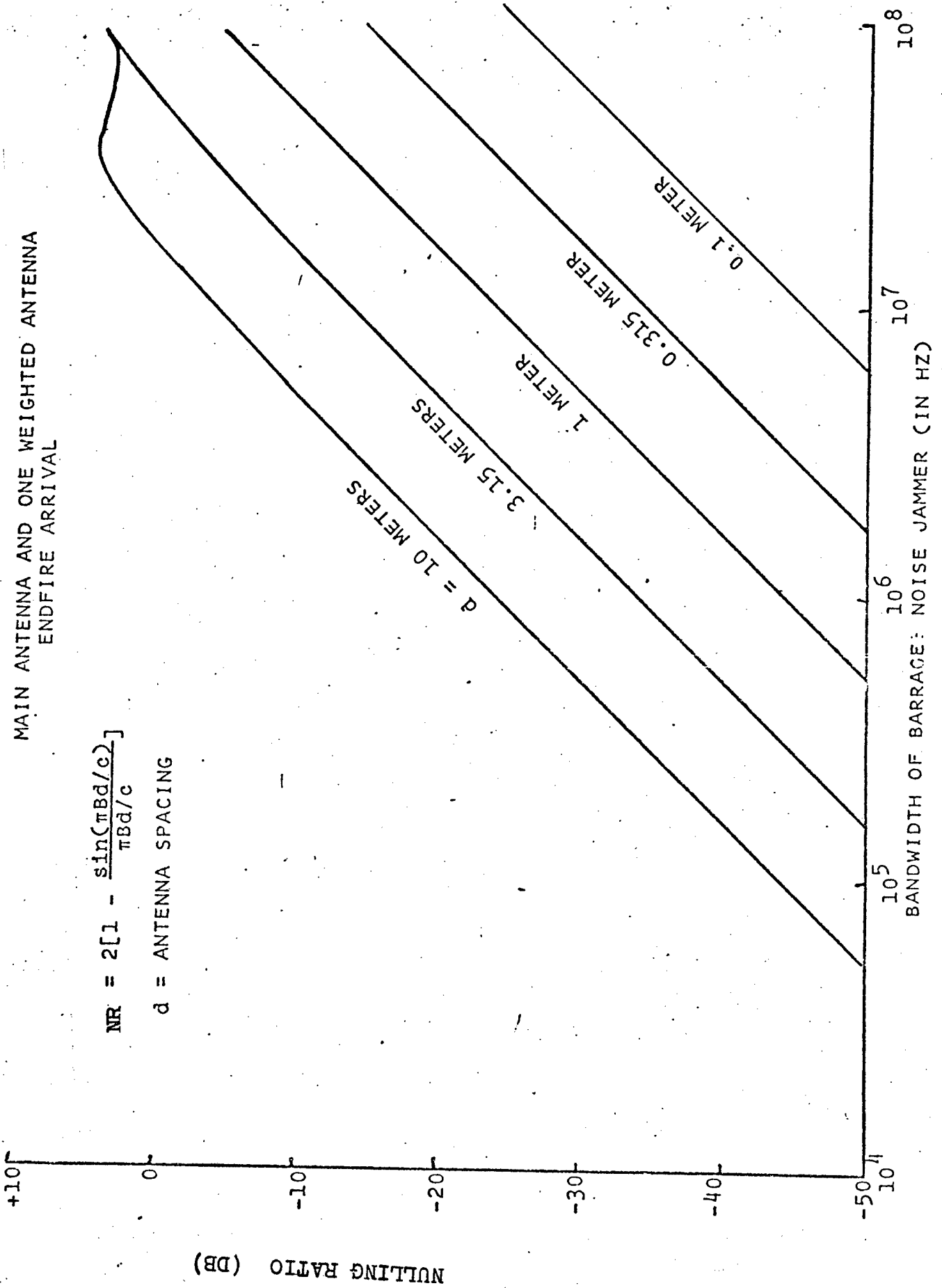

Broadband null depth can be maintained at the expense of hardware complexity if the array channels each pass through an equalizing network [5] , such as an adaptive tapped delay line equalizer on each element as described in [1] .

1.6 Noncancellation Regions with a Main Antenna Adaptive Array

The use of a desired signal reference in Figure 1 prevents the weights from seeking the all-zero solution by requiring that the desired signal be maintained at a fixed level. The main antenna system of Figure 2 also prevents the all zero solution, but it will null any jammer or signal above its threshold (see Section 4) within the capability of its degrees of freedom. It is most useful for desired signals whose received level is below the nulling threshold.

Another drawback of the main antenna adaptive array is pointed out in [2] in that there are certain jammer geometries for which nulling cannot be achieved even though the number of jammers equals the degrees of freedom of the array. This occurs because there is a linear dependence between the jammers as received at the weighted elements. As shown in [2] for the case of an array with two weighted elements and one unweighted, two jammers cannot be cancelled if the angle formed by the intersection of their propagation vectors is bisected by the line joining the two weighted elements. If the third element were weighted, nulling of the two jammers **would** be achieved by the third weight going to zero.

1.7 Acquisition Time

Because of the dependence of loop gain on jammer strength, and because of the dependence of the response time of a feedback loop on its loop gain, acquisition time depends on jammer strength. An analysis is done in [2] for a two element adaptive array (one element unweighted) of the jammer acquisition time (to within 3dB of the final value) as a function of jammer strength. The result is given here in Figure 8.

When **multiple** jammers are incident on an adaptive array, the stronger ones will in general be nulled fastest. However, Figure 8 does not apply strictly to each jammer individually because the system behavior to any one jammer is not independent of the others. This is most clearly seen by a system analysis in terms of its normal modes [6] in which the weight vector is transformed onto a set of orthogonal coordinates so that the input correlation matrix is diagonalized. The time constant associated with each mode is determined by its eigenvalue, which in turn is related to the jammer power levels and the geometry of their distribution with respect to the array element locations.

A trade-off of null depth vs. acquisition time is analyzed in [6] and [7]. Faster acquisition causes greater variance in the output error signal, about its mean value, which is reflected in the mean-square measurement of null depth.

1.8 Related Systems - The Radar Sidelobe Canceller (SLC) and The Interference Cancellation System (ICS)

The SLC and the ICS are closely related to the adaptive array in structure and function. This relationship is easily seen by com-

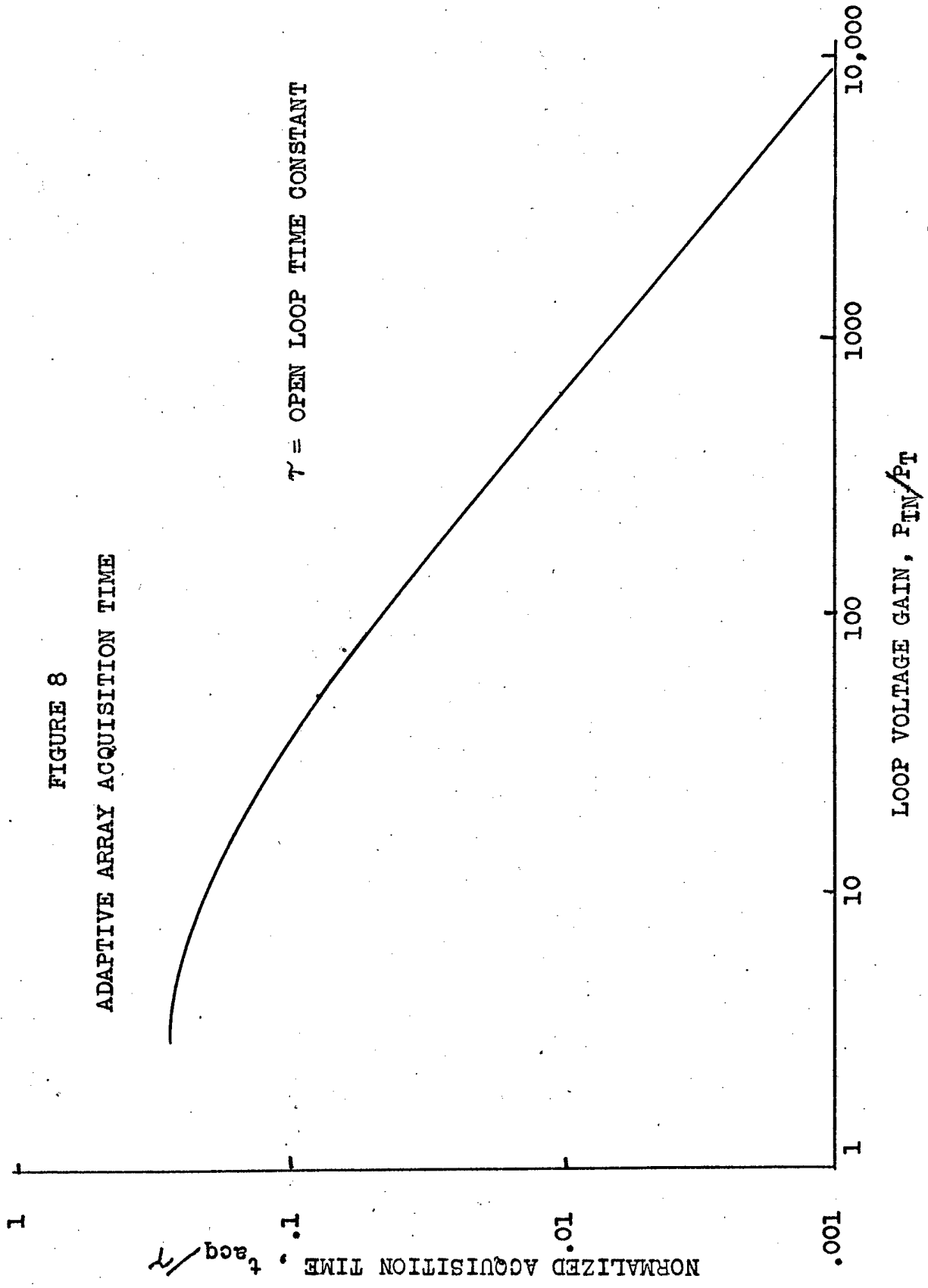

paring the block diagrams of Figures 1 and 2 to that for the SLC in Figure 9 and to that for the ICS in Figure 10.

1.9 A Spread Spectrum Adaptive Array

When an adaptive array is used in a spread spectrum system, the spread spectrum modem may be used to synthesize a desired signal reference to be used as in Figure 1. Such a system is described in [4]. A block diagram is shown in Figure 11. The SS modem is used to extract the desired signal from the residual jammers at the adaptive array output by stripping the PN code from it and filtering to the data bandwidth. The PN code is then restored and the resulting signal is hard-limited to hold its level fixed as a desired signal reference. Without the hard limiter, the weights could minimize the error signal by adopting the all zero solution, which cuts out reception of desired signal as well as jammers.

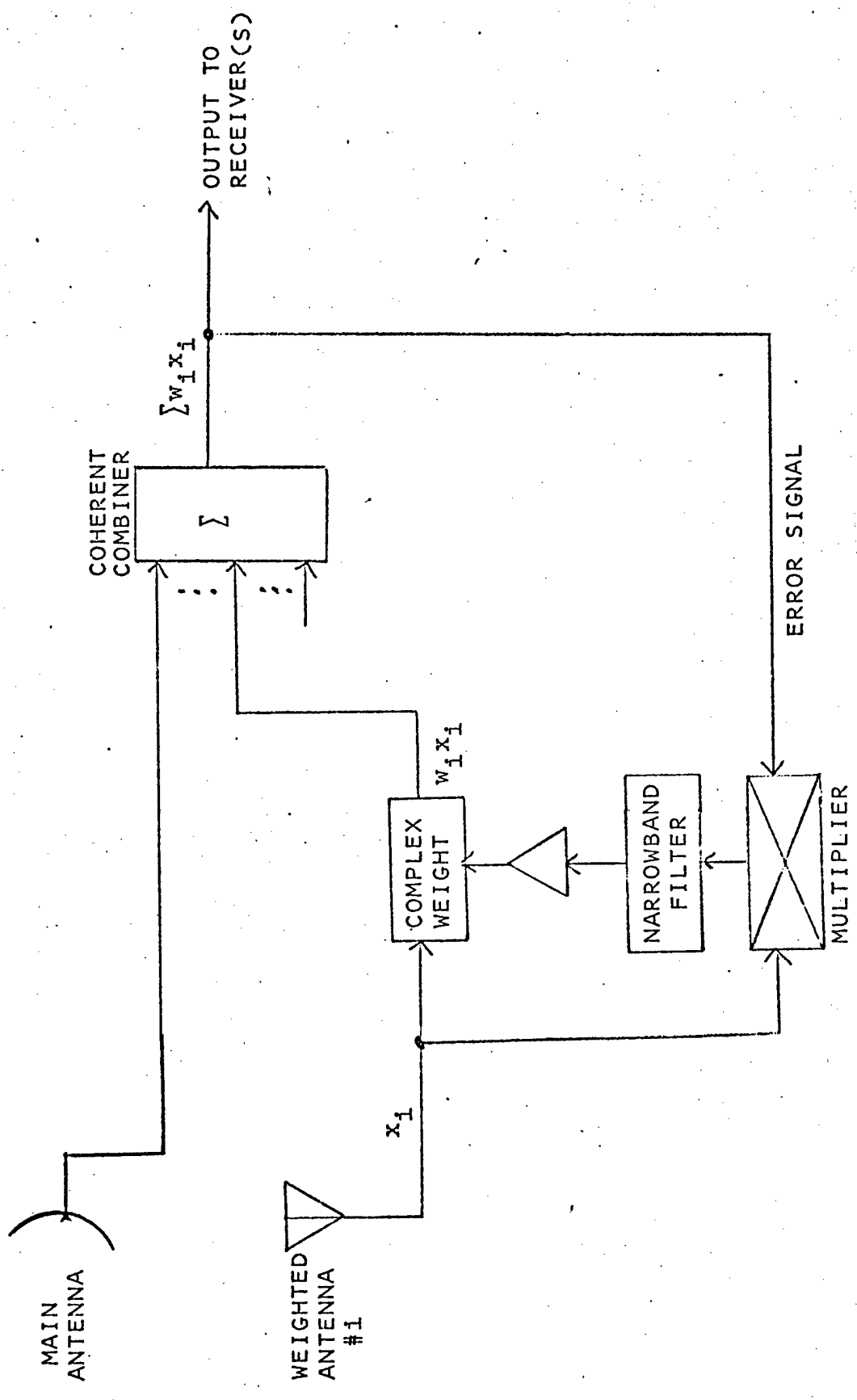

FIGURE 9
 SIDELOBE CANCELLER BLOCK DIAGRAM

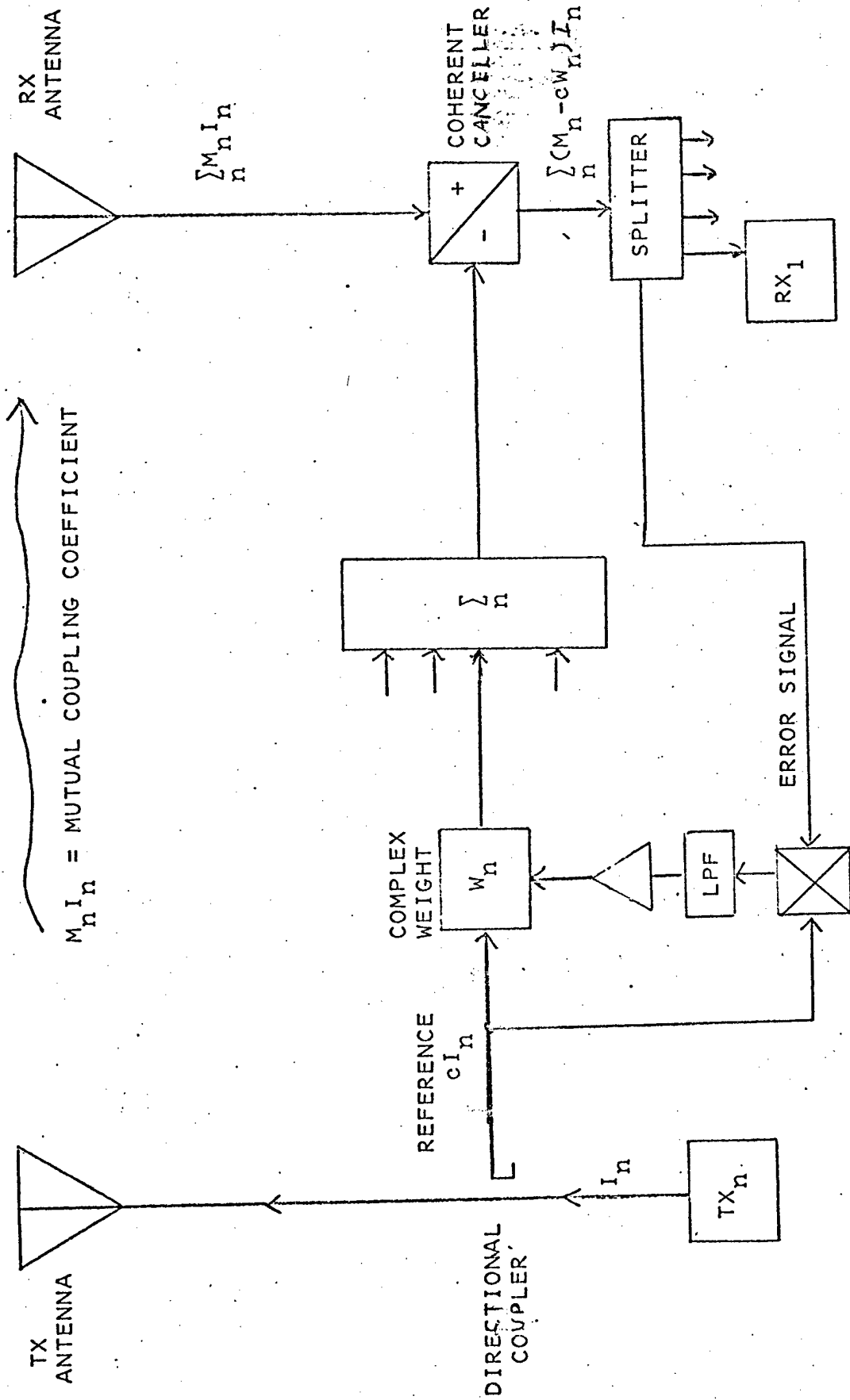

FIGURE 10
INTERFERENCE CANCELLATION SYSTEM BLOCK DIAGRAM

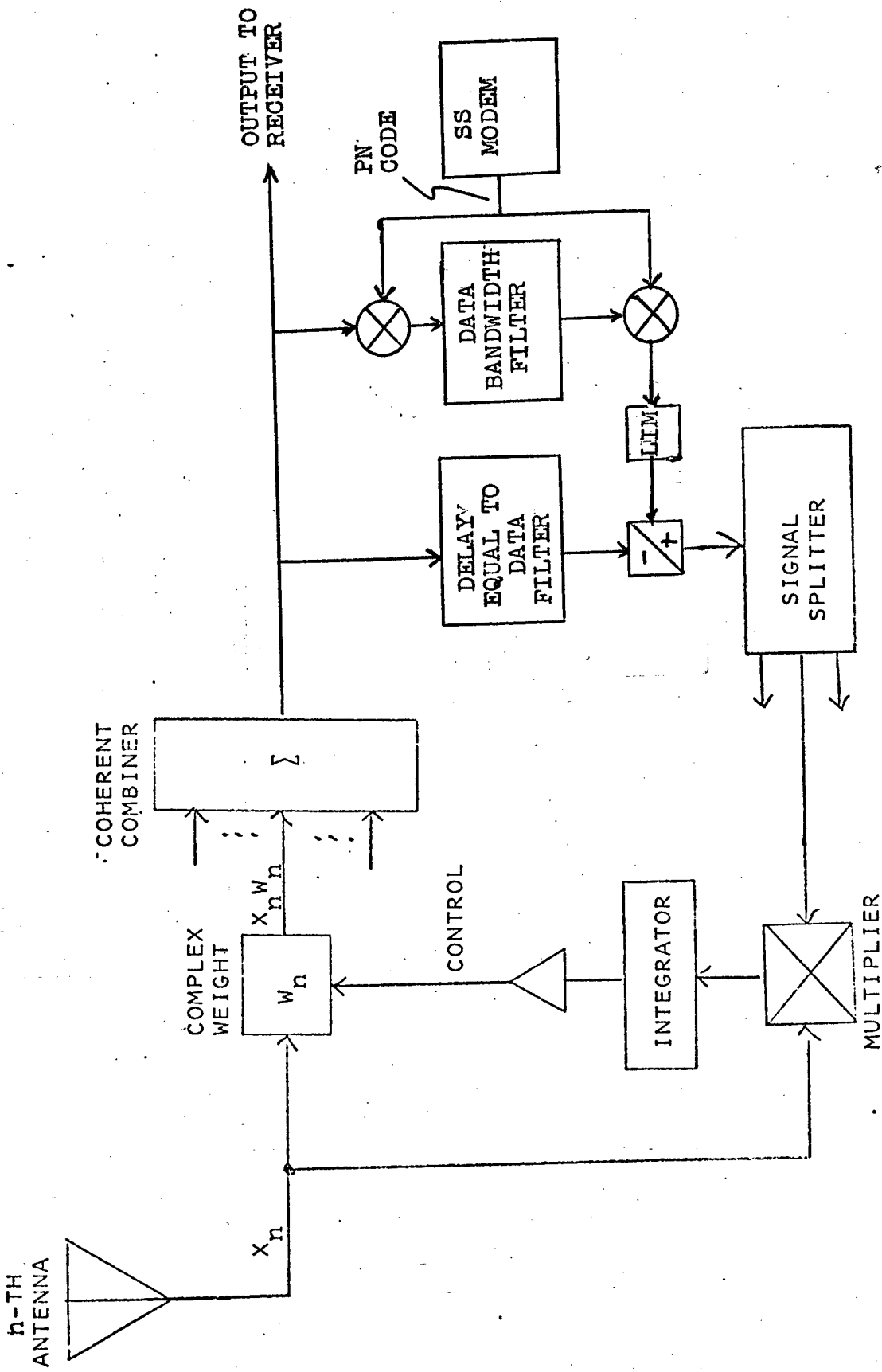

FIGURE 11
ADAPTIVE ARRAY FOR SPREAD SPECTRUM SYSTEMS

2.0 APPLICATIONS OF FAST ADAPTIVE ARRAY TECHNOLOGY

In this chapter we discuss three communications applications for an adaptive nulling antenna array having a very brief readaption

time: (a) Time Division Multiple Access (TDMA) Links

(b) Fast Frequency Hopped (FFH) Links

(c) Links afflicted with many impulse type interferences.

We first review the state of the art in rapidly adapting LMS arrays.

2.1 State of the Art in Fast Adaption

2.1.1 Achievements to Date

Adaptive array processors with adaption times in the micro-second range have been built. One such processor [2] was capable of nulling in 20 micro-seconds (operating at UHF), with its 1973 components.

Other high speed adaptive array work in which the authors participated was at L-band and was capable of nulling in 6 microseconds.

2.1.2 Hardware Limitations of Fast Adaption

The adjustment of the set of complex weights controls the antenna pattern formed by the array. If that pattern is to be capable of fast change, then obviously the complex weights must be capable of fast change.

A block diagram of a complex weight implemented in quadrature form (as opposed to amplitude and phase) was given in Figure 3. It contains two balanced modulators to separately adjust the in-phase (I) and quadrature (Q) weight components.

A number of techniques are available to implement the balanced modulators. One technique is to use a Schottky diode balanced mixer as a modulator. This technique produces an extremely fast complex weight, but it must be operated at relatively low power levels to prevent the generation of intermodulation products which effectively produce a floor on the null depth. High frequency transistors may be used in a balanced configuration with more resistance to intermodulation products and small sacrifice in the high speed control capability. PIN diodes may also be used in a balanced configuration, giving a full range of trade-off between intermodulation product generation and control speed as a function of the carrier lifetime associated with the diode type and the frequency at which it is used.

The weight control system must also be capable of a high speed response. In open loop weight control systems, such as a direct matrix inversion algorithm, a small throughput delay is required. In feedback control systems, such as the LMS algorithm and its derivatives, loop stability requires that the closed loop contain a single pole lowpass filter for its dominant pole, and all other poles must be at much higher frequencies. This requirement imposes design constraints on the filtering within the loop, as well as in the selection of operational amplifiers.

Circuit dynamic range in a feedback weight control system is also an important consideration. Adaption speed is sacrificed if saturation occurs in the weight control system before adaption when jammer nulls have not yet been established. If enough phase shift accompanies the saturation, adaption may never occur (unstable loops), even though for small signals the loops may be stable.

2.1.3 Theoretical Considerations of Fast Adaption

Fast adaption time necessitates the avoidance of narrow-band filtering in generating the weight control voltage. Since the control system is adaptive, the weight control voltages are derived from the signal and jammer scenario seen by the adaptive array. These waveforms are often noiselike in nature, so that the weight control voltages without heavy filtering will not be steady, but will contain some jitter components.

These effects have been analyzed for adaptive arrays with LMS control in [6] and [8]. The analysis in [6] shows that the mean square output of the adaptive array is equal to the ideal mean square output multiplied by the factor

$$1 + (g/4B\tau) \sum_{n=1}^N P_n \quad (2-1)$$

where $\sum_{n=1}^N P_n$ is the sum of the jammer input power levels

B is the jammer bandwidth at the adaptive processor input

τ is the time constant of the lowpass filter providing the weight control

g is a gain factor relating input power level to feedback loop gain (dimensions are inverse power).

As long as the second term in (2-1) is small compared to unity, then weight jitter will cause negligible deterioration in the adaptive array performance (that is, there is a negligible penalty for fast adaption time).

As an example, let us assume a single jammer whose loop gain is set at $gP=20$ (26dB), which will allow a null depth of 26dB. Results in [2, Fig. 17] show that the adaption time t_a is related to τ for $gP=20$ by

$$t_a / \tau = .1$$

If we require $t_a = 1$ microsecond, then $\tau = 10^{-5}$ seconds. If the input bandwidth B is 5MHz, then the value of the second term in (2-1) is computed to be 0.1. For this case there is a negligible penalty for fast adaption time.

2.1.4 Techniques to Improve Adaption Speed with LMS Control

In many cases for a fast frequency hopping system the signal and jammer scenario will change very little in the time interval between use of any particular hop frequency. Except for pulsed jammers, these changes will mainly be due to slight variations in received amplitudes and phases caused by flexure of the array support structure.

Storage of the last weight values used in each frequency bin then allows these values to be reinserted as the initial condition for the start of the adaption process. Since the new adapted weight values will usually not differ substantially from the old ones, adaption can be completed more rapidly.

Before adaption takes place the output level of the adaptive array processor is much higher than it is after adaption. This difference in level can be sensed and used to speed up adaption either by temporarily increasing the loop gain or temporarily decreasing the lowpass filter time constant to values which would cause degraded operation in steady state. After the output level has decreased to near the steady state level, the original time constant or loop gain is reassumed. A very simple implementation of this technique was used in [2].

2.2 Application of a Fast AA to TDMA

In many TDMA systems each user in the net must be capable of receiving signals sequentially from many users in different directions. To simplify this illustration suppose that each user transmits a distinct spread spectrum (SS) coded waveform. An adaptive array that uses the coded waveform to avoid nulling the user is illustrated in Figure 12. Ignore for the present reference to frequency hopping (FH) in the figure. At the AA output the code of the m -th user is employed to demodulate the SS code and to collapse the signals spectrum to its relatively narrow bandwidth. The signal passes through the narrow band pass filter (BPF) and is remodulated by its SS code to synthesize a signal reference for the AA feedback loop. The jammer waveforms have little or no correlation with the SS waveform and hence will have most of the wideband components of their product with the SS code well outside the narrow BPF. Thus, the AA error signal ϵ consists of two terms: uncanceled jammer terms; signal minus reference term. As the LMS loops drive ϵ^2 to zero the jammers are nulled at the array output and the desired signal is driven to the reference level at the limiter output. This acts as a gain constraint in the array pattern and prevents null formation in the direction of the m -th signal.

When the $(m+1)$ -th TDMA signal arrives the array must readapt so that its pattern will provide adequate gain toward the $(m+1)$ -th user. Readaption time must be short compared to the time that each user is allocated for transmission so that the beginning of each message is not lost. For example to assure a 99% message throughput in a TDMA

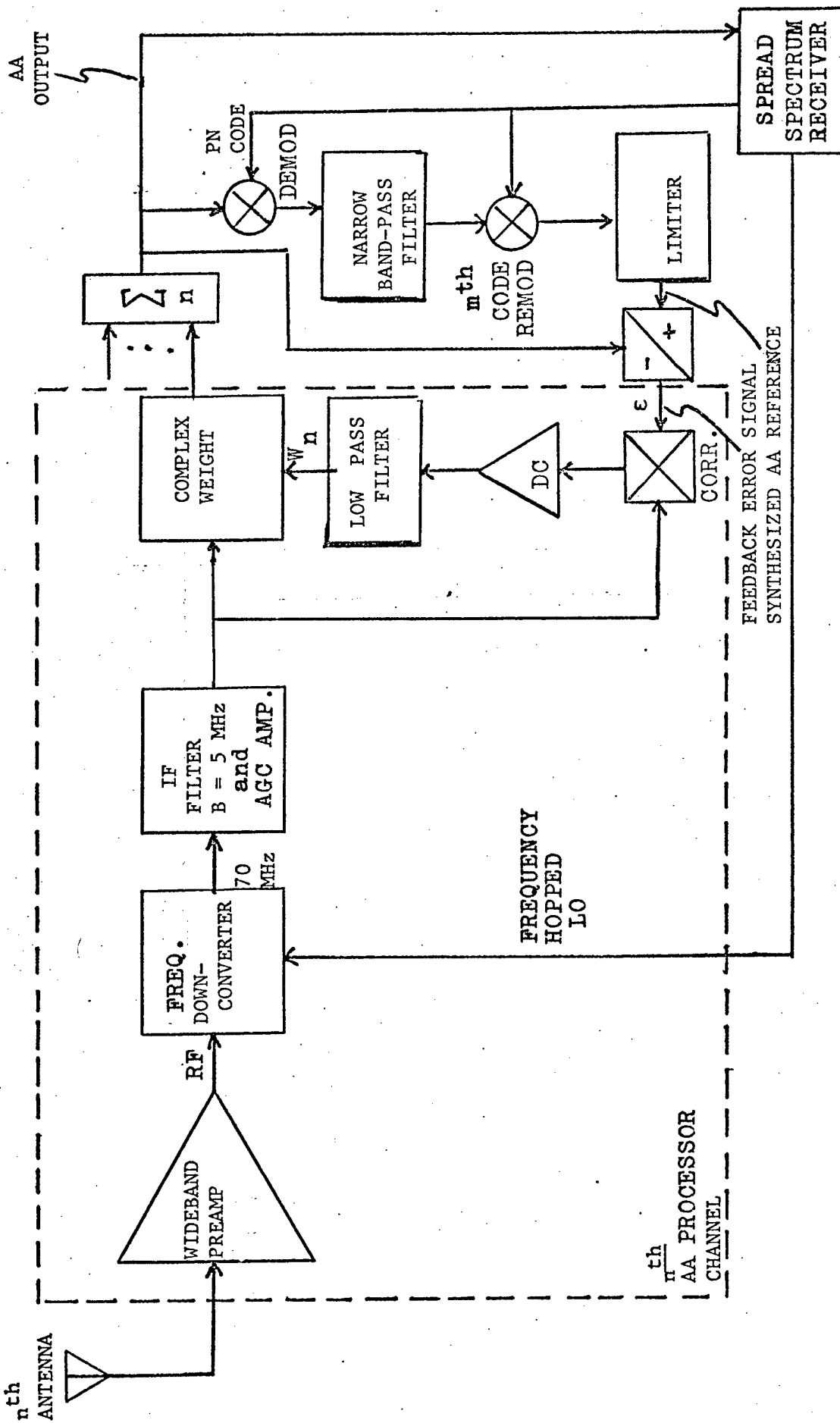

Figure 12
 FAST AA FOR FREQUENCY HOPPED TDMA COMMUNICATIONS

system which allocates 1 ms per user, the array must readapt within 10 μ sec.

We haven't addressed high speed null formation here because the interference scenario will often be the same as difference TDMA transmitters come on the air.

If there are not too many users in the TDMA net and if the net geometry only changes a little between consecutive times that the m -th user transmits, then the set of weight values $\{w_n\}$ could be stored away after each adaption on the m -th user. These same values would then be programmed into the complex weights just as the m -th user reappears to give the AA control system a "flying start" on readaption.

This approach to providing a reference which the AA output is forced to approximate with minimum mean square error has been established by analysis and testing of experimental models [4].

2.3 Fast Array Techniques for Frequency-Hopped Receivers

Frequency-hopped spread spectrum receivers are a special case of wideband receiver as far as the design of a complementary adaptive array is concerned. This is because the full bandwidth is not occupied instantaneously but on a frequency-hopped basis over time. At any instant of time the receiver bandwidth is the signal bandwidth about each individual hop frequency.

Such a receiver can be likened to a so called "narrowband" radio receiver that is pseudo-randomly tuned across a wide band of frequencies. It would be unwise to attempt to design an

adaptive array for an airborne UHF radio that provides AJ at all times across the 225-400 MHz band when only one 25kHz channel is in use at any time. A much more effective way is illustrated in Figure 13 where the signals from each antenna are frequency converted to a fixed IF for bandlimiting about the desired channel before adaptive array processing is applied. The nulling capability of the adaptive array is thus concentrated in the desired signal channel instead of being dispersed throughout the RF band or deteriorated by broadband null depth limitations.

The main distinction in the analogy between a frequency-hopped spread spectrum receiver and a tunable "narrowband" receiver is the hopping speed, which then imposes a requirement on the speed of null formation of the adaptive array processor. Each time a new frequency is used, the adaptive array processor must readapt itself to combat the new jammer scenario. For such an adaptive array to be effective it must be adapted in a time short compared to the hop dwell time.

The faster that an AA can adapt to a new frequency hop (FH) the faster the allowable FH rate and hence the more difficult for an enemy to construct a FH following jammer. The block diagram of an AA for a FH spread spectrum (SS) receiver is illustrated in Figure 12. where only the n -th antenna channel is shown. The wideband RF preamplifier establishes the system noise figure. The FH LO from the SS receiver converts the wideband FH signal from RF to a common IF (e.g., 70 MHz). An IF strip filters the reduced bandwidth signal to its psuedo-noise (PN) bandwidth

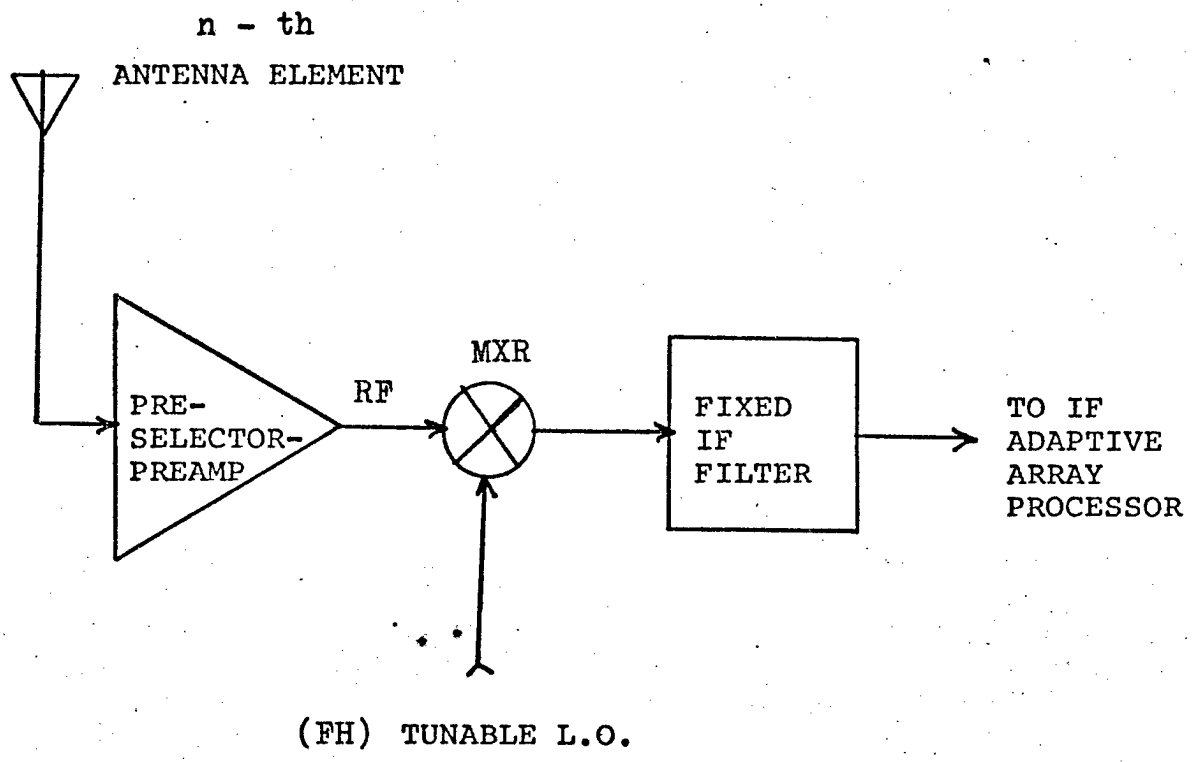

FIGURE 13

FRONT END FOR EACH ADAPTIVE ARRAY CHANNEL IN A TUNABLE (FH) RECEIVER

(e.g. 5 MHz) and an AGC adjusts the signal to a level which is suitable for the AA nulling threshold. The AGC must be as fast as the FH rate since jammers in "time-adjacent" frequency slots may be of different strengths. The rest of the AA in Figure 12 is a conventional LMS loop (discussed in Chapter 1) and a signal reference loop (discussed in section 2.2).

When the AA of Figure 12 is fast enough to readapt in a fraction of the time between hops the nulling bandwidth is 5MHz . Consider an interference that covers the entire FH band (e.g. 100 MHz). Suppose the band is located at 1 GHz and array elements are separated by $\lambda/2$ ($\lambda = 0.3$ meters).

In a conventional AA without dehopping and re-adaption the results of Chapter 1 show that the null depth on a 100 MHz wide interference at endfire would be less than 20dB. The fast AA would need only null that 5 MHz wide portion of the 100 MHz wide interference that lies in band at any instant and would be able to achieve up to a 46 dB null at endfire.

Against narrowband or spot interferences the fast FH AA offers a different advantage over a conventional AA. An N element AA can only form N-1 independent nulls at a time. Thus the fast AA can null up to N-1 distinct sources of interference in each 5MHz FH slot while the wide-open conventional AA can null N-1 interferences in the entire (100 MHz) FH band. In a severe interference environment the conventional broadband AA will rapidly exhaust its degrees of freedom.

The fast AA obviates many of the problems that beset wideband AA's for FH receives. The problems that plague wideband AA's include:

- (a) Multipath and other sources of time dispersion creating "new" jammers.
- (b) Delay dispersion across the array leading to the "M effect".
- (c) Circuit variations with frequency causing differential amplitude and phase vs. frequency variations from AA channel to channel, thus filling in nulls.
- (d) Hardware complexity as complex weights must be replaced by cumbersome tapped - delay line adaptive transversal filters [1] each having up to 64 LMS loops.

2.4 Fast AA For Nulling Numerous Impulse - Type Jammers

In this section we describe how a fast N element AA can have more than N-1 apparent degrees of freedom against impulse type jammers. It is shown how this fact greatly complicates an enemy ECM task.

2.4.1 Number of Jammers Nulled by a Fast AA

An N element array can only form N-1 independent nulls at one time and hence the AA can reject at most N-1 distinct jammers. Now consider a collection of K dispersed jammers each transmitting a short pulse of duration Δt with an average time T between pulses. If $K \geq N-1$ a conventional N element array will fail to protect a victim receiver. An N element array that can adapt in a time τ

that is short compared to the jammer pulse duration can effectively null all K jammers providing that pulses from no more than N-1 of the jammers arrive simultaneously at the array. This is not likely for many values of K and N since it is difficult and costly for the K dispersed jammers to synchronize their transmissions.

As an example, consider a N=2 element array and let K=2 jammers. Each jammer will independently transmit pulses having a duration $\Delta t = 250 \mu\text{sec}$. (e.g. matches to a 4 KHz UHF AM voice communication channel) at pseudo random times with an average interval $T = 5 \text{ ms}$ between pulses, (5% duty cycle). Such a jammer pair would greatly disrupt a radio protected by a conventional (slow) 2 element AA. A fast AA (adaption time $\leq 20 \mu\text{sec}$.) would sequentially null both jammers on a pulse by pulse basis and would only fail when pulses from both jammers arrived at the same time. For a 5% duty cycle jammer pulses would coincide only every 1/20th pulse or $(.05)^2 = .0025$ fraction of time. On an average power basis jammer power would be reduced by 20 to 1, (13 dB spacial AJ).

2.4.2 Are Impulse Jammers a Possible Threat?

With the deployment of AA's in the 1980's jammer strategies will have to change. A conventional (slow) AA will provide 20 dB to 40 dB additional AJ against jammers transmitting waveforms whose short term average power is constant with time (e.g. cw, swept FM, barrage noise). A jammer network can defeat an AA by using up the

AA's limited degrees of freedom. Thus four jammers are required to defeat a four element AA. But the jammer cost in hardware, fuel, personnel, etc., has increased four fold from the pre-AA days when a single jammer sufficed. Fuel could be saved by operating four jammers on a 25% duty cycle basis. Even more fuel could be saved by operating on a 5% basis thereby partially offsetting the acquisition and life cycle costs of the four jammers. Heat dissipation in a 5% duty cycle jammer is much less also which would lead to a less expensive circuit design. For these reasons impulse type jammers of low duty cycle are believed to be a reasonable enemy ECM strategy for the mid-1980's; at least until fast AA's replace slower AA's.

3.0 RECOMMENDATIONS FOR FAST AA DEVELOPMENT

Three applications of fast AA technology to ECCM were discussed in Chapter 2. Modern communications systems such as JTIDS-II, TIES, Packet Radio, SEEK TALK could increase their jam resistance by incorporating fast AA techniques. Additional development work is required to solve certain circuit difficulties with fast adaption LMS loops and additional analysis is required to better predict AA nulling performance against sophisticated jammer networks. Worth-while development tasks are listed below.

3.1 Multiple Impulse Jammer Network Analysis

The analysis of the performance of a 2 - element fast AA with a pair of pulse type jammers (section 2.3.1) should be extended to determine parametrically the average AJ (in dB) afforded by a fast N-element AA against K jammers where each jammer transmits a pulse of duration Δt every T seconds.

3.2 Breadboard Fast AA for FH Receiver

A simple one or two loop fast AA breadboard should be constructed and interfaced with a FH receiver (or simulated FH system) to verify its theoretical advantages. The use of a fast AA to aid spread spectrum modem acquisition in a severe ECM environment should be studied. Much can be learned by experimenting with such a breadboard and a variety of jammer types and deployments at relatively modest cost.

REFERENCES

1. B. Widrow, et al, "Adaptive Antenna Systems," Proc. of the IEEE, Vol. 55, No. 12, Dec. 1967, pp. 2143-2159.
2. B. S. Abrams, et al, "Interference Cancellation," General Atronics Corp. Final Report RADC-TR-74-225, Sept., 1974.
3. W. D. White, "Artificial Noise in Adaptive Arrays," IEEE Trans. on AES, Vol. AES-14, No. 2, March 1978, pp. 380-384.
4. R. T. Compton, Jr., "An Adaptive Array in a Spread Spectrum Communication System," Proc. of the IEEE, Vol. 66, No. 3, March 1978, pp 289-298.
5. M.J. DiToro, "Communication in Time-Frequency Spread Media Using Adaptive Equalization," Proc. of the IEEE, Vol. 56, Oct. 1968, pp. 1653-1679.
6. L. E. Brennan, E. L. Pugh, I. S. Reed, "Control Loop Noise in Adaptive Array Antennas," IEEE Trans on AES, Vol. AES-7, No. 2, March 1971, pp. 254-262.
7. B. Widrow and J. M. McCool, "A Comparison of Adaptive Algorithms Based on the Methods of Steepest Descent and Random Search," IEEE Trans. on Ant. and Prop., Vol. AP-24, No. 5, Sept. 1976, pp 615-637.
8. A. J. Berni, "Weight Jitter Phenamena in Adaptive Array Control Loops," IEEE Trans. on AES, Vol. AES - 13, No. 4, July 1977, pp. 355-361.

SECURITY CLASSIFICATION OF THIS PAGE (When Data Entered)

REPORT DOCUMENTATION PAGE		READ INSTRUCTIONS BEFORE COMPLETING FORM
1. REPORT NUMBER NADC-78061-30	2. GOVT ACCESSION NO.	3. RECIPIENT'S CATALOG NUMBER
4. TITLE (and Subtitle) INVESTIGATION OF FAST ADAPTIVE ARRAY TECHNIQUES FOR ADVANCED COMMUNICATION SYSTEMS.		5. TYPE OF REPORT & PERIOD COVERED Final Report 4/11/78 to 11/11/78
		6. PERFORMING ORG. REPORT NUMBER NADC-78061-30
7. AUTHOR(s) Andrew E. Zeger Burton S. Abrams		8. CONTRACT OR GRANT NUMBER(s) N62269-78-M-6902
9. PERFORMING ORGANIZATION NAME AND ADDRESS Zeger-Abrams Incorporated 1112 Clark Road Philadelphia, Pa. 19118		10. PROGRAM ELEMENT, PROJECT, TASK AREA & WORK UNIT NUMBERS 400X3ABM
11. CONTROLLING OFFICE NAME AND ADDRESS U. S. Naval Air Development Center Warminster, Pa. 18974		12. REPORT DATE November 11, 1978
		13. NUMBER OF PAGES 32
14. MONITORING AGENCY NAME & ADDRESS (If different from Controlling Office)		15. SECURITY CLASS. (of this report) Unclassified
		15a. DECLASSIFICATION/DOWNGRADING SCHEDULE
16. DISTRIBUTION STATEMENT (of this Report) Unlimited		
17. DISTRIBUTION STATEMENT (of the abstract entered in Block 20, if different from Report)		
18. SUPPLEMENTARY NOTES		
19. KEY WORDS (Continue on reverse side if necessary and identify by block number) Adaptive Antenna Nulling Array TDMA Communications Interference Cancellation System		
20. ABSTRACT (Continue on reverse side if necessary and identify by block number) The important characteristics of an adaptive array (AA) employing the least mean square (LMS) control algorithm are quantitatively discussed. It is shown that a fast AA, one requiring a very short time to form pattern nulls, greatly improves the resistance of a TDMA communications system to directional sources of interference. An N-element fast AA		