

JPRS-JST-91-034
22 NOVEMBER 1991



JPRS Report

Science & Technology

Japan

19990112 119

Reproduced From
Best Available Copy

DTIC QUALITY INSPECTED 3

REPRODUCED BY
U.S. DEPARTMENT OF COMMERCE
NATIONAL TECHNICAL
INFORMATION SERVICE
SPRINGFIELD, VA 22161

Science & Technology Japan

JPRS-JST-91-034

CONTENTS

22 November 1991

Science & Technology Policy/Competitiveness Issues

- Proposal on Reforms in Science Education & Research for Promotion of Basic Science
[KISO KAGAKU SHINKO NO TAME NO RIGAKU KYOIKU/KENKYU NO ARIKATA, Mar 91] 1
- Summary of the First Symposium on Intelligent Materials
[Shoki Watanabe; PROMETHEUS May-June 91 pp 54-55] 10
- Summary of the 12th Functionally Gradient Materials Forum Workshop
[PROMETHEUS, May-June 91] 12
- Komatsu Chairman on Company's European Strategy
[A. Gandow; Duesseldorf HANDELSBLATT, 19 Aug 91] 14

Advanced Materials

- Development Trends in Functionally Gradient Metals
[Kenji Wakashima, Tohru Hirano, et al.; SPECIAL LECTURE SERIES: OUTLOOK FOR JAPANESE
TECHNOLOGY IN THE 21ST CENTURY, Nov 90] 16

Computers

- Japan: Toshiba Coporation Introduces New 1-Megabit SRAM Chips [KYODO, 6 Nov 91] 25

Energy

- Fuel Cell Power Plant Near Commercialization [Waku Yamagiwa; TSUSAN JANARU, May 91] 26
- MITI To Increase Electric Power by 5,000MW in Next Two Years
[GENSHIRYOKU SANGYO SHIMBUN, 2 May 91] 29

Factory Automation

- Intelligent Manufacturing System (IMS)
[Hitoyuki Yoshikawa; BULLETIN OF THE INSTITUTE OF PRECISION ENGINEERS, Vol 57 No 1,
1991] 30

Nuclear Engineering

- Atomic Energy Commission's Report on Fuel Recycling, Plutonium LWR
[GENSHIRYOKU SANGYO SHIMBUN, 8 Aug 91] 36

Proposal on Reforms in Science Education & Research for Promotion of Basic Science

916C3807A Tokyo KISO KAGAKU SHINKO NO
TAME NO RIGAKU KYOIKU/KENKYU NO
ARIKATA in Japanese Mar 91 pp 1-22

[Report by the deans of science faculties of 10 universities]

[Text]

Circumstances That Led to the Conference

There has been a lot of criticism about the present state of university science education in Japan. That and the increasing worries about the future has prompted Suwa (Nagoya University), Wada (University of Tokyo), Kawakubo (Tokyo Institute of Technology), and Matsuda (Kyushu University), then deans of science faculties in their respective universities, to hold conferences to discuss reforms in science education and research for the promotion of basic science. The outcome of the conference is a report which will play a major role in the promotion of the basic sciences by the Ministry of Education and will provide invaluable suggestions to the budgeting department for making the right decisions. A council spearheaded by Wada, dean of the Science Department, University of Tokyo, and deans of science faculties in 10 universities was created to look into the problems and best possible methods for nurturing human resources for teaching and conducting world level science research. Measures to meet both international and domestic demands must be developed. The first conference was held on 24 March 1990 and up to February 1991, a total of five conferences were arranged on the dates shown below. These conferences were attended by the deans and other councillors. During the course of the discussions, most were of the opinion that science education and research cannot be separated and as such, discussions were focused on science research. Hence the title.

1st conference	24 March 1990	Tokyo
2nd conference	21 April 1990	Tokyo (Ministry of Education)
3rd conference	1 June 1990	Kyoto
4th conference	25 October 1990	Tokyo
5th conference	16 February 1991	Tokyo (University of Tokyo)

(Grassroots members convened at University of Tokyo on 1 October 1990.)

Council Members

Dean of Science Dept., Hokkaido Univ.	Yu Hariya
Councillor, Hokkaido Univ.	Hiroshi Hori
Dean of Science Dept., Tohoku Univ.	Tadasahi Kuroda (Until 31 March 1990)

Dean of Science Dept., Tohoku Univ.	Hideki Sakurai (From 1 April 1990)
Councillor, Tohoku Univ.	Kenichiro Aoki
Dean of Natural Science Dept., Tsukuba Univ.	Yoshiro Nakagawa
Section Head of Biological Science, Tsukuba Univ.	Tatsuaki Shibuya
Dean of Science Dept., Tokyo Inst. of Tech.	Tatsuyuki Kawakubo
Dean of Science Dept., Tokyo Univ.	Akimitsu Wada (Until 31 March 1990)
Dean of Science Dept., Tokyo Univ.	Ikuo Kujo (From 1 April 1990)
Councillor, Tokyo Univ.	Masuo Suzuki
Dean of Science Dept., Nagoya Univ.	K. Suwa (Until 31 December 1990)
Dean of Science Dept., Nagoya Univ.	Masaru Yasuno (From 1 January 1991)
Dean of Science Dept., Osaka Univ.	Junjiro Kanamori
Professor of Osaka Univ.	Nobuyuki Ikeda
Dean of Science Dept., Kyoto Univ.	Toshitaka Hidaka
Councillor, Kyoto Univ.	Kazuhiro Maruyama
Dean of Science Dept., Hiroshima Univ.	Masahiro Sugawara
Dean of Science Dept., Kyushu Univ.	Hirotsugu Matsuda (Until 15 July 1990)
Dean of Science Dept., Kyushu Univ.	Yoshimasa Takashima (From 16 July 1991)

Prologue

Science and technology will be taking great leaps in the future and the world will be looking for contributions from Japan to advancements in technology and the natural sciences which form the basis of technology and helps create an intelligent human culture. Consequently, there is an urgent need for the promotion of advances in the natural sciences. Advances in natural sciences should be thought of in terms of a "National 100 years project" but short term measures to realize that should also be considered. The most important factor in the promotion of the natural sciences is personnel training, or in other words, science education. Most of this responsibility lies with the university science departments and the related graduate schools. Chapter I describes the type of science education in science departments and graduate schools for the promotion of the natural sciences. Chapter II lists various opinions on scientific research while Chapter III touches on the problems in science education and research and proposals for their countermeasures. These proposals not only represent the expectations on the related governmental body but are also the basis for self-development of university science departments and their staffs.

I. Science Education

Universities have completely changed since the half century after World War II. In the past, "university

students should not be spoon fed, and only those who study on their own accord need be considered for a university education" was the common opinion. Those were the days when the small handful of science students stood aloof from the rest of the world and did not bother themselves with social issues. However, the nearly 4,000 graduates pouring out annually from the national and private universities throughout the nation who continue on to graduate schools and finally end up in various positions with companies, clearly indicates that this belief no longer holds true. When then is the reason for the existence of the science department at this point in time? What should science education be like? First of all, these ideals should be reconfirmed.

The first purpose of science education is the pursuit of nature's truth and through the creation of an intelligent culture, help nurture the proper kind of people who can contribute to the advancement of mankind. At the same time, there will be great expectations in the development of staffs who can contribute to advancements in industrial technology as well as science and technology based on new ideologies developed from present science education. It will not be enough for the researcher or the engineer to be able to simply apply existing principles to technology for development but they will have to be able to stake out new phenomena, establish the problematic areas, understand the principles behind them and then apply them. In short, they will have to be trained to cultivate an interest in a wide number of areas. Although Japan is a world leader in many industrial technology fields, it is not a star pupil when it comes to the creation of new technologies from the principles. We believe that now is the proper time for Japan to recognize the importance of science education in the alteration of the nature of Japanese industrial technology that is said to be advanced but whose foundation is nevertheless a little weak. The science education described here would be one that will nurture people who have the following characteristics:

(1) A very curious person. (2) A person who can ascertain the nature of a phenomenon and thoroughly pursues the principles behind it. (3) A person who can conduct endless observations and experiments. (4) A person with interests in other fields and can actively pursue unnatural circumstances. (5) A creative person who can churn out revolutionary ideas by combining all the knowledge gained and developing them a step further. (6) A person who has superior abilities in developing theories from these ideas. (7) A person who can develop models from a phenomenon and has the ability to convince others of the phenomenon both theoretically and sensibly.

It is difficult for one person to be born with all the above-mentioned characteristics but science education can help train them in some of the characteristics. It is also important that different people with different combinations of characteristics coexist and interact with each other. The creation of such environments will be one of the main themes for science education.

The present situation in Japan is that not many people with the above-mentioned characteristics have been trained. In fact, the common belief is that these kinds of people are decreasing. In view of this, the following considerations must be made before an ideal science educational system can be created.

(1) It must be clearly understood that there is a lot of waste in the current educational system. If this is removed in order to create a more effective system, narrow-minded and unprincipled people would result thereby greatly reducing the investment returns. The waste and purposelessness in the educational system should not be eliminated. Even if the investment seems a waste, a superior person will be able to glean something from such situations and finally come out to be stronger when considered from all aspects. Consequently, the system is not a waste when the final results are considered.

(2) There are many problems in the entrance examinations system today. Those allowed into the science departments by the uniform examinations conducted by the Entrance Examination Center are not necessarily appropriate. This is because the students are not subjectively examined but instead are checked on how fast they can reach a predetermined answer. There is also a strong tendency for students to be trained in such examinations. Further, the same type of students tend to be admitted into one university when the same uniform examination is widely applied. This point opposes the above-mentioned ideal that it is important for people with different characteristics to coexist. Each university must seriously consider the possibilities of improving the fundamentals of the entrance examination system including the examinations set by the Entrance Examination Center. We must also be prepared for a yet bigger responsibility when implementing the improvements.

(3) The basic academic level of a student when sitting for the university entrance examinations is comparable to that in America and European countries. In fact, the level in basic fundamentals is far superior. However, differences in the academic levels in both countries disappear and sometimes the Japanese student's level becomes much more inferior by the time the student graduates from university. One reason is the present education policy in universities but the main reason lies in the difference in attitudes of the university students and the amount of studies they put in. It is not necessary for university students to study excessively but it is necessary for them to put in a certain amount of time and effort in studies that are not for passing examinations but rather for grasping the nature of phenomena and cultivating logical thinking.

(4) Free expression by the students should be respected. In particular, research results or ways of thinking which differ completely from conventional and existing values should be given proper evaluation (including degrees). The best system would be one where the students can

concentrate on subjects they like thereby helping them to develop their creative powers and respecting their individualities.

(5) It is generally believed that professors in Japanese universities feel less responsible toward education when compared to their American counterparts. Some Japanese professors even think of their classes as a side job and as such, these attitudes have to be altered. However, it goes without saying that these changes have to be self-induced and not forced.

(6) Students must be trained in logical thinking and basic academic knowledge. They should also be trained to discover problems themselves.

(7) Science department professors now give more lectures at lower university grades. Professors should not only talk on the fundamentals but should also touch on their research (for instance, experiences gained during research). Students should not only be taught the established facts but should also be told the unknowns and un-understandables in other fields.

(8) Students should also be trained in presentations. Japanese students and researchers are usually not given enough training in this art. No matter how important or sensational the results of a research project is, the impact is negligible if its presentation or expression is poor. Students must always remember that when presenting the results of their research, they should use clear and simple explanations. Students should be continually trained in this art.

(9) Besides university education, both elementary and secondary education should be reconsidered before students with the above-mentioned characteristics can be nurtured and creative research developed in numbers. If the current existing uniform elementary and secondary education continues, students who think and behave like each other will be created and they will not be able to have creative thoughts when they become adults as a result of trained reflexes. American and European children are taught to be individualistic and are not evaluated if they do not talk or think uniquely. In the future Japan should attach more importance to creativity and for that reason, elementary, secondary and university students should be encouraged and trained to have their own creative thoughts and those around them should respect these thoughts and opinions.

II. Science Research

The structure of scientific research should be reconfirmed for the promotion of basic sciences and Japan's greater contributions in the future. The following should be considered when creating the ideal science research system. (1) Aim for the establishment of new principles and theories. The more basic the theory or principle is, the greater the impact it will give. (2) Research should be long term projects with deep insights. (3) Research

should have interesting stories behind them. These stories will help alter the way we think about or understand a certain phenomenon.

The fundamental role of science is the presentation of such basic and yet revolutionary ways of thinking and understanding of phenomenon. These scientific opinions will affect ways of thinking in technology, agriculture and sometimes even philosophy or world issues and social issues. This is exactly what was meant when the aforementioned ideology that the fundamental value of science research is not only for the technology fundamentals but also for the creation of culture.

The following are some of the problems faced by existing scientific research in Japan.

(1) There is an extremely small number of research projects that will help change the present trend in the academic field. In other words, original research projects are few. Also, there are very few research projects which have interesting stories or even great stories behind them. In Japan, a lot of work is involved in burying these stories.

(2) There is too much research that attaches a lot of importance to secondary data or information (for instance, computer processed data). The recent trend is to attach less importance to primary data like the observation of natural occurrences or experiments (this trend is especially prominent in young researchers).

(3) Most research is so-called "popular" or "trendy" and one of the reasons is the low budget assigned for the research. Research that gives immediate short term results tends to get the budget approved easier. If this trend continues, scientific research will become distorted. The fundamental values of such research are not being understood at all and while meaningless words like the "pursuit of truth" are used, researchers do question the importance of their work. Under these present circumstances, it is questionable whether the research is being appropriately assessed and it is difficult to say that sufficient budget has been assigned to truly superior scientific research.

(4) Most research and educational facilities have deteriorated and are in a poor state of repair. Research and education budgets are extremely meager. This utterly realistic problem will be further explained under "Actual Problems."

(5) Supportive systems for research and education are on the verge of destruction with administrators or technicians being laid off. As a result, professors will spend less and less time on education and research. Most professors are not suited for such work and as such will finally end up having most of their time and efforts wasted. The side duties will become a burden to their research. This is a great waste and loss from the point of education and research.

(6) In the past few years when a new department or section was established, staffs could not be newly recruited but instead were transferred from other departments. As a result, incomplete departments with inappropriate staffs were created and this in turn significantly affected education and research.

The following must be considered before the aforementioned problems can be solved.

(1) The fundamental attitude and consciousness of researchers (especially young researchers when the future is considered) has to be revolutionized. The young researchers should not perform "fashionable" research work but instead should continue pursuing his/her work. People around the researcher should understand and provide support even when, for instance, no results are obtained.

(2) Investments in research which appear wasteful at first glance should also be given due consideration. Investment for the sake of profit-making should be eliminated.

(3) University administrative and management systems should be improved to allow the teaching staffs (especially the young and leading researchers) more time for their own research work and not pressure them into other duties.

(4) An appropriate budget is necessary for developing superior research work and researchers. As such, the establishment of a system to properly assess the value of a research project and ascertain its priority would be of utmost importance.

(5) Basic science research work on an international basis as well as in work which is not clearly defined under one academic category should be encouraged. Programs which apply the advantages of a university must be established to achieve this type of research.

(6) Facilities and equipment must be immediately improved. We must change our attitudes and recognize the importance of investments for the sake of pursuing top world level research.

(7) Education and research support staffs like technicians and administrators must be increased to enable smooth performance of research.

(8) The graduate student system should be improved and PDF system should be considered.

(9) Exchanges between university teaching staffs and between the research done by university graduate students should be more active.

Items (6)-(9) will be further discussed in the next chapter.

III. Actual Problems

In Chapters I and II, we described the ideals of science education and research and further touched on Japan's present situation and its problems. In this chapter, we will touch on the problems involved when implementing

the type of science education and research described in the previous chapters and then we will propose some concrete countermeasures to solve them.

1. Improvements in the Graduate Student System

Most science graduates, in particular, those in the doctorate courses are involved in research work at the frontline and to most universities, they are the most important staffs. Despite that, these graduate students are not given the proper treatment that matches their positions. In particular, their research budgets are usually not given consideration and it is not an uncommon thing for most of their work to be paid through the professor's expenses account. In this manner, graduate students are prevented from doing the type of research they want. Further, space for graduate students is not being considered at all. Graduate students must be provided with the proper environment before they can create revolutionary research ideas. The following are some of our proposals.

(1) University graduate students should be considered research assistants and the proper budget should be assigned for them. Applications for research grants should be considered. In this case, these grants should be considered under a different basis.

(2) Graduate students will be given privileged treatment since, by becoming teaching assistants, they will be given research grants and they will be able to expand their horizons and experiences through teaching. Some universities (Tohoku University, Tokyo Institute of Technology, University of Tokyo, Nagoya University, Kyushu University) have already implemented this system but it should be systemized to cover all universities. A separate budget should be assigned.

(3) Scholarships for graduate students should be changed to a partial salary system. In other words, the current scholarship program for doctorate students should be completely changed such that all doctorate students should be given a salary (for example, 50% of the scholarship). In the past few years, the Japan Society for the Promotion of Science has expanded its "Special Researchers" budget for doctorate students and improvements are gradually being made but this is still very insignificant.

(4) Space per graduate student should be considered when calculating the standard surface area required for research. For example, the area for graduate students can be calculated from the actual number of graduate students in the past and then added to the standard surface area.

2. Assistants

Most assistants in universities already have their degrees and are an important asset in research education. Despite this, assistants do not necessarily have the best end of the bargain. Most university assistants take up the position immediately before or after they complete their

doctorate course. This is also an important time for them to further develop their research work. In spite of that, assistants are usually given other duties so much so that they are left with no time for their own work. Add that to a poor research budget and inefficient chair system, and it will not be an uncommon thing for the assistant to almost abandon his/her own work. In America and other countries, after getting their degrees, most graduate students either become assistant professors who can independently pursue their work in education and research or they continue doing only research work as PDs. It is also very common for the people around them to give these young researchers their full support. The assistant in Japan is given life-time employment while in America, the assistant professor is not. The American assistant professor is involved in research and education only until he/she completes his/her tenure. No matter what the reason, it is very clear that a great difference will appear in future between one researcher who is fully occupied with side duties and one who can pledge all his/her time for research.

This is a major problem and some form of remedial measures are required. One of the reasons for the many side duties of the Japanese assistant and the strict budget lies probably with the rigid chair system. The shortcomings in the chair system, at least within the science department should be reduced such that young researchers are allowed to do their own work.

Improvements in the system should also be made. Assistants with degrees should be made lecturers but it would be impossible to implement that immediately. As a prior measure, these assistants can be made lecturers in charge of graduate students. For that, the following clause should be added to Articles 8 and 9 of the Graduate School Accreditation Standard. "Assistants with doctorate qualifications (those with doctorate degrees) can be included as a member of the graduate school teaching staff in the position of a graduate school lecturer." Once this is implemented, graduate school education can be improved and assistants can achieve a more independent status as a member of the teaching staff. However, this is merely a temporary measure and fundamental improvements must be made for long term results.

3. Chair System

The chair system was established in 1893 to clearly define the academic positions of a professor, assistant professor, lecturer, etc. At that time, one chair consisted of only one person but after 1926, one chair had one professor, one assistant professor and two assistants. Through this, the original purpose of strengthening academic work in various fields was achieved. Since then, giant leaps have been made in science and in particular, the increasing importance in research that overlaps other fields has proved that the chair system is not necessarily an effective system. In some cases, it may even become an obstacle to the development of a new academic field. This is especially true when assistants or young researchers mentioned above, are not suited to that

particular kind of research. Some science departments have actually done away with this chair system and turned them into laboratory systems. Since chairs retain their meaning in their particular academic field and there are still advantages when considered from the point of classroom management, they cannot be abolished immediately. However, the chair system must be flexible enough to allow the introduction or development of new academic fields. A more flexible system would be the greater-chair system under which several different chairs with the same academic interest or problems are gathered. There are also demands to alter the one professor-one assistant professor-two assistants ratio depending on the academic field, for the sake of education through the introduction of this greater-chair system. Demands for this type of greater-chair system should be met. There were also proposals to promote one of the two assistants in the current chair to lecturer status while the remaining assistantship is filled by two PDFs, but at the present stage, there are too many opposing this idea. PDF should be separately considered.

4. Budget Increases

National university budgets have been slashed enormously in the past several years. For example, in the past 10 years, the budget for facilities and equipment has been slashed by about 50%. The budget per teaching staff and student has also decreased. Although the science research budget has increased by about 50% and some researchers have taken advantage of this to equip their laboratories, this increase is still insufficient. In other words, the total basic science research budget is still too small when considered on an international level (depicted in References 1 and 2, the budget in 10 Japanese science departments and the budget for science classrooms in the University of Michigan, a typical medium-sized American university. Even the Science Department in the University of Tokyo, with the largest budget, is still small when compared with that at the University of Michigan.). If Japan continues with this trend, basic science research and education would retrograde. As has already been reported, Japan's expenditure for high school education is a mere 0.9% of the national income while in America and advanced European nations, it is 1.5-1.7%. We do understand the difficulties of budgeting but if the basic sciences are to be truly promoted, due investment must be made. This problem is expressed in the answers to an "Improvements in University Education" questionnaire recently conducted by the University Council. Proposals for assigning budgets were also made. American and European students and researchers in Japanese national universities have also expressed concern about the poor research facilities and equipment. Some have even been shocked (Reference 3).

On the other hand, basic research budgets in corporations are significantly higher than national budgets. In fact the investment in basic science research by one major corporation is several times that of the total Ministry of Education's science research budget.

Research is gradually shifting from universities to corporations when considered from the size of investments. But, basic scientific research at universities is not exactly the same as that being done in corporations. Basic scientific research at universities is important for the creation of a more intelligent human culture.

5. Increase in Number of Administrators and Technicians

Staffs at national universities (including teaching staffs) have been greatly reduced in the past few years due to the public official staffs reduction program. The particularly pressing problem in the science departments is the reduction of technician staffs besides the administration staffs (Reference 4). For this reason, production of instruments, their management and operations as well as numerous other technical duties which were supposed to be performed by technicians have now been taken over by the assistants and this in turn results in the assistants having to ignore their own research work. This pressing problem requires urgent measures. American and European universities and research laboratories are well staffed with high quality technicians who enable researchers to concentrate on their work, unlike their Japanese counterparts. American and European researchers in Japan are amazed at the above-mentioned poor facilities but also at the complete lack of technicians and many of them have even warned other foreign young researchers of having to be resigned to dirtying their hands if they want to do research here in Japan.

In order for Japanese universities to continue their activities in frontline research, support staffs like technicians and administrators are essential. Granted that work processes can be simplified and rationalized to cope with the present staff size, but the present staff size is below the minimum. University education and research will reach a crisis if the present situation is maintained. A system whereby technicians with special talents can be employed through mutual consent should be considered. For example, glass molders have become a rare commodity in Japan. These types of talents should be easy to employ.

6. Teaching Staffs Holding Multiple Positions

At present, one teaching staff cannot be attached to several different graduate schools of different majors. However, this should be changed if future koza [chair] are to be effective. In this manner, independent research can be conducted and management will be more easily done. It would be best if teaching staffs versed in not only their majors but also in various other aspects of science can hold different positions.

7. University Museums

The preservation and storage of data and specimens are of the utmost importance in scientific research. As such, there is a strong demand for the establishment of a university museum. Some universities already have their own museums but we propose that all universities should establish their own. This museum will help strengthen

ties between the university and the general public through enlightenment of the public on the results of scientific research funded by national budgets. Besides playing a major role in helping the general public citizens to better understand the important function of national universities, university museums also provide an effective life-time educational location for universities to return to the public what they have gotten out of it. A certain number of staffs will have to be employed for the effective management and running of such a museum. For example, each Korean university must be equipped with both a university library and a museum.

8. Standard Surface Area

An increase in the number of graduate students and foreign students in the science departments of the 10 national universities as well as the expansion of equipment facilities have resulted in an acute space problem. Some faculties have even refused admittance to some foreign students and researchers due to this space problem. According to the results of a survey done by the Federation of Chemical Research Institutes on the surface area occupied by chemical laboratories throughout the world, it was found that the major Japanese universities have only about one-fifth the area commanded by American universities or about one-half that of European universities. We can understand from these figures how small Japanese campuses are. This problem is not only unique to the science department. Take the total surface area taken up by facilities like laboratories in the science departments of the University of Tokyo and Kyoto University (Reference 5a, b) as an example. Reference 5c clearly depicts the situation faced by the chemistry laboratories in the Science Department of Nagoya University. The facilities in most laboratories in the University of Tokyo and Kyoto University take up about 30% of the total surface area available. Some even take up 50% of the area. The remaining available space is entirely too cramped for the teaching staffs and students to coexist without clashing with each other and it would not be an exaggeration if sometimes this will affect research activities. Standard surface area should consider the number of students, foreign students and facilities. However, all Japanese universities have the common problem of not being able to expand their campus land size and as such, future buildings must expand upwards.

9. Active Exchanges Between University Teaching Staffs

It is important for researchers with different backgrounds and majors to interact for the evolution of revolutionary science research ideas. For that reason, exchanges between teaching staffs in universities throughout the nation should be strongly encouraged. To achieve this, for example, researchers not attached to a fixed koza or a guest researchers system should be expanded and a system whereby teaching staffs with tenure should be considered.

10. Improvements in Graduate Schools

Current graduate schools are considered an extension of the undergraduate school without a budgeting section. They are so dependent on the undergraduate program that demands for facilities cannot even be met. This situation has not changed since its introduction in 1946. In recent years, establishment of advanced graduate school facilities were recognized and graduate school budgets were created but, the types of facilities recognized and the budget assigned is still a meager sum. Despite that, the number of graduate school students has steadily climbed at least in the science departments in the 10 national universities. In some universities (for example, the University of Tokyo), the number of science graduate students has overtaken that in the undergraduate program (Reference 6). The role of research conducted by science graduates is increasing in importance. All these conditions are not conducive to the promotion and development of science education and research and as such, they must be improved at the fastest possible speed. Several universities have already started considering these improvements and concrete proposals have already been made (References 8 and 9). Although improvements in the graduate school program differ in each university, the science departments in the 10 national universities should strongly stress the importance of the graduate school program. This was already reported in papers submitted by the Graduate School Sub-Committee under the University Council and we would like to take this opportunity to emphasize this point again.

Conclusion

The ideals of Japanese science education and research were explained. The major problems and concrete countermeasures were given in the form of a summary of the opinions and proposals by the deans of science departments in 10 universities. Some of the proposals were made by the universities, teaching staffs and students, the main parts represent demands on the related governmental organizations. Most of the demands were already well understood by the related bodies but we take this

opportunity to express them again. We did this because we believe that this is the one and only way to clearly depict the miserable condition of Japanese science education and research when even the comparatively better-off 10 national universities are nothing when held to international standards. We are strongly convinced that Japan should completely alter all its university standards and conditions before Japan can attain world level science education and research, maintain it and through that contribute to progress in the basic sciences for mankind. We also fervently hope that the demands and wishes proposed here will be realized.

References

1. Annual budgets for science departments in 10 universities.
2. Annual budget for science laboratories at the University of Michigan.
3. Comments by an expatriate scientist on research laboratories in Japanese national universities and corporations (1 copy).
4. Personnel transfers of administrators and technicians within the 10 national universities.
5. Surface area and percentage of space occupation by equipment in science departments of Tokyo University and Kyoto University (a, b). Current problems faced by chemistry laboratories in the science department of Nagoya University (c).
6. Number of students and research students in science departments and science graduate schools in 10 national universities.
7. Total number of doctorate awards conferred in 10 national universities.
8. Tokyo University, Graduate School Improvement Concept (Science Graduate School Concept)—attached.
9. Hokkaido University, Graduate School Improvement Concept (Science Graduate School Concept)—attached.

Reference 1 (Unit: per thousand yen)

	Fiscal year 1990					Fiscal year 1991				
	School fees	Science research fees	Management budget	Research budget	Total	School fees	Science research fees	Management budget	Research budget	Total
Hokkaido University	594,501	332,975	78,380	15,777	1,021,633	600,159	292,573	107,022	16,912	1,016,666
Tohoku University	642,679	722,900	126,744	41,756	1,534,079	656,164	585,068	111,270	36,716	1,389,218
Tsukuba University	371,477	315,200	65,818		752,495	406,402	393,100	72,011		871,513
Tokyo Institute of Technology	303,096*	326,262	131,757	7,325	768,440	257,334*	228,000	73,379	20,104	578,817
University of Tokyo	840,488	1,248,874	223,792	50,384	2,363,538	852,565	1,529,208	343,324	76,973	2,802,070
Nagoya University	561,089	693,350	35,525	47,362	1,337,326	559,149	629,330	86,042	45,161	1,319,682
Kyoto University	698,669	767,937	66,845	35,406	1,568,857	709,021	893,200	66,512	29,259	1,697,992
Osaka University	660,737	365,180	97,336	20,514	1,143,767	658,610	325,300	80,623	19,820	1,084,353
Nagoya University	443,777	131,760	18,450	6,593	600,580	456,871	188,980	42,414	9,353	697,618
Kyushu University	402,413	302,620	64,411	5,448	774,892	405,646	257,000	86,842	6,658	756,146
University of Michigan										2,956,281 ⁺

+: fiscal year 1989 (details attached)

*: excluding electrical and water expenses

Reference 2. Annual Budget for Science Laboratories at the University of Michigan (excluding personnel expenses)
(July 1988-June 1989)

Mathematics	\$ 399,760.20	¥ 51,968,826
Physics	3,592,183.42	466,983,845
Information Science	5,911,913.87	768,548,803
Astronomy	307,248.75	39,942,338
Earth Physics	4,726,369.51	614,428,036
Chemistry	2,906,317.10	377,821,223
Biochemistry	1,477,205.92	192,036,770
Biology	1,229,481.14	159,832,548
Anthropology	178,424.72	23,195,214
Geology	1,834,509.58	238,486,245
Biological Gardens	177,210.02	23,037,303
Total	22,740,624.23	2,956,281,150

Exchange rates \$1.00 = ¥ 130.00

Reference 4. Personnel Transfers of Administrators and Technicians (personnel reduction condition)

	1981		1986		1990		1990 as a percentage of 1981	
	Administrators	Technicians	Administrators	Technicians	Administrators	Technicians	Administrators	Technicians
Hokkaido University	81	44	75	38	71	31	87.7	70.5
Tohoku University	82	82	81	72	75	64	91.5	78.1
Tsukuba University	19	49	19	46	18	39	94.7	79.6
Tokyo Institute of Technology	37	24	33	22	33	15	89.2	62.5
Tokyo University	97	94	98	83	100	75	103.1	79.8
Nagoya University	80	48	70	42	68	42	85.0	87.5
Kyoto University	92	73	76	75	76	58	82.6	79.5
Osaka University	62	27	54	26	50	23	80.7	85.2
Hiroshima University	60	22	52	20	50	16	83.3	72.7
Kyushu University	90	30	80	28	73	26	81.1	86.7

Reference 5a. Crowding Survey on Space Occupied by Equipment in Tokyo University

	Number of residents (persons)	Room area (m ²)	Area occupied by equipment (m ²)	Space occupation ratio (%)
Mathematics	43	2,523	671.27	26.61
Information Science	73	1,778	525.23	29.54
Physics	289	6,779	2,538.42	37.45
Astronomy	85	1,103	463.01	41.98
Earth Physics	65	1,677	516.35	30.79
Chemistry	171	5,696	2,070.74	36.35
Biochemistry	81	2,380	878.64	36.92
Zoology	77	1,647	595.12	36.13
Botany	74	1,995	772.07	38.70
Anthropology	24	722	260.16	36.03
Geology	34	1,828	603.23	33.00
Mining Engineering	27	966	266.44	27.58
Geography	37	749	283.38	37.83

Reference 5b. Kyoto University

	Number of residents* (persons)	Room area (m ²)	Area occupied by equipment (m ²)	Space occupation ratio (%)
Mathematics	220	876	416	47.5
Physics	344	2,613	1,448	55.4
Space Physics	50	915	435	47.5
Earth Physics	101	567	269	47.5
Chemistry	253	2,547	1,019	40.0
Zoology	74	900	352	39.1
Botany	63	347	165	47.5
Geology/Mining Engineering	83	1,030	376	36.5
Biophysics	137	1,174	485	41.3

*Includes students

Reference 6. Number of Students

	Undergrads	Masters	Doctors	Research
Hokkaido University	635	271	155	35
Tohoku University	660	337	216	43
Tsukuba University	1,337	541	286	34
Tokyo Institute of Technology	771	283	93	49
Tokyo University	659	593	579	68
Nagoya University	589	216	164	50
Kyoto University	744	373	369	113
Osaka University	478	262	182	15
Hiroshima University	594	182	82	34
Kyushu University	591	232	98	31

Reference 7. Number of Doctorates Conferred

	Fiscal year 1989		Fiscal year 1990	
	Kateihakasei Resident degree	Ronbunhakasei Non- resident degree	Kateihakasei Resident degree	Ronbunhakasei Non- resident degree
Hokkaido University	29	29	31	16
Tohoku University	44	26	46	18
Tsukuba University	27	26	8	6
Tokyo Institute of Technology	28	11	14	10
Tokyo University	135	50	125	43
Nagoya University	30	17	29	28
Kyoto University	77	40	54	32
Osaka University	34	15	34	8
Hiroshima University	15	26	13	16
Kyushu University	23	17	16	13

Summary of the First Symposium on Intelligent Materials

91FE0769A Tokyo PROMETHEUS in Japanese
May-June 91 pp 54-55

[Article by Shoki Watanabe, Science and Technology
Agency]

[Text] The First Symposium on Intelligent Materials was held at the conference hall of the National Mutual Insurance Federation of Agricultural Cooperatives (Chiyoda-ku, Tokyo) on 22 March 1991. The conference was organized jointly by the Association of Unexplored Science and Technology and the Intelligent Materials

Forum and was supported by the Science and Technology Agency. Contrary to organizers' concerns, over 200 participants filled the conference hall, a great success for the first symposium on materials based on a new concept—intelligent materials. This popularity indicates widespread public recognition of "intelligent materials," which perform three separate functions: sensing, information processing and activating and reacting intelligently to changes in the external environment.

Twenty-one research papers were presented at the symposium and active question and answer sessions took place. Of the papers reported, two were on metals, two on ceramics, two on micro-machining and the remainder on polymers and biological materials. As can be seen from these numbers, polymers and biological materials seem to present the best possibility of performing intelligent functions at present. Polymers and biological materials are probably more likely to succeed because they are "soft and flexible" and thus easily perform the aforementioned functions, while metals and ceramics are too "stiff" for such purposes. For the same reason, many presentations on polymers and biological materials were videos—easy and fun to watch—as in the saying: Seeing is believing.

We summarize the presentations in each area below.

Metals

(1) A conceptual application of fractals was proposed to develop intelligent materials. For instance, variations in the upper critical magnetic field generated by fractal structures in superconductors and normal conductors were presented.

(2) For self-diagnosis of internal degradation and micro-cracks on surfaces of structural materials, a method to detect strain in an aluminum-plate specimen using the piezoelectricity of polyvinylidene fluoride (PVdF) was introduced. In this research, PVdF was either vaporized on the specimen surface or a film of PVdF was coated onto the specimen. The specimen itself does not detect degradation or cracks.

Micro-machining

(1) A miniature intelligent system was fabricated using semiconductor processing techniques by integrating sensors, logic circuits, and many two-dimensionally arranged actuators whose size is of the order of microns. Ciliary motion was demonstrated using cantilevered actuators made of polyimide films.

(2) A proposal was presented to create intelligent materials from an artificial surface using a scanning tunnel microscope as an atomic manipulator to process the surface.

Ceramics

(1) A gas sensor using a zinc oxide ceramic, and a selective gas sensor using the heterogeneous contact between zinc oxide and copper oxide, were presented.

(2) The development of intelligent functions by controlling the grain boundaries of semiconductor ceramics was explained in terms of perovskite semiconductors.

Polymer and Biological Materials

(1) A reaction caused by light emitted by a metallic complex of halogen ions arranged in a straight chain was reported. This study concerns nonlinear optical properties (generation of the second harmonic) of a Langmuir-Blodgett (LB) film containing rare-earth ions.

(2) Three studies on polymer gel actuators were reported. Typical examples are shown in Figures 1 and 2. Figure 1 illustrates the motion of a PAMPS (polyacrylamide-methylpropane-sulfonic acid) gel in a micelle solution, when one end of the gel is attached to the cover and a direct current is passed through the solution. The gel bends toward the positive pole, bending in the opposite direction when the electric current is reversed. Figure 2 illustrates the inchworm-like motion of the same kind of gel, when the gel is hung from a saw-toothed support and subjected to a vertical electric field. A video of the actual motion was shown. The third paper described the motion of a gel by thermal contraction. Future applications for artificial muscles are being considered.

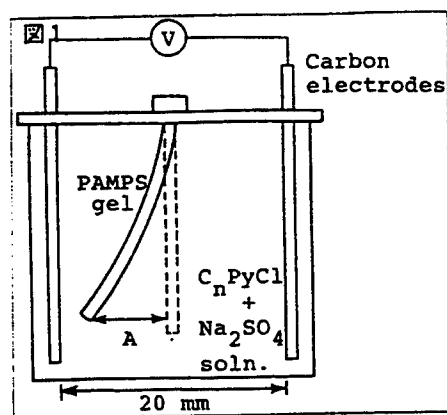

Figure 1.

(3) The largest number of papers was devoted to automated drug delivery systems. As is shown in Figure 3, a polymer capsule is filled with a drug, and the capsule expands when the temperature rises and contracts when the temperature falls, thus administering the drug directly to an infected area in the body instead of orally taken the drug. Using a similar technique, a capsule with an artificial pancreas function was reported. The capsule releases insulin after diagnosing the glucose level in blood.

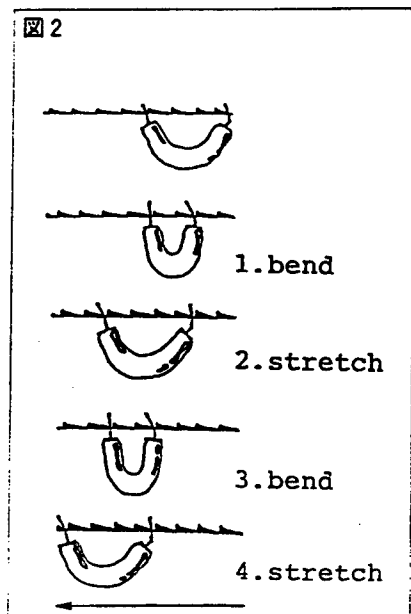

Figure 2.

(4) Three studies on biological materials were reported—on a photosensitive microbe, a cellular information system using proteins, and the behavior of microtubules in a cell.

Comments during Panel Discussions

At the end of the lectures, there was a panel discussion. Regarding electronics, Aoyagi (Institute of Physical and Chemical Research) speculated that “electronics will develop further if one can make the material itself intelligent. In such a case, the material will become intrinsically monolithic.” Regarding metals, Niino (National Research Institute for Metals) asked: “Intelligent structural materials should have self-diagnosis and self-repair functions, but at the moment the focus is on mass production. Isn't it also important to develop powder materials with intelligent functions?” Regarding polymers, Miyata (Tokyo University of Agriculture and Technology) proposed to “invent materials that generate a potential minimum, depending on external conditions, by varying the main and side chains.” Regarding biological materials, Aizawa (Tokyo Institute of Technology) claimed that “It is necessary to classify and study HOW data are transmitted, since elementary functions, even when they appear at the level of individual molecules in a protein, are likely to be intelligent.” Regarding medical applications of biological materials, Okano (Tokyo Women's Medical College) commented: “Intelligent materials will open a new academic discipline. Existing disciplines probably cannot handle intelligent materials because of the concept of data. The new discipline must be able to handle nonequilibrium and dynamic conditions. We should consider how to challenge this new field at the edge of academia.”

図3 高温放出低温停止型薬物担体へのアプローチ

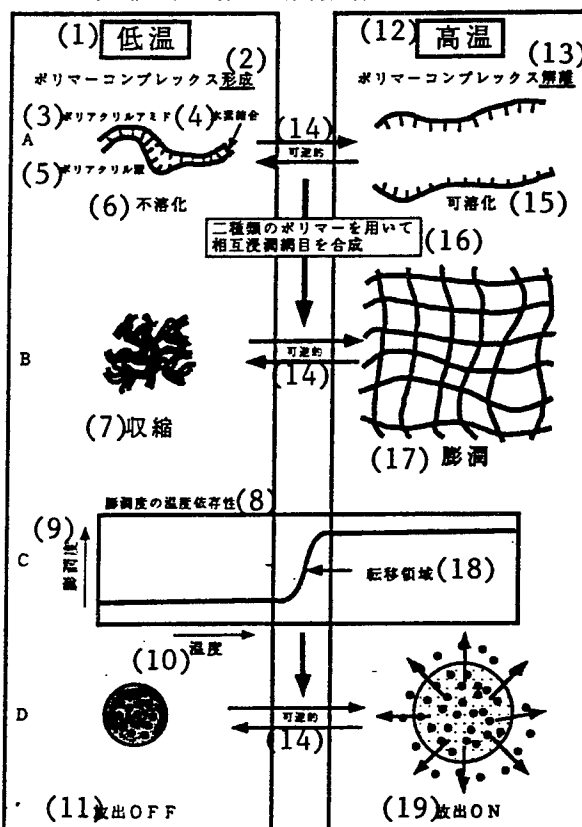

Figure 3. A drug carrier that releases the drug at high temperatures and stops at low temperatures.

Key:—1. Low temperature—2. Forms polymer complex—3. Polyacrylamide—4. Hydrogen bonding—5. Polyacrylic acid—6. Becomes insoluble—7. Contraction—8. Dependence of the degree of swelling on temperature—9. Degree of swelling—10. Temperature - 11. Release off—12. High temperature—13. Polymer complex dissociates—14. Reversible—15. Becomes soluble—16. Synthesizes a mutually wetting net using two types of polymers—17. Swelling—18. Transition region—19. Release on

Summary of the 12th Functionally Gradient Materials Forum Workshop

91FE0769B Tokyo PROMETHEUS in Japanese
May-June 91 pp 60-61

[Text]

Introduction (by Junichi TERAOKI of Daikin Industries)

On 19 March 1991, the Twelfth Workshop of the Functionally Gradient Materials [FGM] Forum was held at the MEC [Mechanical Engineering Center] Laboratory of Daikin Industries in Tsukuba science town. The

speakers at this workshop were participants of the "basic technology study to develop FGMs to reduce thermal stress" as well as researchers working in fields related to FGMs. The workshop was held so that members of the FGM Forum (an affiliate of the Association of Unexplored Science and Technology) could listen to—and discuss—research results not only on heat-resistant materials but also on a wide range of fields, such as biology and optics. The workshop has been held three or four times a year since 1988: this one was the twelfth. This was the first workshop of the Forum held in the Tsukuba area. About 60 participants from many firms and research laboratories attended the workshop, for the participants were also scheduled to visit the Tsukuba Space Center (National Space Development Agency [NASDA]), Mechanical Engineering Laboratory, and the National Laboratory for High-Energy Physics on 20 March.

Three lectures on FGMs were presented at the workshop and are listed below.

I. Current Status and Future Tasks of the Heat-Resistant Structural and Material Studies for HOPE (by Masataka YAMAMOTO, NASDA)

HOPE is a rocket-launched, winged, reusable spacecraft that will be installed on the top stage of the H-II rocket and launched. HOPE resembles a small space shuttle, and will be used to transport materials to, and retrieve experimental results from, a space station. The initial basic design is being carried out by NASDA with the goal of launching an experimental craft within this century. At present, a plan to upgrade HOPE's fuselage size from 10 tons to 20 tons is under discussion. The outside shell

of the main fuselage structure must be covered by thermal protectors. The inside of the shell must also be lined with thermal insulation to protect the instruments inside, for the leading edges of the fuselage will reach a maximum temperature of 1,700°C and a minimum of 300°C due to atmospheric heating during reentry into the atmosphere. The leading candidates for the heat-resistant materials are C/Pi for relatively cool areas and C/C composites for hot areas.

In addition, results of characteristic vibration analyses and flutter analyses were presented. The necessity to re-examine rigidity requirements in the future was pointed out because in the current design, HOPE's weight is expected to substantially exceed that in the original plan.

II. Functional Coating by Laser-Plasma Hybrid Fluid Injection (by Nobuya SASAKI of the Mechanical Engineering Laboratory)

This lecture concerned functional coating to prevent rapid oxidation of the C/C material used in hot areas, related to the C/C composites mentioned earlier. The basic idea of functional coating is to apply multiple coatings, with each layer having a separate function to make the C/C material super-resistant to diverse environments—such as erosive or corrosive environments—in addition to being heat resistant as in gas turbines. Such a coating technique can be considered functionally gradient coating. This particular application consisted of five layers, as shown in Table 1. Laser-plasma hybrid liquid injection was used to apply coatings to improve the bonding between the coated layers and the base material, and to remove pores.

Table 1. Environment-resistant, composite, multilayer coated films.

Coated layer	Purpose of coating	Material
First coating	Coating to improve the bonding with C/C material	W, Mo, WC
Second coating	Oxidation-resistant, self-sacrificing coating	MoSi2
Third coating	Oxidation-resistant, oxygen barrier coating	Pt, Ir
Fourth coating	Heat-resistant coating	PSZ
Fifth coating	Erosion and corrosion resistant coating	ThO, PSZ

III. Artificial Bones and Joints with Gradient Functions at the Contact Surfaces between Bones and Biomaterials (by Keisei ONISHI, National Osaka South Hospital)

To bond artificial joints to bones, one can (1) directly bond artificial joints and bones; (2) mechanically join them by screws; or (3) fill the space between a bone and a joint with a bone cement. Recently, a bonding method has been developed utilizing the fact that bone tissue grows on artificial joints that have porous, metallic surfaces. The subject of this lecture, which included some clinical applications, concerned coating hydroxyapatite (HAp) on an artificial joint to bond the joint to a

bone through physical chemistry and increase the bonding strength. The lecture also discussed a method to make only the contact surfaces a bioactive bone cement by introducing one or two layers of HAp granules between a bone and a bone cement to remove difficulties that arise at the contact surfaces between a bone and conventional bone cements. Either method has the advantage that bonding strength does not deteriorate even after an extended time period when compared to existing methods. This application seems to have succeeded in developing a clever usage of an FGM, whose strength at boundaries does not deteriorate.

Komatsu Chairman on Company's European Strategy

91MI0469X *Duesseldorf HANDELSBLATT in German*
19 Aug 91 p 11

[Article by Andreas Gandow: "An Insider in the European Market"]

[Text] Japan's leading manufacturer of construction machinery, Komatsu Ltd of Tokyo, is presently increasing its involvement in the new fields of semiconductor and robot technology and in industrial engineering in order to develop into a "total engineering" company. According to a HANDELSBLATT interview with Komatsu President Tetsuya Katada, the company's plans for the EC, following its takeover of Hanomag AG, are to enter into cooperation with European manufacturers, to push hard to extend involvement in large-scale presses for the automobile industry, and to create in a short period of time a base for electronic components.

During fiscal year 1990-91 (ending 31 March 91) the company was able to consolidate its increase in revenues, which rose by 11.5% to ¥988.9 billion, or almost 12 billion German marks [DM], domestic sales rose by 12.8% to ¥688 billion, while overseas sales rose by 8.5% to ¥300.9 billion. Of these totals, ¥660.5 billion (+9.4%) or 67% were accounted for by the construction machinery sector; ¥86.7 billion (+30.4%) or 9% by industrial machinery (presses and robots); and ¥241.8 billion (+12%) or 24%, by the company's other new business activities including silicon wafers, plastics, pre-fabricated components and software development. Profits rose over the same period by 14.6% to ¥31.3 billion (around DM375 million).

For the current 1991-92 fiscal year, the company expects an 8% increase in revenues to ¥1,030 trillion to yield corresponding post-tax profits of ¥33.5 billion. Katada's projections for the present fiscal year for both the domestic and overseas market take into account an anticipated worsening of the economic situation in the U.S., large parts of Europe and southeast Asia, shortages of overseas currency in the former eastern bloc, and the debt crisis facing developing countries, together with stagnating revenues in the construction machinery sector.

The impulse for the increase in revenues is expected to be provided by a further above-average expansion of the company's other business activities, which in the medium term will account for half the total revenues. Those sectors whose overseas revenues remain at less than 10% of the total, are to increase substantially their sales in the European market, Katada reports.

The company's European involvement, which expanded substantially during fiscal year 1990-91 by 25% to ¥100 billion (some DM1.2 billion) and is controlled by Komatsu Europe International SA set up at the end of 1989, falls into four production areas:

Komatsu UK Ltd: an excavator factory operating in Great Britain since 1985, with production of 1,800 units per year. A European production share of "over 70%" by value has already been achieved. Katada reports that the present target, in accordance with undertakings given to the British government, is a level of 80%. Following the takeover of Hanomag, however, the planned annual production of 1,200 wheel loaders has been abandoned.

In Italy, Komatsu has been cooperating with the construction machinery manufacturer FAI Spa since July 1988. In mid-1989, the company contracted to produce mini-excavators of Japanese manufacture for the European market, and Katada now reports a limited capital participation in FAI, to support cooperation in business activities; discussion on this matter with the Italian partner are still proceeding.

The production base in Germany is Hanomag AG of Hanover, taken over on a majority shareholding basis (presently involving 64% of capital) in 1989; investment in modernization in the fields of production technology and data processing presently totals around DM50 million since, according to Katada, no new investment whatever had been undertaken during the five years before the takeover. He is now confident, however, of profits being achieved by Hanomag AG in the coming fiscal year. Katada says that, "We were convinced from the start that with suitable restructuring and with this investment program we could make Hanomag AG successful again. An additional aim, however, was to become insiders in the European market by means of this takeover. It would have been possible for us to proceed alone, but this is the better way for Japanese companies."

In Norway, Komatsu has founded a joint venture with the state company Olivin AS for the production of trucks with articulated bogies. The Japanese company will hold a third of the capital of the joint venture, Moxy Truck AS, which will build the special truck with Komatsu's know-how and be responsible for worldwide distribution of the vehicles. The Norwegian company Brown Engineering has hitherto been the supplier for vehicles of this type.

Expansion of R&D Capacity To Include Germany

Future priorities, according to Katada, include the appointment of Europeans to management positions, the expansion of development capacity in Great Britain and Germany, the development of a European research center, the development of further collaborative ventures with European construction machinery manufacturers, and expansion in the other new sectors in which the company is active.

In his discussions with the European association for the sector, CECE (Committee for European Construction Equipment), says Katada, there was a general consensus that market development had been marked by stagnation in demand and overcapacity; therefore, all manufacturers were now engaged in "under the table" negotiations on cooperation opportunities.

Therefore, Komatsu does not see discussion centering on the creation of further capacity in the construction machinery sector, but rather on agreements on cooperation which would be beneficial to both sides. The European side includes numerous medium-sized manufacturers with a broad product range, Katada emphasizes, for whom such collaboration could make good business sense; Komatsu is even prepared to postpone its own European development project for a wheel loader.

The massive participation by Korean construction machinery manufactureres at the last trade fair in Paris surprised even Katada, he admits. The three leading Korean manufacturers obviously have a strategy of making a significant impact on the European excavator market which could conceivably give cause for alarm among some European manufacturers.

This does not however, constitute a threat to his own company, as the experience of southeast Asian markets has already shown: Katada bases this belief both on the technical standard of the Korean exhibits, and also on the unfavorable pricing arising from lower production volumes.

As far as future involvement in the construction machinery market in central and eastern Europe is concerned, Katada stresses that even before the political upheavals there had already been contacts between the U.S. joint venture, Komatsu Dresser Co., and Hanomag AG with suppliers in Poland and Czechoslovakia. Visits to these companies, which were subsidiaries of tank factories, had revealed a "surprisingly modern standard of production technology."

It is now questionable whether these subsidiaries can remain competitive on cost; Komatsu, Katada states, has made "various investigations" with a view to involvement in this region. Developments in the respective markets are being closely monitored, but he does not expect any decision in the near future. Furthermore, the takeover of Hanomag AG in central Europe is proving to be very positive, as it could lead to the opening-up of markets in central and eastern Europe.

In addition to these activities in the construction machinery sector,, Katada also reports a strengthening of

sales of machines and systems for sheet metal working and for the plastics industry, together with an expansion of business in large-scale presses for the automobile industry, one of the company's traditional products supplied to all Japanese manufacturers as well as to three U.S. automobile manufacturers. For the first time, contracts have been concluded with Fiat, from whom orders are now awaited. Komatsu will also supply the European production centers of Nissan and Toyota with presses.

Wafer Production Imminent in Europe

The third area mentioned by Katada in which there will be future involvement in Europe is that of wafer production for the manufacture of memory chips, for which the group's Komatsu Electronic Metals Company is responsible. The company occupies a very strong competitive position internationally in silicon wafer production and, following the expansion of production by Japanese chip manufacturers in Europe, it will set up its own production base in this region, which for long has not been adequately supplied on grounds of capacity: "before 1995," reports Katada.

Having achieved revenues of over ¥1 trillion in the current fiscal year, the medium-term aim of the entire company's strategy is to achieve revenues of ¥1.5 trillion by the mid-1990's, states Katada. This cannot however, be achieved with construction machinery as at present; the future priority is to integrate the present individual industrial manchiney and robot construction units into systems and to market them together with software and engineering services. The second significant sector "in which we are all concentrating our forces, as it will develop into an important market," is the development of robots of all kinds for structural engineering, such as the installation of heavy wall panels and painting. Not only does the acute labor shortage give grounds to expect strong demand from traditional customers in the construction industry; but the company already possesses substantial expertise in this area, according to Katada. Revenues in the entire robotic sector are therefore expected to rise from ¥5.5 billion (some DM65 million, of which some DM12 million are accounted for by robots in the construction industry) to ¥10 billion in the present year and ¥25 billion by 1995.

Development Trends in Functionally Gradient Metals

916C3802A Tokyo SPECIAL LECTURE SERIES:
OUTLOOK FOR JAPANESE TECHNOLOGY IN THE
21ST CENTURY in Japanese Nov 90 pp 7-14

[Article by Kenji Wakashima, Tokyo Industrial University's Precise Engineering Research Institute; Tohru Hirano, Daikin Industries's CAE Center; and Masayuki Niino, Aviation Space Technology Research Institute, Tsunoda Branch Office: "Focused on the Material Design"]

[Text]

1. Introduction

Modern, leading edge technologies, which focus on material, as well as optoelectronic, information systems, biotechnology, and life science, are the building blocks that support the future industries of Japan. Moreover, the Japanese Government recently advocated the establishment of a technological state. In fact, these technologies, however, have become controversial because some areas of the world accuse Japan of piggybacking on technologies developed by the other countries to emerge as an economic superpower, enjoying marked economic progress from the fruit of the leading edge technologies developed by the other advanced countries. Because of these international frictions, every competing country knows it must concentrate on basic technological research and studies directed at the development of 21st century revolutionary technologies. Our government has promoted various measures reflecting this effort for the past decade.

The "Creative Science Technology Promotion Project," which began in 1983 under the auspices of the Agency of Scientific Technology, and the "Next Generation Industry Substructure Technological Research and Development System," which was promoted by the Agency of Industrial Science and Technology of the Ministry of International Trade and Industry, show these Japanese Government efforts in the former projects, micro fine particles, special structural materials (noncrystallization compounds and interlaminar compounds), fine polymers, and perfect crystals are used in the study of material science. In the latter case, we are now researching the effects produced by fine ceramics, high-performance crystal control alloys (single-crystal ultra-heat-resistant alloys, fine particle ultra-plastic alloys, and particle-dispersion resin-forcing alloys), composite materials (resin and ceramic groups of reinforcing materials), high-crystalline polymers, conductivity materials, and highly efficient polymer-release film. The basic research on these new materials is being facilitated by cooperation between industry, the administration, and the academic world in the last five to six years, thus triggering an explosion of new materials.

In this article, the authors will discuss "research on the basic technology for the development of functionally

gradient materials for thermal stress relaxation" (hereafter called the "FGM Project"), which is a joint research project promoted by industry, government, and academia based on the five-year plan started in 1987 when this project received "scientific technology promotion funds from the administration" through the Agency of Science and Technology. First, the authors will define "functionally gradient materials (FGM)" and briefly outline the research system for this project. Then, we will focus on how we have designed our material and comment on our definition of thermal stress analysis, which is the main topic of this project, and how we design thermal stress relaxation of FGM using thermal stress analysis by giving simple and concrete examples where possible.

2. What Is a Functionally Gradient Material (FGM)?

"FGM" is a technical term recently coined to contrast these materials with the conventional materials produced uniformly on a macro scale.¹ As clearly indicated in the schematic view in Figure 1, FGM is "a composite material" comprising a combination of entirely different materials (mainly ceramics and metals). FGM is considered a "conjugated group material." However, a marked feature of these materials is a continuous transition on a macro scale unlike conventional composite materials or conjugated materials. This clearly indicates that FGM is extremely different from "those materials" defined in the standard way. Rather, it is a group or "structure" produced by a combination of dissimilar raw materials. Therefore, FGM is not a modification of existing material or conventional concepts of it, but a completely new material. The intended function of the new materials can be achieved by controlling the transition of the materials on a macro basis. Therefore, the end use must be determined before resolving deciding how to grade the quality. More specifically, to create the FGM, "the material" assumes the most importance.

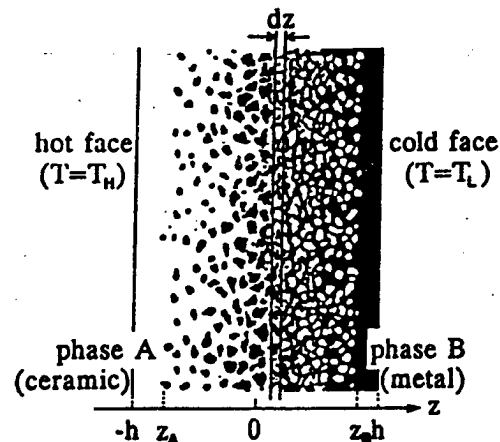

Figure 1. Schematic View of Functionally Gradient Material

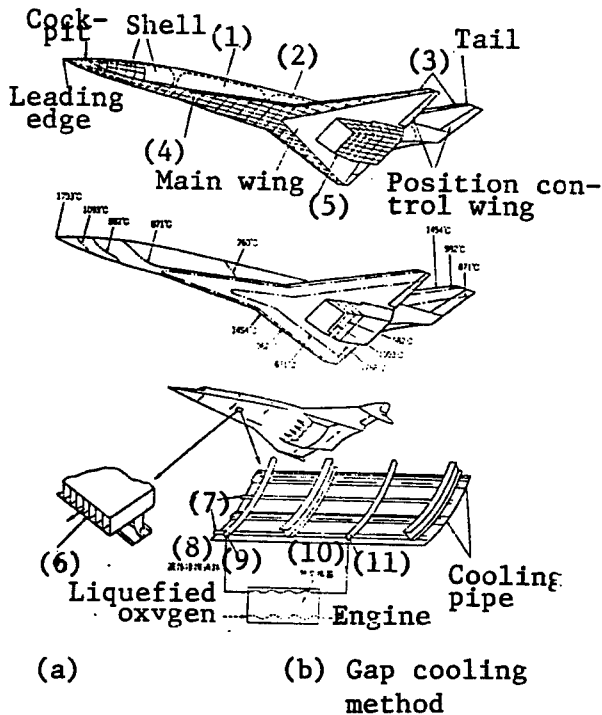

Figure 2. Space Plane and Its Thermal Insulation Structural Material (conceptional view)

Key:—1. Passenger chamber and cargo chamber—2. Liquefied oxygen vessel—3. wing front—4. Underside heat resistance shield—5. Air suction mixing port unit—6. Heat exchanger and thermal insulation material—7. Reinforcing material—8. Liquid cooling passage—9. Supply port—10. Heat exchanger—11. Return port—a. [Illegible]

3. FGM Project

The FGM Project has been engaged in basic research to develop heat resistant structural materials, specifically the ceramics-metal group FGM. More specifically, as

illustrated in Figure 2, our project is in the early stage of applying FGM to active-cooling heat-protection materials exposed to harsh aerodynamic heating, such as the development of a nose or leading edge for an ultra supersonic flying object (space airplane). For FGM structural materials that are sheet-shaped or granular at

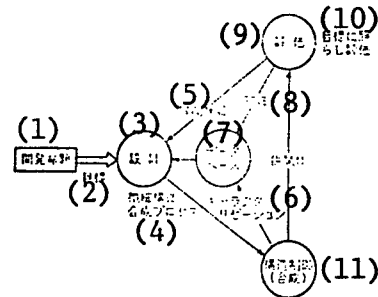

Figure 3. Research Promotion System for FGM Project

Key:—1. Development organization—2. Target—3. Design—4. Microstructure synthetic process—5. Performance guarantee—6. Characterization—7. Data base—8. Properties—9. Evaluation—10. Evaluate in reference to the target—11. Structural control (synthesis)—12. Test material

a thickness ranging from 1 to 10 mm, we have set our target values, specifying the maximum surface temperature on the ceramic side as 2,000 K and the maximum head within the material as 1,000 K.

As illustrated in Figure 3, the research system that supports this project has three sections: material design, structural control, and characteristic evaluation. These sections are the core of our project system and maintain organic cooperation. Table 1 summarizes the themes for each section and the organizations in charge. In the first phase (1987 to 1989), basic research was emphasized to produce FGM, but, in the second phase (1990 to 1991), the project team is expected to broaden its technological development from basic research to application.

Table 1. Research on Basic Technology for the Development of Functionally Gradient Materials for Thermal Relaxation (Based on Science and Technology Promotion Control Fund)

Phase 1 (1987 to 1989)	Phase 2 (1990 to 1991)
1. Research on Material Design Technology for Functionally Gradient Materials	
1) Physical property data estimation technology for functionally gradient materials (Tokyo Industrial University, Precision Engineering Research Institute) 2) Functionally gradient material theoretical model and thermal stress analytical method (National Aerospace Laboratory, Science and Technology Agency) 3) Computer-aided material design support system (Daikin Industry)	1) Elasticity analytical data estimation method based on microstructure model (Tokyo Industrial University, Precision Engineering Research Institute) 2) Measurement method for thermal physical property values and data analysis (Shizuoka University, Engineering Faculty) 3) Measurement method for high-temperature strength and data analysis (Mechanical Engineering Laboratory, Agency of Industrial Science and Technology, Ministry of International Trade and Industry) 4) Gradient structure thermal stress analytical model and data analysis method (1) Analysis based on two-dimensional structural laminated board (National Aerospace Laboratory, Science and Technology Agency) (2) Analysis based on three-dimensional structural infinite element model (Power Reactor and Nuclear Fuel Development Corporation) 5) Optimum design system (Daikin Industry) 6) Actual environmental structure design technology (Nissan Motor) 7) Investigation research into design boundary condition (Future Science and Technology Institute, Ltd.) 8) Data base and knowledge base building up (National Aerospace Laboratory, Science and Technology Agency)
2. Research on Structural Control Technology for Functionally Gradient Materials	
1) Structural control technology based on physical and chemical deposition process (1) Physical vapor deposition composition gradient precision control technology process (National Research for Metals, Science and Technology Agency) (2) Chemical vapor deposition process (Tohoku University, Metallic Material Technology Research Institute) (3) Physical and chemical vapor fusion process (Sumitomo Electric Industries) 2) Structural control technology based on particle process (1) Particle injection process (Tohoku University, Engineering Faculty) (2) Thin film lamination process (NKK) 3) Structural control technology based on flame spray process (1) Dissimilar particle independent flame spraying process (National Research for Metals, Science and Technology Agency) (2) Dissimilar particle simultaneous flame spraying process (Nippon Steel) 4) Self-heating generation reactive process-based structural control technology (1) Reaction control technology (Osaka University Industrial Science and Technology Research Institute) (2) (Wide area control technology (MITI, Agency of Industrial Science and Technology, Tohoku Industrial Laboratory)	1) Structural control technology based on physical and chemical deposition process (1) Physical vapor deposition composition gradient precision control technology (Tohoku University, Metallic Material Laboratory) (2) Sophisticated configuration functionally gradient material manufacturing technology based on physical vapor deposition and fusion process (Sumitomo Electric Industry) 2) Vapor phase penetration process-based three-dimensional tilting technology (Nippon Oil) 3) Particle injection process-based three-dimensional tilting technology (1) Net shape control in sophisticatedly-shaped functionally gradient materials (Tohoku University, Engineering Faculty) (2) Particle injection process-based sophisticatedly-shaped functionally gradient material manufacturing technology (IHI) 4) Lamination process process-based structural control technology (NKK) 5) Flame spraying process-based structural control technology (1) Flame spray process-based more compact functionally gradient material (National Research for Metals, Science and Technology Agency) (2) Flame spray process-based sophisticatedly-shaped functionally gradient material manufacturing technology (Nippon Steel) 6) Self-heat generation process-based structural control technology (1) Temperature distribution control in self-heat generation reactive process (Osaka University, Industrial Science Laboratory) (2) Improvement in oxidation-proof performance (MITI, Agency of Industrial Science and Technology, Tohoku Industrial Laboratory) (3) Self-heat generation reactive process-based sophisticatedly-shaped functionally gradient material manufacturing technology (Kawasaki Heavy Industries)

Table 1. Research on Basic Technology for the Development of Functionally Gradient Materials for Thermal Relaxation (Based on Science and Technology Promotion Control Fund) (Continued)

Phase 1 (1987 to 1989)	Phase 2 (1990 to 1991)
3. Research on Property Evaluation Technology of Functionally Gradient Materials	
1) Quantitative evaluation technology for local thermal stress 2) Thermal insulation performance evaluation technology (National Aerospace Laboratory, Science and Technology Agency) 3) Thermal and mechanical characteristic overall evaluation technology (1) Thermal fatigue properties (Mitsubishi Heavy Industries) (2) Thermal impact properties (Tohoku University, Engineering Faculty) (3) Mechanical properties (MITI, Mechanical Engineering Laboratory, Agency of Industrial Science and Technology)	1) Ecology/corrosion characteristic evaluation technology (Tohoku University, Engineering Faculty) 2) Thermal stability evaluation technology for functionally gradient materials (National Research for Metals, Science and Technology Agency) 3) Quantitative nondestruction inspection technology (1) Evaluation technology for fine area functionally gradient materials (Tohoku University, Engineering Faculty) (2) Deterioration and damage evaluation technology (Ship Research Institute, Ministry of Transportation) (3) Nondestruction inspection technology for large functionally gradient materials (Hitachi Construction Machinery) 4) Thermal fatigue evaluation technology in the field of temperature drop (1) Thermal fatigue and damage mechanism of functionally gradient materials (Mitsubishi Heavy Industries) (2) Structural soundness evaluation for functionally gradient materials (National Aerospace Laboratory, Science and Technology Agency) 5) Property evaluation technology based on large thermal impact test (Japan Atomic Energy Institute) 6) Long-time, small type simulation actual environment evaluation technology (1) Aerodynamic heating field evaluation test (National Aerospace Laboratory, Science and Technology Agency) (2) High-speed rotation field evaluation test (National Aerospace Laboratory, Science and Technology Agency) 7) Large type actual environmental inspection technology (National Aerospace Laboratory, Science and Technology Agency)

4. Thermal Stress Relaxation Design of FGM

When the ceramics metal group FGM undergoes the high-temperature drops discussed above, the most fundamental problem is how thermal stress rupture can be prevented. Therefore, this project is named "Functionally Gradient Materials for Thermal Stress Relaxation."

Figure 4 shows a flow chart that depicts a series of analytical procedures. In the beginning, an attempt must be made to establish the right mix of the ceramic phase A and the metal phase B, the shapes, and dimensions of FGM, as well as the thermal boundary conditions. A typical example is FGM with a 2 h thick flat bar and a surface temperature defined as T_H on the ceramic side and T_L on the metal side. In addition, under thermal conditions the material is assumed to be in a steady state (see Figure 1). To determine the gradient of the material, a proper distribution factor must be discovered in order to define the gradient performance quantitatively.

Figure 5 shows an example of relatively simple distribution factors. Three parameters (z_A , z_B , and N) allow various compositions which are represented by the volumetric percentages of the two phases ($f_A(z)$ and $f_B(z)$) gradient profiles, to be expressed. Under these conditions, thermal conductivity and thermal stress must be analyzed to quantify the thermal stress distribution. Therefore, gradient values such as thermal conductivity λ , coefficient of thermal expansion α , and elastic constant (such as Young's module E and Poisson ratio ν) must be analyzed. Clearly, these physical values are dependent on the mixing percentage of ceramics and metals, that is, the composition ratio discussed above. In addition, these values tend to vary sharply with the

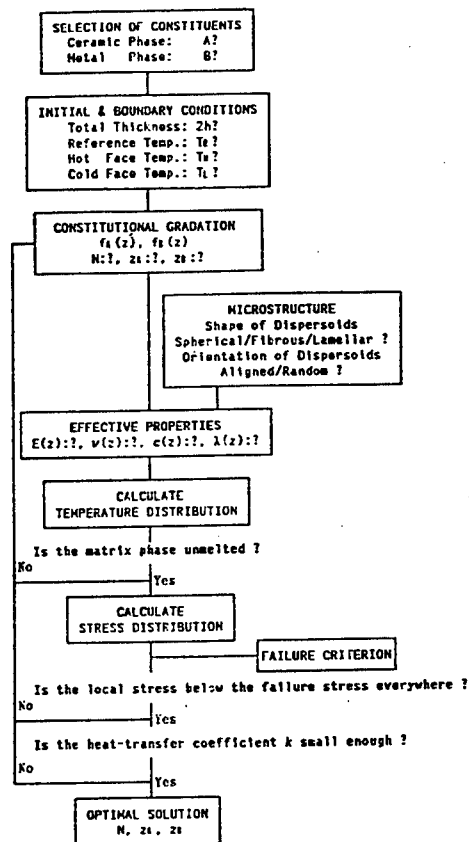

Figure 4. FGM Thermal Stress Relaxation Design Method

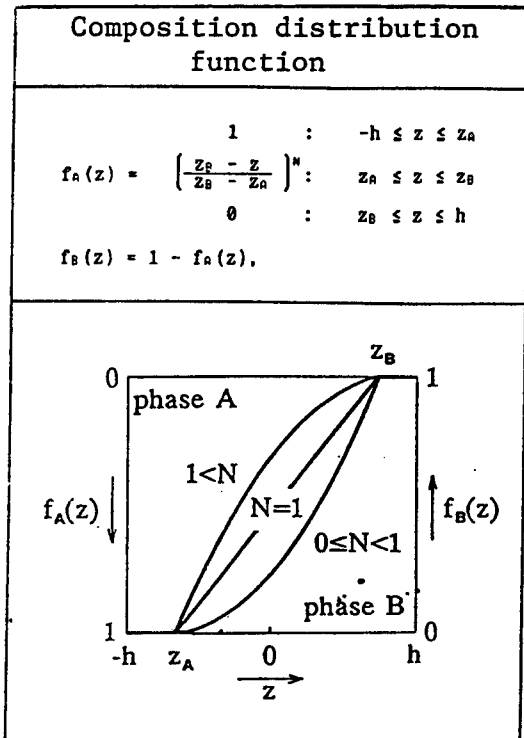

Figure 5. Distribution Function That States Composition Gradient of FGM

conditions of the microstructure of the mixing groups. Therefore, "the composite rules" for these physical values is important to the design of FGM.

The most popular composite rules that define these physical properties are called "phase addition average rule" and "harmonic average rule," respectively:

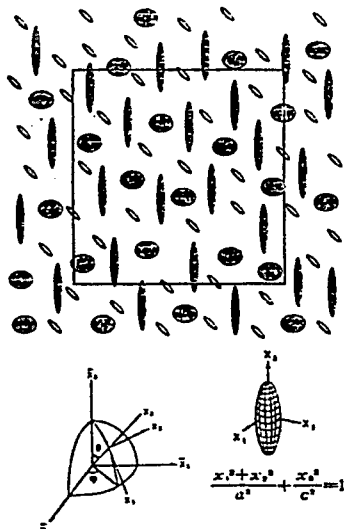

Figure 6. Microstructure for Multiphase Mixing Groups

$$P = f_A P_A + f_B P_B$$

$$1/P = f_A/P_A + f_B/P_B$$

However, these simple composite rules are available only for a specific microstructure. The authors have developed a microdynamic theory based on the microstructure model illustrated in Figure 6, specifically a variety of microstructures of the composite group materials, and formulated a method to calculate every physical property described above.²⁻⁴ The model is generally intended to cover multiphase group materials of $n + 1$ phase, including n type dissimilar materials, but the dispersion particles are treated as a rotary oval-shaped substance having a specified axial ratio, c/a in either case. In addition, their orientation is specified by the azimuth (θ , ϕ) of the rotary axis indicated in the figure. Therefore, non-sphere-shaped particles, which are needle-shaped (fibrous) or small sheet-shaped (flaky), are designed to focus on the effect of the orientation distribution as well. Furthermore, the physical properties of the particles may not necessarily be isotropic, allowing compliance with crystal particle-contained materials, such as carbon fibers or graphite flakes having marked anisotropy. It is also possible to treat the bores usually contained in a sintered body by bringing the physical properties of the particles to zero (or a proper value). In this article, the authors will show the composite rule for a two-phase mixing group, including sphere-like particles as the simplest example (see Figure 7).

As discussed above, if the distribution of the physical properties complies with the distribution of composition (and microstructure), then the equation of heat conductivity under a specified boundary condition needs to be solved. Since steady heat conductivity (specify both the front and back surface temperatures) is a simple unidimensional problem, the temperature distribution $T(z)$ in the thickness direction within the FGM material can be expressed by the numerical calculation in Figure 8. Furthermore, heat flux q as a standard of thermal insulation performance can be determined simultaneously.

Physical property calculation formula (sphere-like particle dispersion group)

$$\lambda(z) = f_a(z)\lambda_a + f_b(z)\lambda_b + f_a(z)f_b(z) \frac{\lambda_a - \lambda_b}{\frac{3}{(\lambda_b/\lambda_a) - 1} + f_a(z)}$$

$$\alpha(z) = f_a(z)\alpha_a + f_b(z)\alpha_b + f_a(z)f_b(z) \frac{(\alpha_a - \alpha_b)(K_a - K_b)}{f_a(z)K_a + f_b(z)K_b + \frac{3K_a K_b}{4G_a}}$$

$$K(z) = f_a(z)K_a + f_b(z)K_b + f_a(z)f_b(z) \frac{(K_a - K_b) \left(\frac{1}{K_a} - \frac{1}{K_b} \right)}{\frac{f_a(z)}{K_a} + \frac{f_b(z)}{K_b} + \frac{4G_a}{3K_a K_b}}$$

$$G(z) = f_a(z)G_a + f_b(z)G_b + f_a(z)f_b(z) \frac{(G_a - G_b) \left(\frac{1}{G_a} - \frac{1}{G_b} \right)}{\frac{f_a(z)}{G_a} + \frac{f_b(z)}{G_b} + \frac{1}{6G_a} \frac{9K_a + 8G_a}{K_a + 2G_a}}$$

$$E(z) = \frac{9K(z)G(z)}{3K(z) + G(z)}$$

$$\nu(z) = \frac{1}{2} \frac{3K(z) - 2G(z)}{3K(z) + G(z)}$$

(A: Matrix; B: Dispersion phase)

Figure 7. Physical Property Calculation Formula for Sphere-Like Particle Dispersion Two Phase Mixing Groups

Steady state temperature distribution and steady state thermal flux in the direction of thickness in terms of FGM flat bar

$$T(z) = T_H - q \int_{-h}^z \frac{d\zeta}{\lambda(\zeta)}$$

$$q = \frac{T_H - T_L}{\int_{-h}^h \frac{d\zeta}{\lambda(\zeta)}}$$

Figure 8. Steady State Temperature Distribution and Thermal Flux in the Direction of Thickness in Terms of FGM Flat Bar With the Temperature on the Front and Back Surfaces

In-plane elastic thermal stress in terms of FGM flat bar

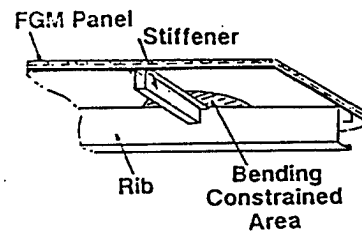
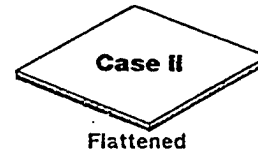

In case of free deformation (Case I)

$$\sigma_x = \sigma_y = E^*(z)[Az + B - \alpha(z)\Delta T(z)]$$

In case of out-plane deformation restriction (Case II)

$$\sigma_x = \sigma_y = E^*(z)[C - \alpha(z)\Delta T(z)]$$

$$E^*(z) = \frac{E(z)}{1 - \nu(z)}$$

$$A = \frac{I_1 J_0 - I_0 J_1}{(I_1)^2 - I_0 I_2}$$

$$B = \frac{I_1 J_1 - I_2 J_0}{(I_1)^2 - I_0 I_2}$$

$$C = \frac{J_0}{I_0}$$

$$[I_0, I_1, I_2] = \int_{-h}^h [1, z, z^2] E^*(z) dz$$

$$[J_0, J_1] = \int_{-h}^h [1, z] E^*(z) \alpha(z) \Delta T(z) dz$$

Figure 9. In-Plane Elastic Thermal Stress in Terms of FGM Flat Bar

Now, the authors will discuss how to analyze the thermal stress. The thermal stress analytical method may be largely classified into elastic analysis and nonelastic analysis. This article will examine a simple case of elastic analysis. If the thickness of the FGM flat bar treated above is sufficiently small compared with the width of the bar in the direction of x and y , the stress condition of the plane ($\sigma_z = \sigma_{yz} = \sigma_{zx} = \sigma_{xy} = 0$) can be postulated. Furthermore, the in-plane stress σ_x and σ_y are identical to each other and function only in the thickness direction, simplifying the questions. Figure 9 shows the results under the questions,⁵ which indicates one case when the FGM flat bar is entirely transformable without any dynamic restrictions (Case I) and another when the out-plane deformation (bar camber) is completely restricted (Case II). When the illustrated panel structure is considered, the portions fixed with a rib or a stiffener generally belong to Case II. On the other hand, when they are far from these restricted sections, their conditions are considered near to the Case II. In addition, the value $\Delta T(z)$ indicated in the expression generally stands for the temperature differentiation from the standard state (the stress is zero at the temperature $T_R(z)$), that is, $\Delta T(z) = T(z) - T_R(z)$.

From the above example, the reader can understand the steps in our analytical procedures. To further clarify our procedures, however, we will explain more concrete

numerical calculations in terms of the ZrO_2 -Ni group FGM.⁵ Figure 10 shows the physical properties required to analyze thermal conduction and thermal stress. Using the equation about the effective physical properties in Figure 7, we analyzed both thermal conductivity and thermal stress under the assumption that the FGM is a sphere-like particle distribution material in microstructure. When the relation between the matrix and the distributed particles are reversed in the ceramics phase and the metal phase, a different result is believed to be produced. In the case of a combination of ZrO_2 and Ni, the other effective physical properties, which exclude the thermal conductivity, conform to a simple phase addition average rule (linear mixing rule). To reach conformity, however, the two substances must not have markedly different values of Young's modulus.

Figure 11 shows the steady temperature distribution obtained by changing the parameter N for the composition functions illustrated in Figure 5 when using these physical properties and the elastic thermal stress distribution. When using a 3 mm thick flat bar as a test material, its 1 mm deep upper layer is assumed to be a functionally gradient material. Moreover, the surface temperature T_H is believed to be 1600 K on the metal side (ZrO_2), the temperature T_L is probably 800 K on the metal side (Ni), and the reference temperature is

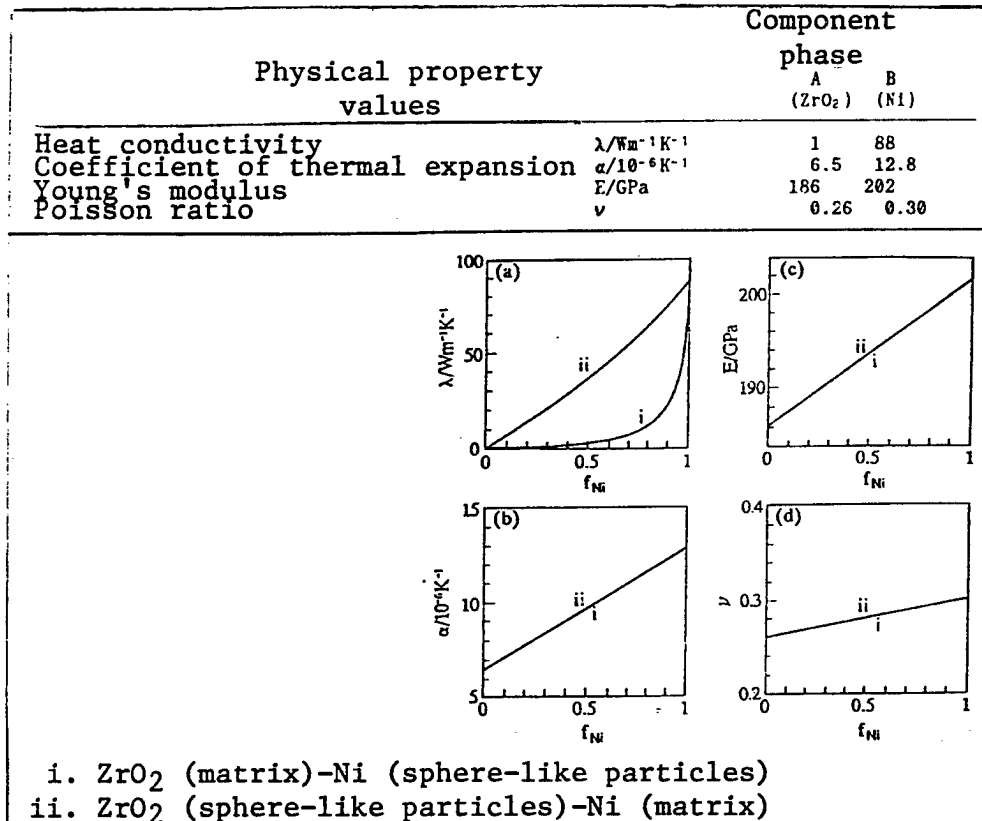

Figure 10. Input Data and Calculation Result of Physical Property Values for ZrO_2 -Ni Group

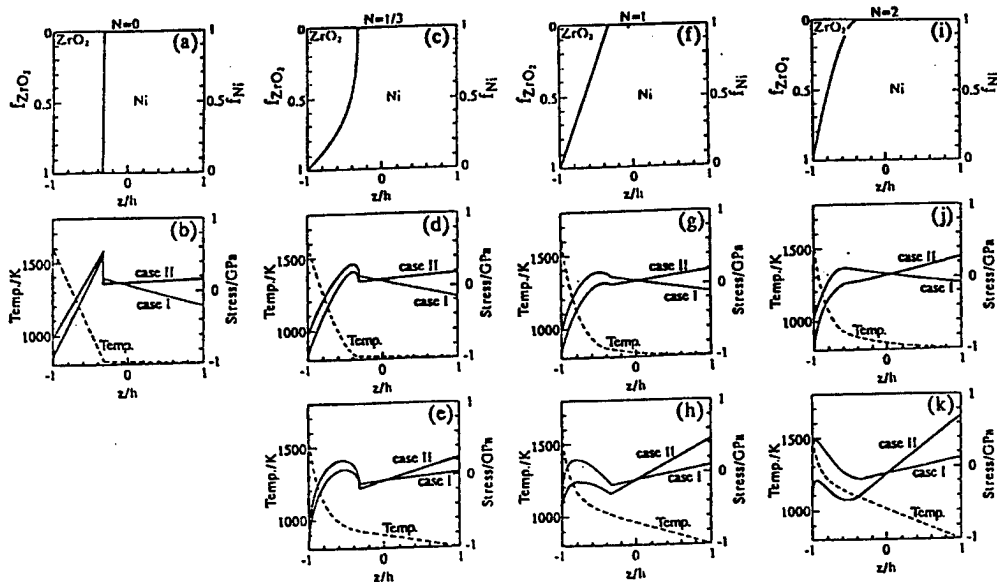

Figure 11. Example of Thermal Stress for ZrO_2 -Ni Group FGM (steady state elasticity analysis)

assumed to be 600 K. The value (a - b) indicated in Figure 5 resulted from a comparison made with a mere laminated material ($N = 0$). The stress in the ZrO_2 is under compression on the surface layer in this case, but the stress varies linearly as it moves deeper into the inward layer. As a result, a tension stress reaching about 500 MPa is produced near the interface. The ceramic materials generally are strong against compression but extremely weak against tension, producing an unfavorable thermal stress distribution. On the other hand, when a functionally gradient material is adopted for the surface layer, the thermal stress distribution varies with the parameter N , which depicts a composition gradient profile as illustrated, making it possible to place the thermal stress in the ZrO_2 rich layer under an excellent compression state

In this article, the authors have explained our basic approach to the thermal stress relaxation design of FGM through extremely simple examples. Currently, various details are under further consideration. For example, the thermal stress distribution thus obtained includes all thermal stress, given our definition. Therefore more importantly, through experiments to determine the stress breakdown of the metal and ceramic groups with various kinds of microstructures how "microscopic" thermal stress in the ceramic phase and metal phases is distributed must be quantified. Generally, the nonelastic effect induced by plastic deformation in the metal phase cannot be neglected. Therefore, an elastic and plastic analytical method must be developed to determine the effects. Furthermore, from the evaluation and tests carried out at various fields of temperature drops for each test piece, the analytical results should be compared and

reliability checked. The authors will discuss these subjects in this report if space is available.

5. Conclusion

In this report, the authors have discussed the outline of FGM, especially those associated with the ceramic and metal groups in order to focus on the thermal stress relaxation design that features the FGM. However, it is also very important for us to study how to synthesize and evaluate the FGM thus designed.

Our project has been trying to produce test materials based on the four types of preparations, which are largely classified into (1) vapor [see Table 2] deposition process, (2) particle process, (3) flame spray process, and (4) self-heat [see Table 2] reactive process. Table 2 shows the various FGM test materials that comprise ceramic/metal groups, ceramic/intermetallic compounds, or ceramic to ceramic groups. The thermal insulation performances of the test materials are being studied and evaluated based on the application of a small thermal impact test unit induced by laser beam irradiation or a high-temperature drop site basic evaluation test unit using an xenon arc lamp indicated in Figure 12, and an actual environment test unit based on high-temperature and high-pressure gas flow. The SiC coating is very likely to enhance the acid resistance performance of a high-temperature structural material designed for aviation and space, which is especially true for the C/C composites currently highlighted. Furthermore, high expectation is given to the development of C/(C-SiC) group FGM based on chemical vapor infiltration (CVI). At the same time, the conventional thermal barrier coating (TBC) technology is a new development based on the flame spraying process by introducing a new FGM layer.

Table 2. FGM Groups Based on Various Composite Processes (Test Pieces)

Vapor deposition process	(PVD) (CVD)	TiC \leftrightarrow Ti, TiN \leftrightarrow Ti, CrN \leftrightarrow Cr SiC \leftrightarrow C, TiC \leftrightarrow C
	(PVD/CVD)	(SiC \leftrightarrow C) (C/C) (TiC \leftrightarrow Ti)
	(CVD/CVI)	[SiC \leftrightarrow (C+SiC)][(C/SiC) \leftrightarrow (C/C)] [SiC \leftrightarrow (TiC+SiC)][(C/TiC) \leftrightarrow (C/C)]
Particle process	ZrO ₂ \leftrightarrow Ni, ZrO ₂ \leftrightarrow SUS304 ZrO ₂ \leftrightarrow Ti, ZrO ₂ \leftrightarrow W, ZrO ₂ \leftrightarrow Mo	
Flame spray process	ZrO ₂ \leftrightarrow Ni, ZrO ₂ \leftrightarrow NiCr	
Self-heat generation reactive process	TiB ₂ \leftrightarrow Ni, TiC \leftrightarrow Ni, TiB ₂ \leftrightarrow Cu MoSi ₂ \leftrightarrow TiAl, (MoSi ₂ +SiC) \leftrightarrow TiAl	

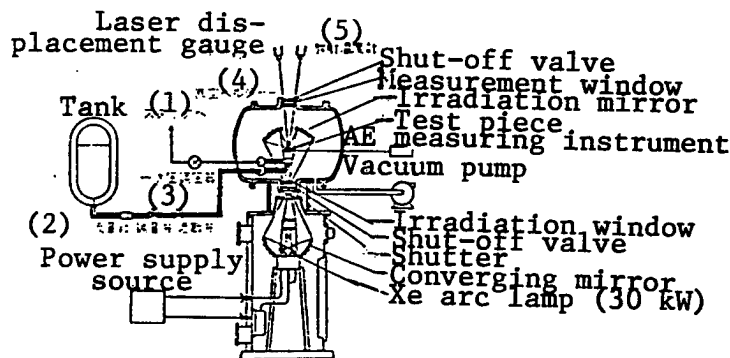

Figure 12. High-Temperature Head Drop Field Basic Evaluation Testing Equipment

Key:—1. To stack—2. Flow meter control valve/shut-off valve—3. [illegible]—4. Vacuum Bell Jar—5. Radiation thermometer

References

1. 1986 Scientific Technology Promotion Adjustment Funds "Investigation Into More Complex-Induced Function Development and Basic Technology About Thermal Stress Relaxation" Report (1987).
2. K. Wakashima and T. Mori, Constitutive Relations and Their Physical Basis, p 543, RISO National Laboratory, Roskilde, Denmark (1987).
3. Kenji Wakashima, A Collection of Theses in Memory of 50th Foundation Anniversary of Precision Engineering Research Institute of Tokyo Industrial University, p 19 (1990).
4. K. Wakashima and T. Tsukamoto, Proc. of FGM's 90, p 19 (1990).
5. K. Wakashima, T. Hirano, and M. Niino, Proc. of ESA Sympos. on Space Application of Advanced Structural Materials, ESTEC, Noordwijk, The Netherlands, still in process (1990).

**Japan: Toshiba Coporation Introduces New
1-Megabit SRAM Chips**

*OW0611085491 Tokyo KYODO in English 0650 GMT
6 Nov 91*

[Text] Tokyo, Nov. 6 (KYODO)—Toshiba Corp. announced Wednesday it will introduce three families of 1-megabit static random access memory (SRAM) chips in the domestic and overseas markets.

The new SRAMS feature access times of 12, 15, and 20 nanoseconds and blend two widely used chip technologies—complementary metal oxide semiconductor (CMOS) and bipolar—onto a single silicon wafer, company officials said. A nanosecond is a billionth of a

second. The 12, 15, and 20 nanosecond devices are available in single outline j-lead (SOJ) packages from Wednesday and are priced at \$320, \$230, and \$160 respectively.

Toshiba will begin shipments of the three bipolar CMOS SRAMS, designed as dual inline packages (DIPS), early next month at the same prices, the officials said. The company plans to produce about 30,000 chips a month from January 1992.

SRAMS are widely used in powerful workstations, mini-computers, and supercomputers as cache memories and buffer memories to boost the performance of the central processing unit.

Fuel Cell Power Plant Near Commercialization

91FE0734A Tokyo TSUSAN JANARU in Japanese
May 91 pp 58-60

[Article by Waku Yamagiwa of the Nihon Keizai Shimbun Company's editorial committee: "Almost-Practically-Useful Fuel Cells Highlighted in Policies Promoting Energy Conservation"]

[Text]

Fuel Cell Power Plant Highlighted in Policies Promoting Energy Conservation

Fuel Cells Almost Ready For Practical Use

The development of fuel cells, which are by far more energy-efficient and clean than thermal power, is progressing at a fevered pitch. These characteristics of fuel cells perfectly fit the energy conservation policies that MITI is promoting. For manufacturers who have been pushing forward with R&D for close to ten years, it also marks the arrival of great business opportunities.

In comparison with conventional electric power generators, fuel cells have the following features: 1) they generate hardly any air pollutants such as oxides of nitrogen (NO_x) or oxides of sulfur (NO_x); 2) their power efficiency is high—more than 40%; 3) if their waste heat is used in thermoelectric supply (cogeneration) systems, the overall energy efficiency rises to about 80 percent. It is widely anticipated that fuel cells for commercial use will emerge in one to two years.

Fuel cells are devices that produce electrical power by a chemical reaction that occurs within them; the reaction is the reverse of water electrolysis. Fuel cells produce hydrogen and carbon monoxide from substances that are normally used as fuel, e.g., natural gas, and then use these as reaction gases.

Conventional systems, in which fuel is burned in order to run a generator, lose a great deal of energy and emit oxides of nitrogen, oxides of sulfur, and other such pollutants. Fuel cells directly generate electricity by a chemical reaction, so their efficiency is high and there are few worries about pollution, vibration, and noise. After they were put to practical use in 1965 as the power supplies for U.S. spacecraft, the development of fuel cells for commercial use has been thriving in many countries.

There are three types of fuel cells that differ according to the type of electrolytic chamber in which the gases flow: the phosphate type (first generation), the fused carbonate type (second generation), and the solid electrolyte type (third generation). Progress is being made in the development of even more advanced generations of fuel cells; the first generation is just about ready for practical use.

The Moonlight Project started by MITI and the national research institutes has led the development of fuel cells

in Japan. In 1981 they adopted it as a priority development item. Electric power and gas companies participated in the development work and tackled the first generation of phosphate fuel cells. United Technologies, a U.S. company, had been advancing in this field, but in 1984 it joined with Toshiba to form a company called IFC (International Fuel Cell). Given the competition between domestically-produced fuel cells and fuel cells made by IFC, experimental phosphate fuel cell plants are being built one after another in Japan, and the results of their operation are accumulating.

The Energy Conservation Section of MITI's Industrial Technology Council gave its assessment in a report it compiled in May 1989: "The basic technology for phosphate fuel cells has been established." Although there are various themes in the Moonlight Project in addition to new energies and fuel technologies, e.g., the development of super-high-pressure turbines, energy storage based on flywheels, etc., we can apparently say that fuel cells are a representative example of development that progressed smoothly.

The uses of phosphate fuel cells are roughly divided into two areas. One use is in large-scale power plants that are substitutes for thermal power generation. The other is private, high-efficiency power generation in which cogeneration is combined with the fuel cells: The fuel cells are set up on-site (fixed placement) in office buildings and other large facilities. Although the basic technology for both of these has been established, the final stages remain, demonstrating their operational performance, making them smaller, bringing their cost down, etc.

As for the use of phosphate fuel cells in power plants, in addition to the construction of two megawatt-class plants with the Moonlight Project, Toshiba and Tokyo Electric Power built an 11-megawatt plant and are now running it through tests. Also, although it is small in scale, Okinawa Electric Power completed a 200-kw facility on the island of Watahashiki in the fall of 1989; they are experimenting with methanol for the fuel used.

As for the use of on-site phosphate fuel cells, there is certainly a crush of demonstration tests. The already started Tokyo Gas (50-kw and 100-kw facilities), and Kansai Electric Power and Osaka Gas (200-kw facilities) are typical examples. The positive stance of gas companies is particularly noticeable. In the future Toho Gas will procure one and Tokyo Gas and Osaka Gas will each procure ten middle-scale fuel cells from IFC and will test them in hotels and other large buildings. Nippon Oil, IFC, Nippon Mining, Toyo Engineering, and Sanyo Electric started demonstration tests on phosphate fuel cells that use naphtha. These companies are aiming for on-site fuels that are oriented towards petroleum refineries and chemical plants.

The performance of both power-plant-use and on-site-use phosphate fuel cells is at the stage where the fuel cells will at least pass future demonstration tests. The

focus is on how much cost can be brought down. The manufacturers estimate that the costs of building phosphate fuel cells will be ¥ 300,000/kw when ten fuel cells for power plants are produced yearly, and ¥ 250,000/kw when a hundred fuel cells for on-site use are produced yearly. Taking into account the merits of low pollution and high efficiency, the difficulty in finding sites for new electric power plants, and so forth, if phosphate fuel cells could be mass-produced to a certain extent, it seems that they could compete pretty well with conventional power generation systems.

Major Makers Also Desire the Business

The major makers of fuel cells already started running after the business. Fujitsu Electric is the most enthusiastic about the phosphate fuel cell business. Three municipal gas companies—Tokyo Gas, Osaka Gas, and Toho Gas—have already embarked on the joint development of fuel cells for commercial use. Fujitsu Electric's target is to sell phosphate fuel cells with outputs ranging from 50 to 100 kw in 1993. If it can get 500 orders per year, it thinks that it can bring the cost down to ¥ 250,000/kw, so it is starting to build a mass-production line at its Chiba plant. Toshiba will start

producing 200-kw-class phosphate fuel cells in Japan starting in 1992. In addition, Toshiba will provide ¥ 10 billion to IFC to support the development of megawatt-class phosphate fuel cells for on-site use.

Phosphate fuel cells will certainly be the first type of commercial fuel cell. However, when compared with succeeding generations, there is one point on which phosphate fuel cells compare poorly: the temperature of their waste heat is low. The temperature of phosphate fuel cells' waste heat ranges from 150 to 200 °C. It is not that they cannot be used in cogeneration, but utilization of their heat is confined to small-scale use such as supplying hot water.

In comparison with phosphate fuel cells, fused carbonate fuel cells and solid electrolyte fuel cells are just developing, but they have potential. With each higher generation the waste heat temperature gets higher, and power generating efficiency also improves. If these types of fuel cells are used as the core equipment of a cogeneration system, the heat can actually be utilized, e.g., it can be used to heat buildings; also, by putting them in power plants, power generating efficiency is said to then be 50%. We can also expect "very-high standards" of power generating efficiency.

Table 1. State of Major Japanese Firms' and Laboratories' Development of Solid Electrolyte Fuel Cells

Name of organization	State of affairs
Tokyo Electric Power Electric Power Development Corp Mitsubishi Heavy Industries	Cylindrical-type 1-kw-class; completed trial operations Mitsubishi Heavy Industries also testing plate-type.
Kansai Electric Power Tokyo Gas Osaka Gas	Cylindrical-type, 25-kw-class; trial operations. Tokyo Gas also testing plate-type
Toa Nenryo Kogyo	Achieved 200 watts with plate-type.
CRIEPI	Basic research on cell structure and materials for both cylindrical-type and plate-type.
NEDO	Fujitsu Electric Research Lab, NKK, Fujikura Electric Lines, Sanyo Electric, Murata Mfg, Energy Engineering Research Institute commissioned to develop elemental technologies.
Electronic Technology Research Institute Chemical Technology Research Institute	Achieved 500 watts with cylindrical-type starting research on elemental technology for plate-type.

Nevertheless, putting these other two types of fuel cells to practical use will apparently take time. That is because topics of technical concern are numerous: With fused carbonate fuel cells, the development of electrode materials that resist corrosion holds the key to their practical use; with solid electrolyte fuel cells, the key is materials that can be used at high temperatures and gas charging technology.

NEDO (New Energy Development Organization) commissioned Hitachi Ltd to develop the second generation of fused carbonate fuel cells. In April 1990 people involved in NEDO proudly announced that they "achieved the highest output of electrical power in the world," but the output was confined to 26 kw. In addition to this, the output is small but Ichikawajima Harima Heavy Industries succeeded in 2,300 hours of

continuous operation of 2-kw-class fused carbonate fuel cells. The Fused Carbonate Fuel Cell Development Systems and Technology Research Union succeeded in 1,000 hours of continuous operation of 11-kw-class cells. Both of these efforts are part of the Moonlight Project. As for solid electrolyte fuel cells, the Electronic Technology Research Institute and the Chemical Technology Research Institute are in charge of their development.

The output of third-generation solid electrolyte fuel cells is a size smaller. The output of the fuel cell that Mitsubishi Heavy Industries, who boasts of having the most advanced solid electrolyte fuel cell technology in Japan, joined forces with Tokyo Electric Power and the Electric Power Development Corporation to develop is one kilowatt. In solid electrolyte fuel cells, Westinghouse, a U.S. company, is leading the world: it achieves 5,000 hours of

Table 2. Varieties of Fuel Cells

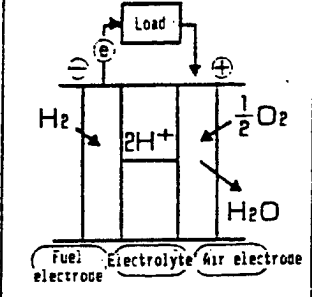
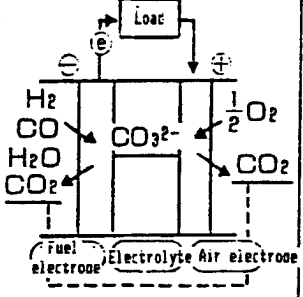
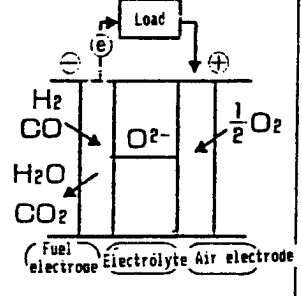
	Phosphate Fuel Cells (PAFC)	Fused Carbonate Fuel Cells (MCFC)	Solid Electrolyte Fuel Cells (SOFC)
Electrolyte	Phosphate-water solution	Lithium carbonate Potassium carbonate	Zirconia ceramic
Charge carrier	H^+	CO_3^{2-}	O^{2-}
Operating temp.	200°C	650°C	1000°C
Reaction gas	H_2	H_2, CO	H_2, CO
Fuels	Natural Gas, methanol, naphtha	Natural Gas, coal gas, methanol	Natural Gas, coal gas, methanol
Electrode materials	Mainly carbon	Nickel, stainless steel, etc.	Nickel, etc.
Catalyst	Platinum	The nickel of the electrode	Not needed
Power efficiency	40~50%	45~60%	50~60%
Main uses	On-site, power plants	Power plants	On-site, power plants
Features	Closest to practical use	high power efficiency	high power efficiency
Principle of operation			

continuous operation with 3-kw-class fuel cells. With these results from Mitsubishi Heavy Industries, we can say that it is catching up with Westinghouse.

Westinghouse has the patent on "cylindrical" electrodes, so in order to get around this the Japanese posture is to emphasize the development of plate-type electrodes. Despite the fact that it is cooperating with Westinghouse, Tokyo Gas started independently developing plate-type electrodes. Toa Nenryo Kogyo also produced an experimental version of a 200-watt-class plate-type-electrode. Although there is a possibility that plate-type-electrode solid electrolyte fuel cells can output more power per unit volume than the cylindrical types, finding out how effective they are is waiting for future evaluations. For the time being it looks like the competition between Japanese and Westinghouse technology will continue.

'How To Popularize Fuels Cells'—The Issue At Hand

At the earliest, the practical utilization of second- and third-generation fuel cells is seen as happening around the year 2000. The issue now is the importance of popularizing first-generation phosphate fuel cells, especially those for on-site use. We can expect mass production to lower the costs of on-site phosphate fuel cells more so than with those for use in power plants. If on-site phosphate fuel cells get popular, they will be a big contribution to energy conservation throughout society.

If the foundation is laid for distributed power by means of phosphate fuel cells, and if they are replaced when solid electrolyte fuel cells are complete, then the alternation of generations should proceed without any problems.

When there were attempts to push distributed power generation by means of these on-site fuel cells, the regulations of the regime, such as the Electric Enterprises Act, became like leg irons. In raising the efficacy of on-site fuel cells, it is desirable to have fuel cells connected to the distribution lines of electric power companies and then using those connections effectively by exchanging power back and forth. At the present stage, however, in addition to the technical problem of higher harmonics flowing back to the power system, the concerns of electric power companies are also twisted, so connections between fuel cells and distribution lines are not recognized. Nevertheless, connecting fuel cells with distribution lines is an issue that should be immediately solved.

In June 1990 the Supply and Demand Group of the Electric Enterprises Council, which is an inquiry group within MITI, compiled its long-term forecasts of electric power supply and demand. These long-term forecasts became the basic materials for the alternative energy supply goals that the government decided upon in

October 1990. In those materials it is predicted that by the year 2010 fuel cells will account for more than 5,000 megawatts.

Also, it is predicted that there will be a ¥10-trillion market in 2000 and the total output will be 35,000 megawatts. Companies and electrical manufacturers who are aiming for new business as well as electric power companies are active in the development of fuel cells. The enthusiasm of the private sector is linked to the Moonlight Project. The role of the national project is already over on the technological side of phosphate fuel cells. From now on there will be a need for administrative skills that are oriented towards the spread of fuel cells, e.g., ironing out the advantages and disadvantages with electric power companies, appropriate easing of regulations, etc.

MITI To Increase Electric Power by 5,000MW in Next Two Years

*91FE0734B Tokyo GENSHIRYOKU SANGYO
SHIMBUN in Japanese 2 May 91 p 1*

[Text] On 26 April MITI made public its summary of an electric power facilities plan for FY1991 that was submitted by electric power businessmen from throughout Japan (a total of 66 individuals, twelve electric power companies). According to that summary Japan's maximum power demand in FY2000 is predicted to be 178,840 MW (average annual increase, 3.1 percent). In order to meet that demand, MITI will submit to the Power Development Council a bill to have within two years a total of 171,660 MW—5,240 MW from five nuclear power plants; 5,610 MW from 38 thermal power plants; 2,810 MW from 36 hydroelectric power plants.

In this plan the prediction is that the total demand for electric energy in FY2000 will be 955.2 trillion KWH (average annual increase, 2.7%). The average annual increase is along the lines of the long-term energy supply and demand forecast that was compiled the year before, and is a 0.1% downward revision from the last forecast.

As for the demand for electric energy, this plan projects a steady increase, given the domestic-consumption-led favorable economic climate. The average increase in regular consumers' demand for electrical energy is estimated to be 4 percent because of the following factors: the spread and expanded use of heating equipment, such as air conditioners; the larger size of household appliances due to changing lifestyles and the inclination towards amenities; and more office automation. Commercial use of electrical energy is predicted to increase 1.6%; the smallness of the forecast is attributable to the anticipated effects of electrical energy conservation.

As for maximum demand, in FY90 it was an increase to a two-figure level of 12.1%, reflecting the favorable industrial demand and the record-breaking heat. For the next decade the average rate of increase is predicted to be the same as before, 3.1%. The annual load factor is tending to decrease moderately over the years because of the increase in air conditioning and so forth; this trend is seen as continuing in the future. Thus the necessity of load levelling measures are emphasized.

In order to cope with this demand, MITI thinks that it is necessary to continue developing electric power resources so that by FY2000 Japan will have a total of 65,180 MW: 8,910 MW from hydroelectric power; 37,190 MW from thermal power (coal-fired power, 17,560 MW; LNG-fired power, 19,390 MW, etc.); and 19,080 MW from nuclear power.

MITI forecasts that at the end of FY2000 hydroelectric power will account for 18.9% of electrical power resources; thermal power, 60.1%; and nuclear power, 21%.

For these reasons MITI is submitting to the Power Development Council a bill concerning the development of electrical power resources. This involves 2,690 MW of hydroelectric power, 2,430 MW of thermal power, and 620 MW of nuclear power, which totals 5,730 MW (35 plants), in FY91; and in FY92, 120 MW of hydroelectric power, 7,180 MW of thermal power, and 4,630 MW of nuclear power, which totals 11,930 MW (44 plants).

Intelligent Manufacturing System (IMS)

916C3811A Tokyo BULLETIN OF THE INSTITUTE OF PRECISION ENGINEERS in Japanese Vol 57 No 1 1991 pp 43-49

[Article by Hiroyuki Yoshikawa, professor, Faculty of Engineering, University of Tokyo]

[Excerpt][passage omitted]

2. Burgeoning Technonationalism

When consideration is given to the current situation in Japan, Japan has managed to, along the course of history described briefly above, steer itself along down the road to the modern task—flexible manufacturing. What is meant by flexible manufacturing is a mode of manufacturing where production is undertaken after the existing consumer demands have been accurately grasped, and we are now in an age in which flexible manufacturing can ensure an edge in terms of market share and competition. Japan has lots of technology. Aside from the key technologies such as FMS and robotics, all of which are based on machinery technology, Japan also possesses expertise in the techniques of production management, such as TQC focusing on QC. Further, the production management methods, such as the just-in-time inventory system and the recent concurrent engineering, all originated in Japan. Large amounts of expertise concerning manufacturing, such as the management methods not only involving machine systems, but also workers, are concentrated in Japan. As common sense goes, Japan is said to be a huge center of excellence as far as manufacturing is concerned. Take a look at reality, and the Japanese market shares are expanding rapidly; automobiles are expanding their market share and the share of electronic products is close to 100 percent. However, these pictures are the results of pressure that has been applied in connection with the Anti-Monopoly Law. If the market were liberal in the true sense of the word, the greater part of it could be cornered by the Japanese. But, can that be permitted to occur? I do not think so. If such a monopoly were permitted, the result would not only be the loss of employment in other countries, but it would also damage the industry in those countries. A victory for one party means a defeat for the other, and for better or worse, some people would be plunged into misery.

The idea of technonationalism was born out of the desire to prevent such misery from falling onto one's head, and the concept has given rise to many ramifications: one theory proposes the erection of trade barriers, while another is an attempt to expand the range of interpretation of ideas that are so trifling that they would stand no chance of winning patent rights at this point in order to prevent, for example, the importation of products incorporating those ideas. The result would be that each country would be doing its best to tie itself up with legalistic protective nets in an effort to contain disadvantages as much as possible. This concept is termed technonationalism, and what triggered the spread of technonationalism worldwide was Japan's success in

becoming the center of excellence in manufacturing. I am wondering if Japan might not have caused a fissure to be generated in the fabric of the so-called Western economies. Since Japan more than any other country relies heavily on the world market, if technonationalism were to take hold, Japan would sink. Japan will have no one but itself to blame.

Here, let's turn the discussion to why the world will go the route of technonationalism. I did not mention anything about this in the brief history above. It is that throughout the course of evolution in manufacturing, from the human-wave tactics to volume production to flexible manufacturing, the volume production systems are still alive and healthy and the total productive capacity of these systems is extremely large. Suppose all the auto-manufacturing lines in the world started operating at full capacity—the output would probably far surpass the demand. Now is the time when the latent capacity of manufacturing lines has become larger than the capacity of the consumers to consume the products rolling off those lines. This is the essence of the problem and, in the case of Japan, we, i.e., the engineers belonging to the Institute of Precision Engineers, are to blame for plunging our country into the dilemma. The intent was good, but the results have proven to be clumsy. What went awry? Being engineers, we can hardly say that technology is to blame, because turning back the progress of technology would lead to the demise of mankind. The conclusion is that we can not help but think that the fault may lie with the mechanism of what we call the Western economies. This is the concept underlying our proposal for the intelligent manufacturing system, or IMS.

3. Definition of IMS

Broadly speaking, the definition of IMS has two sides. One is our call to the world, "Isn't it time for all the people of the world, as a whole, to commit themselves to mulling over the manufacturing systems of the 21st century, such as CIMS?" Inherent in this project, of course, are manufacturing systems as technological frontiers, and it proposes coming up with the concept for an ideal futuristic manufacturing system that will probably be an amalgamation of information technology and machine technology, possibly including control technology, thus creating a pilot system. Participation in this effort is currently limited to the organizations paying membership fees, and among those showing interest are corporations, universities and research institutes. To determine the objects of interest for the Japanese, we solicited preliminary proposals, the number of which surpassed 100. All proposals were highly constructive, which seems to show the respondents' positive interest in the significance of carrying out research on manufacturing technology as an international collaborative project.

The other involves our attempt to establish, through the project, an academic system for manufacturing engineering. Earlier I said that the Institute of Precision Engineers was to blame, but what strikes me when

hearing the fire of criticism being directed at Japan, such as in the Japan-U.S. Structural Impediments Initiative, is that Americans and Europeans have an innate feeling that the Japanese are profiting by unfair means. On the other hand, Japan is promoting the great principle of a liberalized economy and says, "Our excellent technology is used to turning out quality goods which, in turn, benefit the consumer. The result is that profits are rolling into Japan. What is wrong with that?" The Japanese further counter, "Telling the people not to buy Japanese products is socialism. Everyone knows that socialism has failed, so it is self-contradicting." A careful look into the problem, however, will reveal that the issue is not so clear-cut and simple, nor is the ground on which the assertion of "not being unfair" is founded so decisive. There are probably many problems, but I would like to point out two of them here.

We have been reaping the benefits of the mechanism termed a liberalized economy, and this would have been impossible if we had had to have lived through socialism. Then, who on earth developed the liberalized economy in the first place? It was none other than the United States and Europe. Basically, it was Europe. War had to be fought and blood had to flow in the course of the development of the economic order. As for the Utopia, i.e., the liberalized economy, obtained after so much trouble, it has been maintained in peace. We must not overlook the immense historical cost of the system. We will then discover that Japan has not paid any of the cost of upholding the economic order. Although the cost of upholding a mechanism cannot be expressed in economics, to be sure, a bitter taste would linger that "Well, we were in a Sumo match in a ring that we had built after so much toil and cost, according to our own rules; some funny guy clambered into the ring and took away not only a victory, but also our precious prizes." It may only be natural that those people should demand, "You should pay the cost of the ring and participation." Japan has paid very little in terms of historical contributions, as described above. Take the collapse of Eastern Europe, for example, and liberalism has come to permeate every corner of the earth as a result. The great political confrontation between East and West, that is, socialism vs. liberalism, has ended in the victory of liberalism and the ideology has come to cover the entire world, but the costs that were paid before the drama came to an end were also immense. The defense cost was the cost that had to be paid to prove that "liberalism had ultimately been proven right." So, in the first place, Japan's contribution to the cost has been very small.

In the second place, a matter of great relevance to the Institute of Precision Engineers and to us, the researchers, is that when the field is limited to competitive technology and manufacturing engineering, exceedingly higher portions of the manufacturing engineering knowledge are being concentrated in Japan. The result is that products made in Japan are selling briskly. I am convinced that knowledge invites riches and that the society in which we now live is entering the age of

knowledge equals wealth. The days are over when wealth could be obtained through usurption by winning a war, and now is the time when industry brings profits. What this means is that the principle "One who accumulates industrial knowledge begets wealth" has gained timeliness. Even allowing for the imbalances among the advanced industrial nations, too much of the manufacturing knowledge is concentrated in Japan. The result is that products made in Japan are hard pressed to meet their demand. The gravity of the problem lies not so much in the fact that the current state of affairs is full of contradictions as in the fact that those contradictions have an inherent tendency to aggravate. Money keeps flowing into Japan. The result is that if one initiates research on the development of a product, it will be on the market three years later. Large amounts of money are being invested in the development of manufacturing technology, which expedites the speed of technical innovation. Profits invite technical innovations, increasing still further the concentration of knowledge in Japan. The competitive power of Japan will keep on increasing into the future. The distribution of knowledge in the world will become still more uneven, increasing the tendency toward positive feedback.

4. Problems of Diffusion of Manufacturing Technology

An example of what the epithet "the larger the amount of knowledge, the wealthier" means in economic terms is that the imbalances in living standards will increase even further. This is not good. So what causes this?

Knowledge has two attributes, i.e., innovation and diffusion. Such activities as knowledge finding its way into some other area and presenting one's research paper at an academic meeting belong to the category of diffusion. However, I am afraid that the speed with which manufacturing technology diffuses is extremely slow. This is an exception, but in the field of physics, such as in superconductivity, an invention by a physicist is relayed by facsimile all over the world on the same day the invention is made. The rush is to stake a claim to priority. As such, diffusion, or the speed of expansion, in natural sciences is exceedingly high. On the other hand, the manufacturing technology of an auto plant will hardly flow out of the compound. People from foreign countries visit auto plants and marvel at their efficiency, but I doubt how many, if any, of them have managed to grasp the real technology of the plant. A letter arrives a month later saying, "It was superb, but I have trouble understanding what it was all about." Transfers occur only rarely. There are several reasons for manufacturing technology finding it so difficult to diffuse, but permit me to dwell on the issue of diffusion a little longer. The diffusion speed within a corporation is very fast. A new technology developed by a division of a corporation will soon spread to the corporation's other divisions, but between different corporations the speed with which a technological discovery will diffuse will be very slow. This is especially so when the two corporations are in different categories of industry. Between countries the

diffusion speed will be much slower. Take the North-East relationship, and the prospects are hopelessly low, being close to zero. As seen above, the diffusion mechanisms of manufacturing technology on earth take various forms and, at the same time, harbor extremely large impedances.

Broadly speaking, there are two reasons for all of this: One reason is that the secrecy of manufacturing technology is internationally sanctioned as a means of maintaining competitive power, and hence the rule is to "cover the manufacturing technology with a veil of secrecy, but keep marketing the products based on the technology." In its pure form, the liberalized economy has been none other than an "economy to freely market products." On the other hand, however, there exists the recognition that a negative attitude alone will not lead to a prosperous economy, and that there should be some levels of diffusion of the technology, and this thinking is reflected in corporate advances abroad. Going overseas is the only avenue open for making manufacturing technology available to the local people. The speed of diffusion, however, is slow. Diffusion has not gone beyond the levels of practice: "Making the Americans stand up in an instructional meeting before getting to work and attiring them in the same work uniforms have led to increased productivity," although none such practices are part of the American culture. If technology can be diffused only through the distortion or destruction of the culture, I think that there is something wrong with it.

As I consider the reasons for the slow diffusion, the first is that manufacturing engineering has yet to be systematized as physics is. The second is the problem of language. Technology is closely related to the people's way of living. Hence, a difference in languages represents a big barrier. The Japanese have a culture specific to them, such as shying away from stating their ideas and instead expecting the results to prove themselves. The world of engineers is devoid of the culture that characterizes the world of physics—the willingness to openly discuss. All these reasons are acting in concert to slow down the diffusion of manufacturing technology. However, within the same corporation, the same culture and language prevail and no legal restrictions exist (regarding the spread of manufacturing technology). Moreover, Japanese companies are strongly bound by a sense of "our company bound together by common fate," so the speed with which technical knowledge diffuses throughout the company is very fast, which makes a good contrast (with the slow speed with which technical knowledge flows between countries).

Here, the opportunity presents itself for researchers to find a way out of the impasse. If the problems involved are legalistic alone, they should be left to lawyers for resolution. However, if the diffusion of manufacturing technology has failed to materialize because the technology has yet to be systematized, who will systematize it? The job falls to engineers and researchers.

5. Formulating a System of Manufacturing Technology As a Science

Delving a little deeper into history, let's now consider how technology has been established. Some technologies diffuse much more readily than others. Some, like mechanical engineering and electric circuitry theory, are taught openly at universities. If you want to learn something about those technologies, all you have to do is go over to the bookstore and buy a book on the subject. These represent knowledge that has an extremely high rate of diffusion. As for manufacturing technology, no textbook has ever been successful in describing and elaborating on the technology systematically, in the true meaning of the word, and in a manner that will induce the diffusion of the knowledge. Take the water wheel, for example. It has a history of several centuries, dating back to Mesopotamia. Students of hydromechanics appeared in the 18th century, and they conducted systematic studies on water wheels. Hydromechanics was established as a science during the period from the 18th to the 19th century. No researchers have ever confined themselves inside their laboratories to mull over what hydromechanics is. The many years of fierce competition in the water wheel industry led to the best of the best water wheels taking root. The developmental process was then extracted and systematized as a science. The result was the debut of hydromechanics as a science. This was the Western way. What this kind of approach has generated is that the basics of the technology are shared among the people, as is mechanical engineering. During the period from the 18th to the 19th century, they recorded various technologies that had evolved from medieval times through the Industrial Revolution in textbooks. Take the people who are teaching mechanical engineering and electrical engineering in Japan—some have written their own textbooks, but the basics of their textbooks were all established by foreigners. There are no textbooks whose origins can be traced to a Japanese, and this represents a big problem. Maintaining scientific records in textbooks must have been a much more costly enterprise than preparing the sumo ring described above. Although it is a kind of cost that does not show up in any economic theory, efforts have been made to record the technology achieved in industry in textbooks and convey it to the next generation. The effort will require manpower and will demand that research be conducted one way or another. Since the task of systematization is being done at great cost in universities, the social cost will be very high. I am afraid we Japanese have been too negligent in this respect.

One school of thought has it that those research tasks which are expected to prove useful for future industry, but the usefulness of which is considered to be quite uncertain, should be promoted as public research. This kind of research task has been termed precompetitive knowledge or precompetitive technology. However, after a certain period of time, the precompetitive technology transforms itself into competitive technology, is used for manufacturing products, and the products compete in the world market. Once the product has gone through its

life cycle, the technology will also have fulfilled its mission, and a matter of critical importance is what will become of the technology then. Corporations which have successfully developed best-selling products often cite technology as the greatest factor contributing to their success, but then the technology involved becomes a common-sense knowledge within the company. The next goal for the company will be to apply the common-sense knowledge to the development of another product and make money. I firmly believe that the technology that has become common-sense knowledge should be entered in textbooks. Although it is a term I have coined, please allow me to call it "postcompetitive." All of you may say that what is most important is the precompetitive part. For me, this is not the case, and the most important part is postcompetitive. After a competition has ended, recording what was born of the competition and leaving the records as a legacy to the next generation is what I call the systematization of manufacturing technology. Since Japan has developed so many highly profitable manufacturing technologies, many textbooks should have been published, and these textbooks, written in English of course, should have found an outlet in countries in the South, as well as in other countries. For example, great expectations of the Institute of Precision Engineers have been expressed by foreign countries. In a survey conducted by IEEE entitled, "What Japanese journals are you most interested in?", the BULLETIN OF THE INSTITUTE OF PRECISION ENGINEERS won second place. This was probably due to the foreigners' expectations—expectations that what has been supporting the postcompetitive manufacturing technology of Japan may be described as a systematic science in a way comprehensible to others. The reality is that since most of the bulletin is written in Japanese, foreigners cannot read it. This increases their frustration. The type of knowledge that we Japanese consider common-sense knowledge is floating in midair in Japan, but the reality is that this very same common-sense knowledge is shielded from the foreigners' eyes. We Japanese have been thoroughly negligent in our effort to record postcompetitive technology in textbooks. I am not saying that we have been sitting on the effort intentionally, but might it not have been because we have never gone through the experience as such?

Take optical disks, for example. RCA spent large sums of money to research and develop around three technological methods, but failed. However, RCA published the research results in an article. This is what I learned from a researcher in optical disks, but according to the story, Japanese enterprises all devoured the paper as if it were the Bible. They successfully commercialized the technology, and the products are being widely accepted. The people who conducted the basic research failed to raise profits, but they left the research achievements as a legacy to the next generation. Nobody ordered the researchers to do so, but they might have published their research out of consciousness of their social responsibilities or due to their desire to record their achievements. Their motive has no relevance here at all. What matters

is that competitive technology is destined to become postcompetitive technology which, in due time, will be open to the public and will become part of the public knowledge. Postcompetitive knowledge is taught at school as basic technology. Since success in having reaped profits in industry must always have been made possible by the development of a new technology, the technology will have to be input into the basic technology taught at school when it has matured to postcompetitive technology. The students who have learned the basic technology will again challenge a precompetitive technology. This cycle needs to be established. We have not been contributing to this cycle. This is another cause of irritation to the Europeans and Americans. The problem will not go away until we have got on with the work of formulating manufacturing technology as a systematic science.

6. The Need for International Collaborative Research

For the Japanese, the technology with which they are familiar is stored in their bodies and brains as common-sense knowledge. They do not think of it as technology. For foreigners, it turns out to be superb technology. One example is that in Japan, the lead time from design and development to the final product is very short. This is due to the fact that people from the manufacturing division participate from the design stage, offering their opinions, and hence mutual understanding exists. The manufacturing division also takes part in the planning stage and discusses the details. Regarded as common sense in Japan, we have thought of this act as related to human behavior or the norm rather than as a technological system. But from the American's viewpoint, it is special. They often say that a tall wall stands between the design and manufacturing divisions. I am told that the traditional American method is: the designer designs the final plan and gives it to the manufacturing division, and then the manufacturing division toils over the design plan. Conversely, there is no wall in the case of Japan, and the work progresses through the cooperation of both sides. This is termed concurrent ideology. It is reported that an American has said of Japan, "There is concurrent engineering in the country," and this seems to be symbolic. Since the practice is common sense for the Japanese, we have heard little of the concept concurrent engineering. We thought it was like saying, "Let's hold a meeting," and no more than that. However, Americans took note of the fact that some new technological concept not seen in existing technology exists in concurrent engineering. Concurrent engineering is in fashion now, and many Japanese have been approached and asked in interviews, "What are you doing?" The experience makes these Japanese realize, "We are concurrent [engineers]." Whether the design and manufacturing divisions have been provided in advance with the kinds of information they need—this is what distinguishes us from the American version of design technology. From the initial stages of design work, terms that are comprehensible to the engineers are used. This is, in reality, a new technology. I have come to maintain the hypothesis

that unless we commit ourselves to international collaborative research, keeping in mind what I have said above, textbooks on manufacturing technology may never see the light of day. Systematization is well advanced in physics and other sciences, so even if no international cooperative research is ever undertaken, academic papers can be prepared according to the established rules. However, in manufacturing engineering, a linguistic system has yet to be established, so it is difficult for the Japanese to convey their ideas correctly to foreigners. This demands that efforts be made, through international collaborative research, to develop a common language. Physics, for example, has a long history, and out of joint research efforts undertaken by people speaking different languages, a linguistic system specific to physics, that is neither English nor German, has been born. Through this medium, ideas have diffused among peoples. Ours is short in terms of history. Therefore, as long as countries of the world continue to conduct development activities, isolating them from other countries in the name of competition, we will hardly be able to resolve the previously-described positive feedback, i.e., the concentration of knowledge in selected countries. Hence, we come to the conclusion that the most important thing is to raise the diffusivity of knowledge by developing a common language.

From the foregoing line of thinking, two things emerge from IMS. One is a futuristic type of new system, and the other is the basic system of manufacturing engineering. The basic system of manufacturing engineering, similarly to Newton's mechanics, will be comprehensible to everyone. Every one of us, be it the Japanese, Americans or Indians, can understand Newton's mechanics. What about manufacturing engineering, then? The only route available to us now is to take the plant and everything else over to a foreign country. What I am proposing is to establish the basic theory, something like Newton's mechanics, underlying manufacturing engineering. In Japan and the United Kingdom, Newton's mechanics can be explained by the falling of an apple, but in the countries in the southern hemisphere the apple is replaced by a banana because apples do not grow in those countries. The two phenomena are different, but the Newton's mechanics underlying them are the same. Therefore, if basic manufacturing engineering is established as a science, the science will never be called CIM in China, but will be referred to as HIM. Because China has a huge population, it will try to exploit the abilities of its human resources to the highest degree in order to manufacture the same automobiles or quality products. We should develop textbooks showing the road to HIM. This is termed "social optimization," and what constitutes an optimal plant will differ from one social environment to another. Where there is a large population, there will be no need for an unmanned plant, whereas in countries suffering from labor shortages, automation should be introduced. As things stand now, automated plants and human-wave plants are treated as belonging to quite different technological systems, and hence an idea conceived in one of them cannot be transferred to

the other, hindering the efforts toward standardization. If something like Newton's mechanics were to exist that would allow for the falling of either a banana or an apple, the Chinese could read it and build an optimal plant best suited to their social environment. I am wondering if establishing something like a common foundation, as described above, might not be the job for researchers belonging to the Institute of Precision Engineers. I call it the systematization of manufacturing engineering. As I said previously, the job will have to be undertaken as an international collaborative project.

7. IMS International Collaborative Research Program

To be concrete, last year I floated a proposal for an IMS international collaborative research program, causing a great uproar. As I have already described, basic manufacturing technology is widely thought to represent a competitive edge, that is, a cutting edge for manufacturing. If we failed to keep the cutting edge secret, our company would go under, and hence the idea for common possession is out of the question—this was the first response to my proposal for joint research. However, as the discussion progressed, my idea was taken up as a project by the Ministry of International Trade and Industry [MITI]. During the initial phases of the project, invitations to foreign countries were sent under my name, not MITI's, and the responses of these countries were the same: How can research on manufacturing technology, the key to competition, be conducted jointly? Is it not that Japan is again trying to steal knowledge from abroad? Desperate efforts at persuasion through various connections have convinced the United States and Europe to come to the conclusion that it is important for the healthy growth of the manufacturing technology of the future; the way it is now, this growth will be limited. Why the process unfolded the way it has is a long story, so I am not going to dwell on it now, but plan to tell it on some other occasion. Anyway, given the economic and social structure, all have some feeling of anxiety about the future of manufacturing technology. The United States and Europe have come to recognize that joint research, like that on IMS, may provide a breakthrough to the impasse, and the work is taking the form of a tripolar international collaborative research project. Regional representatives from MITI, the United States Department of Commerce [DOC], and the DG 13 (13th Bureau) of the EC held their first meeting in May. The first meeting apparently ended in a quarrel, but during subsequent discussions, a consensus was obtained to hold a second tripolar meeting in Japan on 19 and 20 September. Regarding the questions at issue, the first concerns the problem of the spheres of technology to be covered under the collaborative research setup, while the second pertains to the forms of cooperation. The second issue is very important, and opinions are divided between concentrated research and dispersed research. Europe insists on a dispersed or decentralized type of research. Since people from different countries will be able to spend days and nights together, I am advocating a proposal to set up a research center,

but I believe the problem can be fully discussed even after the research has commenced. This is called a problem of modality. The third involves intelligent property rights. The fourth is related to the funding mechanism, such as where should the money come from? Who should pay for a specific kind of research—the government or the private enterprises participating in the project? Pending a basic consensus on these four points, the project is scheduled to go into gear.

Regarding intelligent property rights, I said previously that there was the opinion that "for a company to make its intelligent property rights public would be disadvantageous to its interests." This could be the case, of course. What I am proposing is that by gearing consideration of the intelligent property rights heavily to their positive aspects, their release to the public may be made possible. Currently, the reality is that the only recourse to obtaining a return on manufacturing technology is to market products based on the technology and thus raise profits. However brilliant a manufacturing technology you may have discovered, all you can do is manufacture products to make money. An idea for a product is patentable, but manufacturing technology currently cannot be patented. If manufacturing technology becomes marketable as a patent, its patent may be marketed rather than the products. However, this increases the complexity because of the economic considerations involved. Simply stated, suppose a company has invented a manufacturing technology and the firm decides to market 7,000 units of the product instead of the purported 10,000 units and make up the difference between the realized income and probable income by marketing the knowledge it has obtained. The existing liberalized economy has been liberalized for products, but it is a closed economy as far as knowledge is concerned. To put it in an extreme form, the new liberalized economy I am proposing comes down to this: Manufacture the goods domestically, but market the knowledge on the international market—a concept termed "product nationalism and knowledge globalism." "Product nationalism and knowledge globalism" has now come to be accepted as a system. The underlying idea is that "on the condition that knowledge be allowed to be kept secret, one may market his products anywhere, and no walls should be erected." I am of the opinion that the system—a system in which marketing products is the

only way to raise profits—has gone too far. To be extreme, knowledge should become the leading player in trade and manufacturing should be undertaken in plants that are most suited socially to do the job, with the best of the best products from these plants being provided to nearby consumers. Why is it that automobiles designed by people who have never been to Africa sell well in Africa? There is something wrong with this. Cars for Africans should be built by the Africans themselves. This is an extreme case and is not yet feasible, of course. Nonetheless, I cannot help but wonder if the foregoing might not be ideal; there will be a market for manufacturing technology, for one, and development competition will be waged the world over. I hope the proposal for IMS will be understood in the context of economic and social images, as described above. However, the issue is too large, and hence it will have to await verification from economic considerations. The objective is: Do not force corporations into the position of losing money but, at the same time, make sure that those areas left behind with the diffusion will prosper.

For this reason, I expect that large numbers of people from all walks of life, including sociologists, economists, managers and people engaged in the development of new technology, will indicate their interest in this project. As for engineers who will take part in this project, I expect them to show interest not only in its technological issues, but also in its economic aspects. Since the project's second objective—establishing manufacturing engineering as a science—demands experimentation in the fusion of diverse disciplines that have, until now, been considered alien, including not only technology, in the narrow definition of the term, but also economy, commerce and culture, I sincerely request that people from all walks of life participate actively in the project.

Note: This paper has been edited based on an interview with Yoshikawa. The responsibility for this article rests with Hiromichi Fukuchi and Yukinori Ariga.

References

"Promotion of the IMS International Joint Research Program," JOURNAL OF THE JAPAN SOCIETY FOR THE PROMOTION OF MACHINE INDUSTRY, Japan Society for the Promotion of Machine Industry, 23 Sep 1990.

Atomic Energy Commission's Report on Fuel Recycling, Plutonium LWR

92FE0044A Tokyo GENSHIRYOKU SANGYO
SHIMBUN in Japanese 8 Aug 91 pp 1,4

[Text] On 2 August the Japan Atomic Energy Commission (JAEC) approved the draft of a concrete policy on fuel recycling which is premised on estimated use of plutonium in Japan in 2010. It was compiled earlier by the Commission's expert group on nuclear fuel recycling (chaired by Hiroshi Murata, director of the Japan Atomic Energy Relations Organization). With this, Japan has entered a new stage toward full-scale use of plutonium. The report stresses the need and significance of recycling, citing the fact that fuel recycling will contribute to preservation of resources and will reduce environmental impact. Additionally, with regard to the plutonium supply and demand outlook for 2010, the report said that supply will be about 85 tons and demand, focusing on pluthermal use in light water reactors (LWRs), will be about 50 tons.

With regard to the need and significance of fuel recycling, the report reconfirms that nuclear energy is an economical and stable source of energy in the long term and is superior in terms of energy security, and it stresses that recycling makes the control of radioactive waste more suitable.

In order to ensure nuclear non-proliferation when using plutonium, the report says that it is important to give consideration to transparency of recycling plans so that they do not arouse international concerns about the issue of nuclear non-proliferation and, at the same time, to give strict observance to nuclear non-proliferation. It declares that it is important to work actively to improve safeguards technology in order to maintain and strengthen the safeguards system of the International Atomic Energy Agency (IAEA) and to contribute to sound development of the IAEA safeguards system and the strengthening of the world's nuclear non-proliferation system.

As for the fundamental thinking behind future recycling plans, the report maintains that it is important to make systematic and solid progress in radioactive waste control and that scale and methodology of recycling will be flexible. Furthermore, the report once again stresses the standing position that the main user of plutonium will be fast breeder reactors (FBRs), which will be the main reactors in the nuclear power plants of the future, but it states that for the present, efforts will be made to use plutonium in LWRs.

Under the outlook for plutonium use, the assured amount (estimate of cumulative amount) for 2010 is given as about 5 tons from the Tokai reprocessing plant, 50 tons from the Rokkasho reprocessing plant and 30 tons commissioned from foreign countries, for a total of about 85 tons. The used amount is given as 12 - 13 tons used by the FBRs "Joyo" and "Monju," 10 - 20 tons by FBR demonstration reactors and others, and less than 10

tons by a new type of advanced conversion reactor (ATR). On the other hand, the outlook also maintains that use of plutonium in LWRs will be increased in planned stages: By the mid-1990's, one-fourth the core of one pressurized water reactor (PWR) and one boiling water reactor (BWR) in the 800,000 kilowatt (KW) or more class will be plutonium-uranium mixed oxide (MOX) fuel; by the end of the 1990's, one-third of the core of about four LWRs in the 1 million KW class will be MOX fuel; and after 2000, the number of these LWRs will increase to about 12.

The report states that the Power Reactor and Nuclear Fuel Development Corporation (PNC) will create domestic MOX fuel fabrication systems for use by FBRs and ATRs, but the private sector should immediately begin studies toward realizing the use of PNC technology for FBR demonstration reactors. The report maintains that the promotion of domestic commercial fabrication of MOX fuel for LWRs must be promoted in response to the commencement of operation of the Rokkasho reprocessing plant and that a commercialization policy should be drawn up as soon as possible.

As for plutonium recovered through reprocessing overseas, the report states that it is appropriate to fabricate a certain amount of MOX fuel overseas for a certain period of time. With regard to sea transport, the report states that it is necessary for the electric power companies to study concrete measures to ensure smooth transport.

The report states that re-enrichment through recycling is the best way to use recovered uranium, and it calls upon the private sector and PNC to cooperate in development.

Excerpt from JAEC Fuel Recycling Report

As stated in the article on page 1, the JAEC has drawn up a scheme for the use of plutonium up to the year 2010. In the scheme, it is stated that when Japan actively uses plutonium, which is a militarily sensitive substance, "it is important that the plan be transparent both domestically and internationally," and it reveals the overall scheme. In this article, we will look at the latter half of the report, which follows the section on "necessity and significance of nuclear fuel recycling" and "addressing nuclear non-proliferation" and is more detailed.

(In this article, plutonium volume (estimated) means fissionable plutonium volume.)

Use of Plutonium

A. Plan for Use in FBRs and ATRs

With regard to FBRs, it is appropriate to continue R&D in the demonstration reactor "Joyo" and promote the use of recycling by the prototype reactor "Monju," in view of the important roles played by these reactors in FBR development. These two reactors will need about .6 tons of plutonium per year, or a cumulative amount of 12 - 13 tons by around 2010.

Plans are underway on the FBR demonstration reactor with a view toward beginning construction in the latter half of the 1990's and starting operation after 2000. It is important to promote this plan actively and also systematically and effectively promote reactors that will succeed the demonstration reactor, with a view toward commercialization of FBRs. The amount of plutonium needed by the demonstration reactor and succeeding FBRs will have to be assessed accurately as the plans for each reactor become more concrete, but at this time, it is estimated that the cumulative amount needed by around 2010 will be 10 - 20 tons. The range of fluctuation will depend mainly on when FBRs are introduced and their scale.

Thus demand by 2010 will be greatly influenced by the plans, not only for the demonstration reactor but also for succeeding reactors, and continuous study of these plans from a long-range viewpoint is desirable.

With regard to ATRs, operation of the prototype reactor "Fugen" is continuing with the goal of further improvement of reliability, etc., and work is proceeding on plans for the construction of a demonstration reactor in Oarai, Aomori Prefecture, with the goal of beginning operation around 2000. Steady promotion of these projects is important from the viewpoint of increasing the flexibility of nuclear fuel recycling systems. The amount of plutonium that will be needed by the "Fugen" and the demonstration reactor currently being planned is .5 - .6 tons per year, and the cumulative amount that will be needed from this fiscal year to around 2010 is under 10 tons.

B. Plans for Use by LWRs

Based on the results of the current small-scale demonstration project, it is judged that in the initial part of a future nuclear fuel recycling project using LWRs, it is appropriate to adopt a recycling method wherein one-fourth of the core of one BWR and one PWR in the 800,000 KW class or higher is MOX fuel by the mid-1990's. It is appropriate that the electric power companies make the necessary preparations for smooth implementation of this plan.

The purpose of the use of nuclear fuel recycling by LWRs is to play some role in the area of energy supply and, looking to the commercial use of FBRs in the future, to prepare technologies and systems that will be needed for nuclear fuel recycling on a commercial scale. To realize these goals, it is essential that LWR use of nuclear fuel recycling be continuous on a scale that is appropriate to the scale of commercial reprocessing facilities and commercial MOX fuel fabrication facilities. In the case of Japan, it is appropriate that preparations be made to steadily increase usage in stages so that by the end of the 1990's, one-third of the cores of four LWRs in the 1 million KW class will be loaded with MOX fuel and that after 2000, the number of these LWRs will be increased to 12.

The amount of plutonium needed to implement this plan for use by LWRs is estimated to be a cumulative amount of 50 tons by around 2010. It is important that the specific tempo of expansion of the scale of usage be steady and flexible, based on how fast FBRs and ATRs commence using fuel recycling.

Also, government and the private sector must work together on this plan, and it is appropriate that the relevant ministries and agencies provide the necessary support.

Ensuring Plutonium

It is estimated that 80-90 tons of plutonium will be needed by around 2010 for use in the recycling plans for FBRs, ATRs, and LWRs.

However, the amount of plutonium that will be supplied from various sources—the Tokai reprocessing plant, the Rokkasho reprocessing plant, and overseas reprocessing facilities in Britain and France—will depend on the type and volume of spent fuel that will be reprocessed and thus can only be estimated. At this point in time, the soundest estimate of the volume of supply is as follows:

Tokai reprocessing plant: It is believed that for the present, the annual amount reprocessed will be 70 - 90 tons (amount of spent fuel converted to uranium), and about .4 tons plutonium will be recovered each year. However, when the Rokkasho reprocessing plant begins operation, the primary function of the Tokai reprocessing plant is expected to shift to development of technologies concerning MOX fuel reprocessing, etc., and the amount of plutonium recovered at this plant is expected to drop to .1 - .2 tons per year.

Rokkasho reprocessing plant: This plant is expected to begin operation at the end of the 1990's. Reprocessing will be increased in stages so that operation at the capacity level of 800 tons per year (amount of spent fuel converted to uranium) can begin after 2000. The scale of this plant is the same as the UP3 plant in France, and is appropriate for a commercial reprocessing facility. At full-scale operation, the plant is expected to recover about 4.5 - 5 tons of plutonium each year.

Overseas reprocessing: Based on the contracts concluded by Japanese electric power companies with British and French reprocessing companies, the cumulative amount of recovered plutonium is estimated to be 30 tons. It is believed that all of this plutonium will have been brought back to Japan by around 2010.

Using the above as the basis of calculations, the total supply by around 2010 will be about 85 tons—5 tons from the Tokai plant, 50 tons from the Rokkasho plant and 30 tons from overseas facilities. Total demand, taking into consideration such factors as the need for some running stock in a real supply and demand program, is expected to be 80 - 90 tons. Therefore, it is judged that this supply amount of 85 tons is the amount that will be needed to realize the recycling plan.

Domestic MOX Fabrication

MOX Fuel Fabrication System for FBRs, ATRs

PNC will continue to fabricate MOX fuel for the FBR demonstration reactor "Joyo" and prototype reactor "Monju" and the ATR prototype reactor "Fugen;" and in accordance with existing policy, PNC's third plutonium fuel development laboratory will build a fuel fabrication facility to provide MOX fuel for the ATR demonstration reactor.

Considering the fact that concrete progress is being made on the FBR demonstration reactor project, a detailed study must be conducted immediately on the application of PNC's technology for fabricating MOX fuel for FBRs.

MOX Fuel Fabrication System for LWRs

In response to the commercialization of reprocessing at the Rokkasho plant, commercialization of MOX fuel fabrication for LWRs must be promoted in Japan. The following policy is stated in the long-term plan for development and use of nuclear energy: "In principle, MOX fuel for the full-scale use of plutonium by LWRs will be provided by private industry. A concrete fuel fabrication system will be established in the early 1990's at the latest." In view of the plan for LWR use of fuel recycling and the expectation that the Rokkasho reprocessing plant will begin operation at the end of the 1990's, efforts must be made to establish domestic commercial MOX fuel fabrication capability of about 100 tons per year by around 2000, and it is appropriate that a detailed study of the content of work be conducted, led by the relevant parties in the private sector. However, it is important that this domestic MOX fuel fabrication enterprise be able to respond flexibly in accordance with the tempo of expansion of the scale of recycling by LWRs. Considering the lead time needed to determine who will lead the enterprise, select the site and design the facility and the time needed for safety inspections, construction and test operation, the stage has been reached where a commercialization policy should be drawn up as soon as possible.

Incidentally, to promote commercialization of domestic MOX fuel fabrication, domestic technology for fabrication of MOX fuel for LWRs must be demonstrated and PNC's MOX fuel fabrication technology must be transferred to private industry. Towards this end, PNC and the relevant private companies must proceed with a study immediately on such matters as the use of PNC's third plutonium fuel development laboratory.

Overseas MOX Fabrication

As for plutonium recovered through overseas reprocessing, overseas fabrication of a certain amount of MOX fuel for a certain period of time is appropriate.

Therefore, the electric power companies should study immediately the date for commencement of overseas MOX fuel fabrication and the scale of the processes to be commissioned.

The MOX fuel manufactured overseas will be transported by sea to Japan. The electric power companies must study specific transporting methods so that transporting can be carried out smoothly in strict conformance with not only Japanese law but also with international agreements, such as the relevant stipulations in the U.S.-Japan nuclear energy agreement, the nuclear substances protection treaty and IAEA transport regulations. Incidentally, with regard to the transport plan, it is necessary that the LWR recycling plan that will begin in the mid-1990's be implemented without delay, and the government is requested to provide the necessary measures and support through close cooperation among the relevant ministries and agencies.

Incidentally, in the event that MOX fuel is fabricated in a country with which Japan has not concluded a nuclear cooperation agreement, it will entail the transfer of Japan's plutonium to a third country, and new measures will have to be created to guarantee peaceful use.

Use of Recovered Uranium

From the viewpoint of further advancing the philosophy of recycling of resources, it is important that active efforts be made to use uranium recovered through reprocessing. In terms of economy and usable amount, the most appropriate method of recycling is thought to be re-enrichment. Therefore, to prepare for full-scale use in the future, it is appropriate that the relevant private parties and PNC cooperate in developing a system on a realistic scale that covers conversion, re-enrichment, fabrication and reactor use, based on past achievements.

Furthermore, considering efficiency of transport and other factors, it is appropriate that the uranium recovered through reprocessing that has been commissioned overseas be converted and re-enriched before return to Japan, and it is desired that the electric power companies make the necessary preparations. Incidentally, if this conversion or re-enrichment is to be carried out in a country with which Japan has not concluded a nuclear cooperation agreement, new measures to guarantee peaceful use will have to be created.

MOX Reprocessing

From the viewpoint of recycling of resources, it is also important to recover plutonium and uranium by reprocessing the spent MOX fuel that is created during fuel recycling. Toward this end, it is appropriate that PNC proceed with development of technologies that will raise the efficiency of MOX fuel reprocessing and recovery, including spent fuel from FBRs and ATRs.

NTIS
ATTN PROCESS 103
5285 FORT ROYAL RD
SPRINGFIELD VA

2

22161

This is a U.S. Government publication. Its contents in no way represent the policies, views, or attitudes of the U.S. Government. Users of this publication may cite FBIS or JPRS provided they do so in a manner clearly identifying them as the secondary source.

Foreign Broadcast Information Service (FBIS) and Joint Publications Research Service (JPRS) publications contain political, military, economic, environmental, and sociological news, commentary, and other information, as well as scientific and technical data and reports. All information has been obtained from foreign radio and television broadcasts, news agency transmissions, newspapers, books, and periodicals. Items generally are processed from the first or best available sources. It should not be inferred that they have been disseminated only in the medium, in the language, or to the area indicated. Items from foreign language sources are translated; those from English-language sources are transcribed. Except for excluding certain diacritics, FBIS renders personal and place-names in accordance with the romanization systems approved for U.S. Government publications by the U.S. Board of Geographic Names.

Headlines, editorial reports, and material enclosed in brackets [] are supplied by FBIS/JPRS. Processing indicators such as [Text] or [Excerpts] in the first line of each item indicate how the information was processed from the original. Unfamiliar names rendered phonetically are enclosed in parentheses. Words or names preceded by a question mark and enclosed in parentheses were not clear from the original source but have been supplied as appropriate to the context. Other unattributed parenthetical notes within the body of an item originate with the source. Times within items are as given by the source. Passages in boldface or italics are as published.

SUBSCRIPTION/PROCUREMENT INFORMATION

The FBIS DAILY REPORT contains current news and information and is published Monday through Friday in eight volumes: China, East Europe, Soviet Union, East Asia, Near East & South Asia, Sub-Saharan Africa, Latin America, and West Europe. Supplements to the DAILY REPORTs may also be available periodically and will be distributed to regular DAILY REPORT subscribers. JPRS publications, which include approximately 50 regional, worldwide, and topical reports, generally contain less time-sensitive information and are published periodically.

Current DAILY REPORTs and JPRS publications are listed in *Government Reports Announcements* issued semimonthly by the National Technical Information Service (NTIS), 5285 Port Royal Road, Springfield, Virginia 22161 and the *Monthly Catalog of U.S. Government Publications* issued by the Superintendent of Documents, U.S. Government Printing Office, Washington, D.C. 20402.

The public may subscribe to either hardcover or microfiche versions of the DAILY REPORTs and JPRS publications through NTIS at the above address or by calling (703) 487-4630. Subscription rates will be

provided by NTIS upon request. Subscriptions are available outside the United States from NTIS or appointed foreign dealers. New subscribers should expect a 30-day delay in receipt of the first issue.

U.S. Government offices may obtain subscriptions to the DAILY REPORTs or JPRS publications (hardcover or microfiche) at no charge through their sponsoring organizations. For additional information or assistance, call FBIS, (202) 338-6735, or write to P.O. Box 2604, Washington, D.C. 20013. Department of Defense consumers are required to submit requests through appropriate command validation channels to DIA, RTS-2C, Washington, D.C. 20301. (Telephone: (202) 373-3771, Autovon: 243-3771.)

Back issues or single copies of the DAILY REPORTs and JPRS publications are not available. Both the DAILY REPORTs and the JPRS publications are on file for public reference at the Library of Congress and at many Federal Depository Libraries. Reference copies may also be seen at many public and university libraries throughout the United States.