

# LOAN DOCUMENT

PHOTOGRAPH THIS SHEET

DTIC ACCESSION NUMBER

LEVEL

INVENTORY

DOCUMENT IDENTIFICATION

DISTRIBUTION STATEMENT

ACCESSION BY	
NTIS	GRAM <input checked="" type="checkbox"/>
DTIC	TRAC <input checked="" type="checkbox"/>
UNANNOUNCED	<input type="checkbox"/>
JUSTIFICATION	
BY	
DISTRIBUTION/	
AVAILABILITY CODES	
DISTRIBUTION	AVAILABILITY AND/OR SPECIAL
A-1	

DISTRIBUTION STAMP

DATE ACCESSIONED

DATE RETURNED

19981223 020

DATE RECEIVED IN DTIC

REGISTERED OR CERTIFIED NUMBER

PHOTOGRAPH THIS SHEET AND RETURN TO DTIC-FDAC

H  
A  
N  
D  
L  
E  
  
W  
I  
T  
H  
  
C  
A  
R  
E

UNCLASSIFIED

NADC

NO DISTRIBUTION  
STATEMENT

tech. info!

APPENDIX 34

IFMR - SC INTERFACE

FINAL SOFTWARE REPORT

DATA ITEM NO. A005

# INTEGRATED ELECTRONIC WARFARE SYSTEM ADVANCED DEVELOPMENT MODEL (ADM)

7800987-34

PREPARED FOR:

NAVAL AIR DEVELOPMENT CENTER  
WARMINSTER, PENNSYLVANIA

CONTRACT N62269-75-C-0070



ELECTROMAGNETIC  
SYSTEMS DIVISION

1 OCTOBER 1977

UNCLASSIFIED

APPENDIX 34  
IFM RECEIVER/SYSTEM CONTROLLER INTERFACE

FINAL SOFTWARE REPORT

DATA ITEM A005

INTEGRATED ELECTRONIC WARFARE SYSTEM (IEWS)  
ADVANCED DEVELOPMENT MODEL (ADM)

Contract No. N62269-75-C-0070

Prepared for:

Naval Air Development Center  
Warminster, Pennsylvania

Prepared by:

RAYTHEON COMPANY  
Electromagnetic Systems Division  
6380 Hollister Avenue  
Goleta, California 93017

1 OCTOBER 1977



IFMR/SC INTERFACE  
INTERFACE CONTROL UNIT1.0 SCOPE

This document shall describe the interface between the IFMR and the System Controller. The functional as well as the detailed physical requirements shall be included in this document.

2.0 APPLICABLE DOCUMENTS

IEWS ICD 53959-NK-1400

IEWS ICD 53959-DB-1011

3.0 REQUIREMENTS

An interface shall be established between the IFMR and the System Controller to enable the transfer of CW detection signals. The IFMR/SC interface shall be organized as shown in Figure 1.

3.1 OPERATIONAL REQUIREMENTS

The System Controller shall be required to initiate specific techniques against CW threats. To facilitate this operation, the IFMR must generate CW alerts and associated frequency data to the S.C. whenever a CW signal is detected.

### 3.2 PERFORMANCE REQUIREMENTS

#### 3.2.1 Detection

Every 10 ms the IFMR shall attempt to detect a CW signal. When a CW signal is detected, the IFMR shall produce a CW Detection flag and a two bit CW BAND code every 10 ms for the duration of the CW signal.

#### 3.2.2 Data Transmission

CW detection data shall be transferred from the IFMR to the SC via a serial interface as shown in figure 1. Each transfer shall consist of a serial word with 3 of the 8 data bits being used. Each CW Detection flag initiates a data transfer by loading a CW DETECTION flag and a 2 bit CW BAND  $\emptyset - 1$  code into the serial word, as shown in figure 2.

#### 3.2.3 SC Data Handling

The SC serial interface receives the data from the IFMR and stores it in a double buffer. This data shall be sampled at a rate determined by the SC software. If the rate is less than one sample per 10 ms, the second buffer must be sampled until the buffer is empty in order to obtain the latest CW information.

3.2.4 Software Routine

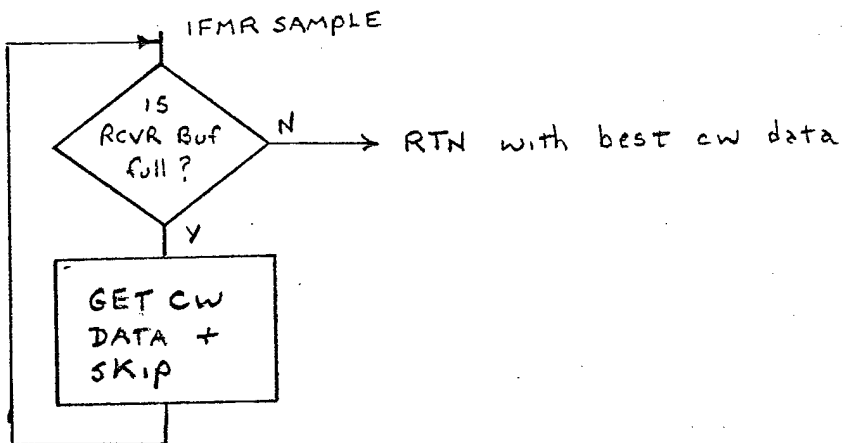

3.3 DATA STRUCTURE

The IFMR/SC interface, as shown in Figure 3, shall consist of:

- 1 CW Detection
- 1 CW Band 00
- 1 CW Band 01

3.4 DESIGN REQUIREMENTS

3.4.1 Line Drivers/Line Receivers

All line drivers and line receivers shall incorporate SN75110 and SN75107A type devices respectively. The IFMR output shall be terminated on both ends with the termination network specified in Figure 4.

3.4.2 Interconnecting Transmission Lines

The IFMR/SC interface shall consist of a RCV line, a XMIT line, a RCV BUFF EMPTY line, and a MASTER CLR line as shown in figure 3. Only the RCV line shall be connected in the IFMR. All interconnection cables used for this interface shall utilize twisted pair. The characteristic impedance shall be  $110\Omega \pm 5\%$ . A termination plug shall be provided which is a matched pair ( $\pm 1\%$ ) of 56 ohm resistors for each signal and its return as shown in figure 4.

3.4.3 Interface Signal Definition

Figure 3 provides the interface signals between the IFM and the System Controller. Signals CW Band 00+ and CW Band 00- are the signal and the return respectively.

CW DETECTION - A logic signal generated by the IFMR upon detection of a CW signal.

CW BAND (00-01) - A two bit word generated by the IFMR which indicates which band has detected the CW signal. Only one CW signal may be detected.

MSB	LSB	
0	0	8-10 GHz
0	1	10-12 GHz
1	0	12-14 GHz
1	1	14-16 GHz

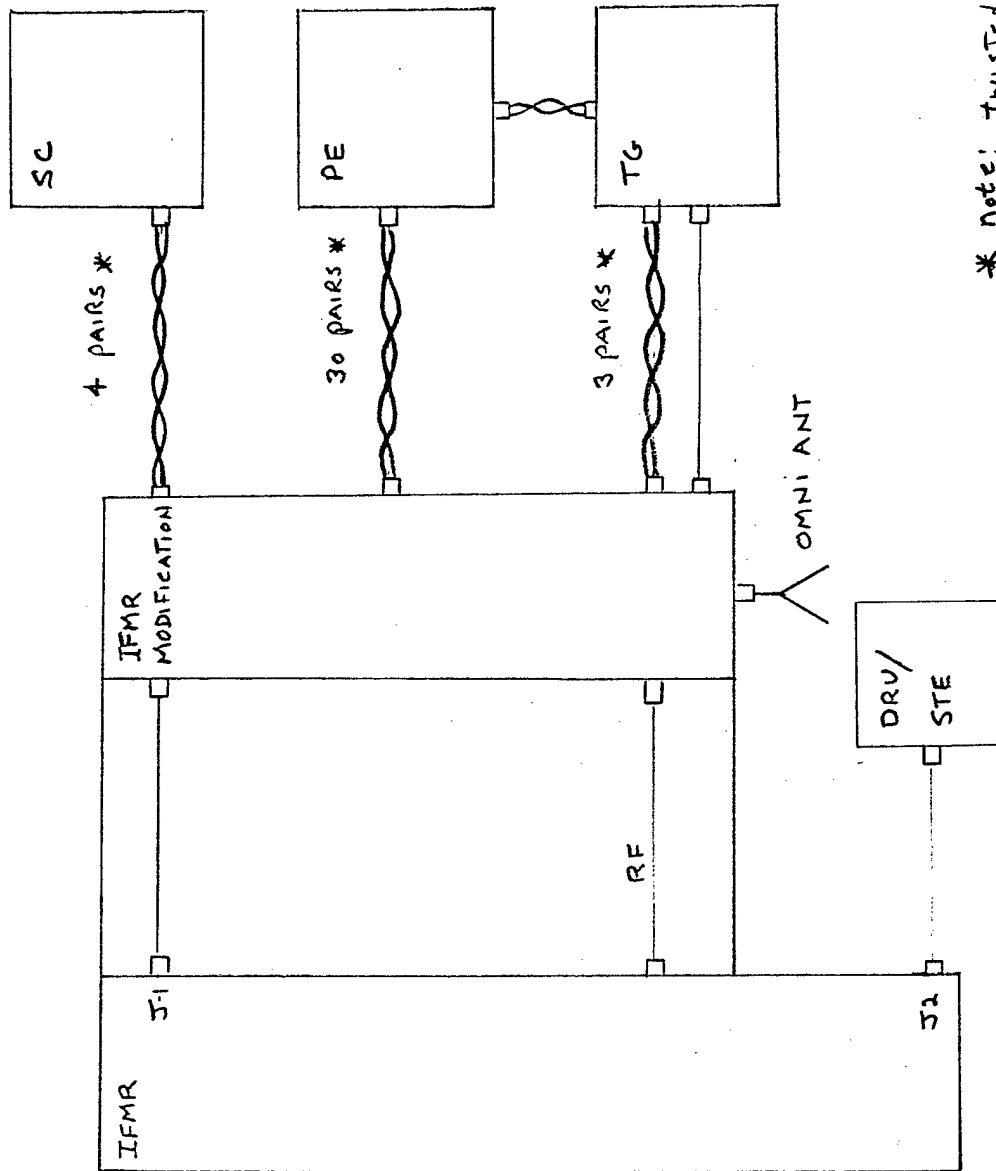

\* Note: Twisted #24 AWG  
 $Z_0 = 110 \Omega \pm 10\%$

FIG 1 IFMR/SC INTERFACE

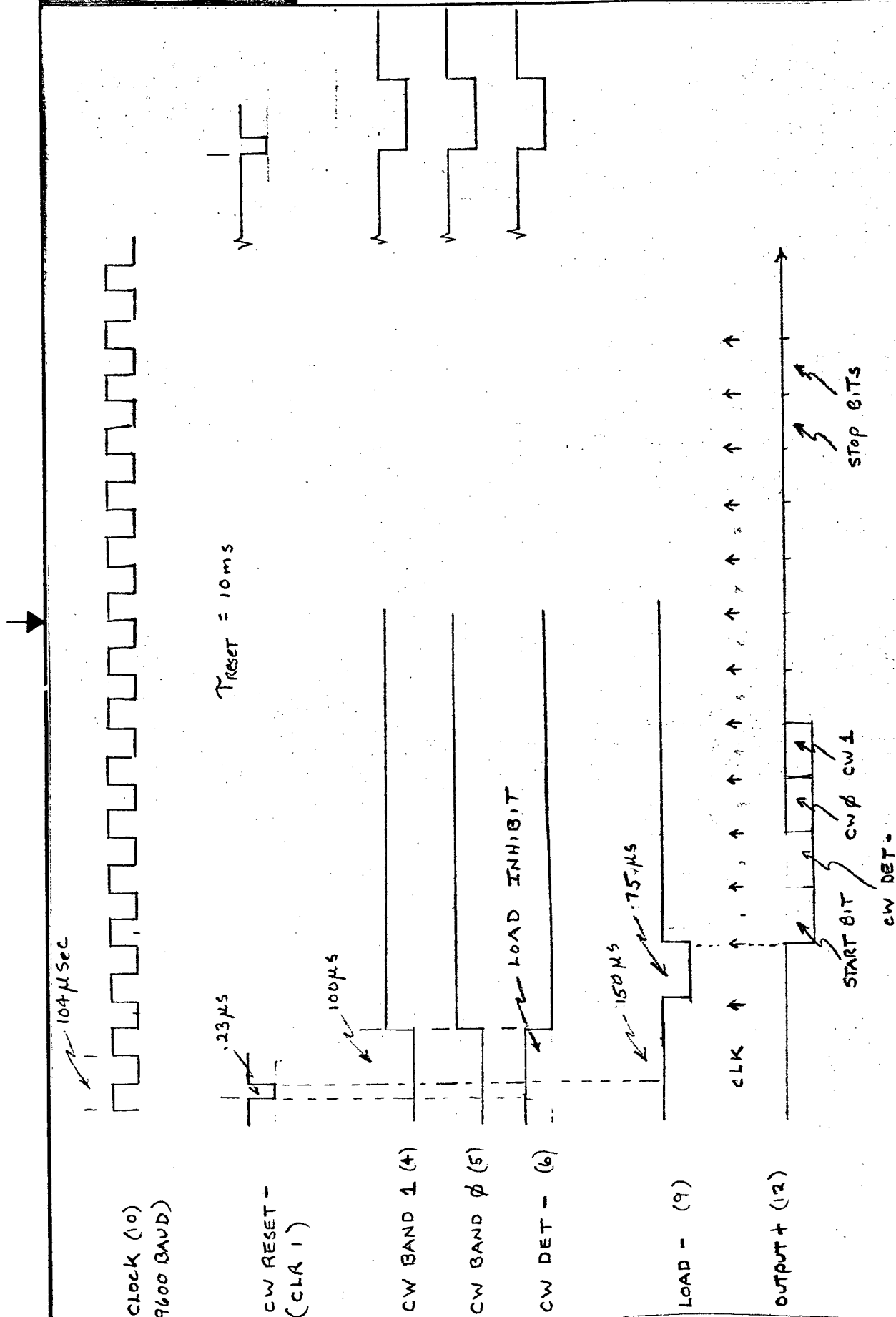

IFMR TIMING fig. 2

**RAYTHEON**

RAYTHEON COMPANY  
LEXINGTON, MASS. 02173

CODE IDENT NO.

49956

SPEC NO.

SHEET  
8 OF

REV

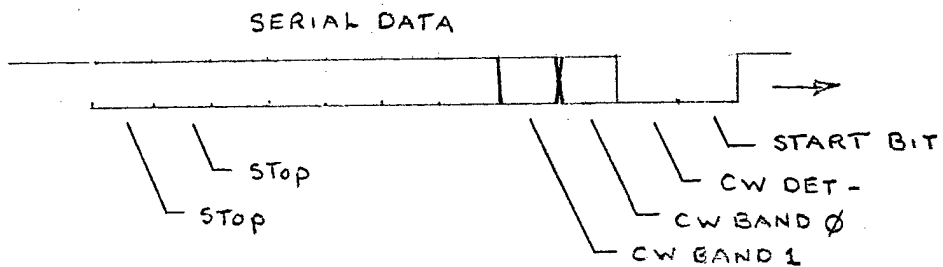
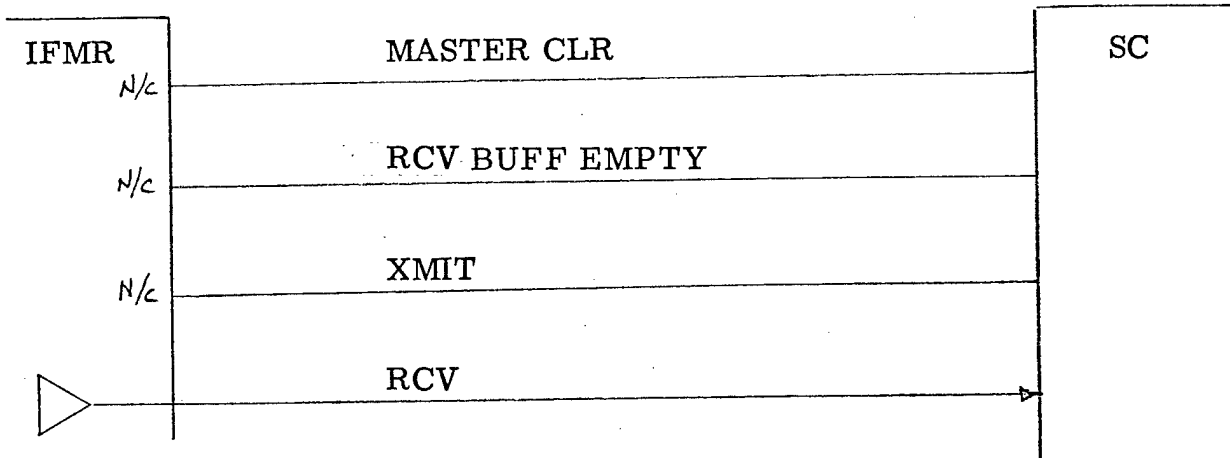

IFMR/SC INTERFACE

Figure 3

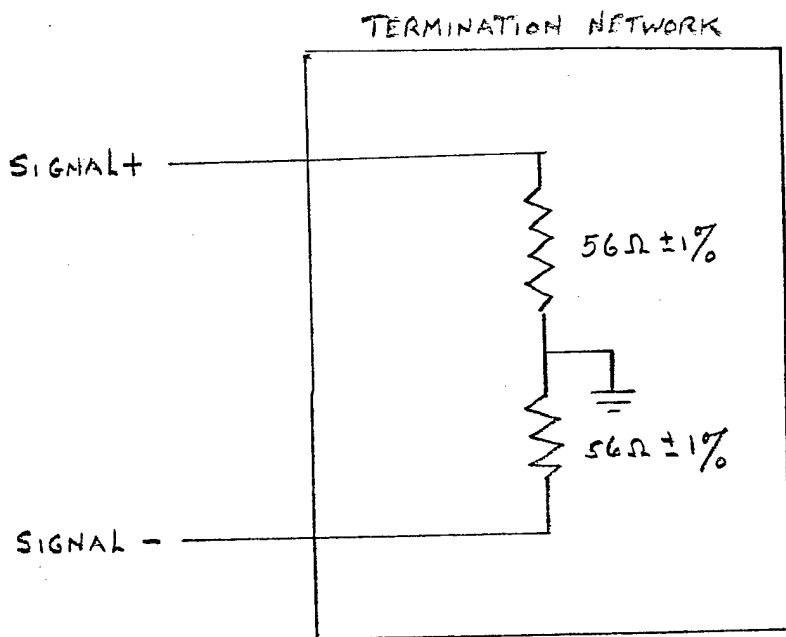

FIGURE 4 IFMR TERMINATION