

The contents of this report are not to be used for advertising, publication, or promotional purposes. Citation of trade names does not constitute an official endorsement or approval of the use of such commercial products.

The findings of this report are not to be construed as an official Department of the Army position, unless so designated by other authorized documents.



PRINTED ON RECYCLED PAPER

Technical Report EL-98-17
December 1998

Evaluation of Infrasound and Strobe Lights for Redistributing Migrant Salmon Smolts in the McNary Juvenile Bypass: 1997

by Peter N. Johnson

ASCI Corporation
1365 Beverly Road
McLean, VA 22101

Gene R. Ploskey

U.S. Army Corps of Engineers
Waterways Experiment Station
3909 Halls Ferry Road
Vicksburg, MS 39180-6199

Final report

Approved for public release; distribution is unlimited

Prepared for U.S. Army Engineer District, Walla Walla
Walla Walla, WA 99362-1876



**US Army Corps
of Engineers**
Waterways Experiment
Station

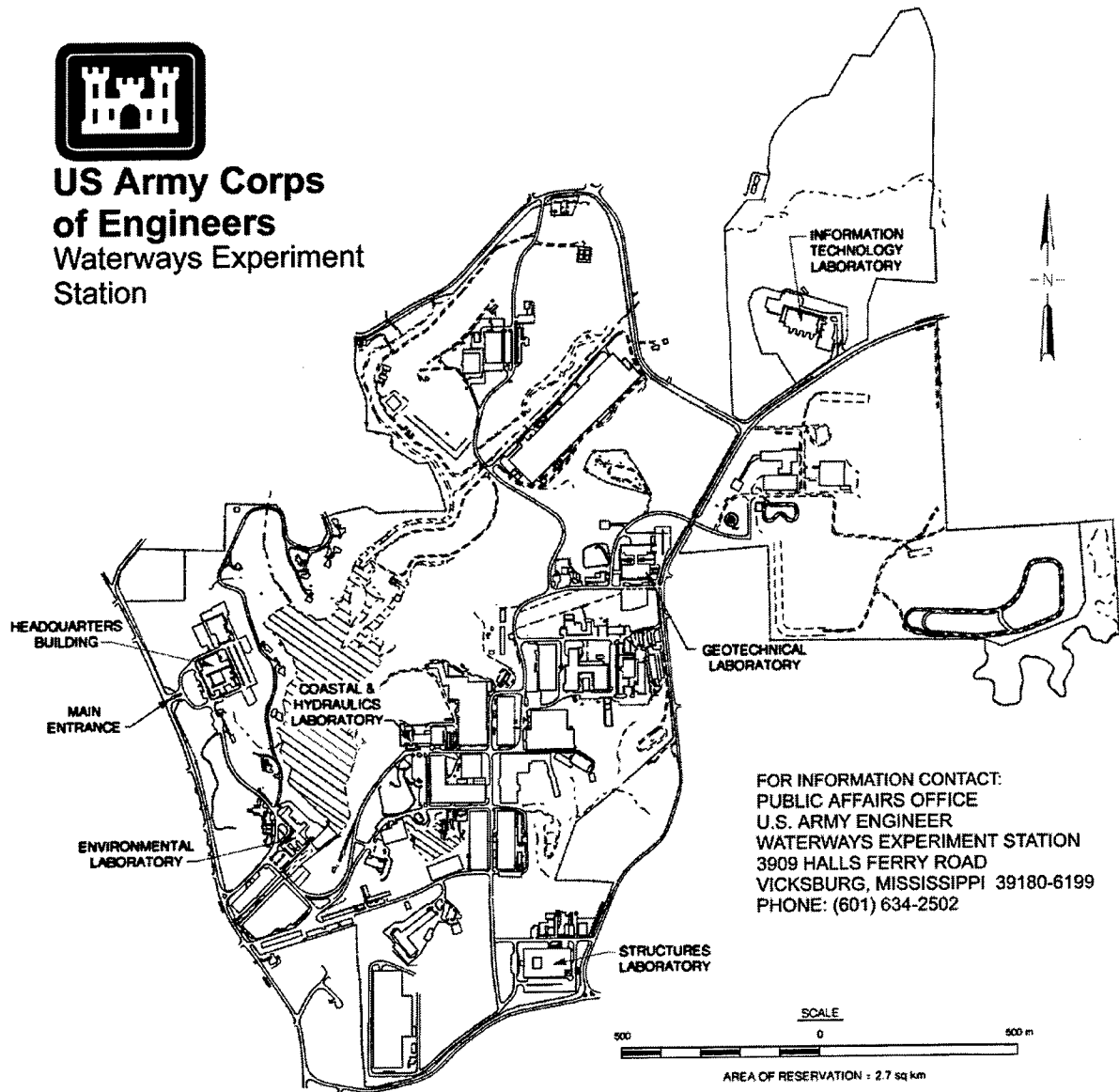

Waterways Experiment Station Cataloging-in-Publication Data

Johnson, Peter N.

Evaluation of infrasound and strobe lights for redistributing migrant salmon smolts in the McNary juvenile bypass, 1997 / by Peter N. Johnson, Gene R. Ploskey ; prepared for U.S. Army Engineer District, Walla Walla.

30 p. : ill. ; 28 cm. — (Technical report ; EL-98-17)

Includes bibliographic references.

1. Infrasound waves — Evaluation. 2. Salmon. 3. Smolting. 4. McNary Reservoir (Wash. and Or.) 5. Fishes — Migration. I. Ploskey, Gene R. II. United States. Army. Corps of Engineers. Walla Walla District. III. U.S. Army Engineer Waterways Experiment Station. IV. Environmental Laboratory (U.S. Army Engineer Waterways Experiment Station) V. Title. VI. Series: Technical report (U.S. Army Engineer Waterways Experiment Station) ; EL-98-17.

TA7 W34 no.EL-98-17

Contents

| | |
|---|----|
| Preface | v |
| Conversion Factors, Non-SI to SI Units of Measurement | vi |
| 1—Introduction | 1 |
| 2—Materials and Methods | 3 |
| McNary Project Site Description | 3 |
| Strobe Lights..... | 4 |
| Infrasound..... | 7 |
| Infrasound Surveys | 9 |
| Video Processing and Subsampling..... | 9 |
| 3—Results | 11 |
| In-channel Distribution..... | 11 |
| Strobe Lights..... | 11 |
| Infrasound..... | 12 |
| Infrasound Surveys | 14 |
| Propagation of Infrasound through Screens..... | 14 |
| Holding Behavior..... | 16 |
| 4—Discussion..... | 17 |
| 5—Conclusions and Recommendations | 19 |
| References | 20 |
| SF 298 | |

List of Figures

| | | |
|-----------|--|----|
| Figure 1. | Map of Columbia River Basin showing location of McNary Dam..... | 3 |
| Figure 2. | Underwater camera locations within the McNary juvenile bypass..... | 5 |
| Figure 3. | Cross-sectional view of center camera and light assembly showing position of strobe light for April 1997 testing in the McNary juvenile bypass channel | 6 |
| Figure 4. | Front view of strobe light locations for April 1997 testing in the McNary juvenile bypass channel | 6 |
| Figure 5. | Plan and cross-sectional views of Alden Research Laboratory's particle motion generator for April 1997 testing in the McNary juvenile bypass channel..... | 8 |
| Figure 6. | Three-dimensional view of Argotec's reciprocating piston-driven infrasound device | 9 |
| Figure 7. | Mean and maximum sound pressure levels recorded from a stationary smolt transport barge below McNary Dam at 0.6-m depth | 15 |
| Figure 8. | Mean and maximum sound pressure levels recorded from McNary fish separator..... | 15 |
| Figure 9. | Plan view of a section of the McNary juvenile bypass channel showing radio-telemetry antennae locations | 16 |

Preface

The report herein was prepared by the Fisheries Engineering Team, Water Quality and Contaminant Modeling Branch (WQCMB), Environmental Processes and Effects Division (EPED), Environmental Laboratory (EL), U.S. Army Engineer Waterways Experiment Station (WES), with support from the ASCl Corporation (ASCl), McLean, VA. This work was funded by U.S. Army Engineer District, Walla Walla (CENWW).

The report was prepared by Messrs. Peter N. Johnson (ASCl) and Gene R. Ploskey, (WQCMB) and was conducted under the general supervision of Dr. Mark S. Dortch, Chief, WQCMB, Dr. Richard Price, Chief, EPED, and Dr. John Harrison, Director, EL. Mr. Mike Burczynski, Dyntel, Inc.; Mr. David Leese, Instrumentation Systems Development Division, Information Technology Laboratory, WES; and Ms. Gina George, Ms. Athena Stillinger, and Mr. Jason King, student contractors, helped deploy gear and collect and process video data. Ms. Nicole Ricci, ASCl, provided additional video processing support. Mr. Rip Shively, Ms. Theresa Martinelli, Ms. Jill Hardiman, Mr. Bob Wertheimer, Mr. Brad Liedtke, and Ms. Rachel Wardell of the U.S. Geological Survey, Biological Resources Division, Columbia River Research Laboratory, graciously provided expertise and assistance with the holding behavior element of this study.

Local support was provided by Mr. Brad Eby, Senior Biologist, McNary Dam, U.S. Army Engineer District, Walla Walla, and his team of biotechnicians. Crane support was provided by Lynn McComas, National Marine Fisheries Service (NMFS), and McNary Project personnel.

At the time of publication of this report, Director of WES was Dr. Robert W. Whalin. Commander was COL Robin R. Cababa, EN.

This report should be cited as follows:

Johnson, P. N., and Ploskey, G. R. (1998). "Evaluation of infrasound and strobe lights for redistributing migrant salmon smolts in the McNary juvenile bypass: 1997," Technical Report EL-98-17, U.S. Army Engineer Waterways Experiment Station, Vicksburg, MS.

The contents of this report are not to be used for advertising, publication, or promotional purposes. Citation of trade names does not constitute an official endorsement of approval for the use of such commercial products

Conversion Factors, Non-SI to SI Units of Measurement

Non-SI units of measurement used in this report can be converted to SI units as follows:

| Multiply | By | To Obtain |
|----------------------|------------|--------------|
| cubic feet | 0.02831685 | cubic meters |
| feet | 0.3048 | meters |
| miles (U.S. statute) | 1.609347 | kilometers |

1 Introduction

Implementation of surface collector technology at Columbia River dams will require handling of substantially more water in juvenile bypass systems (JBS) or other channels. Concentration of fish guided by existing turbine screens and future surface collectors will require increased dewatering, either by increased screening or more efficient dewatering. The use of infrasound or lights to redistribute smolts away from screens in bypass channels might allow for increased dewatering without jeopardizing safe passage, if the devices prove to be highly effective. Even if moderately effective, these technologies still may prove to be useful for reducing smolt holding and thereby improve passage efficiency for areas where changes in the channel or flow cause delays.

Carlson (1994) conducted an extensive review of the use of sound to protect fish at hydropower facilities, and Nestler et al. (1994) developed the original rationale for the Acoustic Technologies Program funded in Fiscal Year (FY) 1995. These references provide a good historical overview of the state of the art of technologies at that time.

The most consistently successful guidance or deterrence of fish with sound at electric generating facilities has been achieved using high-frequency sound (> 100 KHz) on anadromous fishes of the genus *Alosa*, including American shad (Ploskey, Pickens, and Weeks 1994), blueback herring (Nestler et al. 1992; Ploskey et al. 1995), and alewives (Dunning et al. 1992; Ross et al. 1993).

Researchers have demonstrated that the water-particle-motion component of infrasound (sounds < 20 Hz) is an effective stimulus for eliciting avoidance responses in Atlantic salmon smolts (Knudsen, Enger, and Sand 1992; Taft et al. 1995) and chinook salmon and steelhead smolts (Knudsen and Schreck, in preparation). Infrasound testing in tanks in FY 95 with yearling smolts > 150 mm (Knudsen and Schreck, in preparation) provided conclusive evidence of vigorous avoidance of infrasound. The particle-motion component predominates near the sound source (within about 3 m) and may exhibit directivity, and the amplitude of the signal diminishes in proportion to the inverse of the cube of range. The other component of infrasound is pressure, which predominates away from the sound source, diminishes at about $20 \times \log(\text{range})$, is heard by most fishes, but has not been shown to elicit avoidance. The directivity and limited range of effectiveness of infrasound are valuable assets for guiding fish without deterring passage through intakes or channels.

Fish most vulnerable to injury in dewatering facilities, e.g., juvenile salmonids < 70 mm long, also exhibit strong avoidance responses to infrasound (Mueller et al. 1998). Groups of rainbow trout and hatchery and wild chinook salmon ranging from 45 to 65 mm long were successively acclimated to a net pen in a large 7.3- by 3.7-m oblong tank and exposed to 10-Hz sounds 5 sec in duration in July 1996. Down-looking and two side-looking cameras were used to record vertical, lateral, and longitudinal movements of the juveniles as they responded to infrasound. All size groups of fish exhibited innate avoidance of infrasound to the extent permitted by the enclosure.

Light is an effective stimulus to which juvenile salmonids and other fishes respond. However, the nature of the response (avoidance or attraction) may not be consistent and may depend upon the specimen's state of acclimation to ambient lighting and the intensity of the test light (e.g., Puckett and Anderson 1987; Nemeth and Anderson 1992). This hypothesis may explain the many apparently inconsistent responses obtained in tests with constant light.

Craddock (1956) reviewed some early unpublished research on guiding downstream-migrating salmon to light in the Northwest. Testing by the U.S. Fish and Wildlife Service at the Bonneville Fisheries Engineering Research Laboratory conclusively proved the preference of salmon for lighted orifices. Today smolts are attracted through orifices in gatewell slots of many Columbia River dams by constant light. This use was derived in part from early work by Fields et al. (1958).

A substantial volume of literature documents fish avoidance of strobe lights, as described in a review by Winchell, Amaral, and Taft (1994). Avoidance by hatchery-reared subyearling chinook salmon and steelhead was observed in a flume under static conditions (Puckett and Anderson 1987; Nemeth 1989; Anderson, Puckett, and Nemeth 1988). However, strobe lights appeared to be ineffective at improving fish guidance efficiency at Rocky Reach Dam (Anderson, Puckett, and Nemeth 1988), although sounds generated by the travelling screen may have adversely affected smolt guidance and the potential effectiveness of the lights. By contrast, McKinley and Patrick (1988) found 56 percent effectiveness in diverting downstream migrating sockeye salmon away from turbine intakes at Seton Hydroelectric Station in British Columbia.

The second year (FY 97) of behavioral technology evaluation in the McNary JBS focussed on the following objectives:

- a. Evaluate the effectiveness of strobe lights and infrasound for redistributing migrant smolts from the side dewatering section of the McNary bypass channel.
- b. Survey and describe areas within fish transport barges and the McNary wet separator for ambient sources of infrasound.
- c. Evaluate the potential for propagating infrasound through screening material.
- d. Test for holding behavior by releasing radio-tagged smolts during on/off behavioral device treatments.

2 Materials and Methods

McNary Project Site Description

McNary Dam is located on the Columbia River at River Mile 292 in south-central Washington State (Figure 1) and serves as a multipurpose Corps of Engineers (CE) project. McNary consists of two small house units to provide internal power requirements, a 14-turbine powerhouse (three intakes per turbine unit), a 22-gate spillway structure, and a navigation lock. There are extensive facilities to aid in the collection and transportation of both juvenile and adult migrating salmonids.

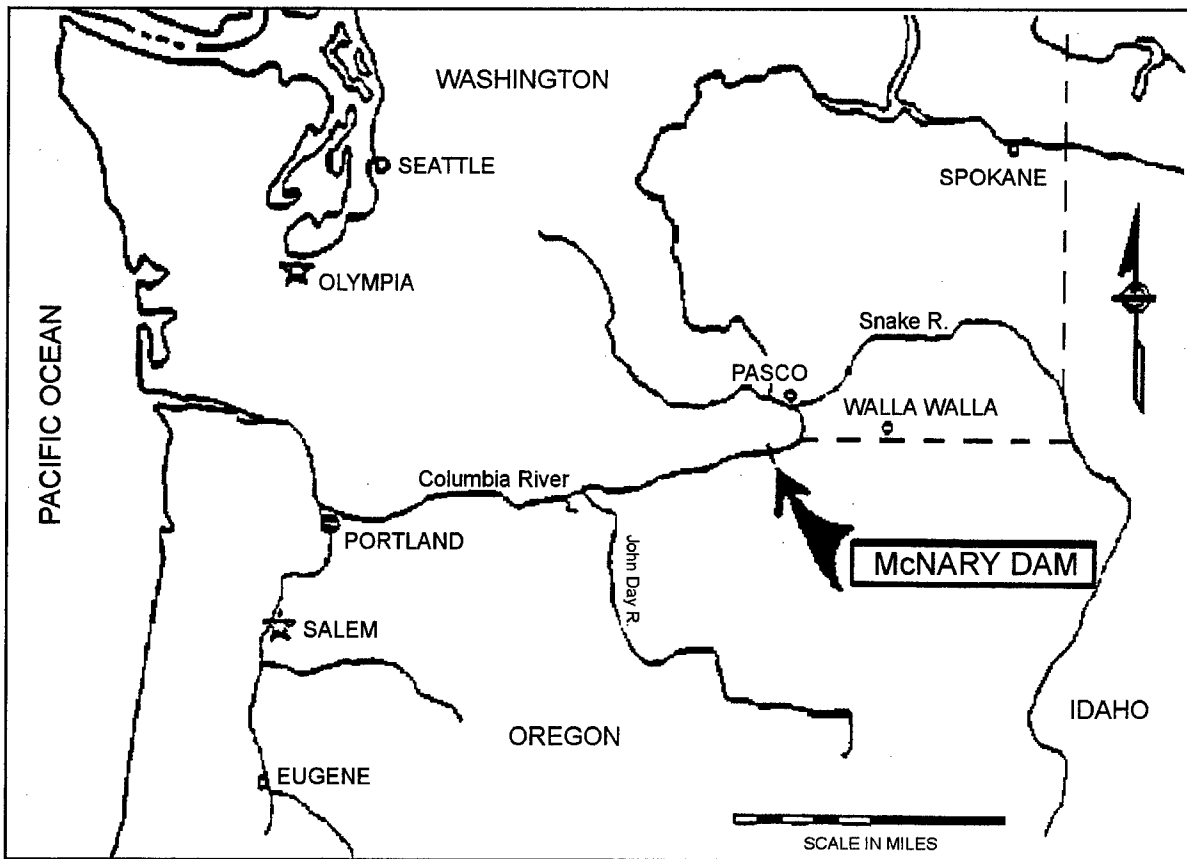

Figure 1. Map of Columbia River Basin showing location of McNary Dam (to convert miles to kilometers, multiply by 1.6)

Strobe Lights

Springtime strobe light tests were initially conducted 14-19 April 1997. A total of 19 test hours and 19 control hours of video data were acquired with test treatments switched every hour for up to 8 hr per evening. Tests began at 1715 hr on the first night and 1800 hr on all other nights. We reversed the treatment schedule on successive days so the same hours on successive days received different treatments. We tested the use of strobe lights again 12-15 May 1997. A total of 18 test hours and 18 control hours of video data were acquired. Evaluations started at 1700 hr and continued for 12 hr each evening. Treatments were randomly assigned at the beginning of each 4-hr block. Turbidity was measured nightly using a Lamotte nephelometer.

Monitoring gear consisted of three high-resolution black and white infrared-sensitive underwater cameras spanning the width of the channel just upstream of the side dewatering platform (Figure 2). The cameras were suspended from vertical poles, placed 0.3 m below the elevation of the top of the dewatering screens, and aimed down. A single infrared light bank per camera was used to provide illumination. The cameras were spaced laterally as follows: camera 1 was adjacent to the dewatering screen (screen was visible in that camera's field of view for monitoring debris loading); camera 2 was 0.7 m from camera 1; and camera 3 was 0.8 m from camera 2 and nearest to the east wall of the channel.

Testing configuration consisted of a single Flash Technology, Inc., AGL Series 901 strobe head mounted to the middle camera pole 0.5 m above the camera and angled approximately 45 deg toward the screen wall and 20 deg down (Figure 3). We used a flash rate of 100 flashes per minute (fpm) at low intensity (400 watts). AGL Series strobe heads measure 23.5 cm in diameter with a body depth of 17.1 cm.

The monitoring configuration in May differed from that of April with the addition of an overhead camera hung from the crane hook and aimed down to capture avoidance behavior of surface-oriented smolts. The May testing configuration differed from that of April in that instead of using a single strobe head near the monitoring cameras, we used two strobe heads suspended from aluminum poles located along the screened wall at distances of 7.3 and 4.3 m from the monitoring cameras. The heads were placed at the elevation of the center of the top side screens, aimed approximately 20 deg off the screens and with the flow (Figure 4). We used a flash rate of 200 fpm at low intensity.

Summertime strobe light evaluations were conducted in two series: 16-19 July and 22-24 July 1997. In the initial series, strobe light tests commenced at 1800 or 1900 hr and ran until 0600 or 0700 hr the following morning. On and off treatments were either 30 or 60 min in duration, and treatments were randomly assigned at the beginning of every 2-hr block. For the latter series, strobe light tests ran from 1800 hr to midnight. Treatment duration was 15 min, and treatments were randomly assigned every hour.

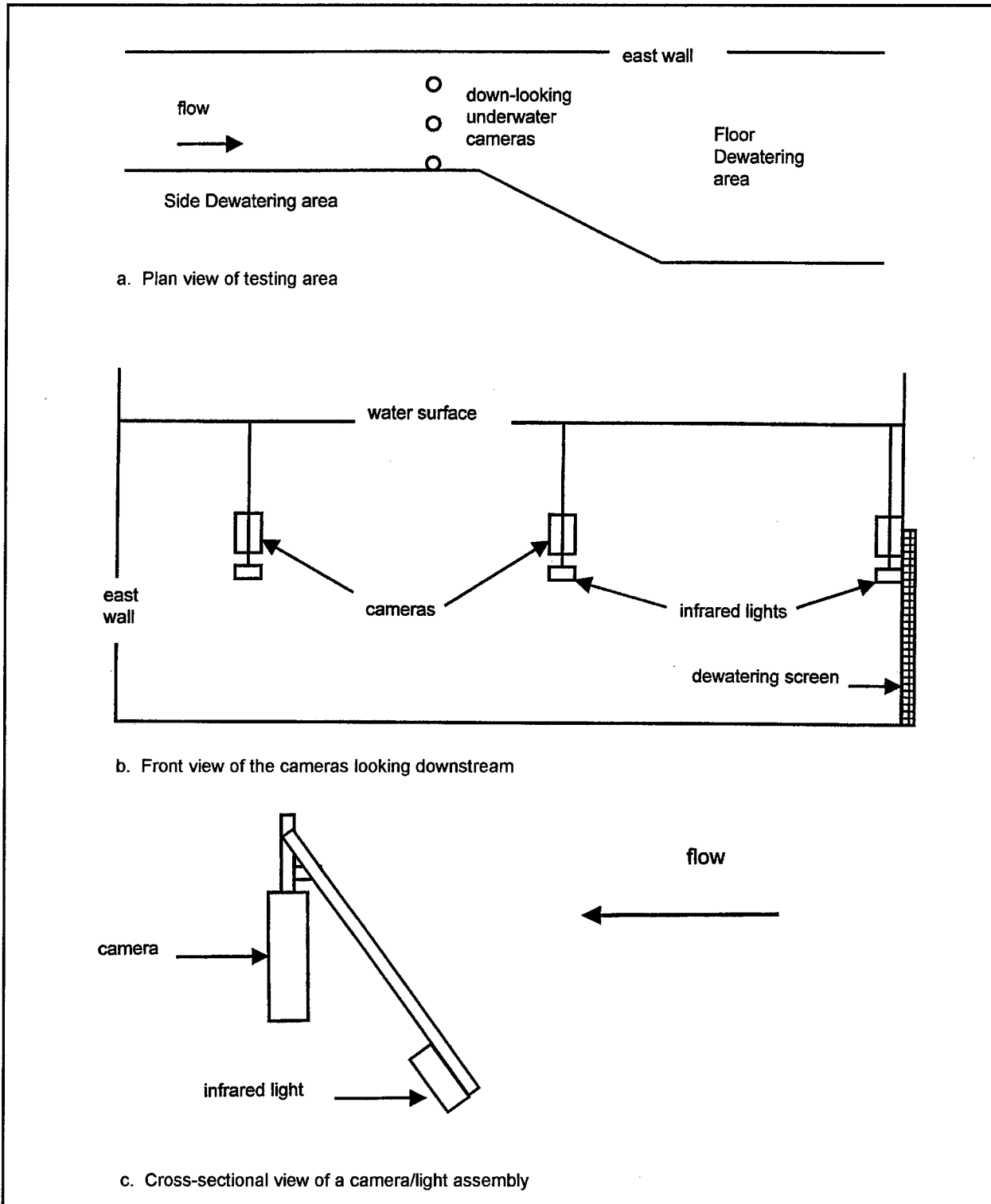

Figure 2. Underwater camera locations within the McNary juvenile bypass (not to scale)

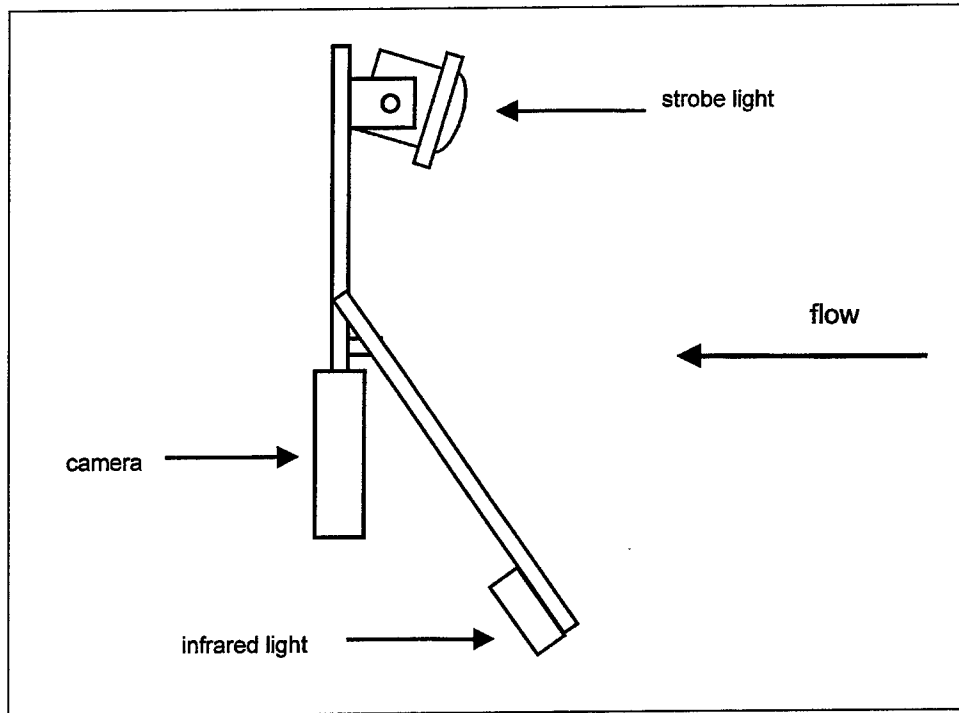

Figure 3. Cross-sectional view of center camera and light assembly showing position of strobe light for April 1997 testing in the McNary juvenile bypass channel. Strobe light orientation of 45 deg toward the screened wall is not shown. Drawing is not to scale

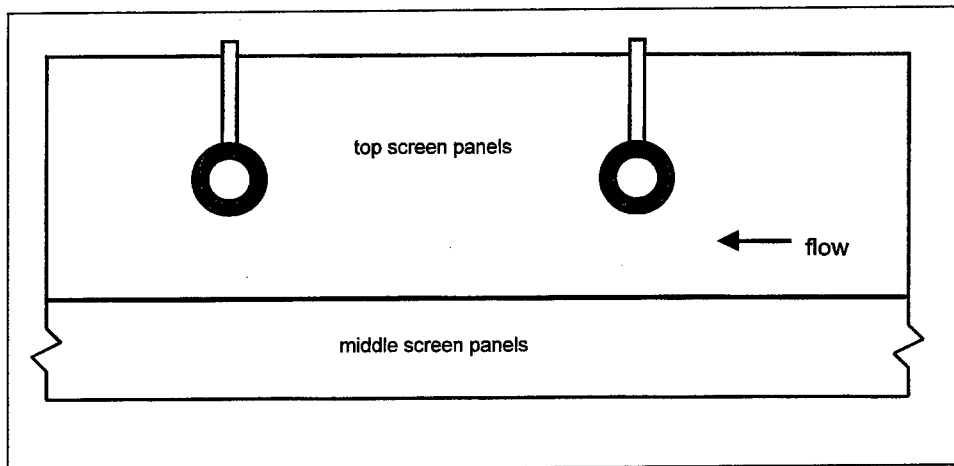

Figure 4. Front view of strobe light locations for April 1997 testing in the McNary juvenile bypass channel. Strobe lights were placed along the face of screens at a distance of 4.3 and 7.3 m upchannel from monitoring cameras. Drawing is not to scale

Strobe light testing configuration for the summer consisted of two strobe heads mounted to the west wall of the chamber behind the side dewatering screens. Strobe heads were placed 7.3 and 11 m, respectively, from the downstream edge of the dewatering panels at an elevation of 1.8 m above the channel floor. Strobe heads were oriented such that the axis of illumination bisected the channel flow. We used a flash rate of 400 fpm at low intensity (400 watts).

Monitoring of summertime strobe light evaluations comprised two modes of data collection: down-looking underwater video cameras and visual observation of smolt behavior near the water surface. Two down-looking video cameras were placed along the dewatering screen wall at distances of 2.1 and 4.3 m, respectively, downchannel from the furthest downstream strobe light. Cameras were dropped to the elevation of the strobe heads. As in the spring, underwater cameras sampled continuously through all on and off treatments. Portions of the dewatering screen were visible in the field of view of both cameras. Observation of near-surface smolt behavior consisted of observers perched on the screen cleaning trough between the two strobe-illuminated areas in the channel during portions of all test treatments when daylight did not preclude visual sampling. Observers recorded the orientation of smolts in terms of head- or tail-first aspect and swimming direction of surface-oriented smolts as they encountered the strobed light stimulus. Directional swimming behaviors recorded included the approximate angle at which smolts changed their swim path (no change, 45 deg, and 90 deg) and direction of change (away from, toward strobe lights).

Infrasound

Springtime infrasound tests were conducted 19-24 April. A total of 20 test hours and 20 control hours of video data were acquired. Test treatments were switched every hour for 8 hr from 1800 to 0200 hr. The first treatment type (test or control) was randomly selected each evening.

Monitoring design for springtime infrasound testing was the same as in April strobe light tests. Deployment of the particle motion generator (PMG) consisted of suspending it from the overhead crane and stabilizing it with a pole and sleeve anchoring configuration (Figure 5). The center of the PMG was located 0.6 m from the screen wall, 2 m from the camera monitoring frame, and at the elevation of the middle of the top side screens.

Summertime infrasound evaluations were conducted 19-21 July 1997. Treatments were 15 min long and randomly assigned at the beginning of each hour. Testing began at 1800 hr and continued until midnight. A total of 36 test and 36 control periods of video data were acquired.

The device tested in the summer was a 1.2-m-long, 0.8-m-high, 1.1-m-wide reciprocating piston-driven PMG manufactured by Argotec, Inc. (Figure 6). We used an overhead crane to suspend the infrasound device and several ropes to stabilize it laterally. The device was placed 5 m upchannel from the furthest downstream monitoring camera, offset toward the screened wall until the crane cable contacted the screen cleaning trough, and lowered 1.2 m below the water

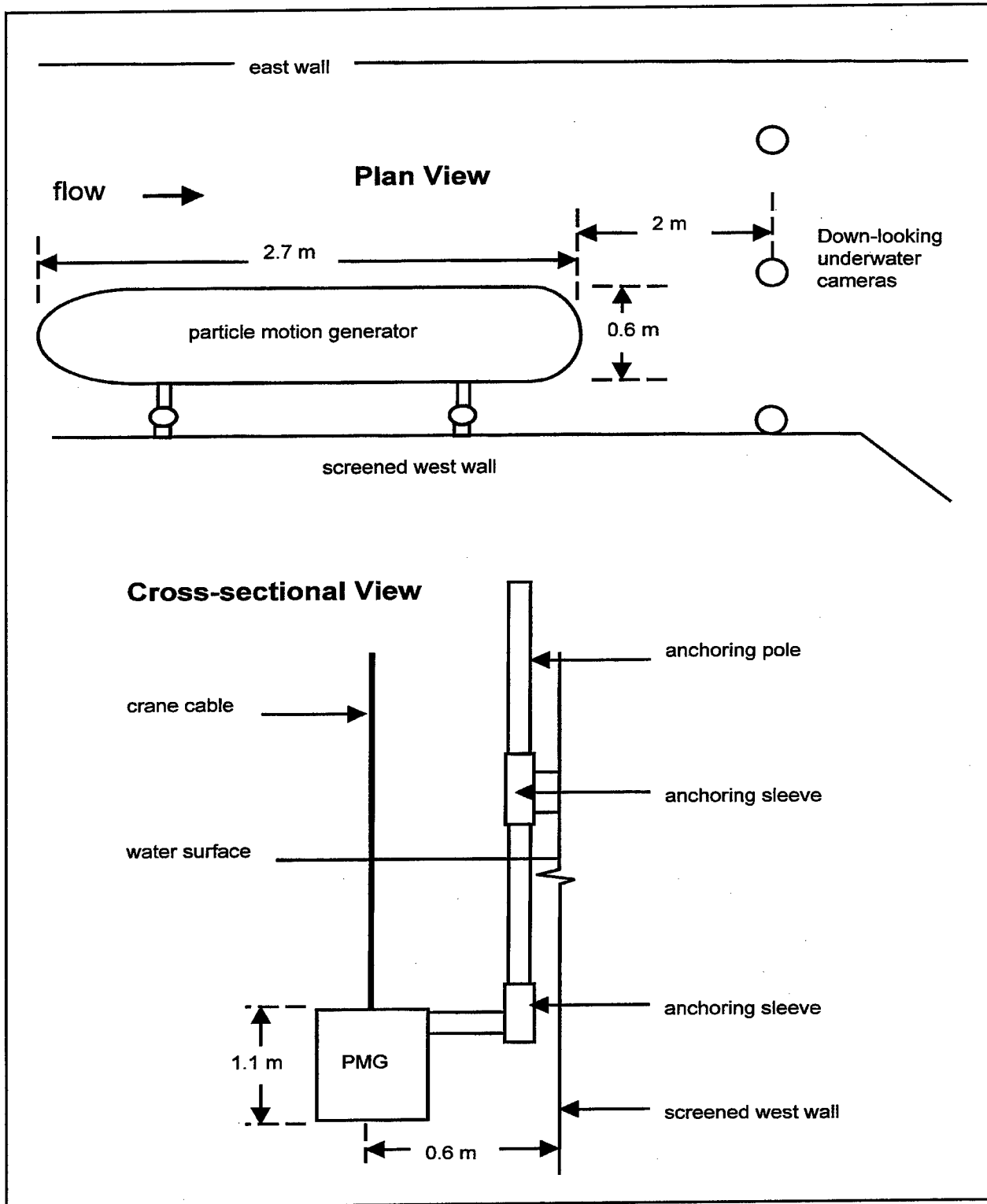

Figure 5. Plan and cross-sectional views of Alden Research Laboratory's particle motion generator (PMG) for April 1997 testing in the McNary juvenile bypass channel. Drawing is not to scale

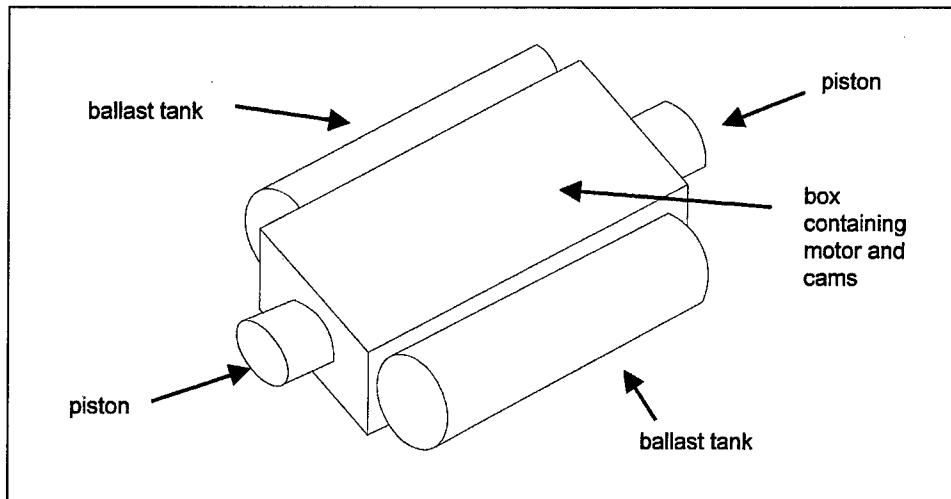

Figure 6. Three-dimensional view of Argotec's reciprocating piston-driven infrasound device

surface to the elevation of the top of the screens. Monitoring camera configuration was the same as for summer strobe light tests except the cameras were raised to the elevation of the infrasound device. All sound tests were run at about 10 Hz.

Infrasound Surveys

Surveys for the presence of infrasound were conducted 12 July in both a fish transport barge parked below the McNary Project and within the McNary JBS wet separator using a multiple sensor fish surrogate (MSFS). The MSFS was used to characterize the frequency and pressure components of underwater sound fields within these environments (for a detailed description of MSFS, see Johnson et al., in preparation). Each of three rectangular bays along the south side of the fish barge was surveyed by deploying the MSFS at each end of the bays at depths of 0.6 and 1.5 m. The MSFS was deployed at nine locations within the wet separator: the top, middle, and bottom of the inlet, center, and outlet of the rectangular device.

Video Processing and Subsampling

To evaluate the effects of stimuli on the distribution of smolts near the dewatering screens, we processed the entire hour for the specific camera nearest the screen and closest to the behavioral device during the hours of 1800 through midnight. To assess in-channel fish distribution and the effects of stimuli on cross-channel distributions, we initially subsampled a portion of each hour from all cameras as representative samples of the data sets. For strobe light evaluations, the April tests were subsampled by randomly choosing three 5-min blocks per hour for all cameras, whereas the May tests were subsampled by randomly choosing two 5-min blocks per hour for all cameras. The infrasound data were

subsampling initially with one 5-min block per 15 min of each hour, and later with one 5-min block per 20 min of each hour for all cameras.

3 Results

In-channel Distribution

Proportional lateral distribution of smolts based upon passage events collected with underwater cameras during springtime control periods is shown in Table 1. Additionally, Table 1 presents mean number of passage events per hour by camera location during control periods. Mean number per hour during control periods was significantly higher near the east wall ($n = 56$; $P > F 0.0005$) than at the other locations.

| Camera Location | Percent Total | Mean No. per Hour | n |
|-----------------|---------------|-------------------|----|
| Near screen | 18.92 | 3.49 | 56 |
| Midchannel | 21.48 | 4.04 | 56 |
| Near far wall | 59.60 | 11.20 | 56 |

Strobe Lights

Strobe light test results in the form of mean numbers per hour of smolt passage events arrayed by camera location are shown in Table 2. Mean numbers of smolt observed per hour were low during both control and test periods for near-screen and midchannel test locations. Due to these low counts, we were unable to conduct analyses of variance and subsequently detect significant differences. The most encouraging results of the strobe light tests are based on observations of the effect of strobe lights on surface-oriented smolts. Deployment of strobe lights along the screened wall in May and behind the screening in July resulted in a backlighting effect that allowed us to observe smolt swimming behavior near the water surface. Near-surface smolts contrasted with the white strobe flashes and appeared as dark silhouettes against the light background. This made possible observations on smolt passage during strobe light-on treatments. Table 3 lists the means and variances associated with numerous swimming behaviors observed during portions of strobe light-on periods. The most common behavioral observation was the tendency of smolts to orient and swim toward the far wall at an approximate 45-deg angle. Other common observations were swimming angles of 90 deg toward the far wall and 45 deg toward the screened wall.

| Test | Dates | Treatment | Mean Count per Hour by Camera Location | | |
|--------------------------------|-------------------|-----------|--|------------|---------------|
| | | | Near Screen | Midchannel | Near Far Wall |
| Strobe lights (midchannel) | 14-18 April | ON | 2 | 5.11 | 17.11 |
| | | OFF | 2.95 | 7.78 | 17.56 |
| Strobe lights (on screens) | 12-15 May | ON | 6.44 | 2.83 | 8.28 |
| | | OFF | 5.94 | 3.61 | 15.67 |
| Strobe lights (behind screens) | 16-18, 22-24 July | ON | 2.41 | n/a | n/a |
| | | OFF | 2.45 | n/a | n/a |

Note: Smolt counts are expanded to full hour coverage.

We measured the orientation angle of passing smolts captured with underwater video cameras during control periods to estimate control conditions for comparison with strobe light-on visual observations of swimming behaviors. A total of 182 smolt passage events in the spring and 54 in the summer were reviewed to document smolt passage orientation. We found that over 97 percent of all smolts exhibited orientation angles between 75 and 105 deg in both spring and summer, where 90 deg represents orientation parallel to the channel walls. Orientation angles of passing smolts can be viewed as an indication of lateral movement, and the severity of the angles indicates potential extent of lateral movement.

Compared to smolt passage during control treatments (i.e., backing down tail first with minimal lateral change in range), strobe light was shown to modify over 96 percent and 99 percent of all passing migrants in the spring and summer, respectively. A total of 84 visual observations of individual fish were recorded in the spring and 1,327 in the summer. The proportion of smolts exhibiting change in lateral range and/or increased swimming speed downstream was 90 percent in the spring and 80 percent in the summer. Proportion of migrants observed to flee the strobe-lighted fields in the direction away from the screens was 65 percent and 42 percent in the spring and summer, respectively. Turbidity levels averaged 13 nephelometric turbidity units (NTU's) in the spring and 7 NTU's in the summer.

Infrasound

Results of the infrasound evaluations are presented in Table 4. Much like the strobe test results, the number of smolts observed per hour near the screen during infrasound testing was insufficient to conduct analyses of variance among on and off treatments. The equality of the means, however, suggests infrasound did not successfully redistribute smolts from the side dewatering screens.

Table 3
Mean and Variance Associated with Exhibited Smolt Behavior in the Presence of Strobe Light Stimulus in McNary Channel, 1997

| Mean and Variance | Swam Upstream without Change in Lateral Strobe Lights | Swam Away from Strobe Toward East Wall (Approximate 90-deg Angle) | Swam Away from Strobe Toward East Wall (Approximate 45-deg Angle) | Initially Swam Upchannel, then Toward East Wall | Head First w/out Lateral Change in Range | Tail First w/out Lateral Change in Range | Head or Tail 1st w/out Lateral Change in Range | Swam Toward Strobe (Approx. 90-deg Angle) | Swam Toward Strobe (Approx. 45-deg Angle) | Ceased Swimming and Alive (Stunned) | Initially Swam Toward East Wall then Toward Strobe | Apparently Dead (Floating on side or Upside Down) | Date n = number of obs. Periods |
|-------------------|---|---|---|---|--|--|--|---|---|-------------------------------------|--|---|------------------------------------|
| MEAN | 0.00 | 0.00 | 3.20 | 0.00 | 0.80 | 0.00 | 0.00 | 0.00 | 0.00 | 0.27 | 0.00 | 0.00 | 12-13 May n = 5 |
| VAR | 0.00 | 0.00 | 6.76 | 0.00 | 0.53 | 0.00 | 0.00 | 0.00 | 0.00 | 0.36 | 0.00 | 0.00 | n = 5 |
| MEAN | 0.00 | 0.00 | 4.56 | 0.00 | 1.70 | 0.36 | 0.00 | 0.00 | 0.19 | 0.24 | 0.19 | 0.74 | 13-14 May n = 6 |
| VAR | 0.00 | 0.00 | 10.48 | 0.00 | 2.36 | 0.38 | 0.00 | 0.00 | 0.25 | 0.25 | 0.25 | 1.08 | n = 6 |
| MEAN | 0.00 | 0.00 | 3.46 | 0.00 | 0.67 | 0.22 | 0.00 | 0.00 | 0.67 | 0.00 | 0.22 | 0.00 | 14-15 May n = 6 |
| VAR | 0.00 | 0.00 | 6.83 | 0.00 | 2.67 | 0.30 | 0.00 | 0.00 | 0.53 | 0.00 | 0.30 | 0.00 | n = 6 |
| MEAN | 0.00 | 3.53 | 3.80 | 0.00 | 3.87 | 0.47 | 0.00 | 0.27 | 0.00 | 0.00 | 0.00 | 0.00 | 16-17 July n = 5 |
| VAR | 0.00 | 24.42 | 3.87 | 0.00 | 46.76 | 0.42 | 0.00 | 0.36 | 0.00 | 0.00 | 0.00 | 0.00 | n = 5 |
| MEAN | 0.12 | 1.79 | 3.57 | 0.00 | 1.06 | 0.09 | 2.13 | 0.15 | 1.65 | 0.15 | 0.00 | 0.12 | 17-18 July n = 10 |
| VAR | 0.14 | 4.18 | 3.83 | 0.00 | 3.50 | 0.08 | 6.72 | 0.15 | 1.48 | 0.11 | 0.00 | 0.14 | n = 10 |
| MEAN | 0.00 | 2.27 | 4.66 | 0.00 | 2.58 | 0.28 | 2.63 | 0.55 | 1.85 | 0.00 | 0.00 | 0.00 | 18-19 July n = 9 |
| VAR | 0.00 | 3.23 | 17.34 | 0.00 | 7.45 | 0.31 | 11.40 | 1.50 | 3.18 | 0.00 | 0.00 | 0.00 | n = 9 |
| MEAN | 0.39 | 1.00 | 3.16 | 0.00 | 0.00 | 0.00 | 5.88 | 0.08 | 1.76 | 0.00 | 0.52 | 0.00 | 22 July n = 12 |
| VAR | 0.85 | 1.35 | 7.91 | 0.00 | 0.00 | 0.00 | 11.97 | 0.08 | 2.35 | 0.00 | 0.66 | 0.00 | n = 12 |
| MEAN | 0.00 | 1.77 | 5.85 | 0.58 | 0.00 | 0.00 | 7.48 | 0.25 | 2.68 | 0.00 | 0.00 | 0.00 | 23 July n = 12 |
| VAR | 0.00 | 2.00 | 17.98 | 0.99 | 0.00 | 0.00 | 19.28 | 0.20 | 3.46 | 0.00 | 0.00 | 0.00 | n = 12 |
| MEAN | 1.33 | 5.25 | 16.17 | 1.83 | 0.00 | 0.00 | 21.92 | 3.08 | 8.67 | 0.00 | 0.00 | 0.00 | 24 July n = 12 |
| VAR | 2.42 | 20.39 | 164.70 | 1.61 | 0.00 | 0.00 | 137.90 | 10.99 | 41.52 | 0.00 | 0.00 | 0.00 | n = 12 |

Note: All counts are expanded to 15-min observation periods.

Table 4
Mean Smolt Count by Camera Location Among Treatments for Infrasonic Device Tests Conducted in McNary Channel, 1997

| Test | Dates | Treatment | Replicate Hours, n | Mean Count per Hour by Camera Location | | |
|---------------------|-------|-----------|--------------------|--|------------|---------------|
| | | | | Near Screen | Midchannel | Near Far Wall |
| Infrasonic (pump) | 19-24 | ON | 20 | 4.65 | 3.75 | 6.55 |
| | April | OFF | 20 | 4.35 | 3.95 | 5.15 |
| Infrasonic (piston) | 19-21 | ON | 9 | 1.17 | n/a | n/a |
| | July | OFF | 9 | 1.39 | n/a | n/a |

Note: Smolt counts are expanded to full hour coverage.

Infrasonic Surveys

Selected results of low-frequency sound surveys conducted in a smolt transportation barge are shown in Figure 7. Within the transport barge, the greatest mean and maximum sound pressure levels observed were in the frequency bands less than 5 Hz and between 15 and 20 Hz. Mean sound pressure levels at these frequencies were 111 dB referenced to 1 μ Pa at 1 m, with the maximum sound pressure reading of over 170 dB referenced to 1 μ Pa at 1 m for frequencies less than 5 Hz. Maximum sound pressure levels represent a thousand-fold increase over the mean background levels. Maximum sound pressure levels were generally slightly higher closer to the water surface compared with the measurements taken at depth.

Selected results of the low-frequency sound survey conducted in the McNary wet separator are shown in Figure 8. Highest mean and maximum sound pressure levels were found within the frequency bands below 5 Hz, with the maximum sound pressure reading (172 dB referenced to 1 μ Pa at 1 m) much greater than sound pressure levels for all other frequencies. This maximum sound pressure level represents a five-hundred-fold increase over the mean background levels. As with the transport barge surveys, results among all locations surveyed within the wet separator showed little variability for patterns of both sound pressure levels and frequency domain.

Propagation of Infrasonic through Screens

We shipped a 1-m by 1-m section of dewatering screen material to the University of Oslo, Norway, to determine its effect on the sound field produced from an infrasonic device. Simrad, Inc., conducted the experiments using a piston infrasonic device that had been shown to elicit avoidance response in the presence of juvenile salmonids (Knudsen, Enger, and Sand 1992). The results of the propagation through screen experiments as reported by Simrad, Inc.,¹

¹ Personal Communication from R. D. Campana, 1997, "A study on the effect of screen on 12 Hz infrasonic."

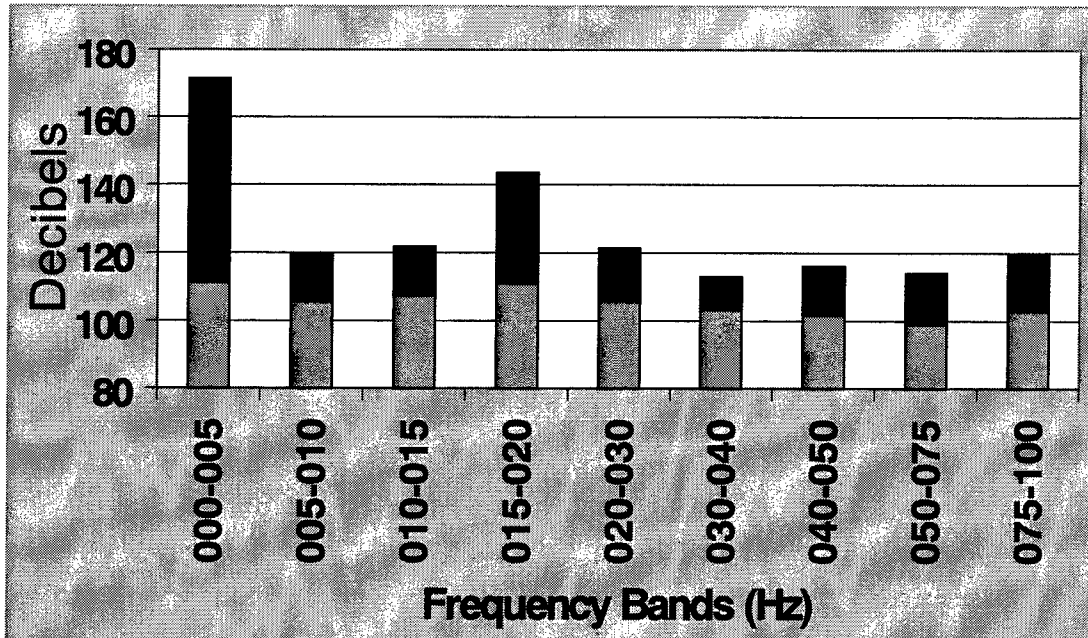

Figure 7. Mean and maximum sound pressure levels recorded from a stationary smolt transport barge below McNary Dam at 0.6-m depth. Decibels are referenced to 1 μ Pa at 1 m

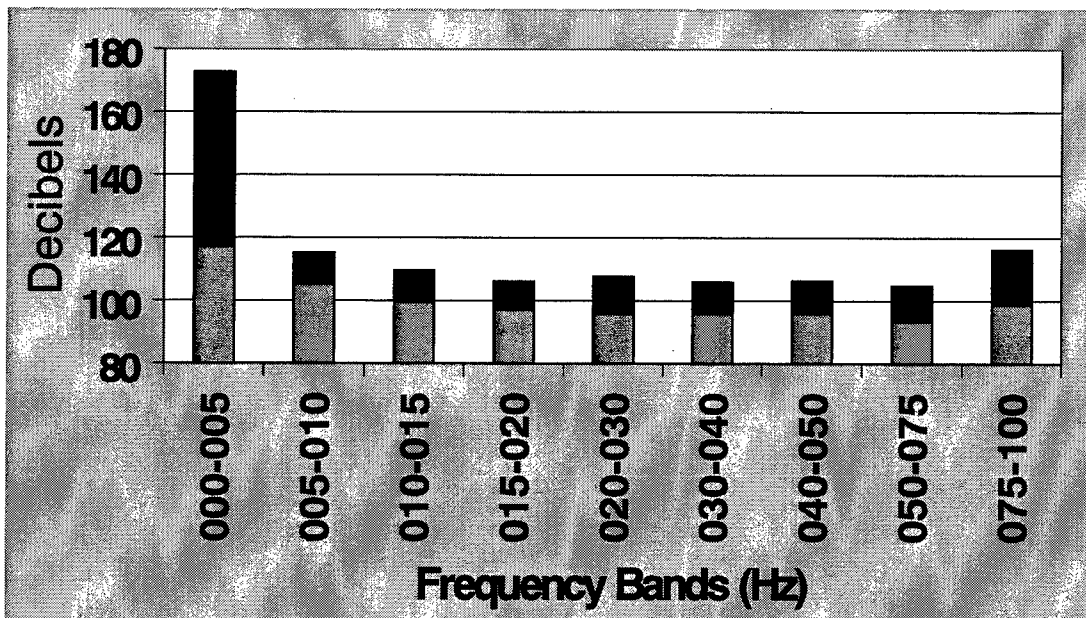

Figure 8. Mean and maximum sound pressure levels recorded from McNary fish separator. Decibels are referenced to 1 μ Pa at 1 m

indicated that screening material had a small effect on the performance of the infrasonic device.

Holding Behavior

In collaboration with the U.S. Army Engineer Waterways Experiment Station, the U.S. Geological Survey's Columbia River Research Laboratory released a total of 45 radio-tagged chinook and steelhead smolts to determine the presence and extent of holding behavior associated with behavioral device testing. We anticipated two potential sources contributing to holding behavior: (a) velocity refugia immediately downchannel from the behavioral devices; and (b) the presence of the light and sound stimuli.

The fish were obtained from the fish collection facility at McNary and released into the bypass channel at turbine unit 7A about 183 m upchannel from the location of device deployment. Fifteen fish were released during a control period, and 15 fish were released during on treatments of both strobe lights and infrasound. Two groups of underwater dipole antennae were deployed in the channel (Figure 9). The first group comprised six antennae spaced 27.4 m apart extending 121.9 m above and 15.2 m below the behavioral device testing location. These antennae were designed to determine rate of fish movement down the channel. The second group consisted of one antenna positioned immediately upstream of the test devices and two additional antennae downstream on opposite sides of the collection channel. The upstream antenna was designed to detect delays in the vicinity of the test devices while the other two were intended to determine travel location.

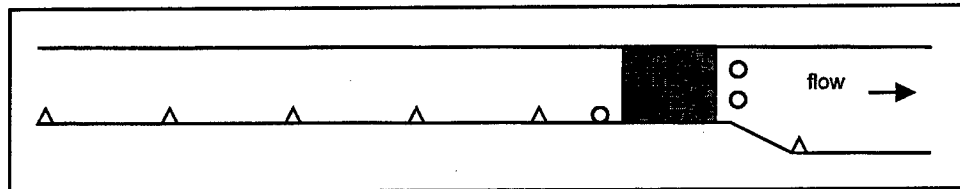

Figure 9. Plan view of a section of the McNary juvenile bypass channel showing radio-telemetry antennae locations. Antennae are indicated as triangles for general monitoring and rate of travel, or circles for specific monitoring near the test devices (shaded area). General monitoring antennae upchannel from the test devices were spaced 27 m apart. Drawing not to scale.

One-way analysis of variance revealed no significant differences in the overall rate of travel through the collection channel between treatment and control groups. Chi-square testing indicated no significant differences in the distribution of fish across the channel.

4 Discussion

Baseline information of lateral smolt distributions in the McNary bypass during control periods indicates that smolts are passing through the channel in greatest numbers along the eastern third of the bypass (Table 1). This may reflect avoidance of the side dewatering screens or that perhaps smolts guide along the first structure encountered (east wall) after plunging from the orifices. A more likely explanation may be that the majority of smolts simply do not distribute laterally after being deposited along the east wall. In any case, the pattern of smolt distribution argues against the notion that side dewatering screens are fish impingement hazards in the McNary channel. When feasible, designers of future side dewatering systems should consider the potential benefits of locating orifices on the same side of the channel as dewatering screens so that fish enter the channel away from screens. We do not know for certain why fish distributions across the McNary bypass channel were strongly skewed away from dewatering screens. However, we believe that having orifice jets depositing fish on the opposite side of the channel is the most likely explanation.

FY 97 efforts to evaluate behavioral device technology for redistributing smolts from the side dewatering system in the McNary JBS were confounded by two factors: sampling gear limitations and a skewed lateral distribution of passing smolts toward the east channel wall. Increased debris loading and greater than normal turbidity conditions caused by the high water year of 1997 reduced the effective imaging volume of the underwater cameras. This limitation, coupled with the fact that the majority of migrating smolts pass through the channel along its eastern third, contributed to some of the inconclusive test results. Consequently, counts based on near-screen underwater cameras were not sufficient to evaluate differences among on/off treatments.

Separate tests of two different particle motion generators resulted in unsuccessful redistribution of migrant juvenile salmonids in the McNary bypass. Similarly, unsuccessful results were achieved this year in infrasound testing in experimental net pens at the Hiram M. Chittenden Locks, Seattle, WA (Ploskey et al., in preparation). Given the positive results of infrasound testing reported by Knudsen, Enger, and Sand (1992) and the negative results reported in Ploskey et al. (in preparation), it becomes obvious that not all infrasound devices generate the same signals. Avoidance responses will not necessarily be achieved just because a sound source resonates at frequencies below 20 Hz.

Infrasound surveys revealed the presence of low-frequency sound in both the McNary wet separator and environments within the smolt transportation barge.

In both cases, observed infrasound pressure levels are high enough to suggest that juvenile salmonid behavior may be affected in some form. Infrasound generated at the wet separator may induce avoidance and thus contribute to holding upchannel. The source of infrasound observed in the fish barge likely is related to the barge engine, which idles at low rpm's in the stationary position. However, during transit a likely source of infrasound is the effect of water pounding against the barge tank walls, resulting in a resonance in the holding bays not unlike a huge drum.

The smolt passage swimming behavior model of backing down tail first without changing range laterally was modified dramatically during strobe light-on treatment observations. In almost all cases, smolts were seen to orient themselves in a head-first with-the-flow position regardless of whether they changed range laterally. Fleeing behavior such as this suggests a rather instinctive avoidance response to strobe light that should be advantageous in reducing holding behavior.

The success of strobe lights for redistributing juvenile smolts from near-screen areas depends upon how you define success. If success is measured solely by smolts observed to swim in a lateral direction away from the stimulus, then strobe lights could be viewed as moderately successful, with 60 percent of smolts in the spring and 40 percent in the summer observed to swim toward the far wall opposite the dewatering screens. If strobe light success is defined by including those smolts observed to turn and swim with the flow, allowing for accelerated swimming downstream and thus decreased exposure time to dewatering screens, then strobe lights should be viewed as highly successful. Proportions of smolt observed to flee in the direction away from the strobe light stimulus or increase swimming speed downstream were 90 percent in spring and 80 percent in summer.

Given the reduced proportion of springtime migrant smolts observed near the screened wall (19 percent), dispersal of over half of these fish will leave only about 10 percent of the passing migrants vulnerable to screen impingement. Essentially, with the combination of passage preference along the east wall and strobe light stimuli behind the screens, one could expect impingement hazards to be eliminated for 90 percent of migrant smolt.

5 Conclusions and Recommendations

Evaluation of behavioral technologies for redistributing juvenile salmonids in the McNary JBS resulted in both positive and inconclusive results. Due to insufficient underwater camera smolt counts, results of strobe light and infrasound testing for dispersing migrant smolts away from side dewatering screens should be considered inconclusive. However, based upon observations of near-surface smolts in the presence of strobe fields, strobe lights greatly modified the swimming behavior of yearling and subyearling migrant smolts. Over 96 percent of yearling and 99 percent of subyearling smolts changed their orientation and/or swimming direction after encountering strobe light stimulus. The implications of such successful behavioral modification are immense, especially for applications in collection and bypass channels where smolt holding is problematic. The results of the overhead observations suggest that strobe lights will be very effective in reducing and preventing holding of smolt in flowing environments and thus contribute to quicker and more efficient passage.

Infrasound testing did not yield promising results as the strobe light evaluations did, but due to the inconsistent nature of the results, it is premature at this point to completely reject infrasound as a behavioral modifier. Investigation into the characterization and prevalence of existing infrasound sources in and around hydropower projects needs to be continued to fully understand the effect of infrasound on fish passage behavior. As reported by Johnson et al. (in preparation) and herein, infrasound is prevalent in the McNary bypass but its effect on smolt passage is unknown.

References

- Anderson, J. J., Puckett, K. J., and Nemeth, R. S. (1988). "Studies on the effect of behavior on fish guidance efficiency at Rocky Reach Dam: Avoidance to strobe light and other stimuli," Report FRI-UW-8801, Fisheries Research Institute, University of Washington, Seattle, WA.
- Carlson, T. J. (1994). "Use of sound for protection at power production facilities: A historical perspective of the state of the art; Phase 1, Final Report under Task Order 49432: Evaluation of the use of sound to modify the behavior of fish," Prepared for the U.S. Department of Energy, Bonneville Power Administration, Portland, OR.
- Craddock, D. R. (1956). "A review of studies in guiding downstream migrating salmon with light," *Progress report on Fisheries Engineering Research Program*, U.S. Army Engineer Division, North Pacific, Portland, OR, pp 1-13.
- Dunning, D. J., Ross, Q. E., Geoghegan, P., Reichle, J., Menezes, J. K., and Watson, J. K. (1992). "Alewives in a cage avoid high-frequency sound," *N. Am. J. Fish. Manage.* 12:407-416.
- Fields, P. E., Murray, A. K., Johnson, D. E., and Finger, G. L. (1958). "Guiding migrant salmon by light repulsion and attraction in fast and turbid water," Technical Reports No. 36 and 41, College of Fisheries, University of Washington, Seattle, WA.
- Johnson, P. N., Ploskey, G. R., Carlson, T. J., Nestler, J. M., and Evans, J. "Feasibility study for evaluating redistribution of juvenile salmon in the McNary bypass channel using behavioral technologies: 1996" (in preparation), U.S. Army Engineer Waterways Experiment Station, Vicksburg, MS.
- Knudsen, F. R., and Schreck, C. "Use of infrasound to guide juvenile salmonids" (in preparation), U.S. Army Engineer Waterways Experiment Station, Vicksburg, MS.
- Knudsen, F. R., Enger, P. S., and Sand, O. (1992). "Awareness reactions and avoidance responses to sound in juvenile Atlantic Salmon, *Salmo salar*," *J. Fish Biol.* 40:523-534.

- McKinley, R. S., and Patrick, P. H. (1988). "Use of behavioral stimuli to divert sockeye salmon smolts at the Seton Hydro-electric Station, British Columbia." *Proceedings: Fish protection at steam and hydroelectric power plants*, San Francisco, CA, October 28-30, 1987. EPRI CS/EA/AD-5663-SR, Electric Power Research Institute, Palo Alto, CA.
- Mueller, R. P., Neitzel, D. A., Mavros, W. V., and Carlson, T. J. (1998). "Evaluation of low and high frequency sound for enhancing the capacity of fish screening facilities to protect outmigrating salmonids," performed under Contract No. DE-A 179-86BP62611 for Bonneville Power Administration, Portland, OR.
- Nemeth, R. S. (1989). "The photobehavior responses of juvenile chinook and coho salmon to strobe and mercury lights," M.S. Thesis, University of Washington, Seattle.
- Nemeth, R. S., and Anderson, J. J. (1992). "Response of juvenile coho and chinook salmon to strobe and mercury lights," *N. Am. J. of Fish. Manage.* 12(4), 684-692.
- Nestler, J. M., Ploskey, G. R., Pickens, J., Menezes, J., and Schilt, C. (1992). "Responses of blueback herring to high-frequency sound with implications for reducing entrainment at hydropower dams," *N. Am. J. Fish. Manage.* 12:667-683.
- Nestler, J. M., George, J., Ahmad, F., Carlson, T. J. (1994). "Developing acoustic technologies for improving fish passage and protection in the Columbia River Basin: Program Rationale," Technical Report EL-95-8, U.S. Army Engineer Waterways Experiment Station, Vicksburg, MS.
- Ploskey, G. R., Pickens, J. L., and Weeks, G. N. (1994). "Behavioral responses of anadromous blueback herring and American shad to high frequency sound, flow, and a wing wall in St. Stephen Tailrace, South Carolina," Technical Report EL-94-7, U.S. Army Engineer Waterways Experiment Station, Vicksburg, MS.
- Ploskey, G. R., Nestler, J. M., Weeks, G. N., and Schilt, C. (1995). "Evaluation of an integrated fish-protection system," *Waterpower*, Proceedings of the 1995 International Conference on Hydropower, San Francisco, CA, July 25-28, 1995. J. J. Cassidy, ed., American Society of Civil Engineers, New York, 162-171.
- Ploskey, G. R., Johnson, P. N., Burczynski, M. G., Nestler, J. N., and Carlson, T. J. "Effectiveness of strobe lights, infrasound devices and a sound transducer for eliciting avoidance by juvenile salmonids" (in preparation), U.S. Army Engineer Waterways Experiment Station, Vicksburg, MS.
- Puckett, K. J., and Anderson, J. J. (1987). "Behavioral responses of juvenile salmonids to strobe and mercury lights," Report No. FRI-UW-8717, Fisheries Research Institute, University of Washington, Seattle, WA.

- Ross, Q. E., Dunning, D. J., Thorne, R., Menezes, J. K., Tiller, G. W., and Watson, J. K. (1993). "Response of alewives to high-frequency sound at a power plant on Lake Ontario," *N. Am. J. Fish. Manage.* 13:291-303.
- Taft, E. P., Winchell, F. C., Amaral, S. V., Brown, N. A., Ronafalvy, J. P., and Haberland, M. W. (1995). "Recent advances in sonic fish deterrence." *Waterpower*, Proceedings of the 1995 International Conference on Hydropower, San Francisco, CA, July 25-28, 1995. J. J. Cassidy, ed., American Society of Civil Engineers, New York, 1724-1733.
- Winchell, F. C., Amaral, S. V., Taft, E. P. (1994). "Research update on fish protection technologies for water intakes," Research Report TR-104122, Electric Power Research Institute, Palo Alto, CA.

REPORT DOCUMENTATION PAGE

Form Approved
OMB No. 0704-0188

Public reporting burden for this collection of information is estimated to average 1 hour per response, including the time for reviewing instructions, searching existing data sources, gathering and maintaining the data needed, and completing and reviewing the collection of information. Send comments regarding this burden estimate or any other aspect of this collection of information, including suggestions for reducing this burden, to Washington Headquarters Services, Directorate for Information Operations and Reports, 1215 Jefferson Davis Highway, Suite 1204, Arlington, VA 22202-4302, and to the Office of Management and Budget, Paperwork Reduction Project (0704-0188), Washington, DC 20503.

| | | | | |
|---|---|--|--|--|
| 1. AGENCY USE ONLY (Leave blank) | | 2. REPORT DATE December 1998 | 3. REPORT TYPE AND DATES COVERED Final report | |
| 4. TITLE AND SUBTITLE Evaluation of Infrasound and Strobe Lights for Redistributing Migrant Salmon Smolts in the McNary Juvenile Bypass: 1997 | | | 5. FUNDING NUMBERS | |
| 6. AUTHOR(S) Peter N. Johnson, Gene R. Ploskey | | | | |
| 7. PERFORMING ORGANIZATION NAME(S) AND ADDRESS(ES) ASCI Corporation 1365 Beverly Road, McLean, VA 22101 U.S. Army Engineer Waterways Experiment Station 3909 Halls Ferry Road, Vicksburg, MS 39180-6199 | | | 8. PERFORMING ORGANIZATION REPORT NUMBER Technical Report EL-98-17 | |
| 9. SPONSORING/MONITORING AGENCY NAME(S) AND ADDRESS(ES) U.S. Army Engineer District, Walla Walla 201 North Third Avenue Walla Walla, WA 99362-1876 | | | 10. SPONSORING/MONITORING AGENCY REPORT NUMBER | |
| 11. SUPPLEMENTARY NOTES Available from National Technical Information Service, 5285 Port Royal Road, Springfield, VA 22161. | | | | |
| 12a. DISTRIBUTION/AVAILABILITY STATEMENT Approved for public release; distribution is unlimited. | | | 12b. DISTRIBUTION CODE | |
| 13. ABSTRACT (Maximum 200 words) We assessed the use of infrasound and strobe lights for redistributing yearling and subyearling migrant salmonids away from dewatering screens in the McNary Juvenile Bypass System. Infrasound signals were generated using two devices: a pump with a rotary valve and reciprocating pistons. We evaluated the former device operating at 20 Hz in spring based upon differences in mean counts of migrant smolts across the channel during hourly sound-on and sound-off treatments (n=20). We evaluated the piston device operating at about 8 Hz in summer based on differences in mean counts of migrant smolts near the side dewatering screen during hourly sound-on and sound-off treatments (n=9). We also tested three separate strobe light applications. In spring, we initially installed one strobe head (Flash Technologies AGL Series) in midchannel at the elevation of the top screen panels and aimed it toward the screened wall. Later in the spring, we deployed two strobe heads on the screened wall 4.3 and 7.3 m upchannel, respectively, from the downstream edge of the side dewatering screens. We evaluated effectiveness by comparing mean counts of migrant smolts across the channel during hourly strobe-on and strobe-off treatments (n=18 for both applications). In summer, we installed two strobe heads behind the dewatering screens 7.3 and 11 m upchannel, respectively, from the downstream edge of the side dewatering screens. We evaluated performance based on differences in mean counts of smolts near the side dewatering screen during (Continued) | | | | |
| 14. SUBJECT TERMS Bypass technologies Juvenile bypass system Surface collector technology Columbia River dams McNary Dam Infrasound Strobe lights | | | 15. NUMBER OF PAGES 30 | |
| | | | 16. PRICE CODE | |
| 17. SECURITY CLASSIFICATION OF REPORT UNCLASSIFIED | 18. SECURITY CLASSIFICATION OF THIS PAGE UNCLASSIFIED | 19. SECURITY CLASSIFICATION OF ABSTRACT | 20. LIMITATION OF ABSTRACT | |

13. (Concluded).

hourly strobe-on and strobe-off treatments (n=18). Distributions and counts of smolts were monitored during behavioral device tests using high-resolution underwater cameras. Releases and tracking of radio-tagged smolts by the National Biological Service revealed that none of the behavioral devices increased passage time through the channel or caused significant holding.

Results based upon counts of smolts with underwater cameras were inconclusive because of limited visibility resulting from high water in the Columbia River in 1997 and a highly skewed lateral distribution of fish toward the east wall opposite side dewatering screens during both on and off treatments. Over 80 percent of smolts were in midchannel or the east half of the channel and counts near screens were consistently low. This skewed distribution likely reflects the positive aspect of having orifices or other channel openings located on the same side of the channel as side dewatering screens so that fish enter the channel as far away from screens as possible. Statistical comparisons of hourly on or off counts averaging one or two fish are meaningless since a single fish detection can alter results by 50 percent. However, we were able to evaluate the effectiveness of strobe lights because strobe flashes backlighted smolts passing through lighted areas and provided ample numbers to describe and evaluate behavioral changes. During strobe light treatments, smolts avoided strobe lights by moving toward the wall opposite dewatering screens (50 percent in spring and 42 percent in summer) or by turning 180 deg and swimming rapidly downstream with the 1.1-m/sec (3.5-fps) flow. The proportion of smolts exhibiting change in lateral range and/or increased swimming speed downstream was 90 percent in the spring and 80 percent in the summer. Clearly, strobe lights can be valuable for efficiently moving smolts through dewatering areas and for eliminating smolt holding behavior in bypass channels. Changing the location of lights from midchannel where they were aimed upstream and toward screens to a location on or behind screens was critical for successful application. Lights on or behind screens flashed light into the left eye of smolts that were backing down the channel and usually elicited avoidance away from screens (across channel or downstream). Midchannel lights flashed smolts from the tail aspect and may have been an ambiguous stimulus.

We conducted sound surveys in a stationary smolt transport barge and in the McNary fish separator to measure and characterize ambient infrasounds. In both locations, we recorded the presence of sound fields with frequencies of 20 Hz and below. We noted that frequencies below 5 Hz contained the greatest mean and maximum sound pressure levels. The transport barge had a mean sound pressure level of 111 dB referenced to 1 μ Pa at 1 m and a maximum of 172 dB at frequencies between 0 and 5 Hz. Sound pressure levels > 9 dB above the minimum background levels can be detected by smolts and those > 170 dB are more than 500 times as loud as the background noise.