

TNO report  
PML 1998-A39

# Development of an instrument to measure the close-in impulse load of a fragmenting charge.

## Progress report 1. Design and testing of prototype

TNO Prins Maurits Laboratory

Lange Kleiweg 137  
P.O. Box 45  
2280 AA Rijswijk  
The Netherlands

Phone +31 15 284 28 42  
Fax +31 15 284 39 58

Date  
November 1998

~~ONGERUBRICEERD~~

Author(s)  
R.M.M. van Wees

Classification  
Classified by : D. Boon  
Classification date : 3 November 1998  
(this classification will not change)

Title : Ongerubrificeerd  
Managementuitreksel : Ongerubrificeerd  
Abstract : Ongerubrificeerd  
Report text : Ongerubrificeerd

19990112 083

All rights reserved.  
No part of this publication may be reproduced and/or published by print, photoprint, microfilm or any other means without the previous written consent of TNO.

In case this report was drafted on instructions, the rights and obligations of contracting parties are subject to either the Standard Conditions for Research Instructions given to TNO, or the relevant agreement concluded between the contracting parties.  
Submitting the report for inspection to parties who have a direct interest is permitted.

Copy no. : 12  
No. of copies : 24  
No. of pages : 23 (excl. RDP & distribution list)  
No. of annexes : -

All information which is classified according to Dutch regulations shall be treated by the recipient in the same way as classified information of corresponding value in his own country. No part of this information will be disclosed to any party.

The classification designation Ongerubrificeerd is equivalent to Unclassified.

© 1998 TNO

TNO Prins Maurits Laboratory is part of  
TNO Defence Research which further consists of:



TNO Physics and Electronics Laboratory  
TNO Human Factors Research Institute

A9F99-04-05 83

Netherlands Organization for  
Applied Scientific Research (TNO)

## Managementuittreksel

Titel : Development of an instrument to measure the close-in impulse load of a fragmenting charge.  
Progress report 1. Design and testing of prototype

Auteur(s) : Ir. R.M.M. van Wees

Datum : november 1998

Opdrachtnr. : B97D427

Rapportnr. : PML 1998-A39

Er bestaat de behoefte om de explosie-effecten van fragmenterende ladingen te meten op korte afstand van de detonatie. Deze vraag komt voornamelijk uit het humanitair ontminnen, waarvoor mijnbestendige voertuigen en apparatuur nodig zijn. Het probleem is dat de impulsbelasting van de gecombineerde fragment- en blastbelasting onbekend is. Er bestaan geen gevalideerde berekeningscodes en ook geen experimentele methoden. Het doel van de studie is een instrument te ontwikkelen dat die impulsbelasting kan meten.

Dit voortgangsverslag behandelt de eerste fase van het project: de literatuurstudie en het ontwerpen en testen van het prototype.

Het gekozen meetprincipe is een zogenaamde impulse plug (een speciale uitvoering van een ballistische slinger). Hieraan is een eigen idee toegevoegd om de blastimpuls te scheiden van de fragmentimpuls. Uit de testen met het prototype bleek dat het basisprincipe werkte, zelfs op 20 cm van een fragmenterende lading van 200 gram. Ook bleek dat het ontwerp nog op diverse punten verbeterd kan worden.

Aanbevolen wordt om in de tweede fase van dit project verder te gaan met het concept van de impulse plug en een ontwerp te maken waarin de opgedane ervaringen verwerkt zijn. Verwacht wordt dat het ontwerp een praktisch inzetbaar instrument oplevert.

## Contents

Managementuittreksel .....	2
1 Introduction .....	4
2 Potential ways to measure a mine load .....	5
2.1 Ballistic pendulum, impulse plug .....	5
2.2 Fragment protected pressure transducer .....	6
2.3 Yb gauges .....	7
2.4 Hopkinson bar .....	9
2.5 Choice of best concept .....	9
3 Design of the prototype .....	10
3.1 New idea to separate blast from fragment load .....	10
3.2 Requirements .....	10
3.3 Description of the prototype .....	11
4 Testing of the prototype .....	16
5 Conclusions .....	21
6 Recommendations .....	21
7 References .....	22
8 Authentication .....	23

## 1 Introduction

There exists a demand to measure the close-in explosion effects of fragmenting charges. This demand comes from various sources, but in particular from TNO's increased activities in humanitarian demining. The problem there is to design mine-resistant vehicles and equipment which will be exposed to blast and fragments, at very close proximities to the charge. Two effects take place: penetration of fragments and the impulse load that is generated by the blast and the fragments. The impulse load can dent plates and break welds. Its magnitude is unknown. It cannot be predicted well and it cannot be measured well. Current hydrocodes use models which can predict fragment formation reasonably well but make poor airblast predictions [Drotleff et al., 1996]. Current measurement equipment does not survive in such a hostile environment. In addition, the explosion effects are stochastic: the airblast is very turbulent because one is inside the fireball and the fragment load is inherently variable.

The purpose of this study is to design an instrument which can measure the combined blast and fragment load. It should preferably be able to generate data which are both directly usable for design purposes and to validate hydrocodes.

The study begins with a literature study, followed by the design, building and testing of a prototype. Subsequently, the final instrument is designed, built and tested. This progress report covers the literature study and development of the prototype.

## 2 Potential ways to measure a mine load

A number of ways are potentially suitable to measure the loads from a mine blast. The literature was searched for experiences with these techniques and for any new techniques. A list of the most relevant literature is given in the References. The potential measurement techniques are listed below.

### 2.1 Ballistic pendulum, impulse plug

The principle of a ballistic pendulum and of an impulse plug is to expose a well-defined area of a heavy mass to the blast and fragment load. Newton's law of conservation applies, so the velocity of the mass is a measure of the combined blast and fragment load. In formula:

$$i_{blast} A_{mass} + \sum(m_{frag}) v_{frag} = (m_{mass} + \sum m_{frag}) v_{mass} \quad (1)$$

where:

$A_{mass}$	exposed area of the ballistic pendulum or impulse plug	m <sup>2</sup>
$i_{blast}$	average impulse of the blast wave	Pa.s
$m_{frag}$	mass of a fragment	kg
$m_{mass}$	mass of the ballistic pendulum or impulse plug	kg
$v_{frag}$	average fragment velocity	m/s
$v_{mass}$	velocity of the ballistic pendulum or impulse plug	m/s

The mass is so heavy that it does not move appreciably during the application of the load. This does not take much at close ranges, because the load duration is so short. The mass is usually guided, so it can move in only one direction. The velocity can be measured in several ways. Ballistic pendulums are suspended and their maximum swing is recorded. Impulse plugs are often short metal rods that are placed in a hole in a wall. Their velocity can be measured by time-of-flight measurement over a defined distance, high-speed video and various other methods. In cases where the mass is unguided, the velocity is commonly recorded by high-speed video.

Ballistic pendulums and impulse plugs have the advantage that they are robust systems, relatively inexpensive, and they can measure a combined blast and fragment load. Their disadvantage is that they can only measure the total momentum of the load, not the entire load-history.

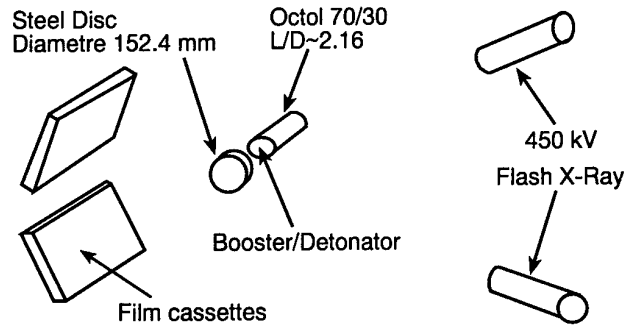


Figure 2.1: Example of a free-flying mass. In this case, the mass is a steel disc and the velocity is recorded by taking several flash X-ray photos. [Weaver and Walters, 1982].



Figure 2.2: Example of a ballistic pendulum. This one is a roller pendulum for measuring combined fragment-blast impulses [Mehlin and Parr, 1982].

## 2.2 Fragment protected pressure transducer

Normal pressure gauges have two shortcomings when it comes to measuring close-in blast loads. One, they are very vulnerable to fragment impact; even a tiny particle will ruin these expensive instruments. Two, their range is limited. Versions that can cope with the extremely high pressures close to a charge do not exist. To overcome the first shortcoming, pressure gauges are sometimes placed behind a shield; for example, behind a piece of steel corner profile placed a few centimetres in front of the gauge. Unfortunately, such measures always influence the blast. Another option is to record only side-on blast. In that case the pressure transducer no longer faces the charge. An encasement, such as a blast pencil or a skimmer plate can protect the instrument.

Thus, the disadvantages of fragment protected pressure transducers are: that they can only measure blast loads, not fragment loads; that they have a too limited range to measure close-in blast; that they cannot measure reflected pressure without disturbing the blast. The advantage is that they can measure the complete pressure history and that they are standard systems, commercially available.

### 2.3 Yb gauges

Ytterbium gauges resemble strain gauges in appearance. However, they do not measure elongation of their surface, but pressure on their surface. Their resistance changes when a pressure is applied. They are members of a family of piezoresistant stress gauges. Other examples are manganin gauges and carbon gauges. These operate at higher pressures; for example, the detonation pressure inside an explosive. Ytterbium gauges are suitable for the pressure range that is found close to an explosion. They are mounted between insulating layers and can be protected by a thin steel strip. Thus, they can be protected against (very) small fragments. Their advantage is that they can measure the complete pressure history and that they can measure very high pressures. Their disadvantage is that they can only measure blast loads, not fragment loads.

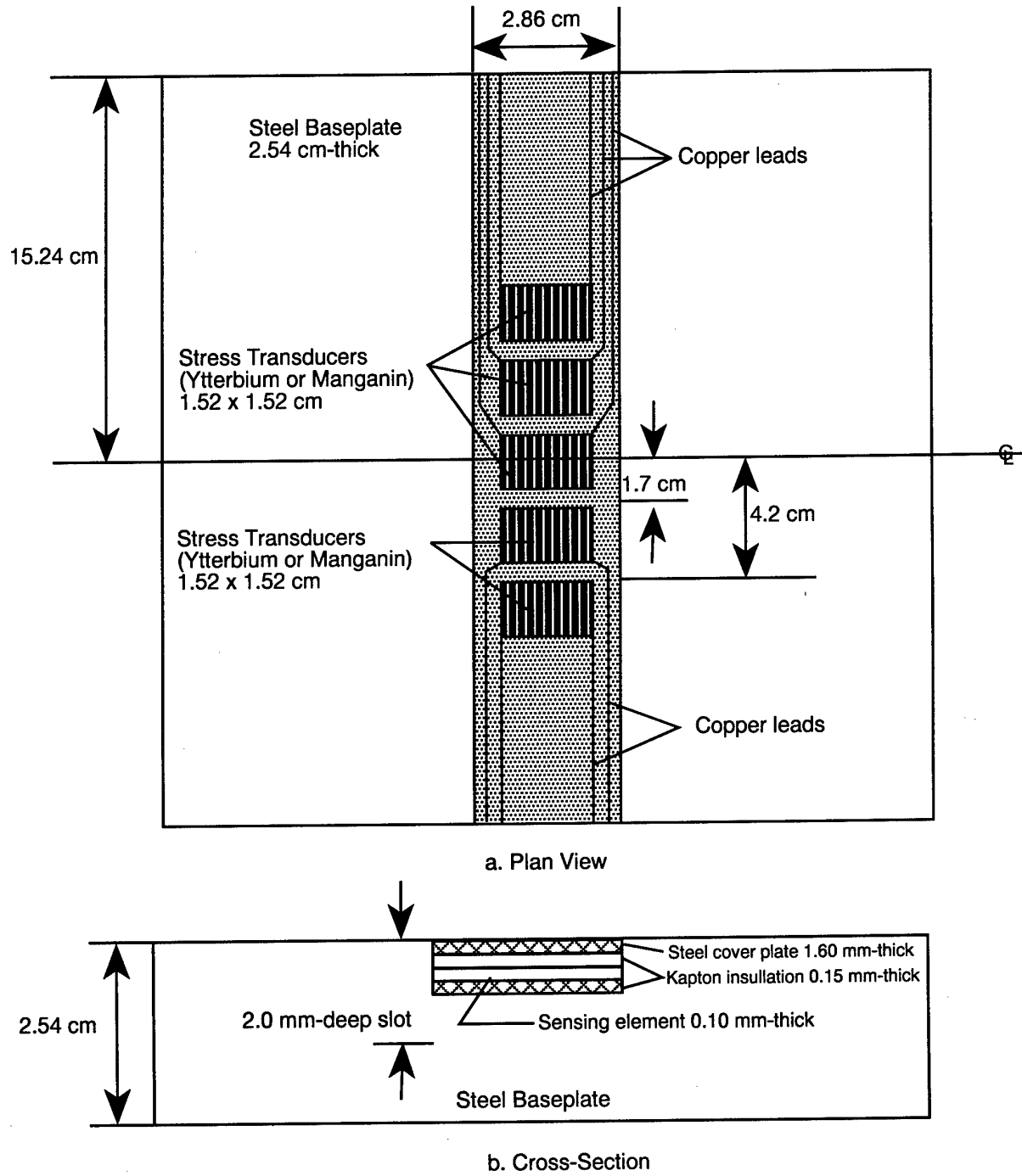


Figure 2.3: Example of a mounted Yb gauge [Drotleff et al., 1996].

## **2.4 Hopkinson bar**

A Hopkinson bar is a long slender metal rod. It is most often used as a loading device for high strain-rate tests, but it can also be used as a measuring device. In that configuration, the blast and fragments hit one face, which generates a stress wave in the rod. The stress wave travels down the rod and is measured by strain gauges. The rod must be long enough to hold the stress wave of the entire load history, otherwise the stress wave would reflect from the other end of the rod and the signal would become impossible to interpret.

Its advantages are that it can measure both blast loads and fragment loads, and it can operate at close range. Its disadvantage is that the signal is difficult to interpret because the stress wave distorts as it travels down the rod. The literature reported only one successful application of the Hopkinson bar as a measuring device. Another practical disadvantage is that it is a long object, which can be hard to fit in the test set-up.

## **2.5 Choice of best concept**

From all potential ways to measure a mine load, an impulse plug appeared to be the most promising concept. It has the potential to measure a combined blast and fragment load. It has a much better track record than a Hopkinson bar. It does the same as a ballistic pendulum but is much smaller and therefore much easier to apply. For example, it is conceivable to fit an impulse plug in the belly of a tank.

### 3 Design of the prototype

This chapter describes the design of the prototype of the impulse plug. It starts by explaining a new idea that is incorporated in the design. Next, the requirements for the design are listed and finally the design and its operation are described.

#### 3.1 New idea to separate blast from fragment load

It occurred to us that it should be possible to extract more information from an impulse plug than just the combined load of blast and fragments. With a suitable set-up of the experiment, one could separate the blast load from the fragment load. Look again at equation 1 in Section 2.1. There are only two variables that cannot directly be measured; the average blast impulse and the average fragment velocity. This makes one equation with two unknowns, and that cannot be solved. However, if a number of experiments are performed, a system of equations is formed. Then, the average blast impulse and the average fragment velocity can be solved. This can only be done if the system of equations is independent, that is, if they are not all the same. Thus, the mass of fragments that is caught should vary from shot to shot. This will happen naturally in most experiments. Also, multiple experiments are usually required anyway, so this method does not require extra work.

#### 3.2 Requirements

Before the prototype of the impulse plug was designed, first a list of requirements was drawn up. These requirements described the loads that the prototype was to be designed to measure, the thickness of the material to withstand penetration, the requirements that generic instrumentation would have and numerous other points. The most important requirements are listed below.

- Load  
The most likely application of an impulse plug is to measure the load of a mine on a vehicle. Typical situations are an AT blast mine under the vehicle's belly and a fragmenting AP mine in a wheel bay. It was decided to design the prototype for the latter situation: a 0.6 kg TNT charge with a 5 kg casing, at a stand-off distance of 20 cm. Later, this turned out to be a mistake, since the prototype was tested with much lighter loads. Thus, the test would only generate a low signal.
- Proper measurement of load  
For a proper measurement of the blast load, the same load must load the entire surface. The consequence for the 0.6 kg charge at 20 cm is that the blast wave must impinge on a plane of about 0.5 m wide. This is enough to prevent diffraction effects from reaching the impulse plug. For a proper measurement of

the fragment momentum, the fragments must be caught without reflecting them backwards and no material may be ejected.

- **Robustness**

The prototype was to be designed to withstand fragments with a maximum penetrating capability of 20 mm mild steel. Parts should either be able to withstand these, be shielded from fragments, or be easily replaceable. The design should shield the instrumentation and cabling against the explosion effects.

- **Ease of use**

The prototype was already to be designed as if it was to be used in a real experimental set-up. This included limits on mass (for transportability) and attention to ease of operation; this means all operations, from calibration to signal processing.

- **Accuracy**

Because the load is highly variable at close range, a high accuracy of the measurement is not warranted. It is estimated that a 10 to 30% accuracy is acceptable.

### **3.3 Description of the prototype**

The prototype was designed and manufactured quickly, in less than two months. Figures 3.1 to 3.6 show drawings and pictures of it. Basically, it is a piston moving in a tube. The piston acts as the mass of the impulse plug and the tube guides its movement. Figure 3.2 shows the piston. The front part is made of nylon and is intended to catch all fragments. Because it will be damaged, it is made replaceable. It is attached with three bolts to a steel part.

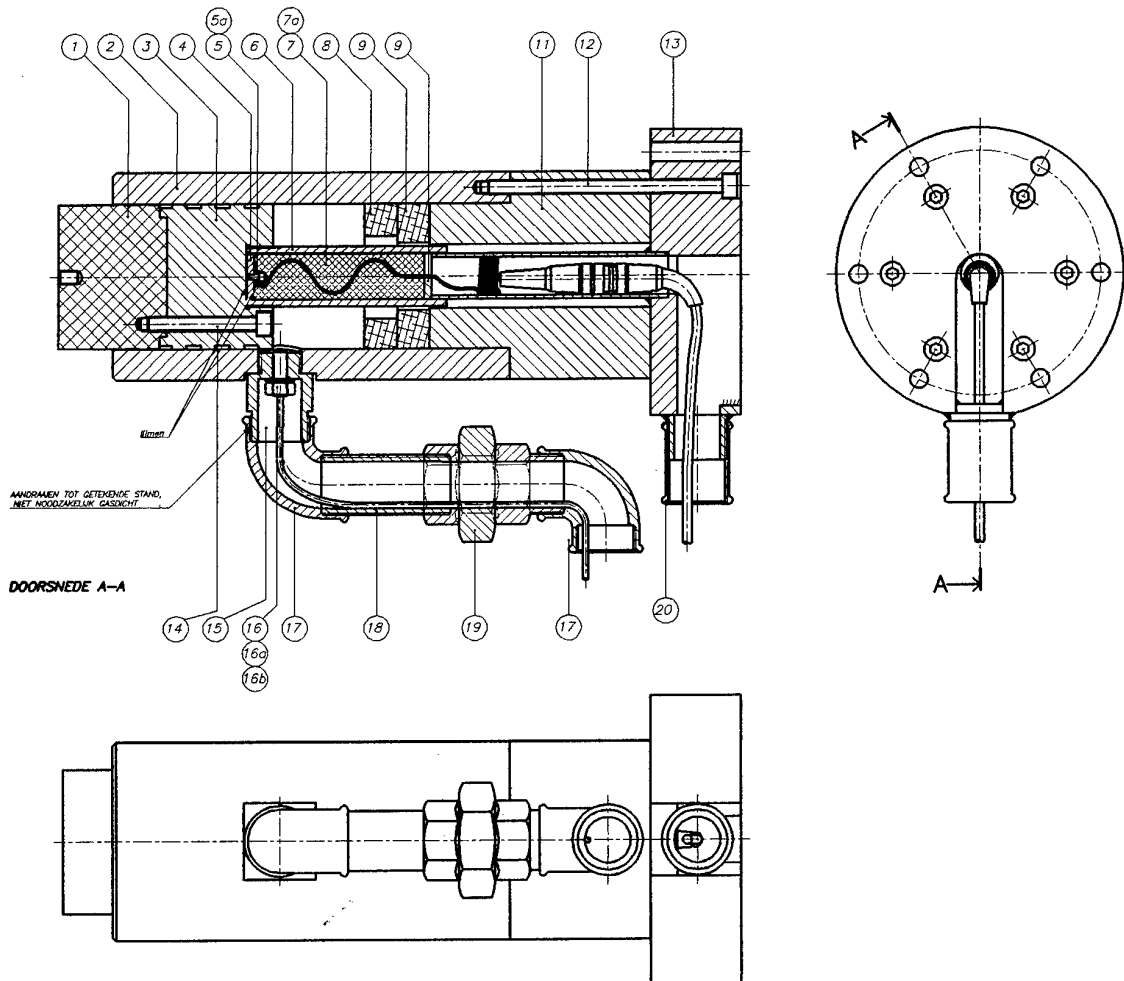
Before the experiment, a 'table' is placed over the impulse plug, as Figure 3.4 shows. This table creates a smooth reflected blast. It also offers protection against the fragments, because it only allows fragments to strike the front face of the impulse plug. At that face, the fragments penetrate in the nylon and get stuck. The piston is accelerated due to the combined load of the fragments and the blast. This occurs in a very short time, so for practical purposes it can be assumed that the piston is instantaneously accelerated to its maximum velocity.

This velocity is measured. It was decided to try out two completely different methods. The first method uses an accelerometer at the base of the piston. The actual acceleration of the piston is too high to measure and therefore the accelerometer is mounted on a shock mount. This is essentially a spring. Thus, the accelerometer follows the movement of the piston after a short delay. The velocity is later found by integrating the acceleration signal. One practical complication of this method was that the cable of the accelerometer had to be guided and to be protected from tensile forces. To accomplish this, it was enclosed in a tube filled with foam rubber. The second method used a time-of-flight measurement. The steel part of the piston was grooved and a transducer was placed in the wall of the tube to detect the passage of the grooves. The times of the passages simply give the velocity. Note

however that this is the relative velocity of the piston to the tube. This means that the entire instrument must be mounted rigidly.

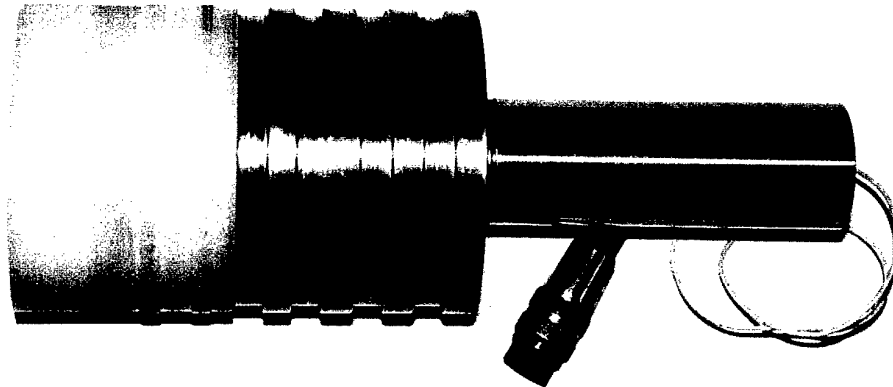
At the end of the stroke, the piston must be stopped without further damage. This is done by letting it impact on two PUR foam rings. These replaceable rings crush and absorb the energy of the piston. The explosions create a rather hostile environment, as Figures 4.2 and 4.3 show. This meant that much attention had to be given to protecting the transducers and their cables.

After the shot, the impulse plug is disassembled and rebuilt. A turn-around time of about 15 minutes was aimed for in the design. The piston is weighed before and after the shot, which gives the mass of the fragments. Finally, after a series of shots the recorded signals are processed and evaluated.

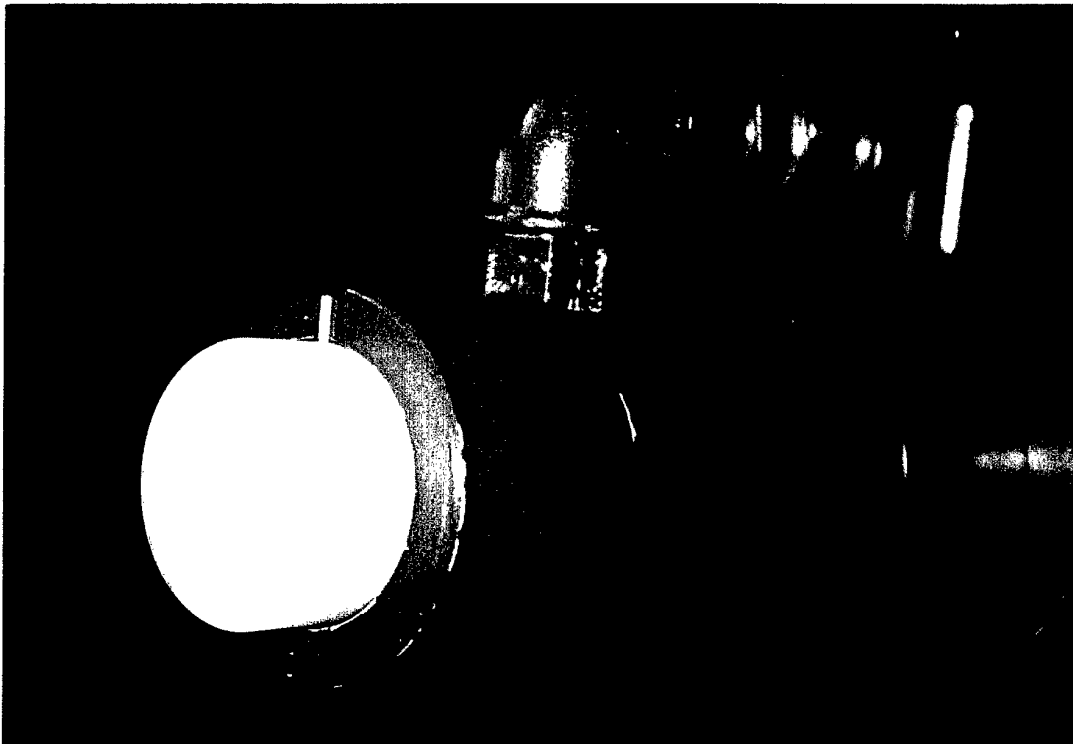


**Figure 3.1:** Drawing of the impulse plug. Parts:

- |                                     |   |
|-------------------------------------|---|
| 1 : replaceable nylon piston part   | 10 : end plate for foam   |
| 2 : cylinder                        | 11 : base   |
| 3 : ribbed steel piston part        | 12 : six bolts for assembly   |
| 4 : shock mount                     | 13 : mounting base  |
| 5 : piezoresistive accelerometer    | 14 : three bolts to mount nylon piston part                                       |
| 5a : bolt                           | 15 : fitting  |
| 6 : tube to protect cable           | 16 : eddy current displacement transducer, to detect passage of grooves on piston |
| 7 : foam to guide and protect cable | 17 : tube to protect cable.   |
| 8 : PUR buffer ring                 |   |
| 9 : PUR buffer ring                 |   |



*Figure 3.2: Piston of the impulse plug.  
From left to right: replaceable nylon piston part, ribbed steel piston part, tube to protect cable of accelerometer, cable and connector plug of accelerometer (980109-12).*



*Figure 3.3: Assembled impulse plug (980109-16).*

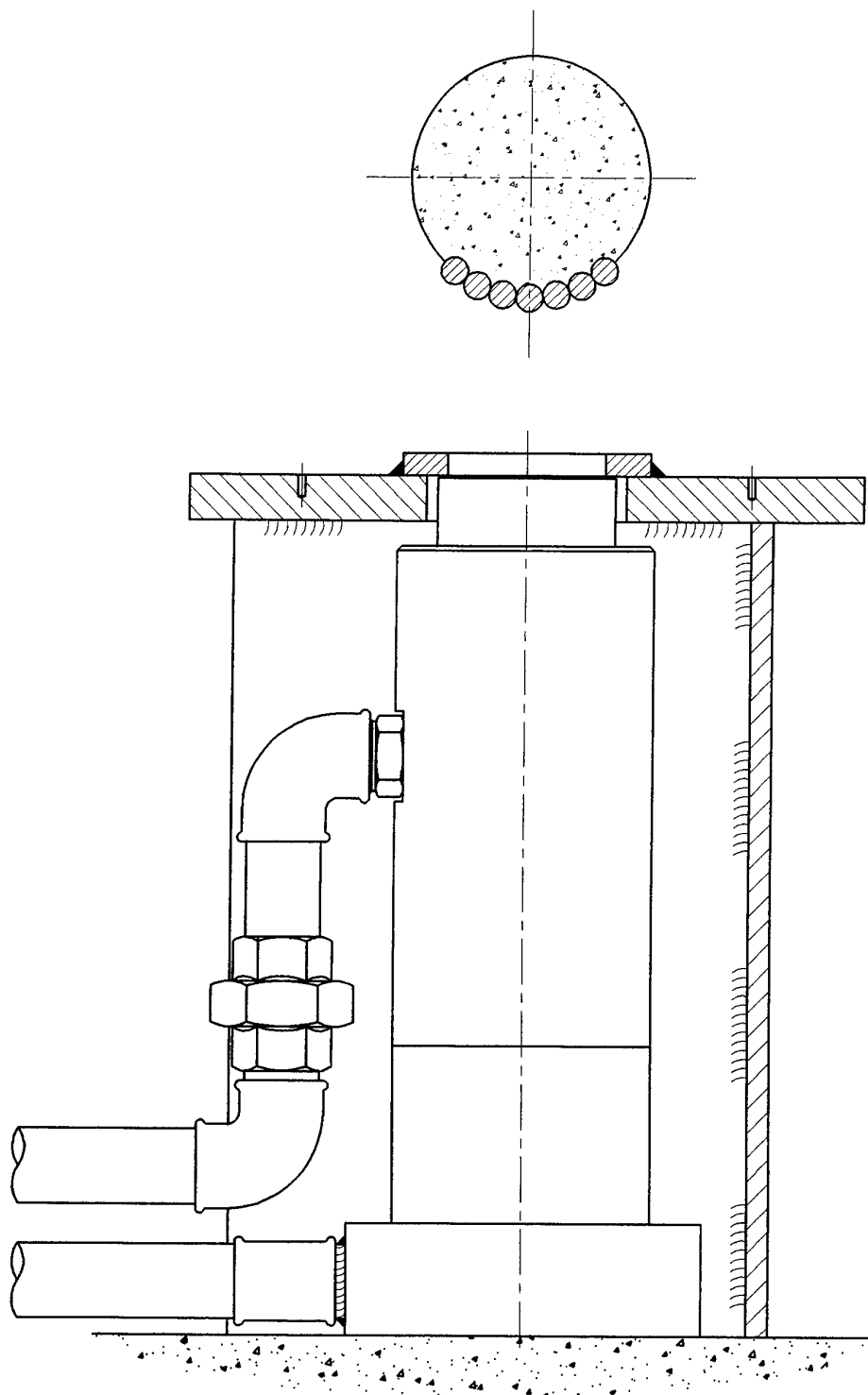


Figure 3.4: Experimental set-up.

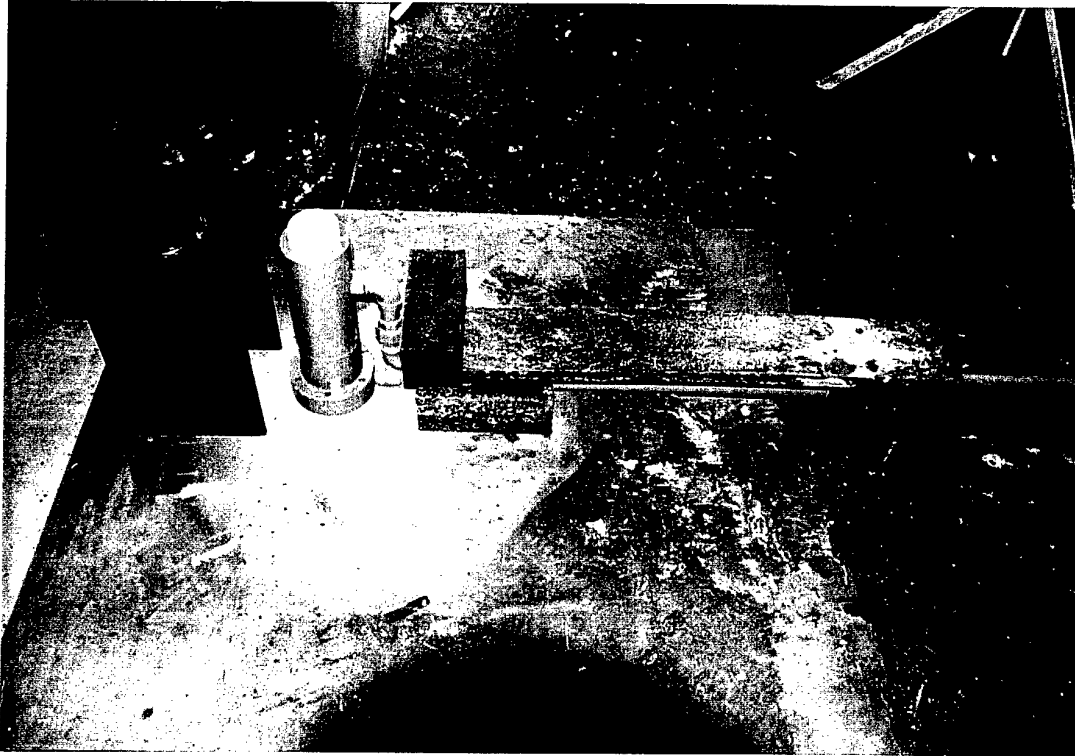
In this case, the impulse plug is placed vertically on the concrete floor of the bunker. The 'table' with the plate which smoothes the blast wave is placed over the impulse plug and the front face of the piston is brought level with the plate. Above the plug hangs a spherical explosive charge. Steel ball bearings are pressed into the plastic explosive to create fragments.

## 4 Testing of the prototype

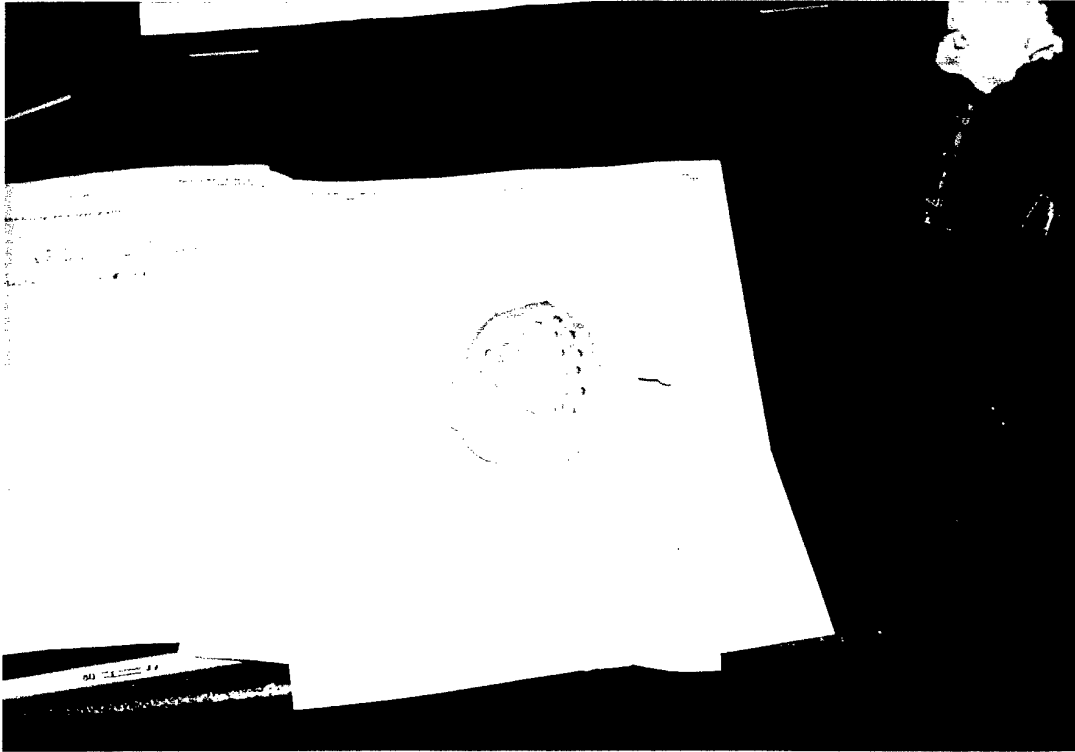
The prototype was tested to see how well it would perform. The accuracy of the measurements was tested by exposing the impulse plug to a known impulse from a blast or a projectile. At least as important as determining the accuracy was determining the best way to operate the instrument and finding out any deficiencies. One series of tests were done with high explosive charges, which were hung 20 cm above the impulse plug. Figure 4.1 shows the set-up. Two kinds of charges were used in these tests. The first were bare spherical charges, the second kind were the same charges, but with ball bearings pressed into the bottom side. Figure 4.2 shows such a fragmenting charge. Most charges had a mass of 200 gram. The blast from a bare charge is known from theory. Thus, the results of the measurements can be used to get an impression of the accuracy of the instrument. However, at close ranges, the theoretical predictions are not very accurate. This is due to turbulence in the fireball.

The measurement of the velocity of the impulse plug was done by two methods. The first method, with the accelerometer, did not produce satisfactory results. The signal showed oscillations with higher frequencies than expected. It also had an offset. As a result, it was impossible to derive a velocity from these signals. The accelerometer also proved cumbersome in use because great care was needed to ensure that its cable was not damaged during assembly and disassembly. Despite this care, the cable got stuck one time and the accelerometer was lost. The second method to measure the velocity, the time-of-flight measurement, was much more successful. The passage of the grooves could clearly be seen in these signals and the velocity could be established to within 10% accuracy. It is likely that using a different groove pattern can raise the accuracy further. In the first millisecond, the signal of the transducer was disturbed by the electromagnetic pulse that is generated by the explosion. This was not a problem in these experiments because the measurement time was long. It could become a problem in an experiment with shorter measurement times, that is, with a higher plug velocity. Some additional electric shielding will be required in that case.

The most important deficiency of the prototype was that the nylon part of the piston fractured. The material turned out to be brittle at these high strain rates. One consequence was that it broke free from the steel part, which makes it uncertain whether the entire piston had the same velocity. More importantly, the nylon piston cracked on fragment impact and got stuck in the cylinder. Thus, the velocities that were measured in the experiments with fragmenting charges are highly suspect. The main results of these experiments are listed in Table 1. The first experiments were done with bare charges. For those tests, the difference between the measured blast impulse and the theoretical impulse is given. It turned out that the measured impulse was considerably higher than the theoretical impulse. As said above, the piston got stuck in the experiments with a fragmenting charge. Deriving an average fragment velocity and average blast impulse for those experiments gave nonsensical values.



*Figure 4.1: Experimental set-up.  
The impulse plug is placed vertically on the concrete floor of the bunker. The 'table' with the plate which smooths the blast wave is standing left of the impulse plug. The tubing which carries the instrumentation cables away are extra protected by steel bricks and plates (980109-17).*



*Figure 4.2: Fragmenting charge.*

*The charge consists of 200 grams of plastic explosive with 7.5 mm diameter ball bearings pressed into the bottom. The rest of the explosive is left free to avoid unnecessary fragment damage to the bunker (980109-29).*

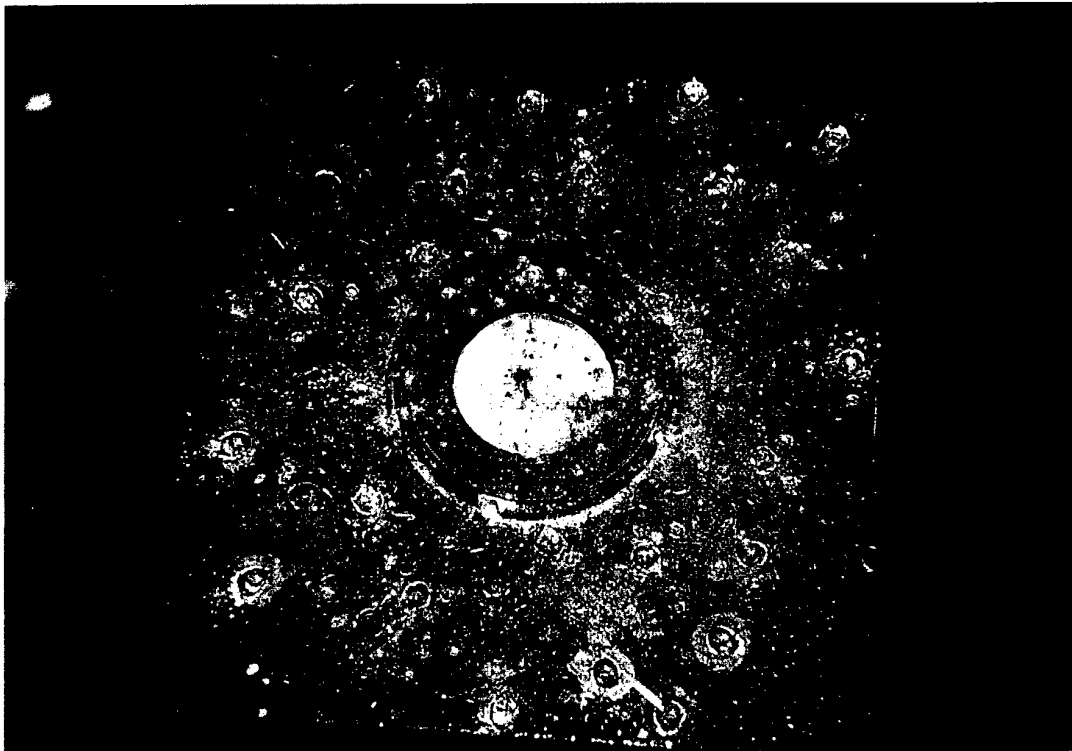


Figure 4.3: After the second fragmenting charge. This picture shows the effect of the fragments on the table and the nylon piston. The dents are caused by impacts of a single ball bearing (980109-34).

Table 1: Summary of results of experiments with charges.

Test i.d.	Mass of charge [g]	Diameter of fragments [mm]	Piston momen- tum [kg m/s]	Difference to theoretical blast [%]
imp020	200		12.03	78%
imp020-2	200		9.59	42%
imp021	600		38.62	121%
imp022	200	7.50	5.51	
imp023	200	7.50	7.50	

The testing with projectiles was done at TNO-PML's Laboratory for Ballistic Research. Fragment Simulating Projectiles (FSPs) were fired on the impulse plug, which was fitted horizontally. The velocity of the projectile was measured before impact, which together with the mass of the FSP gave the exact momentum. Again, the nylon part of the piston cracked and got stuck when the projectile penetrated. The Nylon part was reduced in diameter until it was able to move. It still generated some friction.

The measurement of the mass of the projectiles by weighing the piston before and after proved to be not accurate enough. The scales had an accuracy of about 1 g. On a projectile of 2 to 5 g, this gives a large measurement error. The solution is probably to use scales with a smaller measurement range and a piston with a lower mass.

The main results of these experiments are listed in Table 2. The momentum of the piston was always considerably lower than the momentum of the projectile. This is due to the friction of the cracked Nylon piston. Another factor was that the piston velocities were very low, which increases the effect of friction. The reason for the low velocities was that the impulse plug was designed for a fairly large load. Thus, the experiments were in the lowest part of its measurement range, which degraded the accuracy.

Table 2: *Summary of results of experiments with projectiles.*

Test i.d.	Mass of fragment [g]	Velocity of fragment [m/s]	Piston momentum [kg m/s]	Momentum difference [%]
imp005	2.85	721	1.47	-29%
imp006	2.85	806	1.16	-49%
imp009	2.85	720	0.99	-52%
imp010	5.3	667	2.41	-32%
imp011	5.3	666	1.85	-48%
imp012	5.3	661	2.12	-39%
imp013	5.3	672	1.20	-66%
imp014	5.3	668	1.01	-72%
imp015	5.3	673	1.13	-68%

## 5 Conclusions

The measurement principle that was best suited to measure the combined blast and fragment load from a close-in detonation is the impulse plug. To this concept a new idea was added which should allow the separation of the blast impulse from the fragment impulse. A prototype was designed, built and tested as a halfway step towards a practical instrument. In the prototype, two techniques to measure the plug's velocity were tried. The time-of-flight measurement was clearly superior. The main deficiency of the prototype was identified: the choice of material for the piston. The nylon that was used cracked when a fragment penetrated, causing the plug to get stuck. In addition, various other improvements to the design were identified. Apart from the nylon, the impulse plug proved to be a robust design and convenient to operate.

It can be concluded that the impulse plug is a good concept. It is probable that when the improvements are incorporated in the design, the instrument will perform well.

## 6 Recommendations

It is recommended to start the second phase of the study with the selection of the piston material. We suggest that the following improvements should be incorporated into the new design:

- design the new instrument for the loads used in the calibration experiments (and make the design easy to scale up);
- use only the time-of-flight measurement with the detection of the passage of grooves;
- adapt the grooves dimensions to improve accuracy of the time-of-flight measurement.

## 7 References

Literature on measurement techniques.

Drotleff, J. et al.,  
Research in Close-In Blast Loading from High Explosives,  
FMC Corp, ARL-CR-308, Santa Clara, CA, September 1996.

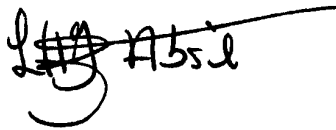
Held, M.,  
A simple technique of measuring the blast effect of realistic warheads,  
Proceedings MABS 12, Gramat, 1991.

Mehlin, H. and Parr, W.,  
Measurement of combined fragment-blast impulse in the near field of cased explosives,  
5th Engineering mechanics division speciality conference, pp. 640-643, 1983.

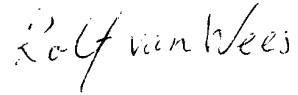
Morris, B.L.,  
Measurement of impulse from scaled buried explosives,  
Shock and Vibration Bull. no. 42, Pt. 2 pp. 123-127, 1972.

Weaver, G.W. and Walters, W.P.,  
Proximate blast loading of structures,  
10th Int. Symposium on Ballistics, 1982.

## 8 Authentication

A handwritten signature in black ink, appearing to read 'L.H.J. Absil'. The signature is stylized with a large, sweeping flourish at the end.

Dr. L.H.J. Absil  
Project leader

A handwritten signature in black ink, appearing to read 'R.M.M. van Wees'. The signature is written in a cursive style.

Ir. R.M.M. van Wees  
Author

---

## REPORT DOCUMENTATION PAGE (MOD-NL)

1. DEFENCE REPORT NO. (MOD-NL) TD98-0079	2. RECIPIENT'S ACCESSION NO.	3. PERFORMING ORGANIZATION REPORT NO. PML 1998-A39
4. PROJECT/TASK/WORK UNIT NO. 224698111	5. CONTRACT NO. B97D427	6. REPORT DATE November 1998
7. NUMBER OF PAGES 23 (excl. RDP & distribution list)	8. NUMBER OF REFERENCES 6	9. TYPE OF REPORT AND DATES COVERED Final
10. TITLE AND SUBTITLE Development of an instrument to measure the close-in impulse load of a fragmenting charge. Progress report 1. Design and testing of prototype		
11. AUTHOR(S) R.M.M. van Wees		
12. PERFORMING ORGANIZATION NAME(S) AND ADDRESS(ES) TNO Prins Maurits Laboratory, P.O. Box 45, 2280 AA Rijswijk, The Netherlands Lange Kleiweg 137, Rijswijk, The Netherlands		
13. SPONSORING AGENCY NAME(S) AND ADDRESS(ES) MOD-ML/DWOO P.O. Box 20701, 2500 ES, The Hague, The Netherlands		
14. SUPPLEMENTARY NOTES The classification designation Ongerubriceerd is equivalent to Unclassified.		
15. ABSTRACT (MAXIMUM 200 WORDS (1044 BYTE))  This progress report describes the development and testing of an impulse plug. Anticipated applications are, for example, the measurement of the impulse load of an AP mine on a vehicle belly. The tests identified improvements that will have to be incorporated into the final design.		
16. DESCRIPTORS <div style="text-align: right; margin-right: 50px;">DESCRIPTORS</div> Charge measuring instruments Detonation Explosion effects Loading Measuring instruments Prototypes		
17a. SECURITY CLASSIFICATION (OF REPORT) Ongerubriceerd	17b. SECURITY CLASSIFICATION (OF PAGE) Ongerubriceerd	17c. SECURITY CLASSIFICATION (OF ABSTRACT) Ongerubriceerd
18. DISTRIBUTION AVAILABILITY STATEMENT  Unlimited Distribution	17d. SECURITY CLASSIFICATION (OF TITLES) Ongerubriceerd	

Distributielijst \*

- 1 DWOO
- 2\* HWO-KL
- 3\* HWO-KLu
- 4\* HWO-KM
- 5 HWO-CO
- 6 DGW&T/CD/TB  
Ir. D. Boon
- 7 DM&P TNO-DO
- 8\* DM&P TNO-DO, accountcoördinator CO
- 9\* TNO-FEL, Bibliotheek
- 10/12 Bibliotheek KMA
- 13\* Lid Instituuts Advies Raad PML  
Prof. B. Scarlett, M.Sc.
- 14\* Lid Instituuts Advies Raad PML  
Prof. ir. K.F. Wakker
- 15\* Lid Instituuts Advies Raad PML  
BGen. Prof. J.M.J. Bosch
- 16\* Lid Instituuts Advies Raad PML  
Ir. A.H.P.M. Schaeken
- 17 TNO-PML, Directie; daarna reserve
- 18 TNO-PML, Hoofd Divisie Munitietechnologie en Explosieveiligheid  
Ir. P.A.O.G. Korting
- 19/21 TNO-PML, Divisie Munitietechnologie en Explosieveiligheid,  
Groep Explosiepreventie en Bescherming  
Dr. ir. G.H. Weerheijm, Dr. ir. L.H.J. Absil en Ir. R.M.M. van Wees
- 22 TNO-PML, Divisie Munitietechnologie en Explosieveiligheid,  
Groep Explosiepreventie en Bescherming, Reserve
- 23 TNO-PML, Documentatie
- 24 TNO-PML, Archief

---

\* De met een asterisk (\*) gemerkte instanties/personen ontvangen uitsluitend de titelpagina, het managementuittreksel, de documentatiepagina en de distributielijst van het rapport.