

• *The Royal Aeronautical Society* •

The one multidisciplinary professional institution dedicated to the global aerospace community

Third Test and Evaluation International Aerospace Forum

• *Management and Technology Trends
in Engines and Aircraft into the 21st Century*

PROCEEDINGS

19990115 059

23-25 June
London



REPORT DOCUMENTATION PAGE

Form Approved OMB No. 0704-0188

Public reporting burden for this collection of information is estimated to average 1 hour per response, including the time for reviewing instructions, searching existing data sources, gathering and maintaining the data needed, and completing and reviewing the collection of information. Send comments regarding this burden estimate or any other aspect of this collection of information, including suggestions for reducing this burden to Washington Headquarters Services, Directorate for Information Operations and Reports, 1215 Jefferson Davis Highway, Suite 1204, Arlington, VA 22202-4302, and to the Office of Management and Budget, Paperwork Reduction Project (0704-0188), Washington, DC 20503.

1. AGENCY USE ONLY (Leave blank)		2. REPORT DATE 24 June 1998	3. REPORT TYPE AND DATES COVERED Conference Proceedings	
4. TITLE AND SUBTITLE Third Test and Evaluation International Aerospace Forum			5. FUNDING NUMBERS F6170898W0012	
6. AUTHOR(S) Conference Committee				
7. PERFORMING ORGANIZATION NAME(S) AND ADDRESS(ES) Royal Aeronautical Society 4 Hamilton Place London W1V 0BQ United Kingdom			8. PERFORMING ORGANIZATION REPORT NUMBER N/A	
9. SPONSORING/MONITORING AGENCY NAME(S) AND ADDRESS(ES) EOARD PSC 802 BOX 14 FPO 09499-0200			10. SPONSORING/MONITORING AGENCY REPORT NUMBER CSP 98-1013	
11. SUPPLEMENTARY NOTES				
12a. DISTRIBUTION/AVAILABILITY STATEMENT Approved for public release; distribution is unlimited.			12b. DISTRIBUTION CODE A	
13. ABSTRACT (Maximum 200 words) The Final Proceedings for Third Test and Evaluation International Aerospace Forum, 23 June 1998 - 25 June 1998 What do we need to test, and what facilities do we have? Management changes of test facilities; Technical changes of test facilities; Future test technology needs; Test technology solutions for the 21st Century.				
14. SUBJECT TERMS EOARD, Test & Evaluation			15. NUMBER OF PAGES	
			16. PRICE CODE N/A	
17. SECURITY CLASSIFICATION OF REPORT UNCLASSIFIED	18. SECURITY CLASSIFICATION OF THIS PAGE UNCLASSIFIED	19. SECURITY CLASSIFICATION OF ABSTRACT UNCLASSIFIED	20. LIMITATION OF ABSTRACT UL	

NSN 7540-01-280-5500

Standard Form 298 (Rev. 2-89)
Prescribed by ANSI Std. Z39-18
298-102

Third Test and Evaluation International Aerospace Forum

The Management and Technology Trends
of Ranges and Facilities into the 21st
Century

PROCEEDINGS

The Royal Aeronautical Society does not accept responsibility for the technical accuracy nor for the opinions expressed within this publication.

Published by
The Royal Aeronautical Society, 4 Hamilton Place, London, W1V 0BQ
Tel: +44 (0)171 499 3515 Fax: +44 (0)171 493 1438 (Conference Department only)
Email: raes@raes.org.uk WWW: <http://www.raes.org.uk>

© The Royal Aeronautical Society

ISBN 1 85768 054 5

AQF99-04-0635

CONTENTS

PAGES

Looking at T&E Over the Horizon – Can We Sustain the Vision? Dr P A Sanders, Mr J Gehrig and Mr G Harris, Department of Defense, USA	<i>Not available for publication</i>
The Twisted Chain AVM S M Nicholl, Ministry of Defence, UK	<i>Not available for publication</i>
Status of US Test Resources Hon J E Krings, Krings Corporation, USA	<i>Not available for publication</i>
Test and Evaluation in the New Millennium – A European Industrial Perspective Mr R N Lee, British Aerospace Military Aircraft & Aerostructures, UK	4.1 - 4.7
Integration and Operation of T&E Ranges in a Trading Environment Dr C Rigden, Defence Evaluation and Research Agency, UK	5.1 - 5.8
Selling Change in the "New" Boeing Company: Integrating 600 Laboratories Mr W E Newman and Mr R J Jablonski, Boeing Information, Space & Defense Systems Group, USA	6.1 - 6.5
The Development of German Military Aerospace Testing – Managing the Last 50 Years Dr -Ing H Tönkötter and Mr M Braitering, IABG, Germany	<i>Not available for publication</i>
Test Range – A Profit Center? The Israeli Experience Mr A Leshem, Weapon Test and Evaluation Center, RAFAEL, Israel	8.1 - 8.5
Distributed Simulation and Test and Evaluation: A Midterm Report on the Utility of Advanced Distributed Simulation to Test and Evaluation Col M E Smith, Joint Advanced Distributed Simulation Joint Test Force, US Air Force and Dr L McKee, SAIC, USA	9.1 - 9.12
British and United States Participation in a Demonstration of GPS Range Instrumentation Mr W Ellis, RAJPO, Mr N Raimondo, TASC, USA and Mr P Travis, British Aerospace Defence Ltd, UK	10.1 - 10.5

<p>The Evolution of Optical Tracking Facilities Within UK Test and Evaluation Ranges Mr J Lees, Defence Evaluation and Research Agency, UK</p>	<p>11.1 - 11.9</p>
<p>Validation of Future Gas Turbine Technology by BR700 Core Demonstrator Engine Tests in the Stuttgart University Altitude Test Facility Dr M Menrath, Dr K J Schmidt, Mr R Merten, BMW Rolls-Royce Aero Engines and Prof W Braig, University of Stuttgart, Germany</p>	<p>12.1 - 12.14</p>
<p>Planning for the Future of the Test and Evaluation Infrastructure Mr W B Milway, Mr N Toomer and Mr R W Pace, Department of Defense, USA</p>	<p><i>Not available for publication</i></p>
<p>Test Technology Needs Identification for the 21st Century United States Air Force Mr C D Tompkins, Air Force Flight Test Center, Mr D Hite, Space and Missile Systems Center, Mr T Best, Arnold Engineering Development Center and Ms C Schurr, Air Force Development Test Center, USA</p>	<p>14.1 - 14.12</p>
<p>The Use of Modeling and Simulation in the Operational Test of Military Aircraft: Promises and Challenges Dr D Wiesenbahn and Mr R Dighton, Institute for Defense Analyses, USA</p>	<p>15.1 - 15.9</p>
<p>The Role of Test and Evaluation in Early 21st Century Systems Engineering Prof P H Sydenham, Defence Engineering Group Systems Engineering Team, University College London, UK and Australian Centre for Test and Evaluation, Australia and Mr D Kimberley, Defence Engineering Group Systems Engineering Team, University College London, UK</p>	<p>16.1 - 16.6</p>
<p>Testing the Virtual Aeroplane Mr A N Grazebrook, i-Logix UK Ltd, UK</p>	<p><i>Paper withdrawn</i></p>
<p>A Future Instrumentation Concept, Suitable for Test and Training Mr M L Burski, Institute for Defense Analyses, USA</p>	<p>18.1 - 18.5</p>
<p>Will Facilities be Required? Virtual Testing Shapes Future of Test Facility Requirements Mr R G Pollard and Mr T E Stevenson, US Army Test and Evaluation Command, USA</p>	<p>19.1 - 19.8</p>
<p>Changing Requirements for Aerial Targets Mr J K Buck and Dr J N Towing, Defence Evaluation and Research Agency, UK</p>	<p>20.1 - 20.7</p>

Test and Evaluation in the New Millennium
– A European Industrial Perspective
Mr R N Lee, British Aerospace Military Aircraft &
Aerostructures, UK

Test and Evaluation in the New Millennium
A European Industrial Perspective

R. N. Lee MBE CEng FRAeS
Director of Test Engineering
British Aerospace Military Aircraft & Aerostructures

Abstract

The paper initially reviews the factors which have influenced the business since the 1950's and investigates the trends which have driven policy. It discusses the moves towards a smaller UK Industry with the advent of the growing affordability issue and some of the measures adopted in response.

The review continues with an assessment of the current international scene and the impact that this is perceived to have on European Programmes and their associated Test and Evaluation. From this base, consideration is given to the future needs of testing within Europe, both in terms of test technology and test infrastructure. A number of issues are raised with regard to national facilities, their affordability and capability.

The paper concludes with an assessment of these issues and proposes a number of challenges which need to be addressed to satisfy European Industry needs.

The Historical Perspective

After World War Two the major Test and Evaluation Facilities in Europe were Government owned and managed. Military aircraft and weapon programmes were similarly entirely Government funded and centrally managed under cost plus contracts.

The relatively low cost of programmes permitted countries to pursue a wide range of projects simultaneously and several entirely new projects could be started in a single year. In the second half of the 1950's the UK Government was funding and managing the simultaneous development and production of a wide range of aircraft programmes, including fighter aircraft, for the Royal Air Force and Royal Navy (Hunter, Swift, Javelin, Sea Vixen, Scimitar) at the same time as developing the 3 V bombers and several training, transport and general purpose aircraft. A similar situation existed in the helicopter and missile side of the industry. This allowed a large number of relatively small companies to survive and indeed flourish, the cost plus environment gave little incentive for the companies to change or invest in their futures. Technology was paramount - the threat was the USSR - cost did not seem to be a major issue.

During the 1960's the situation began to change as the cost of the technology required to achieve combat advantage escalated. By the middle of that decade this had forced company mergers and factory closures in the UK and the start of European collaborative projects such as the Anglo-French Jaguar, the Franco-German Alpha Jet and the Tri-national Tornado.

Notwithstanding this, European Test Facilities, continued to be numerous, Government owned and available as "free issue" to Contractors. Management of these Facilities in the UK was the responsibility of a number of Government Departments with little apparent overall coordination or strategy. There was much duplication of facilities across Europe, each country tending to own a total National capability which might vary from Benchmark in some facilities to average or low in others.

By the end of the seventies, international collaboration had become the norm for European Industry. Few major single nation projects were being started. Emphasis was on establishing common military requirements and, through military and industrial collaboration, common solutions.

Industrial downsizing and mergers continued in the UK such that there remained effectively only one fixed winged company, one helicopter manufacturer and one engine company.

In the early 1980's, and in response to the trend of large cost and timescale overruns on many projects, the UK Ministry of Defence procurement policy changed from "cost plus" to "fixed price". Major new projects from the late 1980's e.g. Eurofighter, Merlin, Apache and Nimrod 2000 as well as updates to in-service aircraft were contracted on this basis. Furthermore MOD moved towards "off the shelf" procurement whenever possible and employed international competitive tendering for many of the new requirements.

These changes resulted in the transfer of the risk in these programmes from the MOD to the Contractor, requiring the Contractor to manage the programme and be responsible for all dependencies. Consequently, the approach to Test and Evaluation changed with the Contractor taking full responsibility for the overall development programme. Against this increasingly commercial backdrop, the use of test methods and facilities which provided the most effective and timely solution to the test requirements became paramount.

The fall of the Berlin Wall and the collapse of the former Soviet Union heralded the era of the so called "Peace Dividend" which resulted in national defence budgets falling almost universally. As well as cuts in its defence procurement programmes, the UK Government responded with moves to reorganise the Test Establishments and to change funding policies to apply more commercial management to their operations. Organisationally, Government Test Facilities were brought together under the Defence Evaluation and Research Agency (DERA). Consequently DERA now has an integrated capability which controls all the Government defence facilities for testing of air, sea and land systems. Clearly there are now many facilities under the DERA umbrella and, whilst inappropriate to list them all, it is considered worthwhile to mention some of those within the Air Sector, with which I am most familiar, and which are also particularly important to UK Industry.

There are several major instrumented weapon ranges at Aberporth, West Freugh and Benbecula and the airfields at Llanbedr as well as Boscombe Down, which houses the Official Test Centre, ETPS and facilities such as the Environmental Test House and the Radio Environment Generator. These, together with the Wind Tunnels and Flight Simulators at Bedford and Farnborough, constitute a comprehensive set of Air Sector facilities. This reorganisation has opened the way, I believe, for close collaboration between Government and Industry in the provision of test facilities for all sectors of Defence.

Although some of the above facilities continue to be provided free of charge to the Contractors under fixed price terms, MOD contracts now generally expect the Contractor to provide and cost for all required facilities so that the Government is not held responsible for these dependencies. This in itself has ensured that Contractors seek the most cost effective solution to each requirement. This may result in overseas facilities being used if appropriate for example, Eglin AFB in Florida USA is being used for the Matra BAe ASRAAM trials and OTB Overberg in South Africa was used recently for Hawk aircraft weapon release trials. Development of the Contractors' own facilities is an option where this is cost effective in the longer term and joint developments with Government are also possible. The Electronic Warfare Test Facility (EWTF) completed at Warton in 1997, is one such new National facility funded equally by Government and BAe MA&A and available for both Industry and Government Agency use.

The North Sea Air Combat Manoeuvring Instrumentation (ACMI) Range is an example of Industrial investment in a Training and Test Facility. Owned and operated by British Aerospace, but located at RAF Bases at Waddington and Coningsby, it offers realistic air combat training with sophisticated post flight analysis. Eight European Air Forces and the USAFE have signed contracts and are regularly using the facility which is the only Industry owned and managed ACMI Range in the world. It offers cost effective training on a pay by hour basis without the overhead cost of ownership. Both DERA Boscombe Down and BAe MA&A have used the facility for a small number of aircraft/weapon system development flights and continued small scale use is anticipated on future programmes. Overall, this type of Industrial investment, providing a European capability, might prove to be a model for some future Test and Evaluation facilities.

Moving on now to partnerships in the Test Programmes themselves, Development Programmes such as Eurofighter, Tornado GR4 and Nimrod 2000 now include Official Test Centre (OTC) Pilots and Engineers in the Contractors fixed price development contracts. These Teams from DERA Boscombe Down form an integral part of the Company's Test Organisation, carry out systems rig and aircraft trials and fly a proportion of test sorties. They contribute to test definition and the analysis of data and have access to all test results as they are generated. This new approach allows the OTC to obtain much earlier, detailed and continuous experience of the aircraft and to formulate their service clearance

recommendations progressively, without the need for additional flights and disruption of the development programme, by transferring test aircraft from the Contractors site to the OTC airfield.

As the next natural step, we are now drawing the Customer's Operational Team into the Development Programme. Nimrod 2000 will be the first to do this and a Joint Trials Team will be established under Contractor management, which combines the talents of British Aerospace, the Official Test Centre and the Royal Air Force Operators to ensure the aircraft not only satisfies specification, but is user proven when it enters Service.

This teaming in Contractor Led Trials is complemented by the introduction of process changes which also allow more effective testing to be performed. Flight Test Real Time Analysis (RTA) has been introduced by BAe MA&A. This allows data transmitted from the test aircraft, via a telemetry link, to be processed and compared in quasi real time with outputs from aircraft models which are being run in parallel on the ground using the same initial flight conditions as the test aircraft. Using this technique accelerated aerodynamic clearance has been achieved on the Eurofighter programme and is planned for the Nimrod 2000. This methodology is now being expanded to cover weapon systems trials by comparing telemetred sensor and weapons system data with data generated from sub system models driven by reference data received in real time from the test range. Further enhancements are being developed through the use of IN/GPS pods and differential correction techniques to

allow weapon system development trials to be conducted off Range. This aspect is dealt with in more detail in the paper being presented at this Forum in Session III. (Reference 1).

Across Europe, and somewhat modestly, the wider process of rationalisation of the European Defence Industry has begun. The Governments of Germany, France and the UK have made coordinated statements of intent and the Industrial Contractors have responded separately with their proposals. Already some Industrial Joint Ventures such as Matra BAe Dynamics have been established and at the beginning of May we had the announcement that SAAB and BAe would consolidate by BAe acquiring a 35% stake in the SAAB Aircraft and missile business. We now await eagerly for more and larger groupings to be announced, moving towards the ultimate goal of a single European Defence consortium.

Within the UK a number of initiatives have begun to assess the Nation's future Test and Evaluation needs against this background of rationalisation. One such is the Joint Ministry Industry Facilities Forum (MIFF) which has members from DERA, the Society of British Aerospace Companies (SBAC) and the Defence Manufacturers Association (DMA). This is currently reviewing capabilities and needs across a wide range of Defence Programmes (Land, Sea and Air) with the aim of identifying areas where joint action (rationalisation, harmonisation and co-development) will benefit the UK's National T&E Capability.

A similar European approach is necessary and some degree of collaboration across Europe has also commenced. Joint Government funding (UK, France, Germany and Holland) produced the European Transonic Wind Tunnel in Cologne. This world class facility, capable of full scale Reynolds number testing, has been operational for 3 years. Some National Wind Tunnels have been brought together and managed as European capability under the Joint German/Dutch Agency DNW. However, unless accompanied by the wider rationalisation of the European capability, these initial moves face potential commercial failure rather than success.

There remain a large number of other National facilities including Test Ranges and Test Houses in Europe, both Government and Industry owned. Some would be judged to be excellent, but others may be at best average. Rationalisation of these to achieve the required capacity which matches the Defence workload, developing those that are to be maintained, and closing or cocooning those that are surplus, must be a priority. Attention must be paid also to the way we manage and charge for the use of the Facilities - we must establish equitable charging rates and procedures for allocating test time to all customers.

Into the 21st Century

European defence requirements into the next century will continue the existing trends of regular updates to in-Service equipments to prolong their service lives, including operational role changes and regular updates to preserve operational

effectiveness. New projects will, I believe, focus on stealthy platforms capable of long range engagements, utilising smart technology, stand off weapons and other unmanned vehicles. This will result in the continuing requirement for the current Test Ranges and Facilities, however, the total volume of testing will tend to reduce following process improvements and flat or even further reduced National Defence budgets.

The ongoing changes to design processes, which utilise complex integrated modelling techniques, lend themselves to "virtual testing" during the design phases. These quite radical process improvements will change our approach to actual testing and will reduce the number of physical tests required. This process has already started in the aerodynamics discipline where high fidelity stability and control, structural loads and structural dynamics models are being used in the flight test phases of the most advanced projects with significant reduction in the amount of flight testing required.

We can anticipate that the development of Computational Fluid Dynamics (CFD) will result, in time, in the reduction in the need for Wind Tunnel testing. It will also further improve the effectiveness of aerodynamic modelling in general and this will also feed through into reduced flight testing.

The ability to be able to achieve the objectives of traditional between-flight analysis in quasi real time has allowed the flying programmes to be carried out in a shorter timescale and resultant lower costs. Currently, and as discussed earlier, these techniques are being extended to cover all

the aircraft flight and weapon systems and we can confidently predict the same level of savings will be achieved across the full range of flight testing. The provision of "real time" data from Instrumentated Ranges and the use of IN/GPS Pods will further increase the rate at which flight testing can be achieved and has the potential to reduce development programme timescales and hence cost.

Returning to Facilities themselves, I believe that it is possible to identify a number of Test Facility shortfalls in the UK that will need to be addressed over the next few years either by developing new or existing facilities or deciding to purchase the capability overseas. Decisions of this nature need to be taken in full consultation with the relevant Government Agencies and Industrial organisations if unnecessary expenditure or duplication is to be avoided. Specific capabilities to be considered include the following:-

- ◆ Stealth Measurement Facilities.
 - Ground Radar Cross Section (RCS) measurements of large models and full scale vehicles.
 - Ground to Air RCS measurements of air vehicles at all aspects and including assessment of counter measures.
 - Air to Air Infra-red (IR) measurements to establish signature versus aspect and effects of countermeasures and decoys.

- ◆ Overland Range for testing standoff weapons and unmanned vehicles.
- ◆ Land and Sea Ranges where lasers can be accommodated without undue restrictions.
- ◆ Unmanned flying targets with realistic performance.
- ◆ Secure data links from Ranges and other major Test Facilities to allow test data transmission to customers in real or quasi real time.

Discussions are taking place between DERA, MOD and Industry on some of the above in the relevant discipline groups, and as mentioned earlier, the recently formed MIFF has started reviewing UK capabilities and requirements. These initiatives need to be consolidated within an overall framework to establish the necessary strategies and plans to address all future requirements. Partnership between Government and Industry is key to a successful outcome. I believe it is necessary to achieve a common understanding of UK requirements and capability before we engage in the wider debate within Europe as a whole.

In conclusion, I would like to state that the discussion of the reality of our current Test Facility base requires an inspired look into the future, which is in itself very risky! The future has a consistent habit of surprising us and, although we sometimes predict the direction of change correctly, we nearly always get the timescale wrong!

Nevertheless, I would like to leave you with the following conclusions which I believe are the important challenges for the future:-

- Avoid duplication and wasted effort by ensuring that Government Agencies and Industry work together in close partnership, to develop and manage the Test Facilities necessary to support our Defence programmes.

- Ensure that the new integrated approach to development testing, described as "Contractor Led Trials" and introduced on Eurofighter and Nimrod 2000 is adopted as best practice for Future Projects and to extend this partnership to include the Operational Evaluation Units (OEU's).

- Continue to develop the concept of Real Time Analysis and to extend it to all major Test Facilities.

- Ensure that all Test and Evaluation areas are closely involved with the ongoing changes in design processes and the development of "Virtual Testing". The opportunities that these developments offer to reduce the final development and certification phases must not be wasted.

- Ensure that, as the European Defence Industries continue the process of integration, the Test and Evaluation community take advantage of the opportunities for sharing best practice in techniques and methods, establishing centres of excellence and rationalisation of Facilities.

References

Ref. 1- Page no.4

W. Ellis/N. Raimondo/P. Travis.

"British and United States Participation in a Demonstration of GPS Range Instrumentation".

**Integration and Operation of T&E Ranges
in a Trading Environment**
Dr C Rigden, Defence Evaluation and Research Agency,
UK

INTEGRATION AND OPERATION OF T&E RANGES IN A TRADING ENVIRONMENT

Dr Chris Rigden

Defence Evaluation and Research Establishment (DERA)

Boscombe Down, Salisbury, England

Abstract

This paper describes changes that are being made to adapt the UK Ministry of Defence Test and Evaluation (T&E) Ranges, so that they meet the challenges of the future.

These changes are being made to the way in which the ranges are managed, operated and funded, and a case history is presented to illustrate the potential benefits of the changes.

A clear lesson to emerge is that partnerships with customers and between National and International suppliers of T&E range services are necessary to ensure we get the best value for money from our expensive ranges and facilities.

Introduction

The only certainty about the future is that everything will continue to change, and that the pace of change is accelerating. These changes are likely to involve:-

- the threat;
- the nature of conflict;
- technologies;
- computer based modelling and simulation;
- budget priority;
- procurement processes;
- multi-national programmes;
- globalisation.

At the moment we can only dream about the directions in which some of these changes are going to take T&E over the next few years, and yet we have to prepare for the future.

As we all know, the process of change is often painful and it is sometimes difficult to be confident that we are doing the right thing. I believe it can benefit us all to share the lessons we are learning as we each undertake our various changes. Perhaps, this paper may help some of you who are facing the same issues as we are in the UK T&E ranges, and conversely, if any one feels we are doing it wrong then you will tell us - sooner rather than later would be appreciated!

DERA T&E Ranges

The UK has many T&E ranges, generally situated in out-of-the-way places for safety and security reasons, but as a consequence also in some of the most beautiful areas of the country.

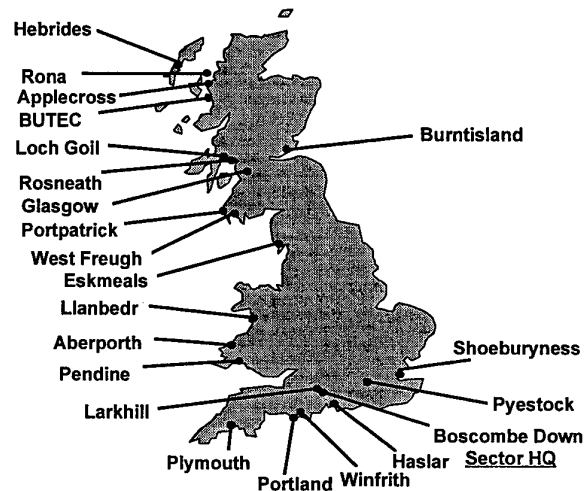

DERA T&E ranges

These ranges provide safe and secure spaces and facilities for inherently dangerous tests, experiments, trials and exercises in all three environments - land, sea and air.

Land ranges are used for work spanning research and development through to in-service proof of artillery systems and small and medium calibre weapons, including environmental testing and disposal of munitions, and for static and dynamic work requiring large danger areas;

Sea ranges are used primarily for measurements of acoustic signatures, magnetic signatures and for underwater tracking and system calibration work;

Air ranges are used for test and training firings of all variants of guided and unguided missiles, UMA and air delivery systems.

Until 1995 the UK ranges were treated as relatively autonomous establishments, although many were collectively grouped in an organisation called DGTE (Director General Test and Evaluation) by this time.

In 1995 DGTE joined forces with 3 other parts of the UK MoD to form the Government owned Defence Evaluation and Research Agency, DERA. Within DERA all the T&E ranges have now been grouped into a single sector which has a turnover of about £120m per year.

Funding arrangements

When the ranges joined DERA in 1995 they were transferred from vote fund to a trading fund accounting system.

I believe that this change will prove to be the single most important event that will stimulate and allow facility-rich organisations such as the T&E ranges, to adapt to the rapidly changing world.

Under the vote system, Parliament through the Treasury allocates money to MoD each year, and this allocation is further sub-allocated by MoD HQ to different departments and so on down the management chain.

Prior to 1995, each of the functions on the T&E ranges received their share of this allocation to fund their activities.

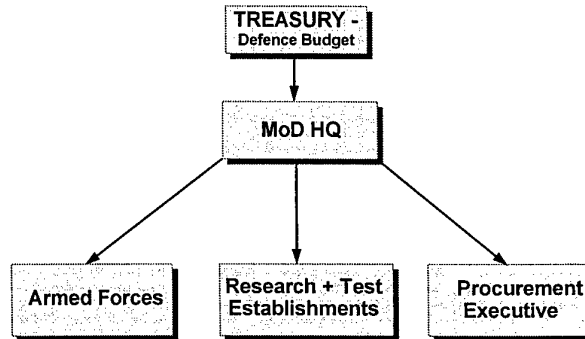

Pre-Agency funding arrangements

Under vote funding, the ranges developed some very distinct organisational features such as:-

- a hierarchical management structure with loyalty and responsiveness up the management chain of command (because that is where the money comes from);
- departmentalised or “stove piped” functions, with each department having its own priorities. To get a job done that required several departments was difficult to co-ordinate, since departments only came under a common manager somewhere high in the MoD HQ organisation;
- a static organisation, since the vote in any one year was generally much the same as for the previous year, and there were relatively long lead times for major changes. This made the organisation slow to respond to change;
- long lead times in getting major new investment to keep facilities up to date;
- each site being self-sufficient to cope with peak loads, leading to duplication of capability and excess capacity across the ranges.

In 1995 this situation changed, and many MoD facilities, including the ranges, joined DERA under a trading fund arrangement as illustrated in the next figure.

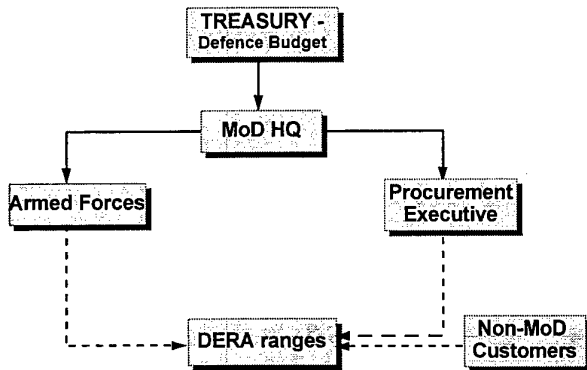

DERA funding arrangements

Money is no longer allocated each year to the ranges, but the ranges share of the vote is given to the users or ‘customers’ of the ranges.

Consequently, the ranges now only get money to sustain their operation when they carry out tasks that customers request. The trading fund requires us to recover all costs of operation plus a small return to Treasury (but I hasten to add we are not a profit making organisation).

Also, because the customers now have the money, they are no longer bound to use the T&E ranges.

This, as all of you from industry have known for a long time, concentrates the mind on understanding customer requirements and customer service - especially when, as in the case of ranges, the customers think the service is much too expensive now they have to pay for it rather than get it for free.

An immediate reaction to this situation was to question whether the ranges could survive. Now it is said that a crisis is needed to motive change and in a way a crisis has been created.

In the case of T&E ranges it has induced us actively to seek and implement innovative

ways for managing and operating our (expensive) facilities, as outlined below.

The management of UK T&E ranges since 1995

In making the transition to a trading fund it quickly became apparent that the “stove pipe” type management was very inappropriate. The organisational responsiveness had to be re-focused to where the money now comes from - i.e the customer. To achieve this within the ranges sector we have adopted the DERA project management based approach to react to and solve customer needs and problems.

For each customer requirement, we set up a project to interpret the customer’s needs, to develop solutions to meet that need, and to marshal and manage all the resources needed to deliver what the customer wants. This means drawing on the pool of Human Resources to build the necessary multi-functional teams to undertake the T&E work, and the facilities needed for the particular job in hand. When we have delivered our service or T&E results to our customers’ satisfaction, we then get paid for the job.

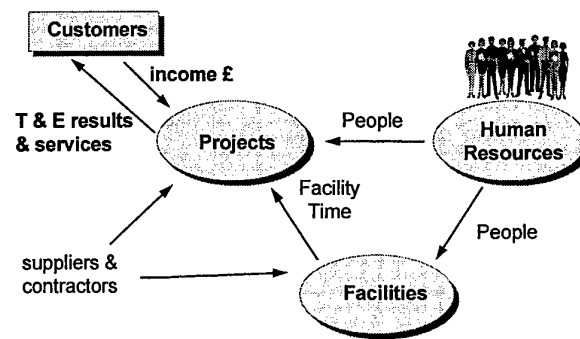

Customer focused organisation

The immediate advantages of the new arrangements are:-

- greater responsiveness to customer needs;
- easier investment processes to enhance facilities by borrowing from the trading

fund (assuming a good business case is made) since costs of the investment can be recovered steadily from customer over a number of years rather than in one large payment;

- areas or resources not in demand or used to solve customer requirements are quickly identified because they do not recover their costs, and necessary action can be put in place to correct for this.

This final point was at first thought to be a major stumbling block, when the implications of the trading fund arrangement became apparent. With the loss of stability of the vote funding, the question was asked how could facilities be sustained when the demand (and hence volume of work) for them varies considerably - perhaps over a several year cycle? How can facilities recover their costs in the lean times?

For ranges the solution lies in not treating each facility or site as an individual self contained entity, but applying the new management model across all ranges. For example:-

- the staff management is networked across the ranges so that people from one range having a quiet time can help out at ranges which are busy - thus avoiding each range catering for peak loads individually. This implies much more multi-skilling of staff (to turn their hands to many different tasks) and greater flexibility of deployment, which in turn requires training investment and better rewards for people;
- sharing of facilities across ranges, especially perhaps mobile instrumentation, which helps remove duplication of capability and ensures higher utilisation of assets;
- not tying project management to a given range but encouraging project managers to look across all ranges for the best solutions to customer problems.

All these measures can help reduce the costs of operating facilities and offer better value for money.

In the new management structure we now have to set a rate for the job so that the payments we receive cover not only the workers undertaking the T&E, but also cover associated central management costs and all infra-structure costs. For ranges sector these costs represent 5% and 46% of total costs respectively.

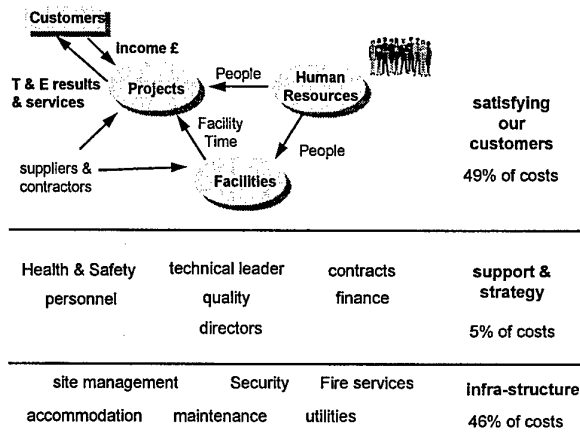

Full costs of service

The role of central management is no longer one of control, but is much more concerned with support and setting the strategy for the future - it is all about creating an environment conducive to effective and efficient range T&E work.

The infra-structure costs - the security, health and safety, accommodation, utilities, site costs and liabilities - are traditionally regarded as fixed costs; they are incurred whether or not we carry out any customer work using the facilities.

So really, it could be argued that we can only affect 49% of the costs (ie doing the customer's work) by the new flexible management arrangements.

But this is not so, and partnering arrangements can provide the key to reducing the infra-structure costs.

Partnerships

A lot of the work needed to maintain our site and facility infra-structure is currently subcontracted on traditional MoD customer - supplier type contracts. For the future we are striving to move to partnership arrangements, in which we have a more equitable share of risks in return for a more equitable share of benefits.

The benefit of partnering arrangements is that we work together more flexibly to solve problems and accrue benefits that we both can share, for example, by exploiting the ranges and facilities for uses other than their primary purpose, or by only switching on the facility when it is needed for use rather than keeping it ready for action at all times. One might even float the idea of 'T&E parks' akin to the more traditional 'science parks'.

We also need to work with other suppliers of facility based T&E both nationally and internationally, who are subject to the same issues as we are. We need to develop ways of harmonising our management and sharing of facilities, and this has to be much more than the occasional contract to use another supplier's facilities. It will require a meeting of cultures and minds, and will take a determined effort and time to really get it set up - but the benefits will be very worthwhile.

We also need to develop improved partnerships with our customers, so that we ensure that they get the best use of T&E facilities to help solve their problems and reduce their risks.

A lot of investment is needed to support the necessary cultural changes:-

- to introduce campaign teams and multi-skilling;
- to develop effective project, resource and facility managers who work together as a team and who network across facilities and ranges;
- to provide full empowerment of the local

teams to do the work and make changes for improvement;

- to develop trusting relationships for range support and exploitation;
- to establish arrangements with other national and international suppliers of range based T&E.

Theory into practice

I would now like to present a case history to illustrate the potential of the management methods I have just outlined.

The ranges sector is in the throes of defining the future of 3 of its land ranges. For a number of reasons the customers' needs to use these ranges have declined and the ranges, because of their history, have duplication of capability and excess capacity.

The following figure shows the level of T&E work we expect for the 3 ranges, measured in terms of projected customer income over the period 1996 to 2001. Under the trading fund we now collect all the costs of operating the ranges, and this showed that a required income of £40m pa was needed when the ranges joined DERA in 1995, to meet the requirements of the trading fund (ie cover costs plus standard return to Treasury).

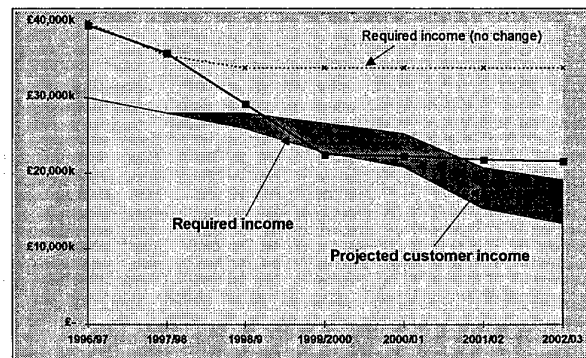

Income requirements - T&E land ranges

By simply squeezing costs and curtailing all investments, the required income to cover the costs of the ranges can be reduced to about £35m per year. However, as can be seen from

the above figure, this is nowhere near enough to make the ranges viable in the face of the falling customer demand.

By implementing some of the fundamental changes outlined above, the required income can be reduced to about £22m per year, whilst still retaining investments for the future, and this is much more in line with projected customer income. I also believe that our customers will find that we will become a much more focused and responsive organisation. I would add at this stage that we are not there yet, as we are now in the middle of making these changes. I hope I can report success at the next conference in 2 year's time!

Evolving nature of T&E

As we try to predict what the future holds for T&E ranges and facilities, the key factors to be considered are:-

- how will the defence equipment procurement process develop and what will customers require by way of T&E in this process;
- what systems (or technologies) are being developed which will require T&E results and services;
- and what new technologies can be used in our facilities to provide better results and knowledge capture to meet future T&E requirements?

The process for defence equipment procurement in the UK is currently under close examination as part of the Strategic Defence Review, and whilst details of any alternative approaches to current procurement practices are not yet known, it is likely that a controlled evolutionary approach to upgrading operational capabilities will come into play.

Factors that will gain in significance are:-

- increased use of modelling, stimulation, simulation and synthetic environments to evaluate options for enhancing capabilities, provide training environments, and to

provide reference and specifications for accepting new equipment;

- international projects for equipment procurement;
- technology insertion, including the use of off the shelf technology / systems;
- shortening of procurement timescales;
- the emerging paradigm of systems engineering to provide a framework for the whole process of capability enhancement.

A representation of systems engineering is illustrated in the following figure.

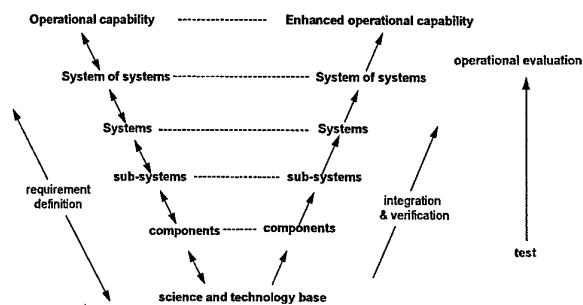

Systems engineering

Operational capability is provided by the totality of systems (including people and the operational procedures and equipment they use) and this "system of systems" can be broken down into the individual systems and then individual system components which ultimately depend on the available underpinning science and technology. Systems engineering provides the discipline for the specification, control, acceptance and traceability of changes made to the system configuration.

During a particular system procurement, the options can be evaluated at various levels from "system of systems" down to, perhaps, the component level to determine how enhancements to operational capability can be made.

This is an interactive process, and once a preferred option begins to crystallise, then specifications for its acceptance must be

established - so when the change is made we can measure that it has met its success criteria.

It is to be hoped that by undertaking the option evaluation correctly, the process of synthesis of the preferred option and its eventual integration into the system of systems becomes a low risk exercise, and T&E has a significant part to play in this process.

During requirements definition, T&E will be used to collect fundamental real world information for input into the models use for evaluating options. For ranges this means providing a safe space to conduct large scale experiments and measurements on various system components and technologies. Also at this stage, the methods and then the complementary specifications for acceptance of the options selected for implementation must be compiled.

Once we move into the development and integration of components and systems, then verification is necessary.

Whilst modelling and stimulation will undoubtedly play a much larger role than in the past for acceptance evaluation, there will still be a requirement for testing at the component level, and "system of systems" testing at the highest levels where T&E will be much richer - perhaps including operational evaluation with operators, operational procedures and training.

The results of the "system of systems" level T&E is then feedback to the assessment of needs for the next phase of enhancing capability.

In this model, T&E using range facilities can now be seen as supporting all phases of a process of incremental "improvement of capability" - and is in fact being used for through-life risk reduction.

The second factor that will drive the future of facilities (retention or enhancements) is clearly the types of system and equipment that have to

be measured. Trends for the future may well be:-

- a move to autonomous systems - a step beyond smart weapons - made possible by miniaturisation of powerful processors and sophisticated sensors;
- systems that can influence wider geographical areas - long range weapons, wide area sensors (and including command and control);
- more off the shelf systems;
- influence of counter-measures;
- 'smart' materials which adapt to the environment;
- non-lethal weapons;
- UAVs;
- stealth technology;
- and more interest in the performance at the system integration level rather than just the component test level.

The third factor affecting the future of the ranges is to provide the capability to meet the above requirements for measurement.

This will require significant investment in new and upgraded facilities that are already deemed to be expensive!

The future

And so to the future!

Taking into account the factors outlined above, I believe that working together on a National and International basis is the only viable way forward for T&E ranges and facilities.

Sharing expensive facilities that are only used occasionally makes sense, and mirrors the move towards multi-national equipment procurement programs.

However, to work together we need to have a common vision of where we are going and how T&E range facilities might fit into the future.

There are many ways of looking at this, and I put forward the following diagram representing what we should be striving towards - namely, closer integration of results from real world measurements with the models that support the development and implementation of enhanced operational capability.

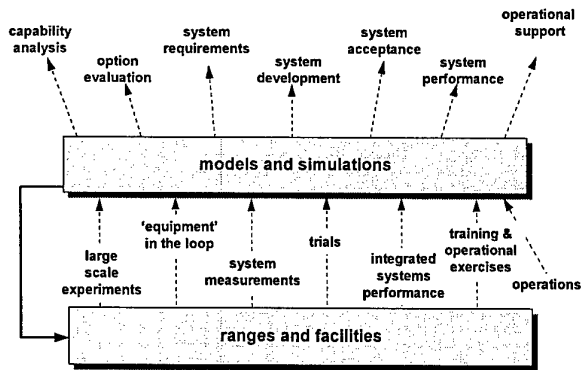

role of test and evaluation

I would welcome views and suggestions on how we might do more together, to define a common vision for the role of T&E ranges, and to take the necessary steps to realise it.

Thank you.

**Selling Change in the "New" Boeing Company:
Integrating 600 Laboratories**
Mr W E Newman and Mr R J Jablonski, Boeing
Information, Space & Defense Systems Group, USA

SELLING CHANGE IN THE "NEW" BOEING COMPANY: INTEGRATING 600 LABORATORIES

William E. Newman

Richard J. Jablonski

Phantom Works

Boeing Information, Space & Defense Systems Group

Seattle, WA USA

Abstract

The *Information, Space and Defense Systems (ISDS) Group* of The "new" Boeing Company bears slight resemblance to the former *Boeing Defense and Space Group*. The merger of Boeing with Rockwell and then McDonnell Douglas created a complex marriage of different product lines, cultures, accounting systems, personnel systems, and management styles. Our differences became particularly obvious when we considered the options of how to integrate the heritage management philosophies and operating systems for the combined 600 Research, Development, Test & Evaluation (RDT&E) laboratories and test facilities of these three companies. A fundamental question was how to strategically integrate and manage similar yet widely separated lab resources, operate them as a business in order to maximize operational efficiency, and yet optimize support to customers, regardless of lab location.

In November 1997 the *Information, Space and Defense Systems Group* created *Enterprise Laboratories*, a new Group-wide laboratory management organization under *Phantom Works*, one of the four business units of the new Group. Chartered to make strategic consolidation recommendations as their initial thrust, *Enterprise Laboratories* was the Group's first organizational element to operate across all sites and

business units. Their goal was to find new efficiencies and attendant savings through the consolidation of laboratory assets across the former companies. To reverse an old adage, the sum should be less than the parts. Three months later *Enterprise Laboratories* presented 145 recommendations, nearly equally divided between closures and consolidations, totaling \$100 million in 5-year gross savings. Group leadership approved these recommendations in March 1998. Along with this approval, they also chartered a new management philosophy for these 600 general usage labs and renamed the organization *ISDS Laboratories*.

The tasks of *ISDS Laboratories* now center on delivering this first round of identified savings while finding ways to provide laboratory managers and their customers additional increased efficiencies. To achieve this goal the existing management of the heritage companies must also take ownership of the change process. In short, all management levels must believe that the end state will benefit their customers, their people, and themselves. The new voyage has begun but is far from over.

The Mergers

Following the approval the Boeing merger with Rockwell's similar defense and space interests, we commenced a study in January 1997 to integrate the

Boeing defense and space laboratories with like facilities of our new Rockwell teammates in southern California. This 5-month study culminated in 116 recommendations for closure and consolidation. The integration approach was to first gain understanding of the capabilities, equipment condition, and business situation for all Boeing and Rockwell labs by using a "inter-company" integration team of experts to evaluate consistent data in conjunction with actual tours of sites and labs. A standard laboratory data sheet was created to capture these physical, operational, and business aspects for an individual facility. The lab managers at all sites then completed data sheets for each lab and test facility. These laboratory data sheets have become the core of an electronic relational data base that provides the common denominator for strategically managing laboratories across the *Information, Space and Defense Systems Group*.

The consolidation recommendations submitted in June 1997 were the consensus of this "inter-company" team. However, difficulties were encountered in implementing the recommendations because of three main reasons: (1) the lack of a senior lab manager empowered to lead the implementation phase, (2) the lack of a company-wide finance mechanism to absorb (or at least absorb) the non budgeted implementation costs, and (3) buy-in by the affected middle managers of the heritage companies. These realities further abetted the understandable human nature to protect one's immediate organization from upper level management decisions, which upset the local status quo. These were important lessons learned for the next merger effort with McDonnell Douglas.

July 1997 brought the stockholders' approval of the merger with McDonnell Douglas, and this had the greatest impact on the defense and space programs of The (new) Boeing Company, starting with the title: *Information, Space and Defense Systems (ISDS) Group*. The Group is comprised of four operating business units: *Space Transportation*, primarily located in Southern California, *Aircraft and Missile Systems*, primarily located in St. Louis, *Information and Communication Systems*, primarily located in Seattle, and *Phantom Works*, the advanced technology and cross-site enabling network which supports the other Group business units at all operating sites. Hence, it was decided to place the management structure for hundreds of labs across the nation in the Phantom Works organization.

Enterprise Laboratories became an official element of *Phantom Works* in November 1997. From the outset, there were two central tenets of this new organization: (1) to base integration and other major lab/test facility decisions on detailed business case analyses supported by accurate data, and (2) to centrally coordinate strategic management actions for similar facilities across the business units and sites. The issue of managing daily lab operations will be discussed later in this paper.

The Process

The modus operandi for the new organization was to first group all general usage labs, regardless of location, into a manageable number of categories with similar technical and operational requirements. The eight categories selected were: Aerodynamics & Structures, Electronics, Signature/EMI/EMC, Modeling & Simulation/ Systems Development/MMI,

Propulsion/Physics/Fluid Mechanics, Environmental/Mechanical, Materials & Processes, and Metrology. At the outset, there were approximately 600 labs among these categories. (It must be noted here that within the Group there are an additional 160 labs, not under Enterprise Laboratories management, which are dedicated to, managed, and directly funded by individual programs, and these are typically systems integration labs.) Each lab technical category was assigned to a Laboratory Strategic Manager (LSM) who had expertise in the required disciplines, and these managers were assigned from laboratory management positions within the former heritage companies. These eight technical groupings permitted a reasonable number of labs for the assigned leaders to manage.

The next step was to determine the schedule and process for creating a first round of integration recommendations. With the *Enterprise Labs* team now comprised of people from the three former companies and their major geographical regions, it became obvious that the LSMs would have to personally visit and review all 600 general usage labs. Despite a larger number of labs to assess, it was decided to reduce the schedule to three months by having each category of labs visited only by the LSM having cognizance for that category. They set their own travel schedule for gathering data and traveled alone or with a very small staff. Their primary objectives were to validate the information provided on the laboratory data sheets, brief local laboratory managers on the consolidation process, and develop a detailed contact list for future strategic planning.

The team maintained a very fast pace during the site visit-data gathering phase.

Two interim situation reports to the executive management of *Phantom Works* punctuated this three-month phase. During these briefings the team received guidance on the changing terrain of the merger and where to focus their efforts. In the final month they created business cases for each recommendation based on the assessed data, and a criterion was established for a closure/consolidation decision. All business unit stakeholders attended and critiqued the final presentation of recommendations. The results are covered in a later section of this paper.

Laboratory Ownership

From the start of the *Enterprise Laboratories* integration study, the concept of “centralized decision authority” over all ISDS general usage labs, for whatever purpose, caused lively debates regarding lab ownership, and who had what authority over these key engineering resources. First, the new Group business units, created from the heritage companies, still maintained the overhead budget “pools” and the numerous financial accounting systems. This situation remained virtually unchanged after the mergers, and major changes to these basic business systems may require years. Second, the strong preeminence of program management teams in the heritage companies generated an understandable suspicion of any new “central” organization claiming to have authority over their key engineering laboratories and test facilities. Finally, there will always be middle management resistance to change in large organizations, even when significant events like nation-wide mergers clearly indicate the need for it. The merger of three large, distinct cultures resulting in a new company of

235,000 people certainly provides fertile ground for the growth of such disagreement.

Management of Daily Operations

Hundreds of full-time “overhead” personnel are required to maintain and operate the 600 general usage Group laboratories. A central assumption from the beginning was that the day-to-day support of programs would eventually be managed under *Enterprise Laboratories*. Obviously, if this happened, large portions of the existing lab management organizations at all sites would have to become part of Enterprise Labs’ line management authority. In the early months following creation of *Enterprise Laboratories*, this transformation was discussed only in very broad terms, adding further concerns to those of the ownership issue.

The Results

The results of the team’s efforts to date are gratifying. At the end of the three month effort, they recommended 76 laboratories for closure and 69 laboratories for consolidation. When implemented, these actions will result in savings to The Boeing Company approaching \$100 million over five years. The primary contributors are operating costs in the form of square footage and employee reductions, plus cost avoidance for future maintenance and capital improvements.

The Laboratory Strategic Managers have established personal contact with the individual managers for each laboratory in their category. These contacts, combined with their understanding of the lab capabilities and assets, enables the

LSMs to plan strategic investments and resource allocations. Their perspective of viewing laboratory capabilities and needs across the Group, independent of location and heritage company affiliation, assures strategic decisions in the best interests of Boeing.

An expanded Laboratory Data Base now includes increased levels of detail and is available to all affected Boeing personnel. The relational data base tools provided with the software application allow users to sort and format the information according to their needs. Information on laboratory capabilities is available to all internal customers for their use in proposal planning and resource identification. The data base will be available on a web server by mid 1998 thereby enabling easier access for users and customers. Further expansion will include capital and Internal Research & Development (IR&D) planning information.

The Future

As the *Information, Space, and Defense Systems Group* approved these recommendations, they also introduced a new laboratory management philosophy and structure. First, the title was changed to *ISDS Laboratories*, reflecting the Group-wide scope of strategic lab management. Second, *ISDS Laboratories* received a clear mandate to perform these strategic management functions for all 600 general usage labs across ISDS. The day-to-day management of projects will continue to reside within the regional site management structures. However, four of the team’s eight lab category managers are also “dual hatted” as Regional Site Managers. This new feature provides close connectivity

between the strategic and daily management roles. The team is organizing the next round of laboratory integration recommendations. Strategic management functions such as major resource allocation (capital investments, IR&D) and major lab process improvements (e.g., general purpose test

equipment management) also became the purview of *ISDS Laboratories* with this modified organizational structure. Boeing continues to seek ways of improving shareholder value, and efficient laboratory and test facility management structure will greatly contribute to our return on net assets.

Test Range – A Profit Center? The Israeli Experience
Mr A Leshem, Weapon Test and Evaluation Center,
RAFAEL, Israel

Test Range-A Profit Center ? The Israeli Experience.

By Aaron Leshem

Director of EW Test Range and Instrumentation Department.
Weapon Test and Evaluation Center (WTEC), RAFAEL, Israel
Dep. 3M, POB 2250 Haifa, Israel
Tel. 972-3-5723204, Fax. 972-3-5723240

Presented at the 3-rd Test & Evaluation International Aerospace Forum
June 1998, London

Rafael's WTEC has grown together with weaponry development in Israel. In the last decade, the Israeli MOD budget for armament development has been reduced which implied less new armament developments. This result in fewer test missions to be performed at WTEC.

This article presents WTEC experience and strategy to face the challenge of being more efficient in performing the T&E mission. This goal is achieved by enhancing the productivity and reengineering the T&E process.

Rafael presentation

RAFAEL, the Armament Development Authority of Israel, has been developing and supplying high technology weapon systems for close to 50 years. With a combined staff of several thousands of engineers, scientists, technicians and other skilled personnel, it is the largest R&D organization in Israel for weapon systems.

At RAFAEL research and exploratory development are an on-going process. There are short range immediate response projects to meet the urgent needs of the Israeli Defense Forces (IDF) and long range projects in a wide range of disciplines.

RAFAEL's products and systems are in operational use in every branch of the IDF and by other customers both in Israel and abroad. The weapon systems have been proven in combat time and time again.

Rafael offers a wide range of weapon systems in various fields, including missiles, rockets, EW, special purpose computers and thermal imaging systems. Well known products include the PYTHON 4 air to air missile, BARAK/ADAMS vertically

launched point defense missile, POPEYE air to ground missile and more.

The most modern facilities backup RAFAEL's technical know-how. World class simulation centers, antenna engineering facilities, anechoic chambers, and specialized laboratories dedicated to the development of electro-optics, micro-electronics, computer technologies, fire control and missile propulsion and the Weapon Test and Evaluation Center (WTEC), the National over land test range.



WTEC Presentation

WTEC is located in the southern part of Israel, in a practically uninhabited desert area. It comprises 450 sq. km of ground area, of various terrain textures and landscapes, from which more than 10000 sq. km of air space are controlled. Large military fire-zones adjacent to the test range enable extension of test ground area whenever required. The test range is accessible either by road from major cities in Israel, or by air using one of two nearby airfields. The area within the range is accessible for visual inspection and measurement of fragment dispersion of sophisticated warheads.

The clear, dry desert climate, with only 10 days of rain per year, offers excellent visibility and allows maximum utilization of the high precision optical instrumentation.

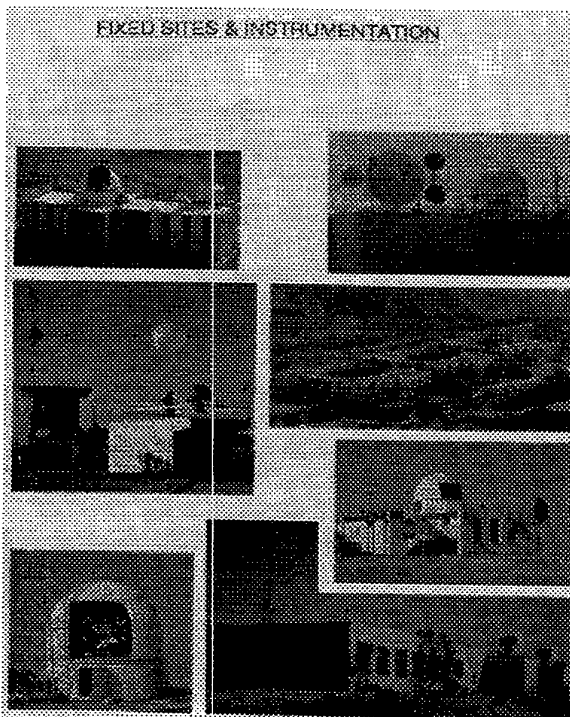

The main test range facility has a trilateral configuration with three fixed sites located on ridges overlooking the central impact zone and in advance prepared sites which allow deploying the mobile instrumentation

in order to cover optimally the planned flight path.

The test range size and environment enable the operation of high-energy missiles, with minimal outside interference.

Particularly impressive is the wide range of sophisticated equipment, both fixed and mobile, which together provide optimal geometry tailored for each test mission.

WTEC operates various types of measuring instruments and data gathering devices, as well as EW threats and emitters.

The test range instrumentation includes optical tracking mounts, cinetheodolites, instrumentation radars, tactical search radars, telemetry receiving stations, meteorology and surveying geodetic equipment.

EW threats, fixed and mobile, consisting of replicas as well as authentic systems, allow system survivability testing under realistic threat environment simulation.

A large arsenal of various high speed film and video cameras, shuttered video and IR cameras increase electro-optical instrumentation versatility and data accuracy, and shorten the analysis time-cycle.

All the tracking systems, including the EW systems, are linked and controlled by the computerized Command and Control Center. The command rooms contain consoles with color graphic displays, video monitors, real-time telemetry displays and various types of communication means.

The core of the control computer system, consists of two VAX 4000 series computers, which together with double peripherals provide backup, as well as ample off-line computing power. The VAX computers constantly update the display stations in the control rooms, by data broadcast over a local area network system.

Mutual slaving, data processing in real time, graphic and alphanumeric displays of all measurements and simultaneous tracking of multiple targets, all in real time, are among the many capabilities of WTEC.

History background.

Testing at Shdema test site began in the mid 1950's with only tents for lodging and jeeps for transportation.

WTEC began as a small photographic unit with a mission to test simple weapons which were developed by the young Israeli armament industry at this time.

Small guns, rockets, grenades and mines were tested and evaluated at the test site.

In the mid 70's the first instrumentation radars and cinetheodolites were purchased and integrated into the test range.

During the 80's all tracking instruments were computerized and connected via communication lines to a central computer. After this stage the method of mutual slaving by a strong central computer could be easily adopted and implemented.

In 1988, as a part of major changes in RAFAEL, WTEC was declared to be a profit center. How this decision effected the future will be described below.

In 1991 the mobile test range had its first appearance. It was during the Desert Storm War, that the mobile test range was moved to the Tel Aviv area to track the incoming SCUD missiles and examine the performance of the Patriot missiles being launched against them. This was a real challenge for our operators to perform their mission in a battle situation.

In 1994 the Electronic Warfare Test and Training Facility was merged with WTEC . This was the drive and the opportunity to establish the Integrated Test and Training Range (ITTR). . The mission of ITTR is :

- Test and evaluation of weapons under realistic operational conditions, including real threats and replicas.
- Analysis and evaluation of EW systems
- Training of aircrews and EW operators
- Real time control and debriefing for ground army exercises.

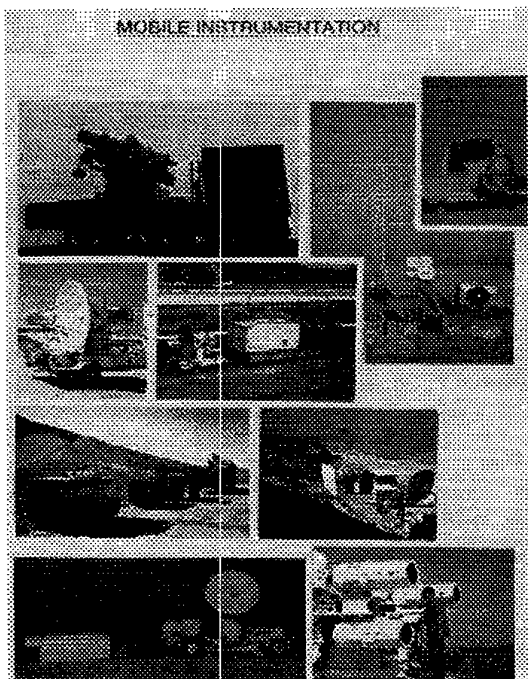

Management decisions.

Presented here are two major managerial decisions, which were taken during the last decade. These decisions have changed the management infrastructure of the facility, had a major influence on the test range development and have shaped its position as the leading test and evaluation facility in Israel.

The first decision was that WTEC become a profit center and act as an independent economic entity (1989). The second decision was to merge the EW test and training facility with WTEC (1994).

WTEC - A profit center

Over the past decade the Israeli Ministry of Defense and RAFAEL have been facing reduced budgets, resulting in a decline in the numbers of systems developed and tests performed at WTEC.

Until 1987 WTEC did not govern itself according to economical principles. All the services were given to MOD organizations without charge. The decision that WTEC will be a profit center was part of the larger step taken by IMOD to convert RAFAEL status from a department in IMOD to a fully owned government company.

This decision which was not implemented as of now caused nevertheless a major change and had an extreme influence on WTEC.

We had to redefine all the processes and tasks of the test range personnel, yielding a dramatic reduction of personnel (over 40%) which included recruiting young and skilled engineers and technicians,

We outsourced a lot of functions which were not part of our core competencies, so we could focus on our main expertise. For example, we decided to outsource all the activities concerned with food, lodging, garage, depots, transportation (partially) etc.

The savings from this activity reached over 10 percent.

We changed our organizational structure into a compact and efficient one. The organization chart became simpler, with less distinct groups leading to higher operational effectiveness and smaller overhead cost.

We have changed the organization culture by addressing the workforce moral and establishing open communications and decision sharing. We established commercial charge policy, and charged money for our services. We initiated new activities, such as operational testing and monitoring services for ground forces training.

We have fully adopted the total quality approach in the test and evaluation activities, with an emphasized focus on the customer and his needs. We undertook a new approach towards the T&E process by defining it as a service given to the customer.

This attitude was fully adopted and assimilated at all levels of the test range personnel, starting with the management level down to the instrumentation operators in the field.

The results of all these activities were very impressive.

Within three years the test range became a professional, compact, efficient and effective organization.

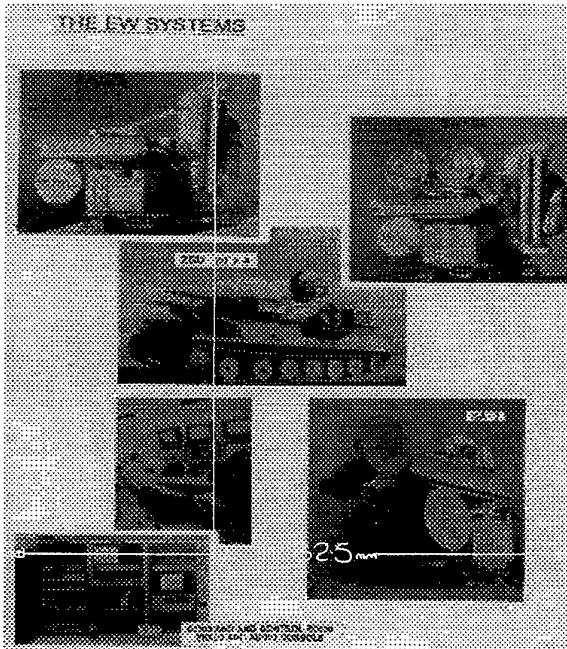

Merger with the EW facility.

The second decision was the merging with the EW facility. This decision was taken when WTEC was already an efficient organization. The merger was done by including the EW facility as a part of the instrumentation department of WTEC.

This had two major impacts:

- The merger required an intensive and comprehensive development effort, which resulted in the establishment of the Integrated Test and Training Range. Most of the development was performed by WTEC personnel and this, by its own virtue, had a positive impact on the test range activities.

- Due to the similarity between the two organizations and the increase in productivity (training and motivation) we could reduce our combined personnel by an additional 15 percents and increase the number of missions that we were able to perform.

This last decision was the prime cause that led WTEC to become economically balanced. Today we are proud to have a facility which is one of its kind in the world, operated by a small but very professional and highly motivated group.

Summary

WTEC has grown together with weaponry development in Israel and became an advanced and sophisticated test range which enables to test and evaluate the most advanced weapons and EW systems.

Two major managerial decisions have shaped our test range, its activities and performance.

Acting as a profit center led the management to look for ways and means to increase productivity and to reengineer the T&E process. Managers leadership and personnel responsibility and maturity caused this mission to be successful.

Now we are in the process of defining and designing the Virtual Integrated Test and Training Range (VITTR) which will enable missions in a combined real-virtual domain. This will be accomplished by connecting the ITTR with Israeli National Battle Laboratory (INBL) and additional simulator facilities in Israel.

References

1. Weissman S. et al., "Weapon Test and Evaluation Center", RAFAEL's Publication, Nov. 1991.
2. Weissman S. et al., "Mobile Test Range", RAFAEL's Publication, Jan. 1993
3. Leshem A., "T&E in Israel" Int. T&E panel presentation, ITEA Int. Symp., 1993.
4. Weissman S., "The Role of Mobile Instrumentation in RAFAEL's Test Range" The 3rd Aust. Inst. & Meas. Conf., 1994.
5. Leshem A., "Future of T&E - International Dimension", Annual ITEA Int. Symp., 1997.

**Distributed Simulation and Test and Evaluation:
A Midterm Report on the Utility of
Advanced Distributed Simulation to Test and Evaluation
Col M E Smith, Joint Advanced Distributed Simulation
Joint Test Force, US Air Force and Dr L McKee, SAIC, USA**

**DISTRIBUTED SIMULATION AND TEST AND EVALUATION:
A MIDTERM REPORT ON THE UTILITY OF
ADVANCED DISTRIBUTED SIMULATION TO TEST AND EVALUATION**

Colonel Mark E. Smith, USAF

Dr. Larry McKee, SAIC

Joint Advanced Distributed Simulation Joint Test Force

11104 Menaul Blvd. NE, Albuquerque, New Mexico, USA 87112

Abstract

The Joint Advanced Distributed Simulation Joint Test Force (JADS JTF) is chartered by the U.S. Office of the Secretary of Defense (OSD) to determine the utility of advanced distributed simulation (ADS) for both developmental and operational test and evaluation (DT&E and OT&E). The program is at its midpoint, and this paper is designed to provide a progress report on the lessons learned to date on the use of ADS in test and evaluation (T&E).

The paper opens with a brief overview of ADS technology and then a short description of the JADS Joint Test and Evaluation (JT&E) program. Third, the main portion of the paper will discuss the results and lessons learned during the ADS-enhanced testing conducted throughout the first major phases of the JADS JT&E program. Fourth, the JADS study on the linking of electronic warfare (EW) test facilities, the Threat Systems Linking Architecture (TSLA) Study, is briefly described. Finally, other considerations will be offered for the T&E professional interested in whether ADS might be a suitable test tool.

The material in this paper fuses material from other JADS documents prepared by many members of the JADS JTF. Readers are encouraged seek more information JADS has compiled either via the address above or their web site (<http://www.jads.abq.com>).

Overview of ADS (Ref. 1)

Since the mid-1980s, rapidly evolving information systems technology has been put to work in support of U.S. Department of Defense

(DoD) needs. Early efforts were conducted jointly by the Defense Advanced Research Projects Agency and the U.S. Army. This early project was named Simulation Network (SIMNET), and it was sharply focused on training applications. Conceptually, the project was directed toward linking training devices (simulators) with human operators in the loop at distributed sites in a common virtual environment in near real time. SIMNET evolved to distributed interactive simulation (DIS), a technology implementation which is more flexible and far reaching. Formal industry standards have been established for DIS. In turn, DIS is giving way to high level architecture (HLA), a technical approach championed by the U.S. Defense Modeling and Simulation Office.

JADS uses a more generic term for the technology – ADS. This is defined as the technology and procedures that provide a time and space coherent, interactive synthetic environment through geographically distributed and potentially dissimilar situations. Any combination of live, virtual, or constructive simulation of people and/or equipment can be used. ADS is the concept; DIS and HLA are applications of ADS.

Overview of JADS JT&E

Background (Ref. 1)

Because of widespread interest in using ADS technology to support T&E, the JADS JT&E program was nominated for feasibility study in 1993. The nomination was motivated by the T&E community's concern about long-standing

test constraints and limitations, and the potential utility of ADS for relieving some of those constraints and limitations. However, there was widespread skepticism that ADS might not be able to deliver high-quality data demanded by the T&E community. The Services concurred with the need for a rigorous examination of ADS utility to testing, and OSD's Director of Test, System Engineering and Evaluation chartered JADS as a full joint test program.

JADS JT&E Charter (Ref. 2)

The basic JADS JT&E program was chartered in October 1994 to investigate the utility of ADS for both DT&E and OT&E. More specifically, JADS is to investigate the present utility of ADS, to identify critical constraints in using the technology, to develop the methodologies in using ADS in various T&E applications, and to provide growth requirements for ADS so that as it matures it better meets the needs of the T&E community.

At the time of chartering, OSD tasked JADS to investigate the possibility of specifically examining ADS utility to EW T&E. This additional facet of the program was subsequently chartered in August 1996 (Ref. 3).

Test Approach

To accomplish this charter, JADS is conducting three series of ADS-enhanced tests in widely different areas to determine the utility of ADS. Representative "systems under test" are used, ones that have already undergone testing and have been fielded. Significant system performance data is available then for comparison with the data obtained in the tests introducing ADS as a methodology. The three specific test programs are the System Integration Test (SIT) utilizing two air-to-air

missiles (AIM-9M Sidewinder and AIM-120 Advanced Medium Range Air-to-Air Missile (AMRAAM)); the End-to-End Test (ETE) using the Joint Surveillance Target Attack Radar System (Joint STARS) as a representative command, control, communications, computer, intelligence, surveillance and reconnaissance (C4ISR) system; and the Electronic Warfare (EW) Test, utilizing the ALQ-131 self-protection jammer (SPJ).

System Integration Test (Ref. 4)

SIT evaluated the utility of using ADS to support cost-effective testing of an integrated missile weapon/launch aircraft system in an operationally realistic scenario. The purpose of SIT also included the evaluation of the capability of the JADS Test Control and Analysis Center (TCAC) to control a distributed test of this type and to remotely monitor and analyze test results.

SIT consisted of two phases, each of which culminated in fully linked missions. The missions simulated a single shooter aircraft launching an air-to-air missile against a single target aircraft. In the Linked Simulators Phase (LSP), the shooter, target, and missile were all represented by hardware-in-the-loop (HWIL) laboratories. LSP testing was completed in November 1996. In the Live Fly Phase (LFP), the shooter and target were represented by live aircraft and the missile by a HWIL laboratory. LFP testing was completed in October 1997.

Linked Simulators Phase The LSP test concept was to replicate a previous AIM-9M-8/9 live fire profile in an ADS configuration and compare missile results for the LSP trials to those from the live fire test. The LSP test configuration is shown in Figure 1.

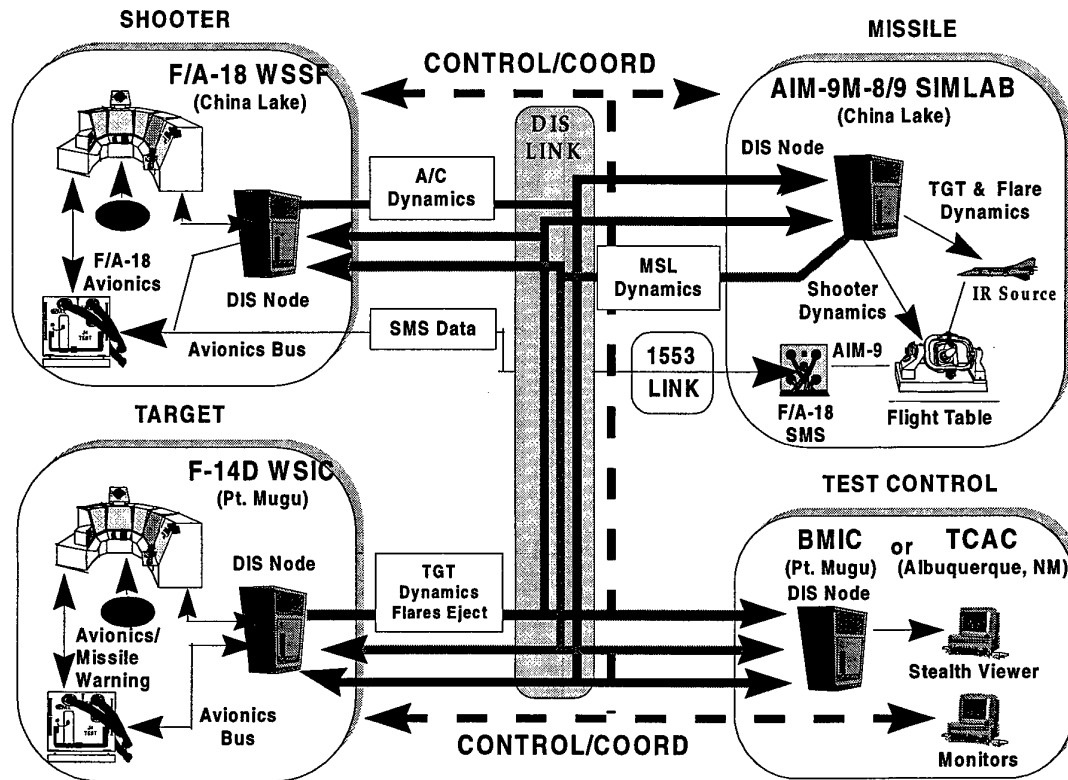

Figure 1. Linked Simulator Phase Configuration

The F/A-18 Weapon System Support Facility (WSSF) at China Lake, California, and the F-14D Weapon System Integration Center (WSIC) at Point Mugu, California, were the shooter and target, respectively. The shooter “fired” the AIM-9 in the Simulation Laboratory (SIMLAB) HWIL facility at the target which could respond with countermeasures. Runs were controlled from a test control center which ensured all nodes were ready for each run, issued start/stop directions, and processed data packets for real-time analysis of system performance. Test control was exercised from the Battle Management Interoperability Center (BMIC) at Point Mugu while the JADS Joint Test Force was physically relocating. Control switched to the JADS TCAC in Albuquerque, New Mexico after the move was complete.

Live Fly Phase The LFP test concept was to replicate previous AMRAAM live fire profiles in an ADS configuration and compare missile results from the LFP trials to those from the live fire tests. In the LFP, ADS techniques were used to link two live F-16 aircraft (flying on the Gulf Test Range at Eglin Air Force Base, Florida) representing the shooter and target to an AMRAAM HWIL laboratory (also at Eglin) representing the missile. This configuration allowed data from live sources to drive the HWIL laboratory for more realistic missile results and is shown in Figure 2.

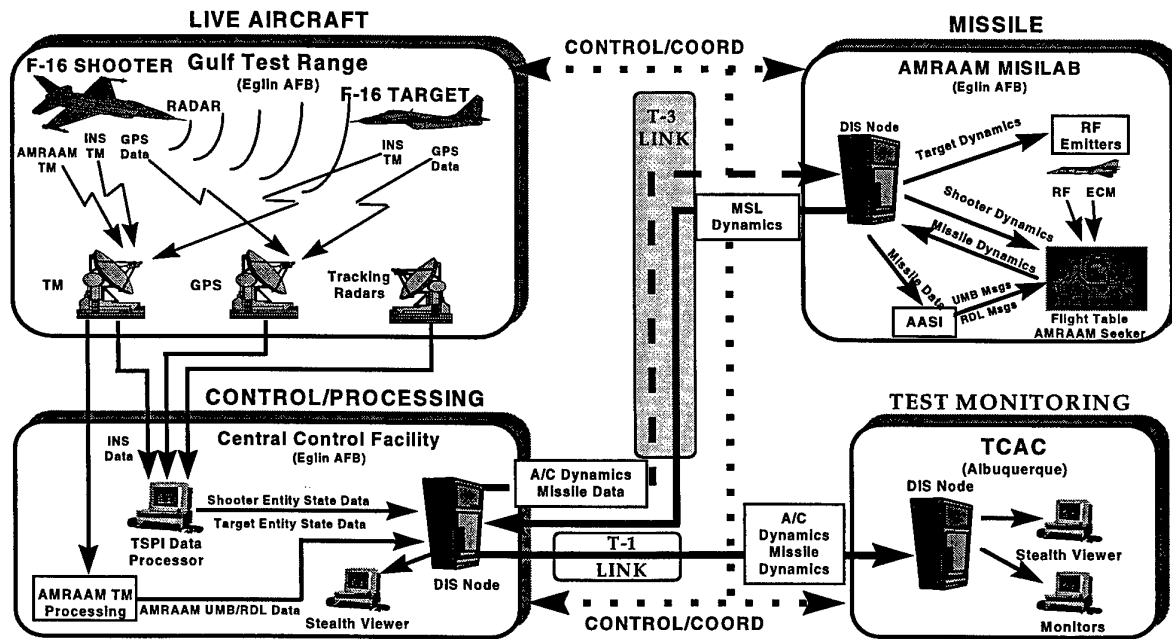

Figure 2. Live Fly Phase Configuration

Global positioning system (GPS) and telemetry (TM) data were downlinked from the aircraft and passed to the Central Control Facility (CCF) at Eglin. GPS, inertial navigation system (INS), and tracking radar data for each aircraft were combined by the TSPI (time-space-position information) Data Processor (TDP) in the CCF to produce optimal entity state solutions. The aircraft entity state data were transformed into DIS protocol data units (PDUs) and transferred to the AMRAAM HWIL simulation at the Missile Simulation Laboratory (MISILAB) over a T3 link.

The shooter aircraft “fired” the AMRAAM in the MISILAB at the target and provided data link updates of the target position and velocity to the missile during its flyout. The AMRAAM seeker was mounted on a flight table and responded to radio frequency (RF) sources in the MISILAB which simulated the seeker return from the target, the relative motions of the

target and the missile, and electronic countermeasures (ECM). A link between the CCF and the JADS TCAC allowed JADS personnel to monitor and record the simulated intercepts.

End-to-End Test

The ETE uses distributed simulations to assemble an enhanced environment to be used for testing command, control, communications and computer (C4I) systems. The object is to determine if ADS can provide a complete, robust set of interfaces from sensor to weapon system including the additional intermediate nodes that would be found in a tactical engagement. The test traces a thread of the battlefield process from target detection to target assignment and engagement at corps level using ADS. Figure 3 illustrates the basic test architecture.

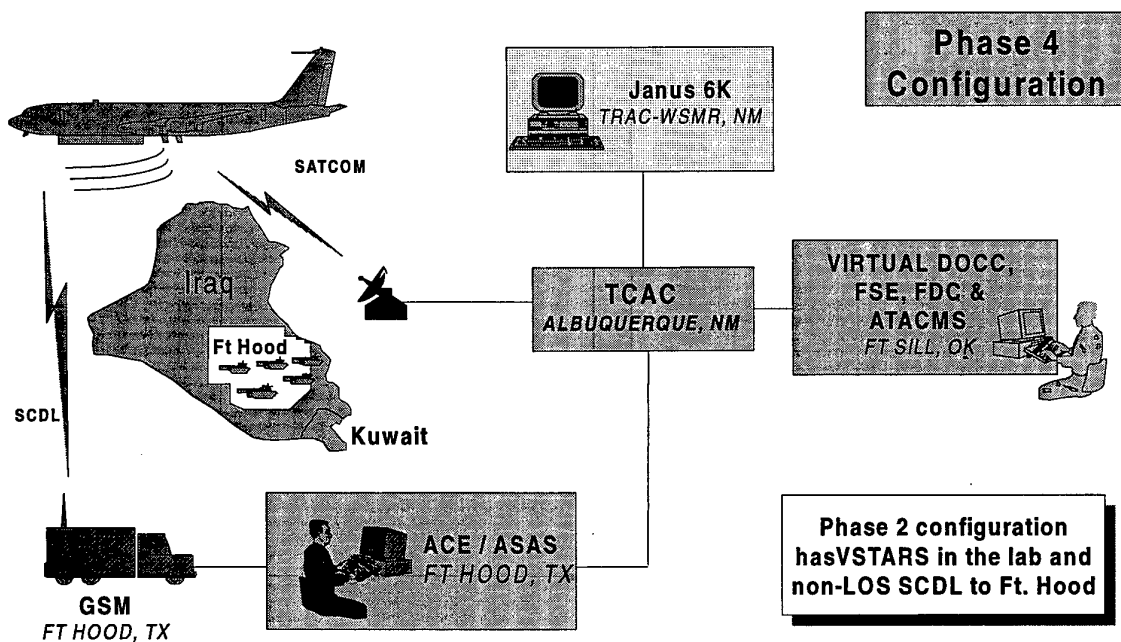

Figure 3. End-to-End Test Architecture

The ETE is a four-phased test. Phase 1 was largely developmental – constructing the various components necessary to executing later phases of testing. These components include a high fidelity emulation of the Joint STARS radar processes, called Virtual Surveillance Target Attack Radar System (VSTARS), which includes both moving target indicator and synthetic aperture radar modes of operation. Phase 2 links representative entities for the end-to-end process while the “system under test” is in a laboratory environment enabling JADS to explore the utility of ADS in the DT&E and early OT&E of a C4I system. Phase 3 hosts VSTARS on board the actual Joint STARS aircraft and performs final integration testing. Phase 4 is an actual live open air test with the aircraft airborne, with the environment augmented by ADS.

Electronic Warfare Test (Ref. 6)

JADS EW Test was chartered separately by OSD to examine the utility of ADS in EW T&E. To allow JADS to conduct a broad analysis of this domain and remain within very tight fiscal constraints, a “multi-vectored” approach is employed. JADS leveraged off the

U.S. DoD High Level Architecture (HLA) Engineering Prototype Federation for lessons learned in constructing and implementing a distributed architecture for EW T&E. At the bequest of DoD’s CROSSBOW Committee, JADS directed the TSLA Study, which delineates how to link DoD’s EW test facilities using the HLA. Third, JADS is participating with the U.S. Army in its Advanced Distributed Electronic Warfare System (ADEWS) test, a concept that provides EW effects on communications gear in the open air environment without the actual EW open air emissions. Fourth, JADS offers test agencies and program offices “comparison studies,” where a traditional test of a system is compared with an ADS-enhanced test to identify potential benefits in test thoroughness, time and money. JADS Flag Officer Steering Committee directed that these studies be performed after the JTF has performed its self-protection jammer (SPJ) test.

SPJ Test (Ref. 7)

The SPJ test has been designed as a three-phased test focusing on the U.S. DoD EW test process, and utilizes the ALQ-131 as its “system under test.” Phase 1 is a non-ADS test of the

SPJ on an open air range (OAR), augmented with data obtained by testing the ALQ-131 in a hardware-in-the-loop facility. The purpose of this test is to establish a baseline of environment and performance data which will be used to develop the ADS test environment for the following phases and will be the basis for determining the validity of ADS test results. Phase 2 is a test of a high-fidelity real-time digital system model (DSM) of the ALQ-131 linked with hardware-in-the-loop terminal threats and a constructive model of an Integrated Air Defense System (IADS). The threat laydown from the OAR is replicated in the synthetic ADS environment and the ALQ-

131 will be flown, via a scripted flight profile developed from the actual OAR flights, through the IADS, engaging the high-fidelity terminal threats. Phase 3 is a test of the SPJ installed on an actual aircraft located in an Integrated System Test Facility (ISTF). The facility will be linked with hardware-in-the-loop threats and the constructive model of the IADS using the same threat laydown as the previous test and controlled by the same scripted flight profile. Figure 4 illustrates Phases 2 and 3 of the SPJ test.

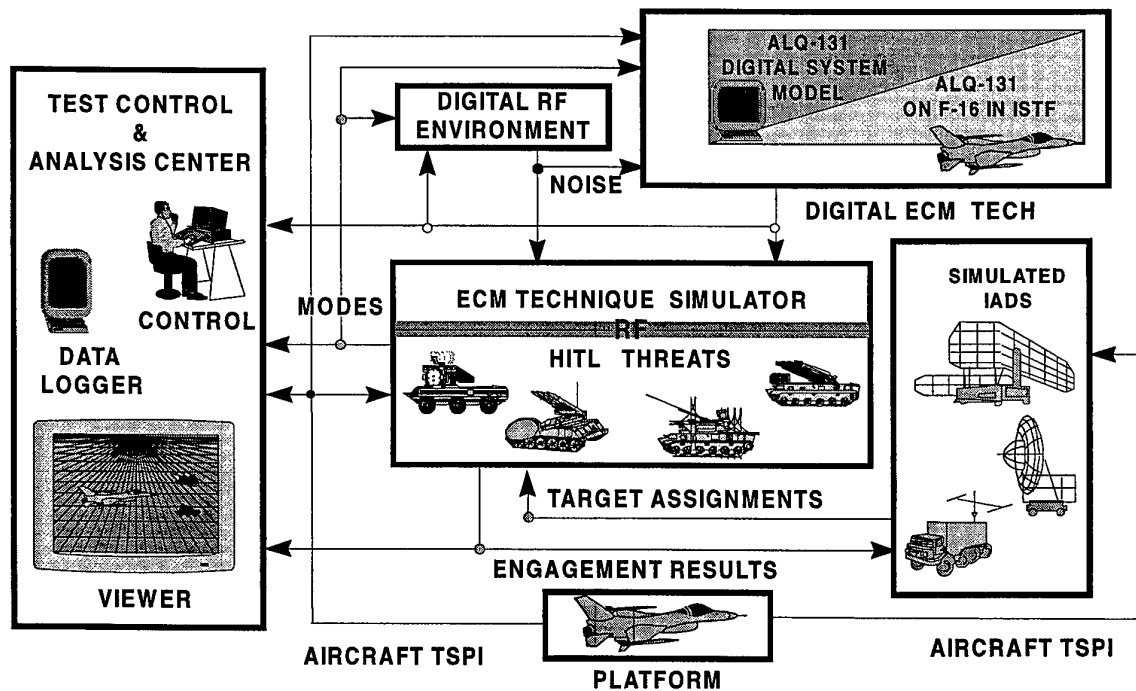

Figure 4. Self-Protection Jammer Phases 2 and 3

JADS JT&E Test Results

At the time of this writing, JADS has completed one phase of the ETE and both phases of SIT.

As the first phase of ETE was largely developmental, this section will focus on SIT results. (For a schedule of JADS test execution, refer to Figure 5).

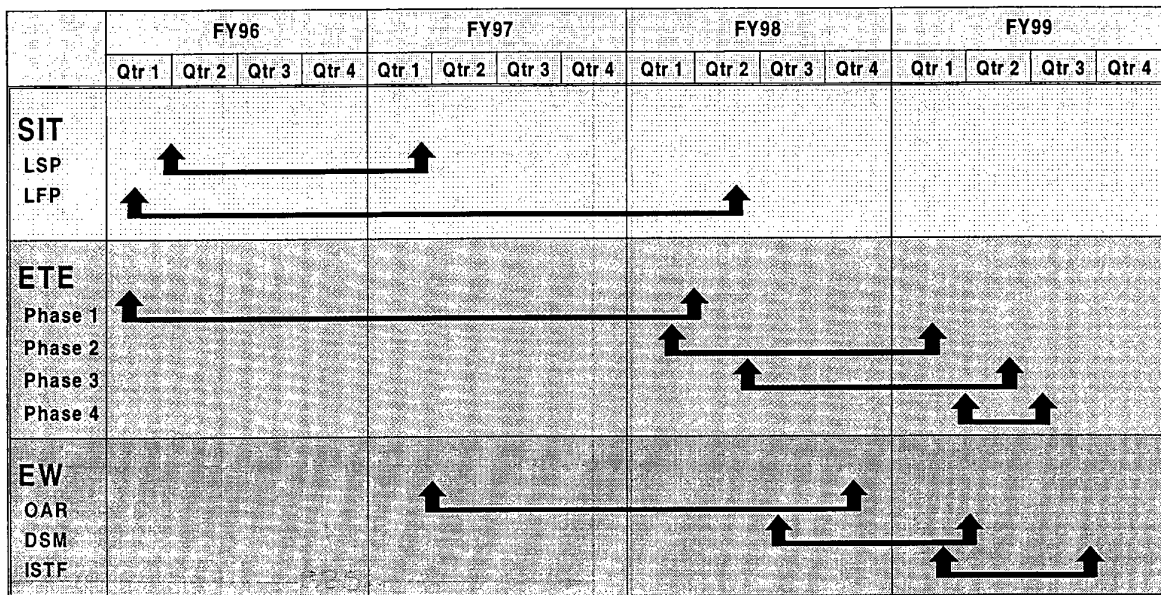

Figure 5. JADS Test Execution Schedule

Linked Simulators Phase Results (Ref. 8)

The key results from LSP testing were as follows:

- The simulation facilities were properly linked, and the missile flyouts were valid for the target representation in the Simulation Laboratory (SIMLAB). However, this target representation differed somewhat from the target data originating from the Weapon System Integration Center (WSIC).
- The manual method for replicating a given profile resulted in very good run-to-run reproducibility of the engagements.
- The average latency of all entity state data during the final mission were relatively small (<100 milliseconds from simulation to simulation) and consistent run-to-run. However, relatively large random latency variations were often observed which resulted in an uncertainty in the target location, as perceived in the SIMLAB.
- The ADS network provided ample bandwidth and no loss of connectivity during testing.

- There were no significant ADS-induced errors.
- The reliability of the long-haul network was very good, and the availability of the complete LSP ADS configuration was on the order of 85%.
- Test control procedures were refined throughout the preparation process and worked well during testing.

Live Fly Phase Results (Ref. 9)

The key results from LFP testing were as follows:

- The live aircraft were properly linked to the missile HWIL laboratory, and the Missile Laboratory (MISILAB) generated valid AMRAAM data during the engagement.
- Accurate time-space-position information (TSPI) solutions were generated by the TSPI Data Processor (TDP) to the order of one to three meters in position and one meter per second in velocity. This well exceeded MISILAB accuracy requirements.

- The shooter and target TSPI data were properly synchronized to each other and to the umbilical and data link messages for input to the MISILAB simulation.
 - Latencies during testing were relatively stable and consistent, but fairly large. The total latency of the MISILAB simulation was about 3.1 seconds. This large value of latency was due to the processing and buffering of the TSPI data to produce accurate and smooth solutions and to the synchronization technique used.
 - The ADS network provided ample bandwidth and no loss of connectivity during testing.
 - There were no significant ADS-induced errors.
 - Test control procedures worked well during testing with centralized test control exercised from the CCF.
- cannot communicate directly in a common language. They can be a major source of both errors and processing delays. Better direct user control of the content of the data and network communications is needed.
- Common ADS-related hardware and software is needed. In the LSP, it was difficult to get the ADS network to behave in a uniform fashion due to the many different types of interface hardware, communications equipment (routers), and interface software versions.
 - Latency variations were significant. Processing delays were the primary culprit here.
 - Time sources must be synchronized off the same time source and then must be validated at each test site prior to project operations to ensure accurate, synchronized time is precisely recorded at each test site.
 - Special test equipment is needed for check-out and verification of the ADS architecture. Without this equipment, trial and error becomes the norm when (not if) problems crop up.

System Integration Test Lessons Learned

LSP Infrastructure Lessons Learned

LSP Lessons Learned

LSP lessons learned are documented in much detail in JADS LSP Final Report (Ref. 10) and are categorized in the general domains of technical and infrastructure lessons learned. What follows are some of the highlights.

- The requirements for an ADS test must be clearly defined early in the test planning phase. This includes user requirements, support agency's stated actions, and operations security requirements. Planning and coordination details will be much more involved than in a traditional, non-ADS test.

LSP Technical Lessons Learned

- Accurate coordinate transformations are necessary. They must be verified and validated at each site and then revalidated during end-to-end testing as early as possible in the test phase.

- Get "system under test" experts involved from the beginning.

- Quantitative validation has limitations. JADS intent was to quantitatively verify missile simulation performance against live fire data. However, as only one live fly event was available to support the process, a modified approach including both quantitative and qualitative methods was used, and successfully identified invalid results.

- Test communications requirements must be addressed early in the test planning phase. This is necessary to ensure effective communications during the test. Also, a linked test should have multiple (more than two) communications nets with easy, selectable access to all the nets from multiple locations within the site. Finally, the capability for secure video teleconferencing pays big dividends during planning, coordination, and post-test debriefs.

- Network interface units (NIUs) need improvement. NIUs are necessary if two nodes

- A stepped build-up approach should be used. First, a systematic check-out of the stand-alone simulators (live, virtual or constructive) is needed. Next, direct (non-DIS) links should be used during test build-up. Finally, structured

testing of the network must be performed prior to, and independent of, the linked testing times and the simulation laboratories to validate transmission/reception rates, bandwidth utilization, latency, data transmission and reception, etc., prior to commencing project test periods.

- Linking of facilities using ADS can require significant facility interface hardware and software development. ADS implementation is not "plug and play," at least for some time.

- Local (on-site) test monitoring/control should be used prior to remote test monitoring/control.

- Tight control of the aircrew is not desirable. Give them the critical parameters and switchology to meet the test objectives and allow them to make tactical decisions, fly the "aircraft," operate the weapon system, etc.

- Additional time is needed before the beginning and after the end of each testing period. One hour is recommended for set-up, and two hours at the end for data logging, data archiving, data transfer, and laboratory reclassification.

- Briefings are needed before and after each mission.

- Effective data management is needed, as ADS can generate mountains of data. A comprehensive plan will clearly identify the data to be collected at each site, on-site processing of the data, and data to be transferred to the analysis center.

- Adequate time must be allowed for data analysis between test events. Analysis procedures should be rehearsed to better understand the amount of time needed for this analysis.

- Configuration control is essential. This one obvious area was one of great challenge considering the many sites involved and the multiple uses of each site.

LFP Lessons Learned

LFP lessons learned are documented in much detail in JADS LSP Final Report (Ref. 11) and are also categorized in the general domains of

technical and infrastructure lessons learned. Some of the highlights are listed below.

LFP Technical Lessons Learned

- As in the LSP, a major lesson learned is that stand-alone simulation facilities (for live, virtual or constructive entities) can require significant modifications before effective linking is possible.

- Additionally, linking may require special purpose interfaces so as to accept inputs in real time. Development of such units must be factored into test planning.

- Key interfaces need realistic integration testing. Replaying data from a recorded mission worked well in most cases (and was most cost effective); however, some integration testing required a live mission.

- Early definition of network requirements was very advantageous. This was a major lesson from LSP that JADS took advantage of.

LFP Instrumentation Lessons Learned

- Changes and upgrades to aircraft instrumentation delayed development. Specially instrumented aircraft were required to support the LFP flights. Due to the small number of such aircraft, the LFP schedule was very sensitive to periodic aircraft phase inspections, software upgrades, and higher priority missions.

- Merging several TSPI sources was advantageous. Real-time aircraft inertial navigation system (INS) and global positioning satellite (GPS) data were combined to calculate more accurate kinematic estimates. When combined with the ground radars, solutions of one to three meters in position and one meter per second in velocity were achieved.

- A strong program manager or system integrator is needed to oversee facility development, due to the difficulty in coordinating several diverse facilities to successfully integrate an ADS-linked configuration.

- Use risk reduction tests for integration. A

building block approach was used successfully to check out interfaces at the lowest level, then one or two resources at a time were added to integrate the linked configuration. These risk reduction tests were also useful for developing analytical tools.

- Several subnetworks should be used for voice communications. Three voice communications networks were needed to support more than 30 people at various locations, and a fourth network could have further aided decision making.

- Two-dimensional displays were needed at each node; they greatly enhanced the situational awareness of the participants.

- Existing range procedures had to be modified for ADS. The existing test procedures were only written for individual facilities, so a new combined checklist was created for ADS applications.

- Laboratory replays served as an excellent method of test rehearsal.

Other Topics for Consideration

Threat Simulator Linking Activities (TSLA) Study (Ref. 12)

TSLA is a study chartered by the U.S. DoD's CROSSBOW Committee and directed by the JADS JTF. The TSLA study provides an ADS Capabilities Assessment Report which describes the utility of ADS in the context of the evolutionary acquisition process interwoven with T&E. At each phase of the acquisition process, the conventional and ADS methodologies are applied. For each phase, the necessary test facilities are delineated and the differences in test capabilities noted. Test facility requirements are addressed for SPJs, stand-off jammers, and integrated avionics. As the test facility requirements are reviewed, any improvements needed to meet the requirements of the electronic combat test process are noted. Some of these improvements are needed without regard for ADS. In other cases, the improvements are needed only to support ADS. Comparisons of capabilities, with and without

ADS, are discussed. General assessments of the cost impact of ADS are also discussed.

Requirements for and the impact of latency are also discussed. Latency will be present. Depending on the network topology, physical communication infrastructure, and network management methods, it may be possible to achieve a tolerable latency for most applications. Latency remains the greatest technological risk to the successful use of ADS in EW T&E.

Considerations for the T&E Professional

Although JADS still has another year of ADS testing ahead of it, there are several overall considerations which have become evident. What follows are some highlights, as recently briefed to JADS Flag Officer Steering Committee (Ref. 13), and adopted into a pamphlet entitled "Emerging Findings from JADS."

- ADS allows one to link live, virtual, and constructive players based on need. ADS does not mean linking together several constructive simulations to make a bigger, more complex model. Rather, it means blending live, virtual and constructive players to give the user the right mix of fidelity and realism to meet specific needs.

- Distribution is not a function of distance. Latency is a function of processing and transmission, and processing latency dominates. Transmission latencies are predictable and relatively well behaved. Processing latencies can be problematic, though, and require a thorough understanding of the individual sites and the ADS architecture. This holds true whether the network covers a continent or multiple nodes at a single location.

- Validating against live data is problematic. Problems include the quality of the live data and the lack of data availability.

- Data collection is different from traditional T&E and training. Generally speaking, an ADS environment is easier to instrument than the traditional live test environment and provides

more trials per unit of time. The end result is that analysts can get inundated with data. In addition, ADS testing requires additional data to be collected on the performance of the networks linking your sites.

- ADS cost benefits are best realized over the entire system life cycle. JADS has performed some cost benefit analyses comparing traditional test approaches to ones utilizing ADS. In many cases, it appears as if ADS could save time and money (as well as allowing a more rigorous test) in just the test phase of a development program. However, the full benefits of using ADS would be realized over all the phases of the acquisition cycle, from requirements development to training and sustainment. This supports the concepts advocated in both simulation based acquisition (SBA) and Simulation, Testing and Evaluation Program (STEP).

- ADS allows one to test "differently." Adding ADS to a traditional test approach provides only a fraction of the value ADS can bring to bear. To realize the full capabilities of this enabling technology, one will construct a test event fundamentally differently than its traditional forefather.

- To a certain extent, latency is manageable. The ADS architectural design is the most determining factor of latency. The tester must approach network design from a requirements viewpoint. Based on what the tester is trying to accomplish, an architecture can usually be designed which balances the types of participating assets, fidelity requirements, and tolerable latency.

- The effect of latency is dependent on the players involved. Latency is a factor when the tester is trying to generate closed-loop interactions. Again, the tester must approach the test from a requirements viewpoint in determining whether an ADS architecture can provide the interactions needed for the test event.

Conclusions

JADS has been chartered to determine the truth as to where ADS is, or is not, a feasible tool for T&E. JADS JT&E testing is well underway, and the early evidence is that ADS can bring many benefits to the table. However, one must be fully aware of the inherent limitations of the technology. Also, one would be well advised to learn from those who have practical experience in using ADS in the T&E arena. Distributed simulation is certainly not a panacea that will solve all of the problems and meet all of the requirements. However, it does appear to be a powerful tool, if used appropriately and intelligently, and should be considered in balance with other methodologies when developing a T&E program.

References

1. Smith et al., "Program Test Plan," JADS JT&E, 1996, p. 1-1.
2. OSD/DTSE&E Memorandum, "Charter for the Joint Advanced Distributed Simulation," 3 October 1994.
3. OSD/DTSE&E Memorandum, "Amendment to the Charter for the Joint Advanced Distributed Simulation (JADS) Joint Test and Evaluation (JT&E) Program," 23 August 1996.
4. McKee, Draft "Report on the Utility of Advanced Distributed Simulation for Precision Guided Munitions Testing," JADS JT&E, 8 May 1998, pp. 2,5, and 6.
5. Smith et al., "Program Test Plan," JADS JT&E, 1996, p. 3-32.
6. Smith et al., "Electronic Warfare Test Analysis Plan for Assessment (APA)," JADS JT&E, May 1996, p. 2-14.
7. *ibid.*, p. 2-26.
8. McKee, Draft "Report on the Utility of Advanced Distributed Simulation for Precision Guided Munitions Testing," JADS JT&E, 8 May 1998, pp. 3 and 4.
9. *ibid.*, p. 6.
10. Smith et al., "System Integration Test Linked Simulators Phase Final Report," JADS JT&E, July 1997, pp. 5-1 - 5-7.
11. Sturgeon and McKee, "System Integration Test Live Fly Phase Final Report," March 1998, pp. 5-1 - 5-8.
12. McDougal et al., "Threat Simulator Linking Activities (TSLA) Study ADS Capabilities Assessment," Georgia Technical Research Institute, pp. 2-3.
13. JADS JT&E Briefing to the JADS Flag Officer Steering Committee, 25 March 1998, as adapted from JADS JT&E pamphlet, "Emerging Findings from JADS." (Undated).

Acronyms

Following are acronyms found in this paper's figures and not defined in the body of the paper.

Figure 1

A/C - Aircraft
IR - Infrared
MSL - Missile
SMS - Stores Management System
TGT - Target

Figure 2

AASI - Aircraft Avionics Simulation Interface
ECM - Electronic Countermeasures
RDL - Rear Data Link
UMB - Umbilical
TM - Telemetry

Figure 3

ACE - Analysis and Control Element
ASAS - All-Source Analysis System
ATACMS - Army Tactical Missile System
DOCC - Deep Operation Coordination Center
FDC - Fire Direction System
FSE - Fire Support Element
GSM - Ground Station Module
LOS - Line of Sight
OK - Oklahoma
SATCOM - Satellite Communications
SCDL - Surveillance Control Data Link
TRAC - U.S. Army Training and Doctrine Command Analysis Center
WSMR - White Sands Missile Range

Figure 4

ECM - Electronic Countermeasures
IADS - Integrated Air Defense System
RF - Radio Frequency
TECH - Technique

Figure 5

FY - Fiscal Year
Qtr - Quarter

**British and United States Participation in a
Demonstration of GPS Range Instrumentation**
Mr W Ellis, RAJPO, Mr N Raimondo, TASC, USA
and Mr P Travis, British Aerospace Defence Ltd, UK

BRITISH AND UNITED STATES PARTICIPATION IN A DEMONSTRATION OF GPS RANGE INSTRUMENTATION

William Ellis
RAJPO
Peter Travis
BAe
Nat Raimondo
TASC

ABSTRACT

The US DoD has developed a GPS-based TSPI system for use on major T&E DoD ranges. BAe Flight Test Department is purchasing a similar system. BAe desired to have a demonstration of the DoD system. The two organizations agreed to conduct this demonstration in the February and March 1996 time period. The demonstration took place at the British Aerospace Military Aircraft Division, Warton Flight Test Center, Lancashire, England. This paper describes the assets used for the demonstration and the results of the demonstration.

INTRODUCTION

The British Ministry of Defense (MoD) and the US Department of Defense (DoD) established a Foreign Military Sales (FMS) case for the purpose of demonstrating a DoD GPS-based instrumentation system in the United Kingdom (UK). The tri-service Range Applications Joint Program Office (RAJPO) is responsible for developing and delivering GPS-based Time, Space, Positioning Information (TSPI) assets for use on the major DoD test and evaluation (T&E) ranges. The RAJPO was responsible for conducting the demonstration.

This instrumentation is for use on high, medium and low dynamic aircraft, ships, and land vehicles. Reference A describes the details of the system and provides a description of the accuracy validation tests that took place at Eglin Air Force Base, FL.

The demonstration was conducted from the Warton Flight Test Center of the British Aerospace (BAe) Military Aircraft Division. The base station equipment was located at Warton, while missions were flown over the local area, the Irish Sea, and the Directorate of Test and Evaluation Organization (DTEO) Aberporth range facility.

The Warton facility has over 50 years of successful experience in the flight testing of modern fast jet aircraft ranging from the Canberra to the current EuroFighter. The facility has a complete set of test mission support and analysis facilities.

BAe has purchased a variant of the RAJPO system. They will receive the system later this year. It will be one of a number of instrumented packages used for testing the weapons system for the EuroFighter aircraft. The GPS instrumentation will be installed on as many as four chase Tornado aircraft tracked by the sensors of the EuroFighter. The analysts will be able to compare the sensor-derived positions to the GPS-derived TSPI positions of the target aircraft.

THE DEMONSTRATION SYSTEM

The key elements of the RAJPO system are an integrated GPS P(Y) Code Receiver, Inertial Reference Unit (IRU), and the Data Link System (DLS). The GPS receiver provides continuous and precise positioning data. The IRU aids the dead reckoning process if GPS signal processing is interrupted. DLS is a communication and networking system, designed by the RAJPO, for the real-time collection of GPS TSPI and platform data. Figure 1 is an overview of the system.

The TSPI and communication instrumentation assets do not interfere with the equipment under test. As an example, when in use on high performance fighter aircraft, the equipment mounts in a 5 inch diameter Sidewinder missile pod shell. The pod connects to any AIM-9 capable aircraft. The pod uses standard power available at the AIM-9 station. The DLS transmits the TSPI message to the base station for real-time analysis of the test mission. To support post-mission reconstruction, a solid-state memory system mounted in the pod records the measured TSPI.

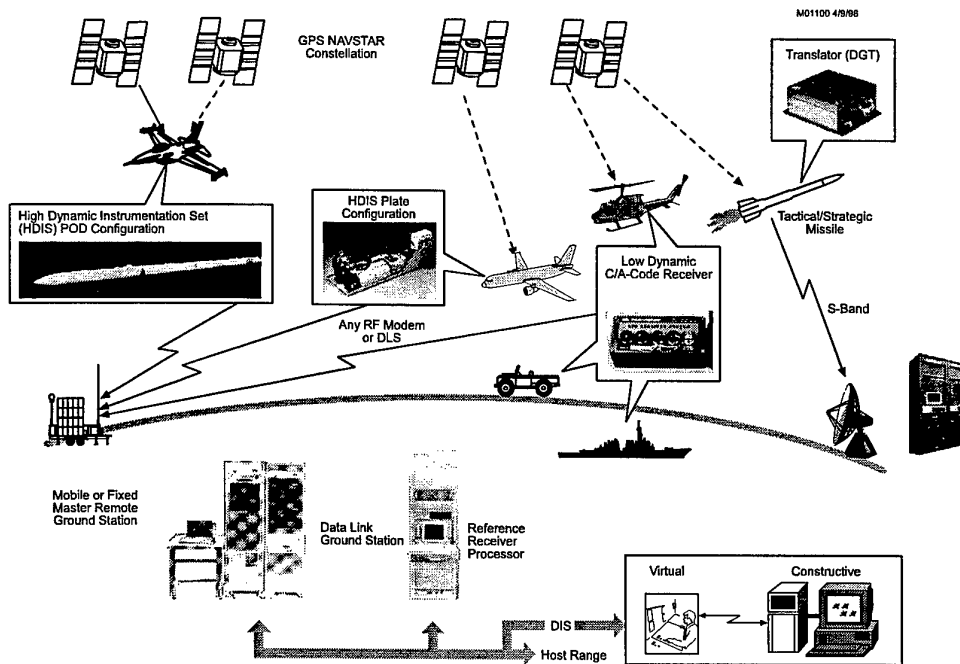

Figure 1. RAJPO GPS Receiver-Based System Overview

The recorded TSPI message is the same message that is transmitted to the base station by the DLS. The DLS processor subsystem records the mission data, and passes this data to the range data analysis and display system.

To minimize multipath effects, the data link antenna in the pod focuses most of the energy forward, attempting to reduce the energy aft and to the sides, where multipath reflections can degrade the direct signal. The GPS antenna is a dual element antenna, one element facing upward, while the other faces downward. The receiver samples these antennas at a four millisecond rate. The receiver apports the energy from each of the antennas based on the energy level in each of the antennas and the orientation of the aircraft.

The ground equipment consists of a Data Link Controller and Processor subsystem (DLC/P), a Data Link Transceiver (DLT), a GPS Reference Receiver/Processor (RR/P), and an antenna subsystem. The base station equipment establishes the network protocols, assigns the frequency of operation, assigns the time slots for reporting of each participant, and records all of the mission TSPI data.

The GPS RR develops the differential GPS corrections and passes these corrections to the communication system for transmittal to the exercise participants. Alternatively, the GPS measurements from the participant receivers are

transmitted to the RR/P for the post-mission application of the differential corrections. Included in the down-linked message are the IRU measurements. The RR/P processor combines the differentially corrected GPS measurements and IRU measurements. These measurements are processed in the same Kalman filter that is part of the GPS receiver in the participant platform.

Tests conducted at Eglin Air Force Base (AFB) demonstrate that the accuracy is essentially the same when either the participant platform or the base station applies the differential GPS corrections. The decision whether to apply the corrections in the participant receivers or at the base station is an operational consideration.

PRE DEMONSTRATION ACTIVITIES

Two RAJPO instrumentation pods were made available for the demonstration. The base station equipment was installed in an interim trailer, as shown in Figure 2. Figure 3 shows the interior of the van and a portion of the equipment installed. It is to be noted that for future utilization, the base station equipment is being installed permanently in a 40-foot trailer.

The system provided for the demonstration is an early version of the RAJPO system. Its performance has been validated on the Eglin AFB test range. The RAJPO system available today takes advantage of newer computers, and fits into one 19-inch rack.



Figure 2. Interim Trailer, Exterior View

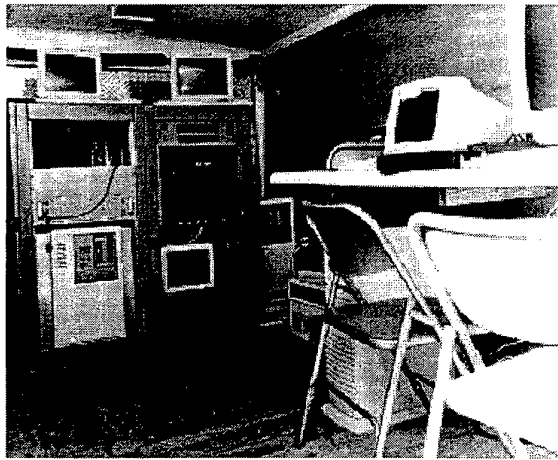

Figure 3. Interim Trailer, Interior View

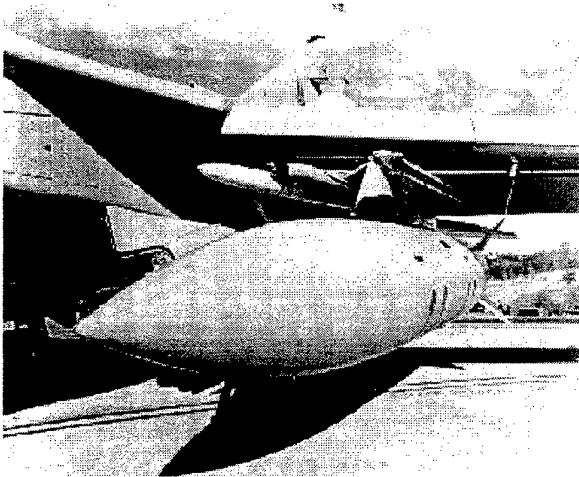

Figure 4. AS011 Tornado Aircraft

The equipment was shipped from Eglin AFB to the Royal Air Force (RAF) base located at Mildenhall. It was driven to the Warton site. The initial activities involved verification that the equipment was operational, and a check of the weight and balances to ensure compliance with the Interface Control Document (ICD) data. The pods were to fly on AS011, a single stick version of a Tornado Air Defense Variant (ADV), and on AT001, a trainer version of the ADV Tornado aircraft. Electromagnetic Compatibility (EMC) tests took place satisfactorily on AS011.

The base station data link antenna was installed on a tower that was approximately 10.6 meters above the ground. Normally, the base station uses a volute antenna that provides coverage of 360 degrees of azimuth and approximately 200 degrees of elevation. This antenna was not available for the demonstration; thus, we used a blade antenna that focused most of the energy upward. Although this antenna is not optimal, all agreed that it would suffice for the demonstration. We would expect the data link performance to suffer somewhat, but not enough to seriously affect the demonstration. It is our understanding that when BAe installs the system they have purchased, they will locate the DLS antenna at a higher location than the 10.6 meter tower used for the demonstration.

DEMONSTRATION FLIGHTS

The initial flight took place on 28 February 1996 with aircraft AS011 as shown in Figure 4.

As shown in Figure 5, we made the test as "unfriendly" as possible by mounting the pod to the inboard stub of the inboard pylon, nearest the fuselage and inboard to a 2250 liter fuel tank. This location would create the highest possibility of signal blockage between the pod antenna and the satellites, and between the pod antenna and the base station.

The demonstration was to take place over the Irish Sea, west of the Warton site complex. Prior to initiating the demonstration, there was a commitment for the aircraft to travel to the DTEO range at Aberporth, approximately 160 kilometers to the South of Warton. We decided to evaluate the performance of the system during this activity.

The transmitted power from the transceiver in the pod and the normal antennas used in the pod and base station, theoretically, limits reliable operation up to distances of 115 kilometers. In operation, we typically observe reliable data link operation on DoD ranges at distances of 250 kilometers between

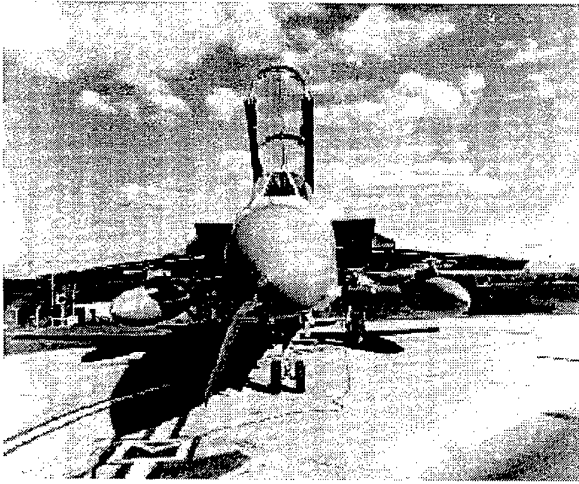

Figure 5. AS011 Aircraft with RAJPO Pod at the Inboard Station

participants and the ground station. As previously described, we did not expect the antenna used at the base station to limit performance, but we could not be sure until the demonstration took place.

The data link performed competently, and we did receive valid TSPI data during the two hours the aircraft was at Aberporth. While at Aberporth, the aircraft did a number of maneuvers. When the pod was between the fuselage and the base station antenna, message integrity exceeded 95%. When the fuselage was between the pod and the base station antenna, message integrity was slightly better than 65%, a number that is adequate for many applications.

However, to assure message integrity in any platform orientation, and at long distances between the aircraft and base station, RAJPO can supply remote data link transceiver stations. The remote station will relay the received aircraft messages to the base station. To assure adequate coverage during a test mission, many of these remote stations are usable on a range. The base station will combine messages received directly from the participating aircraft with the messages relayed from all of the remote sites, further enhancing the message reliability of the system.

The remote station includes a DLS transceiver, an interface unit, power conditioner, and an optional rubidium frequency standard. Since they are often exposed to the elements, the assemblies are in an environmentally secure enclosure. These remote transceiver units measure approximately 483 x 711 x 610 mm, and are easily relocated. The remote stations are often located in areas that are not easily accessible. Hence, an additional concern is power to operate these units. Some of the US

ranges operate these remote stations with solar power subsystems.

A remote transceiver station positioned to the south of Aberporth would have maintained the message integrity of 95%, regardless of aircraft orientation. The RAJPO specification states a message reliability of 99% when the participant pod can maintain line of sight to two ground stations.

RAJPO provides software to determine the optimal location of data link transceiver sites for any defined mission and topography. Using this software, the Range Manager can "fly" the aircraft through the range to determine the expected data link and GPS performance, and then locate remote site(s) for optimal coverage during a mission.

When the aircraft completed its mission over the Aberporth range, it traveled to the demonstration area over the Irish Sea, approximately 50 kilometers from the Warton base station. The aircraft flew a variety of relatively low dynamic flight profiles, including race track turns and 'S' turns. We can expect the maximum amount of multipath when flying over sea water at low altitudes. However, the aircraft flew at an altitude of approximately 160 meters over the Irish Sea without any degradation of message integrity or TSPI accuracy.

During all of the demonstration period over the Irish Sea, data link integrity was in excess of 95%, and the TSPI data was of fine quality in all aircraft orientations. It did not matter whether the pod antenna(s) was facing the base station, or if the pod antenna(s) line of sight to the base station was blocked by the aircraft fuselage or fuel tank.

A two pod, two aircraft demonstration took place on 1 March. To provide as much diversity as possible to the demonstration, one pod was located on the left wing of AS011 and the other on the right wing of AT001. Once again, the pods were connected to the inboard stub of the inboard pylon of each aircraft. As before, the aircraft flew to the Aberporth range prior to returning to the demonstration area over the Irish Sea. We were able to receive reliable (94.5%) TSPI data from the two aircraft while they were at the Aberporth range, and on their return to the demonstration area over the Irish Sea. The reliable TSPI data resulting from this activity continues to demonstrate the high performance of the RAJPO system.

Using the two aircraft participating in this exercise, we were able to demonstrate the automatic relay capability of the DLS, i.e., the DLT continuously seeks the most efficient routing for a participant message back to the base station. This automatic routing feature of the RAJPO system uses other

aircraft, ground based remote DLS sites, as relay nodes. The DLS will support up to five levels of relay for the transmission of a single message. We were able to successfully demonstrate the aircraft-to-aircraft-to-base station relay capability of the system.

On 4 March the exercise was repeated successfully. On 7 March a final demonstration took place. On this day, we flew one pod on each wing of the AS011 aircraft. The aircraft did not have to travel to Aberporth. We had two hours of successful flying time, repeating the fine performance observed during the previous tests.

CONCLUSION

The demonstration of the performance of the RAJPO system was an unqualified success. The RAJPO assets demonstrated that they can support a wide range of flight test activities. The demonstration allowed BAe to gain valuable information about the installation and use of the variant system they will receive. BAe will install the base station equipment permanently at the Warton ground station Command Center. The master DLS antenna will mount on a tower that is much higher than the location used during the demonstration. A remote DLS transceiver installation site will improve the coverage for anticipated EuroFighter flight testing of the onboard weapon system. Both the master and remote stations will use volute antennas rather than the blade antenna used in the demonstration. These factors should result in a system performance that exceeds that observed during this demonstration.

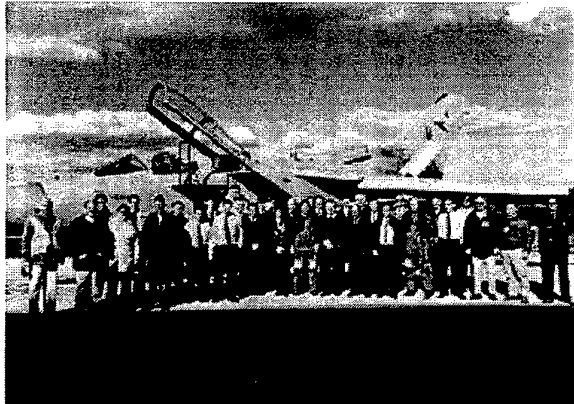

Figure 6. The Team Bringing the Success

Figure 6 shows the entire team that supported this demonstration activity. Only as a result of the total support of all the members of the team were we able to successfully execute the demonstration of the system.

REFERENCES

A. Pace, Richard, et al. "The Pioneering of GPS-Based Range Programs", Proceedings of the European Test and Telemetry Conference, 1995.

**The Evolution of Optical Tracking Facilities Within
UK Test and Evaluation Ranges**
Mr J Lees, Defence Evaluation and Research Agency, UK

THE EVOLUTION OF OPTICAL TRACKING FACILITIES WITHIN UK TEST AND EVALUATION RANGES

Jonathan Lees
Optical Instrumentation
DERA Aberporth
United Kingdom

Abstract

The need to optically track fast moving targets with great accuracy has always been a prime objective of Test and Evaluation Ranges.

During the Second World War the kinematic theodolite, commonly known as the kinetheodolite was developed for this purpose and although many improvements have been made since then, the principles of operation have not significantly changed.

As defence technology advanced, new, more challenging demands were placed upon optical tracking instrumentation. Targets became more dynamic and complex and customers soon started calling for greater degrees of accuracy, faster image frame rates and improved image quality.

These new requirements eventually prompted a feasibility study to investigate a replacement for the kinetheodolite and this in turn led to the development of the modern day Electro-Optical Tracking Instrument (EOTI).

These mobile instruments are capable of automatically tracking small, very fast moving objects at increased ranges. They have excellent angular resolutions and their multi-sensor platforms are capable of high rates of angular acceleration and the video frame rates necessary to meet the demands of present and future customer requirements.

This paper presents a historical case study of the changes in optical tracking within Ranges concentrating upon the evolution of the early kinetheodolite into the modern day and future EOTI.

Introduction

Why do we need Test Ranges? The answer to this question is we need to prove operational capability of weapon systems, provide empirical evaluation of performance in terms of stated design objectives and to provide information that may allow customers to improve the performance envelopes of their systems.

Generally for tracking instruments, this means determination of trajectory, behaviour and performance of in-flight projectiles whether they be shells, missiles, flares, bombs, sonar-buoys or aircraft.

Over the years, measurement techniques have needed to advance in order to cope with the demands placed upon them by rapidly developing weapon systems.

Prior to the Second World War, the only ground based metric techniques utilised to precisely determine the position of spatial objects were simple bomb scoring theodolite systems.

In this system, a pair of manually directed theodolites sited for good triangulation geometry followed the target with post-mission target information being derived from recorded film records.

In America, the Akely Cinetheodolite was developed by the Mitchell Camera Corporation while in Germany, Askania-Werke produced the Kinetheodolite.

The former employing a cine film, intermittent movement and the latter a pulse film movement while the Askania had the superior performance characteristics.

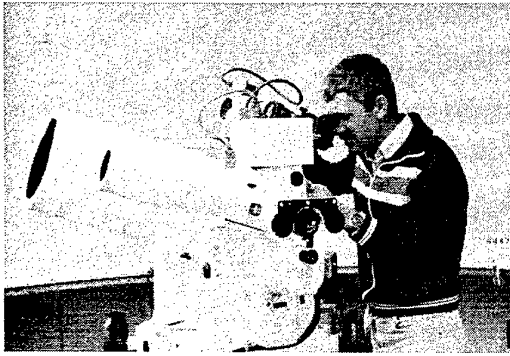

Fig 1. A modified Askania kinetheodolite.

With the advent of Radar during the Second World War, automatic tracking of spatial objects became widely adapted for Weapon Ranges work. It provided readily available target positional data in visible and often non-visible conditions, but the accuracy was in the region of ten times lower than that achievable using a kinetheodolite system.

Tracking radars were used during the early missile development era to slave direct servo platforms, usually modified anti-aircraft gun mounts carrying high-speed cine cameras. This technique enabled much higher spatial positional accuracies to be derived.

The Early Years

A variety of optical instrumentation has been developed for target tracking over many years. Some of the more common types are:

- i) Kinetheodolites
- ii) Ballistic cameras
- iii) High speed tracking cameras
- iv) Automatic TV trackers

Soon after the end of the Second World War, most western Missile Test Ranges acquired numbers of wartime German Askania kinetheodolites, and these with a certain amount of modification have supplied an excellent service for many years. However, they had their disadvantages.

These limitations which in turn prompted major developments may be classed under four headings:

- i) Accuracy
- ii) Data rate
- iii) Target acquisition difficulties
- iv) Data availability time

The generally accepted accuracy of an analogue Askania theodolite in an ideal two instrument tracking system is about 15 seconds of arc rms giving positional accuracies in the region of 0.6 m at a range of 1500 m increasing to 12 m at a range of 20 Km.

While this was initially acceptable for short-range work, pressure for improved accuracies grew with the extra precision required when measuring parameters such as position, velocity, acceleration, pitch, roll, yaw and miss-distance.

Another, very important reason for having more precise optical systems was the need to offer a measurement standard to allow other instrumentation to assess and maintain performance.

These requirements led directly to developments such as the Askania GIGAS and Contraves Electro-Optical Tracker which offered individual instrument accuracies in the region of 0.0014 degrees rms.

The demand for more precise velocity and acceleration measurements also led to required increases in exposure rates and in some cases mechanisms were enhanced to achieve 30 frames / second.

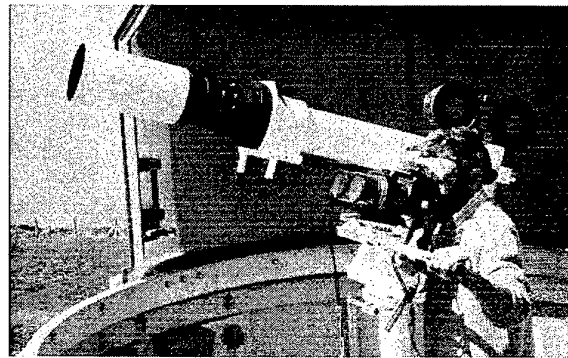

Fig 2. High speed tracking camera

Although increased frame rates offered greater time based resolution, there was a disadvantage in increased amounts of data to collect, process

and analyse, drastically increasing the data availability time.

A major problem remained with kinetheodolites still requiring an operator in the servo loop in order to acquire and track the target. It is known to be difficult to acquire targets travelling towards or away from the instrument and difficult to track a manoeuvring, agile target.

Various aids were developed which split broadly into two types, namely acquisition indicators and servo drives.

Both systems accepted data from some independent source and converted this pointing data to a polar form with local origins set at the particular instrument to be aided.

This data could then either be displayed as a deflection in the eyepiece of the operator or used to drive servomotors, pointing the instrument towards the target.

Single operator kinetheodolites also, on occasions suffered complete loss of target track due to erratic operator movements.

An operator without having to change stance or move the feet can normally traverse tracking arcs of up to 25 degrees in azimuth. When greater operator movements occurred, real time data degradation was often the result.

Two-man operation, one directing each axis eased this problem but such instruments tended to be expensive.

With the introduction of smaller, more agile weapons, the demand upon operator performance increased together with the requirement for yet higher accuracies, the need for target attitude information and the regular requirement to track specific physical features of the target. This led to the first developments of auto-tracking platforms and the eventual integration of a video camera into the kinetheodolite

This idea involved an electronic auto-tracking unit accepting video and crudely calculating what it considered to be a target. It then produced error signals to the servomotors in order to keep the target in the centre of the field of view. Another advantage was the video error

could be summed with main scale values to produce real time, high precision pointing data.

Another early development in the automatic optical tracker field was the laser tracker, LIDAR and the American counterpart PATS. These worked well with large, co-operative targets such as aircraft, but many missiles were deemed unsuitable platforms for mounting the necessary large reflectors due to aerodynamic and other problems.

Lasers became very useful as target ranging devices although their eye safety problems prohibited wide spread use. Today, high power pulsed eye-safe lasers are available for integration into any tracking system.

By the early seventies, the disadvantages of then currently available optical and electronic instrumentation was of great concern to UK weapon development contractors. There were new requirements for precision tracking of multiple sub-munitions and rapid data turn around times. Contractors were given tight development time scales and offered incentives to achieve them. This forced Test Ranges to once again reassess their tracking instrumentation.

The Instrumentation Department at RAE Farnborough was tasked to investigate and develop new precision tracking instruments for UK Ranges. The investigation led to two distinct options.

- i) To procure new digital kinetheodolites with integral TV trackers and combine the data produced with radar data into some form of high-speed data bus.
- ii) To develop mobile servo platforms which could carry multiple sensors, optical and electronic. These platforms must also be capable of working as a single trajectory measurement station and / or be incorporated into a Range data bus.

The latter option was favoured and the basic specifications were agreed to be:

- i) a single station trajectory measuring system
- ii) tracking accuracies to be better than 50 micro-radians 1σ in angle and 1 metre in range.
- iii) data rate selectable up to a maximum of 100 samples / second
- iv) with a full five sensor payload, must be capable of angular slew and acceleration rates of $100^\circ/\text{second}$ and $100^\circ/\text{second}^2$ respectively
- v) compact onboard recording of all sensor images, angular data, range, status and timing information
- vi) built in self calibration system
- vii) individual systems must be completely mobile
- viii) real-time data output interface for a standard data-bus
- ix) capable of being operated and maintained by two operators

IT6, Farnborough procured a Swedish, Saab-Scania TLT-510 without its laser range-finder for evaluation and subsequent development into a prototype Electro-Optical Tracking Instrument (EOTI).

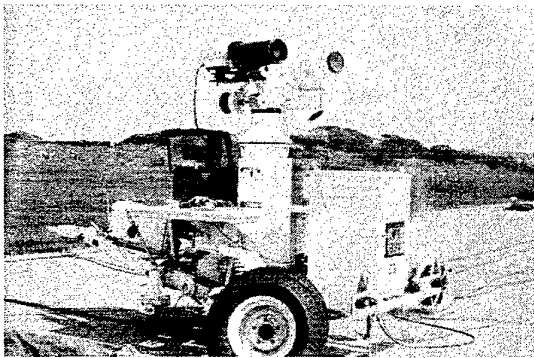

Fig 3. The Saab-Scania TLT-510

During the TLT-510 manufacturing period, IT6 department carried out a comparative study of millimetric radar and laser ranging devices. From this study, it became clear that in order to achieve a range accuracy of 0.5 metres at extended ranges, both methods required some form of co-operative device fitted to the target. The only laser then capable of generating sufficient pulse power for long-range tracking

was the Nd Yag, a non-eye safe laser operating at 1.06 micrometers wavelength.

Due to safety and other problems associated with the laser, a millimetric, Range Only Radar (ROR) was developed with the help of RRE Malvern with the prototype production contract being awarded to MCCS of Frimley.

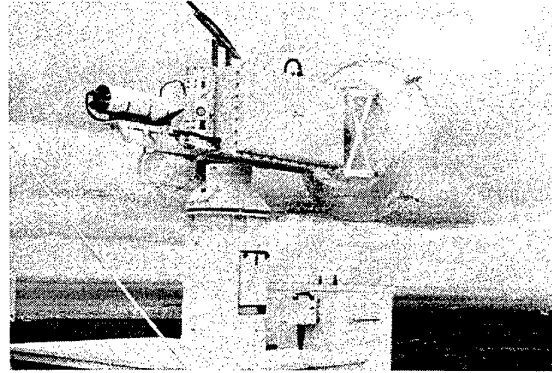

Fig 4. The TLT-510 with prototype radar

This prototype ROR was mechanically integrated into the TLT-150 and the complete system mounted on a modified Rapier trailer for the purpose of field tests.

The prototype EOTI was then tested for accuracy using drone targets fitted with millimetric Lunarberg lenses. Tests were carried out at the Aberporth Range and range accuracies of 0.3 metres were consistently achieved against Jindivik targets out to Ranges of 20 Km.

Three years of EOTI testing as a single station system followed with acquisition assistance derived from tracking radar via microwave links. These tests took place at the three RAE test Ranges of Aberporth, Larkhill and West Freugh against a variety of targets including aircraft, bombs and land, air and sea launched missiles. Accuracy performance and data rates all met the set requirements, but the narrow beam width of the optics introduced major target acquisition problems, especially against high speed, dynamic targets.

Various acquisition options were then studied including; zoom optics, target prediction and moving target detection. Eventually, a combination of all three techniques proposed by British Aerospace, Bracknell offered the greatest promise.

In 1984, a Ranges committee agreed the final EOTI technical specification and production tenders were requested from industry, worldwide.

Bids were received from eight firms, three British, three French, one Swiss and one American. At the same time, MCCS were awarded a production contract for 12 ROR's. The tenders called for seven general-purpose, four high precision and two special EOTI's that were to be dedicated to and paid for by one project office.

Contraves Goerz offered thirteen identical servo platforms with optics and electronics to satisfy all three types of EOTI. British Aerospace, Bracknell offered a similar solution but employing German MBB platforms, Zeiss optics and British Aerospace control electronics.

Contraves offered eleven SkyTrack instruments and two of Goerz's servo platforms for the special requirement.

After careful consideration of all the options, British Aerospace, in partnership with MBB of Bremen, FRG were awarded the contract for the EOTI's and MCCS of Frimley were awarded the contract to manufacture the Range Only Radars which were to be integrated into the EOTI's.

Present day technologies

The EOTI

The present day EOTI's are high precision, auto-tracking instruments capable of carrying a large payload of various sensors, including

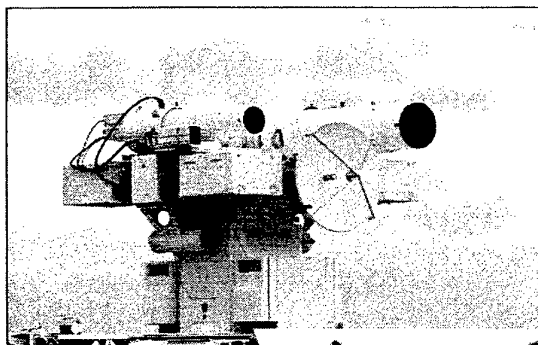

Fig 5. A British Aerospace/MBB EOTI mount

video cameras, Range Only Radar, InfraRed, and High-Speed cameras.

The EOTI supplied by British Aerospace Plymouth and MBB comprises:

- i) The MSP 2000, servo platform fitted with the MCCS Range Only Radar type 282, video Cameras, film cameras and associated optics.
- ii) A British Aerospace TV auto-acquisition and auto tracking system.
- iii) A Control and Record Module (CRM) which also communicates with other Range instrumentation.

The MSP-2000 EOTI servo platform.

The MSP-2000 precision platform is a 'T' mount configuration capable of carrying up to seven sensors at a weight of up to 1000 kg. It has angular velocity and acceleration capabilities of 100°/second and 100°/ second /second respectively. It is carried on a heavy-duty trailer and is operated remotely via a fibre optic link from the CRM. The platform basically comprises a pedestal azimuth unit, elevation unit and a pair of sensor attachment mounts. Both elevation and azimuth shafts are driven by Samarium Cobalt DC torque motors in direct drive configuration. Optical encoders attach directly to the Azimuth and elevation shafts and measure angular position to a resolution of 21 bits (0.00017 degrees).

The trailer with road suspension and rear electronics compartment consists of a rigid central chassis, to which the platform is connected via a three-point fine leveling system.

When in operation, the centre chassis is supported by four adjustable jacks, used for course leveling of the instrument.

During any trial, video information together with target line of sight angles, target range and synchronised time is recorded to videotape. All measurement and status digital information generated by the EOTI is also recorded through

an industrial standard interface to magneto-optical disk ^[1].

A flat-top vehicle carries the Control and Record Module and tows the servo platform trailer. During deployment, the vehicle and the trailer are separated and when not in use, the platform is protected from the elements by a clam-shell type, hydraulically operated cover.

EOTI outline specification

The capabilities of the instrument are summarised below.

Angular velocity	100°/second
Angular acceleration	100°/second /second
Maximum payload	1000kg (balanced)
Tracking lens	0.5m/1.0m/2.0m
Multi-Focal length	f11 at 2m
Tracking accuracy	20 microradians best
Mechanical accuracy	15 microradians best
ROR accuracy (point target) ^[2]	0.5m <10km 0.005% range >10km
ROR range rate measurement accuracy ^[2]	1.5m/s <10km proportionately greater for ranges greater than 10km
ROR PRF ^[2]	8kHz <14km 4kHz >14km, <35km 2 kHz > 35km
ROR Tracking Range ^[2]	Missile typically 10km Aircraft typically 35km

In order to achieve the required dynamic tracking accuracy of worst case 50 microradians or 0.0029 degrees, the instrument needs to be located on a highly stable plinth. It is possible however to deploy an instrument on an un-prepared surface with some degradation in angular accuracy.

EOTI sensors

A wide-angle acquisition camera is provided to assist the operator in acquiring agile targets. Once acquired, the automatic tracking loop is closed via a mechanically shuttered, high resolution video camera and a British Aerospace auto-tracking unit. The main Multi-Focal Lens has selectable fields of view (horizontal) of 1.4°, 0.7° and 0.35° corresponding to focal lengths of 0.5m, 1m and 2 m respectively.

IR sensors and an additional telescope is provided for mating with a high-speed film camera.

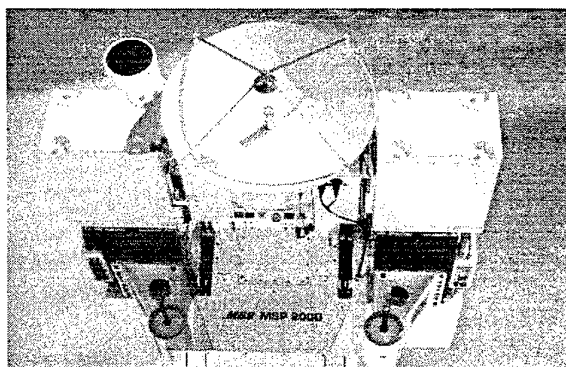

Fig 5. A British Aerospace/MBB EOTI mount

EOTI Control and Record Module (CRM)

The EOTI is controlled remotely by an operator in the Control and Record Module, a transportable cabin based upon an international style shipping container which is compliant with tempest requirements. This cabin is linked to the servo-platform via a multiple fibre-optic cable. The CRM contains the following main components:

- i) EOTI control and display console
- ii) System control and display computers
- iii) Digital and video data recorders
- iv) VDU for post mission analysis
- v) Interface computer

EOTI video image auto-tracker

At the heart of the auto-tracking loop lies the British Aerospace auto-tracking unit which is capable of automatically acquiring up to 5 moving targets appearing within the tracking video camera field of view and subsequently auto-tracking any two of these simultaneously. Using centroid, correlator or other tracking techniques, target-to-sensor boresight errors are accurately estimated for each target. For one selected target, these errors are used to drive the servo platform via a closed loop to align the sensor boresight with the target.

EOTI operation

On fully instrumented test Ranges, target acquisition assistance is made available from any of the following systems; surveillance radar, tracking radar or other EOTI's.

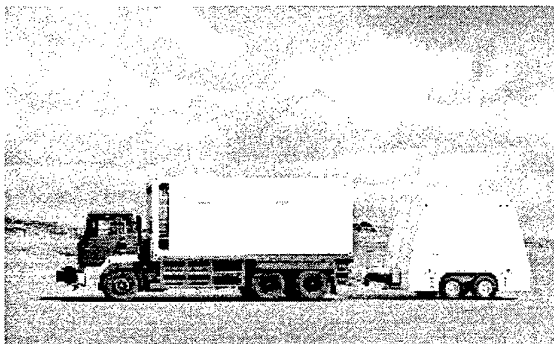

Fig 6. EOTI lorry, CRM and trailer ready for deployment.

Other optical instrumentation

Other tracking and non-tracking optical instrumentation still used on DERA Ranges include:

- i) Pin registered 16mm Photosonic and NAC high-speed cameras capable of operating at speeds up to 1000 frames/second.
- ii) Steerable 35mm tracking used for behavioral analysis.
- iii) Fixed 35mm launcher cameras running at a phase locked 100 frames/second.

- iv) Fixed 70mm cameras running at 100 frames/second generally used for high definition work.
- v) Vinten 10/21 type tracking cameras. Generally mounted on other instrumentation such as EOTI's.

The present day kinetheodolite

There are in the order of 24 functional kinetheodolites still providing a valuable function for DERA Ranges and are mainly used for short-range tracking trials. As stated previously, they have remained relatively unchanged over the years with some being modified more than others. The main enhancements include 10 frame / second shutter mechanisms, the integration of the acquisition aid systems, electronic flash type azimuth and elevation exposure and various lens modifications.

To continue using these instruments indefinitely poses many problems associated with high maintenance costs, high film and processing costs and high infrastructure costs. Other factors include a reduction in short range, ground launched firings and a relative increase in long range work.

A combination of these two factors has led to a gradual reduction in the use of kinetheodolites to the extent where today, only 5% of data used for analysis is collected using the kinetheodolite.

It is DERA's intention to begin to phase out kinetheodolites at the end of 1998. This will be made possible by investments into a new Mobile Video Tracking (MVT) system, development of new EOTI sites, effective trials programming and increased campaigning of already mobile instrumentation.

One demand for the kinetheodolite worth mentioning is the interest expressed by various museums in the UK and Europe. A type 42 Askania kinetheodolite will be donated to a museum in Peenemünde. A later type 52 and a HS300 high-speed camera have been donated to another interested museum in Birmingham, UK.

The Future

The need to modernise instrumentation and stay ahead of the game is paramount as new technologies invariably result in enhanced performance at reduced cost leading to greater efficiency and added customer value.

The move towards digital imaging

Photographic film has been used extensively for many years within Test and Evaluation Ranges, it is however expensive in terms of the cost of both materials and processing. Another significant disadvantage is the processing time involved, adding delay to the critical data turn-around time.

Video has now been widely used for a decade or so in gathering optical data and although presently lacking in terms of resolution when compared to photographic mediums, still has much to offer.

The area of digital video is advancing at quite a rate both in terms of resolution and achievable frame rates and can currently be used as a direct replacement for much of the photographic media used on Ranges today. The Optical Instrumentation facility is looking very closely at this technology and its possible applications and associated cost savings.

Mobile Video Tracking system (MVT)

The Mobile Video Tracking (MVT) system is an area of investment that will be instrumental in the eventual phasing out of kinetheodolites. This proposed system, consisting of at least three individual instruments will meet a customer need in terms of the relatively short range tracking of a variety of targets, ranging from dynamic missiles to large cargo drops. The instruments will be flexible in terms of the instrumentation they will carry and they will be highly mobile, transportable using existing Range vehicles.

Although the final specification for this system is not yet finalised, individual instrument angular accuracies will be in the region of 0.01 degrees or better.

Future EOTI's

The EOTI, although a very capable instrument

as it stands, will require enhancement in coming years. The main areas of investment are anticipated to be:

- i) Improved tracking ability achievable through investment in modern, highly configurable auto-tracking techniques. This would allow Improved acquisition of increasingly agile targets and a better chance of success in tracking the unpredictable target.
- ii) Enhanced imaging through the use of new data recording mediums, low noise video components and mastering techniques.
- iii) Improved flexibility in meeting customer requirements through the use of flexible acquisition and tracking lens assemblies.
- iv) Improved radar range through investment in new, low noise front-end amplifiers.

Infra-Red (IR)

IR cameras are essential when tracking is required in poor visibility or when light levels are low. Although Ranges have an IR capability in the form of several far-band IR cameras, the use of near band infra-red has been found to be of great use when observing small, rapidly moving projectiles.

Conclusion

This paper has chartered the evolution of optical tracking instrumentation within British Test Ranges from the simple bomb scoring theodolites to the modern day and future Electro-Optical Tracking Instrument. This development has involved the growth of a variety of technologies such as the early kinetheodolite offering accuracies of typically 0.004 degrees and modified kinetheodolites offering aided acquisition, increased framing rates and improved lens assemblies.

Radar-slaved servo platforms followed with human input being removed from the control loop for the first time. This idea was further developed with the advent of laser and video auto-tracking and auto acquisition systems. Studies in the early 1980's led to the procurement of a SAAB TLT-510 servo-platform which in turn paved the way for the final specification and eventual production of the present day EOTI.

The need to modernise and remain capable of meeting present and future customer requirements remains paramount. Exploring and adopting new technologies is necessary in achieving enhanced performance and invariably results in greater efficiency and added customer value.

Improvements in Optical Instrumentation are very definitely customer orientated with planned EOTI enhancements in the areas of adaptable lens configurations, improved Range Only Radar, improved IR capabilities and enhanced auto-tracking capabilities.

The vision is ultimately to be able to supply the customer with the required high quality results, quickly, first time, every time with minimum preparation and practice.

Demands facing Optical Instrumentation involve observing more complex and dynamic targets, requiring extensive behaviour and trajectory information often for a minimal financial commitment. New, compact and highly Mobile Video Tracking instrumentation is planned, initially taking over the roll of the kinetheodolite, but quickly extending that role in order to maintain and attract new business,

essential in the future success of DERA T&E Ranges.

Acknowledgements

I would like to thank Steve Davies for all his help and direction, Also Christian Andrew for his help in researching this paper.

References

[1] **Optical Detection and Tracking Systems**
Signal Computing Limited
Ref P0265/020

[2] **Marconi Command and Control Systems**
ROR type 282 Technical Specification Paper
MCCS-3089-288

**Validation of Future Gas Turbine Technology by BR700
Core Demonstrator Engine Tests in the Stuttgart
University Altitude Test Facility
Dr M Menrath, Dr K J Schmidt, Mr R Merten,
BMW Rolls-Royce Aero Engines and Prof W Braig,
University of Stuttgart, Germany**

**VALIDATION OF FUTURE GAS TURBINE TECHNOLOGY BY BR700 CORE
DEMONSTRATOR ENGINE TESTS IN THE STUTTGART UNIVERSITY ALTITUDE TEST FACILITY**

Dr. Martin Menrath, Dr. Klaus-J. Schmidt, Ralph Merten
BMW Rolls-Royce Aero Engines
Dahlewitz, Germany

Prof. Dr. Wolfgang Braig
Institut für Luftfahrtantriebe, Universität Stuttgart
Stuttgart, Germany

1.0 Abstract

After the formation of BMW Rolls-Royce in July 1990, the company was concentrated on design, manufacturing and marketing the BR700 engine family, which covers the 12.000 to 22.000 lbs thrust range. The BR710, the first variant of the family, achieved full certification 48 months after programme launch. The BR715, the second variant of the family, will be certified in only 37 months after launching the project. For future civil engines the trend is likely to go down to a 30 months product development cycle. To de-risk the development programmes, strategies must be set in place which allow the introduction of advanced technologies with an acceptable level of risk. Consequently, advanced technology must be build up in separate research and technology acquisition programmes. The validation of the most promising technologies has to take place in a representative engine environment in order to minimise the risk for future applications.

BMW Rolls-Royce therefore decided to use the BR700 core engine as platform for component validation and certification tests at the „Institut für Flugantriebe“ at the University of Stuttgart.

This paper describes the set-up of the Stuttgart ATF for core testing and gives some examples of how the BR710 and BR715 development programmes have been de-risked by using the core vehicle as a mean of technology readiness demonstration. In addition, the strategy is briefly described how to use core testing as a technology demonstration strategy for the 21st century.

2.0 Nomenclature

Abbreviations

A/I, A/O	Analog Input/Output
ARINC	Aeronautical Radio Incorporated
ATF	Altitude Test Facility
CMS	Control and Measurement System
CPU	Central Processing Unit
D/I, D/O	Discrete Input/Output
EEC	Electronic Engine Controller
EPR	Engine Pressure Ratio
FADEC	Full Authority Engine Controller
FAR	Fuel Air Ratio
FC	Facility Controller
FMU	Fuel Metering Unit
HPC	High Pressure Compressor

HPT	High Pressure Turbine
ILA	<i>Institut für Luftfahrtantriebe</i>
MC	Master Controller
NOX	Nitrogen Oxides
SOT	Stator Outlet Temperature
VXI	VME Extended Instrumentation

Symbols

NHRT	Aerodyn. speed high-pressure shaft
N1	Mech. speed low-pressure shaft
N2	Mech. speed high-pressure shaft
P	Total pressure
S	Static pressure
SYN	Synthesised
T	Temperature
t	Time
W	Mass flow
WRTQP	Corrected mass flow
Ø20	T20/288.15 K

Indices

20	Engine inlet
25	Core engine inlet
30	HP compressor exit
42	Downstream valve 42
57	Downstream valve 57
60	Upstream valve 60
90	Test cell
_C	Command value
_D	Demand value
_M	Measured value

3.0 Introduction

With the formation of BMW Rolls-Royce in July 1990, the mission set by the two shareholders BMW AG and Rolls-Royce plc. was to become a leading European engine manufacturer. The company has concentrated, from the beginning, on design, manufacturing and marketing a modern, highly competitive gas turbine engine family, which covers the 12.000 to 22.000 lbs thrust range, Ref. 1. The BR700 engine family is based on a common core concept and different low pressure system configurations to match the aircraft thrust demands from the ultra long-range executive jets and from the regional aircraft market up to a size of 120 seats, Figure 1. With the launch of the engine core in March 1991 the BR700 engine family was introduced into a very highly competitive market to provide a family of engines with best performance, lowest noise

level and exhaust emissions, highest reliability and minimum operational cost.

The BR710, the first variant of the family was launched in September 1992 and has been fully certified in August 1996 for the Gulfstream application, one day ahead of schedule set 48 months earlier. The development time of the BR715 for the Boeing 717, the second variant of the family, was already reduced down to 37 months from project launch to certification. For future civil engines the trend is likely to go down to a 30 months product development cycle to better match the aircraft development time scales. The demand to develop competitive engines with the highest available standard of technology and in parallel to continually reduce the time from project launch to certification, introduces more and more risk to the engine development programmes. Therefore, strategies must be set in place to allow the introduction of advanced technologies in the product concept phase at an acceptable level of risk for the product realisation phase, Figure 2.

Within the product realisation phase, one of the critical milestones is always the first run of a new engine followed by a series of performance/functional tests and the programme usually finishes with a number of critical certification tests, Ref. 2. In the case of BR710 applications the flight test programme was supported with flight worthy engines already in the middle of the BR710 engine development programme before final engine certification. In parallel to the engine tests a high number of laboratory and rig tests on single components and engine modules have been carried out in the component development programme, Figure 3. By shortening the product realisation phase down to 30 months, it becomes obvious that there is more or less no time left for the programme to fix major unforeseen problems. Consequently, advanced technology must be build up in separate research and technology acquisition programmes as shown in Figure 2. The BMW Rolls-Royce strategy for advanced technology acquisition is summarised in Ref. 3. One of the objectives of the programme, which is being promoted by the Federal Ministry of Education, Science, Research and Technology, is to establish a competitive technology base from which core engineering skills can be developed and sustained.

For the most promising technologies the final validation will take place in the form of full scale technology demonstration. In addition to the validation of engine components with test-rigs, this demonstration has to take place in a representative engine environment in order to minimise the risks for future applications/products.

BMW Rolls-Royce therefore decided to use an already existing BR700 core demonstrator engine as platform for component validation and certification tests. At the „Institut für Flugantriebe“ at the University of Stuttgart, a suitable altitude test facility was available and could be adapted to satisfy the specific requirements for core engine testing, Ref. 4.

The main part of the paper describes the set-up of the Stuttgart ATF for core testing and gives some examples of how the BR710 and BR715 development programmes have been benefited respectively and de-risked by using the core vehicle as a means for technology readiness demonstration. In addition, a strategy is briefly described how to use core testing as technology demonstration strategy for the 21st century.

4.0 Objectives of Core Engine Testing

4.1 Core Engine

A 'core engine' comprises of substantially the high pressure components of the engine, a special intake casing and a final nozzle with an adjustable area, Figure 4. In core engine testing, the mechanical and aerothermal integration of the high pressure system is to be replaced by a computer controlled system. This Master Control System co-ordinates the operation of the high pressure spool and the computer controlled facility, which simulates the low pressure system. The core engine can then be operated under steady-state and transient conditions under almost the same conditions as in an engine with a low pressure system.

4.2 Advantages of Core Engine Testing

Compared with entire whole engine tests, core engine testing additionally offers a number of advantages for the validation of the high pressure components over the entire operating range of the engine:

- One significant advantage is the increased cost effectiveness compared with a whole engine test in an ATF. Low pressure components are not required when building the test vehicle. This leads to lower assembly and engine hardware costs. The savings on installation and testing alone amount to approximately 30 %.
- Without a low pressure system it is possible to vary the mechanical rotor speed and the temperatures in the core engine independently. This makes it easier to carry out thermal paint tests and allows to investigate the blade dynamics of the high pressure system in an engine environment at high rotor speeds but at low turbine temperatures.
- Due to the variable nozzle geometry, performance investigations on the high pressure components can be carried out over a wide operating range with no LP system constraints. This supports the optimisation of HP compressor and turbine operating points in the engine operating environment.
- The direct measurement of the core air mass flow increases confidence in "spool derived values". It allows the high pressure turbine to be validated in the same way as a 'hot' turbine rig. The operating points of the combustion chamber can be determined more precisely, especially during altitude reflight tests. Exhaust emission analysis also has a tendency to give better quality results.
- Since the core inlet pressure and temperature can be adjusted independently, it is easier to carry out systematic surveys on the HP compressor and turbine Reynolds Number effects.
- The better accessibility to the high pressure components makes it easier to install and operate

sophisticated instrumentation such as HP turbine blade tip clearance measurement and also allows X-rays to be taken during engine running. Engine accessories can be changed easily.

4.3 Core Engine Tests in the Stuttgart ATF

The objective of the project was to transfer core engine testing to the *Institut für Luftfahrtantriebe* (ILA) of the University of Stuttgart, first of all to support the tests being promoted by the German Aerospace Technology Programme. This involved the procurement and provision of all necessary systems, modification of the test facility, and commissioning of all control and measurement systems and the modified facility to demonstrate the following capabilities:

- The ILA altitude test facility supports the simulation of altitude flight conditions for a civil core engine, like the BR700, over a wide flight operating envelope. Inlet pressures from 5 to 240 kPa, temperatures from 210 to 430 K and inlet mass flows up to 140 kg/s can be provided by the facility.
- Fast transient manoeuvres with the core engine require that the test facility delivers repeatable pressure ramps of +/- 20 kPa/s, even at low flows. After appropriate modification including an automatic control of the valves, which control the air flow to the core engine, the required pressure ramps can be adjusted infinitely variable.
- The concept employed here for core operation and control of the test facility provides the necessary flexibility to suit the requirements for testing new technologies.
- The high availability and reliability of the plant combined with new control and sub-systems for oil and fuel supply etc. reduce the duration and cost of testing.

5.0 Concept and Test Configuration

5.1 Overview

A Control and Measurement System (CMS) based on a VXI bus system and three HP workstations takes over the control of the entire test data acquisition and conditioning process as well as the control and monitoring of all test activities. Special software implemented in a shell called CENTAURE is used for this purpose. The CMS communicates with the core engine controller (EEC) via the ARINC data bus and with the facility controller (FC) via analogue I/O cards. By means of position commands from a virtual thrust lever, the software controls the rotor speed, N2, via the EEC while also protecting the engine and the test facility from mal-functions and operating faults by appropriate logs.

5.2 Core Engine Demonstrator

The hardware of the core engine consists of the turbomachinery components, the annular combustion chamber and the secondary air system. They are mostly the BR700 engine standard parts, Figure 4. The combustion air is fed from the plenum chamber to the engine via a newly-installed intake section incorporating a venturi nozzle, Figures 5 and 6. A diffuser leads the air into a special intermediate casing

(swan necked duct), which is derived from the standard engine and serves as the core intake.

The intermediate casing also provides the suspension for the core engine and is the point where the thrust forces are introduced into the thrust frame. The latter also accommodates the fuel system. A water-cooled exhaust unit, with a nozzle area that can be adjusted in several stages, replaces the low pressure turbine. The accessories and the control system components such as the fuel system, the compressor variable stator vane mechanism, the sensors, the ignition system and the handling bleed valves are also standard engine components.

5.3 Control and Measurement System

The hardware consists of modular design and essentially comprises a VXI bus system with two chassis and a total of 25 plug-in modules. Three of these 25 cards are CPU's (HP 743i, 100 MHz). Two CPU's execute the test data acquisition. The third CPU runs the software for overall control and is hence called the Master Controller (MC). In addition, there are five A/I, four A/O, one D/O, two D/I cards and one timer card installed. One MXI card per chassis is available for inter-chassis communication. One ARINC card handles the communication between the CMS and the EEC.

The measurement system supports more than 500 thermocouples of various types, 1000 pressure signals provided by ILA's Scanivalve System, and 500 A/I's, 48 A/O's, 128 D/O's and 64 D/I channels. All measurement channels except the rotating Scanivalve System can also be used as input parameters for control purposes.

A software package provides open-loop and closed-loop control for all test activities. It is a real-time programme and has been designed for both manual and automatic operation of the integrated control system. In the automatic operation or closed-loop control mode it is possible to employ four different operation modes: Windmilling, Starting, Slow Transient and Fast Transient.

Special modes in the CMS provide the requested inlet conditions for the core engine dependent on the requirements of the test. The core engine inlet and outlet conditions can be commanded directly, e.g. as schedules versus the N2 speed or exclusively through altitude flight conditions. This allows to simulate the performance characteristics of the low-pressure compressor correctly.

The aerothermal and mechanical constraints on the operating range of the core engine by the low pressure system, are not present. Certain limiters on the principal process parameters are implemented in the MC software in addition to several EEC parameters. They provide protection for the whole system against excessive operating conditions.

5.4 Core Engine Controller

A FADEC similar to that used on the BR700-710 development engines for the Gulfstream V, was chosen as core engine controller and appropriately modified. The EEC as the main component of the FADEC is an electronic control system with two independent lanes. Each one has its own CPU and power supply. Using commands and information supplied by the ARINC 429 Digital Data Bus and from various sensors as input signals, the EEC regulates the engine thrust through a closed-loop control by varying the position of the fuel metering valve in the FMU.

In the primary mode the EEC uses EPR control and in the 'reversionary mode' it uses N1 control. The core engine provides no speed signal from a low-pressure shaft (N1). Therefore the control laws were altered in order to implement N2 as the controlled variable. The N1 control loop is modified to a continuously active N2 control loop. The EPR control loop is completely deactivated. The input signal for the thrust lever position command is modified to a N2 command that is no longer transmitted as an analogue signal, but now for the first time in engine testing via the ARINC data bus as digital signal.

The EEC software was adapted to implement the new control laws. They contain a primary mode that provides closed loop control of the mechanical shaft speed over the whole flight operating envelope of the engine.

5.5 Test Facility and Facility Controller

The facility operation diagram shows the most important part of the altitude test facility for running the core demonstrator tests, Figure 7. The inlet air of the core engine is supplied by compressor V0 and compressed to meet the engine intake pressure requirements. During altitude testing with sufficient low engine inlet pressures, the air can also be taken directly from the facility environment by using a suction compressor on the engine's exhaust side. The adjustment of the core engine inlet parameters is carried out by the valves L42 and L57 in the two parallel ducts.

The bypass valve L60 in parallel with the core engine diverts air round the core engine during rapid decelerations or under part-load conditions, thereby reducing the dead time for passing through the inlet section.

During fast transients, where rapid changes in pressure and temperature at the inlet of the core engine are required, the volume between the valves L42 and L57 and the core engine is critical for the transient behaviour of the facility. For a slam acceleration and a resulting rise in the inlet pressure P25, this volume has to be filled with air. A mass flow of air several times greater than the maximum engine flow capacity has to be supplied via the valves L42 and L57. When adjusting the inlet temperature T25 the air takes time to flow through that volume and hence produces a dead time. The heat exchange with the structural parts

causes a change in temperature and has to be considered.

To meet these requirements the FC performs a closed-loop control of the valves L42, L57 and L60. The MC provides the FC with the command values P25_C and T25_C, with the core engine flow demand W25_C and the rate of change of pressure $dP25/dt_C$. The temperature T25 is open-loop controlled by varying the mixing temperature according to the command value T25_C issued by the MC. In addition the heat exchange with the structure is taken into account by an appropriate model. The closed-loop pressure control used for correcting the open-loop control of P25 acts by means of a proportional element and an integral element by varying the command value of $dP25/dt_C$. For temperature control, the desired value of the mixing temperature is varied by an integral element.

A 166 MHz PC was used as FC for processing the measured values and the data supplied by the MC, calculating the open-loop and closed-loop control operations, and providing the valve control signals.

5.6 Sub-Systems

Unlike the entire whole engine, the BR700 core engine does not have a bevel gear drive from the high pressure shaft that powers the flight engine gearbox, hence it is necessary to incorporate a number of sub-systems.

- A self-contained N2-controlled lubricating oil system carries out the oil supply, vent and scavenge functions for the two bearing chambers of the core engine. The system supports - by means of a precise measurement of the bearing oil and air pressures and temperatures - the investigation of oil balance or new sealing technologies.

- The fuel system uses the BR710 standard fuel pump, fuel metering unit (FMU) and fuel-cooled oil cooler. An electric motor with variable speed control provides the power to the high pressure fuel pump.

- A closed loop cooling water system provides continuous circulation of pressurised water to the exhaust unit. Various cooling air systems provide for example cooling of the high-pressure turbine casing to maintain a defined value for blade tip clearances.

- To simulate the aircraft cabin air and anti-icing system, bleed air is taken off the core engine through butterfly valves which are driven by a self-contained hydraulic unit and controlled by the MC.

6.0 Commissioning and Validation

6.1 Interaction of the Systems

The interaction between various components of the system is illustrated in Figure 8. Before the test starts, the control operator of each of the control systems needs to provide the inputs for his system which is required for co-ordinated operation. All sub-systems are configured prior to test.

During testing, the operator feeds the demand values for speed N2 and the required flight conditions into the

MC. The MC generates the corresponding N2 command values in order to arrive at the target value of N2 in incremental stages. The command values are passed on both to the sub-systems and to the synthesis tables. The synthesis tables produce the command values for the core engine inlet and outlet conditions and a synthesised EPR command to feed the EEC functions dependent on EPR. The N2 and the EPR command values are sent to the EEC. Control is exercised by the closed-loop N2 control circuit of the EEC.

The command values for the core engine inlet conditions (P25_C, T25_C, W25_C, dP25/dt_C) are sent to the FC. The FC provides open-loop and closed-loop control of the core engine inlet pressure as well as adjusting the inlet temperature to the set value in a closed control loop.

The whole system can be operated under automatic control over a wide operating range, and very fast rates of change of N2, P25 and T25 can be achieved.

6.2 Integrating the Systems

A series of tests was performed on a Hardware/Software Integration Rig in order to integrate the EEC and the MC. The testing verified the communication between the systems, the stability and various emergency functions over a defined range of the engine flight operating envelope.

The ATF and the FC were used to carry out special preliminary tests with a throttling valve in place of the core engine for simulation purpose. This was to demonstrate how good the required inlet conditions for the planned transient core engine tests on the ATF can be achieved by the computer controlled facility.

The installation of the systems on the test facility in Stuttgart was finalised by an acceptance test procedure concentrating on the communication first. Then, the operating range of the engine was expanded from idle speed to maximum power and the functions of the control systems were verified successfully. Slow transient testing continued with the inlet pressure and temperature increasing with the speed. The behaviour of the pressure to follow the command, in particular, proved to be excellent. Finally the acceleration and deceleration times were subsequently reduced further to slam manoeuvres.

Accelerations from high idle speed to maximum power were achieved in approximately 4 seconds at sea level static conditions and approximately 10 seconds at 40,000 ft altitude, Figure 9. Since the dead time in the temperature control could only partly be compensated by the compression or expansion effect, notable divergences occur in the actual temperature settings. In future, however, it is possible to compensate for most of the slight lag of the temperature during the rapid acceleration by installing an extra dead time element to allow the temperature signal to be issued with a lead time.

6.3 Core Engine Tests

During and after commissioning a series of experiments to support the BR715 Engine Development Programme and the German Aerospace Research Programme were carried out with BR710 and BR715 standard core engine components.

6.3.1 Emission Gas Measurement. An emission gas analysis test was carried out to provide the datum emission levels of the core engine with a standard combustor. This was necessary for comparison with future emission test results gained from a core with a staged combustor.

Compared to combustor rigs, the emission gas analysis on a core engine allows to verify the emission levels of a full annular combustor in an engine environment with representative pressure and temperature levels. Due to the gas sampling directly in the core gas path, the measurement in a core engine provides higher quality results.

Additionally the core engine and facility will be matched aerothermally to simulate various sea level and altitude flight conditions for the whole range of derivatives of the BR700 engine family. This is possible by adjusting the aerothermal combustor inlet conditions at a constant fuel-air-ratio, Figure 10.

A mobile emission gas analysis system controls the whole measurement process of calibration, data recording and analysis. According to ICAO standard the system uses the following methods for gas analysis:

- SAE smoke meter (filter technique) for smoke detection.
- Non-dispersive infra-red analyser (NDIR) for CO and CO2 detection.
- Flame ionisation detector (FID) for UHC detection.
- Chemi-luminescent detector (CLD method) for NOX detection.

Additionally, to determine the combustion efficiency, the concentration of Oxygen and Nitrogen is being measured as well as the air humidity which influences the measuring method based on infra-red analyser.

The tests confirmed the excellent emission standard of the BR700 combustor. The measured value of the BR710 NOX emission level provides a margin of 45 % to the current ICAO limit. Compared to other engine types the BR710 with the standard combustor is already one of the leading low emission engines.

6.3.2 Thermal Paint Test. A thermal paint test with BR715 standard combustor and high pressure turbine was carried out on the core engine to support the BR715 development programme. This test was used to investigate and evaluate the surface temperature distribution of the hot end components. The components of high interest were the stage one and two turbine blades and the combustor can as well as heat shields and burners. Furthermore the temperature distribution of the HP turbine discs and the combustor and turbine casings were assessed. By means of using various types of turbine blades with six different thermal paint types and also different blade cooling

design standards (with different cooling hole configurations), it was possible to assess the efficiency of the turbine blade cooling system, Figure 11. Although this test was a very short one, it is also one of the most difficult tests as it allows for only one attempt once the core is lit. The core engine and the inlet conditions had to be matched aerothermally to achieve the required target conditions (HPC exit and HPT entry temperatures). This is very important for accurate results. The stabilisation time of about 5 minutes on condition with maximum stator outlet temperature ensured that the thermal paint reached a stabilised temperature with minimum thermal paint loss due to erosion effects. An overshoot of the inlet conditions would have changed the thermal paint colours to a less accurate temperature, with no opportunity for corrective actions, causing this part test to have failed. The accurate core engine control guaranteed the right inlet conditions and the test objective was achieved. Based on the validated test data, a redesign of the turbine blade cooling system was incorporated during a relatively early design stage. The thermal behaviour of fuel injectors and combustion heat shields with blocked cooling holes was also assessed. Furthermore the validation of the aerothermal models was possible by comparison of the acquired test data against the calculated values.

6.3.3 Vibration Survey Test. Vibration surveys of the modified HPC blading and of the new HPT blading were carried out to support the BR715 development and certification. Especially the HPT certification test covered the whole operating range of the engine incl. an overspeed margin of 5 %. The target is to prove that the Eigenfrequencies and stresses of the blades are not critical to the integrity of the turbine.

During the slow accel to a maximum mechanical rotor speed which is 5 % above the value the BR715 engine will ever see in service and during the following decel the stress signals were measured by the strain gauges on the blades and transmitted via a slip ring unit to the mobile integrated dynamic data analysis system. To keep the turbine temperatures low, the test was carried out with an increased final nozzle area and more closed variable guide vanes of the HPC. As during this test very high levels of HPC exit and HPT entry temperatures are achieved, it is very important, that the facility delivers a steady core inlet temperature to avoid turbine overtemperature. Vibration surveys of the turbine have to be successful from the beginning, as the life time of the strain gauges on the hot blades is very limited.

Especially a core engine test supports the combination of a vibration survey and thermal paint test during one test campaign.

7.0 Prospects for Future Testing

7.1 Staged Combustor Core Demonstrator

The next test campaign concentrates on the validation of a core demonstrator equipped with a fuel staged, low-emission dual annular combustion chamber. There will be several technical challenges employed by the new technology.

The fuel staged combustor consists of a pilot fuel injector stage for low power and an additional main fuel injector stage for high power running, Figure 12. The increased complexity of the systems will cause an additional challenge. A staging valve control unit has been developed to execute specified control algorithms and to provide closed-loop control of the fuel staging valve position. All additional functions will be integrated in the existing hardware and software of the systems. The special challenge of this system will be to exactly control the split of the fuel between the two injector stages, especially during transients. This will guarantee high efficiency, high safety against flame out, low emission and fast response during engine transients. The main targets will be to demonstrate a reduction in NOX emission to a level of 35 % of the current ICAO limit and to compare the handling characteristics of the engine with a conventional combustor engine, Figure 13. Testing will cover the whole flight operation envelope and will include relight testing and critical handling cases.

A second test campaign will be used to additionally validate advanced technology which is currently in its development phase:

- The staged combustor will undergo a second test to validate an improved standard of the can and the fuel and control system.
- Blisk technology in the HP Compressor and a composite hybrid variable stator vane mechanism will help to reduce engine weight.
- An innovative heat management system and seal design for the HP turbine will improve the specific fuel consumption by decreasing the amount of cooling air for the HPT, it will increase the life of the turbine discs and will reduce weight.

The testing again will concentrate on the demonstration of the reduced level of emission and will be used to optimise the engine's handling capabilities over the whole flight operation envelope. Surge tests and water ingestion tests will become necessary to evaluate the response of the new combustor and control system at unforeseen events and inclement weather conditions during operation.

7.2 Strategy for Future Core Engine Technology

Due to the increasing air traffic the main technical targets for future engine concepts are to decrease fuel consumption, emission and noise. The commercial challenges will be to reduce development, production and maintenance cost and to increase the reliability of the engine. To fulfil these requirements and to remain competitive, new technology has to be acquired.

Within the initiative of the German Aerospace Research Programme Part "Engine 3E" (Efficiency, Economy, Environment), which is being promoted by the Federal Ministry of Education, Science, Research and Technology, a technological base for future competitive engine development skills will be established.

The following targets for an engine concept with a bypass ratio beyond 12 and an overall pressure ratio of 50 will be aimed at Figure 14:

The German Aerospace Research Programme is going to enter the second concept phase. It will comprise the development of an advanced technology core demonstrator with new compressor, combustor and turbine components and will undergo validation testing in about 3 years time. This demonstrator will be characterised by a high pressure ratio HPC (> 22) with increased exit temperature and 3D-Wide-Chord-Blading, an extremely low-emission, dual annular combustor with a staged fuel system, a 2-stage high temperature HPT with an optimised cooling concept and a HPT Stator Outlet Temperature beyond 1800 K and an advanced control system.

A wide range of tests supporting a future certification programme will be planned and used to validate the new technologies.

- Vibration surveys for the investigation of the blade dynamics using telemetry to transmit the strain gauge signals.
- Performance investigations over the whole flight operation envelope to verify the benefit in fuel consumption.
- Component performance investigation will comprise tests to map the compressor and turbine characteristics and to verify Reynolds No. effects.
- Emission gas measurement and analysis to demonstrate the reduction in NOX of the new combustor standard.
- Handling tests will be used to optimise the response of the staging valve control logic.
- Simulated inclement weather condition testing will verify the combustor's robustness against flame out and provide data to set up a control logic for inclement weather condition.
- Thermal survey testing to validate the thermal model by the use of rotating temperature measurements and by running square cycles.
- Blade tip clearance measurements will be used to validate the running clearances of the turbomachinery components.
- Thermal paint testing to verify the surface temperatures of the new blading and other components.
- Endurance testing for cyclic evaluation of the hot end components will require fast transients with a schedule of inlet pressure versus rotor speed and a constant inlet temperature.

With the advanced core concept the BR700 engine has the potential for 35000 lbs thrust. A possible time scale for development and certification is shown in Figure 15.

8.0 Conclusions

The reduction in development time for civil engines, combined with the need to introduce advanced

technology in each new product, adds more and more risk to the product realisation phase. A strategy has been described how to introduce new technology in the product development phase with an acceptable level of risk. As a consequence, BMW Rolls-Royce has selected the BR700 core engine as platform for technology validation using the Stuttgart ATF.

A series of testing has demonstrated, that core testing has been successfully used to support the BR710 and BR715 certification programme. Therefore, our ability to run core engines on the ATF in Stuttgart has established a solid base on which future technological projects can be developed. More testing are planned for 1998/99 and, in addition to the validation of the staged combustor, tests are planned for the validation of a BLISK HP compressor with composite hybrid variable stator vanes and an innovative heat management system and seal design for the HP turbine.

Our mid/long term plans for the second phase of the German Aerospace Research Programme demonstrates, that core engine testing is an integral part of our strategy for the 21st century.

9.0 References

- Ref. 1:** G. Kappler, R.J. Moore, J. Hourmouziadis: Hochleistungs-Turbo-Fan-Triebwerke, Ein Familienkonzept, Annual Proceeding DGLR, 1992, Bremen, Germany
- Ref. 2:** R. Hönig, S. Chivers, G. Kappler: BR710 Powerplant Development, 44th Annual Conference, Canadian Aeronautics and Space Institute, April 1997, Toronto, Ontario, Canada.
- Ref. 3:** U. Heßler, H. Richter: Der Aufbau technologischer Fähigkeiten bei der BMW Rolls-Royce GmbH und deren Umsetzung in neue Triebwerksprojekte: Der Stellenwert der nationalen und europäischen Förderprogramme für ein europäisches „Joint Venture“ Unternehmen, Annual Proceeding DGLR, 1997, München, Germany
- Ref. 4:** K.-J. Schmidt, R. Merten, M. Menrath, W. Braig: Adaptation of the Stuttgart University Altitude Test Facility for BR700 Core Demonstrator Engine Tests, ASME Turbo Expo '98, 2. - 5.6.1998, Stockholm, Sweden

10.0 Figures

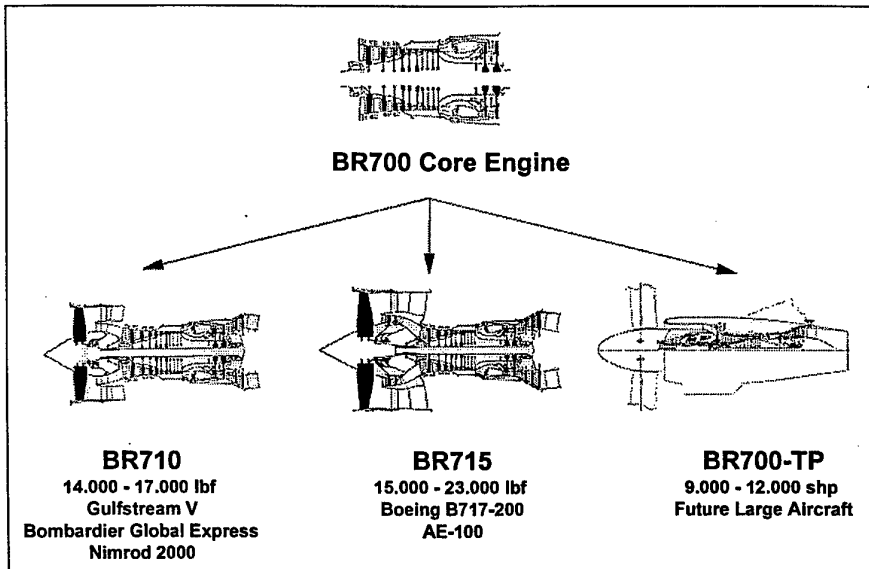

Figure 1:
BR700 Engine Family Concept

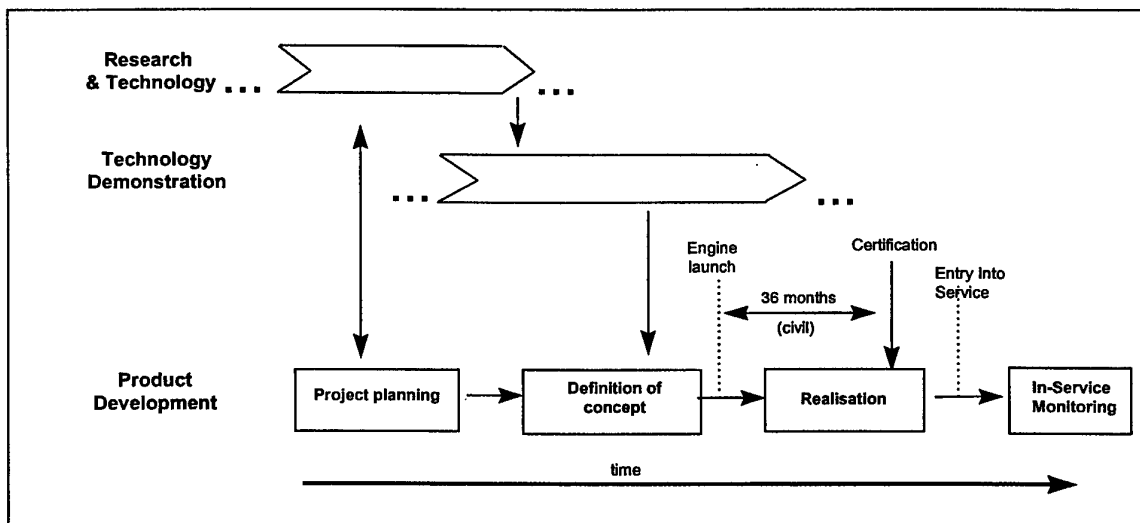

Figure 2:
Strategy how to introduce advanced technologies into future products

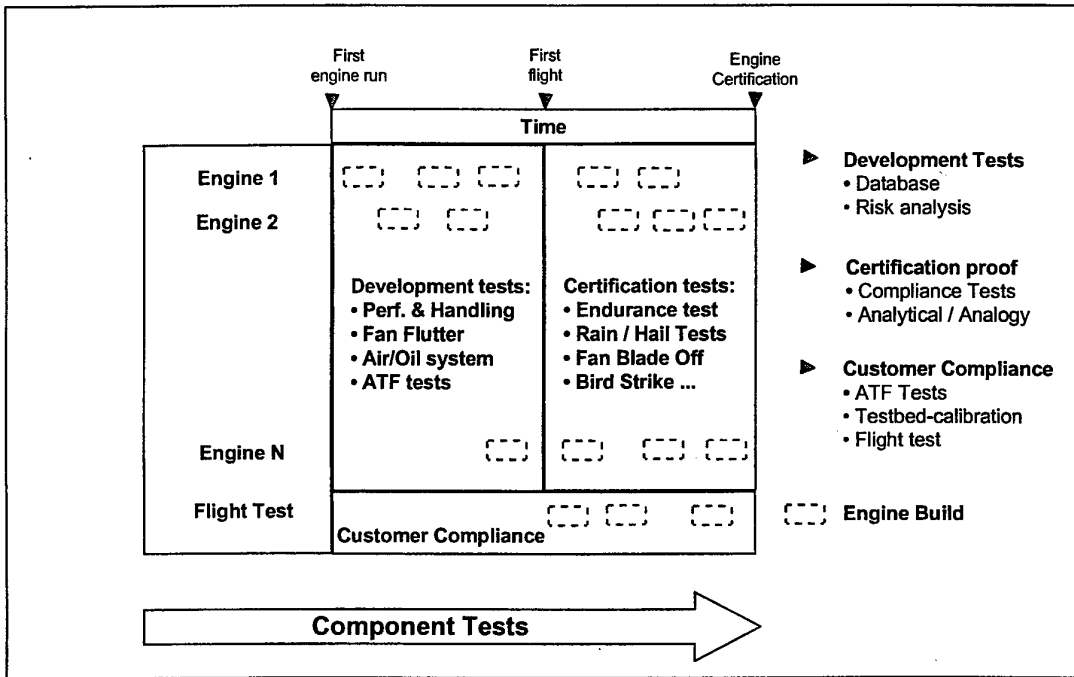

Figure 3:
Schematic of a typical Engine Development Programme

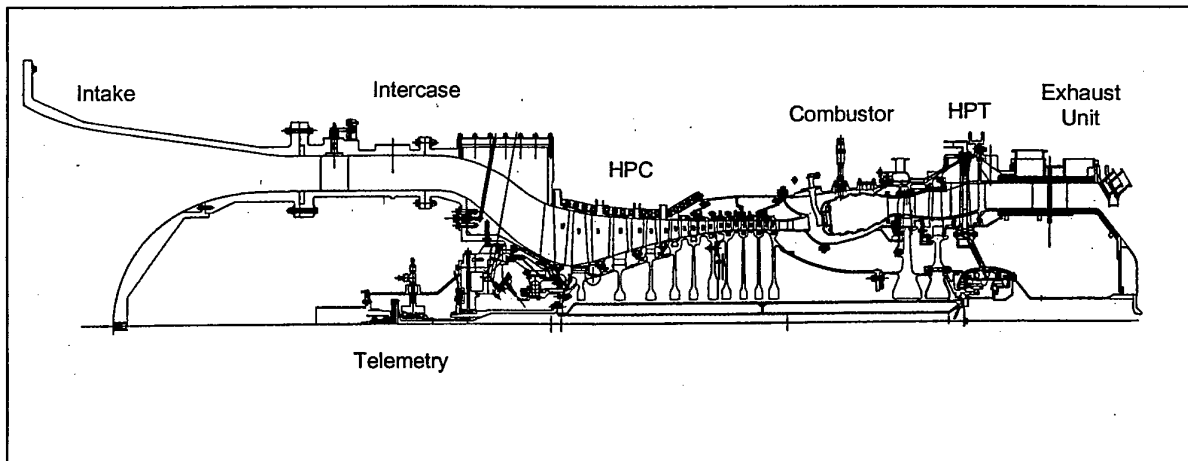

Figure 4:
Cross-section of BR700 Core Engine Demonstrator

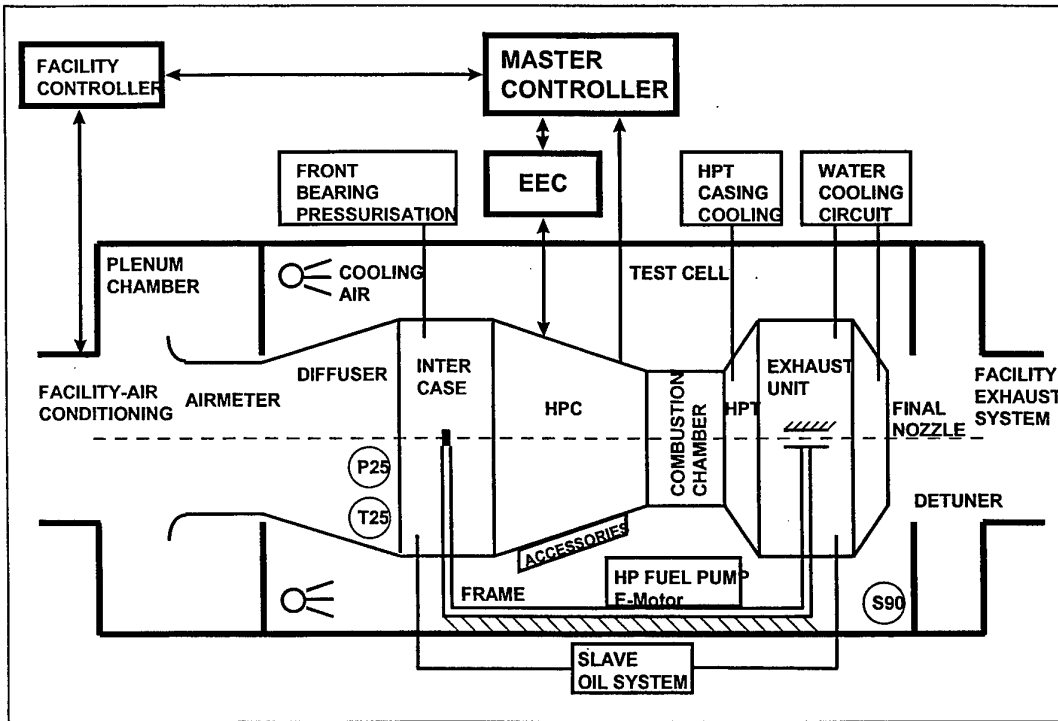

Figure 5:
General Arrangement of the Test Bed

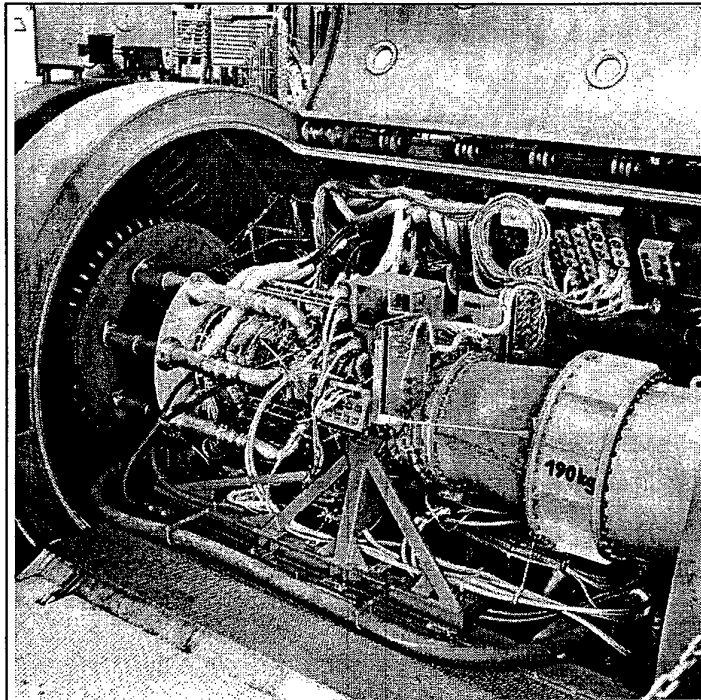

Figure 6:
Test Cell with Core Demonstrator

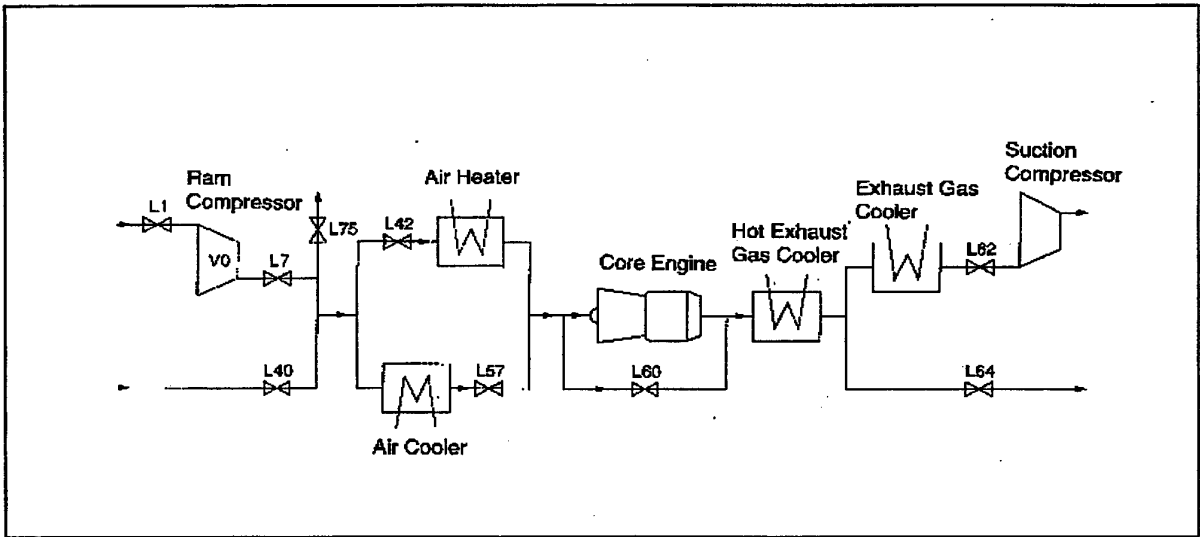

Figure 7:
Facility Operation Diagram for Core Demonstrator Test

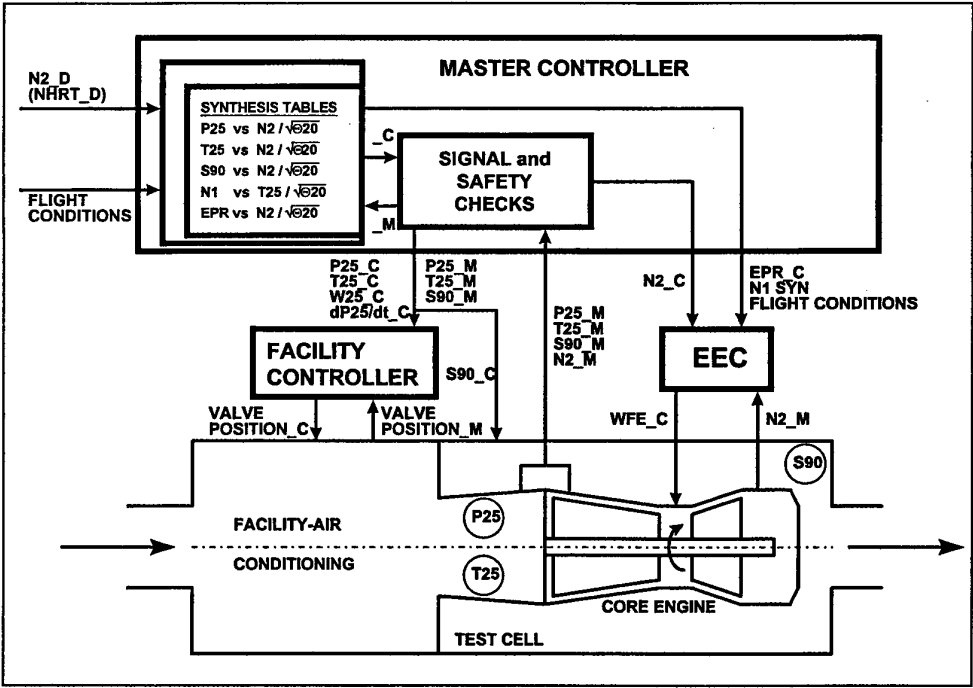

Figure 8:
Control Systems Integration

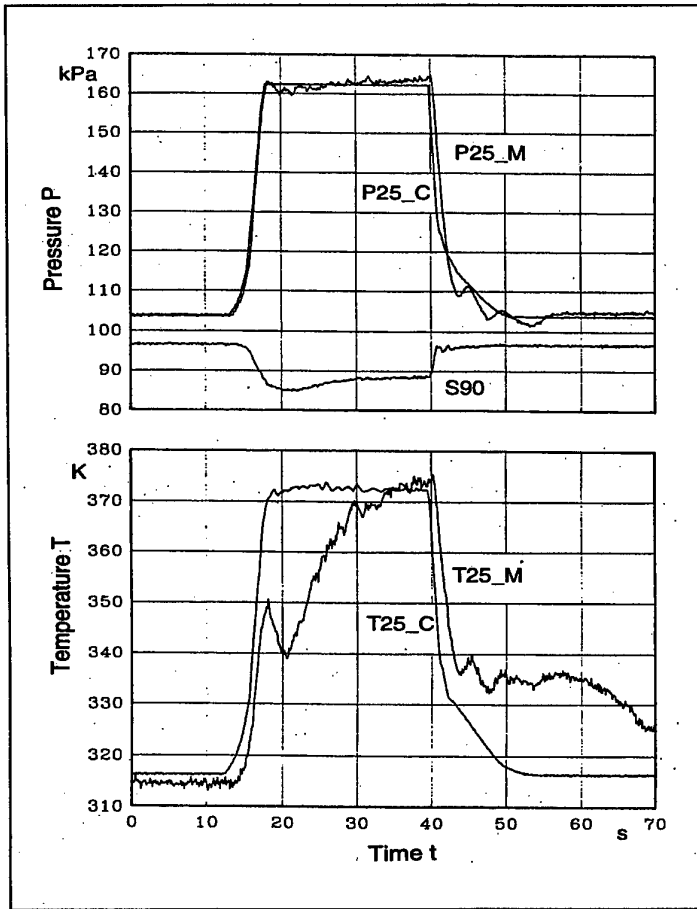

Figure 9:
**Commanded and Measured Values of the Core Engine
 Inlet Parameters at Sea-Level Static Conditions**

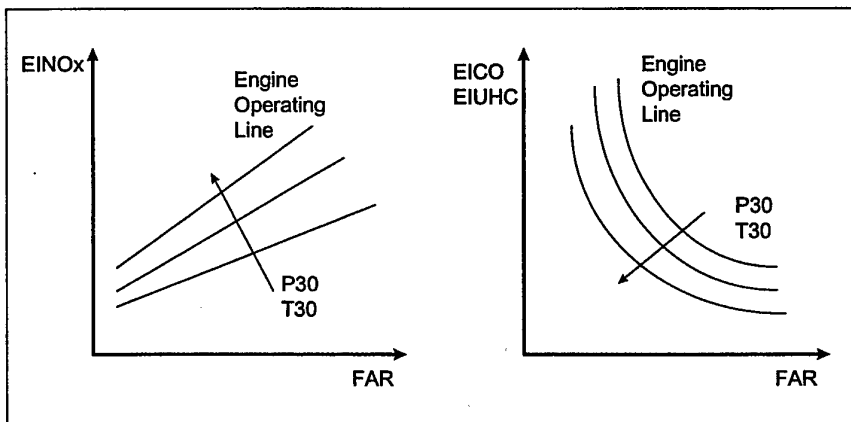

Figure 10:
Simulation of various BR700 Engine Types for Emission Gas Analysis Testing

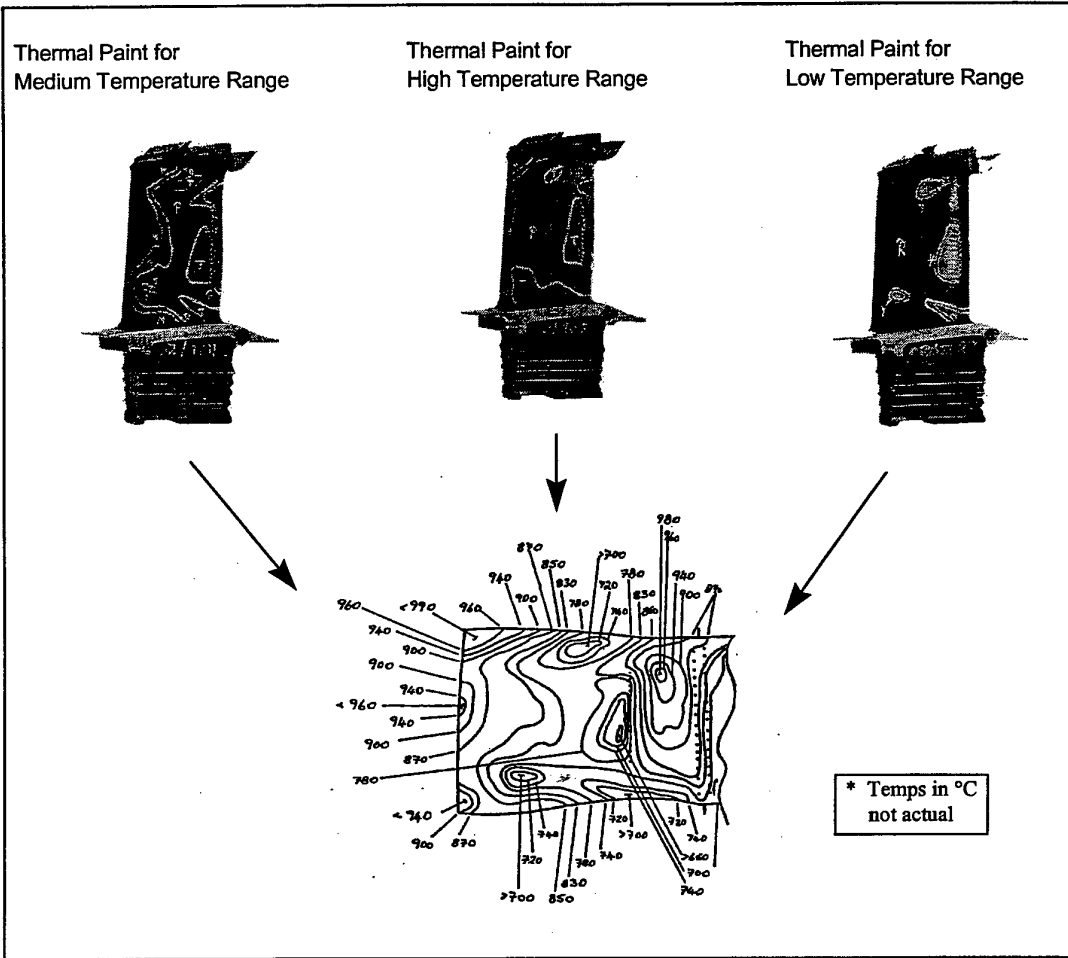

Figure 11:
Surface Temperature Measurement of Turbine Blades using Thermal Paint

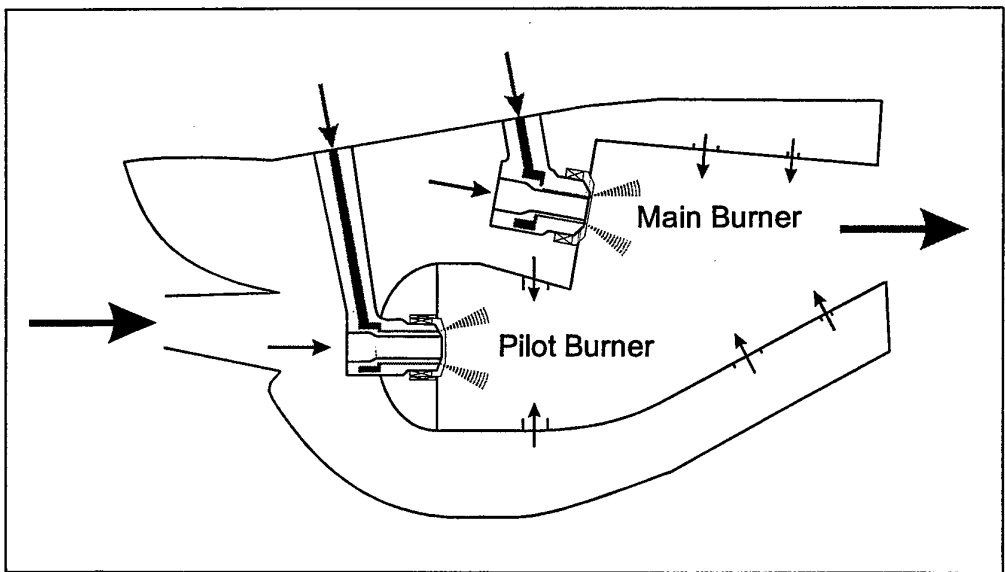

Figure 12:
Fuel Staged Dual Annular Combustor

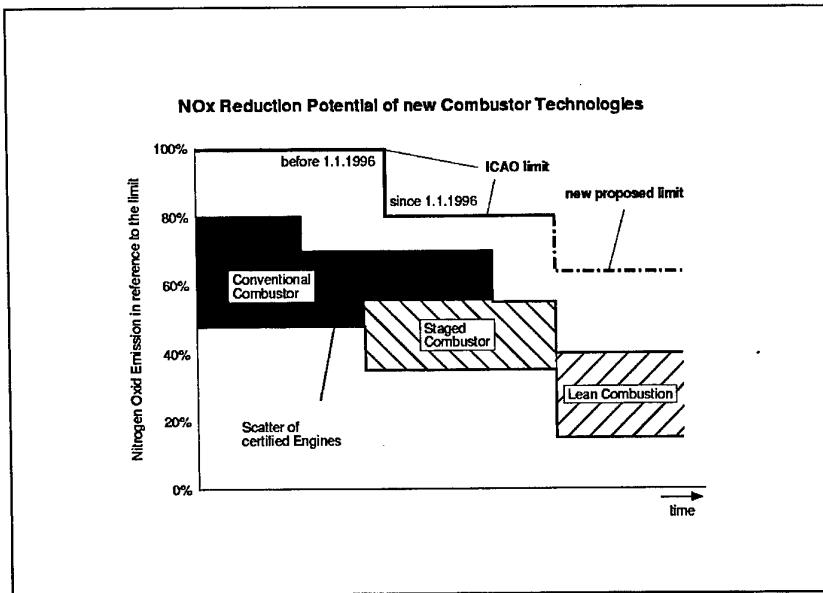

Figure 13:
Potential for NOX Production of New Combustor Technology

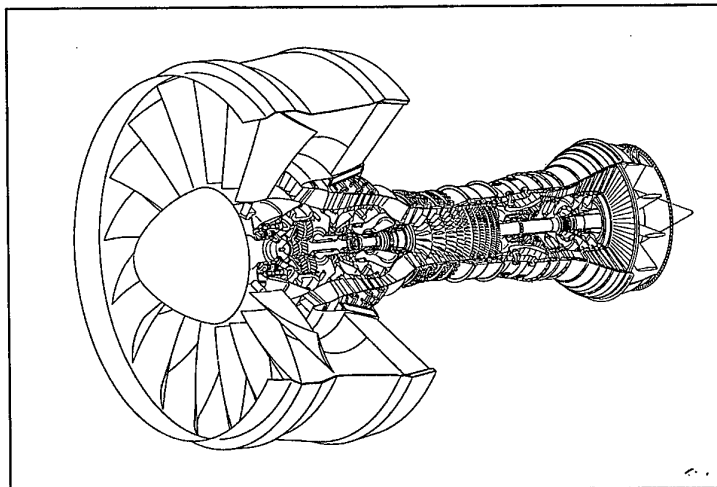

Figure 14:
Example of an Engine Concept within the German Aerospace Research Programme

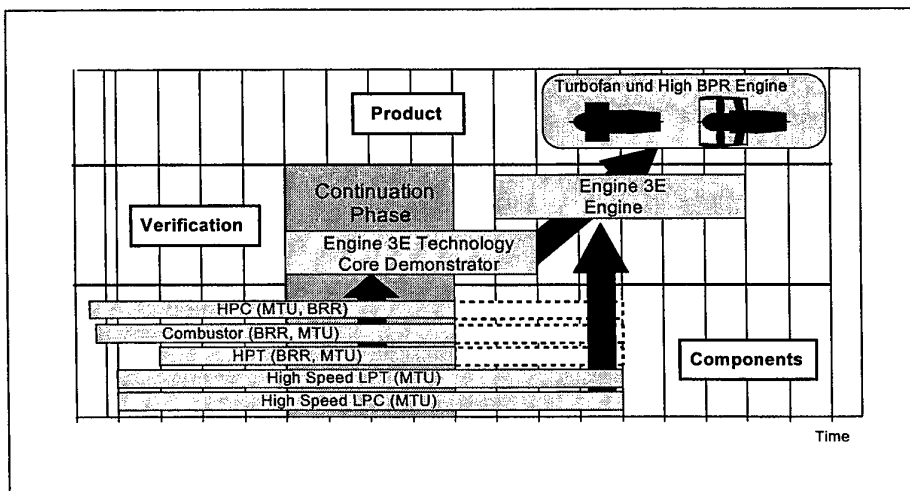

Figure 15:
Concept of the planned second phase of the German E3E Technology Programme

**Test Technology Needs Identification for the 21st
Century United States Air Force**

Mr C D Tompkins, Air Force Flight Test Center, Mr D Hite,
Space and Missile Systems Center, Mr T Best, Arnold
Engineering Development Center and Ms C Schurr,
Air Force Development Test Center, USA

TEST TECHNOLOGY NEEDS IDENTIFICATION FOR THE 21ST CENTURY UNITED STATES AIR FORCE

Clifford Tompkins

Air Force Flight Test Center, Edwards Air Force Base, California

Dale Hite

Space and Missile Systems Center, Kirtland Air Force Base, New Mexico

Tom Best

Arnold Engineering Development Center, Arnold Air Force Base, Tennessee

Cynthia Schurr

Air Force Development Test Center, Eglin Air Force Base, Florida

Abstract

The United States Air Force (USAF) developed a new vision (*Global Engagement: A Vision for the 21st Century Air Force* [USAF 1997]) to exploit the strengths of modern air and space power through a set of core competencies, guide the evolution of the USAF from an "Air and Space Force" to a "Space and Air Force," and provide a focus for 21st century USAF Test and Evaluation (T&E). Future implementation of this vision depends on the pursuit of a number of technologies – efforts that will have an impact on both required T&E capabilities and T&E technology needs.

This paper addresses ongoing efforts to meet these goals by discussing the test technology needs identification process trail from visionary-type documents such as *Joint Vision 2010, America's Military: Preparing for Tomorrow* (J. Shalikashvili 1995) and *Global Engagement: A Vision for the 21st Century Air Force* (USAF 1997), to T&E capability requirements definition, and to the identification of future test technology needs. This paper specifically addresses the efforts of the USAF T&E communities' development of: (1) a USAF T&E Mission Support Plan (MSP), (2) a Tri-Service Required T&E Capabilities Analysis (RTECA), (3) USAF Annual Planning and Programming Guidance (APPG), and (4) a USAF T&E Requirements Assessment Team (TERAT) database. A new notional, formalized process for test technology needs identification using these studies and plans as a basis will be presented. This new process provides for integrating existing and future warfighter requirements and strategic guidance into identifiable T&E capability requirements, which in turn, allows for identification and discussion of new test technology needs for 21st century USAF T&E.

Introduction

United States Air Force T&E is an outgrowth of a rich weapons systems research, development, and acquisition heritage. Test and evaluation evolved to support the development of weapons systems necessary to protect our national interests. Preparing for the future of T&E, especially in today's uncertain post-Cold War environment, presents a multitude of new and difficult

challenges. What we will have to test and how we will test are changing. Other factors such as consolidation, environmental issues, acquisition reform, and budget reductions will require changes in our organizations, processes, and infrastructure. Our focus must be clear and our game plan coordinated; we must improve efficiency and reduce overhead while preparing the people and infrastructure to meet the T&E demands of future weapon systems. One of the ways to do this is to improve the technology of our T&E systems.

However, numerous questions exist regarding the future of USAF T&E. What essential capabilities must be present in the T&E infrastructure between now and the year 2010? What capabilities are required beyond 2010? What improvements are required? Where do we start the process of test technology needs identification for the USAF community? What provides the guidance for directing us into the 21st century?

The USAF has been working diligently for the past several years to answer these questions and to prepare for the 21st century. A view of the test technology needs identification trail from top-level vision to needs identification will be presented.¹ We will only touch briefly on the vision and guidance, and concentrate on four studies that the USAF has either chartered or participated in. We will outline the objective, scope of the effort, process used, limitations, and present a summary of each of the studies. The intention is to show there currently is no single process for test technology needs identification in the USAF. We will illuminate the positive aspects and discuss the limitations of each of the studies, and attempt to provide a new notional, singular process for identification of test technology needs for the 21st century USAF.

Visions

We must start at the top in the test technology needs identification process. Many of the visionary type documents are very abstract, and thus necessarily macro in nature and contain very few references to specific

¹One area that requires clarification to avoid confusion is the use of the terms "T&E Requirement" versus "T&E Need." A "T&E Requirement" is best described as "what T&E tasks we need to accomplish." A "T&E Need" is described as "what assets we need to conduct a particular type of test."

weapon systems, which makes it difficult to link to T&E. However, these documents constitute the starting point for our modernization planning process. The USAF T&E community looked to the Joint Chiefs of Staff for this start. General John M. Shalikashvili, then Chairman of the Joint Chiefs of Staff provided the conceptual template for how America's Armed Forces will fight in the early 21st century. This template is *Joint Vision 2010, America's Military: Preparing for Tomorrow* (Reference 1). *JV2010*, as it is called, provides guidance on how we will leverage technological opportunities to achieve new levels of effectiveness in joint warfighting.

Joint Vision 2010

The Chairman of the Joint Chiefs of Staff *Joint Vision 2010 (JV2010)* gives us some indication of how the United States (U.S.) expects warfighting to be conducted in the future, and thus what general types of technology the USAF T&E community must be prepared to evaluate. This vision of future warfighting, assuming improved intelligence and command and control to be available in the "information age," goes on to develop four operational concepts: dominant maneuver, precision engagement, full dimensional protection, and focused logistics. *JV2010* proclaims that "full spectrum dominance will be the key characteristic we seek for our Armed Forces in the 21st century." These four concepts help to achieve that dominance. *JV2010* further proclaims "Imperative of jointness, we must find the most effective methods for integrating and improving interoperability; we must be fully joint; institutionally, organizationally, intellectually, and technically." We must attempt to incorporate jointness into each of the four operational concepts.

JV2010 states "Major improvements in U.S. military capabilities should arise from simultaneous developments in battlespace awareness; advanced command, control, communications, computing, and intelligence (C4I); and precision force. Individually, these new systems portend sharply increased effectiveness. Collectively, they promise to widen the lead of the U.S. military over its competitors, even in the face of declining defense budgets." Called the "system of systems" military instrument by then Vice Chairman of the Joint Chiefs of Staff Admiral Owens, the T&E community can expect to be asked to evaluate multi-platform weapon systems or systems of weapon systems in the future.

JV2010 identified several advancing technology trends. Long-range precision capability, combined with a wide range of delivery systems, is emerging as a key factor in future warfare. The ability to produce a broader range of potential weapons effects will enhance precision capability. Advances in low observable technologies

and the ability to mask friendly forces will continue. Improvements in information and systems integration technologies will significantly impact future military operations by providing decision makers with accurate information in a timely manner, gaining them dominant battlespace awareness for the U.S.

JV2010 concludes "The combination of these technology trends will provide an order of magnitude improvement in lethality." The "increasingly lethal battlespace will increase the importance of stealth, mobility, dispersion, and the ability to operate at a higher tempo." "Greater mobility and increased dispersion will, in turn, require additional communications and coordination capabilities since the synchronization of these dispersed elements will become even more important."

A key theme of *JV2010* is the emerging importance of "Information Superiority." The document declares that "we must have information superiority: the capability to collect, process, and disseminate an uninterrupted flow of information while exploiting or denying an adversary's ability to do the same."

Global Engagement

The next step in the test technology needs identification process was to look at USAF visions for the 21st century. The post-Cold War "Global Reach - Global Power" vision has guided the USAF for the past 6 years. Because of change and uncertainty, a new vision was required to carry us into the 21st century. Therefore, in response to the uncertainties of the post-Cold War era and consistent with the Chairman of the Joint Chiefs of Staff vision of "Full Spectrum Dominance," the USAF developed a new vision to guide it into the first quarter of the 21st century, *Global Engagement: A Vision for the 21st Century Air Force* (Reference 2). *Global Engagement* will exploit the strengths of modern air and space power, speed, global range, stealth, flexibility, precision, lethality, global/theater situation awareness, and strategic perspective through a set of core competencies: Air and Space Superiority, Global Attack, Rapid Global Mobility, Precision Engagement, Information Superiority, and Agile Combat Support. The emerging reality of the 21st century is that, largely through the strengths of Air Power, it will be possible to find, fix or track, target, and hit anything that moves on the surface of the earth.

Global Engagement addresses the entire USAF - people, capabilities, and infrastructure - and charts the course of the USAF into the 21st century. In this context, *Global Engagement* will guide the evolution of the USAF from an "Air and Space Force" to a "Space and Air Force" and provide a focus for the future of T&E. However, the vision is only the first step in the USAF's approach to

long range planning. This vision establishes overall direction, but the USAF needs to develop a long range plan to make this vision come true. This effort has begun, but has not been completed. Thus, any use of *Global Engagement* for help in test technology needs identification requires a liberal interpretation of what the future holds.

Futuristic Projections

A number of recently published futuristic studies and projections address the next 30 years. These include *Defense Science and Technology Strategy* (Reference 3), *New World Vistas: Air and Space Power for the 21st Century* (Reference 4), and *2025 Executive Summary* (Reference 5). These documents address futuristic projections for the USAF and the Office of the Secretary of Defense. The *Defense Science and Technology Strategy* (Reference 3) along with three support documents: the *Basic Research Plan* (Reference 6), *Joint Warfighting Science and Technology Plan* (Reference 7), and *Defense Technology Area Plan* (Reference 8) initiated a corporate science and technology planning process to more effectively link products of the Defense Science and Technology program with the needs of the warfighter. As such, it provides information on technologies the science and technology community is working on that tie directly to warfighter requirements.

New World Vistas was a Secretary of the Air Force and Air Force Chief of Staff directed study accomplished by the Air Force Scientific Advisory Board. They commissioned this study to identify those technologies that would guarantee air and space superiority of the U.S. in the 21st century. *New World Vistas* documents enabling technologies, capabilities, and future concepts and systems in over 2,000 pages in 15 volumes.

2025 Executive Summary was also an Air Force Chief of Staff directed study, but conducted by the Air Force Air University. His direction was to "generate ideas and concepts on the capabilities the U.S. will require to possess the dominant air and space force in the future." The study included use of a forecasting model that addressed key drivers to define a strategic planning space. This report consisted of 41 white papers on more than 3,300 pages.

These three studies provide a wealth of information of potential future systems that would require T&E. However, there has been no effort to formally and collectively review and document the potential impact to USAF T&E of the projections in these documents.

Recent Studies

The USAF, during the period 1995 through 1998, has participated in four major studies (USAF T&E Mission

Support Plan (MSP), Tri-Service Required T&E Capabilities Analysis (RTECA), USAF Annual Planning and Programming Guidance (APPG), and USAF T&E Requirements Assessment Team (TERAT)) that provide some insight into test technology needs for the 21st century. We will discuss these studies independently in terms of their objective, the scope of the effort, process used, limitations, and a brief summary. An attempt will then be made to take the common threads between the studies, and propose a new conceptual approach to identification of T&E capability requirements, and thus, test technology needs.

Mission Support Plan (MSP)

Introduction. The USAF vision drives the Air Force Modernization Planning Process. The Modernization Planning Process in turn, provides the corporate plan for leading the USAF into the 21st century. The Modernization Planning Process involves a strategy-to-task, task-to-need, and need-to-solution methodology. The T&E Mission Support Plan (MSP) was developed as a part of the Modernization Planning Process by a team of planners from the Single Face to Customer offices and headquarters personnel.

Objective. The T&E MSP documents how T&E organizations plan to meet the long range strategic plans and vision of the USAF. This plan differed from others in that it took a long-range view, up to 25 years, and linked strategies, tasks, needs and solutions together into a plan for the T&E community.

Scope. The MSP is the primary planning document capturing both developmental test and operational test requirements as well as the test investments needed to modernize the test infrastructure in order to provide cost effective and efficient support to current and future weapon system acquisitions. The T&E MSP was developed from an analysis of the operational command Mission Area Plans, the Science and Technology - Technology Area Plans, Air Force Operational Test and Evaluation Center's operational test requirements, test needs of on-going and planned weapon system acquisitions, and the strategic vision of the U.S. Department of Defense (DoD). Based on these documents, T&E developed a task area focus to provide a corporate view toward test requirements and infrastructure modernization planning. The T&E task areas were: Aircraft-Propulsion-Avionics, Armament-Munitions, C4I, Electronic Warfare, and Space.

Process. Modernization Planning is the process the USAF uses to define its future investment roadmap. Air Force Policy Directive 10-14, *Operational Requirements and Modernization Planning Process* (Reference 9) and Air Force Instruction 10-601, *Air Force Mission Needs and Operational Requirements* (Reference 10) describes this

process. Accordingly, the T&E MSP development team adhered to this USAF Modernization Planning Process.

Since Air Force Policy Directive 10-14 specifically addresses USAF mission areas (such as Theater Missile Defense, Counter Air, Airlift, etc.), mission support organizations (such as T&E) must adapt this framework for future planning. Thus, mission support modernization planners must take a broader perspective because their area of responsibility is to support all mission areas and operations. The approach involved an Environmental Assessment, Mission Support Assessment, Mission Support Needs Analysis, and finally development of a MSP.

The first step involved an evaluation of the environment in which the mission support area operates. This effort is often referred to as strategic planning and the resultant strategic assessment provides the backdrop to the MSP. For our effort the Environmental Assessment included reviews of the visions for the USAF such as *Joint Vision 2010* and *Global Engagement*. This assessment took into account items such as customer requirements, budgetary constraints/pressures, technology opportunities, and organizational structures. The next step in modernization planning involved the strategy-to-task process as its principle tool to identify the tasks required to accomplish the assigned function. This process began with a review of the following documents: *A National Security Strategy of Engagement and Enlargement* (Reference 11) and *National Military Strategy of the United States of America 1995* (Reference 12), which yielded operational command deficiencies, which in turn, provided key inputs into the identification of T&E support functions. This information, along with the science and technology community requirements from their Technology Area Plans, and the developmental and operational test requirements of planned and on-going weapon system programs formed the basis for the T&E Mission Support Assessment. After the Mission Support Assessment task identification, the team conducted a Mission Support Needs Analysis using the task-to-needs process. This process assessed whether current T&E capabilities could adequately satisfy the tasks as identified in the Mission Support Assessment. If not, the team documented the deficiencies.

The final element of modernization planning, the MSP, summarized and used the products of the Mission Support Assessment (tasks) and Mission Support Needs Analysis (deficiencies) to identify key technologies and resource modernization efforts required to correct identified deficiencies. The MSP product is a modernization roadmap. The T&E MSP serves as the primary planning document and provides the proper

focus for limited investment dollars. Leading up to this step, the T&E MSP team operated in a fiscally unconstrained environment. During this step, the team evaluated and prioritized the proposed investments and developed funding strategies. In the near-term planning horizon (2 to 6 years), the T&E MSP process resulted in a detailed investment project list for each task area with planned funding. In the mid-term planning horizon (7 to 16 years) the MSP process identifies key modernization areas the USAF T&E infrastructure must concentrate on to address the identified long-term deficiencies. In the far-term (out to 25 years), the T&E MSP provides the vision of the future. As such, the MSP linked the requirements identification process with the investment and budgeting process.

Limitations. A primary limitation of the T&E MSP came from the fact that the USAF vision was fiscally unconstrained. This meant that the tasks, needs and solutions defined in the T&E MSP were also unconstrained. Decisions on what solutions should and should not be funded, that support program plans identified in the out-years, were difficult because no one knows whether the program will be funded or not.

From a procedural perspective, additional limitations were numerous. This was the first MSP developed, as such; the process was not entirely efficient. The timeframe allotted to accomplish the task was short, and the manpower was limited. In addition, application of the modernization process as it relates to development of the MSP was a learning process. We understood the basic task, but had to determine what the input sources were, where to obtain the warfighter deficiencies, the military strategies, etc, and had very little direction from higher headquarters on what the MSP was to be. Therefore, the team had to develop the MSP from the ground up.

Summary. The first edition of the T&E MSP was a good attempt at converting strategies-to-task-to-need-to-solution. It would have been a better product if the reviews of the strategies had been an on-going process all year and not a quick look when the T&E MSP was being developed. However, it still provided excellent input into the Air Force Annual Planning and Programming Guidance. The MSP effort as a whole provided one of the best looks at T&E capability requirements accomplished to date.

Required Test and Evaluation Capabilities Assessment (RTECA)

Introduction. The 1996 Defense Authorization Bill, Section 277, directed the Secretary of Defense to develop a 5-year plan to consolidate and restructure the laboratories and T&E centers of the U.S. DoD. The

Office of the Secretary of Defense termed this objective as *Vision 21, The Plan for 21st Century Laboratories and Test and Evaluation Centers of the Department of Defense* (Reference 13). *Vision 21* highlighted how the U.S. DoD planned to restructure, reduce and revitalize the laboratory and T&E infrastructure. The T&E portion of *Vision 21* was led by the Service Vice-Chiefs in their roles as the Board of Directors for the T&E Executive Agent Structure, and subsequently tasked to the T&E Reliance Investment Board (TERIB) to conduct this study.

As one portion of the *Vision 21* effort, the Required Test and Evaluation Capabilities Analysis (RTECA) supported *Vision 21* by identifying the future required T&E capabilities from a T&E perspective. Multiple organizations participated in this process (field, command, headquarters, and contractor graybeards). However, the Tri-Service Reliance Panels conducted the bulk of the effort with limited contractor support.

Objective. The objective of RTECA was to document required T&E capabilities for the near-term (1996 to 2005) and the far-term (2006 to 2020) and to show the linkage of required test capabilities to the documented warfighter needs.

Scope. This was a massive, labor intensive effort involving the three U.S. services (Air Force, Army and Navy) and support from the Joint Program Office for Test and Evaluation (JPO[T&E]). The ramp-up of qualified personnel, composed of service professionals and experienced consultants, in a relatively short timeframe was a significant accomplishment. A new, innovative approach was necessary that required identification and gathering of source documents and the development of tools for research and data collection. The T&E capability requirements were extracted explicitly or derived from the source documents used and then entered into the database. This effort encompassed the fusion of intuitive knowledge from experts across all Reliance Areas of Land Combat, Sea Combat, Air Combat, Space Combat, Armament and Munitions, Electronic Combat, C4I, Targets, Test Environments, and Common Range Instrumentation. The Service's Operational Test Agencies also developed a functional area summary for the RTECA effort as it applied to Operational Test and Evaluation. The first priority of the RTECA effort was to address the focus areas of the *Vision 21* T&E Study Plan: Air Combat, Space Combat, Armament/Munitions, C4I, and Electronic Combat. The remaining focus areas (Sea Combat, Land Combat, Common Range Instrumentation, Targets, and Test Environments) comprised the secondary priorities of the RTECA effort.

Process. The Reliance panels and expert consultants defined the structure for identifying T&E requirements. This structure provided a method to document the required T&E capabilities in a manner identifiable within the T&E community. Although this structure was to apply to all the Reliance Areas examined by the RTECA study, there were some inconsistencies between panels on how they used this structure. This structure was simply:

- Reliance Area
 - Physical Characteristics
 - Technical Characteristics
 - Types of Test
 - T&E Capability Characteristics
 - Attributes
- Human Characteristics

The physical characteristics was exactly that, size, shape, etc. For the technical characteristics, the team developed and defined types of tests, T&E capability categories and attributes to describe test capabilities required by the T&E community in order to assure the needs of the warfighter were met. They then grouped, organized, and inserted these types of tests, T&E capability categories, and attributes into a database under which T&E capability requirements would subsequently be entered. The human characteristics were the requirements for personnel in reference to experience, skills, etc.

The JPO(T&E) researched, collected, and provided the focus area teams with a compendium of over 300 available source documents, which identified concepts, systems, and technologies to meet the needs of the warfighter. The focus area teams supplemented these documents with other program-specific planning documents such as Mission Need Statements, Operational Requirements Documents, Program Management Directives, and Test and Evaluation Master Plans. In deriving the required T&E capabilities, the RTECA team members fused the information from the available documents with their own expert knowledge of warfighter requirements and T&E technologies. Reliance Area panels identified major war fighting systems, which would likely employ these technology drivers and subsequently distilled, primarily by intuition, major T&E capability requirements believed to be of significance. These specific T&E capabilities necessary to test and evaluate systems fielded or likely to be fielded were entered into the database, linked directly to source documents. This database was the primary product of the RTECA effort.

Limitations. Despite the significant effort and resource expenditure by the JPO(T&E) and the Reliance teams

prior to the document review and data collection effort, there were significant limitations and impediments with the RTECA process. Examples of some limitations are provided here to help put the results of this effort in perspective.

- Lack of critical program documents/lack of classified documents
- Insufficient time to accomplish study
- No prioritization of identified requirements
- Varied level of detail on requirements based on document source
- Information organization/taxonomy sub-optimal
- Minimal analytical ability from database
- Lack of guidance/intended use of the resultant database
- Impact potential of new technology on required new test capabilities not addressed

Summary. In general, the purpose behind RTECA was good, but the actual process of developing the database was flawed. The product of RTECA, the nearly 14,000 records in the RTECA database, documented a large percentage of the T&E capability requirements. However, the teams did not consider RTECA to be a 100-percent solution, but an important first step to tie required T&E capabilities to warfare requirements. It is clear that RTECA was a process with significant future utility. The RTECA requires some evolution in order to become a more useful tool to provide a user link from warfighter needs and technology drivers to required T&E capabilities.

The U.S. DoD should use caution when attempting to make reduction, restructuring, and revitalization decisions based on this database. The limitations of the database, previously mentioned, should be considered, as well as the probability that there will be programs, either classified or not yet identified, which will drive significant technological changes to our required tri-service T&E capabilities. The database, derived primarily from current programmatic documents, is perishable in nature. While it is probably adequate for aiding near-term *Vision 21* decision making, unless updated, this database should not be used to define T&E range and facility investments in the out-years.

Annual Planning and Programming Guidance (APPG)

Introduction. The USAF long range plan provides for two end states for the T&E community to achieve. They are:

End State 1: A T&E infrastructure that maintains core USAF T&E expertise in all five T&E

mission areas (aircraft/propulsion/avionics, electronic combat, space, armament/munitions, and command/control/communication/computers and intelligence) at a reduced cost. The infrastructure need not be USAF owned and the USAF should eliminate any unnecessary overlap and redundancy with other DoD, Federal and/or commercial test facilities. This will be achieved by the year 2005.

End State 2: Use of test validated modeling and simulation, along with field testing, will be a key element in evaluating performance/effectiveness, suitability, and life cycle sustainment. This will be achieved by the year 2015.

Objective. A team of planners from the Single Face to Customer test center and headquarters offices was formed to create a T&E modernization working group. This T&E modernization working group was tasked to develop the portion of the USAF Annual Planning and Programming Guidance (APPG) dealing with the modernization requirements to accomplish the two T&E end states.

Scope. The T&E modernization working group looked out to the year 2025 to determine types of test capabilities required to support weapons testing. This required reviewing the long range planning and vision documents that the USAF had produced in recent years. Using the T&E expertise represented on the working group, a timeline for when a T&E capability would need to come online, and a rough order of magnitude of cost for that capability were developed. The T&E modernization working group incorporated this interpretation into the APPG and the USAF long-range plan.

Process. The T&E modernization working group used a multi-step process in developing the T&E USAF Long Range Modernization Plan for the two end states. As step one, the working group performed a documentary scan of the environment in which USAF T&E will operate within the near- (2000 to 2005), mid- (2005 to 2015) and far- (2015 to 2025) term timeframes. The first items reviewed were National and USAF military strategy with a vision of providing global power and reach through air and space superiority, global attack, rapid global mobility, precision engagement, information superiority, and agile combat support. The scan thus addressed initiatives within the acquisition reform process, which T&E supports, such as acquisition cycle time reduction, life cycle cost reduction and weapon system technology protection. The group also reviewed visionary documents defining the USAF of the future, such as *New World Vistas* and

AF 2025. Finally, the scan addressed initiatives/policies mandated on the T&E community by its stakeholders, such as: guidance that the USAF must lead/own its core T&E capabilities, while at the same time reducing infrastructure and T&E budgets; guidance that T&E must rely more on modeling and simulation, hybrid test capability resources, and electronic linking of test locations; and guidance for outsourcing/privatization of testing. From this scan, a vision for USAF T&E modernization that encompasses the two T&E end states was created:

Vision

Provide an integrated T&E complex without geographical boundaries that provides a national capability for T&E of air and space weapon systems utilizing world-class facilities within government and commercial sectors.

The vision recognized that the USAF must rely on other government and commercial sector test capabilities when appropriate so that unnecessary modernization/duplication of USAF T&E infrastructure will not occur.

Step two, from this vision, was development of five modernization strategies to provide an overarching framework to guide T&E investments in the future. These T&E Strategies were: grow constructive and virtual capabilities (modeling and simulation); sustain core T&E capabilities; reduce cost/improve efficiencies; exploit existing assets to meet new T&E requirements; and pursue technology for T&E innovations.

The T&E strategies recognized the increased significance of modeling and simulation and linking geographically separated facilities. The strategies also provide for maintaining/sustaining that "core" infrastructure envisioned being required through the year 2025 and vital to development and sustainment of U.S. DoD systems. In addition, the strategies recognize that with decreasing budgets for T&E modernization accounts, plus decreasing test budgets in weapon system development programs, testing must become more affordable through cost reductions and improved business/engineering practices.

In step three, the group developed a time-phased roadmap of future T&E investments in alignment with these five strategies. This roadmap was baselined on the current near-term investments/program developments, projections of future (mid- and far-term) weapon system development programs and their associated technology drivers.

The last step for the modernization working group effort was development of a rough order of magnitude estimate for funds required to support the USAF T&E roadmap. The near-term funding profile reflected the current modernization efforts underway. Recommended mid-term investments captured funding required to sustain core T&E capabilities, an increase to modeling and simulation capabilities to meet T&E end state 2, and funds to prepare the USAF to test the weapon concepts that were forecasted for the mid- to far-term timeframe. Far-term investment profiles for the five strategies reflected that major investments would have to be made in the mid-term timeframe and that the investments in the fiscal year 2015 to 2025 timeframe were for sustainment of those capabilities and identification of those new technologies in beyond the far-term.

Limitations. The primary limitations to this effort were the short time period to accomplish it and the lack of an established process for inputs. An in-depth look into requirements was not possible. Earlier one-time efforts such as RTECA and the MSP were used as inputs on T&E requirements. The lack of an established process to provide T&E interpretation of higher level guidance or to provide warfighter and science and technology requirements and thus, T&E requirements, heavily impacted the validity of the modernization working group's efforts.

Although the modernization working group developed a macro-level long-range T&E roadmap as a product for this study effort, the group realized that this was just a start for what is required to meet the two defined T&E end states in the desired timeframe. There was agreement in that the pursuit of these end states would provide the USAF with an evolving capability to evaluate new and existing system's performance in a more cost effective and timely manner. However, the USAF T&E community cannot achieve these end states in isolation. There must be a commitment on part of the USAF, in partnership with industry, to invest in T&E capability. To avoid duplicating existing T&E capabilities at contractor locations, the USAF must be aware of planned and existing contractor T&E capabilities (insight into industry planning currently does not exist). The working group recommended establishment of a formal and enduring process to partner with the private sector in long-range investment planning.

Summary. The strategic area emphasized least in the near-term is in development of new test technologies. Based on the limited documentary scan, the USAF should invest in test technology development focusing

on areas where test capability is seriously insufficient. These investments are necessary to allow study of the requirement for new test technology, versus actually developing the capability. Actual development would occur in the mid- or far-term. While investments in these areas can be debated, they should be based on common threads from all of the long-range planning documents reviewed as part of a formal process.

The majority of the investment dollars in the mid-term will address T&E required for the next generation weapon systems. Mid-term investments are based on predictions that the USAF is evolving from an "Air and Space Force" into a "Space and Air Force." These investments are dependent on having previously invested in test technology development in the near-term timeframe and will impact future investments for the far-term.

Investments for the far-term are the modernization working group interpretations of T&E requirements based on historical T&E investments and limited review of visionary documentation. Predictions are that modeling and simulation will remain a large portion of T&E and by the far-term may consume a larger portion of the investment budget. The far-term will require consistent refocusing, as new forecasts of future requirements become available.

In general, in the near-term, the requirements are very well defined, while the focus becomes less clear in the mid-term, and turns into a fog for the far-term. The focus for the future should be on the mid-term requirements, as this is the area we can impact the most. As the mid-term timeframe approaches, the fog should begin to clear on those far-term investments now defined, while new far-term investments are identified.

Test and Evaluation Requirements Assessment Team (TERAT)

Introduction. With the results of the above study efforts and evaluations in hand, senior USAF leadership realized that there was still a missing part to the puzzle of "right-sizing" the T&E infrastructure, the program directors perspective. The T&E community completed all of the previous efforts looking at T&E requirements and the results are from their perspective. It became obvious that to make the best decisions on the future of the USAF T&E infrastructure, the systems acquisition community needed to provide their perspective to the future T&E requirements picture.

The Test and Evaluation Requirements Assessment Team (TERAT) is an ongoing effort designed to provide both the systems acquisition and T&E communities' perspectives on the future requirements for T&E

capabilities. As in previous studies, multiple organizations are participating in the process. The biggest difference is that this effort is co-sponsored by the USAF Secretary of the Air Force Acquisition Chief (SAF/AQ) and the USAF T&E Chief (AF/TE). In addition, a general officer from the USAF acquisition community is in charge of the team, thus truly putting the focus on the acquisition side of the equation. The key products of this study effort are a comprehensive list of USAF Programs (with points of contact), a maturing database of test requirements, data query tools, and some data analysis for the "decision makers."

Objective. The objective of TERAT is to assess and document T&E capabilities and capacity required for USAF modernization now through the year 2010.

Scope. As with the previous studies, TERAT is a massive labor-intensive effort. The use of the knowledgeable mission area experts from the RTECA study has been crucial to the success of this effort. The TERAT is limited to the USAF at this time, but may eventually expand to include all three U.S. services (Army, Air Force and Navy). TERAT has the luxury of learning from and applying concepts used in previous studies. Specifically, TERAT utilized to a great extent the methodology developed for RTECA in the development of the tools and structure for research and data collection. The T&E capabilities requirements (TECR) methodology, based on portions of the RTECA effort, was the foundation for TERAT. As with the MSP effort, the following mission areas were the focus of the effort: Aircraft-Propulsion-Avionics, Armament-Munitions, C4I, Electronic Warfare, and Space.

With the focus of the TERAT effort on the acquisition side of the equation, a large part of the effort was developing a list of all USAF programs, to query and acquire data from, on T&E requirements. This effort alone was, and still is, a huge task, not because of the large number of programs, but to ensure capture of 100 percent of USAF programs. As of this date, nearly 450 weapon system acquisition programs are a part of the overall TERAT database.

Through the use of the T&E capabilities requirements-based methodology, a data query was sent to these programs and data received back from nearly all of them. One of the key items discovered in completing this data call was that the program managers needed more information on specific T&E capabilities that they could reference to meet their needs. In a TERAT follow-on effort, a data call to T&E facility/capability managers requested specific information on test capabilities that will be made available to the program managers. As part of this TERAT follow-on effort, a second data query will be sent to the program managers

with the goal of getting them to provide very focused future T&E requirements down to the facility level.

Process. TERAT is a two-phase effort. Phase I included the adaptation of the T&E capabilities requirements-based methodology to the specific goals of TERAT, development of a target list of programs to query, and the actual data call to these programs asking for their T&E requirements. Phase II consists of refinement of the data query tools, a data call to the facility/capability managers, and a second data call to the program managers for T&E requirements to the facility level.

Throughout the entire TERAT process, the mission area experts, representatives from SAF/AQ, AF/TE, Air Force Materiel Command, and the ANSER Corporation have been developing and refining the study structure. Currently the structure is:

- Program
- Mission Area
- T&E Capability Requirements
- T&E Resources Category (Digital Modeling, Ground Test, Open Air Range)
- Source (Air Force, Army, Navy, Commercial, Foreign)
- Facility/Asset/Capability Class
- Facility/Asset/Capability
- Demand (Months)

This structure represents the hierarchy and outline for the database that forms the basis for the entire TERAT effort. The designed structure allows the individual program manager to work his/her way down by selecting the appropriate category under each major area. The specific test facility/capability information is available in the facility/asset/capability category and at this point the program manager can identify future T&E requirements for his/her program. Multiple paths and entries are acceptable and encouraged to ensure maximum capture of all T&E requirements.

Limitations. Again, as with the other studies, despite the significant effort and resource expenditures, there are numerous limitations and impediments to the TERAT process. The major limitations are:

- Very high level look - some programs and requirements overlooked
- Current program focus limits long-term T&E requirements identification
- Concurrent survey process and analysis development
- Possible duplication of inputs
- Short timeframe to complete effort compromises data quality and completeness

- Limited capacity for response review
- Data not thoroughly reviewed before entry into database
- Software application and survey tool shortcomings
- Program target list incomplete and difficult to manage

Summary. The TERAT certainly has accomplished its goal of identifying T&E requirements for the near- and mid-term out to the year 2010. With the focus on identifying these requirements from the consumer (acquisition/program) perspective, TERAT has tremendous credibility. However, as with the other studies, TERAT is not the complete solution. Taken with the other studies, these efforts are closing in on providing the complete picture to the "decision makers" on what the USAF and U.S. DoD T&E infrastructure should look like. TERAT is a "tool" that is still evolving and will most likely be instituted as a yearly or once every 18 month process to help in the T&E infrastructure investment process.

The danger in TERAT is the use of this data to make major T&E reduction or investment decisions. With the limitations previously identified, the probability of making the best decision based on this data is not very high. In addition, the "right-sizing" decisions for the T&E infrastructure must look out beyond the year 2010 for which TERAT is limited to.

The TERAT has provided a tremendous snapshot and analysis of T&E requirements. This effort must be integrated with the futuristic projections as mentioned earlier in this paper as well as the future warfighter requirements. Only then will a clear picture be developed that will allow for the major T&E reduction and investment decisions to be made with a high level of confidence.

Proposed New Process

The four studies discussed above show the USAF has been working diligently for the past several years to identify T&E capability requirements in preparation for the 21st century. However, as can be seen from these discussions, there is no single process for T&E capability requirement or test technology needs identification in the USAF. There needs to be a formalized test technology needs identification process to provide for integrating existing and future warfighter requirements and strategic guidance into identifiable T&E capability requirements, which in turn, would allow for identification and discussion of new test technology needs for 21st century USAF T&E.

We do not necessarily propose that any of the discussed studies should or should not be retained in their entirety

as parts of the new process, nor do we attempt to state whom should carry out any or all of the elements of this notional process. However, our process may incorporate portions of previous methods used during some of the discussed studies if they appear to fit within the process and were considered successful. Our objective is merely to outline a conceptual process (Figure 14-1) for providing a systematic approach to T&E capability requirement and test technology needs identification. This process is designed around the basic “strategy-to-task-to-need-to-solution” approach as outlined in our USAF Modernization Planning Process. In the “strategy-to-task” portion of the process, we have basically two elements: technology push/warfighter pull and T&E synthesis/linkage. The technology push/warfighter pull element is fairly well established. The Major Commands identify their warfighter requirements and deficiencies in their Mission Area

Plans based on the strategic visions and guidance as previously discussed. The Science and Technology community then prepares their Technology Area Plans identifying their proposed technology roadmaps based on these warfighter requirements and deficiencies and potential technological applications. This process is currently accomplished by Technology Planning Integrated Product Teams (TPIPTs) chaired by Product Center² long-range planning personnel and including personnel from the research laboratories, operational community, air staff, logistics, finance, intelligence, and test community. However, the output of the TPIPTs does not include identification of technology roadmaps for test capability requirements, only for warfighter requirements. Therefore, the USAF needs to formally implement the second element in the “strategy-to-task” portion of the proposed process, T&E synthesis/linkage.

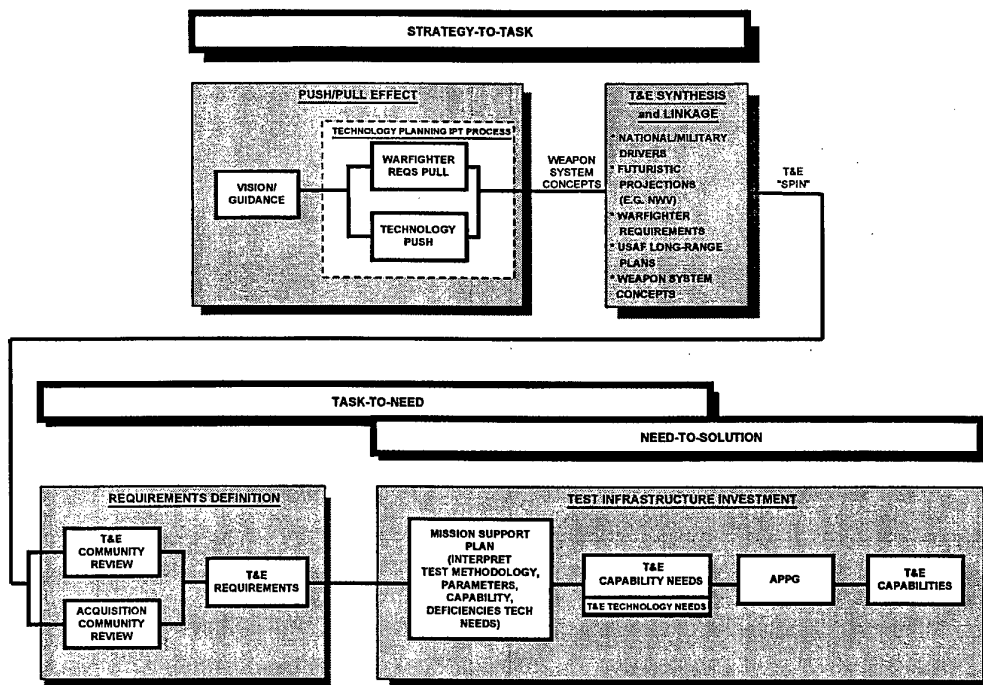

Figure 14-1. Notional T&E Requirement and Test Technology Needs Identification Process

² Aeronautical Systems Center (ASC), Electronic System Center (ESC), and Human Systems Center (HSC)

The T&E synthesis/linkage is basically an interpretation of the information obtained from the push/pull element of the strategy-to-task portion of the process. A common theme from the recent studies was the need to interpret or synthesize the higher level visionary documents and long-range plans. Few of the visionary documents or long-range plans previously discussed address T&E specifically (*New World Vistas* being the exception). The T&E community needs to formalize this portion of the process to develop a recurring review of these types of documents to provide planners the information required to accomplish strategic planning for T&E. Several of the studies discussed in this paper attempted some form of interpretation of these types of documents, but with limited scope, time, and resources. Establishment of a formal group to accomplish this task routinely as part of the T&E modernization planning process is mandatory. Accomplishing this type of review/interpretation on an ad-hoc basis does not provide the consistency and continuity required of a strategic planning process. In order for this "strategy-to-task" phase of the proposed process to work, sufficient time must be provided to collect, review, analyze and report on the interpretation/synthesis of this tremendous amount of information.

The next phase of the process, task-to-need, develops the actual T&E requirements (i.e., what T&E tasks we need to accomplish). Two of the studies we participated in, RTECA and TERAT, were good attempts at defining T&E requirements from the T&E community and acquisition community. Neither community has all the answers when it pertains to required testing. The testers are viewed as wanting to overkill the testing required, and the acquisition community is viewed as wanting to accomplish little or no testing to save costs. Collectively though, they can identify the anticipated T&E requirements. By matching their inputs, the strategic planners can get the entire picture of where we need to go in the 21st century. As with the previous phase of the process, a formal group needs to be established to direct these two efforts. While neither RTECA nor TERAT were considered the best example of how to accomplish the task, the ideas behind both were sound. This phase must have two concurrent efforts (a T&E team and an acquisition team) to take the synthesized information from the "strategy-to-task" phase and determine T&E requirements from their perspective. These requirements would then feed into the next phase, "need-to-solution."

The "need-to-solution" phase starts with the input of T&E requirements developed by the T&E and acquisition communities. These requirements are the tasks we need to accomplish. This phase will determine how we solve those needs. The MSP study was a fairly successful effort, though it lacked the input required to make it a fully successful plan. The synthesis of

information from the "strategy-to-task" phase through the "task-to-need" phase of our proposed process provides a valuable input into the MSP. The process for development of the MSP is standardized by the USAF, but the quality of the product is not. The MSP effort would interpret the T&E requirements into how we would test, what parameters we need to measure, etc, and determine what capability is required to accomplish the test. A comparison with existing capabilities would define the T&E capability deficiencies. These deficiencies may include upgrades required, sustainment necessary, or new test technology required. However, up to this point, all of the information provided by the "strategy-to-task" and "task-to-need" phases has been fiscally unconstrained. This means the tasks, needs and solutions defined in the T&E MSP were also unconstrained. Thus, the next step in the proposed process, the Annual Planning and Programming Guidance development. This is an established process for the USAF. *Joint Vision 2010* states "As we implement this vision, affordability of the technologies envisioned to achieve full spectrum dominance will be an important consideration. While we anticipate that some significant improvements in capability may be gained economically, others will be more difficult to achieve within the budget realities that exist today and will exist into the next century. We anticipate the need to be selective in the technologies we choose, and expect continuing assessment and adjustments for affordability as well as for other lessons learned during the implementation process." The APPG places fiscal reality and business practices constraints in the process. These constraints provide criteria for determining what the most important T&E needs are that are affordable. By following these constraints, and improving the source of information flowing through the MSP into the APPG, the APPG becomes a document with increased validity. The result of this entire effort then is identified, affordable, required T&E capabilities and T&E technology needs that will take the USAF into the 21st century.

Summary

The USAF has, and continues to reinvent itself since the Cold War. All commands including the Air Force Material Command have gone through a restructuring to account for reductions in budgets and personnel. As part of Air Force Material Command, the T&E community also is responding to change by evaluating its customers, business practices and processes, as well as setting strategic goals. The T&E community has an obligation to support the USAF vision to provide "Global Engagement" in support of the Joint Chief's *Joint Vision 2010*. As such, the T&E long-range modernization vision and strategic goals are directly linked to the USAF vision for the 21st century. This direct linkage ensures T&E modernization planning is consistent with USAF guidance, command goals and

objectives/plans. Currently, the USAF T&E community does not have a single formalized process for T&E capability requirement or test technology needs identification to ensure this linkage occurs.

The four major studies discussed in this paper show that the USAF has been working diligently for the past several years to identify T&E capability requirements in preparation for the 21st century. However, as can be seen from these discussions, there needs to be a formalized test technology needs identification process to provide for integrating existing and future warfighter requirements and strategic guidance into identifiable T&E capability requirements, which in turn, would allow for identification and discussion of new test technology needs for 21st century USAF T&E. Each of the discussed studies had valuable portions of each of their respective processes.

However, the U.S. DoD should use caution when attempting to make major reduction, restructuring, revitalization, or investment decisions based on the data from these studies/plans. With the limitations identified in each study/plan discussion, as well as the probability that there will be programs, either classified or not yet identified, which will drive significant technological changes to our required tri-service T&E capabilities, the chances of making the best decision based on this data is not very high. These studies/plans provide a tremendous snapshot and analysis of T&E requirements, but because the requirements are based primarily on programmatic documentation, this snapshot is perishable in nature and must be routinely updated. In addition, these efforts must be integrated with the futuristic projections as mentioned earlier in this paper as well as the future warfighter requirements in order to provide a clear picture that will allow for the major T&E reduction and investment decisions to be made with a high level of confidence.

From past experience we realize that the type of efforts such as those discussed in this paper will recur in the near future. Rather than dropping the results of these efforts and starting over with a new effort, we recommend that the USAF T&E community use the lessons learned from accomplishing these studies and develop a singular formalized process such as that presented in this paper. This singular formalized process should provide for integrating existing and future warfighter requirements and strategic guidance into identifiable T&E capability requirements, which in turn,

would allow for identification and discussion of new test technology needs for 21st century USAF T&E.

References

1. "Joint Vision 2010, America's Military: Preparing for Tomorrow," John M. Shalikashvili, Chairman, U.S. Joint Chiefs of Staff, 1995.
2. "Global Engagement: A Vision for the 21st Century Air Force," U.S. Department of the Air Force, 1997.
3. "Defense Science and Technology Strategy," U.S. Department of Defense, Director, Defense Research and Engineering, May 1996.
4. "New World Vistas: Air and Space Power for the 21st Century." Aircraft and Propulsion Volume, Ancillary Volume, Attack Volume, Classified Volume, Directed Energy Volume, Human Systems and Biotechnology Volume, Information Applications Volume, Information Technology Volume, Materials Volume, Mobility Volume, Munitions Volume, Sensors Volume, Space Application, Space Technology Volume, Summary Volume," U.S. Air Force Scientific Advisory Board, 1995.
5. "2025 Executive Summary," Air University, Maxwell Alabama, August 1996.
6. "Basic Research Plan," Office of the Director of Defense Research and Engineering, Washington D.C., May 1996.
7. "Joint Warfighting Science and Technology Plan," Office of the Director of Defense Research and Engineering, Washington, D.C., May 1996.
8. "Defense Technology Area Plan," Office of the Director of Defense Research and Engineering, Washington D.C., May 1996.
9. "AF Policy Directive (AFPD) 10-14, Operational Requirements and Modernization Planning Process," U.S. Department of the Air Force, 3 March 1995.
10. "AF Instruction (AFI) 10-601, Air Force Mission Needs and Operational Requirements," U.S. Department of the Air Force, 31 May 1994.
11. "A National Security Strategy of Engagement and Enlargement," The White House, February 1996.
12. "National Military Strategy of the United States of America 1995: A strategy of flexible and selective engagement," U.S. Joint Chiefs of Staff, 1995.
13. "Vision 21, The Plan for 21st Century Laboratories and Test and Evaluation Centers of the Department of Defense," U.S. Department of Defense, 1996.

DISCLAIMER: OPINIONS, INTERPRETATIONS, CONCLUSIONS, AND RECOMMENDATIONS ARE THOSE OF THE AUTHORS AND ARE NOT NECESSARILY ENDORSED BY THE UNITED STATES AIR FORCE. IN ADDITION, THIS PAPER DOES NOT ATTEMPT TO PROJECT OR ADVOCATE SPECIFIC TEST AND EVALUATION PROGRAMS, INFRASTRUCTURE REQUIREMENTS, OR METHODOLOGIES, SCIENCE AND TECHNOLOGY TECHNOLOGIES, OR ROLES AND MISSIONS

**The Use of Modeling and Simulation in the Operational
Test of Military Aircraft: Promises and Challenges**

Dr D Wiesenhahn and Mr R Dighton,
Institute for Defense Analyses, USA

THE USE OF MODELING AND SIMULATION IN THE OPERATIONAL TEST OF MILITARY AIRCRAFT: PROMISES AND CHALLENGES

David Wiesenbahn and Robert Dighton
Institute for Defense Analyses
1801 North Beauregard Street
Alexandria, Virginia, USA

ABSTRACT

The capabilities of modeling and simulation (M&S) have grown tremendously during the past decade. As M&S matures, defense officials are starting to examine the possibility of using this technology to improve the acquisition and employment of military systems. Potential applications include research, development, and engineering of new systems; test and evaluation; and training. Each of these applications has different simulation requirements that must be understood before simulation development begins, especially since the distributed, interactive, graphics-intensive systems typical of modern simulation programs have historically been developed for training applications. This paper describes the general requirements that operational testers of military aircraft will place on M&S if it is to be accepted by the test and evaluation community. Test and evaluation – and in particular *operational* test and evaluation (OT&E) – may pose some of the greatest challenges to M&S developers, but, because of the limitations inherent in the large field tests characteristic of operational testing, OT&E users could benefit greatly from modeling and simulation to improve their test programs. More work needs to be done in M&S development, and the challenges facing the M&S community are discussed in this paper.

INTRODUCTION

In one form or another and in a wide variety of applications, modeling and simulation (M&S) has long been used by the military. Consider the first flight simulators, built during World War II to train pilots quickly, while at the same time reducing the amount of expensive flight training required to graduate qualified pilots. Or consider the development of the first digital computers, which were used to model lethality of nuclear weapons and to calculate ballistic missile trajectories.

More recently, over the last decade or so, great strides have been made in computer networks and

graphics capabilities, pulled along by the ever-steady rise in computational power and speed and mirrored by an equally rapid decrease in cost for these capabilities. At the same time, defense budgets have been declining, forcing all aspects of military operations and procurement to reduce costs. To alleviate the budgetary pressure, many military departments around the world have turned to M&S as a means to do more with less money, and whole new opportunities for computer-based M&S have arisen.

Despite the potential that M&S holds, it is not the panacea for every situation. Indeed, it is only a tool that should be used judiciously.

This paper discusses the use of M&S in the operational test and evaluation (OT&E) of aircraft – the promises and the challenges. OT&E is only one part of the acquisition process, but it is one that historically has not enthusiastically embraced M&S. Although this paper focuses on OT&E of aircraft, the observations and conclusions in this paper should apply to the broader topic of using M&S in any test application, and should not necessarily be limited to military programs.

USER DOMAINS

One of the first things to recognize is that not all users of M&S are the same. Different users will generally place different requirements on M&S, and these must be considered carefully when considering the use of M&S. One user may require a man-in-the-loop (MIL) simulation with high-resolution visual graphics running in real time, while another user might require a highly credible, physics-based model that does not have to run in real time and does not require a graphical display. In other words, a model or a simulation developed for one user and application may not be suitable for another user with a different application.

There are several ways to delineate military user domains. The Simulation Interoperability Standards Organization (SISO), an international

group developing M&S standards,¹ has defined five categories of military user domains, and uses this taxonomy in their semi-annual Simulation Interoperability Workshop (SIW):

- **Analysis:** This domain uses M&S to conduct a wide range of studies, including strategy, tactics, and policy studies; logistics analyses; trade and early concept explorations and feasibility studies; and safety investigations.
- **Research, development, and engineering (RD&E):** These users typically employ M&S early in the acquisition process for preliminary designs, trade studies, Analysis of Alternatives (AOA)² studies, and manufacturing feasibility analyses.
- **Small-unit training:** This domain includes individual, subteam, and team training to system operators, team leaders, tactical decision makers, and other hands-on users.
- **Staff-level training:** This domain includes decision-makers who are planning and managing the activities of groups of people and other resources, and uses M&S for the training of operational and strategic leaders and their staff.
- **Test and evaluation (T&E):** These users assess system performance against requirements or specifications, and use M&S later in the acquisition process, typically after Milestone II, the entry into Engineering and Manufacturing Development.

Taken together, these domains represent the complete cradle-to-grave history of a weapon system. During concept development, analyses are performed to determine the viability and cost effectiveness of various approaches. As the design matures and manufacturing begins, more detailed RD&E design studies are performed. Before the system is fielded, T&E is completed to ensure that the system as built is still effective. Once the system is fielded, operators must be trained, and further analysis is done to determine the best way to employ and sustain the system.

These domains are roughly independent, although there is some overlap. For example, the point at which analysis ends and RD&E takes over is not distinct. Likewise, there is also some overlap in the requirements that each domain will place on M&S.

It is important to understand the users so that simulations can be tailored to meet the unique requirements of each domain. A simulation developed for, say, staff-level training, will not necessarily meet the needs of the analysis community without modification.

CASE STUDY OF M&S REQUIREMENTS: TRAINING vs. TEST AND EVALUATION

To illustrate how different user domains might have different requirements for M&S, we will compare some general M&S requirements of two of these communities. The training community is a good starting point since much of simulation's roots is in the training community. Although the M&S industry is trying to branch out to other user domains, it is still arguably dominated by the military training commands. Teaching pilots to fly during World War II was one of the first uses of simulators that used motion and other cues to improve realism. Flight simulation has remained on the leading edge of simulation technology, but other training applications have also driven simulation technology. For instance, exercises on a scale large enough to train staff-level commanders are too expensive actually to perform in the field, but they can be simulated through networked computer simulations, and have provided some of the motivation for linking distributed simulations.

The primary goal in training is to transfer positive skills to the student. Numerous studies have been conducted to determine what qualities of training and simulation lead to optimum transfer. A review of these studies is beyond the scope of this paper, but some generalities can be drawn concerning the use of simulators in training.

Since it is a human being trained, training applications often require human interaction with the simulation, which, in turn, dictates that most or all of the simulation must run in real time. Many MIL simulations also require high-resolution visual displays to recreate faithfully what the trainee would see, and many trainers use force and audio cues to increase realism. For many training applications, it is important to simulate the operational procedures accurately so that the student can learn the proper sequence of events to perform. However, other aspects of the simulation do not necessarily need to be simulated accurately, and it may in fact be beneficial to add some artificiality. For example, a pilot may never experience loss of an aircraft engine, but it is obviously helpful to practice this situation numerous times in a flight simulator. In general, it is not an *a priori* requirement to model the physics

¹ See <<http://www.sisostds.org/>>.

² This was formerly called the Cost and Operational Effectiveness Analysis (COEA).

of the processes faithfully, as long as the trainee is immersed in an adequately realistic environment that leads to positive skills transfer.

On the other hand, the purpose of T&E is to evaluate certain performance characteristics of the system under test. Since T&E is fundamentally a measurement technique, the *accuracy* of the evaluation is an overriding concern.

An inaccurate T&E assessment could lead to incorrect production decisions, potentially wasting acquisition funds and fielding inferior or unsafe systems. As desirable as it is to achieve high accuracy, quantitatively calculating accuracy for an operational test program can be difficult, if not impossible. General analytic expressions based on measurement theory can be formulated,³ but since these rely on a functional description between the measurements and the independent variable or subordinate processes (including any models), these are impractical for OT&E. However, an important qualitative result from measurement theory is that

the accuracy of the final measurement is in general no better than the worst subordinate error.

What does this have to do with modeling and simulation? If we view M&S as a tool that can be used to evaluate the system – a subordinate process, in effect – then the accuracy of the overall evaluation will depend on the accuracy of any model or simulation used in a test program. If a model or a simulation with poor accuracy or credibility is used in a key part of an evaluation, it will inordinately degrade the overall accuracy of the final evaluation. Of course, this doesn't just apply to simulation, but applies to the entire OT&E program.

OPERATIONAL TEST AND EVALUATION

Two laws⁴ were passed in the mid-1980s to create the office of the Director, Operational Test and Evaluation (DOT&E) and to formalize the role of OT&E in the acquisition process. These laws state that:

a major defense acquisition program may not proceed beyond low-rate initial production until initial operational test

and evaluation of the program is completed.

Congress defined operational test and evaluation as follows:

“operational test and evaluation” means – the field test, under realistic combat conditions and may not be ... based exclusively on computer modeling [or] simulation

These laws force major military systems to be tested by an independent agency in realistic, warlike situations with real operators. They are intended to prevent purchasing systems justified solely by paper or computer studies, or only by sterile, laboratory tests. By placing systems in stressful situations before production begins, flaws can be discovered and corrected before the system is bought and fielded. If the system had too many flaws, or if the system met all of its technical specifications yet was still not effective in the field, the program could be terminated before investing large amounts of money in full-rate production. There is also the perception that field tests are more honest and less susceptible to political manipulation than models or simulations. Thus, the operational evaluation provided by DOT&E allows the Milestone III Full Rate Production decision to be made with higher confidence and with less risk.

Although the law was intended to emphasize field-testing, Congress clearly allows DOT&E to include some modeling and simulation in its evaluations. Congress recognized that field testing by itself cannot permit a complete and perfectly accurate evaluation, and that there is a role for analysis above and beyond the results obtained in the field.

Recall earlier that it was asserted that since OT&E essentially measures the performance of a system, then it is of paramount importance that this measurement be accurate. For OT&E, accuracy is defined as:

obtaining an evaluation of performance from the test program that is close to the level of performance that would be obtained in an actual wartime situation.

According to this definition, the most accurate method of measuring performance of a military system is to place it in an actual war (and indeed, this is why Congress created the operational-test laws described above), but, of course, this is not practical. Field tests can be made to approximate wartime scenarios, but the maxim that “anything short of war is a simulation” is true.

³ “Accuracy in DoD High Level Architecture Federations,” Lester Forster, paper 97F-SIW-064 presented at the Fall 1997 Simulation Interoperability Workshop (see footnote 1).

⁴ 10 USC § 139 and 10 USC § 2399.

MEASURES OF EFFECTIVENESS FOR AIRCRAFT OT&E

Besides the test environment itself, the measures used to characterize system performance also play a key role in developing the operational test program. For OT&E, these measures of effectiveness (MOEs) are divided into two categories – operational effectiveness and operational suitability. The former describes how well the system performs its intended mission, while the latter characterizes the ability to which the system can be used in its intended application.

MOEs used in OT&E are generally at the mission level (i.e., they describe the outcome of a mission). They can also be at a higher, campaign level, but MOEs at the lower, engagement are also used in OT&E. There is no established guidance that dictates the level that should be used, and, indeed, there may be inconsistency among programs and services. One factor in determining the most appropriate level is how the Operational Requirements Document (ORD)⁵ specifies requirements for the system. Another important consideration is the AOA: since the AOA justifies the start of procurement, it is logical to use the test program to confirm the predictions made in this study.

Measures of operational effectiveness depend on the role of the system being tested. For fighter aircraft that have the role of destroying enemy aircraft, an effectiveness MOE might be the loss-exchange ratio, which expresses the ratio of enemy and friendly aircraft killed in a specified time, such as over a mission or over a campaign. For strike aircraft, an appropriate measure could be the ability to penetrate enemy air defenses and deliver the ordnance accurately to the target. Useful measures for surveillance aircraft might include detection range, or the number or percentage of targets detected. Measures that have been used to evaluate transport aircraft include million-ton-miles per day (MTM/D) of cargo transported, and closure time to airlift a military unit. These measures are summarized in Table 1.

Besides these effectiveness measures, every aircraft procured has operational suitability requirements that it must meet. The requirements that usually receive the most attention are those concerned with reliability, maintainability, and availability (RM&A). At the highest level, most aircraft will be required to maintain a sustained,

high-tempo level of operations that might be expected in wartime. This capability can be measured in terms of sorties per day (typical of fighters), utilization rate (transports), or on-station availability (surveillance aircraft). Other requirements may specify the maintenance demands and the reliability of the aircraft and its systems. Examples of these include maintenance man-hours per flight hour (MMH/FH), mean repair time, and number of maintenance actions per flight hour.

Besides RM&A requirements, there are often other important suitability requirements. These might include interoperability between other similar assets (increasingly important as newer systems are fielded with more command and control capability and are expected to participate in such networks), interoperability with other service's platforms and systems, and logistics support including spares provisioning, training equipment and planning, and depot repair support.

Some of the highest-level measures can combine both effectiveness and suitability measures. These are usually campaign-level measures, which might include the same effectiveness measures described above but – rather than for just one mission or sortie – for an extended period of time. For example, for a bomber aircraft, the relevant campaign-level measure might be the number of targets destroyed during a month-long campaign. Such measures are attractive for several reasons. One is that they combine both operational effectiveness and suitability measures. Another is that measures of this level are often used to justify procurement in the AOA. Finally, measures at this level are an intuitive way of communicating overall performance to decision-makers.

THE PROMISE FOR MODELING AND SIMULATION

Now that we have defined the desired operational test environment and the performance parameters we need to obtain from the test program, we can discuss our ability to achieve these goals. If we are unable to measure all of the desired MOEs completely in the stressing wartime environment through flight testing, M&S may be able to fill in some gaps and improve the operational assessment.

Constructing realistic operational tests might sound easy, but when the innumerable details are considered, it becomes apparent that creating a highly realistic test environment can be challenging, especially for aircraft. Some of the

⁵ The ORD specifies what the user of the system requires of the system.

Table 1. A Sampling of Engagement and Mission-Level Effectiveness MOEs for Tactical Aircraft Programs

Mission	Aircraft	Mission-Level Measures
Strike	F/A-18E/F JSF	Number of strike aircraft reaching weapons release point Number of sorties required to destroy a specified target Number of aircraft lost destroying a specified target
Air superiority	F-22 F/A-18E/F JSF	Exchange ratio (defined as the number of enemy aircraft lost divided by the number of friendly aircraft lost) Dominance (defined as the number of trials in which 50% of the opponents were killed) Percent of trials in which high-value airborne assets are killed
Strategic transport	C-17	Million-ton-mile/day (MTM/D) capacity Throughput vs. airfield size, tons/day Time and sorties required to deploy a specified unit
Tactical transport	C-17 C-130J V-22	Throughput vs. airfield size, tons/day Time and sorties required to deploy an airborne unit Tons/day deliverable vs. sortie radius Time required to airlift an air assault element of a marine expeditionary brigade ashore (V-22) The reduction in time (compared to existing systems) required to evacuate 50 casualties from a combat zone (V-22) Probability of successfully completing a special operations infiltration mission in a moderate air-defense environment
Surveillance	JSTARS AWACS	Timeliness, accuracy, and completion of delivering detection reports (JSTARS) Fraction of hostile aircraft detected before weapons release (AWACS)

limitations encountered in the operational test of aircraft include:

- **Threat replication:** Flight testing against actual enemy systems (including aircraft, missiles, radars, and infrastructure), operated by enemy crews, does not occur. Exploitation of foreign systems, when it does occur, is usually limited to only a handful of systems, insufficient to conduct a meaningful operational test.
- **Force density:** There are many systems that might be present and relevant during an actual air-combat sortie: escort aircraft, strike aircraft, jammers, tankers, surveillance aircraft, ground radars, and command-and-control networks. It is costly and complex to have all relevant systems participate in a flight test.
- **Kill assessment and removal:** In a flight test, no one actually dies, and systems are not usually destroyed. Thus, something that was supposedly killed in a test will still exist and may remain as a shadow factor in the mind of the operator or in the system itself (e.g., radars or other sensors). Such residual presence must be artificially overruled.
- **Safety:** Missiles and guns cannot be fired at aircraft, even if the missiles contain inert warheads. Night and low-level flying is also usually restricted.
- **Range space:** Instrumented range space is limited in the United States, which could impose an artificial barrier to systems under test. Fighter and strike aircraft are usually capable of supersonic speeds, which in turn require more expansive ranges. Pilots must always be aware of where they are in relation to the range boundaries.
- **Expense:** Flight testing is expensive. For even a modest few-on-few engagement, 20 or more aircraft could be required to be airborne when all support aircraft are considered. Wartime conditions imply a high tempo of operations to assess operational suitability. Multiple trials, consisting of repeated runs for statistical confidence or for exploring different scenarios, are desirable, further compounding the expense. Maintenance, logistics, and support costs can also be considerable.

Because of these limitations, direct flight testing cannot directly assess all of the MOEs typically desired from OT&E of aircraft. Each of the limitations described above presents an opportunity for M&S to improve the operational evaluation of the system.

Consider the first two limitations described above: threat replication and force density. Simulations running concurrent with the test can simulate many of these features. A threat can be replicated artificially by an off-board simulation and injected into the aircraft; if this stimulation occurs just after the sensor, not only can the pilot be led to believe that the threat is present, but the signal-processing algorithms of the aircraft can also be evaluated to ensure that they properly process the threat. If enough threats are simulated in this manner, the threat density can be increased to simulate a larger, stressing engagement. The ability of both the operator and the sensor-fusion algorithms to process large amounts of information is becoming more important in modern aircraft, and thus simulation could play a large part in evaluating this capability.

The next two considerations are kill assessment and removal, and safety limitations preventing the firing of missiles and guns. Both of these limitations can be somewhat mitigated with simulation. Missile flyouts can be simulated, and a miss or kill can be based on a random draw if the missile gets close enough to the target to fuse. If the target is killed, simulation can also be used to artificially suppress the display of that target on the other pilot's displays. Indeed, if the air-combat battle remains beyond-visual range (BVR), the only knowledge a pilot has of enemy aircraft is through his display; if this is controlled completely by the simulation, then theoretically the information presented to the pilot in this test-simulation hybrid would be the same as an actual wartime engagement.

Adequate test range space is becoming an increasing problem as aircraft, such as the F-22, acquire supercruise capability. Tests conducted at supercruise conditions exceeding Mach 1.4 for periods exceeding 15 minutes (routinely practical without afterburners) will cause the aircraft to exceed the existing test range boundaries of Edwards, Nellis, and Eglin Air Force Bases. Although it has been proposed to link the ranges at these Air Force bases at high altitudes (above commercial airliner altitudes) to support these supercruise tests, this proposal has not been approved (and likely will never be approved) by the Federal Aviation Authority.

The final limitation listed above is cost. The potential for M&S to alleviate some of the high cost of testing is discussed in more detail later in this paper.

Notice that, in the examples cited in this section, M&S is integrated into the flight-test program. This is an important observation, since too often planners approach flight testing and M&S as opposites. This leads to a partial decoupling of flight testing and M&S, and may result in a test program that consists of distinct modeling and test phases, e.g., the "model-test-model" approach. There is nothing inherently wrong with this approach, but it can relegate the role of testing to merely providing data for model validation, and it does not take advantage of the possible synergism between modeling and simulation. This synergism was illustrated in the examples cited above.

There are, of course, times in OT&E where the use of M&S is not necessarily integrated into flight testing. In a previous paper,⁶ we described using M&S to extrapolate test data both horizontally (at the same level of MOE), and vertically (to higher level MOEs) after flight testing was completed. This is often required to expand the range of the results – e.g., to threats or scenarios that could not be tested – or to address performance at a level that could not be tested – e.g., at a campaign level.

Modeling and simulation can also improve OT&E by being used in pre-test activities, including the following:

- **Rehearsal:** Flight testing is expensive. By rehearsing the test in a simulator, the chance that a test will be ruined or compromised because an operator did not fulfill his role in the scenario can be reduced.
- **Scenario selection:** Usually there are more scenarios of interest than can be actually flight tested. By analyzing the scenarios with M&S, the best scenarios can be selected for flight testing. These scenarios can be chosen by selecting the most stressing cases, or they can be chosen by selecting the operationally representative cases, or by other criteria.
- **Training:** Like rehearsal, expensive flight time can be reduced by training operators in simulators before flight testing. Consistent levels of maturity – useful for ensuring comparability of test results – between

⁶ "Modeling and Simulation in Operational Test," David Wiesenhahn and Robert Dighton, presented at the 1995 Military, Government and Aerospace Simulation MultiConference, April 1995.

operators can also be achieved via a simulation-based training program.

- **Tactics development:** Tactics usually take a while to develop for new systems, yet tactics can influence the effectiveness of the system. Pre-test simulation can be used to develop and refine tactics that make optimum use of the new system's capabilities before testing.

THE CHALLENGES FOR MODELING AND SIMULATION

Accuracy

The previous section described various ways in which M&S could be used in an aircraft OT&E program. It was suggested that there is potential for integrating M&S into the flight-testing environment, and possible pre- and post-test uses for M&S were also discussed.

Throughout the test-planning process, the goal of achieving an accurate evaluation must always be kept foremost in mind, especially when incorporating M&S into the test program is considered. It makes no sense to attempt to correct a shortcoming in the test program with M&S if the M&S actually degrades the accuracy of the result.

In listing the uses for M&S above, a distinction can be made between those that directly influence the accuracy of the results and those that have less influence; accordingly, the accuracy demands for M&S used in the latter group will be less. M&S used in pre-test activities will generally have less influence on the accuracy of the evaluation. For example, if the flight-test scenarios were chosen based on an M&S analysis and these turned out not to be the best choices of scenario (by whatever criteria were used), the evaluation results can still be accurate, even if they do not necessarily apply to the optimum scenarios.

On the other hand, M&S used directly in flight testing and for post-test analysis and extrapolation will usually have a direct influence on accuracy. To take a simple example discussed above, it is impossible actually to launch missiles at piloted aircraft. This can be corrected by using a model to simulate the missile launch, guidance, and fuzing. However, if for whatever reason the simulation is not sufficiently accurate or, in the worst case, contains a bias toward one system, misleading results could occur. In this case, it may be better to back up a step, and examine, for example, the possibility of using shot opportunities (i.e. before missile launch) as an MOE. Indeed, as discussed above, the inaccuracy induced by this simulation could dominate smaller inaccuracies throughout

the remainder of the test, which may have been achieved only through costly and painstaking effort. Thus, in this example, even though a deficiency in the test program had supposedly been corrected by M&S, it is possible to wind up with a less desirable evaluation.

Even though accuracy is important to all users (not just test and evaluation users), few models and almost no simulations report what kind of accuracy can be expected when using these tools. Sometime models and simulations are given caveats that they should be used only qualitatively, e.g., to determine trends or to rank alternatives. Part of most verification, validation, and accreditation (VV&A) processes is a determination of the limits on where the model can be used and remain accredited; this is presumably based on some predefined accuracy, but for the most part, the VV&A process does not explicitly yield an estimate of accuracy.

Although the definition of the accuracy of a model or simulation is conceptually easy to understand it can still be difficult to quantify accuracy for a simulation that models something as complex as a military battle. Clearly, accuracy should be based on how well the output from the model or simulation agrees with reality, but at what level should this comparison be made? Consider the missile fly-out model discussed above. A comparison could be made based on the overall probability of kill (Pk) given any shot within the weapon-engagement zone. It could also be based on Pk segregated by launch conditions. The comparison could also be made at a lower level, such as miss distance or fuzing distance and geometry. At an even lower level, the signals generated and received by the actual seeker could be compared to those in the model, as could the fin deflection and guidance commands.⁷

All models and simulations – even physics-based models – will have some compromises and limitations known to the developers. If the accuracy of the model or simulation cannot be quantified in a rigorous manner, the limitations should at least be disclosed as part of the program's documentation so that the user can determine if it meets his needs. Convincing the developers actually to do this may be difficult, because they might feel that a limitation in their model could be perceived as a deficiency.

⁷ This approach is used by the Joint Accreditation Support Activity (see <http://www.nawcwpns.navy.mil/~jasa/>).

At the beginning of this paper, we stated that different users will generally have different modeling and simulation requirements. Likewise, different users will have different ways to describe the quality of a model or simulation. A common term used to describe this quality is "fidelity." Unfortunately, there is no standard definition of fidelity, and this term may mean different things to different users. Other terms, such as "credibility," "resolution," and "precision" are related to fidelity and are often used to describe M&S quality, but these terms also lack an accepted set of rigorous definitions.

One use of "fidelity" is based on the resolution of displays, input data, or time step used in the simulation. In this case, the higher the resolution, the higher the fidelity. To some user communities, such as training, this definition is important and a valid measure of simulation quality.

Another common usage of "fidelity" is that it describes the agreement between the model or simulation and the physical world. This can be based on comparing the number of entities in the simulation to those in the battle being simulated, and leads to the common notion that the bigger the simulation is, the better it is. However, if the comparison between reality and simulation is based on the *output* of the simulation, then "fidelity" corresponds to "accuracy" as we have been using it in this paper. *Note that simply increasing the resolution or the number of entities in the simulation does not necessarily guarantee increased accuracy.*

Care must be taken when discussing the quality or fidelity of a model or simulation to ensure that the definition is understood by the user and it is appropriate for the user's application.

Simulating Complex Warfare

Given the emphasis on accuracy throughout this paper, it is a fair question to ask: are we capable of accurately simulating large-scale warfare on digital computers? Even if we had infinite computational resources, can we write algorithms for all the physical processes relevant to the battle, and can we populate those algorithms with sufficiently accurate input data? Can we characterize the human element – so important in all warfare – in terms that a computer can process? Can we even identify all of the factors *a priori* that influence the outcome of a battle?

Military warfare includes a tremendous range of physical phenomena, and, to model these, we must be able to describe each phenomenon analytically in mathematical terms. For example,

air combat involves propulsion (from jet engines and missile motors); aerodynamics (for both aircraft and missiles); electromagnetic emission, propagation, and interaction (radar and infrared sensors); signal processing (radars, sensors, and avionics); and ballistics (warhead detonation and effects). Environmental phenomena, such as weather and background clutter, must also be considered. Fully describing each of these phenomena with computer algorithms that minimize error are full-fledged research areas in their own right, and bringing all of these together in a military simulation may be an impossible goal.

Besides modeling the physical processes themselves, the interaction between these processes must also be modeled. Sensors interact with man-made systems (both friendly and enemy) and with the environment. Human operators interact with displays and flight controls. Missiles receive cues from the host system before launch, then interact aerodynamically with the atmosphere. During guidance, the missile may continue to interact with the host system or it will interact with the target aircraft, which may be maneuvering or changing its signature. If the missile fuzes and detonates, the warhead fragments will interact with the targeted aircraft.

Even if algorithms are developed for all the physical processes and their interactions, some amount of input data will be required. Ensuring the quality of these input data is important, since the overall accuracy of the model is directly correlated to the accuracy of the input data. These input data could be fundamental physical-property data – for example the temperature distribution and emissivity of the airplane skin, required to calculate its infrared (IR) signature. These input data could also be measurements made in developmental test, such as the radar cross-section (RCS) of an aircraft. Again, considering the breadth of a force-on-force military simulation, these data requirements may be significant. For example, in order to accurately calculate the IR signature, the emissivity of the aircraft skin in the above example should be known as a function of angle, wavelength, and temperature, and the temperature would need to be known as a function of the flight envelope. In the other example, the RCS may need to be known as a function of frequency, and at closely spaced values of azimuth, and elevation. This volume of data may be onerous for friendly systems, and completely impractical to obtain for enemy systems.

Authoritatively modeling human behavior is difficult, yet it is an important factor in combat. The outcome of a battle can be decisively influenced by strategic decision-making, tactical action and reaction, human blunder, or uncommon valor. Some air-combat models have attempted to model the human decision-making process. However, VV&A of the human part of these models has not been done rigorously, and, indeed, a rigorous method of validating human behavior may not be possible. One option is to obviate the need for digital human models by using man-in-the-loop simulators. Of course, special effort may be required to train some participants to act like foreign operators.

Another challenge facing simulator developers is to model "unknown-unknowns." A simulation or model can only do what it's been programmed to do, yet in every test, and in warfare itself, things that were completely unanticipated will occur. Despite the system designer's best efforts to anticipate every use, misuse, and problem that could occur with his system, these unanticipated unknown-unknowns may be serious deficiencies with the system, and uncovering these problems may be an extremely important test result.

Cost

Simulations are often touted as being far cheaper than field exercises. This claim is usually made on the basis of the cost to run one engagement of a computer simulation compared to the cost of performing one similar exercise in the field with real troops and hardware. On this basis, the field test might cost tens or hundreds of thousands of dollars, or even millions of dollars, whereas an execution of the simulation might be many orders of magnitudes less.

Considering the deployment and sustenance of personnel and equipment sufficient to replicate an engagement, it is true that field testing can be quite expensive, but it has not yet been demonstrated that simulation offers all of the cost savings anticipated. One problem with comparing the cost of simulation to field testing is that when the cost of simulation is reported, it is usually the cost required to run one scenario, and does not include the capital cost required to develop the simulation, nor does it include the cost to maintain the code. VV&A costs can be an alarmingly high part (at least to the simulation developer) of the total simulation development cost, but are also usually not included in the price quoted to run the model.

Tied in with this discussion is the notion that since simulations are cheap to run, they can be executed multiple times to gather "data," improving the statistical confidence in the results and precluding the need to conduct multiple trials in the field. For this to be true, the variations in the fundamental processes that cause variability in the actual tests must be characterized and replicated in the simulation. However, if we can conduct enough tests to characterize these processes, it may be argued that we have conducted enough tests to characterize the *system*, and that additional simulation runs will not provide any useful information. Thus, this is a circular argument. There is an exception to this, which presents a good opportunity for M&S. If components of the actual system (including the human component) are embedded into the simulation, *a priori* knowledge of their statistical behavior will not be required.

Few studies have been done to determine the cost savings obtained by using M&S in test and evaluation in particular and acquisition in general.⁸ There is no doubt that engineers will use M&S when it intuitively makes sense, and there is no doubt that M&S has improved product quality, decreased development time, and lowered the cost in both the commercial and military sectors. However to truly quantify the value that M&S adds to military acquisition, rigorous and objective studies must be performed, preferably based on a comparative analysis; however, given the uniqueness of large military acquisition programs, this will be difficult.

CONCLUSIONS

Operational test and evaluation is a valuable part of military acquisition. Mostly because of the nature of flight testing, OT&E of aircraft has several important limitations, but modeling and simulation holds promise to overcome these limitations and improve the quality of the operational evaluation. However, the needs of the test and evaluation user of modeling and simulation may be different from the more familiar needs of the other communities, such as training. Along with these needs comes a set of challenges that the M&S community must understand and overcome.

8 One such report is the "Study on the Effectiveness of Modeling and Simulation in the Weapon System Acquisition Process," written for Deputy Director, Test Facilities and Resources by A. Patenaude, D. Helmuth, P. Potter, and M. Borowski, October 1996 (<<http://www.acq.osd.mil/te/pubdocs/acqstudy.htm>>).

**The Role of Test and Evaluation in Early 21st Century
Systems Engineering**

Prof P H Sydenham, Defence Engineering Group Systems
Engineering Team, University College London, UK and
Australian Centre for Test and Evaluation, Australia and
Mr D Kimberley, Defence Engineering Group Systems
Engineering Team, University College London, UK

THE ROLE OF TEST AND EVALUATION IN EARLY 21ST CENTURY SYSTEMS ENGINEERING

Peter H Sydenham

Defence Engineering Group Systems Engineering Team
University College London, UK

and

Australian Centre for Test and Evaluation
Adelaide, South Australia

David Kimberley

Defence Engineering Group Systems Engineering Team
University College London, UK

Abstract

Test and Evaluation is no longer a stand alone activity but is considered to be a fundamental and integral part of the Systems Engineering process i.e. the overall system design and manufacture. By considering how change comes about and listing aspects of change in Systems Engineering at large, future Test and Evaluation practice has been investigated. It is shown that there are many factors to explore and that they are highly interactive. It is clear that there will be major changes and that no simple action can be taken to keep abreast of change. Improved training and qualification for T&E practitioners offers the best protection against an uncertain future.

Specific findings are:-

- T&E practitioners will be integrated into Systems Engineering teams.
- Education and Training for future T&E need to be reviewed and revised.
- Virtual systems will become the normal test environment.
- The major T&E challenge will be to validate the virtual environments.
- Test ranges and test equipment will still be needed but will be used sparingly.
- Test and Evaluation will become accepted as the key validation hub providing feedback at all stages of a project.
- Test and Evaluation will be in use to test all manner of variables, including the subjective soft systems parameters.
- Test engineers will need to be familiar with the phenomenological approach of Soft Systems as well as with the reductionist approach of the scientific and engineering disciplines.

Overall, enterprises need to examine their attitude to T&E and put in place means to keep up with the Best Practice and be able to contribute toward Future Best Practice.

What will Systems Engineering practice entail in the early 21st Century?

The Cost, Time, Performance Factors

Test and Evaluation (T&E) is no longer 'test as you go'. It is fast becoming a key part of the overall process of how systems evolve (Systems Engineering). To see what T&E changes can be expected to arise it is first necessary to consider the likely changes in Systems Engineering.

The main interacting drivers of Systems Engineering, due to market pressures, are: -

- Cost
- Time to market
- Performance / Contractual compliance.

These Cost, Time, Performance (CTP) goals have always been important but today they are crucial to economic survival. Improvements have been achieved, not so much by tuning at the edges, but by applying innovative and unexpected thinking on how to optimise all of these factors at once.

Some Ideals of System Engineering Methodology

The perfect design situation would allow the requirement to be met with zero design and implementation risks. To do this it strives, but never reaches, the goals of having perfect: -

- Assumptions
- Requirement extraction
- Specification development
- Design process
- Test and evaluation
- Technology
- Human interactions.

Factors of change

Processes by which the need is met can be characterised as: -

- Extrapolation of current ways, including cross fertilisation
- Implementation of plausible, science fiction-like, ideas
- Unexpected mutations of the process, or technology employed.

Changes in human attitude due to cultural workplace changes, politics, industrial trends, social forces or war are also vital factors.

Extrapolation of current ways

Examples of these are easily seen once sufficient awareness of the situation is obtained. A problem for the observer is that some major changes are assuredly being carried out in relative secrecy inside Corporations and defence circles. One cannot be fully certain of where the industry is on the curve of improvement. Once the change factor had a time constant of some 10-15 years for

major systems. Recent developments have shortened this to 3-4 years and in some cases to 1 year or less. Even less is the target today.

Obvious factors causing change are: -

- Improved Systems Engineering processes involving increasingly more digitisation
 - Progress against the requirements for “Cost, Time and Performance”.
 - Ownership of the process: suppliers will control the after sales situation as their investment in models and staff formation is not passed on to the buyer.
 - Computing techniques will improve interactions but will complicate the T&E validation process. .
- Integrated Processes and Recurrent Engineering
 - Experiences have now proven the worth of integrated processes in improving all of the CTP factors. Enterprises, at all levels of scale, are adopting this more common-sense approach.
- Virtual operation of development
 - Already in use, but being slowed by lack of proven techniques for running computer systems in a virtual network at the designer’s knowledge level.
 - Global distances not a factor. Examples are India used to service software and printing; Motorola making use of Internet to control CTP factors of work taking place across the globe.
 - Travel to be physically close will lessen as virtual reality allows equivalent experiences
 - Virtual experience becomes the norm.
- Reuse allows evolution based on previous generation
 - Well understood in Japanese consumer electronics and car industry. Now being adopted in defence sector via COTS and evolving designs.
- Systems of Systems - emergent properties the issue
 - Many systems are now mature with little real change in how they are used and interact with other systems - cars, telecommunication add-ons, white goods, computing such as personal computers.
- Front End Loading (FEL) becoming the focal area for effort
 - CTP forces demand less risk in design
 - Much more efficient to spend more effort at FEL stage than correct errors later
 - Engineers will need to be more familiar with FEL work and problem solving; they will be less involved in the detailed design that they are taught today
 - There is an Academic Engineering support lag of around 10 years here. Research programmes and syllabuses are trapped in outmoded paradigms.
- Minimal time to market concepts are in vogue
 - Boeing’s 6 month plane concept
 - 2 day house
- Demand for this mode of thinking is high as reduced time to market cuts costs of design, puts the system into service faster and avoids customer requirement changes and being second in the market place. Safety and other performance issues are in danger of neglect. This places far higher demands on error free FEL work.
- Greater automation of latter stage design
 - Much of today’s sub-systems developments are done using design tools that are increasingly becoming automated and that interface digitally to the digital factory.
- Reduced manufacture of prototypes
 - Designs held in digital form until the final physical system is needed.
 - Less need to build test objects to see if they are acceptable and ready for a new market or military requirement.
- Smarter, more aggressive, customers
 - Highest ever expectations
 - Competition and ‘bottom line’ costing attitudes give the customer a better edge over the client.
- Ever increasing computer power
 - Knowledge processing now faster and better, no limit to be seen ahead
 - Greater detail in simulations
 - Easier to use and train to use.
- Adoption of knowledge based thinking in systems design - as opposed to data processing thinking
 - Knowledge based systems were slow to emerge as they confront the reductionist thinking of engineers and hard scientists.
- Increase in legal requirements
 - Hundreds of Environmental, Occupational Health and Safety, Trade and Industry and other laws increasingly impact on systems development and operation. Physical testing getting harder and more expensive to carry out.
- The, adversarial, litigious society demands higher degree of expectation of supply
 - Law suits have become the answer for disappointment
 - Legal liability is a minefield. T&E process can assist in limiting claims
 - Settlements can bankrupt a Systems House
 - Increasingly harder to predict the outcome of legal suits.
- Change and re-engineering of work forces
 - Accepted as normal
 - Constant state of apparent improvement currently ignores human factor.
- Union forces not holding length of tenure
 - Vendor able to be take more risks as workforce costs are more flexible
 - Short contracts give workers less security

- Vendor system's development and continuity history is weakened, especially in software areas.
- Simulated Test and Evaluation Process of US DoD
 - Processes in defence must be open thus being at odds with CPT factors
 - STEP is latest showing of major shifts in process.

It is to be noted, however, that many of the issues listed above cannot be met by the discipline of engineering as it is constituted today. Many other disciplines are involved. Systems Engineers need to be broader in horizon. Multidisciplinary teams (that is, those containing contributions from the Arts, Sciences and Engineering - not just a mix of different branches of engineering) are essential. They require visionary leaders who are supported by people able to synthesise and analyse the innovative measures suggested by the leaders.

Systems Engineering will continue to evolve and keep seeking improvement as the many forces at play flex with time.

Implementation of plausible science fiction-like ideas

These cannot be forecast with anywhere the level of certainty of the extrapolated parameters. Although these are easy to suggest it has been, to date, only the science fiction authors and cartoonists that have been able to mould these into virtual scenarios. Virtual reality computer based methods now allow such fantasies to be exercised to see how they might work in dynamic situations.

A few of the obvious developments that can be foreshadowed as plausible, but for which it is very uncertain as to when they will come into practice, are now listed. They may appear to be somewhat far off of the topic of 21st Century Systems Engineering practice but their description paints the kind of scenarios that could arise illustrating that the situation could be quite different to the extrapolated future described above. The future will certainly reveal some most unexpected changes. An eminent physicist in 1950 suggested that the transistor might find limited use to make smaller walkie-talkie radios but apart from that it was hard to see where it would have much impact!

Examples of the plausible great changes are:-

- Chemical signal processing replaces the current non-living physical method massively reshaping the IC, electronic systems and computing industry. Features of these information processing systems would be:-
 - Self repairing
 - Self evolving
 - Self reproducing
 - Require radically different means of design, use and manufacture
 - CTP drivers again improved

- Gene engineering
 - Improved performance of living things
 - Different human class
 - Potential deleterious effect on humans
- Anti-gravity suspension using low energy
 - Drastic changes to transport systems and equipment
- Practical use of yet undetected minor physical forces
 - Gravity waves give new communications medium
 - ESP and the like with humans able to read minds
- Human thinking
 - Changed directions for scarce resources uses
 - Major wars with physical or trade weapons
 - A less selfish, more caring, society might emerge.

Unexpected mutations of the process or technology.

True mutations of note cannot really be forecast leaving us with unscheduled changes that can have potentially great impact - for both the good and the bad. These can be totally unpredictable despite the best use of expert's ideas through Delphi forecasting techniques. Mutations have to be allowed for as they occur. Fortunately, they usually give us some notice of the change and gradually move from the fantastic class into the extrapolated kind of change.

Current State of T&E Practice

Test and Evaluation is carried out somewhere between two extremes of philosophy.

In the 'experiential' approach a 'build and test' sequence is followed to see if the sub-systems built do perform to test requirements that tend to be decided upon by historical practice and local appreciation of the system need. Here the practitioner's confidence stems from their professional experience but there has been no way of satisfactorily proving that it is right. This approach sufficed when the lead times were long and the TCP parameters were not under the extreme pressure experienced today. Shorter time-scales, better documentation and widely distributing the process detail makes it harder to hide errors or lay blame elsewhere.

In the 'Master Planned' approach, T&E is made a focal part of every stage of the whole process from conception to taking the system out of service. Tests collect key information that enables evaluation of performance according to an overall plan set up from the commencement of the project. The tests, and the use of test data in evaluations, are set up to map upward to the give indicators of success at meeting the requirement at the operational level.

Another limiting factor about current T&E is that there is still little requirement for formally certificated T&E

qualifications in which practitioners are assessed as to their experience, educational and skill levels.

T&E make use of very expensive test facilities in which many tests are carried out. Tests are often used to get stages signed off rather than using to inject wisdom into the FEL stages. As recognised above, this is will increasingly change.

T&E in the Early 21st Century

Obviously T&E is a major discipline with increasing importance in controlling CTP risk factors. As Systems Engineering Best Practice changes then so will the need for T&E practice to change and to contribute to key project decisions. It can be argued that T&E will be a more important activity than it has been seen to be to date. It seems to be a truism that the T&E personnel are able to assist ensure the system design is 'right' more than any other discipline involved.

It is not possible here to comment on all issues raised earlier in this paper. Scanning the list of changes in Systems Engineering methodology shows that certain issues are dominant.

Overall one thing becomes clear - the various change parameters are inter-related to a large extent showing that the best practice will be constantly changing with time constants of utility reducing to a matter of a year, or less, for a given set of practices. Practices could therefore need to change within the life of project or be capable of being completed ever more quickly!

A few factors of change are now considered giving brief outlines of how T&E will change because of them.

Digitisation and Virtual operation

Placing the systems design into a computer-based simulation has required dramatic change in the attitude to design and evaluation. A decade ago the then available level of Modelling & Simulation (M&S) was not really suited to the high level system decisions that had to be taken. M&S now supports scenario building, prototyping, subsystems design, manufacturing try-outs, machine tool and production line set up and control of manufacturing. It also supports servicing, configuration management, training and more. It will be able to do even more in the future and will form a key element of any contracted procurement.

The demands for test ranges and equipment has changed significantly due to adoption of digitisation. The changes emerging are:-

- Full scale, long period physical testing will be less practical
- Live fire and other 'final' testing will become environmentally unacceptable

- More special, rapidly configured, test set ups are needed
- Test personnel will need enhanced problem solving and digital skills and will be an integral part of the Systems Engineering team.
- Test personnel need improved training and recognition if they are to be accepted within the teams
- Computer environments will require validation at all stages of development requiring new forms of test bed used in the distributed interactive mode
- Nodes of the system design process must communicate unambiguous design knowledge, not just data sets.

Integrated Programmes and Concurrent Engineering Methods

Bringing more functions together earlier has the potential to uncover design flaws where they are far less costly to fix. This paradigm has become known as the Integrated Product and Process Development (IPPD) method. When a representative group of experts are assembled as a team they are able to develop better appreciation of the interactions within the design situation. They must be careful to ensure that their decisions are sound and that risks are understood and minimised. The concept has been proven. The pivotal role of T&E is clearer in this methodology; it is used as a source of wisdom, not just as an 'after the fact' test to prove things are in order.

Some eight years after the integrated development approach was first implemented, the US Department of Defence has gathered the best of the IPPD process into the Simulated Test and Evaluation Process (STEP). This has compacted the expected milestones time span and, most importantly, placed evaluation at the hub of each stage of the process. They have made it clear that T&E is a central feature of all stages.

This methodology brings with it greater need for means to better evaluate subjective decisions, soft systems, requirements and specifications as well as the performance of conventionally engineered artefacts. It also calls for ways to evaluate models at their various stages of development.

As much of the system is in a digital simulation form the testing is now different. Physical test equipment will still be needed but now they are not facilities that are used for prolonged periods but need to be able to be set up rapidly, under computer control, to carry out specific routines needed to verify point profiles in the performance of the digital model.

At present there is low confidence in the model as the final representation. It is clear, however, that models are fast becoming reliable equivalents of the real thing - as long as they are calibrated appropriately and used intelligently.

Education and Training

Assuming that most of the development process will reside in the digital domain then T&E personnel will need to train appropriately. Looking forward a decade we can expect they will need to be capable in virtual modelling, in the testing of models and when and how to use physical test facilities to improve the model.

It is clear that education and training is a vital underpinning activity for all of the change parameters.

Facilities

Legal and economic forces will work to make it harder to keep large facilities in a state of the readiness needed. There will be need to condense range assets and investment which will be in conflict with the need to have access to test facilities with adequate accuracy to ensure the points in the model have low enough uncertainty, and good automation and digital interfaces. Study is needed to see how the many conflicting factors can be harmonised to ensure the models can be kept well calibrated.

Systems of Systems

It is now clear that the larger systems should be viewed as Systems of Systems (SoS) in which each system interacts via its own emergent properties. Thus System design has to cope with more system level blocks but with reducing interest in their internal behaviour.

This change in perspective to 'whole of enterprise' modelling requires that the individual models interface efficiently. Testing interfaces and SoS models requires a quite different kind of capability to that of the software and equipment tester of today.

Minimal Time Concepts and Emphasis on FEL

Increasing the effort in the FEL area needs high budget loading at the early stages. Governments seem to find this hard to set up for it runs counter to many of their budgeting processes. Indeed maintaining team knowledge when projects are brought to fruition sooner and replacements sought less frequently, will require improved knowledge capture and transfer. The commercial world already faces this dilemma but has to do it to compete. Government procurement must change to provide high FEL as this is a major key to meeting CPL factors.

Again we see that Test and Evaluation personnel need to be trained to be able to contribute well in FEL work. This requires quite different training to that given today.

Knowledge Capture

Reduced programme time-scales, fewer less frequent projects, increased use of existing items and data, all point to the need to develop enhanced knowledge capture and

transfer. For T&E this will increasingly mean that revised analysis of previous testing will become politically necessary and more cost effective than new tests. Environmental issues will cause all new real testing to have to be justified. Increasingly sub-contractors that can supply "certified" products in short time scales will have a major competitive edge. This will put further requirements on parts of the T&E community who will need to understand the reworked testing and/or keep records of their own.

Humans in the process

The final aspect to be covered here is that the thinking processes of the human mind are becoming identified more with the new processes. It is becoming clear that the ability to synthesise new ways in a supportive environment is needed. Humans in Systems Engineering cannot be treated as deterministic processors. Placing them into rigid processes where Capability Maturity Models and Quality processes are expected to yield optimum overall team performance has now been seen to have its shortcomings. Soft Systems thinking is needed and this uses different means of inquiry to engineering and science. Test and Evaluation personnel are rarely equipped to evaluate this aspect of systems.

Conclusion

Test and Evaluation is no longer a stand alone process but is considered to be a fundamental and integral part of the overall system design and manufacture Systems Engineering activity. By considering how change comes about and listing aspects of change in Systems Engineering at large, future Test and Evaluation practice has been investigated. It is shown that there are many factors to explore and that they are highly interactive. It is clear that there will be major changes and that no simple action can be taken to keep abreast of change. Improved training and qualification for T&E practitioners offers the best protection against an uncertain future.

Specific findings are: -

- T&E practitioners will be integrated into Systems Engineering teams.
- Education and Training for future T&E need to be reviewed and revised.
- Virtual systems will become the normal test environment
- The major T&E challenge will be to validate the virtual environments.
- Test ranges and test equipment will still be needed but will be used sparingly.
- Test and Evaluation will become accepted as the key validation hub providing feedback at all stages of a project.
- Test and Evaluation will be in use to test all manner of variables, including the subjective soft systems parameters.

- Test engineers will need to be familiar with the phenomenological approach of Soft Systems as well as the reductionist approach of the scientific and engineering disciplines.

Overall, enterprises need to examine their attitude to T&E and put in place means to keep up with the Best Practice and be able to contribute toward Future Best Practice.

Acknowledgements

Keeping abreast of changes in T&E is considerably helped by the effective operation of the global network of practitioners forming the International Test and Evaluation Association (ITEA). The Authors wish to recognise the membership of ITEA at large for their rapid and always helpful assistance.

Generous co-operation of the staff of the Defence Engineering Group, UCL is also acknowledged.

The many people who attend short courses given by the Defence Engineering Group Systems Engineering Team (DEG-SET) and the Australian Centre for Test and Evaluation (ACTE) also provide the authors with valuable insight into the Best Practice of Systems Engineering and its Test and Evaluation.

Peter Sydenham is the recipient of several Australian Government and industry grants from British Aerospace (Australia), and the Defence Teaming Centre, Adelaide

**A Future Instrumentation Concept, Suitable for
Test and Training**
Mr M L Burski, Institute for Defense Analyses, USA

A FUTURE INSTRUMENTATION CONCEPT, SUITABLE FOR TEST AND TRAINING

Michael L. Burski
Institute for Defense Analyses
Alexandria, Virginia USA

Abstract

A desire for future instrumentation is the ability to provide data for both test and training users during a single event. Conventional wisdom assumes that there are significant advantages to performing both together. Efficiencies of resource use (time, people, money and equipment) are the expected advantages. The design of a single tool (read: instrumentation system) seems feasible. This paper proposes a conceptual tool that is basic enough to be valuable to both communities without being expensive, complex, biased or restrictive.

A need common to both users is position of participants. The instrumentation design is then determined by answers to the following questions. How many participants need to be monitored? What are the types of participants? Where is the event performed (size, location and environment of the sandbox)? What accuracy is needed? When and where is the data needed (feedback, display, archiving)? What will the tool cost? When can I use it? What are its care and feeding requirements?

Past and existing systems had specific needs based on performing a specific task. Testers and trainers are different from each other. Their needs, events and methods are different. I am proposing a time, space, position information (TSPI) system concept that will be sufficient for both groups in the majority of their endeavors.

The proposed system will use two technologies to achieve its objective: providing suitable and efficient TSPI for both types of users during a single event. The two technologies are the Global Positioning System (GPS) and a low-earth-orbit satellite system. The first is capable of determining suitable and efficient TSPI. The second is potentially capable of communicating that data, suitably and efficiently, to its appropriate destination.

Introduction

This document describes an instrumentation concept, suitable for both test and training events.

That simple sentence conjures many different and unique visions. A clarification of the terms is thus necessary as a precursor to the description of the instrumentation concept. This concept is, as Webster defines it, a general idea or understanding derived from specific events.

Test

A test event seeks knowledge. Cause and effect are determined by adjusting variables, obtaining appropriate data with a set of instrumentation and analyzing that data. The test methodology must be appropriate for the objective sought. Tests normally occur in a sandbox. My vision of a sandbox is an environment conducive to achieving the objective information. It may be an open-air range having all necessary manpower, equipment, instrumentation, data reduction, needed feedback loops and displays. It may also be a single tool that stimulates an electronic circuit and records the response. A computer, running models having well understood, well documented and valid algorithms can also be a sandbox. There are many more sandboxes. The objective of a test is confirmation of hypotheses. How does something work? How well does it work? What are the conditions when it works less well or not at all? What can degrade performance or stop it from working? What care and feeding procedures are appropriate and how do they effect performance?

Training

A training event teaches lessons that are based on the knowledge gained through testing. It spans the instructional gamut from individual learning to large-group learning, and includes many desired outcomes. It also occurs in sandboxes, although the characteristics of a training sandbox may differ from characteristics of a test sandbox. Feedback is often

vital, suggesting realistic latency needs. The information from a training event (obtained from instrumentation) must reinforce good behavior and punish bad behavior.

These are simple descriptions. Both types of events need to be well understood and well documented if they hope to achieve their respective objectives. They differ in scope, resources, management, control, structure and responsibility.

Instrumentation Systems

Instrumentation is the defining factor of test because it alone produces information. Objectives are obtained only by analyzing that information. Training is possible without instrumentation, but the absence of data makes achievement and measurement difficult.

The first question in either endeavor should be "What do I want to learn or teach?" The answer to that question defines the quality and quantity of information that is necessary. Instrumentation determines the data extracted from the test or training implementation.

Has instrumentation changed over the past 25 years of my experience in testing and a lifetime of learning? My answer is an admittedly ambiguous "yes and no". Changes are continuously being proposed and implemented in the quest for improved performance. Technological advance may improve our ability to obtain information that was previously unobtainable. The constants are less noteworthy but no less important. We still use many procedures and systems that have existed for decades or generations. Many concepts seem ageless. "Faster, better and cheaper" are the rewards for appropriate change but the principles remain fixed.

Combining test and training

The current test and training quest seems to be a desire to combine the two events. I was asked to prepare this paper based on the stipulation that obtaining test data in a training event, or training data in a test event, was desirable. My experience does not allow that stipulation. I have accomplished and witnessed tests with dual users. Some work well and others don't. Training of some type results whenever a task is performed, but the lessons learned

may be good, bad or indifferent. I have never seen a precise determination of cause and effect during a training event because control of variables is normally insufficient. A case by case analysis of the goals and procedures of any one event may yield specific instances where data are appropriate for both testers and trainers, but universal benefits to both groups from a single event have not been documented. Bias is very likely to exist in data that results from any event. Understanding the nature of that bias (time, participant qualities, environment, methodology, event control, procedures, and incentives, to name a few) is important. Bias can be overcome only if the event is well understood, well managed and well documented, which may be costlier or less effective than two separate events.

Combination of test and training is not a panacea to reduced cost/time/people/equipment (read: resources). The desire to accomplish more with less is commendable and the propensity to state "here is the answer" is understandable. Limitations, risks and consequences of combination must be thoroughly considered and documented. I would be glad to receive and debate the thoughts of any reader on the pros and cons of such a combination. (burski@mindspring.com) I make that offer confident that the concerned audience for this subject is small.

Is there an instrumentation concept that might allow generation of suitable data for different users during a single event? I believe the answer to that question is "yes" with the following limitations.

Concept Scope

I will limit the scope of this report to test or training events that occur with actual participants. These events might take place on any suitable real estate, worldwide, including ships and simulators. The participants may be a few soldiers or vehicles from a single military Service, or they may be a thousand-plus entities opposed in joint exercises.

The proposed instrumentation system will be described in general terms only. My experience in responding to request-for-proposals is that strict, detailed, directive criteria are not conducive to success because innovation by experts and "out-of-the-box" novices is precluded. People are ingenious and inventive when they are allowed latitude in

problem solving. Guidelines are appropriate to avoid historical problems but they can quickly become inflexible and stifling.

Concept Requirement

Data Suitable for Two Users

What data is necessary for both testers and trainers? Time and position of participants meet that criteria. It is not a new or original idea to restrict an instrumentation system to time, space, position information (TSPI) but my primary objectives in providing data to two users are simplicity, validity and universality.

Why is all data but TSPI precluded? An example of information normally desired, but not included in this instrumentation concept, is scoring of weapons. Scoring is now accomplished in many different ways by many different instrumentation systems. Scoring requires a considerable amount of weapon setting, aiming, trajectory, countermeasure and firing information, violating my goal for simplicity. Pairing is reasonably valid scoring for only a few weapon/target combinations. Scoring is available today (with a few exceptions) only on instrumented ranges and not in diverse locations, including urban environments, that exist off-range.

A single quality and quantity of score information is not likely to satisfy the requirements of two different users. Scoring that is sufficient for training may not accomplish a test objective, and *vice versa*. A middle-ground compromise may result in conclusions that are incorrect or misleading for both groups.

I oppose adding scoring to this instrumentation concept because high quality scoring data is difficult to achieve. It is expensive, complicated, restrictive to normal task performance, bandwidth hungry, bunched in time, feedback inducing and quite nasty to validate. If scoring data is not of the highest quality, it is incapable of supporting several users because the data will likely be insufficient for many needs. That does not seem cost effective. Limitations of the instrumentation will be quickly forgotten (if ever learned) and it will be used for inappropriate objectives, i.e., it will provide biased or incorrect data.

The same rationale is true for all information except TSPI. TSPI is the only data that may satisfy many users from a single event, with one set of characteristics.

The instrumentation system should also have the following additional characteristics: accuracy; reliability; value and low-cost. I will briefly discuss my understanding of each of these characteristics.

Instrumentation Characteristics

Simplicity An instrumentation system is simple if it consists largely of existing technology. I don't want it to be ten years in development and difficult to achieve. I also don't want it to be cumbersome to a participant. The participant must perform his or her tasks in a manner that is identical to performance without the instrumentation system. Simplicity also implies reliability, which means ease of installation, initialization, diagnosis and repair. It must have a high utilization rate. Any system that loses half its data or is inoperative half the time is quite worthless because the important data may be that which is missing.

Validity The data must be based on truth. For this instrumentation concept, data is time and position. How is time data achieved? How is position data achieved? What are all sources and all algorithms used in data accumulation, from the first sensor reading, through transmission, to ultimate display, integration or archiving? What manipulations, translations, shortcuts and assumptions are made in the accumulation of information?

Universality The instrumentation must be usable by all appropriate participants, in any location on the surface of the earth. An aircraft might not be an appropriate participant because aircraft certification is complex and aircraft operating conditions are extreme. Existing aircraft instrumentation may be able to provide suitable time and position data for integration with data obtained using this proposed concept. "Any location" means that natural or manmade obstructions and interference should not preclude the instrumentation system from achieving its goal, the collection of information. In fact, the latter criteria is unlikely to be absolutely achieved, no matter what the cost. A reasonable compromise between performance and cost may be that some definable obstruction or interference is acceptable.

Accuracy The instrumentation system must produce data accurate to some definable measurement, for some definable percentage of its operating time, with some definable level of confidence. I would allow the manufacturers to set accuracy parameters they believe are achievable and then enforce strict warranty procedures. As an approximation, I would expect X, Y and Z positions to be within three meters, time to be within one tenth of a second, operating percentages in the mid nineties and a confidence of 95%.

Reliability This characteristic is common to all military equipment used in the field. It must be robust. It should work when it is turned on and perform in a harsh and unpampered environment. It should be easy to determine suitable operation. Troubleshooting and repair should be relatively quick and simple.

Value The potential benefit to be gained by any system is much more difficult to define and measure than the cost, but no less important. What is the value of any piece of information? What is the relative value of one piece compared to another? Can an improvement in knowledge or an increase in readiness be quantified and priced in terms of dollars, people, time or equipment (resources)? As a pilot in combat, I resented being the measure-of-effectiveness for weapon, tactics or countermeasure improvements. I was pleased that improvements were being pursued in-theater but I was appalled that many pursuits did not occur before the war. On-the-job training is a costly endeavor, as the proponents of TACTS/ACMIs documented in their quest for improved instrumentation thirty years ago.

Total Cost This is nothing more than life-cycle cost. My concern is that standard DoD descriptions of system total costs are often hazy to the average citizen. Obscuration, for many different reasons, often seems the real objective of defense accounting procedures. What resources are really expended to obtain, field, maintain and operate a system?

Latency is conspicuous because of its absence as a characteristic of this instrumentation concept. As stated above in the Simplicity section, information from this instrumentation system should not be used to perform operational functions. One way to insure that preclusion is to withhold any feedback to the participants. Preclusion is not always desirable and

feedback is often necessary to achieve an objective, as is the case for virtual entity insertion into operational displays, with realistic response lags. This system, however, has no feedback and thus no latency requirement.

Concept Description

The description will be short. Experts need the flexibility to respond with their best design. My knowledge of the equipment recommended (some limited and some extensive) and my general research indicates that the proposal is feasible within a reasonable cost and time.

TSPI

The Precision Lightweight GPS Receiver (PLGR) is capable of providing suitable position and time data. It is a differential, precise-code, three-pound unit, in service for nearly five years. Tens of thousands have been delivered worldwide. There are several versions of the PLGR installed on military ground vehicles and used as hand sets by infantry units. PLGRs are used operationally and thus training is available and provided.

PLGRs are "authorized" units, which indicates precise, two-frequency accuracy, free from intentional error manipulation. Differential capable means that the majority of bias errors can be "subtracted" from the position solution using a differential receiver, located on a surveyed position within about 200 miles. Original PLGR requirements stated the ability to perform the differential correction in the unit itself or in a central location after transmission. Both methods require knowledge of the satellites used by PLGR to determine position.

If the Kalman filter (an estimator), pseudo-range measurement, or any element of the differential correction procedures restrict centralized corrections, then the transmission of differential receiver calculations must be made to each individual PLGR. That will complicate but not eliminate the qualities of this proposed concept.

The PLGR was designed to be robust and it appears to be so. Anecdotal evidence indicates that the wire connection to the vehicular antenna may be a weak element, and the vehicular antenna itself can be

shielded by inappropriate personnel actions. These shortcomings, if accurate, can be overcome.

The PLGR uses RS-232 and RS-422 data ports.

PLGR obtains time from the GPS satellites with "atomic-accuracy".

GPS satellites provide worldwide coverage. The goodness (geometry and visibility) of the constellation can vary with earth location and time, affecting accuracy, but terrain features seldom prohibit position or time determination. Some vegetation and urban buildings can restrict reception of the satellites by the antenna but those limitations may not be cost-effective to overcome. Detailed documentation of the scope of the limitation should be determined and reported.

Data Transmission

The objective is universal transmission without unique, fixed infrastructure. That can be achieved by using a digital, satellite-based, cellular communications system.

Iridium is such a system and its satellite segment is now complete. Other systems such as Globalstar will soon follow. They will have different capabilities for data messaging, error correction, modulation, frequency use, PLGR interface, reliability and cost, but all will have the ability to transmit numerous data messages containing position, time, participant

identification and GPS satellite numbers from a cell phone to a central location with sufficient update rates.

That central location should contain the equipment necessary for differential correction, recording and appropriate display of TSPI. It should be portable and movable to any powered location hosting a test or training event. Movement should not require great amounts of time, money or equipment. The central location should also control participant setup and initiation.

Cost

My cost estimate for 1000 cell phone attachments to existing PLGRs is about one to two million dollars. Development, test, and central location cost might be equal to that amount. Operation and maintenance for a year should be also be in the one to two million dollar area. Phone charges for an eight-hour exercise with a thousand participants should be less than a hundred thousand dollars. That is based on continuous operation at twenty cents a minute, a discount for volume on the proposed, published rates per minute.

Conclusion

An instrumentation system suitable for use by testers and trainers during a single event is feasible. It should provide only participant position and associated time.

**Will Facilities be Required? Virtual Testing Shapes
Future of Test Facility Requirements**
Mr R G Pollard and Mr T E Stevenson,
US Army Test and Evaluation Command, USA

**WILL FACILITIES BE REQUIRED?
VIRTUAL TESTING SHAPES FUTURE OF TEST FACILITY REQUIREMENTS⁽¹⁾**

Raymond G. Pollard III, Civilian Deputy,
U.S. Army Test and Evaluation Command
Aberdeen Proving Ground, Maryland 21005-5055, USA

&

Todd E. Stevenson, Associate Chief Engineer,
U.S. Army Test and Evaluation Command
Aberdeen Proving Ground, Maryland 21005-5055, USA

Abstract

Advances in physics based computer modeling, simulation, and visualization are allowing the U.S. Army's Test and Evaluation Command to create synthetic environments for a wide range of systems. These synthetic environments are being used to exercise computer models of new weapons systems in order to plan the subsequent "real-world" testing in an actual facility at a test range. Experience is showing that cost effective test programs are being designed with greater emphasis on the "computer model in synthetic environment" and "hardware-in-the-loop" activities, with less time spent in a "real-world" test range or facility verifying predicted outcomes. Such a trend has enormous implications for decisions on where to place scarce test technology resources in the 21st century. This paper will present a coherent strategy for prioritizing investments in synthetic environments, based on developments in modeling and simulation, coupled with cost-benefit analyses of the synthetic versus real-world tradeoffs. Examples will be presented of the decisions being made today that affect both the management of U.S. Army test ranges and facilities, and the investments that are needed to assure a viable testing capability for the 21st century.

**The Test and Evaluation (T&E)
Environment**

At least for the past five years, the T&E community has experienced an environment of decreasing investment dollars, increasing complexity of weapons systems, and greatly increasing availability of computing power. These factors have led to investment strategies that focus on simulation-based testing capabilities. From a "facilities" standpoint, the shift to simulation-based testing capabilities has profound implications for the investment strategy of the future.

An Emerging Strategy in 1994

At the end of the Cold War, U.S. defense policy was shifting to address lower intensity conflicts with less sophisticated adversaries. While research and development to explore new technologies continued at a fairly constant level, acquisition of new, high technology weapons systems began to come under increased scrutiny from a cost standpoint. Testing and evaluation in the U.S. Army, as a part of the acquisition process, began to experience a downturn in resources. Evidence of the lower priority being placed on investments in T&E was the complete elimination of investment funding for major Army T&E instrumentation in fiscal year 1994, a one-year impact of over \$37M. Investments in all Army T&E instrumentation dropped from a high of \$100M in fiscal year 1992, to \$46M in fiscal year 1994. Overall,

⁽¹⁾ DISTRIBUTION A: Approved for Public Release

the funding for Army T&E dropped 24% from fiscal year 1992 to fiscal year 1994.

In the face of diminishing resources, the real-world, physical testing facilities (such as road courses, launch complexes, and firing ranges) continued to deteriorate. Physical deterioration, which could be kept in check at prior levels of funding through preventive maintenance, emergency repair, and periodic refurbishment, began to accelerate.

At the same time that funding was diminishing, the revolution in computing power was getting underway. At the personal computer level, the "386" processor was replaced by the "486" in 1992, with the Pentium processor following shortly thereafter. Supercomputers were beginning to demonstrate the capability to replicate accurately and cost effectively the physical phenomena associated with complex events in such fields as computational fluid dynamics. The realism of computer generated graphics was increasing quickly with increased computational power. High data rate networks were demonstrating the capability to conduct distributed, interactive simulations across remote locations. Coupled with these advances was a new policy in the Department of the Army to require new major weapons systems acquisition programs to develop and demonstrate a computer-based simulation of the new weapons system in parallel with developing the hardware prototype. Computer aided design and computer aided manufacturing were beginning to form the basis of what is now known as "simulation based acquisition" in the U.S. Department of Defense (DoD). It became evident that the road ahead in military acquisition included exercising computer based simulations of new hardware in a realistic, computer-based environment.

All these capabilities demonstrated that it was becoming feasible to consider a "continuum" of testing facilities. The beginning of the continuum, starting in the earliest stages of new systems development, would consist of

computer models of the new weapon being exercised in a computer-generated environment. For example, with high technology tools, one doesn't need to build a hardware prototype of a new truck to test whether it will have sufficient ground clearance over rugged terrain when fully loaded. A physics-based model of the truck, coupled with a validated terrain model, can be used to explore ground clearances under a great variety of conditions, and incremental re-designs can be investigated easily without the necessity to build successive hardware prototypes. The far end of the continuum would be a real-world test of a hardware prototype on an actual test track late in the engineering development cycle. Even at this "far" end of the continuum, the latest version of the computer model of the hardware could be used in a validated computer-generated environment to predict the "edges" of the performance envelope that needed special attention during the real-world test.

Considering this complex environment in 1993 (diminishing resources, increasing simulation capabilities, deteriorating test facilities, and increasing complexity of weapons systems), for the first time there appeared to be an opportunity to address the critical question of how do we trade off investments in simulation-based testing for investments in traditional, real-world facilities. And, if the tester were to consider a trade-off between a simulation-based test capability and a real-world test facility, on what basis would that trade-off be made?

Critical Decision

In planning for the fiscal year 1995 budget, the U.S. Army developmental testing organization made the critical decision to pursue actively a comprehensive set of simulation-based testing capabilities. This would be implemented by channeling investments heretofore targeted toward real-world test facilities toward simulation-based capabilities. In essence, investment funding would be diverted to "virtual facilities" from

real-world facilities. This was the key decision that was necessary to make the development of simulation-based testing a reality.

The US Army developmental testing organization, known as Army Test and Evaluation Command (TECOM), conducts its technology investment program by prioritizing individual projects proposed by the six test centers. Each year, the test centers (Aberdeen Test Center, White Sands Missile Range, Yuma Proving Ground, Dugway Proving Ground, Redstone Technical Test Center, and Aviation Technical Test Center) submit project descriptions which describe each project in terms of the capability to be provided, the amount of cost avoidance expected to be generated by the project, the safety enhancements to be achieved, and the relative criticality of the project in relation to weapons system acquisition programs. The spending plan for technology investments is developed by integrating the proposed projects from the test centers into a prioritized list, and then funding the investments by beginning at the top of the list and ending with the lowest priority project on the list that can be accomplished within the available investment dollars.

In the investment planning for fiscal year 1995, TECOM stopped the normal prioritization process and added the concept of "supporting a virtual proving ground" to the decision process. The test centers were given the opportunity to label on-going projects as supportive of a simulation-based testing capability, and to propose new projects that would support such a capability. Once identified, the Virtual Proving Ground (VPG)-labeled projects would have added priority in the funding process. The test centers responded with a wide array of simulation-based test capability investments, and the Virtual Proving Ground began to take shape.

In fiscal year 1995, TECOM committed to spend \$8.4M of the total \$26.8M instrumentation budget for projects supporting

the Virtual Proving Ground. Priority was given to projects that would provide a return on investment, in terms of saving more money for the test customers than it cost to build the project. Test centers began to realize that future investment funding for their test center would depend to a large extent on the degree to which they could propose to build valid, cost-saving simulation-based test capabilities. The \$8.4M spent in fiscal year 1995 contrasts sharply with the total of \$4.5M for simulation-based testing capabilities that were identified before the priority scheme was put into place. Simulation-based testing capabilities became the "facilities" of the future, beginning to displace investments in conventional facilities such as firing ranges and test tracks.

The Plan

In the planning for investments to be made in fiscal year 1996, TECOM realized that the concept of simulation-based testing facilities needed a long-term framework. A Virtual Proving Ground Working Group was established, using experts from each of the TECOM test centers, with the goal of producing a strategic plan to guide investments in simulation-based testing. The Working Group defined four categories that would be used to partition new investments in the VPG:

Category A – Projects needed to develop a near term capability (by fiscal year 1998) for the Comanche (the scout / attack helicopter), the Javelin (a man-portable anti-tank weapon), the Crusader (the next generation self-propelled howitzer) or the THAAD (Theater High Altitude Air Defense missile system).

Category B – Projects needed at all TECOM test centers to support simulation based testing capabilities. These were projects such as common simulation tools, data transmission, data reduction, and networking.

Category C – Projects at specific TECOM test centers other than the above in support of Army test programs.

Category D – Projects in support of simulation based testing capabilities being developed by all three Services (Army in conjunction with Navy and Air Force).

Using these categories, TECOM was able to determine the relative contribution of the various projects in relation to the available resources for fiscal year 1996. TECOM funded all Category A projects for fiscal year 1996, and some of the Category B projects, totaling \$15.2M. However, the funding was insufficient to purchase all tools needed across all test centers, and there was no money available for the installation-specific projects or the joint service projects.

In addition to the project-specific resources planning for fiscal year 1996, TECOM was developing the second draft of the Modeling and Simulation Master Plan. The goal of this plan was to achieve TECOM's future testing mission in the "synthetic" world. TECOM would no longer be confined to the test-fix-test mode of engineering development, but would elevate to a model-simulate-test-model mode. The Modeling and Simulation Master Plan set forth a structure for this new testing mission, and a time-line for actions necessary to achieve the structure. The critical benefit of this Plan was the ability for all TECOM staff to comprehend the scope and direction of the initiative to move into synthetic testing; each element of the staff could interpret the initiative in the context of their responsibilities.

The only problem at this point was that the Army's developmental testing funding had just experienced another major decrease in conjunction with overall defense budget cutting, and simulation-based testing was moving out of reach at the very time that the structure was being defined.

The Resources

In early 1996, TECOM had developed a detailed plan of the funding requirements for simulation-based facilities for fiscal year 1997 and beyond. Requirements in fiscal year 1997 were \$14.3M alone. In the DoD budget structure, TECOM is on a partial "trading basis," having to "earn" the direct costs of testing from test customers, and being provided an ever-decreasing yearly stipend for overhead expenses. The funds for direct testing costs are given to the weapons systems project managers as part of the overall weapons system project funding. The project managers can then decide to get testing accomplished either at in-house (TECOM) facilities or at private sector facilities.

Although the funds for direct test costs were in the hands of the project managers, the overhead account allocated to TECOM was not able to keep up with modernization investments needed to build the simulation-based testing capabilities.

TECOM developed a plan to articulate the following logical argument:

If simulation-based test facilities are more efficient than "brick and mortar" test facilities in providing information to test customers, then the direct testing costs borne by the project managers should go down.

If the aggregate of all efficiencies realized in the hands of the project managers exceeds a proposed increase in funding (in the overhead account) to purchase these new facilities, then the DoD has realized a substantial, positive cost avoidance.

Through a detailed analysis of benefits to be gained by each element of the simulation-based testing capabilities, TECOM was able to convince the DoD budget planners that a modest investment in simulation-based facilities would more than justify the expense of acquiring such facilities. In gross numbers,

the simulation-based facilities would cost roughly \$77.5M over a six year period, with total cost avoidances exceeding \$150M. The funding to achieve the simulation based testing capabilities was to come from two sources: 1) a portion of the previously allocated investment budget of TECOM, and 2) a new budget allocation based on the cost avoidance to be realized from simulation based testing. The detailed cost profile (in millions of dollars) was as follows:

Funds previously approved:						
FY98	FY99	FY00	FY01	FY02	FY03	Total
6.3	7.2	3.3	2.7	3.3	3.3	26.1
New funds:						
9.7	8.5	8.7	8.4	7.8	8.3	51.4
Total cost:						
16.0	15.7	12.0	11.1	11.1	11.6	77.5

What's on the Ground

Prior to the FY98 program to fund new simulation-based testing capabilities, a number of on-going projects were forming the basis for gaining confidence in the application of computer simulations to developmental testing. Examples of these projects are as follows:

Aberdeen Test Center – The Fire Control Test Complex at Aberdeen Test Center uses computer guided lasers to generate target presentations on the inside surface of a 100-foot-radius hemisphere. Full scale weapons platforms with integrated fire control systems (for example, the M1A2 Abrams tank and the AH-1 Cobra helicopter) are placed inside the dome and the capabilities of their fire control systems are tested with soldiers operating the weapons systems. Tracking errors can be recorded and analyzed to form a basis for improvements in tracking software and hardware.

White Sands Missile Range – The Smart Munitions Test Suite at White Sands has integrated a super computer with the latest

multiple object tracking radar to demonstrate the capability to "aim" camera coverage of multiple, high speed events associated with submunitions dispensed from high speed rockets and missiles. Typically, these submunitions autonomously detect, identify and track ground targets. Not only can the Smart Munitions Test Suite track and capture all these events, it can also produce a computer simulated visualization of the planned event with sufficient accuracy to allow testers to optimize instrumentation locations and target complexity. This test planning capability gives the Smart Munitions Test Suite the advantage of being able to assist in optimizing these extremely expensive tests. The \$5M initial investment in this virtual firing range generates more than \$5M cost avoidance annually.

Redstone Technical Test Center – The Simulation / Test Acceptance Facility at the Redstone Technical Test Center performs lot acceptance testing on Hellfire missile production lots without actually firing the missile. The missile is an air-to-ground, radar guided missile fired from the Apache helicopter. In this facility, a fully capable, "live" missile is placed in a test fixture where it is free to move through six degrees of freedom. Target signatures are presented to the radar seeker, which in turn generates commands to the missile's control surfaces. As the control surfaces move, the test fixture computes the resulting dynamic forces on the missile airframe and translates these into accelerations and displacements of the test fixture. Simultaneously, the target signatures being presented to the radar seeker change position corresponding to the seeker's movements as a part of the missile airframe. In effect, the missile "flies" to the target with all of the guidance, control, and dynamic functions performed exactly as in a real flight. The only functions not performed are the rocket motor burn and the warhead explosion.

If all functions are nominal, the missile is returned to the stockpile as a fully capable round, rather than having been expended in a live firing. The initial investment of \$6M for this facility returns over \$8M per year in cost avoidance in terms of missiles that would have been expended, but are rather returned to the stockpile as fully capable.

Testing and Science & Technology (S&T) Partnership - TECOM is partnering with the Army Research Laboratory and the University of Arizona to develop the Hardened Subminiature Telemetry and Sensor System (HSTSS) which is a physics-based model for examining munition and weapon system performance. The HSTSS is a new instrumentation package that fits into the base of an artillery or tank projectile, and transmits data on the accelerations being experienced by the projectile while in flight. These data can be translated into flight attitudes of the projectile, which indicate whether the projectile is flying "on-course." The HSTSS will be used to examine the expected performance characteristics of tank and artillery projectiles, as well as aid in data analysis of the Crusader test program. Performance will be predicted through the modeling of the new charge system and the 30 combinations of "fuse-to-projectile."

Dynamic Infrared Scene Projector (DIRSP) – TECOM is developing the DIRSP to provide real-time, dynamic, complex, in-band infrared (IR) energy into the entrance aperture of the Army's 2nd generation forward looking infrared (FLIR) and missile IR seeker sensor subsystems in a laboratory. The DIRSP presents the target scene as an infrared "picture" varying in real-time with the attitude of the missile as it flies to the target. The DIRSP will initially support the Improved Target Acquisition System, Improved Bradley Acquisition Subsystem, Javelin missile IR seeker subsystem, and

the Comanche Electro-Optical Sensor System.

Virtual Range – TECOM formed a team with members from several Army organizations to develop unique procedures to collect multispectral calibrated target and background signatures, integrated with range and target characterization databases, into a virtual synthetic scene suitable for use with a number of simulation applications. End capabilities will consist of a core set of 3-dimensional infrared target and background models representing the desert, arctic, temperate, and tropical climates. The end product of these efforts will directly support the Javelin/Follow-on-to-TOW development and performance assessments.

TECOM anticipated the need to be able to validate the efficiencies being realized throughout the acquisition of simulation based testing capabilities. One could reasonably expect that the Department of Army would be very interested in seeing that over \$77M in investments was being put to use for testing capabilities that meet the customer's requirements with increasing efficiencies. That is why the plan for the Virtual Proving Ground included a timetable for assessing the Early User Utility of these simulation based testing capabilities. Simulation based facilities to be acquired over the planned period are prioritized so that projects with a large cost avoidance in relation to investment cost, coupled with a relatively short acquisition time, will be completed early in the overall program. To the extent that these projects can be identified, funded and completed, this approach assures that the funding allocation can be "protected" throughout the project based on early, successful elements.

Beginning this summer, Early User Utility assessments of the Virtual Proving Ground will be performed at TECOM test centers and contractor facilities. To assure objectivity,

these assessments will be conducted by an Army systems analysis organization independent of TECOM. Actual, working simulation-based testing capabilities will be assessed for their utility at the following locations:

Sikorsky Aircraft Corporation – TECOM has partnered with the project manager for the Army's Comanche helicopter program to build the Flight Test Support Simulator (FTSS) at the manufacturer's facility. This system will allow pilots and aircraft engineers to design the test program for the actual flight article, test weapons system engagements via the infrared weapons guidance and control systems, investigate flying qualities under adverse conditions, and evaluate human factors and subsystem integration.

JAVELIN / Follow-on-to-TOW – TECOM is working as a part of the Follow-on-to-TOW acquisition team to develop an extensive Simulation Test and Evaluation Plan to support the program from early development throughout the life cycle. The simulation-based testing capabilities will include a combination of fully computer-based test simulations as well as hardware-in-the-loop simulations. The involvement of TECOM in this acquisition program will serve as a "pathfinder" to demonstrate how future acquisition programs can integrate modeling and simulation early into the development process to reduce cost, risk and development time.

Facilities Decisions for the Future

The emerging experience with simulation-based testing capabilities has profound implications for test facilities of the future. Experience is showing that a plan to shift toward agile, re-configurable simulation-based test capabilities can compete successfully with conventional investments in traditional launch complexes, road courses, and firing ranges.

An environment of either constant or decreasing resources, as is likely in the next five to ten years, will continue to exert pressure for more cost avoidance and efficiency gain for each unit of investment in new facilities.

Coupled with the need for investment efficiency is the recognition that increasingly complex weapons systems are driving up the "cost per test event." This has been evident in missile systems and aircraft for some time. However, with the advent of "brilliant" submunitions and projectiles, the "cost per test event" for previously considered "conventional" weapons testing (tank main armament and anti-tank weapons, for example) are becoming prohibitively expensive. Again, this cost per test event in real-world testing applies pressure toward developing simulation-based testing capabilities where literally hundreds to thousands of test events can be simulated for the expense of one live shot.

Needless to say, the advances in computer technology (including hardware, software and networking technologies) are bringing the objective of valid, physics-based simulations closer to reality. Energetic events such as detonation of high explosives can be visualized and studied using computational fluid dynamics. In designing their latest vehicle engine, Chrysler Corporation used computer simulations to investigate the sound of over two hundred intake manifold designs before ever casting the first article. (And this was done with technologies available over two years ago.) Advances in computer aided design and computer aided manufacturing are assuring that simulation-ready, computer-based prototypes will be produced as a matter of course in the development of new military systems.

All of these vectors point toward increased movement in the direction of increased investments in simulation based testing capabilities.

Certainly, real-world test facilities have a place in the overall future testing infrastructure. Real-world tests will continue to be needed in the mid-future to validate the “edges” of the performance envelope, and to confirm that the physics-based models can predict accurately the real-world performance. However, it is no longer the case that one can ask whether a real-world test capability can be replaced at least in part by a simulation-based test facility. It is becoming a question of “when.”

Changing Requirements for Aerial Targets
Mr J K Buck and Dr J N Towing,
Defence Evaluation and Research Agency, UK

CHANGING REQUIREMENTS FOR AERIAL TARGETS

Mr J K Buck

Airborne Instrumentation

DERA Aberporth

Cardigan, Ceredigion,

Wales. SA43 2BU

e-mail jkbuck@dera.gov.uk

Dr J N Towing

WX3 Department

DERA Fort Halstead

Seven Oaks, Kent

England. TN14 7BP

Abstract

With the increasing sophistication of new weapon systems the overriding requirement for aerial targets, is that they should be realistic: i.e. they should have the same signature, size, shape and performance of the threats that they are replicating.

In many cases the only way all the above criteria can be met simultaneously is by effectively replicating the threat itself, for example the use of full scale drones. This approach although very thorough is rather expensive. If however only a limited number of target characteristics are required it becomes possible to use cheaper alternatives, such as enhanced sub scale drones and/or towed targets. The types of enhancement required include thermal and radar cross section augmentation.

The signatures of the present generation of sub scale drones and towed targets, both IR and radar augmented versions, are unrepresentative of the threats that are now being considered by weapon system designers. This short coming is particularly prominent when weapons fitted with IR imaging seekers are being tested, because these targets have reduced spatial dimensions and, in the case of towed targets, consist of a single point source of radiation. The seeker could identify this small point as a decoy and ignore it, and start searching for another target, possibly finding the towing aircraft. A similar situation exists for weapons fitted with radar seekers, which may look for effects such as scintillation, glint and engine modulation

rather than just the largest return.

This paper describes the various augmentation techniques available and under development by Airborne Instrumentation, T&E Ranges Sector, DERA Aberporth, and WX3, Weapons Sector, DERA Fort Halstead, to enhance sub scale drone and towed targets in an attempt to provide realistic representations of typical threats.

Introduction

Airborne Instrumentation (AI) is a Department within the Test and Evaluation Ranges Sector of the Defence Evaluation and Research Agency (DERA) responsible for the enhancement and augmentation of target system, primarily aerial but also to a lesser extent sea and land. Some of the areas currently under investigation include; GPS and GPS/INS for both position recording and control, miss distance scorers both scalar and vector and, the subject of this paper, IR (in collaboration with WX3) and radar augmentation.

AI is based at the DERA Aberporth Range, on the West Wales coast and provides, a service to several DERA Ranges distributed across the UK as well as to Ministry of Defence (MoD) and external customers.

With advances in modern weapon seeker technology it is becoming more and more important to provide targets that accurately represent the signatures of true threats. This requirement exists equally for Infra-Red (IR) and Radar seekers. This paper has been

written to give an insight into the problems associated with achieving this and some of the solutions currently being investigated by AI and WX3.

Infra-red

The Requirement

Aerial targets are required to fulfil a number of uses - for missile practice, gunnery practice, missile development, warning system development, and many other applications.

The constantly increasing levels of sophistication in the design of weapons and other systems for air attack and defence requires a variety of targets for the safe testing of prototype devices and for weapons practice. Targets are not only being enhanced using on-board devices to increase their own infrared signature but with current and future missile systems having increasingly more advanced counter-countermeasure algorithms to reject expendable IR decoys, it is also necessary to enhance the aerial targets with flare dispensers.

To a certain extent the development of air targets is reactive rather than pro-active (as with countermeasure development), especially in the case of missile seekers, where tracking and acquisition algorithms may be sensitive, and information regarding what may be suitable as a target is not readily available.

In addressing the area of IR enhancement of aerial targets several points need to be taken into account. Firstly the technique to be used in obtaining radiant emission - for instance whether an energetic material is more suitable than electric means. Secondly whether the target is required for a single presentation or for multiple presentations. Thirdly the type of materials to be used for heating - there are a multitude of pyrotechnic compositions as well as other energetic materials available. Fourthly the type of emission required - is a hot point source or a large area source required, or just an increase of a few 10s of

degrees over a small area of the target? Finally one needs to consider enhancing a target by using expendable flares, which greatly increases the usefulness of the target in testing seeker CCM systems.

Even with an initial design/requirement in place there are many problems associated with the development of an IR enhanced target, especially windspeed that can have a drastic effect on IR emission.

The remainder of this section will address these points and discuss their association and impact in aerial target IR augmentation design.

Solutions

IR Emission Enhancement Techniques

With towed targets having no engines and most model drones having smaller signatures than a realistic target, all of the towed targets, piston engine drones, and some of the turbojet drones need enhancing to give a more representative signature.

There are two main means of providing IR augmentation or enhancement, by use of energetic materials and by electrical means from heaters. Both are discussed further below.

Energetic materials There are several different energetic materials used for target enhancement and each has distinct characteristics that make it suitable to specific types of augmentation, the following table gives examples of some of the more common materials and possible applications where they might be used.

Family	Material	Characteristics	Primary Use
Flammable & Pyrophoric liquids	Hydrocarbon burners	IR emission from heated gauze	Enhancer no plume
	Alkylaluminiums	Specific IR emitter of Kerosene	Enhancer Extended plume
Pyrotechnics	MTV	Grey body emitter 2000°C	Enhancer or expendable (IRCM)
	Specific emitters	Spectral enhancement in the vis/near IR	Enhancer for specific EO systems (e.g. trackers)
	Thermite	Grey body emission - no flame plume	Enhancer/Expendable
	Spark generators	Large area of IR emission	Enhancer/Expendable
	Pyrotechnic /propellant mixes	Specific IR emitters - lower energy than MTV	Expendable

Table 2. Emissive Materials, their Characteristics and Possible Uses.

From the table it can be seen that there are two distinct families of energetic materials; combustible liquids and pyrotechnic materials. These are discussed in more detail in the following sections.

Combustible Liquids The advantages of using liquid systems for IR sources are that they can be turned on and off as required, whereas a pyrotechnic is a once only event. Flammable liquids offer a means of obtaining more spectrally selective emissive source by either the primary emission from the reaction products or by secondary emission from a gauze. The liquids may be split into two types, those that are flammable only with a source of ignition and those that are spontaneously flammable on contact with air. These latter pyrophoric liquids have been discussed and tested previously for target applications and will not be expanded upon here.

Liquids have the advantage of giving specific emission and energy on tap, although have the disadvantages of lower densities (less energy available per unit mass) than solid pyrotechnic mixes and susceptibility to fast airstreams.

Liquid combustibles are commonly used for IR augmentation as fuel for plumers and burners. Plumers and burners in current use are fuelled by propane gas or by jet fuel supplied from the drones fuel tank or from an extra tank in the fuselage. The plumers use

mainly jet fuel and produces a flame out of the rear of targets or out of wing-tip mounted pods fitted on target drones. Burners generally use propane gas that is used to heat up a metal plate or gauze to produce a hot metal emitter. The plumers can be further enhanced by using an IR Pyrotechnic slurry containing, for example an ionic oxidant, an organic solvent and a metal fuel such as magnesium.

Pyrotechnic Materials The most common method of pyrotechnic enhancement used is by addition of flares, particularly on the piston engine targets, which have a very low signature. Flares produce hot sources and in towed targets they generally have a larger signature than the towing aircraft. An alternative method is to use a thermite composition in a crucible. The thermite is ignited and heats the crucible in which it is enclosed, this will produce a hot source with little or no flame apparent to an external observer. These pyrotechnic systems are discussed later.

Pyrotechnics radiate energy in all wavebands throughout the UV and IR spectral regions depending on the nature of the compositions.

Pyrotechnic Thermite Thermite materials have been used extensively in the pyrotechnic industry as a method of producing ceramics and hot solid reaction product without generating many gaseous species. The target application is mainly concerned with using thermite material to act as large thermally emissive beacons for towed targets and missile tracking beacons.

The characteristics of thermite reactions are that; they produce small quantities of gaseous products; they can exhibit high reaction temperatures - up to 3000 °C; they produce molten or solid slag; they are often difficult to ignite, with ignition temperatures sometimes above 800 °C; and they generally have a high density, due to the metal oxides used. As a means to provide a hot emitting area they are very useful although they need to be encased in a suitable container with regard to the

temperature of reaction of the thermite, i.e. the melting point of steel is around 1500 °C which limits some of the thermites that can be used. The emission from the device is dependent on the heated area of casing material, the emissivity of the surface (this can change if oxidation occurs at high temperature), and the heat flow characteristics of the container (thickness and mass of metal etc).

The thermites also find use in pyrotechnic batteries where they ignite to melt the electrolyte and provide electrical power. These batteries get very hot themselves (several hundreds of degrees) and could be used as a power source for other electrical means of heating.

Spark Generators Some pyrotechnics produce high melting point, solid, reaction products. Titanium is an example producing large particles of titanium oxide in the pyrotechnic plume. The higher heat capacity of these particles compared with vapour phase reaction products result in a long low temperature plume from the target which, although low in total energy, can be easily observed with thermal imaging equipment

Expendable devices The use of targets for missile testing requires the use of expendable IR countermeasures to realistic test seeker counter countermeasure algorithms. The most common stores used for this are all based on MTV composition.

Experimental payloads can be designed for all of these countermeasure cartridges so that the total energy, the distribution of energy spectrally and spatially, and the burn time of the expendable store can all be tuned to any particular target requirement.

Electrical Depending on the power available, an electrical heater element or bulb can be used for an IR source. Xenon lamps can be used as a source of near IR energy and could be focused to improve their irradiance in a particular direction.

The use of electric means is limited to low levels of heating as power is always limited and the cooling by windspeed very efficient.

Problem Areas regarding IR Enhancement

Static / dynamic performance One of the biggest problems regarding the design and development of IR sources for aerial targets is the difference that occurs in infrared emission between a static device and a device subjected to high windspeeds. Windspeed is incredibly effective at cooling heated surfaces and the hot exhaust products from pyrotechnic flames and hydrocarbon. This is not a matter of a losing 10% or so of the energy but reducing the energy of emission by a factor of 8 or so. For instance a flare for a towed target might give out a couple of kW sr-1 in the IR region when burnt statically but this could be reduced to a few hundreds of W sr-1 when combusting in a 300 knot airstream. This is due to the rapid cooling of the hot reaction products by the airflow.

Another problem caused by the airflow is the restriction on the physical area of emission from a plume or pyrotechnic flame. Under static air conditions a pyrotechnic can be designed to emit hot material over a large area, but in a windspeed the reaction products are swept away with the airflow around the target.

Wind tunnel testing It is possible to carry out wind tunnel trials to assess this windspeed effect. DERA has a facility suitable for the safe firing of combustive materials. It is based at DERA at Boscombe Down and is capable of windspeeds of up to 300 knots.

Wind tunnels can also highlight problems with design associated with the plume from a target. The re-circulation of air around the back of a target where flares or other IR augmentation devices are often placed can cause hot plume material to damage the surrounding fabric of the target and can even cause parasitic ignition of other flares.

Summary

Depending on the requirement it is possible, using a combination of the techniques discussed, to provide suitable IR target augmentation and expendable flares, for CCM evaluation. However one requirement that can not be fully met by the means discussed is the evaluation of imaging seekers. To fully evaluate these systems a target must not only provide realistic IR emissions but also replicate the size and shape of the threat. At present this can only met by means of full scale drone targets. However IR augmentation of sub scale targets and tows might offer a cheaper means to test and evaluate existing and future weapons systems ahead of these more expensive trials.

RADAR

The Requirement

The existing aerial Radar targets use on DERA Ranges are enhanced using either luneburg lens or Semi-Active Radar Targets (SART). The luneburg lens provides a passive reflector that returns a large percentage of the incident energy back to the illuminating Radar. The SART operates slightly differently in that it receives the incident energy and, by means of microwave electronics, amplifies it before re-transmitting. Both systems give the target a larger Radar Cross Section (RCS) than it would otherwise have had and also a larger RCS than the tug aircraft. However the return signal is just a larger version of the incident and is not what would be returned by a real aerial threat. Real aircraft modify the return signal by introducing effects such as scintillation, engine modulation and glint.

Scintillation A complex target such as an aircraft may be considered as a number of independent scattering elements. The echo signal can be represented as the vector addition of the contributions from the individual scatterers. If the target aspect

changes with respect to the illuminating radar, as might occur because of motion of the target or turbulence, the relative phase and amplitude relationships of the contributions from the individual scatterers would also change. Consequently, the vector sum, and therefore the amplitude and phase, change with changing target aspect.

Glint Changes in the target aspect with respect to the illuminating radar can cause the apparent centre of radar reflections to wander from one point to another. In general the apparent centre of reflection might not correspond to the target centre. In fact, it need not be confined to the physical extent of the target and may be off the target a significant fraction of the time. This apparent random wandering of apparent radar reflection centre is commonly called target glint and results from the tracking radar receiving the vector sum of the echoes contributed by the individual scattering centres of the target.

Engine Modulation The radar echo from aircraft is modulated by the rotating propellers of piston and turboprop engines, Propeller Engine Modulation (PEM), and by the rotating compressor or turbine blades of jet engines, Jet Engine Modulation (JEM). A similar effect can also be seen when looking at helicopters, the modulation being caused by the rotor blades, Rotor Engine Modulation (REM).

Engine Modulation results in a number of frequency offset returns, the offset being relative to the speed of the engine, perhaps ten to twenty kilohertz for jet engines.

To provide a realistic radar target it is necessary to emulate these effects.

Solutions

DERA have a facility based at DERA Larkhill that can provide dynamic RCS data directly from the target of interest, simultaneously measuring amplitude and phase components. This dynamic radar signature data acquisition

system consists of an industrial computer with custom interface boards and a phase/doppler interface drawer. This system interfaces with a radar after the mixer-pre-IF and is transparent to the host system.

This system has been used to measure a wide range of aircraft over a wide range of angles, on some aircraft nearly 4π steradians (near spherical coverage). This data has been used to determine what returns are required from a towed target to realistically replicate a threat aircraft.

Semi-Active Radar Target (SART) The primary radar towed target used on DERA Ranges is the SART. This tow is streamed behind an Unmanned Air Vehicle (UAV). When activated the SART receives the illuminating radar energy through a receive antenna mounted either on the front, for forward looking SART, or the side for sideways looking SART. This energy is passed through a microwave amplifier where its power is greatly increased. This signal is then fed to a second antenna where it is re-transmitted. As with the receive antenna this is mounted either on the front or the side depending on the orientation of the SART.

The SART target provides a large RCS return, however its output waveform is identical to that falling on its receive antenna but at a higher power level, none of the effects produced by real aircraft are introduced. This target has been adequate for previous and existing generations of radar guided weapons. However as signal processing and seeker head technologies advance it is becoming more important to provide greater realism, both to evaluate the weapons performance and to protect the tug aircraft.

Modulated Output Semi-Active Radar Tow (MOSART) A development programme has been set-up to look at how a simple SART can be modified to provide a more realistic representation of a threat aircraft. The initial stages of this programme involved the use of the DERA radar signal processor to assess the

radar returns from a selection of aircraft over a wide range of aspect angles. The data gathered from these trials was analysed and a data set of generic characteristics was produced.

The effects that AI are most interested in reproducing are scintillation and engine modulation, it was determined at an early stage that glint would be virtually impossible to reproduce using the single radiating source of the MOSART.

A feasibility study was conducted to assess potential techniques applicable to the task. As a result it was decided that simple modulation and mixing technologies would be used. The various effects were then implemented in the following way:

Scintillation The effect of scintillation was reproduced by amplitude modulating the output with a randomly generated signal prior to re-transmission. It should be possible in future iterations to replace this random signal with the measured characteristics from a real aircraft. The phase component apparent in true scintillation is not reproduced, however future work will investigate the possibility of its inclusion.

Engine modulation The effect of engine modulation is reproduced by the addition of frequency offset returns. This is achieved in one of two ways; The first involves the generation of frequency offsets and their addition to the main output. Dedicated electronics are required to generate each of the frequency offsets. This technique works well but requires a lot of electronics to truly reproduce the effects of engine modulation. The second technique uses basic modulating and filtering techniques to produce the required effects. The modulating signal currently used is simple and provides a number of fixed frequency offsets at different amplitudes. Future versions will use more complex modulating signals, derived from the measured data and advanced signal processing techniques, to replicate the signature of actual

aircraft, including rotary aircraft.

Glint It was mentioned earlier that glint could not be produced with a modified SART alone. However some preliminary tests were conducted using a MOSART and a passive corner cube reflector separated by several metres. By varying the amplitude of the MOSART output it was possible to make the tracking radar move back and forth between the two sources. This is not true glint but does give a similar effect. This technique may be of use and will be the topic of a future work.

Summary

A number of trials have been conducted using the MOSART both static in an anechoic chamber and in flight using the DERA radar signal processor. Although full analysis of the results has not yet been completed, preliminary findings show the MOSART radar return to be similar to that of a real aircraft and AI are confident that within the near future a low cost realistic radar target will be available for weapons test and evaluation trials.

Conclusions

The design of targets tends to follow requirements rather than be pro-active, however it is important that background technology be kept up to date to be ready to respond as quickly and cost effectively as possible to new requirements.

Sub scale drone and towed targets can offer a cheap means of testing either prototype countermeasures, or novel seeker systems and algorithms, and, by using a combination of enhancement and decoys can be used to assess missile effectiveness. Certainly they might offer a cheaper means to test and evaluate existing and future weapons systems ahead of more expensive full scale drone target trials.

The work being undertaken by WX3, DERA Fort Halstead and AI, DERA Aberporth is aiming to meet these requirements and if not able to do away with the need for full scale targets to limit the amount of times they are required.