

JPRS-CST-87-028
25 JUNE 1987

212017



**FOREIGN
BROADCAST
INFORMATION
SERVICE**

JPRS Report

Science & Technology

China

DTIC QUALITY INSPECTED 2

19990113 050

REPRODUCED BY
U.S. DEPARTMENT OF COMMERCE
NATIONAL TECHNICAL
INFORMATION SERVICE
SPRINGFIELD, VA 22161

27
122
A06

25 JUNE 1987

SCIENCE & TECHNOLOGY

CHINA

CONTENTS

APPLIED SCIENCES

Digitized Transformation of Area Array CCD (Tao Deyuan, et al.; SICHUAN DAXUE XUEBAO, 1986)	1
Microwave Propagation in Country (Hou Dahan; TONGXIN XUEBAO, No 1, Jan 87)	9
Programmable A/D Amplifier Interface for S-100 Bus (TIANJIN KEJI XIAOXI, No 4, 15 Apr 86)	21
Program Controlled Telephone Software System (Gu Manhong; TIANJIN KEJI XIAOXI, No 4, 15 Apr 86)	23
Computer Control for Post-Rolling Heat Treatment (TIANJIN KEJI XIAOXI, No 4, 15 Apr 86)	26
Computerized Control for Liquid Gas System Described (Chen Yongyou; TIANJIN KEJI XIAOXI, No 4, 15 Apr 86)	29
New Chinese-Character Operating System Developed (Zhan Yingmin; TIANJIN KEJI XIAOXI, No 4, 15 Apr 86)	31
Computerized Cadre Personnel Files Management System (TIANJIN KEJI XIAOXI, No 4, 15 Apr 87)	32
Microcomputer Enterprise Management System Developed (Zhang Yiming; TIANJIN KEJI XIAOXI, No 4, 15 Apr 86)	34

Computerized Design System Used for Transmission Design (Li Hua; TIANJIN KEJI XIAOXI, No 4, 15 Apr 86)	36
Programmable Controller Situation Described (TIANJIN KEJI XIAOXI, No 4, 15 Apr 86)	38
Circuit Design, Analysis Software Developed (TIANJIN KEJI XIAOXI, No 4, 15 Apr 87)	42
China's 1st Matrix Resin for Composites Introduced (Sun Shuchun, Yang Biao; SHENZHEN DAXUE XUEBAO, No 3, Sep 86)	44
New, Fast Thinning Algorithm for Binary Digital Images (Chen Yuxin, et al.; CHONGQING DAXUE XUEBAO, No 3, Sep 86)	53
 LIFE SCIENCES	
New Complex Type of Abnormal Hemoglobin: Hb G-Chinese Combined With Hb J-Bangkok (Zeng Yitao, et al.; SHENGWUHUAXUE YU SHENGWUWULI JINZHAN, No 3, May 86)	62
Primary Structure Analysis and Functional Study of Case With Hb Lille (Lu Yiqin, et al.; SHENGWUHUAXUE YU SHENGWUWULI JINZHAN, No 3, May 86)	64
Effect of Estrogen on High Density Lipoprotein Metabolism in Rats (Chen Qi, et al.; SHENGWUHUAXUE YU SHENGWUWULI JINZHAN, No 3, May 86)	66
Insulin Receptor Changes During Reticulocyte Maturation in Culture (Zhu Shangquan, et al.; SHENGWUHUAXUE YU SHENGWUWULI JINZHAN, No 3, May 86)	68
Insulin Receptors on Reticulocyte Membranes (Zhu Shangquan, et al.; SHENGWUHUAXUE YU SHENGWUWULI JINZHAN, No 3, May 86)	69
Chemical Modification of Superoxide Dismutase and Properties of Modified Enzyme (Wu Yun, et al.; SHENGWUHUAXUE YU SHENGWUWULI JINZHAN, No 3, May 86)	70
 NATIONAL DEVELOPMENTS	
Technical Transformation of Iron Mines (Wang Shaoliang, Fan Yongwen; JISHU KUANGSHAN, No 11, 20 Nov 86)	71

Progress in Remote-Sensing Technology (Yang Shiren; XIANDAIHUA, No 1, Jan 87)	82
Value of Space Remote Sensing Emphasized (Wang Xiji; XIANDAIHUA, No 1, Jan 87)	88
Satellite Ground Station Prepares for Operations (Wang Xinmin; XIANDAIHUA, No 1, Jan 87)	90
Development of S&T Consulting Industry Described (Zou Yi'an, Chen Puyuan; XIANDAIHUA, No 1, Jan 87)	93

PHYSICAL SCIENCES

Nice-Compactness on L-Fuzzy Topological Space (Peng Yuwei; SHUXUE XUEBAO, No 4, Jul 86)	98
Expansion of $\int U U$ in Fourier Series and The Sea Botton Drag Coefficient C_D in the Bohai Sea (Zhou Meng, Fang Guohong; HAIYANG YU HUZHAO, No 1, Jan 87)	104

/7310

DIGITIZED TRANSFORMATION OF AREA ARRAY CCD

Chengdu SICHUAN DAXUE XUEBAO (ZIRAN KEXUE BAN) [JOURNAL OF SICHUAN UNIVERSITY (NATURAL SCIENCE EDITION)] in Chinese Vol 1, 1986 pp 111-116

[Article by Tao Deyuan [7118 1795 0337], Luo Daisheng [5012 0108 0581], and Ma Daixing [7456 0108 5281]; paper received 10 October 1983]

[Text] When using computers to process real images, it is necessary to transform the real image into a digitized image with which it corresponds. A block diagram of the structure to complete this task is given in Figure 1.

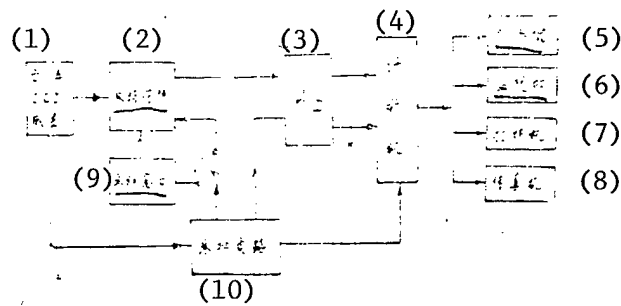

Figure 1. Block Structure of an Area Array CCD Image Digitized Transformation

Key:

- | | |
|-------------------------|----------------------|
| 1. Area array CCD image | 6. [Illegible] |
| 2. [Illegible] | 7. Printer |
| 3. A/D converter | 8. Facsimile printer |
| 4. Computer | 9. [Illegible] |
| 5. [Illegible] | 10. Sampling circuit |

Sample Frequency

The national television standards specify that in the sweep of an entire image there are a total of $N' = 625$ rows and $M' = 944$ columns. Thus a complete image has $w' = N' \times M' = 590,000$ picture elements. Supposing the image elements to be composed of w' black and white checked squares as shown in Figure 2, then two small square picture elements outputting a black and white check require a square wave and the total number of square waves is $w'/2 = 295,000$. If the

image is presented 50 times in 1 second, i.e., the frame frequency is 50Hz, the number of square waves each second is

$$w'/2 \times 50 = 14,750,000$$

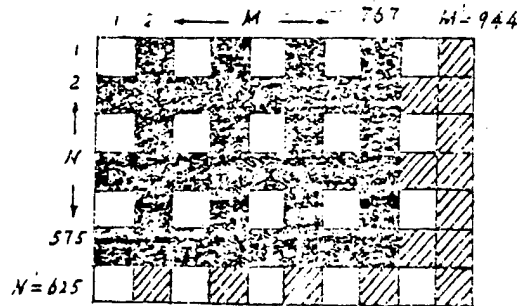

Figure 2. Distribution of w' Picture Elements

This is the highest operating frequency of the image signal. A frequency band this wide is without practical value so means must be found to lower it. If we reduce the number of rows, N' , we must reduce the picture elements in the picture plane. Thus by first lowering the frame frequency to 25Hz and then, so that the image does not produce scintillation, dividing each frame into odd even fields each frame can still be transmitted at 50Hz (because the human eye has vision persistence, when transmitting the even numbered field (row) the image of the odd numbered field (row) remains in the mind). Then the highest operating frequency is

$$f_{max} = \frac{w'}{2} \times f_s = 7.375 \text{ Mc}$$

and the frequency response characteristics are shown in Figure 3. Again, according to the (Naikuisite) sampling theorem, the sampling frequency is

$$f_c \geq 2f_{max} = 14.75 \text{ Mc}$$

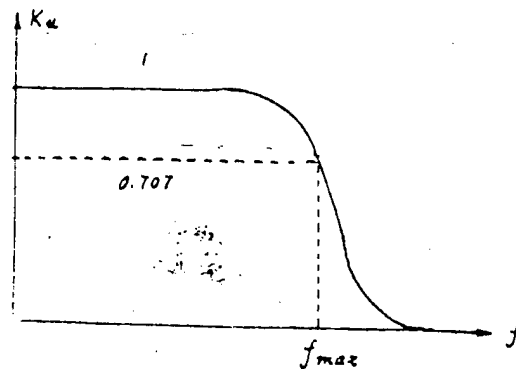

Figure 3. Frequency Response of the Image Signal

The width height ratio of CCD images is mostly 1:1 and each row of image elements must be designed to be an integer power of 2. In order to obtain an image with the same quality as a television camera, each row of picture elements is taken as $2^9 = 512$. If, as before, we use television field frequency and row frequency, then the sample frequency is

$$f_s = \frac{512 \text{ (个)}}{52 \text{ (}\mu\text{s)}} = 9.846\text{Mc} \approx 10\text{Mc}.$$

Sample Mode

From the sample frequency we know the time for transmission of one picture element is $0.1 \mu\text{s}$. If we want to transform the picture elements grey scale into numbers and use a computer to carry out processing, then we want the conversion time of the A/D transformer to be less than $0.1 \mu\text{s}$. Under ordinary circumstances this is difficult to achieve. Therefore the only way to go is to use the method of having each row send a picture element and each frame send a column of picture elements to do sampling of the image. That is, in the first field of the i th frame select the i th picture element in rows 1, 3, 5, 7, 9 and in the second field select the i th picture element in rows 2, 4, 6, 8, 10. This way in the entire i th frame (both fields) we have completely selected the i th picture element in each row as shown in Figure 4.

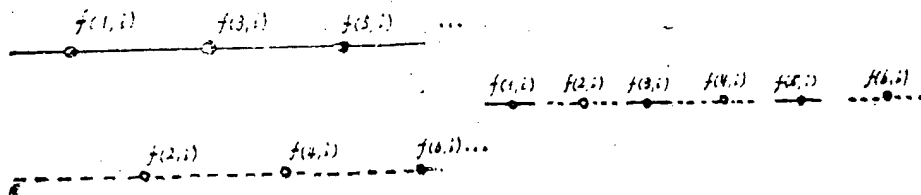

Figure 4. Alternate Row Image Sampling

The digitized image obtained with this mode of sampling is a transposition of the original image. For the concrete situation see Figure 5. According to this method, if we want to sample all 512 columns it will require 512 frames and the time needed will be $t = (2 \times 20\text{ms}) \times 512 = 20.48\text{s}$.

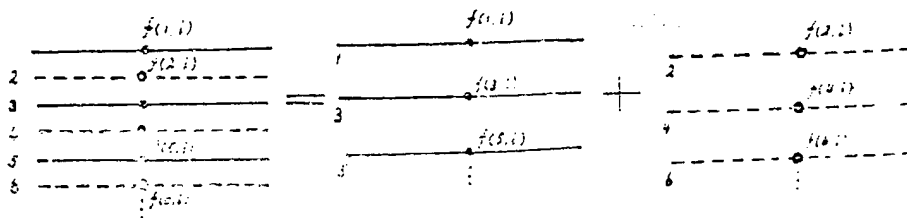

Figure 5. The Sampled Image Is a Transposition of the Original Image

In order to realize the task outlined above, we must design a suitable sampling output pulse, i.e., one that only selects the i th picture element of every row in the i th frame. Therefore the relationship between the frame pulse M , each

row picture element pulse B, and the sampled output pulse F is as shown in Figure 6 and is called same address.

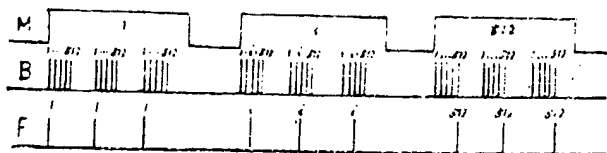

Figure 6. Same Address Circuit Wave Form

From this we see that only when the frame number, M, and the row picture element, B, are the same is the sampling pulse, F, output. If we adopt this sort of "fast sweep, slow sampling" mode (each row selects one point and each frame selects one column) then the field by field sampling frequency is reduced to

$$f_s \geq 2 \times \frac{1}{64Ms} \approx 23 \text{ Kc}$$

and the alternate field sampling frequency is lowered to

$$f_s \geq 2 \times \frac{1}{2 \times 64Ms} \approx 16 \text{ Kc}$$

Counting Circuit

From the three wave forms in Figure 6 we see that when $M = i$, even though B can change from 1 picture element to 512 picture elements, only when $M = B = i$ does $F = 1$. Obviously, the transformation process of $M = i$ ought to be denoted using a frame counter. By the same principle, for the $B = i$ transformation process we also ought to use a sample clock counter. A model of this sort of circuit is given in Figure 7 with each counter composed of circuits using nine-place binary.

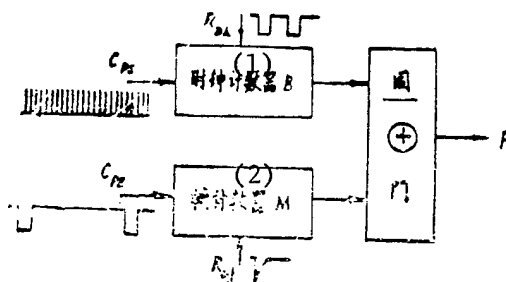

Figure 7. Basic Model of the Image Sampler Circuit

Key:

1. Clock counter B
2. Frame counter M

Image Sampler Control Circuit

For an entire 512 x 512 area array CCD we can use its horizontal driven three phase pulse $\phi_{III} = 10\text{Mc}$ as the sample clock pulse C_{ps} . In order to make the CCD output picture element able to match up closely with the sample output pulse, a traveling reset pulse, R_{Dh} , ought to be obtained by the NOT of the CCD field synchronous pulse and the NAND of the CCD traveling synchronous pulse after going through a 12 μs delay. The frame counter pulse, C_{pz} can be obtained using the NOT end of the CCD field synchronous pulse after frequency division and, after NANDing with the original field synchronous pulse, controls the frame reset and opening of the sampling gate.

In order to make it so that after initiation, the circuit is able to sample completely one frame of the image, its continuous operation time ought to be bigger than $(40.3\text{ms}) \times 512 = 20.6\text{s}$. Consequently we must use a 20.6s control circuit.

Before initiation we ought to close the sampling gate. The close signal can be introduced into the circuit in an appropriate place. At the instant of initiation, we ought to let the leading edge of the first frame go and open the sampling gate and make the frame counter reset once. Just at the instant that the image is completely sampled, not only should the sampling gate be closed but we should also close the input C_{pz} of the frame counter. Consequently, we must also set up a frame gate closer. For the same reason one should also be set up for sampling clock counter. The sampler circuit is as shown in Figure 8 and the wave form at various points is given in Figure 9.

Sample Window

With the image of one N row by M column frame quantified into a 2^K grey scale, the computer storage required is $q = N \times M \times K$ bits. If $N = M = 512$, $K = 8$ then $q = 2,097,152$ which is difficult to achieve at the present. In order to reduce the storage, we must emphasize examination of a certain portion in the image. To do this we had to design a corresponding window. For example, a window with $N_{\text{top}} = 100$, $N_{\text{bottom}} = 300$, $M_{\text{left}} = 100$, and $M_{\text{right}} = 300$ discards the top 100 rows, the bottom 212 rows, the left most 100 columns, and the right most 212 columns. The schematic circuit structure for this is shown in Figure 10 and the wave form at various points is given in Figure 11. Experiments show that regardless of whether we use a fixed window designed using digital counting circuits or a moving window using a digital comparator or an analog comparator, their control effect is very good.

For a key portion of this paper from each row we selected one image element and picked out a digital image as shown in the photographs. It shows we finally attained the expected aim.

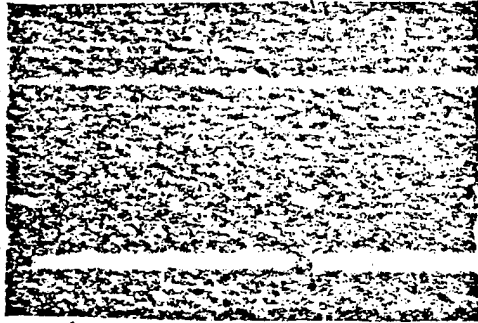

Photograph (1)

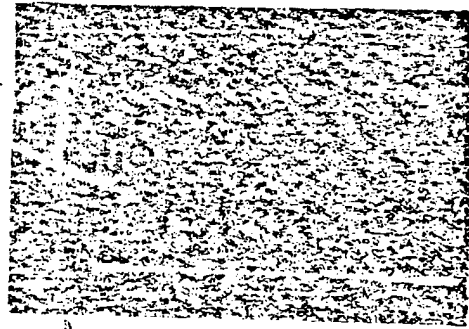

Photograph (2)

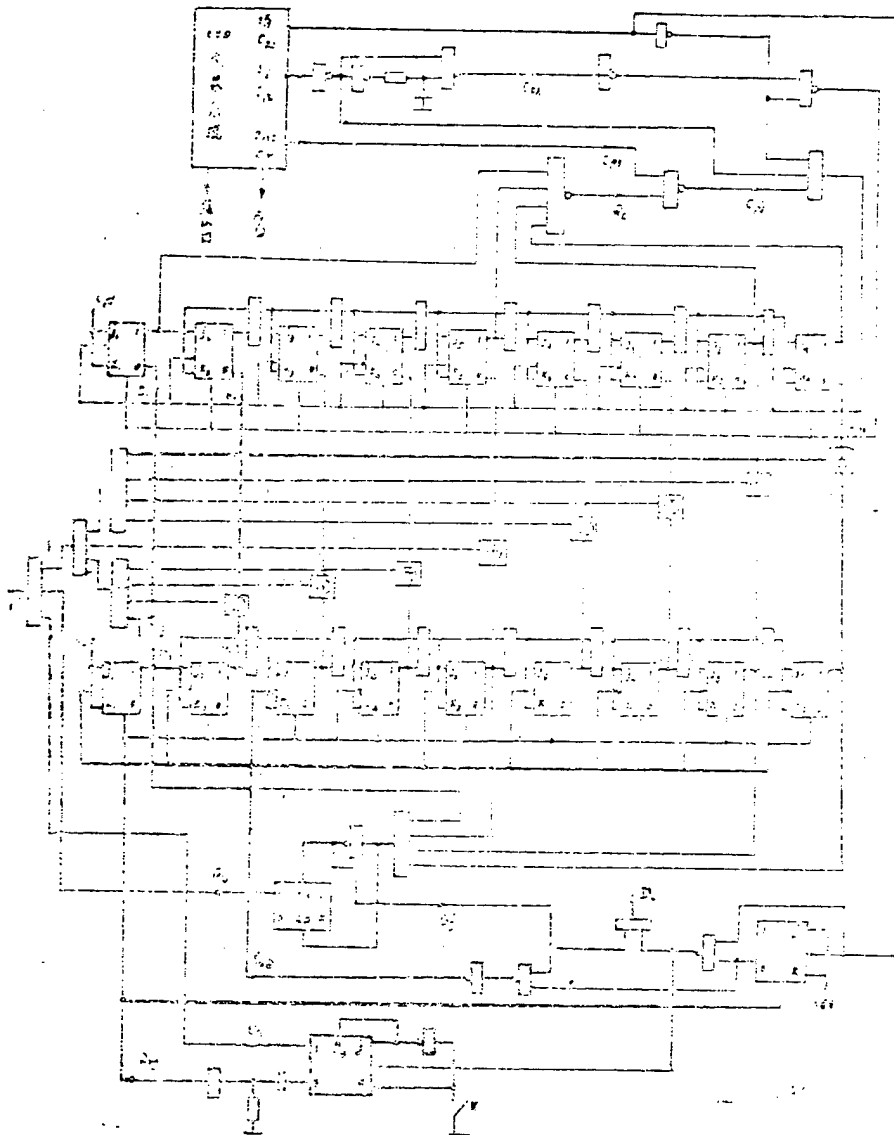

Figure 8. Sampling Circuit for an Area Array CCD Image

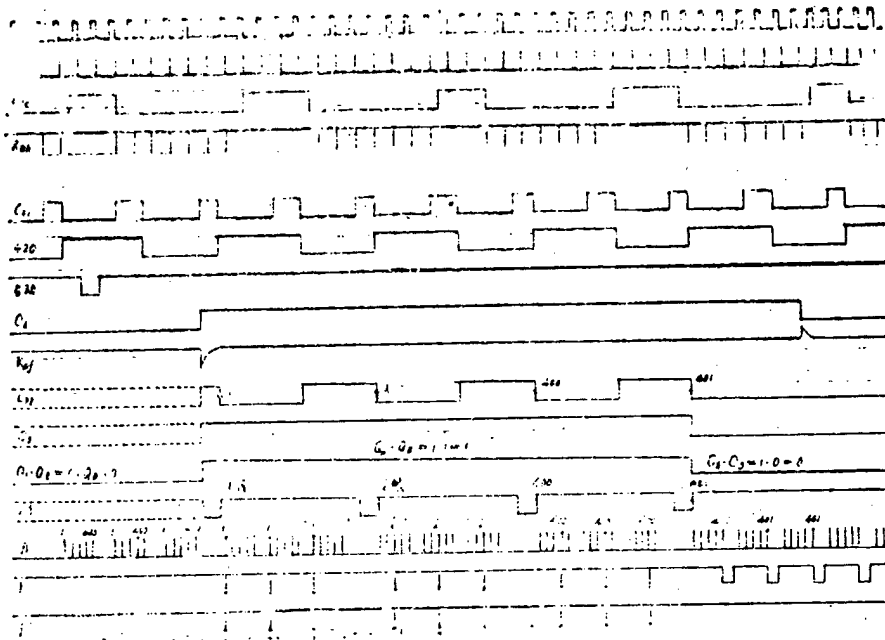

Figure 9. Frame Control and Sampler Output Wave Forms

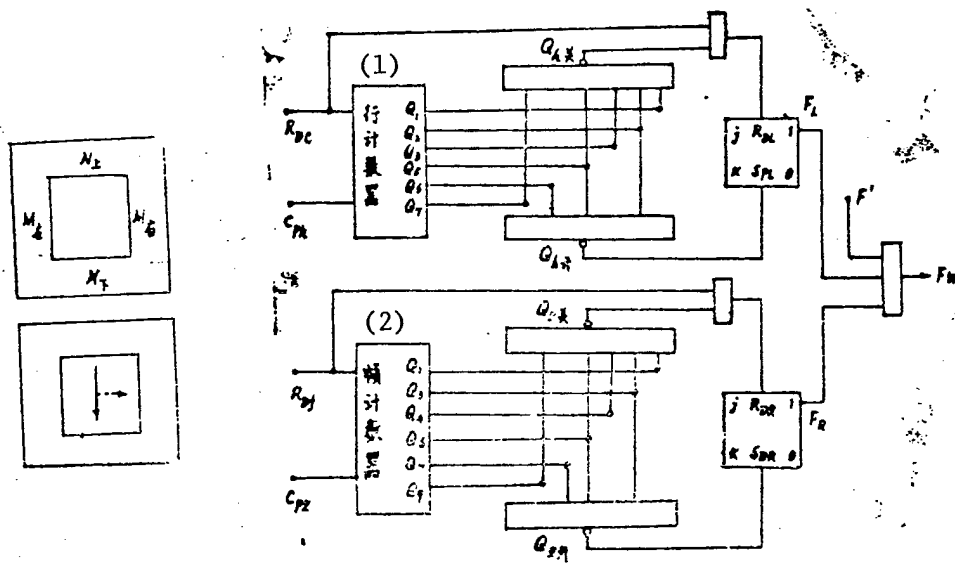

Figure 10. Sampling Window Forming Circuit

Key:

1. Traveling counter
2. Frame counter

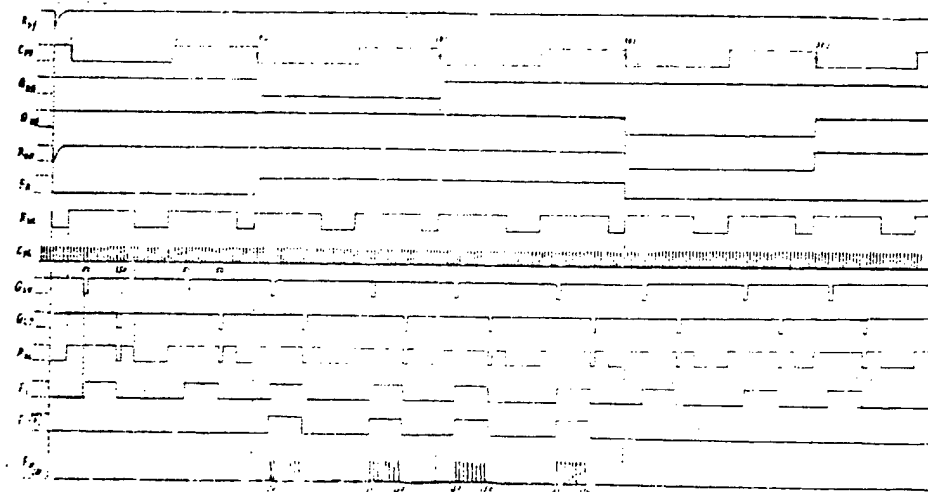

Figure 11. Wave Forms for the Sampling Window Circuit

12966/6091
CSO: 4008/1054

MICROWAVE PROPAGATION IN COUNTRY

Beijing TONGXIN XUEBAO [JOURNAL OF CHINA INSTITUTE OF COMMUNICATIONS] in Chinese Vol 7, No 1, Jan 86 pp 1-9

[Article by Hou Dahan [0186 1129 3352] of the China Research Institute of Radiowave Propagation]

[Text] Abstract: Based on fundamental microwave propagation theory, this paper gives a model of the refraction gradient distribution in China below 100m and computes the variation range of arrival angle in a unit path length for 59 stations distributed in 29 provinces, cities, and autonomous regions with time percentages of 0.1 percent and 99.9 percent corresponding to 50 percent quantities. This paper also provides graphs of the variation of flat earth arrival angles and distance with equivalent earth radii parameters as variables. This information is provided for the design of terrestrial microwave link systems.

I. Introduction

The requirements for digitized microwave relay radio path communications reliability is usually an error rate of 10^{-4} (or 10^{-5}) and the worst monthly breakdown rate does not exceed 0.01 percent. In order to ensure a propagation reliability as high as this, from the point of view of radiowave propagation, we must carry out comprehensive study of all the factors which influence the propagation reliability. However, this is only possible after the fundamental data for each sort of factor has been provided.

The goal of this paper is to deal with microwave line of sight propagation terrestrial radio paths with respect to the fluctuation in the tropospheric index of refraction which leads to variation in the angle of arrival and consequent reduction in radio path propagation reliability. From computed results and tables, we answer the question of under which conditions must this sort of variation be considered and under which can it be ignored in the design of microwave link systems.

Using radio methods it is possible to measure the angle of arrival directly in an actual link. This method, although direct, is not suited to large area reconnaissance. With this method it would also be difficult to encompass the distribution conditions on the scale of the entire country. However,

statistical analysis of long-term historical meteorological data can attain results that are impossible with the direct method. [1] The China Research Institute of Radiowave Propagation used 59 weather stations spread over 29 provinces, cities, and autonomous regions by the National Meteorological Bureau and by processing data from 6 continuous years (1971-1976) of meteorological soundings got the atmospheric refraction gradient below 100m and gave cumulative distribution graphs for each station by year and season (March, April, May as spring, June, July, August as summer, September, October, November as fall, and December, January, and February as winter). [2] This paper used these graphs and data to get the variation of angle of arrival corresponding to the individual median value for each kilometer path length with time percentages of 0.1 percent and 99.9 percent by year and season for the 59 stations and to provide graphs of the relationship of the variation of flat earth arrival angles to distance with equivalent earth radii parameters as variables. These results provide the basis for the design of terrestrial microwave links and have reference value for performance estimates of low altitude microwave radar systems.

II. Computation Formulae

When microwaves are propagated in the lower atmosphere, the changing space-time characteristics of the propagation medium, in addition to leading to changes in the field strength amplitude and polarization direction, also produce bending and other phenomena in the propagation path. In the most general equations for plane wave propagation [3], the equation for the propagation path is

$$(\nabla\varphi)^2 = n^2 \quad (1)$$

Assume that the index of refraction $n(x,y,z)$ in a homogeneous atmosphere varies linearly according to the vector distance r . This agrees with the statistical law for refraction in the atmosphere near the earth (i.e., lower than 1 kilometer). [2] [4] Let

$$\begin{aligned} \nabla n^2 &= -\alpha \\ n^2 &= n_T^2 - \alpha \cdot r \\ &= n_T^2 - (\alpha_x x + \alpha_y y + \alpha_z z) \end{aligned} \quad (2)$$

In the vector relationship shown in Figure 1, n_T is the index of refraction at the transmission point. For any reception point R, the formulae for the relationship of angles r_R and ϕ_R from the z and y axes to n_R and n_T for the reception and transmission points [5] are

$$\cos r_R = -\frac{n_T}{n_R} \cos r_T \quad (3)$$

$$\sin \phi_R = -\frac{n_T \sin r_T}{n_R \sin r_R} \sin \phi_T \quad (4)$$

and the relationship to the geometric straight line distance L with the reception point is

$$L = \frac{4 n_T^2}{a_z} \cos r_T \sin r_T \cos \phi_T - \frac{4 a_x n_T^2}{a_z^2} \cos^2 r_T \quad (5)$$

and

$$\frac{a_z^2}{4 n_T^2 \cos^2 r_T} = \frac{2 n_T^2}{L^2} \frac{a_x}{L} + \left[\left(\frac{2 n_T^2 - a_x L}{L^2} \right)^2 - \frac{a_z^2}{L^2} \right]^{1/2} \quad (6)$$

Because r_T is close to the xy plane and near 90° , the sign in front of the square brackets is taken as positive.

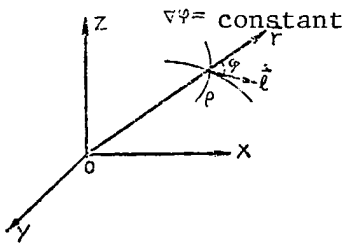

Figure 1. Vector Basic Relationships

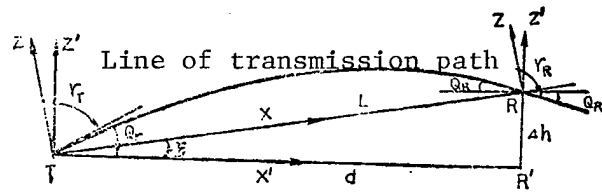

Figure 2. Plane Geometrical Path Relationships

In analyzing the effect of the angle of arrival to actual engineering applications we recognize that the index of refraction is a one-dimensional function of the height, z , above the earth's surface, $n(z)$. In fact, the variation of the angle of arrival within a horizontal range is small and is roughly one-fourth to one-tenth as much as the variation within a vertical range. [5] [6] The low atmosphere refraction gradients dealt with in China, like those in other countries [4], are all characterized by a one-dimensional spatial distribution. For the plane geometric relationship of the radio path shown in Figure 2, we have

$$\begin{aligned} x &= x' \cos \xi + z' \sin \xi, & x' &= x \cos \xi - z \sin \xi \\ z &= -x' \sin \xi + z' \cos \xi, & z' &= z \cos \xi + x \sin \xi \end{aligned}$$

From formula (2)

$$\left. \begin{aligned} -\frac{\partial n^2}{\partial z'} &= a_z \cos \xi + a_x \sin \xi = (a_z d + a_x \Delta h) / L \\ -\frac{\partial n^2}{\partial x'} &= a_x \cos \xi - a_z \sin \xi = (a_x d - a_z \Delta h) / L = 0 \\ -\frac{\partial n^2}{\partial y'} &= 0 \end{aligned} \right\} \quad (7)$$

Therefore

$$\left. \begin{aligned} a_z/a_x &= d/\Delta h \\ L^2 &= (\Delta h)^2 + d^2 \end{aligned} \right\} \quad (8)$$

Using n_T of the transmission point to express the radius of curvature of the line of transmission, R , it can be approximately written as

$$R = \frac{2 n_T^2}{-\partial n^2 / \partial z'} = 2 n_T^2 d / a_x L \quad (9)$$

therefore

$$\left. \begin{aligned} a_z &= \frac{2 n_T^2 d}{LR} = \frac{2 n_T^2}{R} \cos \xi \\ a_x &= \frac{2 n_T^2 \Delta h}{LR} = \frac{2 n_T^2}{R} \sin \xi \\ a_z^2 + a_x^2 &= \left(\frac{2 n_T^2}{R} \right)^2 \end{aligned} \right\} \quad (10)$$

Substituting formulae (8), (9), and (10) in (6) gives

$$\begin{aligned} \frac{1}{\cos^2 r_T} &= \frac{4 R^2}{d^2} \left[1 - \frac{d^2}{4 R^2} - \frac{\Delta h}{R} \right]^{1/2} \\ \cos r_T &= \frac{d}{2 R} \left[1 + \frac{\Delta h}{2 R} + \frac{d^2}{8 R^2} \right] \end{aligned} \quad (11)$$

$$\xi = \Delta h / d - (1/3)(\Delta h)^3 / d^3 \quad (12)$$

From Figure 2 we know $\theta_T - \xi = 90^\circ - r_T$; $\theta_R + \xi = -90^\circ + r_R$ and, considering that when θ_T , θ_R , ξ are all small quantities, we get the elevation angle, θ_T , of the line of transmission at the transmitting point and the incoming wave's angle of arrival, θ_R , at the receiving point

$$\theta_T = \frac{d}{2R} \left(1 + \frac{\Delta h}{2R} + \frac{d^2}{8R^2} \right) + \frac{\Delta h}{d} \left(1 - \frac{(\Delta h)^2}{3d^2} \right) \quad (13)$$

$$\theta_R = \frac{n_T}{n_R} \left[\frac{d}{2R} \left(1 + \frac{\Delta h}{2R} + \frac{d^2}{8R^2} \right) - \frac{\Delta h}{d} \left(1 - \frac{(\Delta h)^2}{3d^2} \right) \right] \quad (14)$$

Statistical results of the 6 continuous years of sounding data from 59 Chinese meteorological stations show that the index of refraction falls with altitude by $e^{-0.1482(1/\text{km})}$. That is, if the altitudes of the receiving and transmitting stations are different by 1 kilometer, the ratio of the indices of refraction at the two stations will be just 1.1597. It is evident then that if only the altitudes of the two stations do not differ by too much then under conditions where the horizontal nonuniformity is not considered n_T and n_R are approximately equal. In the formula the equivalent earth radius, R , is

$$R = K a \quad (15)$$

$$K = (1 + g/157)^{-1} \quad (16)$$

K is the equivalent earth radius coefficient, a is the true earth radius of 6,371 kilometers, g is the index of refraction in N-units expressed in fractions of a kilometer. Further ignoring the higher order terms in formulae (13) and (14), we can write

$$\left. \begin{aligned} \theta &= d/2 k a + \Delta h/d \\ \Delta h &= h_R - h_T \end{aligned} \right\} \quad (17)$$

h_R and h_T are the altitude above sea level of the receiving and transmitting antennas.

III. Computed Results and Application

Make $\theta(0.1 \text{ percent})$, $\theta(50 \text{ percent})$, and $\theta(99.9 \text{ percent})$ respectively represent the cumulative distribution of K values corresponding to the line of transmission angles of arrival (in degrees) when the time percentages are 0.1 percent, 50 percent, and 99.9 percent. Then

$$\left. \begin{aligned} \Delta\theta(0.1\%) &= \theta(0.1\%) - \theta(50\%) \\ \Delta\theta(99.9\%) &= \theta(99.9\%) - \theta(50\%) \end{aligned} \right\} \quad (18)$$

represents the line of transmission angle of arrival variation under conditions of relative average refraction.

$$\Delta\theta(0.2\%) = |\Delta\theta(0.1\%)| + |\Delta\theta(99.9\%)| \quad (19)$$

is the angle of arrival variation range within a time percentage of 0.2 percent.

From formula (17) we know under conditions of a flat earth radio path (Δh can be approximated as zero), θ and d are in direct proportion. Table 1 and Table 2 are computed values of $\Delta\theta(0.1 \text{ percent})$ and $\Delta\theta(99.9 \text{ percent})$ expressed in fractions of a degree per kilometer by year and season for the 59 national stations, based on formula (18), assuming Δh as zero.

From the table we see that when the time percentage is 0.1 percent, the K value for all the stations is less than 1. That is, the g value is uniformly larger than zero and the propagate line of transmission is located in a situation of secondary refraction. At this time taking the equivalent path K_e factor and substituting the K factor [6], we have the following relationship

$$K_e = \begin{cases} K(0.1\%) & d \leq 20 \text{ km} \\ K(0.1\%) + 0.53 \log(d/20) & 20 < d \leq 70 \text{ km} \\ K(0.1\%) + 0.29[1 + \log(d/70)] & d > 70 \text{ km} \end{cases} \quad (20)$$

Figure 3 contains the graphs, based on formula (18), of the relationship between relative angle of arrival, $\Delta\theta_{sub}$ (in degrees) for the situation where the secondary refraction takes the K factor as parameter and the radio path distance, d (in kilometers), taking the K_e factor in place of the K factor, K(50 percent) equal to 4/3, and under conditions where Δh is equal to zero.

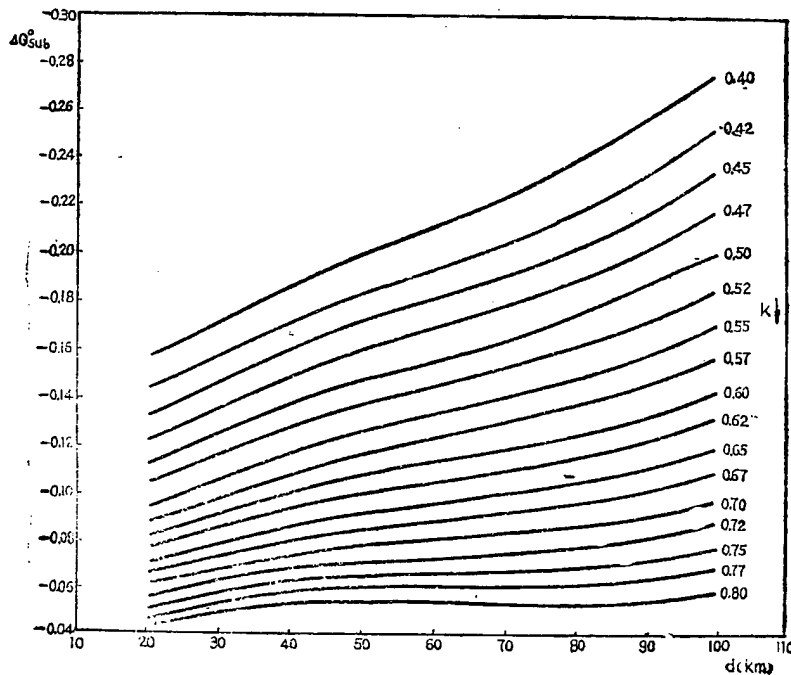

Figure 3. Graphs of the Relationship Between the Relative $\Delta\theta_{sub}$ and d With the Point K Factor as Parameter

When the time percentage is 99.9 percent, the majority of the stations are located in conditions of super refraction. For Δh equal to zero and K(50 percent) equal to 4/3, Figure 4 contains the graphs of the relationship between the relative angle of arrival, $\Delta\theta_{super}$ (in degrees) with the point K factor as parameter and the radio path distance, d (in kilometers). Note that in the situation of super refraction, the K_e factor was not used. Generally it is believed that for situations of super refraction, there will still be some tendency present for an under deviation even if the point K factor is used to calculate. [6]

The Supplement Table gives the height above sea level and the average seasonal and annual K factor median values over the 6 years of the original data.

When designing microwave paths, according to the path's position by consulting Table 1, Table 2, and the Supplementary Table together with Figure 1 and Figure 2, and noting the correction term, $\Delta h/d$, then one can obtain the angular range of the line of transmission angle of arrival and the line of transmission's possible deflection to the antenna's primary axis for any radio path. Consequently, there is the possibility of doing comprehensive analysis of the radio path length, the antenna aperture, the tower rotation angle, and the installation precision.

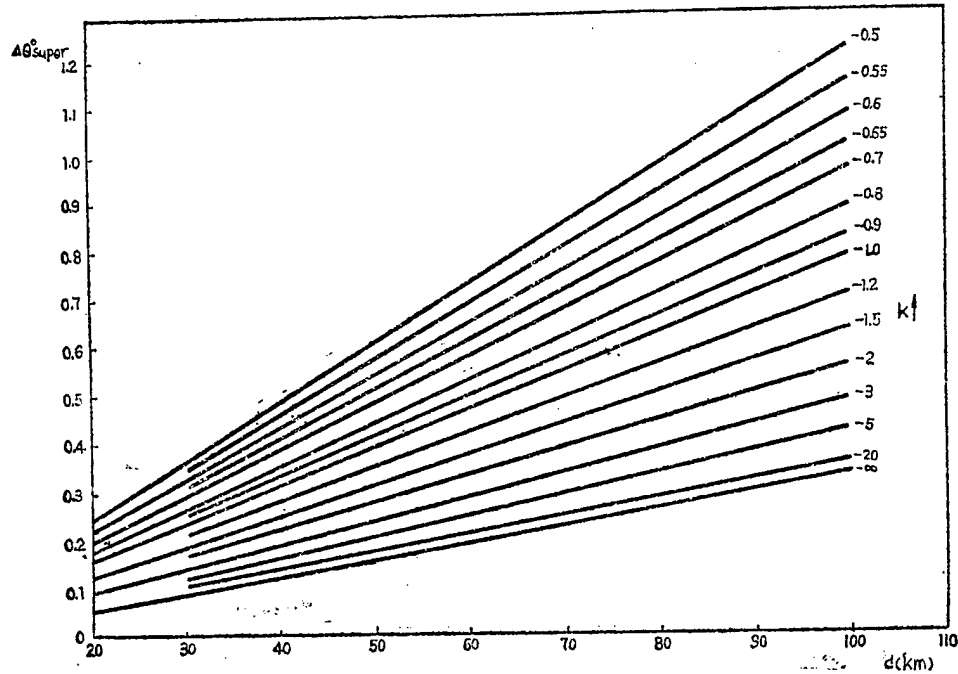

Figure 4. Graphs of the Relationship Between the Relative $\Delta\theta_{\text{super}}$ and d With the Point K Factor as Parameter

Table 1. Annual and Seasonal Angle of Arrival Variation $\Delta\theta(0.1\%) \times 10^{-3}$ Degrees/Kilometers Relative to Individual Median Values

Value Station	Spring		Summer		Fall		Winter		Year		Lat.	Long.
	K	$\Delta\theta$	K	$\Delta\theta$	K	$\Delta\theta$	K	$\Delta\theta$	K	$\Delta\theta$		
Hailar	0.686	-3.091	0.599	-4.386	0.730	-2.782	0.929	-1.891	0.660	-3.575	49	119
Nenjiang	0.940	-1.435	0.660	-3.923	0.683	-3.404	1.154	-1.233	0.683	-3.567	47	124
Harbin	0.737	-2.865	0.595	-4.706	0.773	-2.643	1.146	-0.888	0.618	-4.183	45	126
Changchun	0.844	-1.793	0.474	-6.681	0.592	-4.445	1.138	-0.800	0.485	-6.199	43	125
Yanji	0.650	-3.376	0.586	-4.810	0.734	-2.890	0.849	-2.031	0.602	-4.233	42	129
Shenyang	0.737	-2.951	0.668	-4.012	0.571	-4.754	0.717	-3.065	0.584	-4.655	41	123
Dalian	0.506	-5.415	0.660	-4.122	0.680	-3.491	1.061	-0.714	0.529	-5.351	38	121
Beijing	0.692	-3.608	0.755	-3.462	0.588	-4.784	1.000	-1.383	0.604	-4.582	39	116
Xingtai	0.469	-6.553	0.412	-8.223	0.506	-6.196	0.668	-3.525	0.520	-5.728	37	114
Abgaran Qi	0.793	-1.991	0.616	-4.121	0.882	-1.519	0.924	-1.458	0.662	-3.329	43	116
Huhhot	0.766	-2.493	0.444	-6.892	0.714	-2.807	1.106	-0.657	0.440	-6.757	40	111
Taiyuan	0.853	-2.178	0.581	-4.905	0.692	-3.319	0.918	-1.549	0.581	-4.533	37	112
Jinan	0.724	-2.861	0.577	-4.930	0.680	-3.610	0.755	-2.521	0.599	-4.357	36	117
Qingdao	0.727	-3.121	0.643	-4.183	0.680	-3.548	1.019	-0.949	0.665	-3.641	36	120
Zhengzhou	0.522	-5.578	0.498	-6.339	0.506	-5.943	0.638	-3.723	0.522	-5.133	34	113
Xian	0.622	-3.843	0.471	-6.741	0.505	-4.914	0.900	-1.635	0.534	-5.357	34	108
Yinchuan	0.844	-1.649	0.755	-3.179	0.680	-3.319	0.957	-1.261	0.692	-3.205	38	106
Laodongmiao	0.826	-1.864	0.545	-4.557	0.773	-2.354	1.040	-1.144	0.561	-4.522		
Jinquan	0.831	-1.973	0.621	-4.465	0.724	-2.974	1.054	-0.857	0.623	-3.954*	39	98*
Lanzhou	0.929	-1.232	0.809	-2.121	0.805	-2.006	0.887	-1.490	0.822	-1.891	36	103

Table 1 (Continued)

Value Station	Spring		Summer		Fall		Winter		Year		Lat.	Long.
	K	$\Delta\theta$	K	$\Delta\theta$	K	$\Delta\theta$	K	$\Delta\theta$	K	$\Delta\theta$		
Xining	0.867	-1.422	0.849	-1.688	0.826	-1.744	1.047	-0.657	0.849	-1.632	36	101
Golmud	0.994	-1.069	0.741	-2.316	0.813	-1.893	0.863	-1.602	0.781	-2.093	36	94
Darla	0.957	-0.603	0.940	-0.977	0.994	-0.658	1.098	-0.171	0.935	-0.972	33	99
Altay	0.785	-2.235	0.668	-3.012	0.744	-2.550	1.047	-0.512	0.683	-3.203	47	88
Quqek	0.633	-3.610	0.540	-4.776	0.797	-2.033	1.061	-0.944	0.534	-4.928	46	82
Urumqi	0.686	-3.314	0.651	-3.414	0.797	-2.062	1.129	-0.856	0.668	-3.208	43	87
Kumul	0.809	-2.065	0.480	-5.988	0.689	-3.262	0.950	-1.373	0.474	-6.251	42	93
Kaxgar	0.801	-2.120	0.680	-3.175	0.755	-2.462	1.000	-0.888	0.698	-2.919	39	75
Qarkilik	0.683	-3.004	0.421	-7.188	0.737	-2.501	1.047	-0.831	0.416	-7.317	39	88
Hotan	0.858	-1.747	0.695	-3.120	0.908	-1.236	0.751	-2.408	0.717	-2.808*	37	79*
Shanghai	0.621	-4.292	0.797	-2.999	0.720	-3.200	0.609	-3.975	0.606	-4.385	31	121
Xuzhou	0.701	-3.325	0.611	-4.610	0.631	-4.091	0.777	-2.493	0.616	-4.236	34	117
Nanjing	0.734	-3.044	0.822	-2.863	0.631	-4.149	0.717	-2.949	0.643	-3.998	32	118
Fuyang [AH]	0.660	-3.807	0.565	-5.297	0.581	-4.876	0.957	-1.434	0.623	-4.269	32	115
Quxian [ZJ]	0.571	-4.985	0.563	-5.439	0.491	-6.238	0.701	-3.092	0.584	-4.730	28	118
Dachendao	0.563	-4.716	0.730	-3.353	0.877	-2.150	0.606	-3.870	0.559	-4.927	28	121
Nanchang	0.773	-2.897	0.789	-3.008	0.692	-3.608	0.853	-2.058	0.720	-3.355	28	115
Ganzhou	0.822	-2.033	0.571	-5.123	0.781	-2.722	0.849	-1.859	0.599	-4.443	25	114
Fuzhou [FJ]	1.000	-1.432	0.918	-2.178	0.877	-2.034	0.822	-1.868	0.872	-2.062	26	119
Taoyuan	0.748	-3.148	0.809	-2.892	0.714	-3.463	0.770	-2.747	0.730	-3.296	28	111
Donggang	0.641	-4.296	0.707	-3.898	0.724	-3.491	0.695	-3.636	0.649	-4.237		
Dongsha	0.717	-3.442	0.840	-2.987	0.797	-2.975	1.013	-1.632	0.773	-3.212	20	116
Hankou	0.840	-2.518	0.741	-3.520	0.744	-3.267	0.963	-1.605	0.773	-3.011	30	114
Enshi	0.918	-1.822	0.818	-2.919	0.969	-1.864	0.952	-1.315	0.801	-2.664	30	109
Changsha	0.797	-2.692	0.527	-5.922	0.789	-2.750	0.813	-2.266	0.522	-5.565	28	113
Shantou	0.765	-2.838	0.534	-5.592	0.858	-2.350	0.793	-2.464	0.555	-5.107	23	116
Guangzhou	0.813	-2.581	0.698	-3.723	0.689	-3.567	0.710	-3.097	0.698	-2.005	23	113
Haikou	0.686	-3.664	0.590	-4.930	0.609	-4.367	0.727	-3.092	0.592	-4.705	20	110
Xisha	0.840	-2.614	0.872	-2.551	0.683	-3.849	0.946	-1.832	0.744	-3.287	16	112
Guilin	0.724	-3.061	0.897	-2.236	0.701	-3.321	0.781	-2.341	0.720	-3.124	25	110
Nanning	0.766	-2.806	0.530	-5.708	0.557	-5.354	0.781	-2.599	0.543	-5.361	22	108
Guiyang	0.683	-3.146	0.755	-2.834	0.720	-2.837	0.717	-2.490	0.692	-3.061	26	106
Tengchong	0.853	-1.577	0.785	-2.406	0.813	-2.067	0.867	-1.572	0.781	-2.149	25	98
Kunming	0.538	-5.098	0.877	-1.778	0.646	-3.323	0.755	-2.090	0.532	-4.814	25	102
Chengdu	0.641	-3.922	0.654	-4.156	0.805	-2.572	0.853	-1.863	0.646	-3.896	30	104
Chongqing	1.006	-1.233	1.047	-1.345	0.929	-1.719	1.061	-0.800	0.926	-1.633	29	106
Xichang	0.631	-3.462	0.781	-2.415	0.822	-1.862	0.902	-1.232	0.789	-2.062	27	102
Nagqu	0.766	-2.528	0.793	-1.798	0.892	-1.171	1.000	0.737	0.781	-1.892	31	92
Lhasa	0.818	-1.715	0.835	-1.663	0.758	-2.151	0.946	-1.004	0.773	-2.068	29	91

Table 2. Annual and Seasonal Angle of Arrival Variation $\Delta\theta(99.9\%) \times 10^{-3}$
Degrees/Kilometers Relative to Individual Median Values

Value Station	Spring		Summer		Fall		Winter		Year	
	K	$\Delta\theta$	K	$\Delta\theta$	K	$\Delta\theta$	K	$\Delta\theta$	K	$\Delta\theta$
Hailar	4.618	2.491	-9.235	3.610	22.429	3.178	3.204	1.547	∞	3.238
Nenjiang	-7.136	3.982	-0.643	9.882	14.273	2.866	19.625	2.436	-5.607	3.817
Harbin	31.400	3.095	-2.907	4.439	-22.429	2.975	5.414	2.206	-7.850	3.569
Changchun	-7.136	3.925	-0.963	7.479	-1.784	5.673	2.661	1.462	-5.607	3.898
Yanji	14.273	3.124	-2.343	4.870	4.243	2.178	2.574	1.519	-12.077	3.610
Shenyang	∞	3.125	-1.707	5.416	-4.361	4.154	2.275	1.231	-3.340	4.384
Dalian	-3.651	4.771	-1.764	5.243	-5.815	3.896	3.140	2.093	-5.233	4.011
Beijing	-0.844	8.221	-0.781	8.151	-1.342	6.217	3.140	1.683	-1.083	6.918
Xingtai	-1.298	6.502	-0.599	10.202	-0.680	9.307	-4.618	4.182	-0.704	9.312
Abgaran Qi	2.661	1.891	-15.700	3.467	4.906	2.664	2.211	1.376	39.250	3.350
Huhhot	2.962	4.898	-1.090	7.354	6.542	2.802	2.532	1.634	78.500	3.408
Taiyuan	-1.524	5.947	-0.425	12.319	-1.524	6.132	3.271	1.977	-0.636	10.280
Jinan	-5.815	4.126	-2.056	5.042	-19.625	3.238	3.271	2.061	-6.542	3.840
Qingdao	-12.077	3.438	-1.040	7.103	-15.700	3.353	3.140	2.033	-3.340	4.470
Zhengzhou	-1.000	7.537	-1.054	6.960	-1.195	6.733	6.542	2.636	-1.208	6.732
Xian	-0.668	9.488	-0.476	12.250	-1.026	7.421	12.077	2.980	-0.631	10.194
Yinchuan	-6.826	4.098	-0.631	10.906	-2.804	4.899	2.161	1.377	-1.266	6.348
Laodongmiao	78.500	3.524	-31.400	3.898	3.568	2.204	2.707	1.519	9.813	3.037
Jinquan	-2.309	4.614	-0.437	12.990	-2.962	4.756	2.181	1.348	-0.599	10.773
Lanzhou	3.829	2.435	-1.784	5.360	-3.482	4.369	2.151	1.490	-19.625	3.810
Xining	9.813	3.296	-0.840	8.954	13.083	2.434	1.963	1.348	-3.829	4.841
Golmud	2.532	1.920	2.574	2.007	3.535	2.378	2.211	1.576	2.907	2.115
Darla	1.454	0.895	2.066	1.631	1.495	0.858	1.389	0.627	2.068	1.661
Altay	4.361	2.464	-19.625	3.754	-6.542	4.182	17.444	3.525	9.813	2.924
Quqek	8.263	2.951	-0.758	9.486	-4.486	4.613	3.829	2.120	-1.576	6.360
Urumqi	4.618	2.438	-6.280	3.211	3.925	2.435	2.243	1.405	8.263	3.079
Kumul	-4.361	4.526	-0.547	11.585	-1.938	5.497	2.754	1.919	-0.781	9.007
Kaxgar	-1.892	5.772	-0.744	9.484	-2.181	5.557	-6.280	2.294	-1.956	7.726
Qarkilik	-2.907	5.128	-0.902	7.481	-2.804	4.842	3.140	2.033	-1.437	6.561
Hotan	-1.256	7.076	-1.108	7.422	-1.653	6.131	4.243	2.521	-1.493	6.474
Shanghai	-15.700	3.238	-1.026	7.019	-8.722	3.564	3.019	1.920	-4.132	4.125
Xuzhou	-19.467	3.523	-1.145	6.676	-4.361	4.068	6.542	2.607	-2.093	5.215
Nanjing	-13.083	3.353	-1.440	5.732	-3.340	4.324	2.754	1.691	-2.453	4.831
Fuyang	-1.189	6.821	-0.522	11.281	-1.098	6.961	-4.361	4.297	-0.737	9.054
Quxian	-1.061	7.131	-1.236	6.189	-2.275	4.900	6.826	2.665	-1.208	6.646
Dachendao	-3.294	4.670	-1.688	5.473	-2.574	4.726	52.333	3.467	-2.707	4.785
Nanchang	-1.725	5.528	-0.528	11.195	-3.204	4.296	5.815	2.442	-1.402	6.100
Ganzhou	-3.204	5.270	-3.829	3.929	-3.340	4.384	2.532	1.661	-4.026	4.183
Fuzhou	5.414	2.235	-17.444	2.979	7.476	2.494	1.963	1.313	17.444	2.838
Taoyuan	-1.331	6.236	-0.946	7.453	-2.013	5.070	-2.039	5.301	-1.007	6.531
Donggang	-2.707	4.383	-2.013	4.699	-0.877	7.844	-1.061	7.075	-1.227	6.359
Dongsha	-1.847	5.014	-0.777	8.166	-19.625	2.897	9.235	2.329	-2.243	4.612
Hankou	-1.892	5.213	-1.365	5.845	-2.181	4.840	5.065	2.177	-2.066	4.985
Enshi	-1.353	6.247	-1.098	6.675	-1.688	5.443	7.136	2.789	-1.293	6.416
Changsha	-1.784	5.472	-0.654	9.481	-2.039	5.157	3.140	1.843	-1.154	6.849

Table 2 (Continued)

Value Station	Spring		Summer		Fall		Winter		Year	
	K	$\Delta\theta$	K	$\Delta\theta$	K	$\Delta\theta$	K	$\Delta\theta$	K	$\Delta\theta$
Shantou	4.132	1.948	22.429	2.520	78.500	2.835	3.651	1.976	11.214	2.596
Guangzhou	-2.574	4.698	-2.574	4.468	-2.243	4.966	31.400	3.095	-3.340	4.344
Haikou	13.083	2.548	-3.829	3.868	14.273	2.700	5.065	2.700	∞	2.208
Xisha	-4.906	3.638	19.625	2.378	4.758	1.891	2.379	1.891	5.065	1.032
Guilin	-3.340	4.498	-2.932	4.297	-2.661	4.786	4.132	4.786	-3.078	2.350
Nanning	-8.263	3.611	-1.744	5.357	-1.892	5.098	-1.670	5.098	-2.093	5.874
Guiyang	6.280	2.723	8.233	2.579	-2.907	1.863	2.122	1.863	4.906	1.662
Tengchong	2.617	1.977	2.661	1.634	3.078	2.004	2.962	2.004	2.907	2.348
Kunming	10.457	2.832	-9.813	3.810	17.444	3.321	4.361	3.381	52.333	2.830
Chengdu	-2.907	4.643	-0.660	9.536	-1.938	5.336	4.618	5.336	-0.992	2.436
Chongqing	3.271	1.863	-78.500	3.008	3.078	1.662	2.181	1.662	7.250	1.377
Xichang	-11.214	4.067	-10.467	3.774	39.250	3.494	3.568	3.494	12.077	2.473
Nagqu	1.688	0.678	2.804	2.270	2.275	1.894	1.585	1.894	2.151	0.925
Lhasa	1.826	1.320	-1.635	6.473	3.204	2.379	1.707	2.379	4.361	2.020

Supplement Table. Seasonal and Annual Median Values of K Factor

K (50%) Station	Season Sea level elevation (m)	Spring	Summer	Fall	Winter	Year
		(Mar-May)	(Jun-Aug)	(Sep-Nov)	(Dec-Feb)	
Hailar	612.9	1.298	1.440	1.331	1.524	1.389
Nenjiang	222.3	1.342	1.555	1.414	1.688	1.492
Harbin	171.7	1.389	1.555	1.416	1.481	1.453
Changchun	236.8	1.365	1.602	1.427	1.427	1.453
Yanji	176.8	1.308	1.570	1.389	1.377	1.389
Shenyang	41.6	1.427	1.653	1.440	1.402	1.481
Dalian	15.6	1.308	1.670	1.440	1.276	1.427
Beijing	31.2	1.555	1.805	1.570	1.414	1.570
Xingtai	76.8	1.481	1.670	1.670	1.402	1.539
Abgaran Qi	985.5	1.256	1.414	1.256	1.319	1.298
Huhhot	1063.3	1.331	1.389	1.288	1.313	1.298
Taiyuan	777.9	1.453	1.586	1.414	1.342	1.402
Jinan	53.0	1.342	1.570	1.495	1.319	1.427
Qingdao	82.2	1.467	1.619	1.467	1.298	1.440
Zhengzhou	110.4	1.481	1.670	1.510	1.353	1.492
Xian	396.9	1.524	1.602	1.481	1.342	1.467
Yinchuan	1111.5	1.308	1.619	1.365	1.308	1.365
Laodongmiao	935.5	1.256	1.217	1.298	1.414	1.287
Jinquan	1477.2	1.308	1.619	1.389	1.319	1.377
Lanzhou	1517.2	1.246	1.308	1.256	1.256	1.256
Xining	2296.2	1.198	1.246	1.217	1.236	1.227
Golmud	2806.1	1.217	1.198	1.236	1.246	1.227
Darla	3967.5	1.154	1.181	1.163	1.146	1.172
Altay	735.1	1.287	1.276	1.287	1.189	1.330
Qukek	548.0	1.287	1.266	1.246	1.365	1.287
Urumqi	653.5	1.256	1.287	1.256	1.319	1.276

Supplement Table (Continued)

K (50%) Station	Season Sea level elevation (m)	Spring (Mar-May)	Summer (Jun-Aug)	Fall (Sep-Nov)	Winter (Dec-Feb)	Year
Kumul	737.9	1.287	1.330	1.377	1.342	1.383
Kaxgar	1288.7	1.287	1.308	1.287	1.246	1.276
Qarkilik	888.3	1.256	1.287	1.387	1.298	1.287
Hotan	1374.6	1.287	1.342	1.319	1.256	1.298
Shanghai	4.5	1.524	1.707	1.467	1.319	1.481
Xuzhou	34.0	1.454	1.635	1.481	1.365	1.467
Nanjing	8.9	1.495	1.725	1.510	1.353	1.501
Fuyang	31.2	1.495	1.688	1.570	1.377	1.524
Quxian	66.1	1.555	1.764	1.539	1.353	1.539
Dachendao	204.1	1.377	1.602	1.510	1.266	1.440
Nanchang	46.7	1.539	1.805	1.555	1.399	1.555
Ganzhou	123.8	1.467	1.635	1.481	1.308	1.467
Fuzhou	84.0	1.467	1.653	1.453	1.298	1.453
Taoyuan	48.0	1.570	1.688	1.583	1.453	1.570
Donggang	8.0	1.653	1.826	1.653	1.586	1.670
Dongsha	6.0	1.744	1.892	1.686	1.602	1.725
Hankou	23.3	1.586	1.764	1.619	1.467	1.602
Enshi	437.2	1.539	1.744	1.619	1.319	1.524
Changsha	44.5	1.524	1.725	1.524	1.377	1.524
Shantou	4.0	1.481	1.635	1.555	1.402	1.501
Guangzhou	6.3	1.524	1.635	1.510	1.389	1.504
Haikou	14.1	1.555	1.670	1.499	1.453	1.555
Xisha	4.0	1.653	1.725	1.582	1.539	1.619
Guilin	169.7	1.427	1.619	1.453	1.308	1.440
Nanning	75.0	1.467	1.610	1.653	1.414	1.539
Guiyang	1150.0	1.305	1.440	1.319	1.184	1.308
Tengchong	1647.9	1.217	1.353	1.292	1.163	1.246
Kunming	1891.4	1.236	1.342	1.236	1.163	1.236
Chengdu	505.0	1.453	1.653	1.492	1.319	1.467
Chongqing	351.1	1.389	1.524	1.440	1.308	1.414
Xichang	1598.7	1.227	1.303	1.246	1.192	1.236
Nagqu	4507.0	1.154	1.163	1.163	1.198	1.163
Lhasa	3658.0	1.189	1.298	1.189	1.199	1.199

REFERENCES

1. Akiyama, T., "Variability of the Angle of Arrival of Microwaves," DENKI TSUSHIN GAKKAI ZASSHI [JOURNAL OF THE TELECOMMUNICATIONS SOCIETY] in Japanese, Vol 50, Feb 1967, p 229.
2. Yang Guangcai [2254 1639 2088], Wu Xide [0702 1585 1795], Dong Zhenling [5516 6297 3781], and Lin Xiuwan [2651 4423 1238], "Zhongguo Dikong Zheshelu Tuji" [Low Atmosphere Refraction Rate Tables for China], China Research Institute of Radiowave Propagation.

3. Born, M. and E. Wolf, "Principles of Optics," 6th Ed., 1980, p 112.
4. Segal, B. and R.E. Barrington, "Tropospheric Refractivity Atlas for Canada," Ottawa, December 1977.
5. Shkarotcky, I.P. and S.B. Nickerson, "Depolarization Due To Multiple Propagation in Radio Relay Systems," NPB-124-1. CRC. Ottawa, Canada, 1978.
6. CCIR, Report, 338-4, 1983.

12966/6091

CSO: 4008/1064

PROGRAMMABLE A/D AMPLIFIER INTERFACE FOR S-100 BUS

Tianjin TIANJIN KEJI XIAOXI [TIANJIN SCIENCE & TECHNOLOGY NEWS] in Chinese
No 4, 15 Apr 86 p 10

[By the Thermal Energy Institute of Tianjin University: "Intelligent Interface Board for Microcomputer Broad Measuring Ranges"]

[Text] The microcomputer broad measuring range intelligent interface board developed by the Thermal Energy Institute of Tianjin University for use in various processes for automatic testing passed its technical evaluation by state science and technology organizations in November 1985. This interface is a new model interface that was developed in light of the weak link in microcomputer applications at present in China where existing analog interface costs are high and inconvenient to use. Having the features of a broad dynamic range, high precision, convenient usage, and low cost, use of this interface circuit allows very convenient construction of multipoint automatic testing systems.

I. Primary Features

The broad measuring range intelligent interface operates in an automatic test process mode, and without increasing costs has expanded the dynamic range of the interface board. This interface uses an 8-bit D/A convertor to make a precision programmable amplifier, which allows the amplification multiplier of the amplifier to change within 255 levels. The control precision of the microcomputer can program the amplifier to keep the interface board operating at the optimum measurement state, that is, where the effective output values for the A/D convertor are between 200 and 255, and where the numeric value multiplier of the A/D convertor input into the computer can precisely program the amplification multiplier of the amplifier, that is, it can reach actual measured values. In this way, the 8-bit wide A/D convertor implements the automatic A/D conversion in a 16-bit dynamic range, and ensures that the conversion error will be less than 1 percent of the measured value. By consequently lowering the costs, the performance to cost ratio is markedly improved. The optimized control software for this interface board allows the interface board to be adjusted in a shorter time. To alleviate difficulties with a single-board microcomputer having to be programmed in machine language, this interface board is also provided with a library of common floating point calculation subroutines.

II. Primary Technical Specifications

1. Analog/digital conversion dynamic range: 6.5×10^4
2. Conversion precision: error $< 1\%$ of measured value
3. Conversion time:
 - when measured value transformation range is great,
 < 400 microseconds
 - when measured value transformation range is small,
 $= 100$ microseconds
4. Number of analog/digital conversion circuits: 24 channels
5. Number of digital/analog conversion circuits: 2 channels
6. Applicable computers: TP801 single-board microcomputer
Cromemco microcomputer systems
7. Bus type: S-100 bus
8. Subroutine library: (uses EPROM)

subroutines for interface board automatic test and measurement
subroutines to display A/D conversion values
subroutines for zero point correction and to satisfy measurement
range corrections
addition, subtraction, multiplication, and division subroutines
for floating point calculations

12586

CSO: 4008/1074

PROGRAM CONTROLLED TELEPHONE SOFTWARE SYSTEM

Tianjin TIANJIN KEJI XIAOXI [TIANJIN SCIENCE & TECHNOLOGY NEWS] in Chinese
No 4, 15 Apr 86 pp 10-11

[Article by Gu Manhong [7357 3341 3163], Tianjin Municipal Computer Center:
"Statistical Software for Programmed Telephone Measured Charges"]

[Text] The first 10,000 set program controlled telephone exchange (31 urban telephone exchanges) and a 1,000 line long distance program controlled exchange produced by the Japanese NEC company and imported by the Tianjin Municipal Office of Posts and Telecommunications have been major importation projects for Tianjin. The Tianjin Municipal Computing Center has taken responsibility for the complete configuration of the measured charges portion of this equipment, and regarding hardware, the existing equipment provided by the Computing Center serves the Office of Posts and Telecommunications Management. Measured charges statistical software was to be developed by the Computing Center. This software officially went into service in July 1985, and after one-half year of actual operations, it passed its municipal level evaluation in December 1985.

I. Operational Mode of the Software System

Measured charges statistical software is divided into the two completely independent parts that are the intra-city program controlled telephone measured charges statistical software (or "urban telephone software" for short) and long distance program controlled telephone measured charges statistical software (or "long distance software" for short), both of which run on the municipal Computing Center's M-160 computer. Operation of the urban telephone software is done through prompts interactively from the computer terminals, which may be manually interrupted by the operations personnel since the entire process is visible at a glance. CPU time to process a tape having one month's measured charges is about just over 1 minute, and after on-line operations, the entire report can be had in about one-half hour. The payments received report in this alone is more than 1,000 times more efficient than doing it by hand. Operation of the long distance software is by batch mode from the computer terminals, and only two parameters need be changed for the entire operation: one is the name of the measured charges tape for that month as provided by the long distance office, and the other is the data space determined in accordance with the volumes for that

month's calls. Both sets of software may be run by only one person, and they are extremely easy.

II. The Software System

A. The urban telephone software.

The urban telephone software is composed of the subscriber file maintenance file, the computer modules, the Chinese-character report output module, and the subscriber file post-processing module.

1. The subscriber file maintenance module: this is used to maintain the subscriber file, and has functions for adding, revising, and deleting subscriber file records.

2. The computer modules: this module enters the number of completed calls into the subscriber file from the tape, and it also calculates the frequency of calls for the subscriber from the previous month's billing period through this month's billing period.

3. The Chinese-character report output module: this module outputs seven types of Chinese character reports for bank measured charge statements.

4. The subscriber file post-processing module: this module completely clears the financial entries for the particular month in a subscriber file that has been processed, and it classifies these according to telephone number in preparation for the next month.

B. The long distance software.

The long distance software is composed of a main file maintenance module, a data module for generating reports, and a module for generating reports.

1. The main file maintenance module:

The functions for this module are the same as for the subscriber file maintenance module in the urban telephone software.

2. The data module for generating reports.

This module is composed of five submodules: namely, the phone bill recognition submodule, the revise phone charges submodule, the main calling subscriber processing submodule, the called subscriber processing submodule, and the coupling module.

This module takes as its input data the primary file for that month as generated after maintenance and the measured charges tape obtained after data processing.

3. The report generation module:

After processing of report data, this module also outputs seven kinds of statistical reports on call charges and call service volumes as required by the long distance telephone office, as for example for charged accounts.

Successful development of this software has saved the state from having to expend foreign currency. It was originally planned to import a computer that would have cost \$190,000. Currently, relevant personnel are preparing to disseminate the urban telephone software abroad, after porting to microcomputers.

12586

CSO: 4008/1074

COMPUTER CONTROL FOR POST-ROLLING HEAT TREATMENT

Tianjin TIANJIN KEJI XIAOXI [TIANJIN SCIENCE & TECHNOLOGY NEWS] in Chinese
No 4, 15 Apr 86 pp 11-12

[Article by the Tianjin Institute of Electric Drive Design: "A Microcomputer Control System for Post-Rolling Residual Heat Treatment"]

[Text] A post-rolling residual heat treatment microcomputer self-adapting system does on-line real time analysis of multiple parameters in the post-rolling residual heat treatment of threaded steel reinforcements, integrates and uses the principle of self-adaptation, and adjusts the flow and pressure of incoming water in accordance with parameters such as differing types of steel, carbon content, and specifications, as well as the temperature of the rolled steel at the end of the rolling process, the temperature of the cooling water, and the auto-tempering temperature to attain optimum control of the post-rolling heat treatment technical process, consequently reaching the goal of improving product quality.

The Tianjin Municipal Steel Rolling Mill No 2 Small-scale Rolled Steel Products Workshop set up post-rolling residual heat treatment techniques and equipment in 1983, and they have achieved definite results in improving the performance of steel products and in improving product quality. But because the residual heat treatment process is a non-linear process with many parameters and change coefficients, as changes regularly occur in the various technical parameters during the rolling process and in working conditions, the configuration of the residual heat treatment is not automatically controlled when done manually, and it is difficult to ensure the quality of rolled steel products so processed, and even harder to ensure achievement of export specifications for rolled steel products. In addition to this, because on-site water pressure is great and the water temperature is high, manual operations are not only labor intensive but also unsafe. To guarantee and improve product quality and to improve work conditions, with the support and concern of the Tianjin Municipal Economics Commission and the Tianjin Municipal Metallurgy Office, the Tianjin Municipal Steel Rolling Mill No 2 and the Tianjin Institute of Electric Drive Design of the Ministry of Machine Building Industries jointly developed a microcomputer control system for post-rolling residual heat treatment.

The microcomputer control system for post-rolling residual heat treatment has the following several features:

1. It has on-line calculated determination of the process model for post-rolling residual heat treatment. In accordance with the type of steel, model, specifications, carbon content, and standard rolling termination temperature of the processed rolled steel product, the computer calculates the autotempering temperature and the allowed passive range with its goal being the calculation values that will ensure a standard yield strength for rolled steel products of os, storing the tempering temperature goal value in memory. At the same time, the computer checks the cooling water intake temperature and calculates the amount of flow needed at the standard rolling termination temperature to reach the standard autotempering temperature, and also stores this in memory.

The computer calculates and sets the initial flow quantities in accordance with the value characteristics, then reports and prints the initial flow values.

Model calculation time $T < 50$ ms
Calculation accuracy $S < 0.1\%$

2. It searches for, reports on, and prints out the post-rolling residual heat treatment technical parameters.

The computer does a revolving test, display, and print out of the reinforcing bar rolling termination temperature in the post-rolling residual heat treatment and some 20 technical parameters such as reinforcing bar autotempering temperature, cooling flows in each channel, pressures, cooling water inlet temperature, and cooling water outlet temperature.

3. It has closed-loop control of the autotempering temperature in the post-rolling residual heat treatment process. The microcomputer control system adjusts the flow of cooling water based on factors like actual reinforcing bar rolling termination temperature and the temperature of the cooling water inlet, by which it implements forward feed automatic control of the autotempering temperature.

Based on deviations between the measured reinforcing bar autotempering temperature and the model computed reinforcing bar autotempering temperature, the system adjusts the cooling water flows to effect forward feed automatic control of the autotempering temperature.

4. It has auto adaptation correction for the model parameters. This system uses a built-up mnemonics model parameter auto adapting correction by a recurring least squares method, thereby reaching its goal of improving model accuracy and expanding the scope of application for the model.

This installation completed full scale packaging and debugging tests at the end of October 1984, and was placed in feedback small loop operation. In February 1985 it once again undertook feedforward and auto adaptation operations, in which it accomplished all tasking in the original

specifications. Product quality of reinforcing bars was stabilized through use of the computerized control of rolling, and has attained the British BS-4449-78 revised standard of 1983.

Since this closed loop went into operation, it has been used for the collection, display, and print out of more than 20 items of data involving all stages of cooling water pressures, flows, temperatures, rolled item rolling termination temperatures, autotempering temperatures, and root parameters.

After production inspection and verification, and with stability, reliability, and flexibility of control after closed-loop operation, this system can do parametric auto-adaptation correction of numerical models in the technical process, as well as multiple parameter control of the reinforcing bar performance. It displays and prints out averages accurately, and there have never been erroneous actions or malfunctions during operations.

12586

CSO: 4008/1074

COMPUTERIZED CONTROL FOR LIQUID GAS SYSTEM DESCRIBED

Tianjin TIANJIN KEJI XIAOXI [TIANJIN SCIENCE & TECHNOLOGY NEWS] in Chinese
No 4, 15 Apr 86 p 12

[Article by Chen Yongyou [7115 3057 0327], Tianjin Municipal Coal Gas Company:
"Microcomputer Liquefied-gas Bottling Safety Monitoring and Scheduling
Management On-Line System"]

[Text] The Tianjin Municipal Coal Gas Company is the key unit in the city for combustibles and explosives, and with the great development of the Tianjin city coal gas undertaking, and especially after the resolution by the Tianjin city government proposing gas service to the entire civilian sector within 3 years, this company has become more and more concerned about safe operations. It has decided to use the advanced technologies of microcomputers to do safe schedule monitoring in the liquefied gas system and in the natural gas transmission and distribution system to ensure safe operations and reliable provision of gas. In 1984, this company began to establish the company--Dagang liquefied gas bottling station microcomputer safety monitoring and scheduling management on-line system, which officially went into full operations in the latter half of 1985.

I. The System Hardware and Software Configuration

This system uses the "Dali"-brand IBM PC compatible as the host machine, having 512K bytes of RAM, two 5" disk drives with 320K bytes of storage each, and is also equipped with a modem, which handles remote communications with the company 60 km away over special telephone lines.

This system was written in BASIC as supported under the CDOS operating system.

II. System Functions

1. Sensing of operational parameters at the bottling station (pressure, liquefaction, flow, and concentration).
2. Over/under warnings for bottling station operational parameters (pressure, liquefaction, flow, and concentration).
3. Dynamic simulated display of bottling station operational parameters.

4. Company controlled--bottling station controlled remote communications on-line, commanding the transmission of data and information.

5. Data processing and reporting for the bottling station scheduling management.

III. Significance and Efficiency

The Dagang Liquefied Gas Bottling Station is the company's largest liquefied gas storage and pressurization station, with bottling capacity of 6,000 cubic meters, and annual provision of about 30,000 tons. Setting up this microcomputer on-line system for safety monitoring and scheduling management has allowed the overall scheduling for the company and bottling station scheduling to be on top of operational parameters promptly and accurately, and has provided warning facilities for various safety incidents. With it, they have realized scientific and automatic scheduling management, and have attained their goal of safe operations and reliable provision of gas. This scheduling system has reached an advanced level in the domestic gas industry, and economic results, safety results, and social results have all been clear.

12586

CSO: 4008/1074

NEW CHINESE-CHARACTER OPERATING SYSTEM DEVELOPED

Tianjin TIANJIN KEJI XIAOXI [TIANJIN SCIENCE & TECHNOLOGY NEWS] in Chinese
No 4 15 Apr 86 pp 12-13

[Manuscript from Zhan Yingmin [2069 5391 3046]: "The HCCDOS Chinese Character Operating System"]

[Text] HCCDOS is a Chinese-character operating system for use on the Corona PC microcomputer as developed by the Computing Department of the Hebei Engineering Academy. This system has been entirely implemented through software. The entire system is stored on one disk. It need not be supported by a color adapter or color monitor, but uses instead the graphics capabilities of the main board and the original equipment green monitor, and may be used by expanding the internal memory to 512K bytes. The input methods for this system are those of zoning, head and tail, spelling, and four rapid common Chinese-character input methods, which allows convenient and rapid input of Chinese characters. The system is supplied with a two-level standard software Chinese-character library in a 16 X 16 matrix. In version 1.0 of this system, each screen can display 11 rows and 40 columns of Chinese characters; in version 2.0, each screen can display 20 rows of 40 columns. The version 2.0 has made full use of the high resolution display, increasing the number of rows for each screen, and improving the amount of displayed Chinese-character information for the convenience of the user. The 9-pin printer driver configured for this system can print 16 different fonts, the smallest of which is only as high as ASCII coded characters, which allows for an ordered, clear page when various Chinese and Western texts are part of a single file. This system is quite software compatible with CCDOS from the Sixth Institute of the Ministry of Electronics. For example, the dBASE II, dBASE III, GW BASIC, and WordStar that normally run under CCDOS operate on this system, allowing users who are familiar with CCDOS to use this system quite easily.

Completion of this system means that users will not have to spend more to buy other graphics cards and color monitors in order to be able to do Chinese-character processing. Reaction from several units using this has been excellent, and the economic results have been clear. It has been quite useful for the modern management of enterprises, for economic management, for scientific and technical management, and for office automation, as well as for departments using computer Chinese character operating systems.

This system has passed all technical evaluations. The evaluations considered that the HCCDOS Chinese character operating system has attained the levels of comparable domestic software, and recommends its dissemination and use.

COMPUTERIZED CADRE PERSONNEL FILES MANAGEMENT SYSTEM

Tianjin TIANJIN KEJI XIAOXI [TIANJIN SCIENCE & TECHNOLOGY NEWS] in Chinese
No 4, 15 Apr 86 pp 13-14

[Article by the Tianjin Municipal Radio Corporation: "Cadre Files Management System Developed on the Dimension Computer"]

[Text] State-run Plant No 712 is a large plant, with more than 1,500 cadre, that each year spends a great deal of time handling cadre statistics and filling out various reports, but where the information has been neither accurate nor prompt. To improve the level of management for cadre files, this plant developed cadre files management on the Dimension microcomputer.

I. The Goals of the Cadre Files Management System

The system goals were first of all to set up a cadre records library file having 30 parameters, on which basis the following goals would be met:

1. Searching: must be able to find a person by name, and the system must output all items for that person.
2. Revision: for revision of certain items for the designated person.
3. Deletion: delete a certain person from the cadre files, then enter all items into a file of deleted persons.
4. Statistics: must do statistics on relevant data in the cadre files.
5. Selection and processing: must output relevant items from a group of records in accordance with certain conditions and requirements.
6. Reporting: must print out relevant reports.
7. Security: there must be security for all system modules.

II. System Analysis

1. Information analysis: the primary items of information for the cadre files of this plant are: name serial number, name, unit, sex, date of birth, racial nationality, political aspect, work index, educational level, level of English, level of Japanese, level of French, level of Russian, personnel category, current position, specialty classification, technical title, date title granted, health situation, date of entrance into the Party, working time, specialty at which working, date of graduation, specialties studied, degrees, and basic wage, and for deleted cadre personnel files there are also the deleted personnel category, disposition, and date when left the plant.

2. The North Star Dimension computer was selected, with dBASE II as the language environment, the combination is convenient, transparent, and easy to master. The dBASE II on this machine has Chinese character capabilities.

3. System Design

This system used data structures to design a main library file and a deleted persons file. The entire system is composed of seven function modules, where each module accomplishes one function, and communication between modules is quite easy. The designers wrote several standard subroutines, which may be called randomly in accordance with the requirements of different applications.

4. Coding Techniques

The contents of some of the items in the cadre files have certain fixed items, such as sex, political aspect, and education level, and this information is categorized before coding. When entering information, it is not necessary to enter Chinese characters, since the corresponding code is entered instead. Using this coding technique greatly improves the rate of information entry, and saves as well as great deal of storage space, so 240K bytes of space is saved for the entire library file. Without coding, cadre record files for the entire plant would require two disks, where now only one is needed, and not only does this save space, but it is more secure as well. Because comparative tables are used in this system, although this input is coded, it is output as Chinese characters.

After the State-Run Plant No 712 began using the microcomputer for files management, management efficiency increased 30 times. This system passed its technical evaluation in December 1985.

12586

CSO: 4008/1074

MICROCOMPUTER ENTERPRISE MANAGEMENT SYSTEM DEVELOPED

Tianjin TIANJIN KEJI XIAOXI [TIANJIN SCIENCE & TECHNOLOGY NEWS] in Chinese
No 4, 15 Apr 86 p 14

[Article by Zhang Yiming [1728 0001 7686], director, Tianjin Municipal Computer Institute: "A Comprehensive Microcomputer Enterprise Management System for Use by Large Commercial Wholesale Departments"]

[Text] The comprehensive microcomputer enterprises management system developed by the Tianjin Computer Institute was successfully developed after more than a year's time and has been placed into production. In December 1985 it was approved by the appraisal committee of organizations of the No 2 Office of Machinery as commissioned by the Tianjin Municipal Science and Technology Commission.

This project used structured programming design methods, and is largely composed of four parts: a comprehensive commodity accounting management system, a statistical report processing system, a wage management system, and an analysis and retrieval system for financial main historical materials. It has been written using CCBASIC and dBASE II, the entire set runs on IBM PC's and compatibles. The comprehensive commodity accounting management system alone will handle about 500,000 first, second, and third level accounts, with a total amount of data of 110MB. In light of the facts that there would be great amounts of user data, a minimum of internal and external storage, different kinds of tasking, and that processing requirements were complex, this system uses several techniques such as reducing redundancy in data, optimizing searches, rapid classification, integration of primary and auxiliary files, automatic detection of free disk space and disk exchange handling, accounts padding and tracing, and common reports handling, which make operations more convenient, and it also makes use of interactive, screen formatted controls and help files prompting information.

The comprehensive commodity accounting management system primarily replaces three levels of accounts for commodities formerly kept by hand, where there is a manual collection of the first and second level accounts and a compilation and print out of various reports. There are functions such as automatic and manual set up of preliminary inventories for the first, second, and third level accounts, then when the three levels of accounts are entered, the system automatically calculates the business and accounting inventories,

automatically collects together the first and second level accounts, sets up and revises various auxiliary and index files, and does general report processing, file copying, and system security management. Among these functions, the general report processing uses unique techniques for writing, can define formats as designed arbitrarily by users, where upon entering the data the system will issue a report or data files and will print out various types of reports. The analysis and retrieval system for historical materials can analyze and compare all primary economic indexes from the station for more than 30 years, which is useful for management personnel to do overall operations analyses and for improving economic management.

Since the entire system has been in operation, the usage situation has been good, it has clearly improved work efficiency, has been of help in the reduction of labor intensity for financial personnel, and has improved accuracy in data. In the opinion of specialists, the design of this system is reasonable, its functions are complete, and each index has met the design requirements, especially the special character of the data compression techniques used, the search, retrieval, and classification techniques, and the general report processing techniques, which have all attained advanced domestic levels. Through a series of technical measures, this system has resolved contradictions between large quantities of data and small computer system capacities to create a successful example for using small computer systems to accomplish large-scale data processing. There is value in disseminating this for management tasking in commercial wholesale departments throughout the country.

12586

CSO: 4008/1074

COMPUTERIZED DESIGN SYSTEM USED FOR TRANSMISSION DESIGN

Tianjin TIANJIN KEJI XIAOXI [TIANJIN SCIENCE & TECHNOLOGY NEWS] in Chinese
No 4, 15 Apr 86 pp 14-15

[Article by Li Hua [2621 5478]: "Transmission Computer-aided Design Software System"]

[Text] The vehicle transmission is one of the eight major assemblies in a vehicle, and it includes numerous typical vehicle components. The Transmission Computer-aided Design Software System designed by the Tianjin Municipal Motor Vehicle Gear Plant is a multipurpose general program for speeding up the development and manufacture of new products. This system has important significance for improving the accuracy of transmissions, for reducing the period for product design, and for hastening the renewal and replacement of products.

System Functions

This system has built eight function modules from nine routines, and uses a series of new standards and new algorithms issued in China in recent years, and can accomplish all the data calculations and some of the technique parameter calculations needed for doing motor vehicle transmission design. The calculation items included in this system are: 1) transmission gear auxiliary geometric parameter calculations; 2) transmission gear auxiliary fatigue and static strength calculations; 3) transmission gear auxiliary parameters and strength comprehensive calculations; 4) transmission drive shaft component parts strength and rigidity calculations; 5) transmission bearing life and reliability calculations; 6) synchronizer performance and life calculations; 7) gear and shaft unkeyed reliability calculations; 8) standard gear geometric parameters calculations.

The entire system may be run successively, where the variables are passed on to the next routine. Each function module can also run alone as an independent routine. This system uses many data files, and stores a great number of foreign and domestic transmission data and a large amount of materials and performance parameters for machinery standard parts, which may be called as needed for calculations. The software is quite general and may not only be used with motor vehicle transmissions, but also for other transmissions and general machinery parts.

System Software

This system was written in BASIC, the source code for which routines are only about 75K bytes, and each function module may be used with the two data formats that either call data files or use keyboard input. The first, second, and third function modules can immediately store keyboard input data, and are flexible and varied. This software system has a powerful Chinese character editing function, and software operations all use either interactive or screen selection formats, and operations are simple and easy to learn. Input and output are both displayed in Chinese characters, and output results may be printed in sets, which allows for easy understanding and convenient reading.

Primary Features

1. Improved calculation precision. Advanced algorithms have been used in the writing of this software, and these have taken into consideration as many factors as possible; there has been no simplification of the numerical models and working conditions of the object of calculation, and therefore there is a higher degree of precision in the calculations. For example, in the fourth function module for "calculating drive shaft associated parts strength and rigidity," the "laws of energy" and "laws of fatigue strength safety coefficients" are used to calculate the deformation and safety coefficients for the drive shaft, and actual practice has shown that the calculation precision is a 60-100 percent improvement over ordinary algorithms.

2. Improved working efficiency. By using new standards and new algorithms, this has increased the degree of complications in the calculation process, and traditional manual methods of calculation take up a great deal of human effort and time without being able to satisfy the demands of precision. By using this system to aid in the design of transmission products, several months of work can be done in an hour, which is a 1,000-fold improvement in efficiency.

This software system that has been developed by the Tianjin Motor Vehicle Gear Plant has shown preliminary results in actual application in the research and production of this plant. At present, the entire software system is being used for the development of new products, and the results of calculations are being used as the basis for proving the design plans for new products.

12586

CSO: 4008/1074

PROGRAMMABLE CONTROLLER SITUATION DESCRIBED

Tianjin TIANJIN KEJI XIAOXI [TIANJIN SCIENCE & TECHNOLOGY NEWS] in Chinese
No 4, 15 Apr 86 pp 16-17

[Article by the Tianjin Institute of Electrical Gear Design: "The Development of and Demand Predictions for Programmable Controllers"]

[Text] The relay based sequential controller has been in use now for more than a century. Since this century, with the development of electrical technology, the sequential controller has evolved through several generations of products, from the electron tube to the transistor, integrated circuits (IC), and large scale integrated circuits (LSI). In the 1960's, with the appearance of minicomputers and because of the demands of production development, people thought of applying computer technology to sequential controllers. In 1969 the American DEC company developed the world's first programmable logical controller (PLC), which uses bit logic operations, and is small, reliable, flexible, and commercially available. With the appearance of microprocessors during the 1970's, because of their powerful performance they could not only do digital operations, but could also do logical operations, and had digital communications capabilities as well. Therefore, the PLC itself was developed into the programmable controller (PC) we have today.

In recent years, the programmable controller has become one of the world's fastest growing automatic control facilities. It is based on advanced microprocessors, and synthesizes computer and electrical control technologies to form a series of products for particular scales of control, and abroad these have been included among industrial electronic equipment products. Programmable controllers have developed for more than 10 years, their levels of technology and product levels continue to improve, and they have the advantages of being highly reliable, tolerant of complex working conditions (ambient temperatures from 0 to 60 degrees Centigrade, humidity from 5 to 95 percent), easy to program, and convenient to install and maintain. They have been well received by factories and plants, and can also meet the demands for process control of various scales that are based on sequential controllers.

Among small PC's, these have generally developed toward the small, simple and easy, and the inexpensive, and also toward having the functions of logical operations, timers, counters, shifts, latches, and drum sequencers, and having 100 or less I/O ports. Among the medium and large scale PC's, in addition to

logical operations they have also added the functions of digital operations, data transmission, matrix logical operations, and also have hardware interrupt input and PID regulating circuits that can be connected with higher level computers and the IBM PC personal computers. Over the last 2 or 3 years, the PC has been connected to CRT displays, and various pictures on the screen can show flowcharts for production techniques. Programmable controllers use relay ladder diagram language, statement tables, or control system flowchart programs, and the more fully featured programmable controllers use language POL programming that is oriented toward process control. The programming languages just mentioned are quite close to the diagram symbols regularly used in project designs, and this is very convenient for project technicians and on-site maintenance personnel doing program design and maintenance. In recent years, with the development of microelectronics and electromechanics, in order to meet the demands of energy conservation, conservation of manpower, improvement of productivity and product quality, and realizing even higher levels of control, PC's also have a definite position in factory automation (FA) and flexible manufacturing systems (FMS). Abroad, PC's are commonly used in the sectors of steelworks, pollution handling, motor vehicle manufacturing, textiles, concrete, foodstuffs, petrochemicals, and electricity generation, transmission and distribution.

As we have just said, foreign PC technology and its applications have grown very quickly, but the level of PC technology in China and the level of products are some 10 years behind that of Japan. During the period of the Seventh 5-Year Plan, as building of the national economy grows, the construction of large unit projects and large amounts of factory technological transformation, as well as much production equipment, are things that are all automated, and the market demand for PC products is quite large. For example, in the second phase of the Baoshan Iron and steelworks project 2050 heat continuous rolling machine automated control system, all facilities in sequential control over the entire production line that use PC's are all fitted with more than 300 of the Siemens Company's S5-110S and S5-150S and the AEG Company's CP80-A800.

In China, we have a series of products with only a few models of micro industrial controllers constructed of unitary microprocessors, which is growing quite quickly. We have only a few finalized designs for PC's made up of ordinary microprocessors (M6800 and the Z80), which do not constitute a series of products and that are limited in their dissemination and applications. The majority of microprocessor control systems for production process control still use single board computers (TP801) or use microcomputer templates (the M6800 series and the Intel 8036 series).

To better develop nationalized PC products, the Tianjin Institute of Electrical Gear Design has initiated research into the development and demand forecasting for programmable controllers, which we will now describe.

I. Forecasting of Market Demands

1. There is still a definite market in China for sequential controllers (chiefly HTL and CMOS devices) because of their simple functions and low prices, and they are also the finalized design products of some plants, which

predict that from 1985 through 1990 production quantities in the several hundreds can still be maintained each year.

2. According to the estimates of production plants and firms, by 1984 there were probably not more than 2,000 industrial micro-controllers used anywhere in the country. Recently, with an onrush of imported PC's, some plants are thinking of shifting to joint ventures or to commission sales of PC products, as from 1987 on the production quantities of these products will tend to decline.

3. In China, we have only a few series of programmable controller products that we have developed on our own, and based on statistics, of the nearly 30,000 units of microcomputers and single board computers throughout the country in 1984, if we figure that 10 percent were used for process control, that means there were only some 3,000. The current trend is to import large numbers of PC's throughout society, as for example where in the first phase of the Baoshan Iron and Steelworks project more than 200 PC's of 15 types were imported from 8 electrical firms in Japan and West Germany and the remainder of PC's only coincidentally appeared in entire sets of equipment for projects such as the Tangshan Fangezhuang coal mine, the Zhuo County Aluminum Products Plant, the Daidong Cement Plant, the Kunming Trisodium Phosphate Plant, the Tianjin Petrochemical Fibers Plant, the Beilun Harbor, and the Qinhuangdao docks. In 1984, there were more than 100 PC's imported singly for civilian purposes (primarily for use in blast furnaces, automatic production lines, harbor loading and unloading, training, maintenance servicing, and education). By 1990 Chinese PC's will prosper with the second phase of the Baoshan Iron and Steelworks project (in 1988 they will import more than 300 PC's), large-scale harbor facilities, power stations, and open-pit mining, at which time there will be another upsurge. Specialists predict that by 1990 the social demand will be: for small-scale PC's (from 64 to 128 I/O ports) $\geq 10^4$, for medium scale PC's (from 128 to 512 I/O ports) $\geq 10^3$, and for large scale PC's (from 512 to 2,048 I/O ports) $\geq 10^2$, so annual demand in society will be equivalent to the number of sales in the Japanese domestic market in 1979 (10,422).

Another market for PC products is to replace relay controller screens, and some plants and research units in this country are currently considering this problem. If the result of evaluations of the performance to cost ratio is that by using PC's to replace relay controller screens there will be clear results, this will further open up the PC market, and the demand for PC's will increase abruptly.

Predicted results show that the primary factors affecting social demand for controller products are backward production techniques, imperfect means of detection, deficiencies in product reliability, and a secondary factor is a lack of clear technology policies from relevant departments regarding the development of various controllers in this country.

For patterns of growth from which China may choose from 1985 through 1990, predictions have shown that: we should primarily develop programmable controllers, and to this end, experts have suggested using imported foreign funding and technology and the models of cooperative production and joint

ventures. These are also the opinions of various specialists in summing up paths of development in this country over the past several years.

The price of imported programmable controllers is rather high (mostly because of high domestic tax rates), and some plants cannot afford to use them. Therefore, we should provide cheaper domestic PC's as quickly as possible.

II. Policies for Dealing with Demand

Experts believe that for various controllers to implement the integration of mechanics and electronics the key problems are: 1) a lack of highly reliable, good performing, and inexpensive series of programmable controllers; 2) the transducers and actuating mechanisms on the PC's are neither complementary nor complete; 3) the manufacturing techniques and the technical equipment for many firms making controllers are backward, and there is a lack of good detection means and quality guarantees.

In comparison with foreign countries, there is still a definite gap between them and China regarding production techniques and sets of products, and we cannot yet satisfy the needs of the domestic market for PC's. Many experts believe that 1) we should clarify as quickly as possible the scales of development and directions of development for domestically produced product series of controllers of all types; 2) we should do model comparisons with foreign PC's and do reverse model and spectrum analyses; 3) we should formulate national standards and testing methods for controllers; 4) we should dissect and analyze the software and hardware of foreign PC's; 5) topics that should be closely studied include: PC programming languages, monitor programs for PC systems, self-diagnostic and communications capabilities in PC's, quality control techniques for PC's, interface techniques for the PC's with color CRT displays and IBM PC personal computers, and I/O expansion techniques.

There are too many types of imported programmable controllers, and some are now obsolete. Some experts are worried that the large number of PC's imported in coming years will affect certain benefits for production firms in those industries in China to some degree. For this reason, we must develop nationalized PC products, and should dissect the software and hardware of preferred foreign PC devices for copying or to alter for domestic models. Because we will not be able to deal domestically with certain large-scale integrated circuits and some electronic components in the immediate future, we should import some of these, for which the state should provide some of the foreign exchange and loans.

12586

CSO: 4008/1074

CIRCUIT DESIGN, ANALYSIS SOFTWARE DEVELOPED

Tianjin TIANJIN KEJI XIAOXI [TIANJIN SCIENCE & TECHNOLOGY NEWS] in Chinese
No 4, 15 Apr 86 pp 16-17

[Article by the Office of Technology, Tianjin Municipal Radio Corporation:
"Improved General Analytical Program for Analog Circuits"]

[Text] The improved general analytical program for analog circuits as developed by the State-Run Tianjin Plant No 712 was written in FORTRAN (version 2.00), and can be run on the IBM PC and its compatibles.

This program can analyze the dc characteristics, ac characteristics, and transient characteristics for any electronic circuit that is composed of common devices such as resistors, inductors, capacitors, coupled mutual inductors, junction diodes, bipolar transistors, controlled power sources, and independent power sources, and can do sensitivity analyses of these. The program affords practically no limit to the scale of circuits.

This program has within it models for junction diodes and bipolar transistors, which the user may use by providing the model parameters.

If there are special devices in the user circuits, a circuit model must first be established for them before analysis can be done. When analyzing circuits on the computer, the first problem encountered is how to tell the computer about the circuit, for this purpose this plant has designed a free-form circuit description language for the user to describe the circuit and set up a circuit description file.

After the user has set up a circuit description file and told the computer about the analysis and output requirements through the screen display, the analysis will immediately begin automatically, and the requested data will be displayed on screen. If it is necessary to record a detailed analysis, the printer may be used.

At the end of 1984, this plant submitted for evaluation a model circuit general analysis program they had developed on the DJS-153, but because they had not used the sparse matrix technique, not only did it run slowly, but it could not analyze smaller scale circuits. Ac and dc analyses were not over 50 nodes, transient analyses were not over 35 nodes, and the program could not

satisfy the ever increasing demands of real circuits. Current use of the sparse matrix technique has improved calculation speed and has expanded the scale of circuits that can be analyzed.

At present, most circuit analysis procedures both in this country and abroad are written in FORTRAN, and they also make wide use of the array data structure to store the component topological data and performance data, as well as the coefficient matrices, solutions, etc., data for the set of circuit equations. When using the arrays, FORTRAN requires use of the DIMENSION statement at the beginning of the entire procedure to define the dimension and size of the array. This is to allocate space for the array in accordance with its size. This requirement of FORTRAN makes it difficult for general analysis programs to fully utilize the memory of the computer because since they are general use programs, they should be able to analyze various different circuits, and since the number of nodes of these circuits and the number of various components differ with particular circuits, these cannot fit with the size of the arrays that are defined at the time the program is written. In addition, these cannot be coordinated between different arrays, invariably because of an excessive number of certain components, which keeps a particular circuit from being analyzed. This plant overcame this deficiency of FORTRAN, in the end not allowing the scale of the circuit to be analyzed to be restricted by the program.

Input for the original program used a question/answer mode for specifying the parameters of the circuit to be analyzed, which is more suitable for smaller scale circuits, and now the scale of analyzable circuits has been improved an order of magnitude, so the plant has used a more convenient way to enter the circuit parameters.

The original program ran on the DJS-153 computer, and was written in FORTRAN IV and FORTRAN V, so to aid in future dissemination and application, the current development runs on the IBM PC/XT microcomputer system, using IBM PC FORTRAN (version 2.00).

12586

CSO: 4008/1074

CHINA'S 1ST MATRIX RESIN FOR COMPOSITES INTRODUCED

Shenzhen SHENZHEN DAXUE XUEBAO (LIGONG BAN) [JOURNAL OF SHENZHEN UNIVERSITY (SCIENCE AND ENGINEERING)] in Chinese Vol 3, No 3, Sep 86 pp 48-56

[Article by Sun Shuchun [1327 2885 3196] and Yang Biao [2799 7374]: "A Study on TDE-85 Epoxy Resin as Matrix Resin for Composite Materials"; first paragraph is source-supplied abstract]

[Text] Abstract: The authors conducted extensive tests on TDE-85 trifunctional epoxy resin (diglycidyl 4,5-epoxy cyclohexane 1,2-dicarboxylate) which was developed and put to industrial use in China as a matrix resin for fiber composite material. The tests show that TDE-85 has good properties among the matrix resin materials used in China and abroad.

I. Introduction

In the development of defense, aerospace, and radio electronic industries, light composite materials with high specific strength and electrical properties are used in place of metals and requirements on composite materials are becoming higher in both quality and quantity.

The performance of a composite depends on the fiber, the matrix (synthetic resin that binds the fibers together) and the forming technology. The types of fibers have gone from just glass fibers to include carbon fibers, boron fibers, and aromatics. The variety of resins is even greater, but at present epoxy is still the main material for advanced composites. In order to further improve the heat resistance, strength and stiffness (modulus) of composites, researchers here and abroad have developed a number of new epoxy systems that are superior to the usual bisphenol-A epoxy; a number of them have been put to industrial use in China.¹ This paper describes the new TDE-85 epoxy resin developed in China and first put into industrial production.

The chemical name of TDE-85 epoxy is diglycidyl, 4,5-epoxy cyclohexane 1,2-dicarboxylate. It is a trifunctional resin with low viscosity (about 1/10 of that of E-51 epoxy), high reactivity, and good manufacturing properties. It can be hardened with amide, aromatic amine, and acid anhydride hardeners. The cured solids have high heat resistance, high strength, high modulus and good electrical insulation properties.^{1,2}

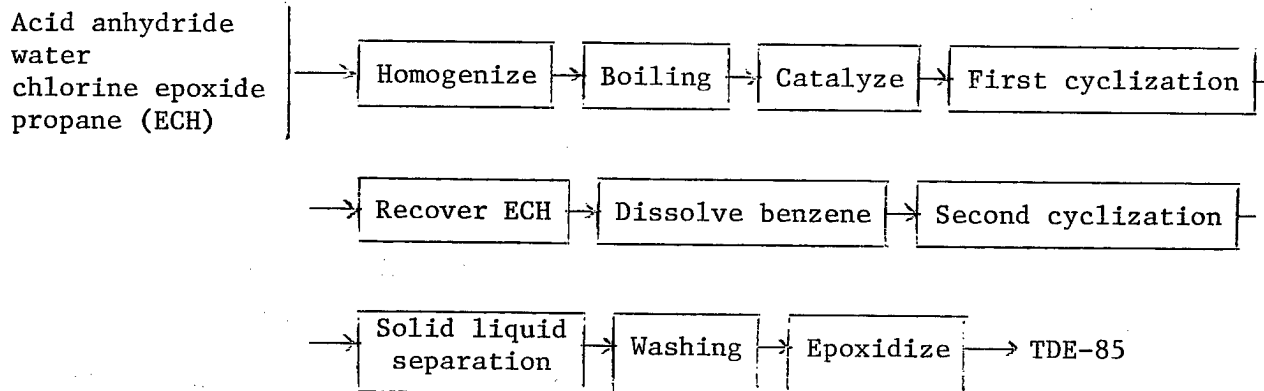

2. Product specification

Structure formula:

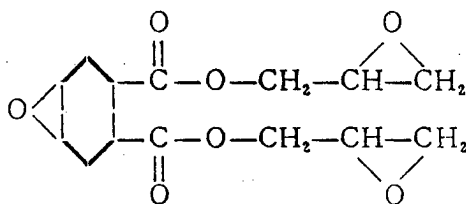

Molecular weight: 298;

Epoxy value: >0.85 mg equivalent/100 g;

Organic chlorine: <0.02 mg equivalent/100 g;

Inorganic chlorine: <0.001 mg equivalent/100 g;

Volatile: <1.0 percent;

Viscosity: 2,000-3,000 centipoise (25°C rotational viscosimeter);

Stability: stable below 200°C, polymerization begins at 200°C;

Appearance: light yellow transparent liquid.

II. Effects of Hardeners on TDE-85 Epoxy Composite Performance

Since the molecule of TDE-85 epoxy has two diglycidyls, it is different from the usual epoxy and reacts miscibly with almost any epoxy hardeners. In this work attention is given to the TDE-85 epoxy cured by amide and acid anhydride hardeners.

1. Amide hardeners

Table 1. Formula 1

Composition	TDE-85	Tonox6040 ¹⁾	ERL 4206 ²⁾
Ratio	100	57	45
Hardening conditions	85°C, 3 hrs → 100°C, 3 hrs → 150°C, 6 hrs		

- 1) A low melting hardener consists of a 60:40 mixture of m-tolylenediamine and 4.4-diamine diphenolmethane.
- 2) The chemical name of ERL-4206 is ethylene dioxide hexene and the structure formula is

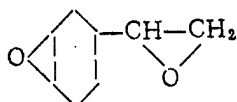

8 centipoise at 25°C

Formula 1 is a typical example for wet filament winding. Because the composition contains an active ERL-4206 epoxy dilutant similar in molecular structure as TDE-85, the miscibility is quite good. Viscosity of the resin system is an important parameter for filament winding. Figure 1 shows the viscosity of formula 1 at 25°C.

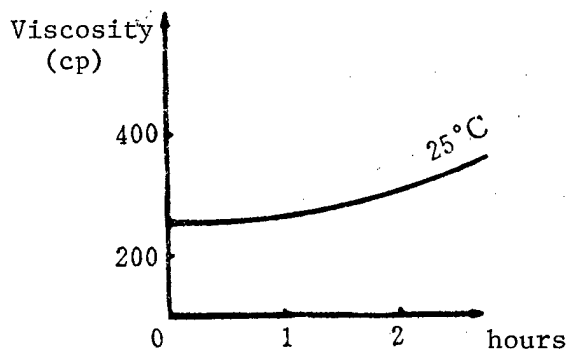

Figure 1. Viscosity of Formula 1

As can be seen from Figure 1, the change in viscosity at 25°C is small. The viscosity remains below 400 centipoise for 3 hours and is suitable for filament winding.

Table 2. Room Temperature Properties of Formula 1 Cast

Test item	Performance
Martin heat resistance °C	180
Tensile strength kg/cm ²	710
Tensile modulus kg/cm ²	4.00 x 10 ⁴
Extension (percent)	2.00
Compressive strength kg/cm ²	1820
Compressive modulus kg/cm ²	4.8 x 10 ⁴
Bending strength kg/cm ²	1200

Table 3. Test Results of Single Phase Formula 1 Ring at Room Temperature

Test No	GFRP			CFRP		
	Tensile strength kg/cm ²	Shear strength kg/cm ²	Bending strength kg/cm ²	Tensile strength kg/cm ²	Shear strength kg/cm ²	Bending strength kg/cm ²
1	12500	710	13590	8070	350	14130
2	12800	710	13980	7360	390	13860
3	10200	730	14260	10100	370	11900
4	12000	600	11800	7610	360	11160
5	13000	710	13300	8300	390	9420
Average	12100	700	13380	8300	370	12000
Resin content: 25.3%, curing: 97.3%				30% resin, 95% curing		

Table 4. Test Results at 100°C of Formula 1 Cast

Test item No	Tensile strength kg/cm ²	Elastic modulus kg/cm ²	Extension rate %	Bending strength kg/cm ²
100°C 1	570	3.7 x 10 ⁴	1.8	1130
2	855	3.6 x 10 ⁴	2.6	1120
3	900	3.5 x 10 ⁴	1.7	910
4	800	3.5 x 10 ⁴	3.5	1030
5	880	3.7 x 10 ⁴	2.9	1130
Avg.	800	3.6 x 10 ⁴	2.7	1170
Room temp data	710	4.0 x 10 ⁴	2.0	1200

Data in the table show that the mechanical properties of formula 1 are not only good at room temperature, but also at 100°C. It is therefore an ideal material for making GFRP and CFRP. Carbon fiber reinforced composites using this formula have already been used in critical components with an operating temperature of 100°C.

2. Acid anhydride hardener

Table 5. Formula 2

Composition	TDE-85	Anhydride No 70 ¹⁾	BOMA ²⁾
Mixing ratio	100	110	1
Hardening	90°C/3 hr + 120°C/4 hr + 160°C/6 hr		

- 1) Anhydride No 70 is a Chinese-made liquid acid anhydride. It is an isomer of tetrahydrobenzene dimethylamine with a molecular weight of 152.
 2) BMA is a promoter, N,N-dimethyl benzyaniline.

Table 6. Test Results of Formula 2 Cast

Tests	Results
Martin heat resistance °C	156
Tensile strength kg/cm ²	630
Tensile modulus kg/cm ²	3.5 x 10 ⁴
Extension, %	2.1
Bending strength kg/cm ²	1690
Compressive strength kg/cm ²	1630
Resistivity Ohm-cm	3.4 x 10 ¹⁶
Dielectric constant ε	3.17
Loss tangent tgδ	2.2 x 10 ⁻²

Table 7. Properties of Formula 2 CFRP Unidirectional Panel

Test direction	Test item	Room temp	100°C
90°	Tensile strength	264	245
	Tensile modulus	9.48 x 10 ⁴	5.47 x 10 ⁴
0°	Tensile strength	11000	
	Tensile modulus	1.01 x 10 ⁶	
45°	Shear strength	187	

Note: Units are kg/cm²

Since the TDE-85 resin wets and adheres to carbon fibers strongly, the quality and mechanical properties of composites made of formula 2 are very good.

Table 8. Formula 3

Composition	TDE-85	MNA ¹⁾	BDMA	GY-1252JP ²⁾
Ratio	90	130	1	10
Hardening conditions	90°C, 3 hrs → 120°C, 4 hrs → 150°C, 6 hrs			

- 1) MNA is a low melting heat resistant acid anhydride. Chemical name is sodium methyl sec-methyl tetrahydrobenzene dimethylamine and the molecular weight is 178.
- 2) Low viscosity bisphenol A epoxy imported from Japan, epoxy value 0.50.

Table 9. Properties of Formula 3 Cast

<u>Test item</u>	<u>Performance</u>
Martin heat resistance °C	154
Tensile strength kg/cm ²	600
Tensile modulus kg/cm ²	3.45 x 10 ⁴
Extension, %	2
Bending strength kg/cm ²	1000
Linear coefficient of expansion x10 ⁻⁶ C ⁻¹	1.27

Table 10. Test Results of Single Phase GFRP Ring Using Formula 3

<u>Test item</u>	<u>Performance</u>
Tensile strength kg/cm ²	13000
Tensile modulus kg/cm ²	1.46 x 10 ⁶
Bending strength kg/cm ²	6960
Interlaminar shear strength kg/cm ²	500
Resin content, %	30

Table 11. Mechanical Properties of Single-Phase CFRP Panel Using Formula 3

Test direction	No.	Elastic modulus (x10 ⁴ kg/cm ²)		Poisson ratio γ	Shear modulus (x10 ⁴ kg/cm ²)	Ultimate strength (kg/cm ²)
		Extensometer	Strain gauge			
0°	1	104.0	104.0	0.27	--	--
	2	100.0	105.6	0.32	--	11330
	3	104.0	107.7	0.31	--	--
90°	1	9.35	10.7	0.031	--	280
	2	9.21	10.0	0.030	--	245
	3	9.31	10.4	0.028	--	355
45°	1	13.4	13.5	0.334	5.08	564
	2	12.3	12.8	0.285	4.92	484
	3	11.1	11.1	0.291	4.25	525

Table 12. Electrical Properties of Formula 3 GFRP Composite

Test item	Test results
Dielectric constant	3.71
Loss tangent	1.6 x 10 ⁻²

Note: Test temperature 100°C, test frequency 9375MHz.

From the test results, formula 3 has not only good mechanical properties, but also unique electrical properties at 100°C. This is a rare combination for aerospace materials.

III. Conclusions

Since TDE-85 is trifunctional, has a high cross linking density, and has both the advantages of alicyclic epoxy and glycidyl epoxy, it has high strength, high modulus (stiffness), good adhesion, superior electrical properties, weather resistant, and good high temperature properties. Composites made of TDE-85 are especially good, not only the room temperature mechanical properties are good, the mechanical performance remains good at 100°C as well. It is therefore a good matrix material for composites.

All the materials used in the production of TDE-85 came from China. The technology is now mature and the potential for application is very good.

REFERENCES

1. Yang Biao, "Introduction to Epoxies," BOLIGANG FUHE CAILIAO [GLASS FIBER REINFORCED COMPOSITES], No 5, 15, 1985.

2. Xu Zongxiong [1776 4912 7160] and Zhou Xiaozheng [0719 1420 2398], "Application of TDE-85 in High Temperature Adhesives," ZHANJIE [ADHESION], No 3, 28, 1983.
3. Huang Jifu [7806 0679 3940], Zhang Baolong [1728 0202 7893], Wang Derun [3769 1795 3387], Yang Biao, and Liu Zhixin [2692 1807 2946], "Morphology and Dynamic Mechanical Behavior of Diglycidyl 4.5-epoxy cyclohexane 1.2-dicarboxylate," GAOFENZI TONGXIN [HIGH POLYMER COMMUNICATIONS], No 5, 385, 1983.
4. Huang Jifu, Zhang Baolong, Wang Derun, and Yang Biao, "Curing Behavior of Diglycidyl 4.5-epoxy cyclohexane 1.2-dicarboxylate," GAOFENZI TONGXIN, No 6, 414, 1983.
5. Qiu Henian [6726 7729 1628] and Huang Suqin [7806 4790 3830], "Characteristics and Applications of TDE-85 Epoxy Resin," HUANJING SHUZHUYINGYONG JISHU [APPLICATION TECHNOLOGY OF EPOXY RESIN], No 1, 1984.

9698/6091

CSO: 4008/1063

NEW, FAST THINNING ALGORITHM FOR BINARY DIGITAL IMAGES

Chongqing CHONGQING DAXUE XUEBAO [JOURNAL OF CHONGQING UNIVERSITY] in Chinese
Vol 9, No 3, Sep 86 pp 63-69

[Article by Chen Yuxin [7115 1342 2450] of the Radio Department, Zhang Taiyi [1728 1132 1837] of the Automation Department, and Jin Jicheng [6855 0679 2052] and Li Shiguang [2621 2514 0342] of the Radio Department, Chongqing University; paper received 24 December 1985; first paragraph is source-supplied abstract]

[Text] Abstract: This paper proposes a new, fast thinning algorithm for binary digital images composed of two steps: 1) Removing the contour points from the four boundaries at the same time and making the image into a sub-image composed of single layer pixels or double layer pixels. 2) Postposition processing: using serial methods to convert the double layer pixels into the desired thinned image skeleton composed of single layer pixels and to ensure the connectivity of its skeleton. Experimental results prove that this method is fast and efficient.

I. Introduction

Thinning is an important preprocess of image processing and pattern recognition that compresses the amount of data that must be processed and is a means to provide a simplified image which preserves the characteristics of the original. This so-called thinning also takes a discrete binary multilayer pixel image and converts it into an image skeleton which only has single layer pixel thickness. This skeleton preserves the useful information of the original image both in terms of topology and geometry. Therefore, the thinning operation must satisfy these requirements: 1) Preserve the connectivity of the image after thinning. 2) Maintain the shape of the original image.

The study of thinning algorithms is already several years old and there are now many different thinning algorithms. However, people still seek simpler and faster algorithms to increase processing speed.

Previously adopted four or two step methods stripped off contour points layer by layer from one or two directions. To thin an image this way required quite a few procedures and a fairly long time. Although

D. Rutovitz [8] and C. Judith Hilditch [7] both adopted a thinning method removal of all four borders, the first has severe shrinkage and the decision conditions of the second are pretty complex so both methods are comparatively wasteful of time.

This paper, on the foundations of the conditions for preserving image connectivity provided in reference [1], undertakes improvement of their two step method by providing a one step method and adopting simpler algebraic operation criteria to increase the operating speed.

II. Definitions

The eight neighboring pixels of the sample pixel, P_1 are as shown in Figure 1.

P_9 (i-1, j-1)	P_2 (i-1, j)	P_3 (i-1, j+1)
P_8 (i, j-1)	P_1 (i, j)	P_4 (i, j+1)
P_7 (i+1, j-1)	P_6 (i+1, j)	P_5 (i+1, j+1)

Figure 1

Definition 1: Set $\{P_K \mid K = 2, 4, 6, 8\}$ is called the four neighbor pixels of sample pixel P_1 ; Set $\{P_K \mid K = 2, 3, \dots, 9\}$ is called the eight neighbor pixels of sample pixel P_1 ; and Set $\{P_K \mid K = 3, 5, 7, 9\}$ is called the diagonal neighbor pixels of sample pixel P_1 .

Definition 2: The picture elements of the image en bloc are set R. The set of pixels in R with a value of 1 are represented as Q and those with a value of 0 are represented as \bar{Q} .

Definition 3: If a certain picture element has at least one of the four neighbor pixels belonging to \bar{Q} , then define this picture element as a contour point and represent the set of contour points by Q' .

For example, in Figure 1, if sample pixel P_1 has the value 1, if at least one of the pixels, P_2, P_4, P_6, P_8 has a value of 0, then we say that sample pixel P_1 is a contour point.

III. Thinning Algorithm

Using 2-dimensional arrays IP and MI to represent binary discrete point sets in a plane, define the binary functions IP(P) and MI(P), and use the point set of IP(P) = 1 to represent the digitized image and the point set of MI(P) = 1 to represent the digitized image contour points.

The algorithm is divided in two parts:

Procedure I, one step method (strip off the perimeter outline points)

1. If $N(P_1) < 4$, then $MI(P_1) = 1$.

in which: $N(P_1) = P_2 + P_4 + P_6 + P_8$

$N(P_1)$ is the sum of the four neighbor pixels of sample pixel P_1 in the IP array. If it is less than 4, then there is at least one pixel in the four neighbor pixels belonging to Q bar. Satisfying the contour point definition then the sample pixel P_1 is a contour point.

2. If $IP(P) = MI(P)$ jump to procedure II.

If $IP(P) = MI(P)$ it means that all the picture pixels in the image are contour pixels. The picture at this time is composed of single layer picture element pixels or double layer picture element pixels and we jump to procedure II to carry out postposition processing to further eliminate multiple layer pixels but also maintain the picture connectivity.

3. If:

(a) $A(P_1) \neq 1$, or

(b) $B(P_1) \neq 0$.

then $MI(P_1) = 0$.

in which: $A(P_1)$ and $B(P_1)$ respectively are undergoing computation in arrays IP and MI.

$$A(P_1) = \sum_{K=2}^8 \bar{P}_K \cdot P_{K+1} + \bar{P}_0 \cdot P_2$$

P_2, P_3, \dots, P_9 are pixels in image array IP.

If $A(P_1) \neq 1$, then it is easy to prove sample point P_1 is not an end point of this picture. Moreover, sample point P_1 serves the function of connecting with respect to the other eight pixels in the 3×3 window of P_1 so it should not be eliminated and we set $MI(P_1) = 0$.

For example, as shown in Figure 2:

$$\begin{aligned} A(P_1) &= \sum_{K=2}^8 \bar{P}_K \cdot P_{K+1} + \bar{P}_0 \cdot P_2 \\ &= \bar{P}_2 \cdot P_3 + \bar{P}_0 \cdot P_7 \\ &= 2 \end{aligned}$$

sample point P_1 should not be eliminated.

(1)		
0	0	1
1	P_1	0
1	0	0
(2)		

Figure 2

$$B(P_1) = P_2 \cdot P_4 + P_4 \cdot P_6 + P_6 \cdot P_8 + P_8 \cdot P_2$$

P_2, P_4, P_6, P_8 are pixels in the image contour array $MI(P)$. As we can see in Figure 3 with respect to multilayered pixels $B(P_1) \neq 0$.



Figure 3

This is to say, if $B(P_1) \neq 0$, then in the 3×3 neighborhood of pixel P_1 , there are two neighboring four neighbor pixels that are not zero at the same time. Pixel P_1 and these two four neighbor pixels form a multilayer pixel at which time pixel P_1 ought to be preserved.

The decision for $B(P_1)$ is a series operation. Horizontal and vertical multilayered pixels can have one layer eliminated in procedure I to become single layer. As Figure 4(a) shows, let pixel \oplus be sample pixel P_1 . Compute $B(P_1) = 1$ as a multilayered pixel, set $MI(P_1) = 0$, and preserve sample point P_1 . Again let the pixel on its right be sample point P_1 , carry out judgment, $B(P_1) = 0$, set $MI(P_1) = 1$, and eliminate sample pixel P_1 . Corresponding judgments can be made for the other pixels in Figure 4(a) and finally the multilayered pixels are transformed into single layer pixels. A similar analysis can be done for Figure 4(b). So in procedure II we need only perform processing on the multilayer pixels along the diagonal.

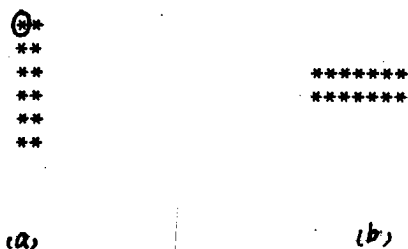

Figure 4

4. IP(P) - MI(P) jump to 1.

Strip off the contour pixel jump to 1. Repeat the above process.

Procedure II, postposition processing: using a serial process thin the multilayered pixels into single layered pixels.

Conditions:

If

$$F = P_2 \cdot P_4 \cdot \bar{P}_6 \cdot \bar{P}_7 \cdot \bar{P}_8 + P_4 \cdot P_6 \cdot \bar{P}_8 \cdot \bar{P}_9 \cdot \bar{P}_2 + P_6 \cdot P_8 \cdot \bar{P}_2 \cdot \bar{P}_3 \cdot \bar{P}_4 + P_8 \cdot P_2 \cdot \bar{P}_4 \cdot \bar{P}_6 \cdot \bar{P}_8 \neq 0$$

then IP(P₁) = 0.

That is, if satisfying one of the four conditions in Figure 5 set sample point P₁ to 0. It is evident that P₁ forms a multilayer pixel with the four neighbor pixels in the neighborhood in addition to having no effect on the image connectivity so pixel P₁ is a contour point which can be eliminated. However, the criteria still preserves the picture pixels of the corner as shown in Figure 6.

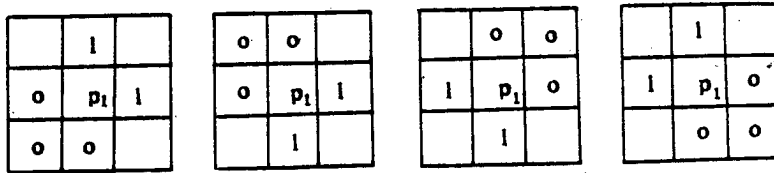

Figure 5

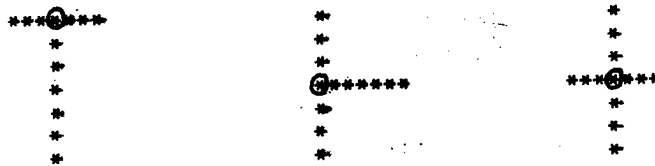

Figure 6

In the program schematic as shown in Figure 7, M counts the number of picture pixels which are not contour points. If M = 0 it means that IP(P) = MI(P) and transfers to procedure II to change the multilayer pixels into single layer pixels.

In reference [1] operation speed comparisons were done between their method and the four and two step methods of A. Rosenfeld, see Table 1. Now we have made comparisons between the fast thinning algorithm proposed in this article and the algorithm introduced in reference [1]. The two algorithms were both

written in FORTRAN and run on an IBM microcomputer. The operation times are given in Table 2. Times are recorded in seconds.

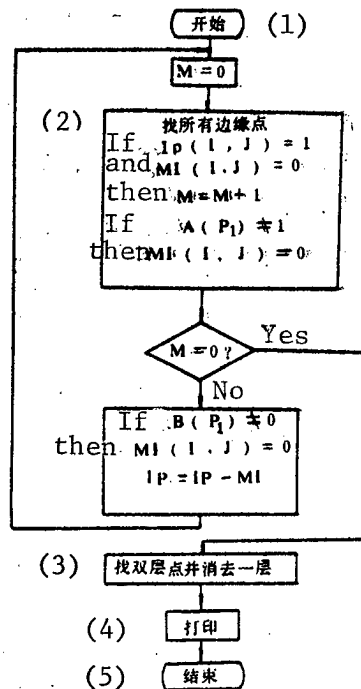

Figure 7

Key:

- | | |
|--|----------|
| 1. Start | 4. Print |
| 2. Find contour points | 5. End |
| 3. Find double points and remove one layer | |

Table 1

Pattern	Method		
	Four step method	Two step method	Method of reference [1]
B	0.765	0.678	0.454
Skeleton	1.031	0.882	0.505
Moving man	2.713	2.221	1.163

Table 2

Pattern	Method	
	Zhang and Suen method	Our method
Character "grove"	10.22	9.01
Letter B	3.08	2.09
Chromosome	3.95	2.97
Character "skill"	6.10	5.11
Letter n	7.47	5.99

When used to do thinning on certain special shapes, the algorithm of reference [1] will produce distortion as shown in Figure 8.

The algorithm proposed here reduced distortion and increased the ability to maintain the image's useful information. See Figure 9.

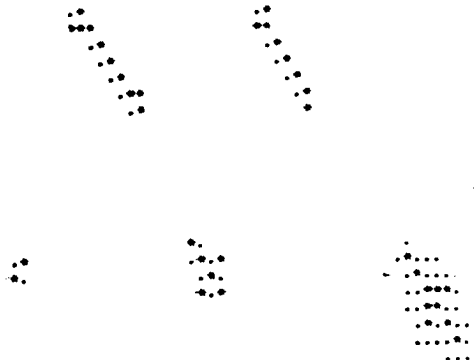

Figure 8

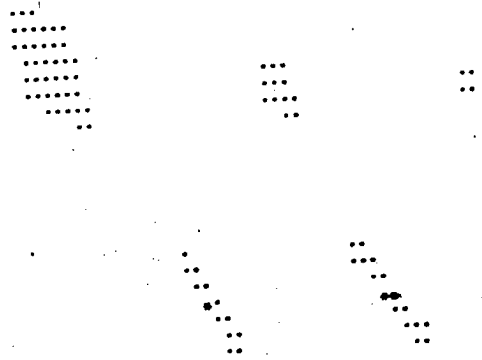

Figure 9

Figures 10, 11, 12, 13, and 14 give the thinning results of our algorithm on the patterns of the character lin "林" (grove), a chromosome, the letter "B", the character ji "技" (skill), and the letter "n".

(Note: "." is a picture point eliminated after thinning and "*" is a point retained after thinning.)

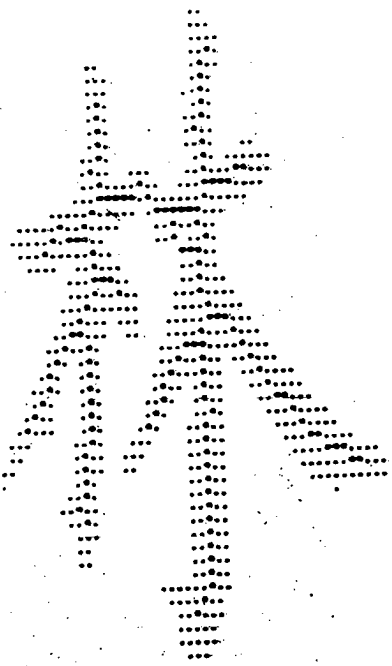

Figure 10

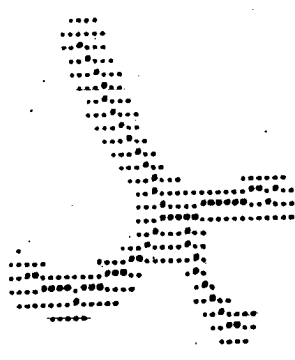

Figure 11

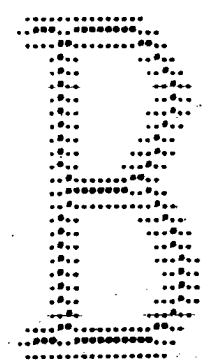

Figure 12

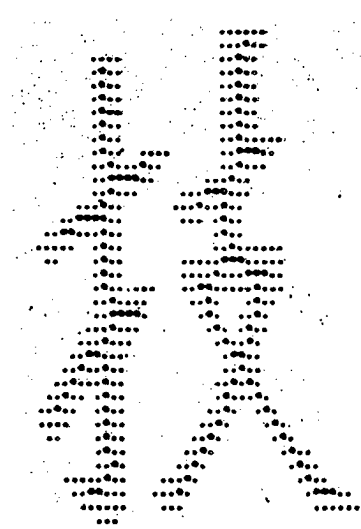

Figure 13

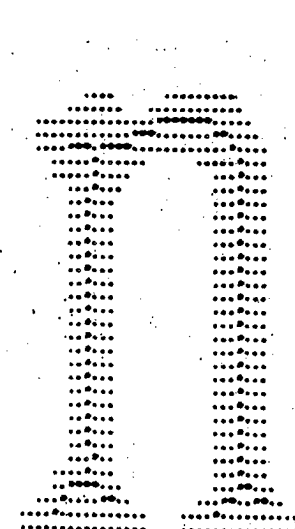

Figure 14

Conclusion

Due to the adoption of a method that eliminated contour pixels simultaneously on all four sides, we obtained more rapid operation. From the thinning results on several different patterns, it is clear that the thinning algorithm proposed by this paper is fast and efficient and is capable of preserving more of the skeletal information for certain images with special shapes.

REFERENCES

1. Zhang, T.Y. and C.Y. Suen, "A Fast Algorithm for Thinning Digital Patterns," *Comm. of the ACM*, Vol 27, No 3, March 1984.
2. Zhang Shengrum and K.S.L. Fu, "A Thinning Algorithm for Discrete Binary Images," *Proc. of the First Int. Conf. on Computers and Applications*, June 1984.
3. Zhang Shengxun [1728 5110 6064], "Thinning Algorithms for Discrete Binary Images," *ZHEJIANG DAXUE XUEBAO [JOURNAL OF ZHEJIANG UNIVERSITY]*, March 1984.
4. Sefanelli, R. and A. Rosenfeld, "Some Parallel Thinning Algorithms for Digital Pictures," *Journal of the Association for Computer Machinery*, Vol 18, No 2, April 1971.
5. Arcelli, C., "Pattern Thinning by Contour Tracing," *Computer Graphics and Image Processing*, 17, pp 130-144, 1981.
6. Lu, H.Y. and P.S.P. Wang, "A Comment on 'A Fast Parallel Algorithm for Thinning Digital Patterns'" (forthcoming).

7. Hilditch, C.J., "Linear Skeletons From Square Cupboards," in Machine Intelligence IV, Ed. by B. Hertzner and D. Michie (Edinburgh: University Press, 1969), pp 403-420.
8. Rutovitz, D., "Pattern Recognition," JOURNAL OF THE ROYAL STATISTICAL SOCIETY, Series A, Vol 129, pp 504-530, 1966.

12966/6091
CSO: 4008/1065

NEW COMPLEX TYPE OF ABNORMAL HEMOGLOBIN: Hb G-CHINESE COMBINED WITH Hb J-BANGKOK

Beijing SHENGWUHUAXUE YU SHENGWUWULI JINZHAN [BIOCHEMISTRY AND BIOPHYSICS] in Chinese Vol 18 No 3, May 86 pp 227-231

[English abstract of article by Zeng Yitao [2582 3300 3325], et al., of the Laboratory of Medical Genetics, Shanghai Children's Hospital; He Zengrong [0149 1073 2837], et al., of Jiaoling County People's Hospital of Guangdong Province]

[Text] This paper describes a new complex type of abnormal hemoglobin. The proposita was a 15-year-old girl living in Jiaoling County of Guangdong Province. Routine hematological examination revealed normal findings, except for a slightly higher frequency in the Heinz body occurrence. Cellulose acetate electrophoresis showed two types of abnormal hemoglobin (fast- and slow-moving variants) in her hemolysate. The relative amounts of these two variants were 54.5 percent and 11.9 percent, respectively. A family study showed that her father carried the slow-moving variant and her mother the fast-moving one. Chemical structural analysis indicated that the fast-moving variant is Hb J-Bangkok ($\beta 56(D7)Gly \rightarrow Asp$) and the slow moving variant Hb G-Chinese ($\alpha 30(B11)Glu \rightarrow Gln$). (Paper received 28 Jul 84.)

REFERENCES

- [1] 黄淑顿等: 上海地区 520 名健康人血红蛋白正常值。上海医学, 1980, 3, 468。
- [2] 曾溢滔、黄淑顿: 在中国发现的异常血红蛋白的化学结构研究。生物化学与生物物理学报, 1984, 16, 270。
- [3] Vella, F. et al. An abnormal haemoglobin in a Chinese; Haemoglobin G. *Nature*, 1958, 180, 460.
- [4] 曾溢滔等: 血红蛋白 G-Chinese 的结构分析。上海医学, 1982, 5, 125。
- [5] Clegg, J. B. et al. Abnormal human haemoglobins. Separation and characterization of the α and β chains by chromatography, and the determination of two new variants. *J. Mol. Biol.*, 1966, 19, 91.
- [6] 易顺成等: 血红蛋白 J-Bangkok 一家系的报告。江西医药, 1982 (6), 57。
- [7] 陈松森等: 我国异常血红蛋白的研究: 3例 Hb J-Bangkok 及其一级结构分析。中国医学科学院学报, 1982, 4, 1。
- [8] 严运坤等: 血红蛋白 J-Bangkok (曼谷) 一例报告。第二军医大学学报, 1983, 4, 25。
- [9] Baglioni, C. et al. Abnormal human haemoglobins V. Chemical investigation of haemoglobins A, G, C, X from one individual. *Biochimica et Biophysica Acta*, 1961, 48, 253.
- [10] Craggs, M. H. et al. Homozygous sickle-cell anaemia arising from two different haemoglobins, interaction of haemoglobins S and Stanleyville-11. *Br. Med. J.*, 1964, 2, 87.

- [11] Krans, A. P. et al. A new variety of sickle cell anemia with clinically mild symptoms due to an α chain variant of hemoglobin ($\alpha^{23}\text{GluNH}_2$). *J. Lab. Clin. Med.*, 1965, **66**, 886.
- [12] Bunn, H. F. et al. Hemoglobin Aida ($\alpha^{64}\text{Asp}\rightarrow\text{Asn}$) and D-Los Angeles ($\beta^{121}\text{Glu}\rightarrow\text{Gln}$) in an Asian-Indian family. *Hemoglobin*, 1978, **2**(6), 531.
- [13] 陈松森等:一例新的血红蛋白复合类型——血红蛋白 I 复合血红蛋白 II 的化学结构分析。中国医学科学院学报, 1983, **5**, 29。
- [14] 杨克恭等:一种新的血红蛋白复合类型——Hb 武鸣-文昌复合 Hb E。中华医学杂志, 1984, **64**, 318。

9717

CSO: 4009/1094

PRIMARY STRUCTURE ANALYSIS AND FUNCTIONAL STUDY OF CASE WITH Hb LILLE

Beijing SHENGWUHUAXUE YU SHENGWUWULI JINZHAN [BIOCHEMISTRY AND BIOPHYSICS]
in Chinese Vol 18 No 3, May 86 pp 232-238

[English abstract of article by Lu Yiqin [4151 5030 2953], et al., of the Department of Biochemistry, Hunan Medical College, Changsha; Chen Songsen [7115 2646 2773], et al., of the Institute of Basic Medical Sciences, Chinese Academy of Medical Sciences, Beijing; Zuo Changrong [1563 2490 2837] of the Clinical Laboratory, Jianghua County Hospital]

[Text] A slow-moving α -chain hemoglobin variant, accounting for 14.5 percent of the individual's total hemoglobin, was found in Hunan Province. This proband was a young man of the Yao ethnic group (one of the national minorities of China). A family study revealed that three of seven members carried the same abnormal Hb. All of them were heterozygotes and manifested neither clinical symptoms nor hematological abnormalities. Primary structure analysis confirmed identity with Hb Lille [α 74(EF3)Asp \rightarrow Ala].

The absorption spectrum (460-740 nm) and oxygen equilibrium of the chromatographically purified Hb Lille showed characteristics similar to those of purified Hb A. The interrelationship between the structure and function of Hb Lille is briefly discussed. This is the first case of this kind reported in China. (Paper received 2 Aug 84.)

REFERENCES

- [1] Djoumessi, S. et al. Hemoglobin Lille, α_2 [74(EF3)Asp \rightarrow Ala] β_2 . *Hemoglobin*, 1981, **5**, 475.
- [2] 方暨岚、卢义钦等: 湖南地区 2437 人中异型血红蛋白的初步报道。湖南医学院学报, 1980, **5**, 28.
- [3] 中国遗传学会人类和医学遗传委员会血红蛋白病研究协作组编: 血红蛋白病普查检验方法(试用本), 1980, 16.
- [4] Huisman, T. H. J. and Jonxis, T. H. P. The hemoglobinopathies. *Techniques of Identification*, Chapter 4, *Methods*, 1977, 142, Marcel Dekker, Inc., New York.
- [5] 卢义钦等: 见于湖南的一例血红蛋白 J 曼谷及其一级结构分析。生物化学与生物物理学报, 1983, **15**, 151.
- [6] 刘德培等: 薄层指纹技术分析异型血红蛋白一级结构 I. 正常血红蛋白 β 链薄层指纹及血红蛋白 E 结构分析。湖南医学院学报, 1982, **7**, 153.
- [7] Chang, J. Y. et al. Micro-sequence analysis of peptides and proteins using 4-N,N-dimethylaminoazobenzene 4'-isothiocyanate/phenylisothiocyanate double coupling method. *FEBS Lett.*, 1978, **93**, 205.
- [8] Chang, J. Y. Amino-terminal analysis of polypeptide using dimethylaminoazobenzene isothiocyanate. *Anal. Biochem.*, 1980, **102**, 384.
- [9] 黄承汉等: 四例异型血红蛋白的氧平衡。湖南医学院学报, 1983, **8**, 235.

- [10] Blackwell, Q. R. and Liu, C. S. Hemoglobin G Taichung: $\alpha 74$ Asp \rightarrow His. *Biochim. Biophys. Acta*, 1970, **200**, 70.
- [11] Brimhall, H. et al. Structural characterizations of Hemoglobins J Buda [$\alpha 61$ (E10) Lys \rightarrow Asn] and G Pest [$\alpha 74$ (EF3) Asp \rightarrow Asn]. *Biochim. Biophys. Acta*, 1974, **336**, 344.
- [12] Orringer, E. P. et al. Hemoglobin Chapel Hill or $\alpha_2 74$ Asp \rightarrow Gly β_2 . *FEBS Lett.*, 1976, **65**, 297.
- [13] Sack, J. S. et al. Location of amino acid residues in human deoxy hemoglobin. *Hemoglobin*, 1978, **2**, 153.
- [14] 黄承汉: 异常血红蛋白的氧亲和力与构象。国外医学——分子生物学分册, 1984, **6**(1), 15。

9717

CSO: 4009/1094

EFFECT OF ESTROGEN ON HIGH DENSITY LIPOPROTEIN METABOLISM IN RATS

Beijing SHENGWUHUAXUE YU SHENGWUWULI JINZHAN [BIOCHEMISTRY AND BIOPHYSICS]
in Chinese Vol 18 No 3, May 86 pp 252-257

[English abstract of article by Chen Qi [7115 3825], et al., of the Department
of Biochemistry, Faculty of Pharmacy, Shanghai Medical University]

[Text] The serum HDL-C level and HDL-C/TC, HDL-C/LDL-C ratios of ovariectomized normal female rats after administration of 17- β -estradiol for two weeks (group I: 2.5 μ g estradiol/day; group II: 125 μ g estradiol/day) were increased, while the serum LDL-C level and LDL-C/TC were decreased. The binding and uptake of rat 125 I-HDL by rat hepatocytes were increased in the rats treated with estrogen, while the degradation of rat 125 I-HDL was unchanged. In addition, it has been found that the concentration of HDL-C in rat liver perfusate was elevated in rats treated with estrogen. From these results, the authors suggest that estrogen might increase the synthesis and/or secretion of HDL from rat liver and this effect might be greater than that caused by the uptake and degradation of HDL by rat hepatocytes. This might be the major reason for the increase of rat serum HDL-C levels after estrogen treatment. In rats treated with estrogen, the activity of serum LCAT was increased and the activity of post-heparin plasma HEL was decreased, but post-heparin plasma LPL was unchanged. The effects on LCAT and HEL might contribute to the increase of rat serum HDL-C. (Paper received 9 Feb 85.)

REFERENCES

- [1] Glueck, C. J. et al. Hyperalpha- and hypobeta-lipoproteinemia in octogenarian kindreds. *Atherosclerosis*, 1977, **27**, 387.
- [2] Robert, A. T. et al. *Screening Methods in Pharmacology*, 1971, **2**, 90.
- [3] 韩琴琴等: 应用国产酶试剂测定血清胆固醇的方法. 上海第一医学院学报, 1984, **11**, 181.
- [4] Redgrave, T.G. et al. Separation of plasma lipoproteins by density-gradient ultracentrifugation. *Analytical Biochem.*, 1975, **65**, 42.
- [5] Shepherd, J. et al. Radioiodination of human low density lipoprotein: A comparison of four methods. *Clin. Chim. Acta*, 1976, **66**, 97.
- [6] Nakai, T. et al. Rat high density lipoprotein subfraction (HDL₃) uptake and catabolism by isolated rat liver parenchymal cells. *J. Biol. Chem.* 1976, **251**, 4914.
- [7] 张滋等: 一种简易的大鼠离体肝脏灌注装置. 生物化学与生物物理学报, 1982, **14**, 567.
- [8] Dieplinger, H. et al. The determination of lecithin: Cholesterol acyltransferase in the clinical laboratory: A modified enzymatic procedure. *Clin. Chim. Acta*, 1980, **106**, 319.
- [9] 张滋等: 某些药物对大鼠血浆和肝脏脂蛋白脂酶活性及血浆胆固醇的影响. 药学报, 1983, **18**, 468.

- [10] Notelovitz, M. et al. Lipids and lipoproteins in women after oophorectomy and the response to oestrogen therapy. *British J. Obstet. Gynaecol.*, 1983, **90**, 171.
- [11] Mahley, R. W. et al. Two independent lipoprotein receptors on hepatic membrane of dog, swine and man. *J. Clin. Invest.*, 1981, **68**, 1197.
- [12] Yu-sheng Chao et al. Hepatic catabolism of rat and human lipoproteins in rats treated with 17- α -ethinyl estradiol. *J. Biol. Chem.*, 1979, **254**, 11360.
- [13] Hak-Loong Kim et al. Altered apolipoproteins in sex steroid-treated rats. *Metabolism*, 1978, **27**, 571.
- [14] Tikkanen, M. J. et al. HDL₂ and hepatic lipase: Reciprocal changes produced by estrogen and norgestrol. *J. Clin. Endocrinol. Metab.*, 1982, **54**, 1113.

9717

CSO: 4009/1094

INSULIN RECEPTOR CHANGES DURING RETICULOCYTE MATURATION IN CULTURE

Beijing SHENGWUHUAXUE YU SHENGWUWULI JINZHAN [BIOCHEMISTRY AND BIOPHYSICS]
in Chinese Vol 18 No 3, May 86 pp 258-262

[English abstract of article by Zhu Shangquan [2612 1424 2938] of Shanghai Institute of Biochemistry, Chinese Academy of Sciences, Shanghai; Ruth Wu Jin-shyun, Heather E. Fincham and James D. Young of the Department of Biochemistry, Faculty of Medicine, Chinese University of Hong Kong]

[Text] Reticulocytes harvested from guinea pigs made anemic by plebotomy were cultured in vitro to study insulin receptor changes occurring during reticulocyte maturation. The initial reticulocyte count at the start of culture was 50 percent as judged by staining with Brilliant Cresyl Blue. This value decreased progressively during the first three days of culture, until by day four no reticulocytes were present. The total cell count decreased by 10 percent during this period and reticulocyte maturation was associated with a parallel decrease (60 percent) in insulin binding capacity. However, after eight days in culture, the insulin binding capacity of the cells was still five-fold higher than that of mature red cells obtained from normal guinea pigs. (Paper received 22 Mar 85.)

REFERENCES

- [1] Gambhir, K. K. et al. Decreased erythrocyte insulin receptor binding in diabetic man with chronic renal failure. *Horm. Meta. Res.*, 1980, **12**, 414.
- [2] Robinson, T. J. et al. Erythrocytes: A new cell type for the evaluation of insulin receptor defects in diabetes humans. *Science*, 1979 **205**, 200.
- [3] Pederson, O. et al. Increased insulin receptors after exercise in patients with insulin-dependent diabetes mellitus. *New Engl. J. Med.*, 1980, **302** 886.
- [4] Helena, V. R. et al. Increased insulin binding to erythrocytes in anorexia nervosa. *New Engl. J. Med.*, 1979, **300**, 882.
- [5] Dons, K. F. et al. The insulin receptor is an age-dependent integral component of the human erythrocyte membrane. *J. Biol. Chem.*, 1981, **256**, 2982.
- [6] Thomopoulos, P. et al. Loss of insulin receptors on maturation of reticulocytes. *Biochem. Biophys. Res. Comm.*, 1978, **85**, 1460.
- [7] 彭兴华等: 单组份猪胰岛素的制备及性质. *生物化学与生物物理进展*, 1983(3), 690.
- [8] Roth, J. Methods for assessing immunologic and biologic properties of iodinated peptide hormones. *Methods in Enzymol.*, 1975, **37**, 223.
- [9] Gambhir, K. K. et al. Insulin radioreceptor assay for human erythrocytes. *Clin. Chem.*, 1977, **23**, 1590.
- [10] Thomopoulos, P. et al. Insulin receptors and protein synthesis in bone marrow cells and reticulocytes. *Diabetes*, 1980, **29**, 820.

9717

CSO: 4009/1094

INSULIN RECEPTORS ON RETICULOCYTE MEMBRANES

Beijing SHENGWUHUAXUE YU SHENGWUWULI JINZHAN [BIOCHEMISTRY AND BIOPHYSICS]
in Chinese Vol 19 No 3, May 86 pp 263-268

[English abstract of article by Zhu Shangquan [2612 1424 2938] of Shanghai Institute of Biochemistry, Chinese Academy of Sciences; Ruth Wu Jin-shyun and James D. Young of the Department of Biochemistry, Faculty of Medicine, Chinese University of Hong Kong]

[Text] This report describes an investigation of the concentration dependence and specificity of insulin binding to guinea pig reticulocyte and erythrocyte membranes. The properties of the guinea pig reticulocyte and erythrocyte insulin receptors are compared further by investigation of the effects of lectins, dimethyl sulphoxide (DMSO), N-ethylmaleimide (NEM) and dithiothreitol (DTT) on insulin binding capacity in the two cell types. (Paper received 28 Mar 85.)

REFERENCES

- [1] 彭兴华等: 单组份猪胰岛素的制备及性质. 生物化学与生物物理进展, 1983(3), 690.
- [2] Roth, J. Methods for assessing immunologic and biologic properties of iodinated peptide hormones. *Methods in Enzymol.*, 1975, **37**, 223.
- [3] Lowry, O. H. et al. Protein measurement with the Folin phenol reagent. *J. Biol. Chem.*, 1951, **193**, 265.
- [4] Cuatrecasas, P. and Tell, G. P. E. Insulin-like activity of concanavalin A and wheat germ agglutinin—direct interactions with insulin receptors. *Proc. Natl. Acad. Sci. U. S. A.*, 1973, **70**, 485.
- [5] Hedo, A. et al. Binding of insulin receptors to lectins; Evidence for common carbohydrate determinants on several membrane receptors. *Biochem.*, 1981, **20**, 3385.
- [6] Obberghen, E. Van. et al. Inhibition of insulin receptor binding by dimethyl sulfoxide. *Biochem. Biophys. Acta*, 1979, **582**, 486.
- [7] Schweitzer, J. B. et al. Difference in organization structure of insulin receptor on rat adipocyte and liver plasma membrane: Role of disulfide bonds. *Proc. Natl. Acad. Sci. U. S. A.*, 1980, **77**, 4692.
- [8] Jacobs, S. and Cuatrecasas, P. Disulfide reduction converts the insulin receptor of human placenta to a low affinity form. *J. Clin. Invest.*, 1980, **66**, 1424.
- [9] Massague, J. et al. Electrophoretic resolution of three major insulin receptor structure with unique subunit stoichiometries. *Proc. Natl. Acad. Sci. U. S. A.*, 1980, **77**, 7137.
- [10] Olefsky, J. M. and Chang, H. Further evidence for functional heterogeneity of adipocyte insulin receptors. *Endocrinology*, 1979, **104**, 462.

9717

CSO: 4009/1094

CHEMICAL MODIFICATION OF SUPEROXIDE DISMUTASE AND PROPERTIES OF MODIFIED ENZYME

Beijing SHENGWUHUAXUE YU SHENGWUWULI JINZHAN [BIOCHEMISTRY AND BIOPHYSICS]
in Chinese Vol 18 No 3, May 86 pp 309-311

[English abstract of article by Wu Yun [0702 0061], et al., of East China
Institute of Chemical Technology, Shanghai]

[Text] A method for the chemical modification of superoxide dismutase is reported. It involves the formation of a reactive intermediate by reacting dextran with sodium periodate and coupling the intermediate with SOD.

The modified SOD thus prepared retains 81 percent of native SOD activity. Dextran-SOD shows greater resistance to pepsin degradation, enhanced heat and pH changes. (Paper received 17 Jul 85.)

REFERENCES

- [1] 李益新等: 铜锌超氧化物歧化酶的重组研究. 生物化学与生物物理学报, 1984, 16, 472,
- [2] McCord, J. et al. Superoxide dismutase. *J. Biol. Chem.*, 1969, 244(23), 6049.
- [3] 袁勤生等: 牛血清铜锌超氧化物歧化酶的提纯. 医药工业, 1983, 4, 4.
- [4] 季文杰等: 超氧化物歧化酶活性快速测定的新方法——极谱氧电极法. 生物化学与生物物理学报, 1986, 18, 185.
- [5] 赵伯龙等: 右旋糖酐二醛的制备. 华东化工学院学报, 待发表.

9717

CSO: 4009/1094

TECHNICAL TRANSFORMATION OF IRON MINES

Maanshan JISHU KUANGSHAN [METALLIC MINES] in Chinese No 11, 20 Nov 86 pp 2-6

[Article by Wang Shaoliang [3769 4801 5328] and Fan Yongwen [5672 0737 2429], Ministry of Metallurgy Mines Company: "Seventh 5-Year Plan Technical Transformation Direction for China's Iron Mines"]

[Text] I. The Situation and Present State of Mines

Currently, the situation in iron and steel industry production is very good. In 1985, it comprehensively overfulfilled the plan, with steel output at more than 46 million tons, pig iron at more than 43 million tons, rolled steel at 36.9 million tons. The entire industry realized a profit of 13.5 billion yuan, greater than the increase in the value of production. There was an industrywide improvement in economic results, the quality of production was further improved, the variety of products increased, and the consumption of energy and other raw materials declined. The high-speed advance of steel output in the last 3 years of the Sixth 5-Year Plan, a net annual increase of over 3 million tons, has advanced by 2 years the realization of the planned targets of the Sixth 5-Year Plan. This year we enter the first year of the Seventh 5-Year Plan and steel output may break 50 million tons.

The situation in iron ore production is also very good. Output moved up the completion of the Sixth 5-Year Plan by 1 year. The position of magnetic iron ore concentrates has held at over 66 percent, reaching advanced international levels. In 1985, iron ore production was more than 130 million tons; iron ore concentrate was more than 43 million tons, also overfilling the state plan.

Compared to iron and steel production there is a very big gap in mine production and it has always been in a backward and passive position so that ore output is far from satisfying the demands of iron and steel production. Mines are a very weak link in the iron and steel industry.

For a long time China's mining equipment manufacturing technology has been in a backward state: openeast mines make up 90 percent of gross output of iron ore but we still have only 4.6 and 1 cubic meter power shovels, the overwhelming majority of trucks are 30 tons and below and, more important, they are trucks imported from abroad, the railway dump cars used on the stope are

only 60 tons, the largest electric cars are 150 tons, and the only Chinese-manufactured equipment to be widely used is the gear drill and the (qiankong) drill. At the end of the Sixth 5-Year Plan, cooperative manufacture abroad and some imported advanced modernized equipment was installed in one or two mines but the level of production technology is still far below the level of advanced mines abroad.

For opencast mines, there are few models of primary equipment, they are not in series, but that the auxiliary equipment is not in complete sets is even more noticeable. In modern mechanized mines a great many procedures still must be carried out by primitive manual methods, which has a profound impact on exploiting the efficiency of the primary machinery. That the roadbuilding equipment for opencast mines is incomplete is an obvious example.

Underground mine equipment is even more backward. The rock drilling platform vehicle has not been promoted for a long time but pneumatic support rock drills are generally used to drill blast holes, hydraulic rock drills are still in the testing stage; fifties vintage pneumatic T4G loaders from abroad are still used for loading, some special-use equipment which is suited for specially designated mining methods, such as the (Qiaomaoji) are still lacking; the level of auxiliary occupation mechanization is still very deficient, and also not in complete sets and not in series, and many tasks still must be done by cumbersome and unsafe physical labor. The electromechanical- and diesel-powered scrapers imported from abroad in the last years of the Sixth 5-Year Plan are still in the testing stage.

Opencast mining is still primarily the traditional fifties technology of a slow work edge moving toward reliance on fixed-edge excavation of long trenches, particularly mine use of truck transport. Although trucks are flexible they cannot escape the restrictions of old traditions to create a higher stripping ratio than earlier production, construction time is long, economic results are poor, and there are now only a few medium-scale opencast mines test using a steep working edge and extraction by stages. Interrupted-continuous technology is still in the trial stage.

The basically low-efficiency, low-recovery mining methods now in prolonged use in underground mines, not to mention the condition of the ore bed, and the rigid use of certain mining methods that have seen their day, has created a situation in which some mines which have recently gone into production cannot produce up to standards and in which there are serious losses economically.

Mine management still uses traditional handicraft industry methods to manage modernized mines. The use of such advanced theories as systems engineering and such advanced techniques as computers for scientific management is currently in the beginning stage.

Although China has several tens of billion tons of iron ore resources, the overwhelming majority are lean ores, with the iron-bearing grade only about 32 percent and for such ores which are difficult to select as magnetic hematite mix, in which there are numerous accompanying comprehensive ores and the embedded grains are fine, there are still some suitable reserves but

due to such conditions as hydrology, communications, and technology they cannot be utilized in the near term. Especially large-scale iron mines such as in the Soviet Union, United States, Canada, Australia, and Brazil have not yet been discovered in China.

Due to the above factors, the maximum designed scale of China's opencast mines is 10 million tons, but the actual capacity is 8 million tons; the maximum designed scale of the underground mines is 5 million tons, but the actual capacity is 3 million tons, three- to fourfold lower than large-scale iron mines abroad.

In short, the production technology and economic situation of China's iron mines is still at a very low level and this creates an enormous task for the technological reform of iron mines in the Seventh 5-Year Plan.

II. Iron Mines' Seventh 5-Year Plan and Struggle Goals for the Year 2000

The output of iron mines in 1990 will be 150 to 160 million tons and by the year 2000 it is estimated to reach 260 million tons.

From the current level of iron ore production to the 260 million tons to be produced in the year 2000 is nearly double, that is an average annual net increase of iron ore output of 8 to 9 million tons. This will have to be resolved by reliance on two aspects: one is to have a slight increase through technological transformation of existing mines, on the basis of making up the natural elimination and decline of capacity; the other is to count on capital construction of mines to pick up the burden. In the past, the mine construction period was long, results were poor, and they were slow to go into production. This is not an inherent law of mines, but is due to the unreasonableness of some policies. The system is a large problem and these problems are now being resolved. I believe that the other problems will also be resolved one by one.

III. Iron Mines' Seventh 5-Year Plan Technological Transformation Plans and Development Trends

The guiding thinking is to adhere to the principle of fine materials, focusing on improving the economic results and comprehensive production capacity of mines, rely on modern scientific management and technological progress to improve the educational level and living conditions of mine employees' families, improve employee material benefits, and change mine enterprises from purely production to production, management, and development enterprises.

For production mines, during the Seventh 5-Year Plan, we propose four goals:

A. Product Output

Strive for iron ore output in 1990 of 150 to 160 million tons, an increase of more than 30 million tons over 1985.

B. Product Quality

The grade of iron ore concentrate: magnetic ores should maintain an iron content above 66 percent; red iron ore concentrate, for ordinary Anshan type hematite ore the iron content should reach more than 63 to 65 percent, an improvement of 2 to 4 percent over the present, the metal recovery rate should be over 75 percent, basically achieving advanced international levels.

C. Economic Results

Total profits and taxes of independent mines in the Seventh 5-Year Plan should, compared with the same specifications, increase annually 6 to 10 percent.

D. Improve Income of Mine Employees, Improve Education and Living Conditions of the Mine Area, Build Mine Area Into a New Civilized Town

The following tasks should be carried out to realize these goals:

1. Formulate rational mine policy to mobilize the initiative of all parties and invigorate the mines.

a) The most important thing is pricing policy. Improving iron ore pricing encounters two obstructions.

One is competition with imported iron ore. China's policy of using both domestic and foreign iron ore resources is correct. Foreign iron ore resources are good and with the current depression in the iron and steel industry abroad, ore prices are low. For a long time the international buyer's market in ore will not change and this is favorable for our use of foreign ore to expand the iron and steel industry. Using two sources should first of all fully exploit the capacity of domestic mine production and where this is inadequate it should be supplemented with imported ore. However, current pricing policy does not favor expansion of domestic mine production. There are three reasons for this: the domestic price of imported ore is calculated according to foreign exchange prices and this is unreasonable. It should be higher than the market exchange rate; 80 percent of the difference with domestic price is subsidized by the state with the enterprise paying only 20 percent, in addition the quality of imported ore is stable, and there are also shipping guarantees all of which creates conditions superior to those of domestic ore; internationally, ore resources are good, costs are low, the relative price is inexpensive, it is difficult to resolve the problem of perception if the price of domestic ore is raised above the price of imported ore (as calculated according to the foreign exchange rate) and this has restricted raising the price of ore to rational levels. Thus, in the problem of regulating prices in the reform, whether or not iron ore prices can be raised to rational levels will have an impact on imported ore.

Second is that within the metallurgy industry historically iron ore prices have been too low and the obstacle this presents is very large.

On a national scope, the rate of profit on funds of the metallurgy industry is lower than the average level of the rate of profit of industrial funds.

In the metallurgy industry in 1982, for example, the metallurgy industry's rate of profit on funds was 13 percent, but 23 independent mines averaged 2.19 percent. Although iron ore prices were readjusted in 1984, they are still too low, and the rate of profit on funds is only 6.8 percent, the ideological obstacles to the rate of funds of mines exceeding the fixed prices of processing plants are considerable, but mines should be higher than processing plants.

b) Iron mines generally are far from cities, with some locations in out-of-the-way mountainous and frigid areas, the intensity of mine labor is considerable, working conditions are dangerous and adverse, it lacks the amenities of life, it is difficult for children to attend school and find work, and the remuneration for mine employees is lower than in the cities and lower than in processing enterprises. Therefore, we should draw up some appropriate mine policies to improve the remuneration of mine employees so that they are content to work in the mines. Recently, the state decided to implement a per-ton wage contract in the mines, for example, while guaranteeing normal excavation, annual growth in profits and taxes, and annual increases in output, the Taigangekou Iron Mine and the Jiugangjing Iron Mine, implemented the per-ton wage contract, put no lid on bonuses, and after linking up with enterprise economic results there was a great change in the mine.

At the same time, we advocate that mines improve their own mine areas, implementing the principle of one industry being primary and diversifying, such as the Hainan Iron Mine using the subtropical climatic conditions to cultivate rubber and bringing in specialists to build a rubber manufacturing plant; or the restaurants built in Guangzhou and Zhuhai which developed a tertiary industry and found employment for sons and daughters. The Capital Steel Co built a chick-processing factory and a livestock-processing factory to improve the lives of employees.

2. Modernize mine management. Without management modernization, there will be no modernization of industrial processing and equipment; with advanced technology and equipment but without scientific management, the advanced technology and equipment will be unable to exercise the efficiency it should.

a) Modernizing management thinking is the precursor to promoting modernization of mine enterprise management: The influence of old thinking and old concepts of the past must be eliminated, and new management thinking and principles established and conservative, handicraft industry-type traditional old management methods replaced by new modernized management methods.

b) Modernization of the management organization is an organizational guarantee of implementing modernized management: On the basis of the current situation in mine administration and management, the most important thing in improving the mine management system to suit the needs of mine production growth is to establish an organizational structure that is adapted to the needs of management modernization. On the basis of the characteristics of mine enterprises, in line with the principle of retrenching and expanding rights and combining the concentration of management and responsibility by levels we should reform the old management system and organizational form and, as

appropriate, divide it up into small accounting units, strengthen organizational structures in such areas as administrative policymaking, technological development, marketing service, information feedback, and personnel training.

c) Modernization of management methods is the key to implementing enterprise modernization: The dozen modernized management methods recommended by the State Economic Commission should be organically combined according to their inherent connections and actual needs and systematically promoted, especially with attention to combining closely the several items of "comprehensive management" which have been promoted and definitely been effective in mines in the past few years with some individual items of modernized management methods, so that they gradually become systematized and regularized. For example, in the area of plan management, implementing comprehensive plan management, promoting and applying management by objective, input-output analysis improving, devising strategies, policymaking technology, market surveys and forecasting, rolling plans, linear plans, and network technology in order to find the optimum production administration plan and engage in plan formulation and plan control; in the financial management area, implement comprehensive economic accounting, promote value engineering, engage in cost control and profit forecasting; in the area of quality management, promote comprehensive quality control, broadly apply it in all systems of production administration; in the area of equipment management, implement a comprehensive equipment management system, promote and apply value engineering, implement selection of the best materials for purchase, quota control, and quantitative supply.

d) Modernization of management techniques: Widespread adoption of the computer is an important technique for implementing management modernization and is also an important indication of implementing mine enterprise management modernization. In addition to the necessary disposition of advanced monitoring and measuring devices and instruments, using computers also requires the possession of the corresponding basic work and management operators and this reflects the level of enterprise management modernization.

e) Modernization of management talent: Not only should we improve the professional quality of mine enterprise leaders, but through training of all personnel improve the technological and professional quality of management personnel.

3. Rely on S & I advances to accelerate the technical transformation of mines. Using new technology, new processes and new equipment to transform existing mines is the key to economic results of mines, stabilizing and improving the output of mines, and improving mines and ore concentrate quality.

a) During the Seventh 5-Year Plan, ore-dressing plants will primarily improve the quality of hematite ore concentrate through technological offensives and through technological transformation of old dressing plants to improve the processing capacity of the ore-dressing plants and save on energy.

Through the technological offensives of the Fifth and Sixth 5-year plans, the iron-bearing grade of China's magnetite stabilized at over 65 percent, while key mines throughout the country averaged 66.3 to 66.8 percent, achieving international ore standards. However, for many years the hematite ore

concentrate product has hovered between 57 percent and 62 percent. The task of the Seventh 5-Year Plan is to raise the iron concentrate product grade of dressed red iron ore to more than 63 to 65 percent (general Anshan-type hematite ore) and basically reach international ore standards.

The transformation of old ore-dressing plants primarily centers on reducing the size of ore entering the grinder, improving grading efficiency of ground ore, transforming processing flow; dressing plants with the conditions should adopt grinding and dressing by stages, improve the tailings transport concentration, and adopt such measures as large-scale, high-efficiency ore-dressing equipment so that dressing plant capacity is increased to more than 20 to 30 percent, and economize greatly on energy sources.

b) Perfect and improve the level of mine technology and equipment. The key points of Seventh 5-Year Plan work focused on China's current situation in which mine equipment efficacy is poor, it is not in complete sets and not serialized. These points are:

First, rapidly master, digest, and transplant equipment which is imported and manufactured with foreign cooperation, promote 30-, 50-, 100-, and 150-ton mine trucks manufactured with foreign cooperation, auxiliary operations equipment sets, such as those for roadbuilding and powder charges, and such equipment as ore scrapers used in underground mines; place key stress on mechanized sets at the Bengang Nanfen large-scale opencast mine and Jiugangjing Tieshan large-scale underground mine to make these two mines rapidly reach the level of production technology and management of similar scale mines abroad in order to spur on other mines.

Second, auxiliary equipment which is not in complete sets is a prominent contradiction which should be resolved by the Seventh 5-Year Plan. On the foundation of existing equipment, carry out linking up the parts to form a whole so that individual working process equipment will correspond and form an integral, comprehensive production capability in order to capitalize on the efficiency of the primary equipment.

Openpit mines should resolve in an emphatic way roadbuilding mechanization, powder charge and equipment safeguard inspection, and repair mechanization, technological materials supply, communications and command modernization. Underground mines should resolve the mechanical equipment required for better, high-efficiency, and individual work processes, and achieve overall mechanization. To take care of complete sets of equipment, a combination of imported technology and domestic manufacture should be adopted. For the past few years, the mechanization campaign of the Fushan underground iron mine of the Hanxing Mine Bureau has achieved some preliminary results, and through a period of production practice this year has not yet made comprehensive inspection and appraisal, but has summarized underground mechanization work and will make further plans.

Third, perfect mine equipment serialization, and provision of sets in a planned and systematic way to draw close to advanced international levels. China's existing mine equipment, both primary and auxiliary, is extremely

poor in terms of varieties, models, and standards and this should be resolved with the support of China's mine equipment research and manufacturing departments. This task can only be realized after several 5-year plans.

Power shovels which are the loading equipment for openpit mines should be in 1-, 2-, 4.6-, 7-, 10-, and 15-cubic meter grades; trucks should be in 8-, 20-, 50-, 100-, and 150-ton grades, railroad transport should be by 60- and 100-ton dump cars and 100- and 150-ton electric locomotives and long-arm power shovels; drilling equipment should have gear drills with hole diameters of 250, 310, and 380 mm and long-cantilever bulldozers; deep opencast mines should have movable or semimovable crushers, fixed and movable steel cable belt machines and sets of equipment, and railroads' 240- and 360-ton dragger groups.

During the Seventh 5-Year Plan more open cast mines will get into deep extraction, and where a single railroad and truck transport is economically unreasonable, conveyor belt transport is almost the only recourse, but the development of conveyor belt transport and its associated equipment and automatic control instruments is still very backward in China and it should try hard to catch up.

Such auxiliary equipment as frontend loaders and auxiliary power shovels are useful for improving loading efficiency; multifunction power charge trucks can mix and pack prills and oil, and emulsion explosives, reduce ground facilities for producing explosives, and improve the quality and efficiency of packing charges. High-power bulldozers, graders, movable crushers for road building, refueling trucks, water trucks, service cranes, ambulances, command trucks, tire-changing machines, wheel-changing machines, (yidaoji) suited to railroad transport, ballasted tamping machines and snow-removal machines are important auxiliary equipment.

Underground mines should stress development of trackless shovel-moving machine series as primary equipment, today both diesel power and electric power are important. Correspondingly develop openpit (pafou) tunneling, mining hydraulic platform vehicles and hydraulic rock drilling tools, and power charge, (penmao) materials shipping, inspection and repair, and fuel supply equipment; and should also develop suitable (giaomaji) for pillaring, high-pressure qiankong drills for making deep holes, combined tunneling machines for tunneling; at the same time complete and auxiliary ventilation fans suited to use in underground conditions should be developed.

c) Vigorously advance excavation disposition and extraction methods: That excavation disposition is irrational and extraction methods are not appropriate are among the important reasons why the mine-construction cycle is long, it is slow to reach production, and economic results are poor.

In openpit extraction processes, under burial conditions of certain ore beds, using the steep workface angle, adjusting the extraction procedure, postponing the time of stripping flood peak, can bring clear economic benefits to open cast mine production and construction. Recently, the Anshan Ferrous Metallurgy Mine Design Institute did a feasibility study of deep, steep

face extraction at the Nanfen openpit mine and compared with slow face extraction, the production stripping ratio dropped from the original 5.4 ton/ton to 4.8 ton/ton, the earlier stripping flood peak period steep face extraction stripped 15 million fewer tons of rock per year than the slow face extraction, the volume of slow extracted rock for the entire period was 180 million tons, and the investment in the earlier period of steep face extraction was 120 million yuan less than with slow face extraction. There are many design and production examples of schemes different from the Nanfen Mine which obtained different results, such as the Sijaying, Dumushan, and Taihe iron mines.

Transportation to China's openpit mines is clearly a weak link and transformation of mine technology clearly is resolution of the transportation problem. Truck transport is the developmental direction, but China's heavy truck manufacturing industry is unusually weak and we have accumulated much experience over a long time in using truck transportation, thus in selecting a transport method we should suit mining conditions, for example, some openpit mines are already using railway transport, and in deep mines where it is not appropriate, we should actively adopt a combined transport of railways and trucks. In deep openpit mines in particular we should promote interrupted-continuous processing (trucks or railways--mobile crushers--steel core conveyor belt transport). According to information on this process used in mines in the Soviet Union, it improved labor productivity 80 to 100 percent, lowered extraction costs 10 to 12 percent, reduced the number of trucks needed by one-half to two-thirds. China's Dahushan iron mine is currently building such a system, and should accelerate the work to absorb experience and promote it. Railway transport should promote Soviet hauling engines, improve hauling and climbing capability, and prolong the life of railway transport. For earth disposal we should stress constructing rubber conveyor belt earth-disposal systems at Donganshan and Shirengou, improve earth-disposal capability, reduce the area of land occupied and promote it.

In underground extraction, China's underground iron mining still uses the pillarless partition caving method and should continue to improve this mining method, selecting high-efficiency, trackless equipment suited to this mining method; enlarge stage height and reduce the volume of tunneling; use instruments which rapidly determine ore grade in order to guide scientific ore release and improve ore recovery rates; improve ventilation systems to create good work environment. The construction cycle of new underground mines which have gone into production at the end of the Sixth 5-Year Plan, such as the Xishimen and Xiaoguanzhuang iron mines are above the levels of the fifties, but the equipment and processes selected at the time are already out-of-date. The mining methods selected for thick ore bodies which belong to slow slopes and compound ore bodies in which the rock is unstable are not well suited and on the evidence of specialists, using such mining methods as a variety of stage caving methods and gallery and pillar methods should be used to improve the economic results and production capacity of mine extraction and organize a campaign of scientific research academies and institutes and institutions of higher learning with these mines to turn losses into gains as quickly as possible.

d) Implement cultural production with attention to environmental protection, improving working conditions and living environment. Working conditions in China's underground mines are currently abominable: ventilation is poor, dust concentrations are high, harmful gasses are increasing, there is much water and mud on work surfaces and in tunnels, they are both dirty and chaotic and the Seventh 5-Year Plan should devote a great deal of energy to changing these situations. In addition to strengthening management, transformation of ventilation systems should be stressed first of all. The old ventilation systems bring air in through auxiliary shafts and expel it through two wing air shafts. The system is too large, the ventilation machinery capacity is large and uses much electricity. The two paths are complex, leak air everywhere, and the net result is poor. A multilevel, machine-station ventilation method has been tested in the Meishan iron mine, changing a large system into a small system with an effective ventilation rate of more than 70 percent. In the Seventh 5-Year Plan, it should be comprehensively promoted in underground mines. Stress on developing equipment and measures to remove and reduce dust should be continued so that the rate of compliance with dust standards reaches 90 percent.

Concave pit openpit mines should continue to study ventilation and dust removal measures, first of all wetting down roads, sealing truck, power shovel, and punch operator cabins, installing air regulators, especially insuring that in the extremely hot summer climate, workers have good working conditions.

4. Develop local mines. In recent years in line with the spirit of directives from leadership comrades of the Central Committee fostering leadership of local mines, output has risen year by year. In 1983, the iron ore output of medium and small local mines was 30.22 million tons; in 1984, 37.25 million tons; in 1985, 46.74 million tons, and as long as policy is on the right track, the potential of local mines is great. In the 18 years from 1965 when the mine in Wuan County, Hebei, operated by disaster relief began until 1984 the local investment was 16 million yuan and state investment was 4 million yuan. There are 8 x9an-operated mines, 32 commune operated mines, 5 medium- and small-scale dressing plants with fixed assets of over 20 million yuan, forming a capacity of annual output of 1 million tons of ore, 400,000 tons of ore concentrate, and 100,000 tons of enriched powdered ore. The gross value of production for the 18 years is 300 million yuan; profit is 180 million yuan, 72 million yuan has been handed over to the state and 6,000 have been employed. After the Central Committee proposed "opening up to small mines," in over a year's time, the output of this county jumped to 20 million tons per year, and the Seventh 5-Year Plan's planned growth is to 25 million tons per year. Tangshanshi in the more than 1 year from the fourth quarter of 1984 until the end of 1985 reached an annual output capacity of ore concentrate of 10 million tons, and is now improving and forming a complete set. The Central Committee has now decided each year to give medium and small local iron mines 50 million yuan in low-interest loans to develop local mines. In the future, we also suggest implementing more favorable economic policies with regard to local mines to encourage them to raise funds locally for operating mines.

5. Make the environment green, improve mine area construction, expand culture and education in the mine area, improve commercial networks in the mine area, make the market flourish, and create good living conditions to make mine areas into new modernized cities.

6. Improve the mine management system. Most of China's key iron mines are under the jurisdiction of joint enterprises, but these are two different enterprises and managing mines with the methods for managing plants seriously restricts the growth of mine enterprises. The Soviet Union has 52 mine enterprises, of which 32 are independent mines; apart from U.S. Steel, all U.S. mines are independent enterprises. China's mine-management system should be reformed.

8226/12828
CSO: 4008/2092

PROGRESS IN REMOTE-SENSING TECHNOLOGY

Beijing XIANDAIHUA [MODERNIZATION] in Chinese No 1, Jan 87 pp 6-7

[Article by Yang Shiren [2799 0013 0088], Institute of Remote-Sensing Applications, Chinese Academy of Sciences: "Progress in China's Remote-Sensing Technology and Applications"]

[Text] During the process of China's implementation of our four modernizations, it is extremely important to bring science into the surveys of natural resources, environmental protection, and planning and policymaking. These requirements have resulted in extraordinary growth for applications of remote-sensing technologies. The Chinese Academy of Sciences and sectors in agriculture, forestry, water conservancy, mapping, geology, space flight, nuclear industries, railways, and meteorology, as well as all relevant higher institutions, have all established institutes, centers, ground reception stations, and the like for remote sensing and its applications. Some provinces and cities have established regional research centers for remote-sensing applications, also setting up many specialized companies having service in remote-sensing technology as their goal. Numerous specialists are currently actively engaged in the research and development of remote-sensing technologies and their applications, in which they have made much progress.

The Aquisition and Processing of Remote-Sensing Materials

Since operation of China's LANDSAT ground station this last summer [1986] for the aquisition of space remote-sensing materials, we have been able to gather and distribute data from multiple-spectrum scanners and special mapping imaging from the American LANDSAT, and we have been able to better receive data from the French SPOT satellite. Through the channels of international exchange, sources such as the American space shuttle and side-looking imaging radar and the French SPOT satellite images have been used in certain research efforts. Meteorological sectors in China have long received NOAA/TIROSN images. In addition to meteorological applications, these have also been disseminated to nonmeteorological applications. The land satellite series launched by the Ministry of Astronautics has successfully received various remote-sensing images, and is currently engaged in developing remote-sensing satellites having periodic real time transmission capabilities.

Regarding space remote sensing, China has imported more than 10 remote-sensing aircraft that work at 10,000 meters and above. They are equipped with instruments such as high-resolution aerial photographic equipment, multi-spectrum scanners, and side-looking radar. In addition, we also have dozens of medium-altitude remote-sensing aircraft. Organizations such as the CAAC Special Aviation Co and the China Aerial Remote-Sensing Service Co have developed commercial services for aerial remote sensing.

Remote-sensing transducers that we have developed in China include multi-spectrum cameras, multispectrum scanners, and multiband infrared scanners. CCD devices, cameras, microwave radiometers for various bands, scanning microwave radiometers, actual-aperture and synthetic-aperture side-looking radar, and imaging spectroscopic instruments have been used in various test applications that will develop into application systems.

In analytical processing of remote-sensing image data, computer image-processing techniques have also achieved wide application.

Applications of Remote Sensing in Land Resource Surveys

Land resource surveys are extremely important for formulating economic growth planning in China. The Materials Bureau of the National Remote-Sensing Center once organized relevant units around the use of images for the measurement of the usable land in the territory of all the provinces in this country and of 15 land categories, which provided more complete and reliable data regarding China's land-use situation. In 1985, the Institute of Remote Sensing of the Chinese Academy of Sciences took on the responsibility for surveys of the land-use situation in the Xizang Autonomous Region. The area of the Xizang Autonomous Region is 1.22 million sq km, a population of 1.8 million, and an average height above sea level of 4,500 meters. In an area having this complex a terrain and sparse population, it is very difficult to use normal methods to do land-resource surveys.

The Institute of Xinjiang Geography of the Chinese Academy of Sciences organized relevant units to do aerial remote-sensing surveys of the drainage area of the Tarim He in order to understand the land-use situation for that region. This is of major significance in developing the agricultural and animal husbandry industries and for afforestation.

From 1983 through 1985, the Changchun Institute of Geography of the Chinese Academy of Sciences did a resources remote-sensing reexamination of 108,900 sq km of the Sanjiang Plain, in which they accomplished specialized mapping of land use, land resources, grasslands, and vegetation. In comparison with regular methods, two-thirds of the time and manpower was saved. The results of the reexamination showed that there has been an increase in cultivated land of 21 percent over that indicated by previous data and that marshlands are only 46 percent of those in previous data.

Applications of Remote Sensing in Urban Environmental Monitoring

With the growth of economic construction in China, urban environmental problems are becoming more and more important, and the Institute of Remote Sensing of the Chinese Academy of Sciences and the Tianjin Municipal Office of Environmental Protection organized relevant units in the use of various remote-sensing materials. They did a survey of the effects on the Tianjin municipal environment from water, atmospheric, and thermal pollution, as well as their effects on the ecological environment. They used computer-aided drafting systems to compile a set of charts on Tianjin Municipality environmental quality for use by Tianjin urban construction and environmental protection departments.

The Liaoning Environmental Remote-Sensing Center has used remote sensing and other test instruments for research on the rules for the dispersion and diffusion in three dimensional space of atmospheric pollution from urban industries and residential areas, as well as their relation to thermal conductivity effects in industrial cities, all of this for new diffusion models of atmospheric pollution.

In recent years, relevant departments in the cities of Beijing, Shanghai, Shenyang, Chongqing, and Luoyang have begun to use remote-sensing technology for environmental surveys and quality evaluations.

Applications of Remote Sensing in Agriculture

Remote sensing is being ever more broadly applied in agricultural sectors. Beginning in 1982, aerial photographs have been used to interpret charts of the soils of many districts.

In the "Chiang Jiang-Wei He-Ocean Floor Yielding Cropland Transformation" project organized by the Chinese Academy of Sciences, the Remote-Sensing Institute used aerial color infrared photographs of the Henan natural Wenyan Canal drainage area to make 29 kinds of special charts regarding things such as land forms, soil, land use, waterlogging analysis, and land classification for a 4,000 sq km area, which provided practical data for regional comprehensive management planning.

Agricultural sectors in this country have also systematically used remote-sensing methods in Hebei Province and Beijing Municipality for research into estimating crop yields. They have used LANDSAT images of 270 million mu of cultivated land within 300,000 sq km in 313 counties in the Huang-Wei drainage area for experiments regarding large-area crop assessments of wheat; they have done grassland-resource surveys of a 227,000 sq km area in Nei Monggol and Hebei; and progress has been made in infrared monitoring of wheat aphid destruction, as well as in studies of modeling for paddy rice crop assessments.

Applications of Remote Sensing in Forestry

Forestry departments in this country began to use aerial photographs for forest-resource surveys during the 1950's. In 1977, units such as the Academy of Surveying, Planning, and Design of the Ministry of Forestry used multi-spectrum scanner images and aerial photographs for a check of forestry resources in the Xizang Autonomous Region, from which they fundamentally clarified the area of forests in Xizang and the amount of livestock raising, and from which they drew up forest distribution charts for this area. In the Heilongjiang Jiangshanjiao forest and the Guangdong Nankunshan forest they have set up two forestry remote-sensing experimental sites in which to undertake various applications research in remote-sensing technologies. During the previous 5 years there was also the Fujian forested area that was an experimental site, and in which applications research done using remote-sensing technologies for forest resources dynamic monitoring resulted in 15 practical research achievements. Aerial side-looking radar imaging was also done in this experimental area for feasibility experimental research on forestry applications, and remote-sensing imaging was used for surveying slashing and burning, which also generated reliable results.

At the Sichuan Wang Lang Natural Conservation Area, the Chengdu Institute of Geography used the characteristics of spectral reflection to monitor bamboo of different growth periods and for predictions regarding the blooming time for the arrow bamboo that is the principal food for the giant panda. This has been extremely useful in the protection of this treasured wild animal.

Applications of Remote Sensing in Hydrography and Hydroelectricity

There is already widespread application of remote sensing in aspects of hydrography and hydroelectricity in China, and the departments of hydroelectricity alone have done hundreds of remote-sensing applications.

Remote-sensing materials have been effectively used in the monitoring of flood conditions and in estimating flood inundated area. During inundation by the Liao He in 1985, airborne radar was used for the side-looking radar imaging, reproduction, and mosaic of 11,000 sq km in the lower reaches of the Liao He within a period of 22 hours. NOAA satellite materials were used to monitor flood waters in Liaoning and Hefei areas that same year, and multiple-spectrum scanner imaging was used to estimate the area of inundation in the Sanjian Plain in 1981. This year, the Liao He has flooded several times, and once again color infrared photography was used to monitor the flooded areas and to analyze the reasons for the flooding.

Soil and water loss in China is serious, and using remote-sensing technologies to study types of soil erosion, to determine the sources of river loads, and to exercise control in order of seriousness and urgency are effective ways to save in land reclamation. Water conservancy departments in China are using remote-sensing imaging to divide the soil erosion situation in the areas above Guanting on the Yongding He, building water and soil conservation projects for management in areas of serious water and soil losses. This method has been quite useful for project planning and deployment, and has been fully

implemented around the seven major rivers in this country and at other continental river areas.

Survey of reservoir inundation damages is an important task for hydroelectric project construction. Hydroelectric departments have used remote-sensing methods at the Banqiao Reservoir to survey flood damage in the reservoir area. When compared to regular methods, there can be a savings in expenses of more than 1,000 yuan and more than 100 persons in manpower for each square kilometer. The Institute of Remote Sensing did flood damage surveys of two shoals in western Sichuan and of the Longtan Reservoir on the Hongshui He in northern Guangxi. The Chengdu Institute of Geography did flood-damage estimates of the Sanxia Reservoir on the Changjiang and an evaluation of the environment regarding the bearing capacity of the residents, which were provided to the planning department of the Sanxia project for reference.

In aspects of hydrography, remote-sensing technologies are effective means for clarifying spring sites, overflow regions for groundwater, concealed aquifer rifts, ancient river beds, and regions with brackish distribution. Remote-sensing technologies are also broadly used in studies of river mouths and ocean shores.

Applications for Geologic Remote Sensing

Geologic sectors in China have already had years of experience applying remote-sensing technologies. In formulating geologic surveys, the Ministry of Geology and Mineral Resources must use remote-sensing materials and must use composite analyses of data from remote sensing and from mineral mines.

Remote-sensing materials are also broadly used in the analyses of disaster geology and engineering geology. For example, they were used to analyze the distribution and contributing factors in the large-scale landslides at areas such as the Xintan on the Chang Jiang and Mt Sale in Gansu, the mud-rock flow distribution and predictions for the region around Beijing, and geologic structures in the Fuzhou economic zone. Analysis of remote-sensing materials from the Sanxia region of the Chang Jiang has shown that the stability of the dam regions that have been worked out is quite good and that there is no regional fault passing through, but that there are ancient landslides along the trunkline into the reservoir area and 33 cave-ins. This has been very useful in evaluating the stability of the banks of the reservoir. Remote-sensing technology provides the materials on geologic structural stability for major engineering projects. The Institute of Remote Sensing of the Chinese Academy of Sciences has used satellite and aerial remote-sensing materials to do regional geologic stability analyses and project environmental evaluations for many power stations in China, which has proved a reliable basis for the construction of power stations.

The Institute of Geology of the State Seismological Bureau used remote-sensing imaging to study the geologic structural background occurring in powerful earthquakes, which highlighted regions having a tendency toward the occurrence of earthquakes. They also compiled and published the "Set of Typical Satellite Striographs of Active Structures in China" materials, which has

provided useful materials for research into the contributing factors in earthquakes and for long-range predictions of earthquakes.

Railway departments in China use satellite and aerial remote-sensing imaging for managing existing lines and to find a scientific basis for route selection in building new railways. These materials have been accurate and reliable, and have saved time and manpower.

Applications of Remote Sensing in the Coal Mining Industry The Ministry of the Coal Industry Remote-Sensing Center used remote-sensing imaging to find the Wunite coal fields on the western slopes of Daxing'anling, they found coal-bearing basin boundaries and important structures for controlling coal fields, and they differentiated four two-level coal-bearing basins. Experience has shown that the coal seams are 40 meters thick. Coal reserves are 3.4 billion tons. They also used remote-sensing imaging to fill in five kinds of large-scale coalfield geological charts, which increased work efficiency threefold over regular methods and lowered the costs by two-thirds, and they also drew up four coalfield geological charts.

In 1984, the Kai-Luan coal mines and the Fangezhuang mine experienced an incident involving a large water burst in the pits, where water poured in at the rate of 2,070 cubic meters per minute, flooding the pits and resulting in damages amounting to hundreds of millions of yuan. By applying remote-sensing methods, they found that the primary channel for the inpouring water was an active fault at Wangxizhuang, which clarified the direction in which to regulate the water and to do flood control. In addition to these things, they also discovered burning areas and the scope of burning at the Shenmu coalfields in northern Shaanxi Province, which provided effective data for protecting resources from coal disasters.

Applications of Remote Sensing in Other Aspects

The Ministry of the Nuclear Industry Geologic Remote-Sensing Applications Center has applied various aerial and space remote-sensing materials in regions such as Yunnan, Jiangxi, Hunan, Hebei, Nei Monggol, and Gansu to analyze uranium mine geology and the conditions for opening uranium mines, and uranium mines have already been found from some of these.

China has long received and used weather satellite materials for weather analysis and forecasting. These have proved especially important for the Qinghai-Xizang Plateau and ocean areas, where normal weather materials have been rare; for example, using weather satellite materials for real time monitoring of typhoon occurrences, for estimates of food crop and grazing grass yields, and for predicting floods and fires.

Remote-sensing materials have also found widespread use in this country to study glacier snow accumulation and frozen soil, to find fishing grounds, and to improve fishing catches.

12586
CSO: 4008/2072

VALUE OF SPACE REMOTE SENSING EMPHASIZED

Beijing XIANDAIHUA [MODERNIZATION] in Chinese No 1, Jan 87 p 8

[Article by Wang Xiji [3769 1585 1323], Chairman of the Science and Technology Commission, China Institute of Space Technology: "Space Remote-Sensing Technology and Building of the National Economy"]

[Text] Population, natural resources, and the environment are major strategic decisionmaking problems for the growth of any nation's economy and for its territorial renovation, and they are also major items of increasing concern and study by the politicians and scientists of each country. The current population of the world is about 4.6 billion people, and by the year 2000 this is estimated to be at 6.3 billion. As populations increase and production levels improve, people will further increase the intensity with which they develop the natural world on which they depend to live, the quantities of natural resources in demand will increase, and there will be more and more demand for commodities. At present, many countries not only feel that their land resources are insufficient to satisfy human production and life, but are also feeling quite anxious about water resources, energy resources, and mineral resources. At the same time, in the process by which man develops and uses land resources, violations of the laws of natural science and plundering of natural resources lead to environmental pollution, a disruption of the ecological balance, and all these things are a threat to the existence of mankind. Therefore, the control of population growth, the rational development and utilization of natural resources, and protection of the natural ecological balance are major problems of common concern to the peoples of all countries of the world.

To initiate land resource surveys, to probe the extent of natural resources, to enhance management, to make decisionmaking correct, to rationally develop natural resources, to respect the laws of science, and to protect the natural ecological balance, these all require using advanced S&T means. The development of space remote-sensing technologies has expanded the boundaries of man's understanding of nature and his transformation of nature, and it is playing an ever-increasing role in national planning, management, and decisionmaking.

China is a country of vast territory and abundant resources, but one whose natural geographical conditions are extremely complex. To meet the demands of

national economic construction, we must develop comprehensive remote-sensing acquisition means and applications research that have multiple platforms, multiple transducers, multiple fields of production, and multiple technical disciplines. Over the last 20 some years, space technology in this country has made great achievements, and we have already successfully launched 19 satellites. The scientific exploration and technological experimental satellites that we have launched on several occasions have taken many photographs of China's territory, and this has not only produced excellent macroscopic results, but the ground resolution has been quite high (see Figure 1) [Figure 1 not reproduced]. As early as 1983, we sent back from space digital television-transmitted images using CCD sensitive devices (see Figure 2) [Figure 2 not reproduced]. Using these images, relevant scientific research organizations and sectors of national economic production did wide-ranging applications experiments, from which they obtained quite valuable results.

To satisfy the ever-increasing demand by all sectors of the national economy for space remote-sensing information, we in this country must develop and launch a series of global observation satellites, and in addition to the scientific exploration and technical experimentation satellites already successfully developed, we will soon launch China's first weather observation satellite. We have begun development of a China resources satellite, and our ocean satellite program has also entered the demonstration stage.

A country such as ours, with borders so vast and having such complex natural conditions, must have its own space system and must employ many talented remote-sensing information technical specialists before it can fully assume the heavy responsibility for surveying, developing, and managing our national resources.

In China, we primarily rely upon our own strength to develop our space technologies. But our implementation of the open door policy will have a greatly stimulating effect on developing China's space technology and on developing international exchanges and cooperation.

Survey, development, utilization, and management of land resources is a long-term effort of significance to decisionmaking. This effort requires the integration of this country's space remote sensing, aerial remote sensing, and regular surveying, and we must also make use of remote-sensing materials supplied by foreign satellites. And even more we need the cooperation of remote-sensing technology specialists from all countries of the world, for through joint efforts we can enrich mankind.

12586

CSO: 4008/2072

SATELLITE GROUND STATION PREPARES FOR OPERATIONS

Beijing XIANDAIHUA [MODERNIZATION] in Chinese No 1, Jan 87 p 9

[Article by Wang Xinmin [3769 2450 3046]: "Satellite Ground Stations"]

[Text] The mission of the remote-sensing satellite ground station at the Space Center of the Chinese Academy of Sciences is to receive, process, archive, and distribute various remote-sensing satellite data. Preparatory projects for the ground station have been completed, the system has gone into a test operations stage, and it will provide never-ending space remote-sensing data to remote-sensing application sectors throughout the country and to scientists and technicians, which will serve China's four modernizations.

The ground station that has been built can receive and process data from dedicated mapping instruments and multispectrum scanners on LANDSAT 4 and 5, and it also has the capability to receive and record data from the French SPOT satellite. Currently, processing systems for the SPOT satellite data are at the stage of installation debugging, and will be available for use in domestic checking and acceptance by the end of 1986.

China's remote-sensing satellite ground station is composed of two sites. Its reception and recording component is in the vicinity of Miyun County, some 100 km outside of Beijing Municipality, where electromagnetic interference is quieter and the geographical conditions are more ideal. The processing station is in the Haidian District of Beijing Municipality, where it is easier for remote-sensing customers to choose and use the space remote-sensing data. The satellite data received by the reception station is recorded on high-density magnetic tape, after which it is sent to the processing station for radiation correction and geometric correction, from which are generated digital tapes and photographic products.

The Miyun reception station covers the major portion of the area from the ground coverage area of LANDSAT 4 and 5, so as far as the interior of the country is concerned, that coverage area is 80 percent of China's land mass. We are currently considering setting up another reception station in the western part of this country. Then, the scope of coverage for the two stations would extend to the entire land mass of China.

The primary mission of the Miyun reception station is to capture and track satellites, to receive satellite instrument data, to correct remote measurement data as necessary, and to record that data on high-density tape for the processing station to correct and process.

The reception station has a 10-meter parabolic main reflector, with a 1.5-meter diameter auxiliary reflector and a Cassegrain structured antenna, and it has the capability of tracking the X and S bands throughout the hemisphere. The antenna is a positional--pitch installation with an automatic tilting mechanism, which resolves the problems when tracking the satellites past their apex. It has operational modes of manual and programmed tracking and automatic tracking, and will separately record the dispatched data on the tape of two high-density tape recorders, then send it for processing to the processing station. The high-density tape recorders have error checking and correcting equipment, and can automatically detect and correct one-bit errors and detect two-bit errors.

The receiving station has a PDP 11/24 computer, used for program-controlled tracking of the satellite and for orbit forecasting. There is a closed-loop automatic checking system in the computer room for checking the error rate performance of the reception system and its performance.

The main functions of the processing station are playback input and branch-circuit constant amplitude of the data that has been recorded on the high-density tape, to access and process PCD data that has been corrected as needed, to do geometric and radiation corrections on satellite data, and to generate digital products and photographic products.

Hardware equipment at the processing station includes two VAX 11/780 host computers and a system having an AP180v array processor as its core, with specialized peripheral equipment of various sorts. Internal memory capacity of each of the host computers has been expanded to 8 MB. Under control of the switchover and control systems, data recorded on the high-density tape is input to the computer system through a frame amplitude synchronizer for processing into the digital product that is required, which is then recorded on CCT tape. There are independent imaging subsystems in the processing station, where there are also a VAX 11/750 and color Fire 240 imaging equipment. It is also planned to soon add monochrome Fire 240 imaging equipment to meet customer demands. In addition to these things, there are four I2S Model 75 image analyzing terminals, which can be used for the analysis and interpretation of remote-sensing applications.

In the satellite data-processing flowchart system there are data-input software, PCD correction software, image data radiation correction software, system geometric correction software, ground station control point processing software, precision geometric correction software, digital product generation and output software, and photographic latent image generation software. Restart sampling operations can select from the most recent adjacent point method, bilinear interpolation, or cubic convolution for processing; for data in TM sweep interstices, the cubic spline function will do restart sampling. There are various commonly used map-projection software packages in the system, which will provide corresponding products as needed.

There are also in the system a displayed line-imaging data-management system, a quick-view system, and a support system for customers to look up data. Users can determine the world reference system (WRS) parameters or regions by latitude and longitude, select and access relevant information from image data stored at the reception station, and can browse through and skim the image products.

In the photographic processing room there are black-and-white and color film and photograph development equipment, and enlargement and copy equipment, as well as quality-control and inspection equipment.

Ground station digital products include radiation-corrected products (class A products), system-corrected products (PS class products), and precision-corrected products (PG class products). They all use the LTWG specification format, and normally they use the tape segment sequential format (BSQ) to record on computer-compatible tape at 6250 bpi or 1600 bpi. TM and MSS are all provided to the customer in units of amplitude correction. Specially processed products can be provided in accordance with customer needs.

Photographic products include the standard 240 mm color and black-and-white films and prints, as well as quick-view products for browsing by the customer. In accordance with customer needs, various special products can also be provided, the largest enlargements being 1.2 meters.

12586
CSO: 4008/2072

DEVELOPMENT OF S&T CONSULTING INDUSTRY DESCRIBED

Beijing XIANDAIHUA [MODERNIZATION] in Chinese No 1, Jan 87 pp 32-33

[Article by Zou Yi'an [6760 6654 1344] and Chen Puyuan [7115 2528 3293]: "The Rapidly Developing S&T Consulting Industry (part 2)"]

[Text] Powerfully Develop a Scientific and Technical Consulting Industry with Chinese Characteristics

Our efforts at S&T consulting will diligently implement this resolution, and under the leadership of all levels of government and with the broad support of society, we will continue to review our experiences and in practice take a new path in S&T consulting industry development that has Chinese characteristics, which will make its rightful contributions to the drive toward modernization.

First of all, the S&T consulting industry in this country must have a clear aim and guiding philosophy.

Ours is an S&T consulting industry with a socialist nature. The fundamental economic rule in a socialist society is to strongly develop socialist production forces, where the primary goal is to satisfy the ever-growing demand of the people for a material and civilized life. The S&T consulting industry in this country must respect this rule, and must make clear in its guiding ideology: that the fundamental goals of consulting activities are to use one's own intellectual capacity to the limit in providing S&T service for improving social production forces to develop society and the economy, which will satisfy the people's demands for material goods and culture. In actual consulting activities there are always particular immediate goals, but these must be restricted by this fundamental one.

The aims of S&T consulting ought to be: to earnestly implement and execute the principles and policies of the party, to strictly respect the laws, decrees, and regulations of the state, to strive to develop intellectual capacities, to serve the drive toward the "four modernizations," to advance the scientific nature of economic decisionmaking, to promote the progress of production technologies, and to improve enterprise quality and economic results. S&T consulting must also serve the aim of the S&T associations regarding the promotion of the development and dissemination of science and technology, as well as the promotion of the maturity and improvement of S&T skilled

personnel. Through consulting activities, the broad mass of S&T workers will be organized into promoting the flourishing development of science and technology, and to promote S&T applications.

S&T consulting is beneficial to society, the goal of which is service not profit, and it must place social results and the economic results of the commissioning unit in foremost positions. Of course, consulting is not done without compensation or without fees. Aside from consulting within the science association system, the consulting industry in all areas is of an industrial nature, with independent operations and responsibility for its own operations. Therefore, we must respect the laws of value, must guarantee the value of knowledge and labor, and must formulate science fee charging standards in accordance with the principle of allocation by labor and changes in the relations between supply and demand, and in keeping with the spirit of Document No 089 as issued by the Chinese Science Association and the State Ministry of Finance, all to achieve reasonable charging.

Second, let us make the most of China's S&T potential, develop the cause of consulting, and promote the realization of a new situation regarding the orientation of science and technology toward economic construction.

After more than 30 years of effort, the cause of science and technology in China has built up a number of research organizations and higher institutions that have reached a considerable level, and they have formed a contingent of S&T workers that is quite well-rounded and of a significant number. According to statistics, there are more than 4,300 science research organizations in China, with more than 330,000 research personnel; there are 420 soft science research organizations, with more than 15,000 research personnel; there are more than 670 higher institutions, with more than 247,000 full-time teachers; and there are more than 6.85 million people engaged in the natural sciences and technology, who have obtained more than 17,990 major S&T research achievements. This contingent has abundant S&T reserves and S&T knowledge, and it not only has a considerable level of science research capacity, but also has the S&T applications capability to resolve technical problems that arise in the building up of production. Intellectual resources that are this rich are a valuable source of wealth for our peoples, and if we rely upon them, we can be independent from the forest that is science and technology in the world. However, because abuses in the management system and the confines of ideology have obstructed the integration of science and technology with the economy and production, this potential capacity of the broad mass of scientists and technicians has not been realized. There are materials that show how of the 560 medium- to large-scale projects created during the period of the Sixth 5-Year Plan, 176, or 31 percent, could not normally realize their economic results after being placed in production due to a lack of scientific demonstration of their worth. Many problems for enterprises with production technology that are in urgent need of resolution can be solved solely through reliance on domestic S&T potential, but have long remained unresolved. This is an extremely apparent contradiction, and is a major topic for resolution during the period of restructuring. It is just as Comrade Deng Xiaoping has said: "It is not that we lack skilled personnel. Rather, the problem is whether or not we can organize them, motivate their enthusiasm, and make the most of their strengths... And that they be used appropriately is a very

great problem." Therefore, we must earnestly publicize and implement the strategic principle proposed by the Central Committee that "economic construction must rely upon science and technology, and science and technology must serve economic construction." We must strive to extract the S&T potential in this country, must organize the movement of intellectual abilities in a planned and purposeful manner, and must make efforts to develop the cause of S&T consulting, all to promote the achievement of a new situation regarding the closer integration of science and technology with economic construction.

Third, development of the cause of S&T consulting must gain the support and confidence of all levels of government and administrative leadership.

Decisionmaking after consulting is the integration of the intellectual capacity of S&T workers with the authority of leadership, and the leadership is the key to that integration; development of the cause of consulting lies in motivating the enthusiasm of both S&T workers and of leadership, and here, too, the key is the leadership. Therefore, leadership must respect knowledge, it must respect skilled personnel, must establish the strategic thinking that "economic construction must depend upon science and technology," and must recognize the scientific nature of consulting work; if the consulting industry can achieve the respect, support, and confidence of leadership, great development is inevitable. Recently at a national conference on soft science research, state leaders such as Wan Li have fully affirmed the importance of the soft sciences on leadership decisionmaking. The state has made the democratization and scientific nature of leadership decisionmaking an important matter for the restructuring of the political system, and has placed it on agendas. At the "Third Congress" of science associations throughout the country, Comrade Hu Qili [5170 0796 4539] represented the Central Committee in "encouraging and supporting S&T workers in presenting their ideas and suggestions for economic construction, technology decisionmaking, and social development." Comrade Zhou Peiyuan [0719 1014 3293] proposed in a report to the "Third Congress" that "initiating decisionmaking consulting and technical consulting on major projects centering on economic construction is an important aspect of service by science associations to economic construction." "We must actively take the initiative in cooperating with all levels of government, must rely on learned societies, must begin decisionmaking consulting, technical consulting, and feasibility demonstrations on behalf of developmental planning, construction programs, major projects, and major importation projects for regional governments, and must enhance tracking and feedback to do well as consultants for leadership decisionmaking." The state and many provinces and municipalities have learned the lessons of past experiences, and have made provisions that treat the consulting and demonstrations in decisionmaking as a legal process. We believe that this new entity that is S&T consulting will develop dramatically during the restructuring.

Consulting must also gain the support of the leadership of units in which personnel are engaged in consulting. Consulting in China is not the same as elsewhere, for those engaged in consulting are concurrently employed at something else. If this is not clearly recognized and supported by the leadership, there is sure to be reproach, which will affect the growth of

consulting. It is a natural trend in the intense growth of modern science and technology that S&T sectors become socialized, and as far as S&T personnel are concerned, in addition to completing their main tasking, they must also take on new social responsibilities. The Central Committee has ardently expected that at the same time as China's scientists provide even more research achievements to national economic construction, they will also apply their own knowledge and experience to propose valuable opinions and recommendations for major problems in the four modernizations. It has expected them to serve society, to publicize science and technology for cadres and the public, and to send science and technology to the factories and the farms. Therefore, it is an appropriate social task for the S&T sector and for scientists and technicians to participate in consulting, for which they should be praised by society. Over the past few years, all areas have reviewed and accumulated experience in this matter, and have recommended that relevant sectors of the state should formulate corresponding policies and methods.

Fourth, S&T consulting must fully realize its own characteristics and advantages.

As far as consulting by the science associations system is concerned, there are three of those characteristics and advantages: one, the science associations are the homes of scientists and technicians, and they have been the platforms and fronts created for the many scientists and technicians to develop their talents, to mature their abilities, and gain new knowledge. They, therefore, have great capacities to form and attract scientists and technicians. At the same time, we are mass organizations, having no concern for money, do not seek authority, have no finances or clout, are uncorrupted, and, when engaged in consulting, our positions are just and detached. Two, the work of the science associations has a rich social base, and they have formed a network system to channel information from all levels of science associations and learned societies throughout the country. And they have created favorable conditions for the growth of academics and science and technology. Three, learned societies of all levels have concentrated specialists of the first line and of high achievements, and thereby have a somewhat higher authority. In summary, we are an association of intellectual strength, where everything is a basis for intellectual consulting, for intellectual development, and intellectual service. By relying on our just and detached positions, if we can make the most of these advantages we can do a good job with consulting and can enjoy prestige in society.

Fifth, we must strengthen S&T consulting management and its basic construction.

The nearly 10,000 individuals currently in large and small consulting organizations throughout the country may be largely divided into four categories: 1) consulting organizations centered on decisionmaking consulting, serving government departments; two, 2) engineering and technical consulting organizations established by science research design units and higher institutions; 3) economic, management, and S&T professional consulting organizations that are civilian in nature; 4) consulting organizations oriented abroad. In actual practice over the past few years, consulting organizations of all levels have come to divide their efforts by function.

Consulting organizations in the state and provincial science association systems should become the core of a national and local consulting system because of their detachment and lateral associations. Professional consulting in all areas has professional advantages and is also at the frontlines, and should constitute the core of the entire system. The primary function of central consulting organizations should be: 1) to act as a brain trust for state decisionmaking organizations, and to develop decisionmaking consulting and strategic research; 2) to assume the management function for the entire system; 3) to enhance basic construction of the system, and to train consulting skilled personnel.

S&T consulting societies should be established throughout the country, and should take part in the basic build up of the entire consulting system. These learned societies would gradually establish S&T consulting legislation, and would verify the position, use, and function of consulting; they would enhance the quality and education of consulting personnel; they would establish relations with relevant governmental departments, would periodically report to central consulting organizations regarding the national economy, technology policies, and major plans and projects for construction, and they would explain relevant statistical materials and report information; central consulting organizations should progressively establish and perfect information retrieval systems and other channels for information circulation; they would coordinate and strengthen lateral relations among all consulting organizations throughout the country; and they would establish professional relations with international consulting research organizations.

(End of two-part series)

12586

CSO: 4008/2072

NICE-COMPACTNESS ON L-FUZZY TOPOLOGICAL SPACE

Beijing SHUXUE XUEBAO [ACTA MATHEMATICA SINICA] in Chinese Vol 29, No 4, Jul 86 pp 555-558

[Article by Peng Yuwei [1756 5148 1218]; paper received 15 March 1984; revised manuscript received 24 October 1985; first paragraph is source-supplied abstract]

[Text] Abstract: This paper uses the convergence theory of generalized topological membered lattices proposed by [9] to introduce nice compactness with respect to an L-Fuzzy topological space and discusses a series of its basic properties. We also provide the conditions for nice compactness and strong Q compactness equivalence of L-Fuzzy sets.

Compactness is the most important concept in topology, not only for topology itself, but also for other branches of mathematics where it has a profound influence. How rationally to generalize compactness to Fuzzy topology is a question of Fuzzy topology that has been a concern for some time. There have already been many studies of this problem in China and abroad which have introduced many sorts of definitions of Fuzzy compactness [1-5]. Comparing them, the nice compactness introduced by [1] is most ideal because it not only possesses the various basic properties desired but also because the Stone-Cech compactification theory and the compact open topology theory of Fuzzy function space constructed on its basis have proved successful [7,8]. However, the nice compactness in [1] was constructed for $L = [0, 1]$, which makes its application have large limitations. Consequently, how to generalize nice compactness to a general Fuzzy topological space also became a problem urgently awaiting study.

This paper first provides an equivalence division which does not rely on the $[0, 1]$ topological structure. Then, using the generalized topological membered lattices convergence theory proposed by [9] as a tool, we introduce nice compactness to L-Fuzzy space and discuss a series of its basic properties. The major results obtained in this paper all take the corresponding results of [1] as special examples.

In this paper $L = (\wedge, \vee, \geq, ')$ always represents the complete allocated lattice which possesses reversible convolution correspondence. The largest element in L is 1 and the smallest is 0 but $1 \neq 0$. $J(L)$ represents the set

of all union-complete reduced elements. $\mathcal{B}(\alpha)$ represents the minimal set of α [11]. $(0, \alpha] = \{x \in L: x \leq \alpha\}$, $J(\alpha) = J(L) \cap (0, \alpha]$.

X always represents the nonempty set and the function A of X to L is called the L-Fuzzy set of X . For other unexplained symbols and concepts refer to [1], [2], [9], and [10].

Definition 1 [9]. Let (L^X, δ) be an L-Fuzzy space. If L has a subset M , so that each element in L can be represented as the union of elements in M , and each L-Fuzzy point x_λ possesses δ' -limited union properties, x is the successor point of x_λ and λ is the high of x_λ , and $\lambda \in M$. At this time, the (L^X, δ) of the set with $[M] = \{x_\lambda: x \in X, \lambda \in M\}$ as members is called the generalized Fuzzy topological member lattice, denoted as $(L^X(M), \delta)$ and some times simply written as (X, δ) .

From lattice theory we know that the above membered set, M always exists (from theorem 3.15 of [14] we know it is allowed to set $M = J(L)$). Precisely said, for any L-Fuzzy space (X, λ) we can always select the appropriate membered set, M , to make it form a generalized Fuzzy topological membered lattice. Below, $V(e)$ represents the high of Fuzzy point e .

Definition 2. a) Let (X, λ) be a generalized Fuzzy topological membered lattice. If $e \in [M]$ and $V(e) = \alpha$, then call e an α -point. If $V(e) \geq \alpha$, then call e an α^+ -point.

b) Let $S = \{S(n): n \in D\}$ be the membered net of (X, δ) [9]. If $\forall n \in D, S(n)$ are all α -points (α^+ -points) then call S a constant value α -net (α^+ -net).

c) If $\bigwedge_{n \in D} \bigvee_{n \leq m} V(S(n)) = M(S) = \alpha > 0$, then call S an α -net; $\Lambda = \{V(S(n)): n \in D\}$ is called the constant value net of the S correspondence.

Lemma 1 [12]. The necessary and sufficient condition for α to be a union-complete reduced element of lattice L is that the minimal set of α form a directional set with respect to L .

Lemma 2. Let (X, δ) be a generalized Fuzzy topological membered lattice and $\alpha \in L \setminus 0$, then there exists a minimal subset of α , $\mathcal{B}(\alpha)$ such that $\mathcal{B}(\alpha) \subset M$.

Theorem 1. Let $S = \{S(n): n \in D\}$ be the α -net of (X, δ) . If $\lambda \in J(\alpha)$, then there exists in S a subnet T so that each subnet of T , $T \circ R$ satisfies $M(T \circ R) \geq \lambda$.

Corollary. Let S be an α -net of (X, δ) . If $\alpha \in J(L)$, then there exists in S a subnet T , such that each subnet of T is an α -net.

Below we introduce the definitions of nice compactness to L-Fuzzy topological space.

Definition 3. The Fuzzy set A of a generalized Fuzzy topological membered lattice $(L^X(M), \delta)$ is called a nice compact subset if any α -net S in A , for

$\forall \lambda \in (0, \alpha] \cap M$, there exists a subnet T of S satisfying $M(T) \geq \lambda$ and T has a limiting point belonging to A with a high of λ .

From Theorem 1, we directly deduce

Theorem 2. If $M \subseteq J(L)$ and A is a Fuzzy subset of $(L^X(M), \lambda)$ then the necessary and sufficient condition for A to be a nice compact set is that for any α -net in A , there is a cluster point belonging to A with a high of λ for $\forall \lambda \in J(\alpha) \cap M$.

When $L = [0,1]$, utilizing theorem 2 we will prove that the compactness defined by definition 3 is just the nice compacting of [1]. In other words we provide equivalence divisions for a topological structure that does not rely on $[0,1]$.

Theorem 3. Let A be a subset of the Fuzzy topological space $([0,1]^X, \delta)$, then the necessary and sufficient condition for A to be nice compact [1] is if the net $S = \{S(n) : n \in D\}$ in A satisfies $M(S) = \inf_{n \in D} \sup_{m \succ n} V(S(m)) = \alpha > 0$. Then S has a cluster point belonging to A with a high α .

Below we discuss the basic properties of L -nice compact subsets.

Theorem 4. A closed subset of a nice compact subset A is also nice compact and the intersection of a nice compact subset with a closed subset is also a nice compact subset.

The results below show that Fuzzy topology properties on a lattice can determine the algebraic structure of the lattice.

Theorem 5. Let A be the Fuzzy set of successor set of nonsingular points limited sets for $(L^X(M), \lambda)$, then the necessary and sufficient condition for A to be a nice compact set is that each member of M is a union-complete reduced element.

Definition 4. Let A be a Fuzzy set of X . Make $V[A] = \{\lambda \in M : \exists x \in \text{supp} A \text{ such that } x_\lambda \in A\}$. We say A is M accessible. If for every directional subset H with respect to $V[A]$, we have $\forall H \in M$, then $\forall H \in V[A]$.

Theorem 6. A nice compact subset of the generalized Fuzzy topological membered lattice is M accessible.

Theorem 7. Let $f: X \rightarrow Y$ be a continuous function of $(L^X(M), \delta)$ to $(L^Y(M), \mathcal{U})$ and let A be a nice compact set of $(L^X(M), \delta)$, then $f[A]$ is also a nice compact subset of $(L^Y(M), \mathcal{U})$.

The two lemmas below overcome the major difficulty encountered in the proof of the Tikhonov theorem.

Lemma 3. Let $A_i (i = 1, 2)$ be the nice compact subset of the generalized Fuzzy topological membered lattice $(X_i, \delta_i) (i = 1, 2)$, then the product set [2] $A = A_1 \times A_2$ is a nice compact subset of the product space $(X_1, \delta_1) \times (X_2, \delta_2)$.

Lemma 4. Let $\lambda \in (0, \alpha] \cap M$, then the α -net $S = \{S(n) : n \in D\}$ of the generalized Fuzzy topological membered lattice (X, δ) has a subnet T converging to x_λ and the necessary and sufficient condition for $M(T) \geq \lambda$ is that for the $\forall \beta \in \mathcal{B}(\lambda)$ ($\mathcal{B}(\lambda)$ is the minimal set of λ), $\forall N \in D$, and the far region B of $\forall x_\lambda$ [9], there exists $n \in D, n \geq N$ such that $S(n) \notin B$ and $V(S(n)) \geq \beta$.

Below we discuss the multiplicative properties of nice compact sets.

Theorem 8. Let A_γ be the nice compact set of the generalized Fuzzy topological membered lattice $(X_\gamma, \delta_\gamma)$ ($\gamma \in \Gamma$), then the product set A of each A_γ ($\gamma \in \Gamma$) is a nice compact set of the product space $(X, \delta) = \prod_{\gamma \in \Gamma} (X_\gamma, \delta_\gamma)$.

Finally, we discuss the relationship between nice compactness and strong Q compactness. Although the results obtained in this paper are similar to the discussion in [1], their work was done only for the special case of $L = [0, 1]$ and only delved into compact space.

Definition 5 [9][5]. The Fuzzy subset A of $(L^X(M), \delta)$ is strong Q compact if every α -constant value net in A has a cluster point α belonging to A .

It is easy to know that a Fuzzy set if nice compact is certainly strong Q compact but the converse is not necessarily established.

From lemmas 1 and 2 we immediately infer the following proposition:

Proposition: Let A be a strong Q compact set of $(L^X(M), \delta)$ and S be an α -net in A . If $\lambda \in M \cap (0, \alpha]$, then for $\forall \beta \in \mathcal{B}(\lambda) \subset M$, in S there exists a β^+ -subnet T and T has a cluster point belonging to A with a high of β .

Theorem 9. Let $M \subset J(L)$ then the necessary and sufficient condition for the Fuzzy set A to be nice compact is A be strong Q compact and, for every closed subset B of X , $A \cap B$ be M accessible.

Corollary 1. If $M \subset J(L)$, then the necessary and sufficient condition for the generalized Fuzzy topological membered lattice $(L^X(M), \delta)$ to be a nice compact space is that $(L^X(M), \delta)$ be strongly compact [3] and every closed subset be M accessible.

Corollary 2. If L is a completely ordered lattice, $M = L \setminus \{0\}$, then the Fuzzy unit interval $I(L)$ [6] is nice compact.

Corollary 3. When $M \subset J(L)$, the successor set of $(L^X(M), \delta)$ makes up a limited set Fuzzy set and is a nice compact subset.

Definition 6. The generalized Fuzzy topological membered lattice $(L^X(M), \delta)$ is called T_2 and if two different successor Fuzzy points, e_1 and e_2 exist and the individual far regions F_1 and F_2 satisfy $F_1 \cup F_2 = 1$.

It is easy to show that the necessary and sufficient condition for $(L^X(M), \delta)$ to be a T_2 space is that for any convergent membered net it cannot have limit points with different successor points.

Theorem 10. Let $M \subset J(L)$, $(L^X(M), \delta)$ be T_2 , then the necessary and sufficient condition for Fuzzy set A to be nice compact is that for any α -net S in A for $\forall \lambda \in (0, \alpha] \cap M$, $\forall \beta \in \mathcal{B}(\lambda) \subset M$, S has a cluster point belonging to A with a high of β .

Corollary. If $M \subset J(L)$, $(L^X(M), \delta)$ is T_2 , then Fuzzy set A is nice compact if and only if A is strong Q compact.

The author expresses his appreciation for the guidance of Professor Liu Yingming [0491 2019 2494].

REFERENCES

1. Wang Guojun [3769 0948 0193], "A New Fuzzy Compactness Defined by Fuzzy Net," J. MATH. ANAL. APPL., 94(1983), 1-24.
2. Liu Yingming [0491 2019 2494], "Compactness of Unresolved Topological Spaces and the Tikhonov Theorem," SHUXUE XUEBAO [ACTA MATHEMATICA SINICA], 24(1981), 260-268.
3. Gantner, T.E., R.C. Steinlage, and R.H. Warren, "Compactness in Fuzzy Topological Space," J. MATH. ANAL. APPL., 62(1978), 547-562.
4. Lowen, R., "A Comparison of Different Compactness Notions in Fuzzy Topological Space," J. MATH. ANAL. APPL., 64(1978), 446-454.
5. Li Zhongfu [2621 0022 1133], "Compactness of Unresolved Topological Spaces," KEXUE TONGBAO [SCIENCE BULLETIN], 29:6(1984), 321-323.
6. Liu Yingming, "Unresolved Stone-Cech Compactization," SHUXUE XUEBAO [ACTA MATHEMATICA SINICA], 26:4(1983), 507-512.
7. Peng Yuwei [1756 5148 1218], "Topological Structure of Unresolved Function Spaces--Point Wise Convergent Topology and Compact Open Topology," KEXUE TONGBAO, 28(1983), 836-838.
8. ———, "Unresolved Ascoli Theorem," MOHU SHUXUE ZAZHI [FUZZY MATHEMATICS JOURNAL], 3(1985), 21-24.
9. Wang Guojun, "Generalized Topological Membered Lattices II," ZHONGGUO KEXUE [SCIENTIA SINICA], 12(A) (1983), 1063-1072.
10. Liu Yingming, "Point Type Division of Complete Regularity in Unresolved Topological Spaces and the Imbedding Theorem," ZHONGGUO KEXUE [SCIENTIA SINICA], 8(1982), 673-680.

11. Hutton, B., "Uniformities on Fuzzy Topological Space," J. MATH. ANAL. APPL., 58(1977), 559-571.
12. Peng Yuwei, "Properties of Union-Complete Reduced Elements of Complete Allocated Lattices and the Algebraic Structure of Membered Lattices," GONGCHENG SHUXUE XUEBAO [JOURNAL OF ENGINEERING MATHEMATICS] (forthcoming).
13. ———, "Geometric Division of L-Nice Compact Subsets," SHUXUE JINZHAN [ADVANCES IN MATHEMATICS] (forthcoming).
14. Gierz, G., K.H. Hofmann, K. Keimel, J.D. Lawson, M. Mislove, and D.S. Scott, "A Compendium of Continuous Lattices," Heidelberg/New York: Springer-Verlag, 1980.

12966/6091
CSO: 4008/1030

EXPANSION OF $|U|U$ IN FOURIER SERIES AND THE SEA BOTTOM DRAG COEFFICIENT C_D IN THE BOHAI SEA

Beijing HAIYANG YU HUZHAO [OCEANOLOGIA ET LIMNOLOGIA SINICA] in Chinese
Vol 18, No 1, Jan 87 pp 1-11

[Article by Zhou Meng [0719 2603] and Fang Guohong [2455 0948 3163] of the Chinese Academy of Sciences, Institute of Oceanography, Qingdao; Chinese Academy of Sciences, Institute of Oceanography survey report No 1376; paper received 21 November 1984; first two paragraphs are source-supplied abstract]

[Text] Abstract: In tidal dynamics, bottom drag plays an important role in the interaction of tidal components. This paper takes the bottom drag term which is in direct proportion to the square of the velocity and expands it in a Fourier series. It also discusses the interference between tidal components caused by the bottom drag.

From the nonlinear momentum equation we obtain the mechanical energy equation. Using the above Fourier series, this paper provides a method, from the mechanical energy equation, to solve for the average drag coefficient C_D in a certain region. Applying this method to the Bohai Sea we obtained a drag coefficient of $C_D = 0.0013$.

In tidal dynamics computations, the Reynolds equations are commonly used under the assumption of quasi-static balance to integrate the average along the depth obtaining an average flow equation. The bottom friction term in this equation takes the form of $\frac{C_D}{h + \zeta} |U|U$ after substituting the assumptions of Prandtl mixing long theory and Von Karman similarity. When multiple tides are present, the bottom friction plays an important role in the interference between tidal components. A major method of engaging in discussion with respect to the bottom friction is its Fourier expansion. Dronkers [4,5], Fang Guohong [2455 0948 3163] [1], and Le Provost [8] have provided different exact and approximate solutions. However, the 2-dimensional, multiple wave problem has not been solved well. The approximate Fourier series expansion of the bottom friction under any number of waves provided by this paper has a higher level of accuracy and a broader range of applicability.

In 1919, Taylor derived the mechanical energy conservation equation from the linear momentum equation and studied the question of the tidal energy balance

in the Irish Sea. In 1953, Proudman [3] used Taylor's data to estimate the energy dissipation of the M_2 tidal component of the Irish Sea, approximating the bottom drag coefficient $C_D = 0.0026$. This paper, beginning from the nonlinear momentum equation, derives the equation of mechanical energy conservation and considers the tidal components M_2 , O_1 , and K_1 to seek the input and dissipation of average tidal energy in the Bohai Sea. We obtained a bottom drag coefficient for the Bohai Sea of $C_D = 0.0013$.

I. Mechanical Energy Conservation Equations

Long after Taylor, in 1919, obtained the mechanical energy equation from the linear momentum equation, Garrett, working in 1974, made several corrections to the gravitational tidal force term in Taylor's mechanical energy conservation equation. Pingree [11], for conditions ignoring the gravitational tidal force, got the mechanical energy conservation equation from the nonlinear momentum equation. This paper, by not ignoring the nonlinear momentum equation of the gravitational tidal force, derives a mechanical energy conservation equation of an entirely differential form. Further, an energy conservation equation in integral form is obtained for a given region.

We use the 2-dimensional momentum equation and the continuity equation which integrate the average over the depth. (Footnote 1) (In deriving the average flow equation and defining the kinetic energy, we assume the following form:

$$\int_{-h}^{\zeta} \mathbf{U}(x, y, z, t) \cdot \mathbf{U}(x, y, z, t) dz \doteq (h + \zeta) \mathbf{U} \cdot \mathbf{U}$$

In region S , let

$$\frac{\partial \mathbf{U}}{\partial t} + \mathbf{U} \cdot \nabla \mathbf{U} + \mathbf{f} \times \mathbf{U} = -g \nabla (\zeta - \zeta_c) - \frac{C_D}{h + \zeta} |\mathbf{U}| \mathbf{U} \quad (1.1a)$$

$$\frac{\partial \zeta}{\partial t} + \nabla \cdot \{ (h + \zeta) \mathbf{U} \} = 0 \quad (1.1b)$$

On the boundary Γ of S , these satisfy the boundary conditions

$$\mathbf{n} \cdot \mathbf{U}|_{\Gamma} = 0 \quad (1.2a)$$

$$\mathbf{n} \cdot \mathbf{U}|_{\Gamma} = \varphi_0(x, y, t) \quad (1.2b)$$

in which \mathbf{U} is the average surface flow velocity along the vertical direction; $\mathbf{f} = 2\Omega \sin \phi \mathbf{k}$, Ω is the earth's angular velocity of rotation, ϕ is the latitude, \mathbf{k} is the unit vector in the vertical direction; ζ is the height of the wave face relative to the average sea level; $g\zeta_c$ is the gravitational tidal force potential; h is water depth relative to the average sea level; \mathbf{n} is external normal unit vector at the boundary; φ_0 is a known function; and ∇ is the surface gradient operator. The sea water density is taken as a constant.

Selecting the average sea level as the point of zero potential energy, the total mechanical energy of a unit cross-section fluid column is

$$E = \frac{1}{2} (h+\zeta) \mathbf{U} \cdot \mathbf{U} + \frac{1}{2} (h+\zeta)(\zeta-h)g \quad (1.3)$$

from which we can get the mechanical energy conservation equation

$$\begin{aligned} \frac{\partial E}{\partial t} = & -\nabla \cdot \{E\mathbf{U}\} - \nabla \cdot \left\{ \frac{1}{2} (h+\zeta)^2 g \mathbf{U} \right\} \\ & + g(h+\zeta) \mathbf{U} \cdot \nabla \zeta - C_D |\mathbf{U}|^3 \end{aligned} \quad (1.4)$$

The left side of the equation above represents the rate of change of the total mechanical energy over time. The terms of the right side of the equation are, respectively: diffusion, action of pressure on the fluid, gravitational tidal force action, and turbulence dissipation.

Taking formula (1.4) and integrating on region S, we get the mechanical energy equation in integral form:

$$\begin{aligned} \frac{\partial}{\partial t} \iint_S E ds = & - \int_L E \mathbf{U} \cdot \mathbf{n} dl - \int_L \frac{1}{2} (h+\zeta)^2 g \mathbf{U} \cdot \mathbf{n} dl \\ & + \iint_S g(h+\zeta) \mathbf{U} \cdot \nabla \zeta ds - \iint_S C_D |\mathbf{U}|^3 ds \end{aligned} \quad (1.5)$$

The left side of (1.5) represents the change over time of the total mechanical energy in the region S. On the right side, the first term represents the energy flowing in through the open boundary L; the second term is the work done by pressure when fluid enters the region through the open boundary; the third term is work done by the gravitational tidal force with respect to the entire region S; and the fourth term is energy dissipation caused by the bottom friction in the entire region.

II. Fourier Expansion of $|\mathbf{U}|\mathbf{U}$

The friction term is $\frac{C_D}{h+\zeta} |\mathbf{U}|\mathbf{U} = \frac{C_D}{h} \left(1 + \frac{\zeta}{h} + \dots \right) |\mathbf{U}|\mathbf{U}$. Here we only discuss the Fourier expansion of $|\mathbf{U}|\mathbf{U}$. If we want to consider the influence of the small magnitude high order terms inside the parenthesis, it is not difficult after the expansion of $|\mathbf{U}|\mathbf{U}$.

\mathbf{U} can be written in the following form

$$\mathbf{U} = \sum_{j=1}^{\infty} \{ U_j \cos(\sigma_j t - \xi_j) \mathbf{i} + V_j \cos(\sigma_j t - \eta_j) \mathbf{j} \} \quad (2.1)$$

in which σ_j is the frequency of the tidal component; ξ_j, η_j are delay angles; and U_j, V_j are amplitudes. When $\sigma_j = 0, \xi_j = \eta_j = 0, \tilde{U}_j, \tilde{V}_j$ represent residual flows. The formulae below only take the front few major tidal components, i.e.

$$\mathbf{U} = u\mathbf{i} + v\mathbf{j} \quad (2.2a)$$

$$u = \sum_{j=1}^n U_j \cos(\sigma_j t - \xi_j) \quad (2.2b)$$

$$v = \sum_{j=1}^n V_j \cos(\sigma_j t - \eta_j) \quad (2.2c)$$

Consequently, $U_j, V_j \geq 0$ and $|\cos(\sigma_j t - \xi_j)|, |\cos(\sigma_j t - \eta_j)| \leq 1, (j = 1, \dots, n)$, so

$$\left| \frac{u^2 + v^2}{A_0} - 1 \right| \leq 1 \quad (2.3)$$

in which

$$A_0 = \frac{1}{2} \left\{ \left(\sum_{j=1}^n U_j \right)^2 + \left(\sum_{j=1}^n V_j \right)^2 \right\} \quad (2.4)$$

Using Newton's binomial expansion theorem, we have

$$\begin{aligned} |\mathbf{U}| &= (u^2 + v^2)^{\frac{1}{2}} \\ &= A_0^{1/2} \left[1 + \left(\frac{u^2 + v^2}{A_0} - 1 \right) \right]^{\frac{1}{2}} \\ &= A_0^{1/2} \left\{ 1 + \sum_{k=1}^{\infty} \frac{\frac{1}{2} \left(\frac{1}{2} - 1 \right) \dots \left(\frac{1}{2} - k + 1 \right)}{k!} \left(\frac{u^2 + v^2}{A_0} - 1 \right)^k \right\} \end{aligned} \quad (2.5)$$

The convergence of the above formula is ensured by (2.4).

From formula (2.2), u, v can be written as

$$u = \sum_{j=1}^n \tilde{U}_j \{ e^{i(\sigma_j t - \xi_j)} + e^{-i(\sigma_j t - \xi_j)} \} \quad (2.6a)$$

$$v = \sum_{j=1}^n \tilde{V}_j \{ e^{i(\sigma_j t - \eta_j)} + e^{-i(\sigma_j t - \eta_j)} \} \quad (2.6b)$$

in which $\tilde{U}_j = \frac{1}{2} U_j, \tilde{V}_j = \frac{1}{2} V_j, (j = 1, 2, \dots, n)$. From formulae (2.5) and (2.6) we get the expansion formulae for $|\mathbf{U}|$

$$\begin{aligned}
|U|u &= A_0^{1/2} \sum_{\mu=1}^n \tilde{U}_\mu (e^{i(\sigma_\mu t - \xi_\mu)} + e^{-i(\sigma_\mu t - \xi_\mu)}) \\
&+ A_0^{1/2} \sum_{k=1}^{\infty} \sum_{l=0}^k \sum_{r=0}^l \sum_{\substack{p_j, q_j, \beta_j \geq 0 \\ p_1 + \dots + p_{2n} = 2r \\ q_1 + \dots + q_{2n} = 2(l-r) \\ \beta_1 + \dots + \beta_{2n} = 1}} (-1)^l \\
&\times \frac{\frac{1}{2} \left(\frac{1}{2} - 1\right) \dots \left(\frac{1}{2} - k + 1\right) (2r)! (2l - r)!}{A_0^l (k - l)! (l - r)! r!} \cdot \left(\prod_{j=1}^n \frac{\tilde{U}^{p_j + p_{n+j} + \beta_j + \beta_{n+j}} \tilde{V}^{q_j + q_{n+j}}}{p_j! p_{n+j}! q_j! q_{n+j}! \beta_j! \beta_{n+j}!} \right) \\
&\cdot e^{i \sum_{j=1}^n [(p_j - p_{n+j} + q_j - q_{n+j} + \beta_j - \beta_{n+j}) \sigma_j t - (p_j - p_{n+j} + \beta_j - \beta_{n+j}) \xi_j - (q_j - q_{n+j}) \eta_j]} \tag{2.7}
\end{aligned}$$

$$\begin{aligned}
|U|v &= A_0^{1/2} \sum_{\mu=1}^n \tilde{V}_\mu (e^{i(\sigma_\mu t - \eta_\mu)} + e^{-i(\sigma_\mu t - \eta_\mu)}) + A_0^{1/2} \sum_{k=1}^{\infty} \sum_{l=0}^k \sum_{r=0}^l \sum_{\substack{p_j, q_j, \beta_j \geq 0 \\ p_1 + \dots + p_{2n} = 2r \\ q_1 + \dots + q_{2n} = 2(l-r) \\ \beta_1 + \dots + \beta_{2n} = 1}} \\
&\cdot (-1)^l \frac{\frac{1}{2} \left(\frac{1}{2} - 1\right) \dots \left(\frac{1}{2} - k + 1\right) (2r)! (2l - 2r)!}{A_0^l (k - l)! (l - r)! r!} \\
&\cdot \left(\prod_{j=1}^n \frac{\tilde{U}^{p_j + p_{n+j}} \tilde{V}^{q_j + q_{n+j} + \beta_j + \beta_{n+j}}}{p_j! p_{n+j}! q_j! q_{n+j}! \beta_j! \beta_{n+j}!} \right) \\
&\cdot e^{i \sum_{j=1}^n [(p_j - p_{n+j} + q_j - q_{n+j} + \beta_j - \beta_{n+j}) \sigma_j t - (p_j - p_{n+j}) \xi_j - (q_j - q_{n+j} + \beta_j - \beta_{n+j}) \eta_j]} \tag{2.8}
\end{aligned}$$

In 1-dimensional situations, we only need to use formula (2.7). When there are only two waves present, (2.7) can be written as

$$|U|U = \sum_{\mu} \sum_{\lambda} C_{\mu\lambda} U_1^2 \cos[(\mu\sigma_1 + \lambda\sigma_2)t - (\mu\xi_1 + \lambda\xi_2)] \tag{2.9}$$

In which $C_{\mu\lambda}$ is a function of U_1 and U_2 . In applying formula (2.7) a limiting term can be taken. Fang Guohong [2455 0948 3163] [1] provided the exact solutions of

$$C_{10}^* = \frac{16}{9\pi^2} [(7 + s^2)E - 4(1 - s^2)K] \tag{2.10}$$

$$C_{01}^* = \frac{16}{9s\pi^2} [(1 + 7s^2)E - (1 + 3s^2)(1 - s^2)K] \tag{2.11}$$

in which $s = U_2/U_1$; K, E are the first and second type complete elliptic integrals. In order to examine the accuracy of the series expansion Table 1 below, for $k \leq 2$ hrs, gives the approximate value of $C_{\mu\lambda}$ and the exact solution $C_{\mu\lambda}^*$, as well as their relative difference, δ .

Table 1. Comparison of the Approximate and Exact Values for the Expansion Series of $|u|$ with Two Waves in One Dimension

U_2/U_1	0.0	0.1	0.2	0.3	0.4	0.5	0.6	0.7	0.8	0.9	1.0
C_{10}	0.8397	0.8533	0.8750	0.9094	0.9572	1.0173	1.0880	1.1677	1.2550	1.3486	1.4473
C_{10}^*	0.8488	0.8552	0.8743	0.9058	0.9497	1.0055	1.0727	1.1508	1.2413	1.3371	1.4410
$\delta(\%)$	1.07	0.3	0.08	0.4	0.8	1.2	1.4	1.5	1.1	0.9	0.4
C_{01}	0	0.1237	0.2512	0.3800	0.5110	0.6461	0.7874	0.9366	1.0955	1.2654	1.4473
C_{01}^*	0	0.1257	0.2560	0.3863	0.5196	0.6567	0.7989	0.9471	1.1047	1.2676	1.4410
$\delta(\%)$	0	3.0	1.9	1.6	1.6	1.6	1.4	1.1	0.6	0.2	0.4

From Table 1 it is evident that formula (2.9) for $k \leq 2$ hrs can give a very good approximation. The expansion method for $|U|$ can be extended to the situation of $|U|^\alpha$:

$$\begin{aligned}
 |U|^\alpha = A_0^{\alpha/2} \left\{ 1 + \sum_{k=1}^{\infty} \sum_{l=0}^k \sum_{r=0}^l \sum_{\substack{p_j, q_j \geq 0 \\ p_1 + \dots + p_{2n} = 2r \\ q_1 + \dots + q_{2n} = 2(l-r)}} \right. \\
 \cdot (-1)^l \frac{\frac{\alpha}{2} \left(\frac{\alpha}{2} - 1 \right) \dots \left(\frac{\alpha}{2} - k + 1 \right) (2r)! (2l - 2r)!}{A_0^l (k-l)! (l-r)! r!} \\
 \left. \cdot \left(\prod_{j=1}^n \frac{\tilde{U}^{p_j + p_{n+i}} \tilde{V}^{q_j + q_{n+i}}}{p_j! p_{n+i}! q_j! q_{n+i}!} \right) e^{i \sum_{j=1}^n [(p_j - p_{n+i} + q_j - q_{n+i}) \sigma_j t - (p_j - p_{n+i}) \xi_j - (q_j - q_{n+i}) \eta_j]} \right\} \quad (2.12)
 \end{aligned}$$

III. Fourier Expansion of $|U|^3$

In the energy equation where we require the Fourier expansion of $|U|^3$, we could use formula (2.12) directly. However, using the same as the momentum equation, we still use formula (2.5). Multiplying formula (2.5) by $u^2 + v^2$, the Fourier expansion of $|U|^3$ can be obtained. In Table 2, for two waves in one dimension, we provide the constant term of $|U|^3$ given for k taken as 2 hrs, that is the time average value \mathcal{D} of $|U|^3$ and the exact value \mathcal{D}^* obtained from formulae (2.10) and (2.11), as well as the relative difference Δ .

Table 2. Comparison of the Approximate and Exact Values for the Expansion Series of $|U|^3$ With Two Waves in One Dimension

U_2/U_1	0.0	0.1	0.2	0.3	0.4	0.5	0.6	0.7	0.8	0.9	1.0
\emptyset	0.4198	0.4328	0.4626	0.5117	0.5808	0.6702	0.7802	0.9117	1.0657	1.2437	1.4474
\emptyset^*	0.4244	0.4340	0.4627	0.5108	0.5788	0.6669	0.7760	0.9069	1.0626	1.2390	1.4410
$\Delta(\%)$	1.1	0.3	0.03	0.2	0.4	0.5	0.5	0.5	0.3	0.4	0.5

Note: in the table, $U_1 = 1$.

IV. Discussion of $|U|U$

From formulae (2.7) and (2.8), we obtained the bottom friction corresponding to the various tidal components. We already know the tidal component tide flow

$$u_i = U_i \cos(\sigma_i t - \xi_i)$$

$$v_i = V_i \cos(\sigma_i t - \eta_i)$$

corresponds to a tide flow ellipse. Similarly, the σ_i component F_i of the bottom friction, F also corresponds to an ellipse. Below we discuss the relationship between monowave and dual wave tidal flow ellipses and bottom friction.

1. Monowave

The major axis of the tidal flow ellipse is along the x direction and the semimajor axis is along the y direction (see Figure 1). Then the tidal flow can be represented as

$$u = U \cos(\sigma t - \phi) \quad (4.1a)$$

$$v = \pm V \sin(\sigma t - \phi) \quad (4.1b)$$

Denoting $C_D F_x$ and $C_D F_y$ as the components in the x and y directions of a bottom friction which corresponds to a frequency of σ and also writing $\mu = V/U$, $\mu \leq 1$. From the two formulae (2.7) and (2.8) we can get

$$F_x = \frac{19 + 34\mu^2 + 11\mu^4}{16\sqrt{2}(1 + \mu^2)^{\frac{3}{2}}} U^2 \cos(\sigma t - \phi) \quad (4.2a)$$

$$F_y = \pm \frac{11 + 34\mu^2 + 19\mu^4}{16\sqrt{2}(1 + \mu^2)^{\frac{3}{2}}} \mu U^2 \sin(\sigma t - \phi) \quad (4.2b)$$

The \pm sign in (4.1) and (4.2) indicates the direction of rotation of the ellipse. The ellipticity, K , of the bottom friction ellipse can be gotten as

$$K = \frac{11 + 34\mu^2 + 19\mu^4}{19 + 34\mu^2 + 11\mu^4} \mu \quad (4.3)$$

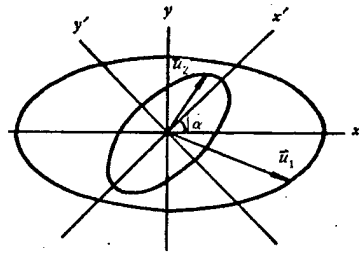

Figure 1. Tide Flow Ellipse

From (4.2) we see that the rotation direction of the bottom friction ellipse is the same as for the tidal flow. Moreover, the directions of the major and semimajor axes are also the same. At the same time, K satisfies the inequality below.

$$0.58\mu \leq K \leq \mu \quad (4.4)$$

that is, except for situation where for $\mu = 0$ or $\mu = 1$, the bottom friction ellipse will be flatter than the tidal flow ellipse.

2. Dual Wave

Let there be two tidal components denoted separately as U_1 and U_2 and denote the bottom friction components corresponding to the frequency as F_1 and F_2 . Pick the major axis of U_1 as the x axis and the semimajor axis as the y axis. The major axes of U_1 and U_2 form an angle α . For convenience sake stipulate that $|\alpha| \leq \pi/2$. In xoy coordinates U_1 is

$$u_1 = U_1 \cos(\sigma_1 t - \xi_1) \quad (4.5a)$$

$$v_1 = \pm V_1 \sin(\sigma_1 t - \xi_1) \quad (4.5b)$$

let x' , y' in $x'oy'$ coordinates correspond to the major and semimajor axes of U_2 . Then U_2 can be represented as

$$u'_2 = a \cos(\sigma_2 t - \varphi) \quad (4.6a)$$

$$v'_2 = \pm b \sin(\sigma_2 t - \varphi) \quad (4.6b)$$

In the xoy coordinate system, U_2 can be written as

$$u'_2 = U_2 \cos(\sigma_2 t - \xi_2) \quad (4.7a)$$

$$v'_2 = V_2 \cos(\sigma_2 t - \eta_2) \quad (4.7b)$$

in which

$$U_2 = \sqrt{a^2 \cos^2 \alpha + b^2 \sin^2 \alpha} \quad (4.8a)$$

$$V_2 = \sqrt{a^2 \sin^2 \alpha + b^2 \cos^2 \alpha} \quad (4.8b)$$

$$\xi_2 = \varphi \pm \arcsin \frac{-b \sin \alpha}{\sqrt{a^2 \cos^2 \alpha + b^2 \sin^2 \alpha}} \quad (4.8c)$$

$$\eta_2 = \varphi \pm \arccos \frac{a \sin \alpha}{\sqrt{a^2 \sin^2 \alpha + b^2 \cos^2 \alpha}} \quad (4.8d)$$

Not losing generality, below we let $U_1 \geq V_1$, $a \geq b$.

Denote the corresponding x and y components of F_1 as $C_D F_{1x}$ and $C_D F_{1y}$. Based on (2.7) and (2.8)

$$\mathbf{F}_1 = C_D \begin{pmatrix} F_{1x} \\ F_{1y} \end{pmatrix} = C_D \begin{pmatrix} A_{11} & A_{12} \\ A_{21} & A_{22} \end{pmatrix} \begin{pmatrix} U_1 \cos(\sigma_1 t - \xi_1) \\ \pm V_1 \sin(\sigma_1 t - \xi_1) \end{pmatrix} \quad (4.9)$$

in which $A_{ij} = A_{ij}(U_1, V_1, a, b, \alpha)$ and also satisfies $A_{21} = A_{12}$ and

$$A_{11}A_{22} - A_{12}^2 \geq 0$$

We can also get the ellipticity K of F_1 as well as the angle α between the major axis and the x axis:

$$K = \frac{\left(\frac{A_{22}}{A_{11}} - \frac{A_{12}^2}{A_{11}^2} \right) (1 + K^2) \mu}{1 + \frac{A_{12}^2}{A_{11}^2} (1 + \mu^2) + \frac{A_{22}^2}{A_{11}^2} \mu^2} \quad (4.10)$$

$$\varphi = \operatorname{arctg} \left\{ \frac{1 + \mu K}{1 - \left(\frac{A_{22}}{A_{11}} \right) \mu K} \cdot \frac{A_{21}}{A_{11}} \right\} \quad (4.11)$$

in which $\mu = V_1/U_1$. K in formula (4.10) has two solutions; one is the ellipticity and the other is its reciprocal. Obviously, we can only take the solutions where $K \leq 1$.

Based on formulae (4.9)-(4.11) we can obtain the following properties of F_1 :

- (1) The rotation direction of F_1 is determined by the rotation direction of U_1 and is not related to U_2 .
- (2) The direction of tilt of F_1 is the same as for U_2 ; in general $|\varphi| \leq |\alpha|$.
- (3) The ellipticity K , of F_1 satisfies the inequality $0.55\mu \leq K \leq 1$.

V. Estimation of the Drag Coefficient C_D

Because C_D and the coarseness of the sea bottom are closely related, for different places it has different values. Using formula (1.5) one is only able to get an overall estimate of C_D for a certain region. Seeking the average in the time interval $(-\infty, +\infty)$, we get

$$\begin{aligned} \lim_{T \rightarrow \infty} \frac{1}{2T} \int_{-T}^T \frac{\partial}{\partial t} \iint_S E ds dt &= - \lim_{T \rightarrow \infty} \frac{1}{2T} \int_{-T}^T \int_L E \mathbf{U} \cdot \mathbf{n} dl dt - \lim_{T \rightarrow \infty} \frac{1}{2T} \int_{-T}^T \int_L \\ &\cdot \frac{1}{2} (h + \zeta)^2 g \mathbf{U} \cdot \mathbf{n} dl dt + \lim_{T \rightarrow \infty} \frac{1}{2T} \int_{-T}^T \iint_S g(h + \zeta) \mathbf{U} \\ &\cdot \nabla \zeta_e ds dt - \lim_{T \rightarrow \infty} \frac{1}{2T} \int_{-T}^T \iint_S C_D |\mathbf{U}|^3 ds dt \end{aligned} \quad (5.1)$$

The integrals of the above formula and the limited sequence can be exchanged. Obviously the left side of the equality equals zero. On the right side of the equality, each term can be expanded into a series of sums of harmonic and constant terms. The average value of all the harmonic terms is zero. We denote

$$\mathcal{D} = \lim_{T \rightarrow \infty} \frac{1}{2T} \int_{-T}^T |\mathbf{U}|^3 dt \quad (5.2a)$$

$$\mathcal{E} = \lim_{T \rightarrow \infty} \frac{1}{2T} \int_{-T}^T E \mathbf{U} \cdot \mathbf{n} dt \quad (5.2b)$$

$$\mathcal{F} = \lim_{T \rightarrow \infty} \frac{1}{2T} \int_{-T}^T (h + \zeta)^2 \mathbf{U} \cdot \mathbf{n} dt \quad (5.2c)$$

$$\mathcal{G} = \lim_{T \rightarrow \infty} \frac{1}{2T} \int_{-T}^T (h + \zeta) \mathbf{U} \cdot \nabla \zeta_e dt \quad (5.2d)$$

The above formulae equal the individual constant terms. Simultaneously, ζ , $\nabla \zeta_e$ are separately denoted as

$$\begin{aligned} \zeta &= \sum_{j=1}^n H_j \cos(\sigma_j t - \theta_j) \\ &= \sum_{j=1}^n \tilde{H}_j [e^{i(\sigma_j t - \theta_j)} + e^{-i(\sigma_j t - \theta_j)}] \end{aligned} \quad (5.3)$$

$$\begin{aligned} X \equiv \frac{\partial \zeta_e}{\partial x} &= \sum_{k=1}^n \Phi_{ek} \cos(\sigma_k t - \phi_k - 90^\circ) \\ &= \sum_{k=1}^n \tilde{\Phi}_{ek} [e^{i(\sigma_k t - \phi_k - 90^\circ)} + e^{-i(\sigma_k t - \phi_k - 90^\circ)}] \end{aligned} \quad (5.4)$$

$$\begin{aligned}
Y &\equiv \frac{\partial \zeta_c}{\partial y} = \sum_{k=1}^n \Phi_{nk} \cos(\sigma_k t - \psi_k) \\
&= \sum_{k=1}^n \tilde{\Phi}_{nk} [e^{i(\sigma_k t - \phi_k)} + e^{-i(\sigma_k t - \phi_k)}]
\end{aligned} \tag{5.5}$$

in which x, y are the eastern and northern directions respectively in orthogonal Cartesian coordinates.

$$\tilde{H}_j = \frac{1}{2} H_j, \quad \tilde{\Phi}_{nk} = \frac{1}{2} \Phi_{nk}, \quad \tilde{\Phi}_{ck} = \frac{1}{2} \Phi_{ck}.$$

Denote $\Sigma(L, M, N, R)$ as the summation operator which satisfies

$$\begin{aligned}
&\Sigma(L, M, N, R) f_{i_1, \dots, i_{2n}; j_1, \dots, j_{2n}; k_1, \dots, k_{2n}; l_1, \dots, l_{2n}} \\
&\equiv \sum_{\substack{i_p, j_p, k_p, l_p \geq 0 \\ i_1 + \dots + i_{2n} = L \\ j_1 + \dots + j_{2n} = M \\ k_1 + \dots + k_{2n} = N \\ l_1 + \dots + l_{2n} = R}} f_{i_1, \dots, i_{2n}; j_1, \dots, j_{2n}; k_1, \dots, k_{2n}; l_1, \dots, l_{2n}} \\
&\sum_{p=1}^n (i_p - i_{n+p} + j_p - j_{n+p} + k_p - k_{n+p} + l_p - l_{n+p}) \sigma_p = 0
\end{aligned}$$

The above formula satisfies (1) that $i_p, j_p, k_p, l_p \geq 0$ ($p = 1, \dots, 2n$) are positive integers and (2) that $i_1 + i_2 + \dots + i_{2n} = L$, $j_1 + \dots + j_{2n} = M$, $k_1 + \dots + k_{2n} = N$, $l_1 + \dots + l_{2n} = R$, $\sum_{p=1}^n (i_p - i_{n+p} + j_p - j_{n+p} + k_p - k_{n+p} + l_p - l_{n+p}) \sigma_p = 0$ for all $(i_1, \dots, i_{2n}, j_1, \dots, j_{2n}, k_1, \dots, k_{2n}, l_1, \dots, l_{2n})$ summations. At the same time, define

$$\begin{aligned}
&\{\Sigma(L_1, M_1, N_1, R_1) + \Sigma(L_2, M_2, N_2, R_2)\} f_{i_1, \dots, i_{2n}} \\
&\equiv \Sigma(L_1, M_1, N_1, R_1) f_{i_1, \dots, i_{2n}} + \Sigma(L_2, M_2, N_2, R_2) f_{i_1, \dots, i_{2n}}
\end{aligned}$$

Denote

$$\begin{aligned}
F_{i_1, \dots, i_{2n}}^{(a)} &\equiv F_{i_1, \dots, i_{2n}; j_1, \dots, j_{2n}; k_1, \dots, k_{2n}; l_1, \dots, l_{2n}}^{(a)} \\
&\equiv n_1^a e^{-i \sum_{p=1}^n [(i_p - i_{n+p}) \xi_p + (j_p - j_{n+p}) \eta_p + (k_p - k_{n+p}) \theta_p + (l_p - l_{n+p}) (\phi_p + 90^\circ)]} \\
&\cdot \prod_{p=1}^n \frac{\tilde{U}_p^{i_p + i_{n+p}} \tilde{V}_p^{j_p + j_{n+p}} \tilde{H}_p^{k_p + k_{n+p}} \tilde{\Phi}_p^{l_p + l_{n+p}}}{i_p! i_{n+p}! j_p! j_{n+p}! k_p! k_{n+p}! l_p! l_{n+p}!} \\
&+ n_2^a e^{-i \sum_{p=1}^n [(i_p - i_{n+p}) \eta_p + (j_p - i_{n+p}) \xi_p + (k_p - k_{n+p}) \theta_p + (l_p - l_{n+p}) \phi_p]} \\
&\cdot \prod_{p=1}^n \frac{\tilde{V}_p^{i_p + i_{n+p}} \tilde{U}_p^{j_p + j_{n+p}} \tilde{H}_p^{k_p + k_{n+p}} \tilde{\Phi}_p^{l_p + l_{n+p}}}{i_p! i_{n+p}! j_p! j_{n+p}! k_p! k_{n+p}! l_p! l_{n+p}!}
\end{aligned}$$

When $\alpha = 0$, the above formulae represent the function inside region S. When $\alpha = 1$, they represent the function on the boundary of region S. n_1 and n_2 are the x and y components of the unit vectors normal to boundary. We can get the formulae expressions for \mathcal{D} , \mathcal{E} , \mathcal{P} , \mathcal{G} :

$$\begin{aligned} \mathcal{D} = & 2A_0^{1/2} \sum (2, 0, 0, 0) F_{i_1 \dots i_{2n}}^{(0)} \\ & + 2A_0^{1/2} \sum_{k=1}^{\infty} \sum_{l=0}^k \sum_{r=0}^l (-1)^l \frac{\frac{1}{2} \left(\frac{1}{2} - 1\right) \dots \left(\frac{1}{2} - k + 1\right) (2r)! (2l - 2r)!}{A_0^l (k-l)! (l-r)! r!} \\ & \cdot \sum (2r, 2(l-r), 2, 0) \cdot \left\{ e^{-i \sum_{p=1}^n [(i_p - i_{n+p} + k_p - k_{n+p}) \xi_p + (i_p - i_{n+p}) \eta_p]} \right. \\ & \cdot \prod_{p=1}^n \frac{\tilde{U}_p^{i_p + i_{n+p} + k_p + k_{n+p}} \tilde{V}_p^{i_p + i_{n+p}}}{i_p! i_{n+p}! j_p! j_{n+p}! k_p! k_{n+p}!} + e^{-i \sum_{p=1}^n [(i_p - i_{n+p}) \xi_p + (i_p - i_{n+p} + k_p - k_{n+p}) \eta_p]} \\ & \cdot \left. \prod_{p=1}^n \frac{\tilde{U}_p^{i_p + i_{n+p}} \tilde{V}_p^{i_p + i_{n+p} + k_p + k_{n+p}}}{i_p! i_{n+p}! j_p! j_{n+p}! k_p! k_{n+p}!} \right\} \end{aligned} \quad (5.6)$$

$$\begin{aligned} \mathcal{E} = & \{3h \sum (3, 0, 0, 0) + 3 \sum (3, 0, 1, 0) + g \sum (1, 0, 2, 0) \\ & + h \sum (1, 2, 0, 0) + \sum (1, 2, 1, 0)\} \cdot F_{i_1 \dots i_{2n}}^{(0)} \end{aligned} \quad (5.7)$$

$$\mathcal{P} = \{2 \sum (1, 0, 2, 0) + 2h \sum (1, 0, 1, 0)\} \cdot F_{i_1 \dots i_{2n}}^{(0)} \quad (5.8)$$

$$\mathcal{G} = \{h \sum (1, 0, 0, 1) + \sum (1, 0, 1, 1)\} \cdot F_{i_1 \dots i_{2n}}^{(0)} \quad (5.9)$$

From formulae (5.6)-(5.9) above we can obtain a formula expression for the drag coefficient.

$$C_D = \frac{-\int_L \mathcal{E} dl - \int_L \frac{1}{2} g \mathcal{P} dl + \iint_S g \mathcal{G} ds}{\iint_S \mathcal{D} ds} \quad (5.10)$$

In the actual computations we used the three tidal components M_2 , O_1 , and K_1 at 82 stations in the Bohai Sea (see Figure 2) to get the numerical values of the various terms in formula (5.10) as shown in Table 3.

Finally, we obtained the drag coefficient C_D of the Bohai Sea to be

$$C_D = 0.0013$$

From Table 3 we see that the major energy source for the Bohai Sea is the pressure action at the open boundary. The gravitational tidal force action is smaller by an order of magnitude. That is, $g \iint_S \mathcal{G} ds$ is only one-twelfth of $-\frac{1}{2} g \int_L \mathcal{P} dl$. Thus the Bohai Sea primarily possesses properties of harmonic tides.

That the result we obtained is smaller than Proudman's result of $C_D = 0.0026$ is due to the coarseness of the sea bottom.

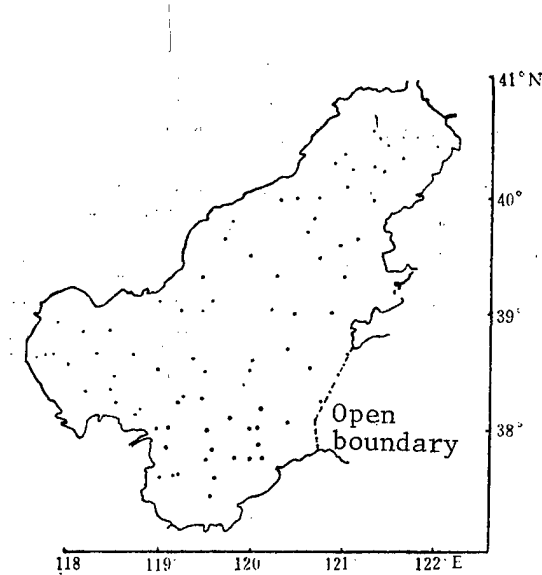

Figure 2. Bohai Sea Station Map

Table 3. Actual Computed Values of Various Terms in Formula (5.10)

$\iint_S \varphi ds(m^2/s^2)$	$g \iint_S \varphi ds(m^2/s^2)$	$-\int_L \varphi dl(m^2/s^2)$	$-\frac{1}{2} g \int_L \varphi dl(m^2/s^2)$
3.77×10^9	3.74×10^9	9.17×10^4	4.49×10^6

This paper was written based on the essay of graduate student Zhou Meng [0719 2603]. Professor Mao Hanli [3029 3352 4409] gave enthusiastic guidance to the work while high level engineer Zheng Wenzhan [6774 2429 2182] and Assistant Professor Chen Zongyong [7115 1350 6978] provided valuable suggestions. We are grateful for their help.

REFERENCES

1. Fang Guohong [2455 0948 3163], 1980. "Nonlinearity Effects of Tidal Friction (I)," HAIYANG YU HUZHAO [OCEANOLOGIA ET LIMNOLOGIA SINICA], 11(2): 98-107.
2. Fang Guohong, 1981. "Nonlinearity Effects of Tidal Friction (II)," HAIYANG YU HUZHAO [OCEANOLOGIA ET LIMNOLOGIA SINICA], 12(3): 195-209.
3. Proudman, 1953. Dynamics of Oceanography (Mao Hanli [3029 3352 4409] trans. 1956). Science Publishers, pp 329-330.

4. Dronkers, J.J., 1962. "The Linearization of the Quadratic Resistance Term in the Equation of Motion for a Pure Harmonic Tide in a Sea," Proc. Symposium Mathematical Hydrodyn. Method Phys. Oceanography, Hamburg, pp 195-209.
5. Dronkers, J.J., 1964. "Tidal Computations in Rivers and Coastal Waters," North Houard Publishing Co., 518 pp.
6. Garrett, G., 1975. "Tides in Gulfs," Deep Sea Res., 22(1): 23-35.
7. Hunter, J.R., 1975. "A Note on Quadratic Friction in the Presence of Tides," Estuar. Coast. Mar. Sci., 3: 473-475.
8. Le Provost, C., 1973. "Decomposition Spectrale du Term Quadratique de Frottement dans les Equations des Marees Littorales," C. R. Acad. Sci. Paris, pp 276, 571-574; 653-656.
9. Snyder, R.L., M. Sidjabat, and J.H. Filloux, 1979. "A Study of Tides, Setup, and Bottom Friction in a Shallow Semi-Enclosed Basin. Part II: Tidal Model and Comparison With Data," J. Phys. Ocean., 9(1): 170-188.
10. Taylor, G.I., 1919. "Tidal Friction in the Irish Sea," Phil. Trans. Roy. Soc., A220: 1-93.
11. Pingree, R.D., 1983. "Spring Tides and Quadratic Friction," Deep-Sea Res., 30: 929-944.

12966/6091

CSO: 4008/1060

END