

131097

JPRS-CST-88-005
22 MARCH 1988



**FOREIGN
BROADCAST
INFORMATION
SERVICE**

JPRS Report

Science & Technology

China

DTIC QUALITY INSPECTED 2

DISTRIBUTION STATEMENT A

Approved for public release;
Distribution Unlimited

Reproduced From
Best Available Copy

19990113 053

REPRODUCED BY
U.S. DEPARTMENT OF COMMERCE
NATIONAL TECHNICAL
INFORMATION SERVICE
SPRINGFIELD, VA 22161

10
40
A03

Science & Technology China

JPRS-CST-88-005

CONTENTS

22 MARCH 1988

APPLIED SCIENCES

New Approach to Method of Characteristics in Gas Dynamics [Wang Bainian; KONGQIDONGLIXUE XUEBAO, No 4, Dec 87]	1
Sensitivity of Aircraft Stability to Cross-Coupling Derivatives, Angular Acceleration Derivatives at High Angles of Attack [He Zhidai; KONGQIDONGLIXUE XUEBAO, No 4, Dec 87]	1
Aerodynamic Characteristics of High-Lift Rotor-Type Sails [Tang Zhonggu; KONGQIDONGLIXUE XUEBAO, No 4, Dec 87]	1
Laser Velocimetry, Flow Visualization of 3-D Flow Characteristics in Separation Region With Asymmetric Sudden Expansion [Shen Xiong; KONGQIDONGLIXUE XUEBAO, No 4, Dec 87]	1
Experimental Study of Axisymmetric-Type Turbulence Generator [Shi Wangxing; KONGQIDONGLIXUE XUEBAO, No 4, Dec 87]	2
Experimental Investigation, Semiempirical Estimate of Aerodynamic Characteristics of Swept-Forward Wing at Low Speed, High Angles of Attack [Cai Qingsheng; KONGQIDONGLIXUE XUEBAO, No 4, Dec 87]	2
Satellite Successes Boost Space Research [Xu Yuanchao; CHINA DAILY, 16 Feb 88]	2
Applications of Microelectronics Technology for China's Traditional Industries [Qian Shengsan, Fan Bingquan; JISUANJI SHIJIIE, 23 Nov 87]	2
Research, Development of Stable High-Field Nb-Ti Superconducting Magnets [Jian Zhengkuan, et al.; DIWEN WULI XUEBAO, Dec 87]	5
Prototype Test of Control Rod Drive Mechanism Used in Qinshan Nuclear Power Plant [Gao Jiyun, et al.; HE DONGLI GONGCHENG, No 6, Dec 87]	12
Protective Coating for Facilities in PWR Containment [Wang Yuehua; HE DONGLI GONGCHENG, No 6, Dec 87]	12
Burnup Determination of Mass Spectrometry for Nuclear Fuels [Zhang Chunhua; HE DONGLI GONGCHENG, No 6, Dec 87]	12
Effects of Nuclear Irradiation on Calibration of New Nickel-Based Alloy Thermocouple [Wei Huixiang, et al.; HE DONGLI GONGCHENG, No 6, Dec 87]	12
Quasi-CW Actively Mode-Locked, Q-Switched Nd:YLF Oscillator [Cao Weilou, et al.; GUANGXUE XUEBAO, No 11, Nov 87]	13
Three-Plate Optical Resonant Reflectors and Their Design [He Weiming, et al.; GUANGXUE XUEBAO, No 11, Nov 87]	13
Q-Modulation, Four-Wave Mixing Effects Caused by RSA Materials in Laser Cavity [Zhang Tao, et al.; GUANGXUE XUEBAO, No 11, Nov 87]	13
Stimulated Raman Scattering in Hydrogen, Methane Mixture [Zhao Zhensheng, et al.; GUANGXUE XUEBAO, No 11, Nov 87]	13
Study of Dynamic Processes for Colliding Pulse Mode-Locking Dye Lasers [Wang Qingyue, et al.; GUANGXUE XUEBAO, No 12, Dec 87]	13
Contribution Limitation of Side-Band Sum-Frequency Processes to Laser Frequency Conversion [Qiu Zhiren, et al.; GUANGXUE XUEBAO, No 12, Dec 87]	14
Rotating Aperture Method of Speckle Photography for Dynamic Problems. I: Two-Aperture, Four-Fan-Aperture [Gu Jie, et al.; GUANGXUE XUEBAO, No 12, Dec 87]	14
Magneto-Optical Bistability [Dong Xiaoyi, et al.; GUANGXUE XUEBAO, No 12, Dec 87]	14
Dynamics Analyses of NH ₃ Multiphoton Ionization, Fragmentation [Li Shutao, et al.; GUANGXUE XUEBAO, No 12, Dec 87]	14
Method of Inspection of Optical Synthetic Aperture Radar Processor [Jin You; GUANGXUE XUEBAO, No 12, Dec 87]	14
Light Propagation in Active Fibers [Wen Tingdun, et al.; GUANGXUE XUEBAO, No 12, Dec 87]	15
Error Analysis for Ring-Laser Weak Magnetic Field Sensor [Zhang Shulian, et al.; GUANGXUE XUEBAO, No 12, Dec 87]	15
Breakdown Condition in Tokamak [Yang Shicai, et al.; WULI XUEBAO, No 11, Nov 87]	15
Bulk, Interface Defects in Electron Irradiated InP [Peng Cheng, et al.; WULI XUEBAO, No 11, Nov 87]	15
Infrared Absorption of Doped Silicon Passivated by Atomic Hydrogen, Deuterium, Implanted by Proton [Du Yongchang, et al.; WULI XUEBAO, No 11, Nov 87]	16

A New Threshold Voltage Model for the Nonuniform Doping Small Size MOSFETs for VLSI CAD [Wang Jianwei, Ruan Gang; BANDAOTI XUEBAO, No 6, Nov 87]	16
Characterization and Modeling of LDD [Lightly Doped Drain] MOSFETs [Xie Liansheng, et al.; BANDAOTI XUEBAO, No 6, Nov 87]	16
Measurements of Reflectivity for Perfect or Nearly-Perfect Crystals Using Dispersive Double-Crystal Diffractometry [Chen Jingyi, et al.; BANDAOTI XUEBAO, No 6, Nov 87]	16
A New Explanation for the Dependence of the Pinning Position of Fermi Level on the Composition of GaAs (100) Surface [Zhang Xiangjiu; BANDAOTI XUEBAO, No 6, Nov 87]	16
Relationship Between Quasi-cylindrical Approximation, Critical Classification for Swirling Flow [Shi Xungang, et al.; LIXUE XUEBAO, No 6, Nov 87]	17
Theoretical Prediction of Cavitation Inception—Fuzzy Cavitation System [Xue Weixin, et al.; LIXUE XUEBAO, No 6, Nov 87]	17
Reflective Photoelasticity, Holointerferometry Applied to Stress Wave Propagation [Tong Jingwei; LIXUE XUEBAO, No 6, Nov 87]	17
Study of New Superconductor Ba-Y-Cu Oxides With High Critical Temperature T_c by Position Annihilation [Zhang Guocai, et al.; HE JISHU, No 12, Dec 87]	17
Software System for AAA Fire Control Operational [ZHONGGUO DIANZI BAO, 1 Dec 87]	19
JL-7 Radar Passes Reliability Testing [ZHONGGUO DIANZI BAO, 11 Dec 87]	20
Non-Circular Cross Section Tokamak FY-1 Experiment. I. Passive-Control Operation [Yao Lianghua, et al.; HEJUBIAN YU DENGLIZITI WULI, No 4, Dec 87]	20
Ion Temperature Measurements in HL-1 Tokamak by Charge-Exchange Method [Gan Dechange, et al.; HEJUBIAN YU DENGLIZITI WULI, No 4, Dec 87]	20
Measurement of Electron Density on HL-1 Tokamak Using HCN Laser Interferometer [Deng Zhongchao, et al.; HEJUBIAN YU DENGLIZITI WULI, No 4, Dec 87]	20
Ion Implantation Equipment LZ-50, Its Application To Modification of Material Surface Properties [Geng Man, et al.; HEJUBIAN YU DENGLIZITI WULI, No 4, Dec 87]	20
First Chinese-Made Industrial Robot Operational [Zhao Mingliang; RENMIN RIBAO, 19 Dec 87]	21
Nuclear Blast-Resistant Doors [KEJI RIBAO, 29 Dec 87]	21
Breakthrough in Superconductor Study Noted [Dong Yuqin, Liu Gang; GONGREN RIBAO, 2 Jan 88] ...	21
Harbin Polytechnical University Develops Printed-Chinese-Character Recognition System [JISUANJI SHIJI, 6 Jan 88]	21

EARTH SCIENCES

Baiyuneboite-(Ce)—A New Mineral [Fu Pingqiu; KUANGWU XUEBAO, No 4, Dec 87]	23
Crystal Structure of Baiyuneboite-(Ce) [Fu Pingqiu, et al.; KUANGWU XUEBAO, No 4, Dec 87]	23
Zincovoltaitite—A New Sulphate Mineral [Li Wanmao, et al.; KUANGWU XUEBAO, No 4, Dec 87]	23

LIFE SCIENCES

Investigation of Outbreak of Epidemic Non-A, Non-B Hepatitis in Duolu Township, Luopu County, Xinjiang Autonomous Region [Wang Mingyi, Tian Xin, et al.; JIEFANGJUN YIXUE ZAZHI, No 6, Dec 87]	25
Establishing Monoclonal Anti-PreS2 Cell Line, Uses of Antibody in Detection of PreS2 Antigen [Xia Mengqi, et al.; BEIJING YIKE DAXUE XUEBAO, No 5, Oct 87]	25
Esophageal Cancer Diagnostic, Treatment Tool Developed [Liu Wei; RENMIN RIBAO, 12 Oct 87]	25
New Clues Found in Genetic Code Translation Method [Liu Lusha; GUANGMING RIBAO, 23 Oct 87]	26
Infantile Hepatitis Syndrome, Cytomegalovirus Infection [Lu Shengmin, et al.; ZHONGHUA CHUANRANBING ZAZHI, No 4, Nov 87]	26
Liver-Specific Circulating Immune Complex in Rival Hepatitis B [Liu Zuchong; ZHONGHUA CHUANRANBING ZAZHI, No 4, Nov 87]	26
Investigation of Anti-HAV, Its Changes in Acute Viral Hepatitis Serum by Double Sandwich ELISA Method [Shang Shouli, et al.; ZHONGHUA CHUANRANBING ZAZHI, No 4, Nov 87]	27
Blood Vessel Contracting Agent Isolated From Leukocytes [Liu Lusha; GUANGMING RIBAO, 18 Nov 87]	27
Research Underway to Develop Monoclonal Antibody-Secreting Hybridoma [Liu Zhengqin, Tang Guoxing; KEJI RIBAO, 13 Oct 87]	27
Fetal Liver Cell Treatment of Leukemia, Aplastic Anemia [PEOPLE'S DAILY, 17 Dec 87]	28

Establishment of Filler-Cell Free Single T Cell Culture System With High Cloning Efficiency [Chen Weifeng, K. Shortman; ZHONGHUA WEISHENGWUXUE HE MIANYIXUE ZAZHI, No 6, Dec 87]	28
Study of Gene for Membrane Protein of Enterobacteria. III. New Lipoprotein Gene of Escherichia Coli [Huang Yaoxuan, et al.; ZHONGHUA WEISHENGWUXUE HE MIANYIXUE ZAZHI, No 6, Dec 87] ..	28
Bivalent Strain With Characteristics of Shigella Flexneri 2a, Sonnei [Wang Bingrui, et al.; ZHONGHUA WEISHENGWUXUE HE MIANYIXUE ZAZHI, No 6, Dec 87]	29
Studies of Meningococcal Polysaccharide-Tetanus Toxoid Conjugates [Guo Yuyi, et al.; ZHONGHUA WEISHENGWUXUE HE MIANYIXUE ZAZHI, No 6, Dec 87]	29
Studies of Kinetics of Protein Synthesis Inhibition in Targeting Cells by Immunotoxin [Shen Beifen, et al.; ZHONGHUA WEISHENGWUXUE HE MIANYIXUE ZAZHI, No 6, Dec 87]	29
Prevention of Perinatally Transmitted Hepatitis B Virus Infections With Hepatitis B Immunoglobulin, Hepatitis B Vaccine [Kang Yong, et al.; ZHONGHUA WEISHENGWUXUE HE MIANYIXUE ZAZHI, No 6, Dec 87]	30
Study of Relationship Between Gamasid Mites, Epidemic Hemorrhagic Fever [Wu Guanghua, et al.; ZHONGHUA LIUXINGBINGXUE ZAZHI, No 6, Dec 87]	30
Experimental Study of Biting, Transstadial, Transovarian Transmission of Epidemic Hemorrhagic Fever Virus by Gamasid Mite Ornithonyssus Bacoti [Zhuge Hongxiang, et al.; ZHONGHUA LIUXINGBINGXUE ZAZHI, No 6, Dec 87]	30
Antimicrobial Resistance of S. Typhi, Outbreak of Typhoid Fever [Zheng Qingsi, et al.; ZHONGHUA LIUXINGBINGXUE ZAZHI, No 6, Dec 87]	31
Survey of Clinical, Epidemiological Characteristics of Plesiomonas Shigelloides Infection [Xu Xingqiang, et al.; ZHONGHUA LIUXINGBINGXUE ZAZHI, No 6, Dec 87]	31
Comparison of RPHI With McAbs, HI in Diagnosis of Japanese Encephalitis [Zheng Xiwen, et al; ZHONGHUA LIUXINGBINGXUE ZAZHI, No 6, Dec 87]	31
Comparison of Different Micro-Blood Sampling Methods in Indirect Fluorescent Antibody Test for Malaria [Huang Wenzhou, et al.; ZHONGHUA LIUXINGBINGXUE ZAZHI, No 6, Dec 87]	31
Laser-Induced Cell Fusion Technique Successfully Tested [Ke Yan; KEJI RIBAO, 4 Dec 87]	32

NATIONAL DEVELOPMENTS

Rare-Earth Magnet Products Find Ready World Market [KEJI RIBAO, 1 Dec 87]	33
Ten Major Events of 1987 in Chinese Computer World [JISUANJI SHIJIE, 6 Jan 88]	33
China's Information Industry Develops Rapidly in 1987, But Enormous Gaps Still Exist [JISUANJI SHIJIE, 6 Jan 88]	33

SCIENTISTS, SCIENTIFIC ORGANIZATIONS

Zhejiang University Completes High-Purity Silicon, Silane Lab [Lu An; RENMIN RIBAO, 18 Nov 87] ...	35
Key State Surface-Physics Lab Operational [Meng Yangjie; RENMIN RIBAO, 22 Nov 87]	35

New Approach to Method of Characteristics in Gas Dynamics

40090048a Mianyang KONGQIDONGLIXUE
XUEBAO [ACTA AERODYNAMICA SINICA] in
Chinese Vol 5 No 4, Dec 87 pp 311-317

[English abstract of article by Wang Bainian [3769 0184 1628] of Shanghai Institute of Mechanical Engineering; J.D. Hoffman of Purdue University]

[Text] In this work, two basic concepts of motion in the flow field, i.e. particle motion and weak wave motion (the motion of small disturbances), and their mathematical relationships concerning the material derivative and the wave derivative are used as the basis of the method of characteristics. From this new approach, some new results are obtained. Specifically, the vector form of the compatibility equation for unsteady, three-dimensional, viscous flow along the wave lines is derived first. This vector form of compatibility equations is valid for any coordinate system. Compared with previous approaches to the method of characteristics, the physical concept and the mathematical procedure are clearer and simpler than before. Finally, some problems concerning the application of basic equations of the method of characteristics to set up a numerical solution are presented.

9717/12232

Sensitivity of Aircraft Stability to Cross-Coupling Derivatives, Angular Acceleration Derivatives at High Angles of Attack

40090048b Mianyang KONGQIDONGLIXUE
XUEBAO [ACTA AERODYNAMICA SINICA] in
Chinese Vol 5 No 4, Dec 87 pp 334-344

[English abstract of article by He Zhidai [0149 2784 1486] of Northwestern Polytechnic University]

[Text] For modern fighter aircraft, flight at high angles of attack is an inherent part of maneuvering. The typical modern fighter aircraft achieves maximum lift at angles of attack from approximately 25 to 35 degrees. Aggressive maneuvering can cause pitch overshoots and angles of attack transient to 60 degrees and, therefore, are subjected to conditions in which the flow becomes highly asymmetric. Under such flight conditions and maneuvers, certain cross-coupling derivatives, negligible under low angle-of-attack flight conditions, become large enough to be considered.

In this paper, the author tries to ascertain whether the inclusion in the equations of motion of certain aerodynamic cross-coupling terms is important for the motion stability of a modern fighter at high angles of attack. A numerical study has been undertaken in which the sensitivity of the motion time histories to these various terms is examined using six-degree of freedom equations on a digital computer. The time histories of aircraft motion are calculated and presented graphically.

By comparing the time histories with and without the terms mentioned above, the sensitivity of the aircraft response to these terms can be observed clearly. The study indicates that some cross-coupling derivatives have marked effects which should be considered carefully in aircraft design.

9717/12232

Aerodynamic Characteristics of High-Lift Rotor-Type Sails

40090048c Mianyang KONGQIDONGLIXUE
XUEBAO [ACTA AERODYNAMICA SINICA] in
Chinese Vol 5 No 4, Dec 87 pp 359-365

[English abstract of article by Tang Zhonggu [3282 1813 6253], et al., of Wuhan University of Water Transportation Engineering]

[Text] This paper presents the aerodynamic characteristics of rotor-type sails. The experimental results show that the lift coefficient and thrust coefficient of rotor-type sails can be a few times greater than those of the conventional rigid sail of the circular arc-type, and the best aerodynamic performance is achieved with the rotational-belt sail.

The rotational-belt sail is simulated numerically using a new version of the velocity vortex method. This method provides an effective prediction of flows involving a rounding tail and rotating wall.

9717/12232

Laser Velocimetry, Flow Visualization of 3-D Flow Characteristics in Separation Region With Asymmetric Sudden Expansion

40090048d Mianyang KONGQIDONGLIXUE
XUEBAO [ACTA AERODYNAMICA SINICA] in
Chinese Vol 5 No 4, Dec 87 pp 366-373

[English abstract of article by Shen Xiong [3088 3574] of Qinghua University, Beijing]

[Text] Three velocity components of the turbulent separation region downstream of the backward facing step in a two-dimensional duct have been measured using a dual-differential frequency shift LDV system. The flow model has a step height of 20 mm, with an expansion ratio of 2:1 and aspect ratio of 3:2. The experimental Reynolds number is 5700. The results show the shape of a three-dimensional separation region and demonstrate a pair of transverse vortices existing in the region just behind the step. The reattachment length is the longest in the central plane, decreasing gradually in the planes close to the side wall. Photographs obtained by laser visualization show that the flow patterns are in agreement with the LDV measurements.

9717/12232

Experimental Study of Axisymmetric-Type Turbulence Generator

40090048e Mianyang *KONGQIDONGLIXUE XUEBAO* [*ACTA AERODYNAMICA SINICA*] in Chinese Vol 5 No 4, Dec 87 pp 390-396

[English abstract of article by Shi Wangxing [2457 4986 5281] of Nanjing Aeronautical Institute]

[Text] The influences of the Mach number before the shock wave, the area ration and the relative length upon the distortion field are discussed. Since the Mach number before the shock wave has a larger influence on the steady state and dynamic distortion factors, it is a major parameter regulating the distortion field.

The analyses of the distortion patterns show that the distortion field is unsteady, since a low pressure area would migrate circularly to various clock positions. In moving, it would change in size and shape, which is reflected in the distortion factor. This unsteady characteristic reduces the repeatability and predictability of the distortion factors.

9717/12232

Experimental Investigation, Semiempirical Estimate of Aerodynamic Characteristics of Swept-Forward Wing at Low Speed, High Angles of Attack

40090048f Mianyang *KONGQIDONGLIXUE XUEBAO* [*ACTA AERODYNAMICA SINICA*] in Chinese Vol 5 No 4, Dec 87 pp 409-412

[English abstract of article by Cai Qingsheng [5591 1987 3932] of Beijing Institute of Aeronautics and Astronautics]

[Text] An investigation of the aerodynamic characteristics of SFW (swept-forward wings) at high angles of attack has been made using force measurements, pressure distribution measurements on wing surfaces and flow visualizations. A semiempirical method has also been established based on the investigation for calculating the lift of SFW with partial wing stall.

9717/12232

Satellite Successes Boost Space Research
HK160316 Beijing CHINA DAILY in English
16 Feb 88 p 1

[By staff reporter Xu Yuanchao]

[Excerpts] After successfully launching 21 satellites, China is concentrating on hi-tech space research involving permanent space stations, space transportation systems, and related technology, a leading official said yesterday.

Sun Jiadong, Deputy Minister of the Astronautics Industry, however, told CHINA DAILY that China's space programme "is still at a preliminary stage."

"We just have tentative plans. Details of whether we use a spaceship or a space shuttle in a space transportation system have not been hammered out. The proposed space programme depends to a large extent on technology and finance," Sun said.

Between 1975 and 1987 China launched 10 retrievable satellites. The recovery rate was 100 percent.

Since the 1970s, China has launched 21 satellites, including eight science and technology experimental models and three communications broadcasting satellites, Sun said.

Satellite remote sensing has been widely applied to geological surveys, oil exploitation, water conservation, agriculture, land management, environment monitoring, railway line selection, and earthquake and natural disaster forecasting.

Long-range transmission by satellite has been used for long-distance communication, broadcasting, television, and military purposes. All this indicates that China now ranks among the world's most advanced nations in satellite technology, Sun said.

Chinese research scientists have mastered complicated technology for satellite recovery, multi-satellite launching and satellite positioning.

China has developed three types of carrier rocket which are able to launch heavy satellites which orbit close to the earth and other satellites in geostationary orbits.

The country has two satellite launching centres in Jiuguan in Gansu Province and Xichang in Sichuan Province, as well as a nationwide ground observation network centered on the satellite monitoring station in Weinan in Shaanxi Province.

Applications of Microelectronics Technology for China's Traditional Industries

40080046a Beijing *JISUANJI SHIJIE* in Chinese
23 Nov 87 pp 34-35

[Article by Qian Shengsan [6929 4164 0005] and Fan Bingquan [5400 3521 0356]: "An Analysis of the Situation Regarding the Application of Microelectronics Technologies in Chinese Traditional Industries"]

[Excerpts] I. A look at statistical analyses shows that the level of applications of microelectronics has become an important indicator of the modernization process in traditional industry.

In recent years, with the growth of applications of microelectronics for traditional Chinese industries, enormous changes have occurred in the internal traditional equipment structures, personnel structures, output value structures, and information processing structures within enterprises. These changes are continuing and they will inevitably lead to profound changes in enterprise production forces, having a great affect on changes in overall traditional industrial structures.

With that in mind, from an overall viewpoint, how are we to describe the situation regarding the application of microelectronics within enterprises, industries, and even all traditional industries?

An investigation at the production unit level shows that we can use these four indicators: 1. The component of microelectronics equipment within the original value of the fixed assets; 2. The proportion of technical personnel used by microelectronics in relation to the total labor force; 3. The proportion of the output value relevant to the applied microelectronics technologies in relation to the gross industrial output value; and 4. The proportion

goal/data/unit
component of microelectronics equipment in fixed assets
proportion of microelectronics application technical personnel among total labor
proportion of output value relating to the applied microelectronics within gross industrial output value
labor productivity for all personnel

of the amount of information collected, processed, and stored by microelectronics technologies in relation to the total amount of information processed.

A survey and analysis of some enterprises that import microelectronics technologies (for example, the Baogang and Guangzhou Main Petrochemical Plants) shows that among enterprises that represent a level of technology equivalent to that abroad in the late 1970's and early 1980's, the application of microelectronics is quite common. The microelectronics equipment within the original value of fixed assets is very high: 20 percent or more, and the output value relating to applied microelectronics as part of gross industrial output is at 50 percent or more.

By a cross-sectional analysis, we can see that in enterprises where the degree of application differs, the values for the indicators change only slightly for the different industries. Generally speaking, they expand with the scale of application, and are in a state of continuing synchronous growth. This dynamic change deeply reflects the conclusion that "the application of microelectronics in traditional industries is certain to lead to a series of changes in production forces."

The following table uses four enterprises in the metallurgy industry to illustrate the problems just described:

	Plant A	Plant B	Plant C	Plant D
component of microelectronics equipment in fixed assets	0.80%	1.47%	26.1%	25.1%
proportion of microelectronics application technical personnel among total labor	0.30%	0.86%	1.83%	2.84%
proportion of output value relating to the applied microelectronics within gross industrial output value	10.10%	17.04%	30.00%	98.00%
labor productivity for all personnel	21,900 yuan per person per year	22,100 yuan per person per year	32,000 yuan per person per year	—

The data in the table dynamically reflects the differing degrees of the application of microelectronics technologies, as well as the fact that the economic results therefrom are also not identical; this also shows clearly that as the level of applications of microelectronics technologies expands, traditional industries are just now gradually becoming industries that are three-way intensive: in technology, knowledge, and finances. This data also tells us that the application of microelectronics develops in stages. When about 10 percent of the output value of an enterprise is related to the application of microelectronics technologies, microelectronics applications have reached the breakthrough threshold; when this ratio reaches 30 percent, the enterprise has reached the stage where traditional management and traditional modes of production have been challenged by modern management and modes of production; and when that ratio reaches 50 percent, the enterprise has reached the point at which it is no longer possible to do without microelectronics technologies.

Currently, according to a study of applications of microelectronics in some of China's large and medium size enterprises, it can generally be said that applications of

microelectronics technologies are still at the breakthrough threshold. The average component of fixed assets represented by microelectronics equipment is 3 percent; microelectronics applications personnel are 0.54 percent of the total number of workers; and 15 percent of the gross industrial output is related to applied microelectronics technologies. This shows that the level at which microelectronics technologies is being applied in China's traditional industries is still quite small, and there is a rather large gap between this level and that of technology abroad in the late 1970's and early 1980's.

To allow China's traditional industries to achieve by the year 2000 the level of technology present abroad in the late 1970's and early 1980's, we want for the most part to achieve or approach the standards of industries currently being imported in terms of the status indicators of several microelectronics technologies applications. According to a preliminary calculation, by the year 2000, microelectronics equipment should be worth at least 200 billion yuan in the industrial fixed assets of China, and microelectronics applications personnel should number at least 2 million. This is an enormous investment of

finances and personnel, and one that this country possibly cannot manage. Therefore, to attain this goal we must concentrate on key areas, industries, and enterprises that can bring overall changes to traditional industries. This will allow them to first achieve the level of applications equal to that abroad in the late 1970's and early 1980's, after which the foundation formed by these enterprises will stimulate applications of microelectronics in other regions and in other small to medium size enterprises.

II. The growth of the level of these applications of microelectronics to traditional industries will depend upon an improvement in the ability of traditional enterprises to absorb microelectronics technologies.

This means that the degree to which microelectronics equipment is put into operation will lead to changes in production forces within the enterprise. Applications of microelectronics technologies should not "instigate mass actions," but should be such that enterprises can promote growth according to their own capacities.

What factors are concerned with the capacity of an enterprise to absorb microelectronics? After a relational analysis of the level of several hundred microelectronics applications in industries to empirical indices from these enterprises, we reached the following conclusions: first, the level of microelectronics applications within an enterprise and the scale of the enterprise itself (fixed assets, gross industrial output value) are, generally speaking, somewhat the same. Second, the more microelectronics applications personnel employed, the greater the scale of applications. Because some larger enterprises lack skilled personnel, their scale of application is not correspondingly large. Third, the level of the application of microelectronics technologies is related to the labor productivity of an enterprise, and generally speaking, enterprises that have done well at application have a higher labor productivity than average.

The relational analysis we have just described shows that the capacity of an enterprise to absorb microelectronics technologies is primarily apparent in aspects such as the scale of an enterprise, the number and quality of personnel applying the microelectronics, and the rate of growth for labor productivity in the enterprise. Naturally, the capacity for the absorption of applications is also related to the nature of processing at the enterprise and to the level of management.

The relational analysis also shows that, generally speaking, for enterprises in the early stages of application, their labor productivity should not be lower than 10,000 yuan per person per year; when labor productivity runs from 15,000 yuan to 20,000 yuan per person per year, that enterprise should be entering a stage of more rapid development; the amount of microelectronics equipment possessed by an enterprise on a per capita basis for

applications personnel should not generally exceed 40-50,000 yuan. At the early stage of application, the component of microelectronics equipment among fixed assets should not exceed 5 percent.

In addition to this, it has been discovered by subjecting the direct economic results gained from the application of microelectronics to a quantitative analysis (establishing a measurement model) that the size of the economic results is intimately related to the absorptive capacity of the enterprise, and that it is not necessarily the case that economic results are greater for enterprises having greater quantities of microelectronics applications. The analysis further shows that from an overall point of view, there is a curve for economic results that applies to enterprises applying microelectronics technologies. When a relatively small amount of microelectronics equipment is put into production, the results are also small; when the amount of microelectronics equipment is excessive, the economic results will tend to decline; only when the quantities put into production are equivalent to from 1 to 5 percent of the gross value of the fixed assets of an enterprise (this value will differ for different industries) will the economic results be better. This piece of data fundamentally coincides with the above conclusion obtained from the relational analysis of applications scales.

III. Improvements for the economic scale of microelectronics applications in traditional industries and for the capacity of an enterprise to absorb microelectronics applications.

There is a definite economic relation between investment expended in applying a new technology (as determined by pricing factors), and the production output of the enterprise in which this technology is applied (for applications within the scope of over-large production quantities).

In 1974, an American economist Luodaceng [phonetic] studied the economic rules for the application of computers in the United States since the 1950's. He proposed the so-called "one percent" rule, that is, "if the production capacity (output value) of a process is so many dollars, then to improve the computer investment in this process that investment should not be more than one percent of that output value."

The "one percent" rule means that in the application of microelectronics technology, attention should be paid to the economically reasonable deployment of microelectronics products (equipment) together with the scales of production processes. The relation of scale of application to the scale of enterprise as proposed in our relational analysis above is actually a reflection of this "one percent" rule in the traditional industries of China, and it also points out the path for the expansion of the level of microelectronics applications in enterprises.

If we are to improve the capacity for absorption and the scale of applications by enterprises, in addition to greater attention by leadership and the improvement of management, the right conditions must be met within the following three areas. First of all, we must continue to bring down the prices of the products of microelectronics technologies, which will allow microelectronics products to gradually enter production processes of a smaller scale, thereby progressively expanding the scope of applications. Second, enterprises should energetically improve their own application environments, and should plan in any way possible to train applications technical personnel. Our study has shown that 50 percent of microelectronics applications personnel are technical personnel from non-electronics majors who have "changed fields," and that the proportion of these from the mechanical professions are higher still at 60 percent. This explains that skilled microelectronics applications personnel are not necessarily computer specialists, and that it is more necessary that they have composite skills integrating the various specialties of mechanics, chemical engineering, and metallurgy. If enterprises pay attention to the training of this kind of composite talent, it will be certain to aid in improving the capacity of enterprises to absorb microelectronics applications. Third, enterprises must link together the goals of microelectronics applications with improving enterprise quality, with improving the capacity of products to compete, and with an expansion of market share. They must especially actively strive to compete internationally, to expand their scales of production, to improve their production forces, to improve labor productivity, and to reinvest the economic results. In fact, the goals of the highest stage in the application of microelectronics by enterprises abroad is to improve their capacity for international competition and to expand their market share, which is much more far-reaching than the significance of saving on some raw materials through staying at the stage of low-level applications.

IV. Sustained growth for microelectronics in traditional industries will require that we hasten the growth of China's microelectronics industry, as well as that microelectronics technologies be made Chinese.

Statistical data shows that during the period of the "6th Five Year Plan," more than 50 percent of the microelectronics equipment applied in China's traditional industries came from abroad. We must break from applications of this nature that chiefly rely upon imports. First of all, this is because we cannot submissively turn over this large a market to foreigners. Second, for several years now every enterprise that has imported things has experienced shortages of parts, and with the current lack of foreign exchange, some equipment that has been damaged cannot be repaired. It is even true that some large-scale importing enterprises have come up with the idea of manufacturing their own relevant parts, all of which goes to show that the problem of making the production of microelectronics equipment Chinese is

urgently at hand, and that it even affects the great question of whether microelectronics applications in the traditional industries of China can continue to develop in depth.

Therefore, we should do key studies in a planned and concentrated way of general or widely-used specialized microelectronics applications; with our goals in mind, we should organize three-way cooperation between whole-machine equipment manufacturing plants, component parts manufacturing plants, and application units. There should be jointly designed Chinese-made products, and microelectronics applications devices should be manufactured as quickly as possible that have Chinese characteristics, that are suitable for dissemination, and that are attractive in both price and aspect. These will seize the markets, and can even be extended to the international marketplace.

12586

Research, Development of Stable High-Field Nb-Ti Superconducting Magnets

40080039 Beijing DIWEN WULI XUEBAO [CHINESE JOURNAL OF LOW TEMPERATURE PHYSICS] in Chinese Vol 9, No 4, Dec 87 pp 316-324

[Article by Jian Zhengkuan [3542 2973 1401] et al. of the Institute of Plasma Physics, Chinese Academy of Sciences, Hefei; manuscript received 27 April 1986: "Research and Development of Stable High-Field Nb-Ti Superconducting Magnets"]

[Text] Abstract: This paper discusses the disturbance spectrum of an adiabatic superconducting magnet and analyzes the key steps in winding a stable high field Nb-Ti magnet. Six experimental superconducting magnets have been wound with Chinese-made multi-filament Nb-Ti wire by a wax brushing technique with Al_2O_3 or Gd_2O_3 powder added to it. The central fields produced by these magnets are all greater than 8.5 T. The maximum is 9.24 T. The quench current is above 95 percent of the load on the short sample. In most cases, there is no training behavior.

The magnet can be excited to high fields at a high rate. Typically, it rises to 8.0 - 8.5 T within 1.5 - 2.0 minutes without quenching. After more than 10 quenches and 8 heat-cool cycles, it can still operate stably at 8.6 T. This proves that this technique is effective.

1. Introduction

The current superconductor technology is most widely used to make medium and small size superconducting magnets in the laboratory.

The performance of the superconducting material Nb-Ti made in China and its associated technology have developed to a reasonable level. For example, the values of J_c (4.2K, 5T), are 2.0 - 3.0 x $10^5 A \cdot cm^{-2}$ and 4.0 x

$10^5 \text{A} \cdot \text{cm}^{-2}$ at the production level and research level, respectively. They are equivalent to comparable products in the rest of the world. In comparison, there is still quite a difference in the superconducting magnet technology between China and the rest of the world. This is primarily shown in the following areas:

- (1) the lack of a stable high field (greater than or equal to 8T) Nb-Ti magnet;
- (2) low permissible excitation rate;
- (3) difficulty in sustaining long term (continuous or cycling) operation, or multiple quench tests.

Since the specific heat C of the alloy wire used for winding the magnet drops abruptly to $1.5 \times 10^3 \text{J} \cdot \text{m}^{-3} \cdot \text{K}^{-1}$ around 4.2K, a $1 \mu\text{m}$ slip will cause a temperature rise of the order of 1K. On the other hand, the superconducting critical current density is extremely temperature sensitive. In an adiabatic superconducting magnet, the temperature tolerance is only 0.1K. Correspondingly, the energy to trigger a quench is of the order of 0.1 - 1 mJ.

Based on the above discussion, movement of the wire even to the micron level is not allowed. Therefore, the basis for making a stable adiabatic magnet is to prevent the macroscopic and microscopic movement of the wire and the magnet.

2. Key Techniques in Magnet Fabrication

(a) Selection of Soaking Materials

There are two major classes of soaking materials:

(1) High elastic modulus agents such as epoxy resin. The advantage is that the strength of the entire structure is high. It has been successfully placed in magnetic dipole and quadripole systems in an accelerator. However, epoxy becomes brittle at low temperature, and the differences in mechanical strength and thermal expansion coefficient between epoxy and copper are too large, and it peels off or cracks too easily under electromagnetic force and thermal stress. Because of its high Young's modulus, epoxy stores a great deal of elasticity. A large thermal pulse is released after its cracks open. Consequently, it is susceptible to deterioration and training effect.

(2) Low elastic modulus soaking agents. Inspired by Smith et al.,^[1] we developed a simple brushing technique using paraffin wax with alumina powder. The elastic modulus of paraffin is low. It will not trigger a quench even if shattered. Nevertheless, it can effectively prevent the conductor from moving. Alumina powder can improve the heat conductance of the magnet at low temperatures. In addition, it matches the expansion coefficient of the wax better than that of the superconducting wire. A 90 mm diameter winding of 3.5 Kg of

Nb-Ti wire was made by using this technique. It generated a maximum field of 6.5T and completely overcame the problem of deterioration and training behavior^[2]. We pointed out that the deterioration effect commonly in existence back then in China was due to mechanical instability. This technique was adopted by some organizations with satisfactory results. The addition of alumina powder not only increases the thermal conductivity of the wax but also improves the thermal expansion characteristic of the paraffin so that it matches better with that of copper. It was also experimentally discovered that adding alumina powder had a significant effect on the elimination of distribution disturbance to enhance magnetic excitation^[3].

On the other hand, when disturbance is unavoidable, the heat capacity of the winding can be raised to suppress the temperature rise of the superconducting wire in order to prevent the deterioration of the magnet.

In recent years certain rare earth oxides (such as Gd_2O_3 , GdAlO_3) and intermetallic compounds (such as PrCu_2 , PrB_6) were found to undergo a series of phase transitions in the temperature range of interest, resulting in an abnormal increase in specific heat. For instance, Gd_2O_3 is under the influence of a crystalline field splitting effect and undergoes long range ordering at low temperature. Its specific heat has a maximum at 4 - 5K. For example, the average specific heat of a copper wire with 7.2 weight percent Gd_2O_3 is $4.2 \text{mJ} \cdot \text{g}^{-1} \cdot \text{K}^{-1}$, which is 60 times higher than that of pure copper^[4].

Rosenblum, et al., proposed to diffuse Gd_2O_3 into a stable copper matrix to test its enthalpy stability. After some consideration, we concluded that diffusing Gd_2O_3 into the matrix would not only lower its RRR value but also make it more difficult to process. In addition, since the superconductor is in the form of a fine wire, internal disturbance such as magnetic flux skip is not the principal cause of deterioration. Therefore, we mixed Gd_2O_3 powder into the paraffin in order to absorb the thermal pulses generated by the movement of the wire.

Based on the above discussion, we proposed the following soaking (brushing) techniques.

Technique A: Use paraffin as the soaking agent with alumina powder (Al_2O_3) added to it. Paraffin is heated until it is melted. Add Al_2O_3 powder at a ratio of 1:2 with paraffin by volume. Alumina powder will settle to the bottom. It will require mixing. Specifically, use a heat gun to bake the coil. After winding each layer, use a brush to coat the wax uniformly over it. Allow the wax to fill the gaps and remove any excess to improve the duty cycle of the superconducting wire.

Technique B: Use paraffin as the soaking agent and add gadolinium oxide powder (Gd_2O_3) at a ratio of 1:2 by volume gadolinium oxide versus paraffin.

Technique C: For comparison, we also tested magnets made without any soaking agent. The result showed that, in terms of excitation rate and achievable high field strength, the magnets fabricated by Technique C did not differ very much from those made using Techniques A and B. However, they showed some training behavior. The stability of these magnets is inferior to those made by using Techniques A and B.

(b) Winding Stress and Overall Reinforcement

A very high current passes through a superconducting magnet at a high field. It is under a great deal of magnetic pressure ($\sigma_m = B^2/2\mu_0$), which is similar to a high pressure vessel. For example, when $B = 6$ and $10T$, σ_m becomes $1.4 \times 10^7 Nm^{-2}$ (approximately equal to 140 atm) and $4.0 \times 10^7 Nm^{-2}$ (approximately equal to 400 atm), respectively. They are equivalent to the operating pressure of a high pressure gas cylinder and the yield strength of annealed copper, respectively. The largest effect comes from the radial expansion force on the winding which results in the annual stress σ_θ on the superconductor.

Figure 1 shows the radial distribution of σ_θ and σ_r of the magnet M_1 .

Figure 1 shows that σ_θ is different at different radial position. To prevent the wire from slipping, we made appropriate adjustment according to the variation of σ_θ when we chose the winding stress.

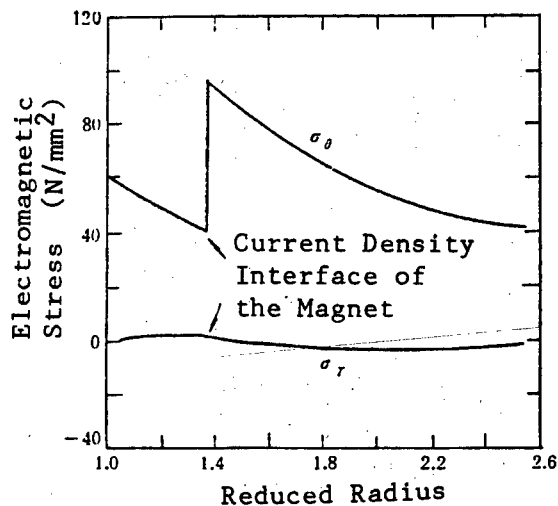

Figure 1. Radial Distribution of Sigma and Sigma on M_1

The stress effect on I_c of Nb-Ti should also be considered in the selection of the winding tension. However, only at very high stress will significant decrease in I_c occur. In addition, it is reversible.

The maximum operating stress of the Nb-Ti wire is approximately $500 MNm^{-2}$. Let us assume that the packing factor of the conductor is 0.7 and the strength of the packing material can be neglected. Then, the permissible σ_θ is approximately equal to $350 MNm^{-2}$. Let $\alpha = 1.3$, the magnetic pressure approximately equal to $81 MNm^{-2}$. The upper limit of the operating field B_{max} is approximately equal to 14T (greater than $H_{c2}(NbTi)$). Thus, only the annual stress on the thin wall coil needs to be considered.

In the above analysis, the winding stress was chosen primarily to prevent the wire from moving. We do not have to worry about the effect of stress on the superconducting property of the superconductor. In practice, we think it is appropriate to choose 8 - 10 Kg/mm² as the winding stress. In addition, under the influence of a large electromagnetic force, the coil will undergo a macroscopic elastic deformation. Therefore, a coil needs to be reinforced by a suitable material.

Usually, varnished copper wire is used for reinforcement. This is feasible for a low field (less than or equal to 7T) small coil. However, when the field was increased and the coil got larger (greater than or equal to 8T), the varnished wire was found to become loose after several quench events. The performance also deteriorated. We believe that the cause is that σ_θ already approaches the yield limit of copper when B is greater than or equal to 8T and $\alpha = 1.3$ to approximately 2.0. Consequently, the presence of anelasticity is obvious, resulting in permanent plastic deformation. Very good results were obtained by using pre-stressed stainless steel wire to reinforce the magnet. In practice, we are using four 0.3 - 0.5 mm diameter stainless steel wire layers. The stress is calculated based on 30 Kg/mm² according to the diameter of the wire.

(c) Selection of Insulating Material and Improvement of Packing Factor

In the past the following technique was very popular: Oxidized aluminum foil (30 - 50 gmm) was packed between layers to increase the heat dissipation capability of the winding. Dacron films (30 - 50 μm) were used to line both sides of the aluminum foil to improve the insulation strength.

This technique not only complicated the process but also caused two detrimental effects.

Based on an analysis from the angle of structural mechanics, to lay down a low strength material about 100 μm in thickness between two wire layers can easily cause microscopic movement under the effect of an electromagnetic force. In addition, the packing factor is lowered, resulting in a decline of overall current density.

In the various techniques mentioned above, only 1-2 sheets of thin ($5\ \mu\text{m}$) capacitor paper is placed between the layers to improve the packing factor from approximately 0.6 to approximately 0.75. This is a favorable measure to achieve higher field strength.

It was proven in practice that there is sufficient insulation strength at 500V.

(d) Lead Wire for Current

This is a key step that could be neglected. Because electromagnetic force, thermal stress and stress are concentrated, there are many instances where the lead wire is broken or damaged. The configuration we designed is shown in Figure 2. The lead is embedded in a slot inside the frame of the magnet. The lead is brought out from a circular slot and the wire is strengthened with an insulating cement. The slot is back filled with solder. Another piece of superconducting wire is welded as the lead. Thus, the lead is more rigid and there is no concern about breakage.

3. Experimental Setup

(a) Selection of Technique

One of the basic assigned tasks is to propose a feasible technique. Based on the analyses discussed above, we performed a great many experiments on the packing material, winding tension, insulation method, structural material, reinforcement method and lead arrangement.

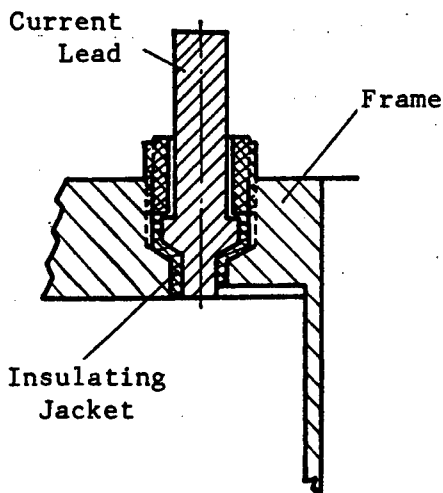

Figure 2. Current Lead Configuration

After repeated comparison, we are able to reduce them to Technique A (packed with paraffin with Al_2O_3 powder), Technique B (paraffin with Gd_2O_3 powder) and Technique C (no filler).

(b) Proof of Feasibility

A technique to be widely adopted is one that can be repeated by different people with different materials on different magnets.

To this end, we asked the Institute of Non-Ferrous Metals (primary site), Baoji Institute of Precious Metals and Shanghai Institute of Non-Ferrous Metals to produce multi-filament wires to wind six superconducting magnets. Three of them (M_I , M_{II} , M_{III}) have identical dimensions to compare these techniques. The other three were given to the Shanghai Institute of Metallurgy (M_{IV}) and Institute of Physics (M_V , M_{VI}). In addition, they were tested in actual operation based on user request. The last three magnets, sometimes were used as the background magnets in combination with the Nb_3Sn system, sometimes were required to have high uniformity, and sometimes fast back and forth excitation. Thus, the test could demonstrate whether the technique was reproducible on a small batch basis.

The magnets were wound by different people.

(c) Excitation Rate and Thermal Cycle Tests

The permissible excitation rate is an important parameter reflecting the stability of the magnet against distribution disturbance^[5]. It is also a technical specification of great concern to the users. In addition, people are also concerned about whether a high performance magnet being excited for the first time can survive heat-cool cycles, especially for a magnet packed with low strength material.

(d) Study of the Physics of the Magnet

In order to explain the behavior of magnets made by different techniques from a theoretical basis, the variations of parameters such as the minimum trigger energy, propagation speed, minimum propagation current and stable current in the normal region with current and magnetic field were measured in parallel with different winding techniques and under different cooling conditions. (The results are to be published separately^[6].)

4. Primary Experimental Results

Figures 3 and 4 show the excitation characteristics of these magnets. The following major findings are obtained.

(1) The use of either Technique A, B, or C can basically overcome the deterioration effect. All six magnets reached 95 percent of the specification for a short sample on the load line. This illustrates that these techniques are effective in overcoming the deterioration caused by mechanical movement.

(2) Training effect did not occur with magnets made by Techniques A and B. In most cases, the maximum field was reached in one excitation. The quench field strength

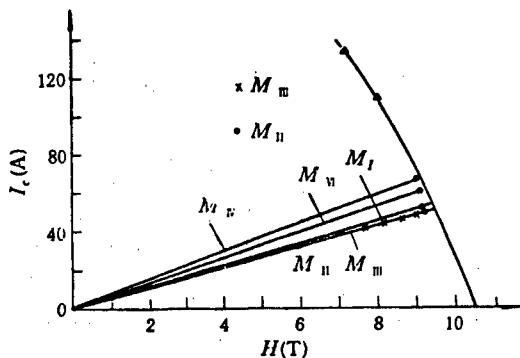

Figure 3. Excitation Characteristics of the Magnets

fluctuated somewhat from time to time, however, it did not show any increasing trend. On the contrary, the field strength of the magnet made by using Technique C varied from 7.4 7.8 8.2 8.6T, showing the typical training effect.

After considering the difference between Technique C and Techniques A and B, A and B use a filler, either Al_2O_3 plus wax or Gd_2O_3 plus wax, while C does not have a filler. Thus it can be concluded that increasing

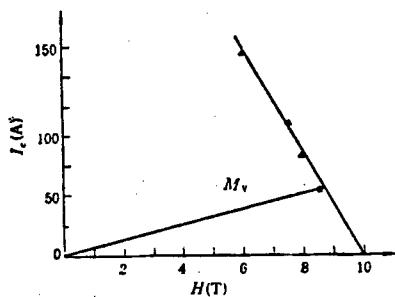

Figure 4. Excitation Characteristics of the Magnet

winding tension alone cannot avoid slippage (or microscopic slippage). Filling the gaps with wax has improved mechanical stability.

(3) The central fields of the six magnets prepared with the three different techniques mentioned above all reached above 8.5T. The maximum B_{00} is approximately equal to 9.24T. This is a record high field in China with a Nb-Ti magnet at 4.2 K. It is approaching the limit on the Nb-Ti line at 4.2 K.

The characteristics of the magnet are: at 4.2 K and 9.0T the critical current density of the Nb-Ti wire itself is $J_{c.s.}$ approximately equal to $4.74 \times 10^4 A \cdot cm^{-2}$. The average current density of the conductor = $1.97 \times 10^4 A \cdot cm^{-2}$ and the average current density of the winding is $J_{(average)c.w}$ approximately equal to $1.46 \times 10^4 A \cdot cm^{-2}$.

(4) Fast Excitation Test

The experiments were done with M_I , M_{II} , M_{III} , and M_{IV} . The power supply used was JWL-150A which can be operated manually or automatically. A copper magnetic resistance probe, which was calibrated in a nuclear magnetic resonance machine, was placed at the center of the magnet. The terminal voltage (the magnetic field) and the voltage across the shunt (the operating current of the magnet) are simultaneously being input into an analog recorder and a multi-channel digital voltmeter in order to obtain the $B(I)$ varies as t curve. The data are compared to the steady rate results in order to ascertain that no leakage current is produced.

The continuous saw-tooth shaped scan curves are shown in Figures 5 and 6.

Tables 2, 3, and 4 show the parameters associated with the superconductors used in the four magnets and the excitation data.

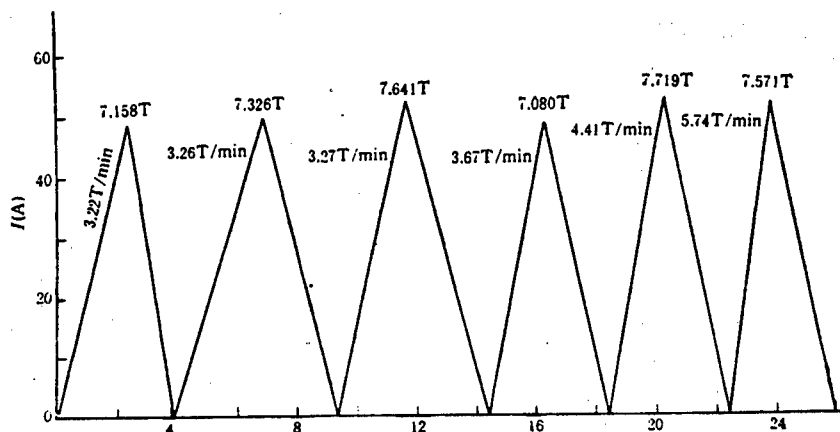

Figure 5. Fast Excitation Curve for M_{VI} (first run)

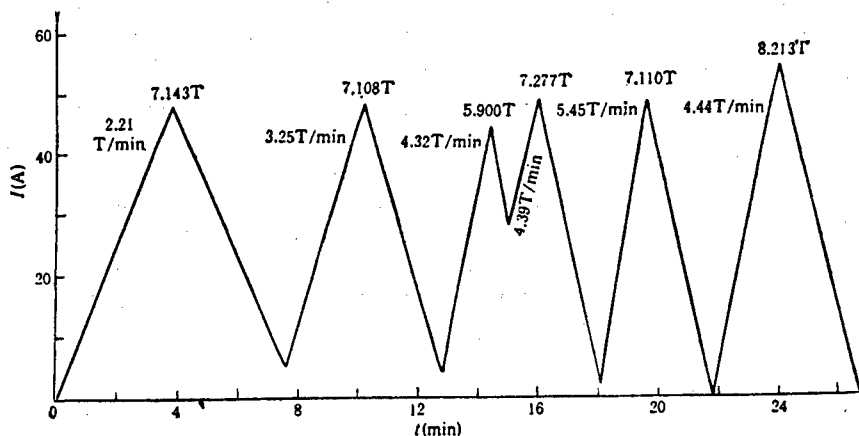

Figure 6. Continuous Fast Excitation Curve for M_{VI} (second run)

Based on Figures 5 and 6 and Tables 3 and 4 we can see that the magnet could be excited to 8T in 2 minutes. At 5.74T/min, it was excited to 7.6T without quenching. (The maximum excitation rate was not measured due to limitation in the voltage of the power supply.) This shows that the binary superconducting wire has a higher stability against magnetic excitation and it may be used to wind pulse magnets such as the one used to measure magnetizing curves.

(5) The results of repeated quenching and heat-cool cycling indicate that these magnets are more stable. For example, M_{IV} could still operate stably at 8.6T after 10 quenches and 8 heat-cool cycles. In combination with Nb_3Sn , in the event of Nb_3Sn quenching, the NbTi system was disturbed by Nb_3Sn 11 out of 12 times. This shows that it has a higher interference resistance. Of course, the long term stability of the magnet has yet to be

tested in actual use. Potential problems associated with the technology may be exposed and rectified.

5. Conclusions

In order to obtain a high field NbTi magnet, we should understand various possible disturbance processes inside a magnet and take appropriate actions to counter the sources of disturbance.

We believe the key of the technique is:

to choose a proper filler (a low elastic modulus filling agent with a high heat capacity or high thermal conductivity material), to apply the appropriate winding tension to completely avoid wire movement, and to use a high strength material (such as stainless steel) to reinforce the magnet in order to prevent deformation and to overcome mechanical instability.

Magnet Number	Superconductor Parameters							
	Wire Diameter (mm)		Copper Ratio		Filament Diameter (μm)		Number of Filaments	
	Inner	Outer	Inner	Outer	Inner	Outer	Inner	Outer
M_I	0.66	0.45	1.4	1.26	25	25	306	159
M_{II}	0.66	0.45	1.4	1.26	25	25	306	159
M_{III}	0.66	0.45	1.4	1.26	25	25	306	159
M_{IV}	0.66	0.45 0.40	1.4	2 1	25	25	306	159

Table 2

Magnet Number	Experiment Number	Current Rise Time (S)	Maximum Current (A)	Field Achieved (T)	Excitation Rate (T/min)	Quench or Not
M_I	1	108	39.5	6.70	3.72	No
	2	110	40.5	6.87	3.75	No
	3	121	44.1	7.48	3.71	No
	4	183	48.3	8.20	2.69	No
	5	120	49.3	8.37	4.19	No
	6		50.8	8.62	2.35	Critical quench
M_{II}	1	130	46.0	7.93	3.66	No
	2	132	51.3	8.84		Critical quench
M_{III}	1	160	44.0	7.58	2.80	No
	2	120	46.0	7.92	3.96	No
	3	80	34.6	5.69	4.20	No
	4	108	46.0	7.93	4.40	No
	5	114	47.0	8.10	4.30	No
	6	180	49.8	8.58	2.90	Critical quench

Table 3. Data Obtained with M_I , M_{II} , M_{III}

To adopt a rational layer structure, to optimize the relative cross-section of the superconductor, to eliminate the unnecessary insulating material, and to improve the filling factor can achieve a higher field strength with less superconducting wire.

The lead must be properly constructed with a protective design to increase the useful lifetime of the magnet.

This work is part of the superconductor project at the institute. Professor Hong Chaosheng [3136 2600 3932] offered his support and beneficial guidance. Organizations such as the Institute of Non-Ferrous Metals provided high quality superconducting wire. Zhang Qirui [1728 0366 3843] of China Science and Technology University has been working closely at the Institute of

Excitation Sequence	Current Rise Time (S)	Maximum Current (A)	Field Achieved (T)	Excitation Rate (T/min)	Remarks
1	190	48.7	7.18	2.26	
2	134	48.7	7.18	3.22	
3	208	52.0	7.67	2.21	
4	140	51.5	7.59	3.24	
5	133	48.5	7.16	3.22	
6	135	49.7	7.33	3.26	
7	140	51.8	7.64	3.27	
8	116	48.0	7.08	3.67	
9	105	52.3	7.72	4.41	
10	79	51.3	7.57	5.74	
1	194	48.4	7.14	2.21	
2	120	48.2	7.11	3.25	initial field 0.71(T)
3	75	40.0	5.90	4.32	0.50
4	44	49.4	7.28	4.39	4.07
5	75	48.2	7.11	5.45	0.30
6	111	55.7	8.21	4.44	0
7	170	61.8	9.11	2.27	critical quench at 2.66

Table 4. Excitation Data Obtained with M_{VI}

Magnet Physics. Beijing Institute of Physics and Shanghai Institute of Metallurgy measured some magnets and provided the data. The authors wish to express their gratitude to the people mentioned above.

References

1. Smith, et al., *Cryogenics* 15, No 4 (1975).
2. Ding Liren [0002 4539 0086], et al., *DIWEN WULI [LOW TEMPERATURE PHYSICS]* 1, No 2 (1979).
3. Han Hanmin [7281 3352 3046], et al., *DIWEN WULI [LOW TEMPERATURE PHYSICS]* 2, No 1 (1980).
4. S. S. Rosenblum, et al., *IEEE Trans on Mag, MAG-13* No 1.
5. Wilson, et al., *IEEE Trans on Mag, MAG-17*.
6. Jiao Zhengkuan et al., "Study on Thermal Pulse Resistance and Propagation in Quenching Area of Nb-Ti Magnets Wound by Different Techniques," *DIWEN WULI [LOW TEMPERATURE PHYSICS]* (to be published).

12553/09599

Prototype Test of Control Rod Drive Mechanism Used in Qinshan Nuclear Power Plant

40090047a Chengdu HE DONGLI GONGCHENG [NUCLEAR POWER ENGINEERING] in Chinese Vol 8 No 6, Dec 87 pp 18-20, 36

[English abstract of article by Gao Jiyun [7559 7139 6663], et al.]

[Text] This paper briefly presents the functions, design data, structure and design features of the control rod drive mechanism (CRDM). The purpose and test results of the performance test are described, too. Test results show that the performance of the CRDM is nearly the same as that of similar ones used abroad. The prototype mechanism passed the 2.7×10^6 step hot test, and could still be operated continuously.

9717/9604

Protective Coating for Facilities in PWR Containment

40090047b Chengdu HE DONGLI GONGCHENG [NUCLEAR POWER ENGINEERING] in Chinese Vol 8 No 6, Dec 87 pp 21-25, 48

[English abstract of article by Wang Yuehua [3769 2588 5478]]

[Text] The issue involving screening certain coating systems, which will be applied to PWR containment facilities, is of great significance.

This paper describes the process for determining the coating systems for the Qinshan Nuclear Power Plant containment ambient temperature facilities (not including the lining surfaces of tank vessels and similar facilities used to contain chemicals or chemical solutions). The coating systems are determined by screening tests, such as radiation exposure, decontamination, testing of LOCA (loss of coolant accident), chemical test procedure, physical test procedure, etc.

9717/9604

Burnup Determination of Mass Spectrometry for Nuclear Fuels

40090047c Chengdu HE DONGLI GONGCHENG [NUCLEAR POWER ENGINEERING] in Chinese Vol 8 No 6, Dec 87 pp 49-56

[English abstract of article by Zhang Chunhua [1728 2504 5478]]

[Text] The various methods currently being used in burnup determination of nuclear fuels are studied and reviewed. The mass spectrometry method of destructive testing is emphasized. The burnup determination of mass spectrometry includes the heavy isotopic abundance ratio method and the isotope dilution mass spectrometry used for the fission product as the burnup indicator. The former is applied to a high burnup level, but the latter is applied to various burnup levels. Finally, the author presents a few problems noted while using mass spectrometry for burnup determination.

9717/9604

Effects of Nuclear Irradiation on Calibration of New Nickel-Based Alloy Thermocouple

40090047d Chengdu HE DONGLI GONGCHENG [NUCLEAR POWER ENGINEERING] in Chinese Vol 8 No 6, Dec 87 pp 67-70, 90

[English abstract of article by Wei Huixiang [7279 2585 4382], et al.]

[Text] This paper describes the effects of nuclear irradiation on the calibration of a new nickel-based alloy thermocouple in the High Flux Engineering Test Reactor (HFETR). The melting point of lead (327.5°C) was used as a standard reference temperature for the calibration of the thermocouples. A special irradiation facility for the calibration, which was inside a capsule, was placed in the center of the reactor. Both the gamma heating of the materials and the adjustment of the ratio of helium-nitrogen in the capsule controlled the test temperature. A comparison with the thermocouple's properties under irradiation was provided by simultaneously testing a conventional nickel-based alloy thermocouple which had already been used in in-reactor temperature measurement.

The experimental results indicate that the transient effect of irradiation on insulation-type thermocouples is the main source of error for temperature measurement in the HFETR.

9717/9604

Quasi-CW Actively Mode-Locked, Q-Switched Nd:YLF Oscillator

40090046a Shanghai GUANGXUE XUEBAO [ACTA OPTICA SINICA] in Chinese
Vol 7 No 11, Nov 87 pp 961-968

[English abstract of article by Cao Weilou [2580 3262 2869], et al., of Shanghai Institute of Optics and Fine Mechanics, Chinese Academy of Sciences; Zhu Zhimin [2612 2535 2404], et al., of the Department of Physics, Fudan University, Shanghai]

[Text] A quasi-CW actively mode-locked and Q-switched (AMQ) Nd:YLF oscillator for a phosphate Nd:glass laser fusion system has been developed successfully. This paper describes the stability, reliability and high contrast of signal to noise of the AMQ laser pulses.

9717/9604

Three-Plate Optical Resonant Reflectors and Their Design

40090046b Shanghai GUANGXUE XUEBAO [ACTA OPTICA SINICA] in Chinese
Vol 7 No 11, Nov 87 pp 976-982

[English abstract of article by He Weiming [0149 0251 2494], et al., of Shanghai Institute of Optics and Fine Mechanics, Chinese Academy of Sciences]

[Text] This paper describes characteristics of frequency and space reflection spectra of multiplate resonant reflectors. The authors mainly analyze the effects of thicknesses of glass and air gaps on the reflection spectra and the space reflection spectra due to each optical plane not being parallel in the degenerate resonant reflectors. The requirements for designing the resonant reflectors are provided and some methods for solving the problems are shown. Non-degenerate resonant reflectors are also discussed.

9717/9604

Q-Modulation, Four-Wave Mixing Effects Caused by RSA Materials in Laser Cavity

40090046c Shanghai GUANGXUE XUEBAO [ACTA OPTICA SINICA] in Chinese
Vol 7 No 11, Nov 87 pp 983-989

[English abstract of article by Zhang Tao [1728 3447], et al., of the Department of Precision Instrument Engineering, Tianjin University]

[Text] By making use of the density matrix method, the authors present a unified explanation of Q-modulation and four-wave mixing effects caused by resonant saturable absorption (RSA) materials in a laser cavity. The

underlying physical mechanism of the effects is expressed clearly. The theoretical calculation results agree with the experimental data very well.

9717/9604

Stimulated Raman Scattering in Hydrogen, Methane Mixture

40090046d Shanghai GUANGXUE XUEBAO [ACTA OPTICA SINICA] in Chinese
Vol 7 No 11, Nov 87 pp 990-994

[English abstract of article by Zhao Zhensheng [6392 7201 5116], et al., of Anhui Institute of Optics and Fine Mechanics, Chinese Academy of Sciences]

[Text] The stimulated Raman scattering effect in hydrogen and methane mixtures is investigated using the frequency-doubled output (532 nm) of a Nd³⁺:YAG laser as the pumping source. For different ratios of the mixture, both the SRS lines and combinations (equivalent of $V_1 =$ equivalent of $V_p + gDm$ equivalent of $V_1(H_2) + ngD$ equivalent of $V_2(CH_4)$, $m, n=0$, plus or minus 1, plus or minus 2, ...) of H₂ and CH₄ are observed by an optical spectrum analyzer (OSA WP-4), and shifts in the SRS lines are found. Suppression and coupling between the hydrogen and methane in the mixture are shown. A preliminary explanation of the experimental results is discussed in the paper.

9717/9604

Study of Dynamic Processes for Colliding Pulse Mode-Locking Dye Lasers

40090049a Shanghai GUANGXUE XUEBAO [ACTA OPTICA SINICA] in Chinese
Vol 7 No 12, Dec 87 pp 1057-1062

[English abstract of article by Wang Qingyue [3769 3237 2588], et al., of the Department of Precision Instrument Engineering, Tianjin University]

[Text] According to the rate equation, a theoretical model describing the dynamic processes for colliding pulse mode-locking (CPM) dye lasers is established in this paper. In this theoretical model, saturations of the gain and absorbing media, interaction between the pulses and the population distribution grating introduced by the two pulses colliding in the absorber jet, and dispersion are included. Using this theoretical model, the authors calculated the dynamic processes for CPM dye lasers. In particular, the evolution of the pulse duration with around trip number is calculated numerically. The authors found that the difference between durations of the two pulses propagating clockwise and counter-clockwise in the cavity was strongly dependent on the relative position of the gain jet and the absorber jet in the cavity. The dependence of the pulse duration

and pulse shape on the pump rate, cavity length, loss and cavity structure is calculated numerically. The asymmetry of the pulse shape is obtained for certain cavity structures.

9717/12232

Contribution Limitation of Side-Band Sum-Frequency Processes to Laser Frequency Conversion

40090049b Shanghai GUANGXUE XUEBAO [ACTA OPTICA SINICA] in Chinese
Vol 7 No 12, Dec 87 pp 1063-1068

[English abstract of article by Qiu Zhiren [8002 1807 0088], et al., of Shanghai Institute of Optics and Fine Mechanics, Chinese Academy of Sciences]

[Text] According to the equations of three interacting plane waves (without absorptions and losses) and small-signal approximation, the calculations of spectral and angular acceptance half-widths are made with KDP, ADP BBO, LiIO_3 , and LiNbO_3 for frequency doubling, tripling and quadrupling ($g_1 = 1.064 \text{ gm m}$) so that crystals can be selected for use in frequency-conversion in a wide-band Nd:glass laser. The doubling equations for wide-band mode-locked lasers are given. The enhancement factor $(2N^3+N)/3$ of SH shows that side-band sum-frequency processes for mode-locked laser pulses have important roles.

9717/12232

Rotating Aperture Method of Speckle Photography for Dynamic Problems. I: Two-Aperture, Four-Fan-Aperture

40090049c Shanghai GUANGXUE XUEBAO [ACTA OPTICA SINICA] in Chinese
Vol 7 No 12, Dec 87 pp 1069-1075

[English abstract of article by Gu Jie [7357 2638], et al., of the Department of Physics, Suzhou University]

[Text] In this paper, a new experimental technique—rotating aperture method of speckle photography for dynamic problems—is proposed. The displacement field of any moment of a specimen can be obtained, while only simple equipment is needed. Using a rotation device, the whole dynamic process can be recorded on a single specklegram, and then information of every moment can be separated easily by whole-field filtering. This method is applicable not only to vibration problems, but also to non-periodic dynamic problems. Three experiments have been conducted for demonstration purposes. Speckle fringes are clear and reliable. The quantitative analysis of the experiments have been conducted for demonstration purposes. Speckle fringes are clear and reliable. The quantitative analysis of the experiments agrees well with the results obtained from other methods.

9717/12232

Magneto-Optical Bistability

40090049d Shanghai GUANGXUE XUEBAO [ACTA OPTICA SINICA] in Chinese
Vol 7 No 12, Dec 87 pp 1076-1081

[English abstract of article by Dong Xiaoyi [5516 1321 5030], et al., of the Institute of modern Optics, Nankai University, Tianjin]

[Text] In this paper, a magneto-optical bistable device with a specially-designed magneto-optical modulator made of a new type of magnetic glass is presented. With this device, the optical bistable experiment has been performed, and the bistable characteristics and relevant parameters have been measured. The results are in good agreement with the theoretical analyses.

9717/12232

Dynamics Analyses of NH_3 Multiphoton Ionization, Fragmentation

40090049e Shanghai GUANGXUE XUEBAO [ACTA OPTICA SINICA] in Chinese
Vol 7 No 12, Dec 87 pp 1082-1087

[English abstract of article by Li Shutao [2621 2579 3447], et al., of Anhui Institute of Optics and Fine Mechanics, Chinese Academy of Sciences, Hefei]

[Text] This paper analyzes the formation mechanism in NH_3 multiphoton ionization mass spectra induced by a XeCl excimer laser. The establishment model shows that $\text{NH}^+_{3/3}$ is mainly yielded in (2+1) multiphoton ionization via the Rydberg states B(6) and C'(1), and $\text{NH}^+_{1/4}$ formed from an ion-molecule reaction, $\text{NH}^+_{3/3}(\text{NH}_3, \text{NH}_2)\text{NH}^+_{1/4}$ and very low-yield $\text{NH}^+_{1/2}$ are most probably produced from (2+2) multiphoton ionization via the resonant intermediate state B(6). The rate equation solution for this model is in good agreement with the authors' experimental results. It predicts that the information on direct or indirect ionization mechanism are involved in the dependencies of ion intensity on laser pulse duration.

9717/12232

Method of Inspection of Optical Synthetic Aperture Radar Processor

40090049f Shanghai GUANGXUE XUEBAO [ACTA OPTICA SINICA] in Chinese
Vol 7 No 12, Dec 87 pp 1099-1105

[English abstract of article by Jin You [6855 0645] of Changchun Institute of Optics and Fine Mechanics, Chinese Academy of Sciences]

[Text] In this paper, a general OSARP (Optical Synthetic Aperture Radar Processor) inspection is presented as an example to explain the method of inspection of an OSARP. The author relates the adjustable quantities of

each adjustable assembly of the OSARP with each characteristic number of SAR (Synthetic Aperture Radar) data film. The applicable range of the OSARP is obtained by testing the adjustable quantities. The imaging quality of the OSARP is inspected using general testing targets and a shift lens. The advanced inspection of the OSARP is conducted with the simulated SAR data films. It is a different method, but the results are the same as formerly obtained. Finally, the SAR data film is processed to show the comprehensive imaging quality of the SAR and the OSARP. The experimental pictures and data presented in this paper are for reference only. The experimental results show that the method is applicable.

9717/12232

Light Propagation in Active Fibers

40090049g Shanghai GUANGXUE XUEBAO [ACTA OPTICA SINICA] in Chinese
Vol 7 No 12, Dec 87 pp 1106-1111

[English abstract of article by Wen Tingdun [3306 1694 2415], et al., of the Department of Physics, Shanxi University, Taiyuan]

[Text] In this paper, the authors deduce the equations of motion for both cw and long-pulse light in active fibers. They then solve the equations under zero-order and first-order perturbations using the quantum theory involving the polarization of an active material. A quantitative description is then given of the evolutions of amplitudes and phases of the cw and long-pulse light, and the influence of the active material on the group velocity of the long pulse light is discussed.

9717/12232

Error Analysis for Ring-Laser Weak Magnetic Field Sensor

40090049h Shanghai GUANGXUE XUEBAO [ACTA OPTICA SINICA] in Chinese
Vol 7 No 12, Dec 87 pp 1112-1117

[English abstract of article by Zhang Shulian [1728 2579 4886], et al., of the Department of Precision Instruments, Qinghua University, Beijing]

[Text] the main errors involving a ring-laser weak magnitude magnetic field sensor are analyzed, and the methods to eliminate these errors are discussed. The error introduced by temperature coefficient of the Verdet constant of magneto-optical materials is derived theoretically. This is the main source of error due to the temperature coefficient of a ring-laser weak magnetic field sensor after low expansion cavity materials and the frequency stabilization technique have been used. The error introduced by the Zeeman effect is given. The Zeeman effect error results from the magnetic field sensitivity of the gain medium, and it is mixed with the magnetic field sensitivity of the Faraday magneto-optical material. By locating a gain tube in each longer arm

of the rectangular cavity, the Zeeman effect can be avoided. the two gain tubes have the same parameters (such as core length, diameter, total and partial pressure, discharge current and dimensions of cathode). The influence of the Langmuir gas flow effect can be eliminated by beating positive and negative rotations and then adding the beats of the right and left rotations.

9717/12232

Breakdown Condition in Tokamak

40090052a Beijing WULI XUEBAO [ACTA PHYSICA SINICA] in Chinese
Vol 36 No 11, Nov 87 pp 1385-1394

[English abstract of article by Yang Shicai [2799 1102 2088], et al., of the Institute of Physics, Chinese Academy of Sciences]

[Text] An experiment has been conducted on the CT-6B tokamak in order to study the effect of discharge conditions, such as filling gas pressure, toroidal field, stray magnetic fields and loop voltage, on the breakdown. It is found at the dependence of the breakdown voltage on the vertical stray field is obviously different from that on the horizontal stray field. The main experimental results show discrepancies from those of the Townsend discharge model. The distribution function of electrons during the breakdown phase has been solved using a Monte-Carlo code, and the breakdown condition deduced from the Townsend model has been revised.

9717/12232

Bulk, Interface Defects in Electron Irradiated InP

40090052b Beijing WULI XUEBAO [ACTA PHYSICA SINICA] in Chinese
Vol 36 No 11, Nov 87 pp 1408-1415

[English abstract of article by Peng Cheng [1756 2110], et al., of the Institute of Modern Physics, Fudan University, Shanghai]

[Text] Systematic studies of the structure of defects in InP caused by electron irradiation are conducted based on the experimental measurements and theoretical calculations. The introduction rates and annealing out temperatures of In and P vacancies are estimated using proper theoretical models. These calculations reveal that after room temperature irradiation only complexes may exist. Also supported by the authors' experimental data is the fact that the sum of the introduction rates of three detected levels is less than the theoretical value calculated for single vacancies.

According to the authors' equation of the relationship between interface states and the DLTS signal and the result of computer calculations, it is believed that the broad peak appearing in the DLTS diagram before irradiation is related to the interface states. Its disappearance after electron irradiation suggests a reduction

in the interface state. This is further confirmed by the reduction of the surface recombination rate derived from the results of surface photo voltage measurements.

9717/12232

Infrared Absorption of Doped Silicon Passivated by Atomic Hydrogen, Deuterium, Implanted by Proton

40090052c Beijing WULI XUEBAO [ACTA PHYSICA SINICA] in Chinese
Vol 36 No 11, Nov 87 pp 1427-1432

[English abstract of article by Du Yongchang [2629 3057 2490], et al., at the Department of Physics, Beijing University; Hu Keliang [5170 0344 5328] of the Center of structure Analysis, University of Science and Technology of China, Hefei]

[Text] FTIR was employed to study doped silicon passivated by atomic hydrogen, deuterium and implanted by protons. The localized vibrational modes of [BD] pairs, 1360 cm^{-1} and 1263 cm^{-1} , were excited with different passivation conditions of atomic deuterium. This shows that there are at least two possible positions for deuterium atoms around acceptor B. The IR absorption spectra of doped silicon implanted by protons are different from those of undoped silicon, with the hydrogen atoms preferring bonding around the B acceptors. Only 1 percent of the implanted hydrogen atoms were turned into photoactive centers. Most of the implanted hydrogen atoms formed non-photo-active centers and might be hydrogen molecules, Hz.

9717/12232

A New Threshold Voltage Model for the Nonuniform Doping Small Size MOSFETs for VLSI CAD

40090055a Beijing BANDAOTI XUEBAO [CHINESE JOURNAL OF SEMICONDUCTORS] in English
Vol 8, No 6, Nov 87 p 596

[Article by Wang Jianwei and Ruan Gang (Institute of Microelectronics, Fudan University)]

[Abstract] The limitations of the availability model for MOSFETs threshold voltage are discussed. Based on the formula derived by piecewise approximation, a new V_T model is presented, which can reflect the threshold voltage body effect of nonuniform doping MOSFETs. It is suitable not only for shallow implantation but also for deep implantation and not only for long channel devices but also for small size devices. It is shown that the calculated results of the new model formula are quite consistent with that of numerical simulator MINIMOS. Particularly, the new model formula is suitable for VLSI CAD.

/9604

Characterization and Modeling of LDD [Lightly Doped Drain] MOSFETs

40090055b Beijing BANDAOTI XUEBAO [CHINESE JOURNAL OF SEMICONDUCTORS] in English
Vol 8, No 6, Nov 87 p 603

[Article by Xie Liansheng, Chen Xueliang and Xu Yuansen (Shanghai Institute of Metallurgy, Academia Sinica)]

[Abstract] One gmm channel length LDD MOSFET was fabricated with a novel processing technique proposed in this paper and characterized by means of the analysis of hot electron injection current, breakdown voltage and series resistance. The results show that the substrate current of the LDD devices is reduced by 2 orders of magnitude, and the source/drain breakdown voltage is increased by 5 volts as the channel length equals 1 gmm. In addition, an analytical model which includes hot electron effects is developed for the formulation of LDD MOSFETs. The calculated results are in good agreement with the measured data.

/9604

Measurements of Reflectivity for Perfect or Nearly-Perfect Crystals Using Dispersive Double-Crystal Diffractometry

40090055c Beijing BANDAOTI XUEBAO [CHINESE JOURNAL OF SEMICONDUCTORS] in English
Vol 8, No 6, Nov 87 p 642

[Article by Chen Jingyi, Li Runsheng and Xu Shunsheng (Shanghai Institute of Metallurgy, Academia Sinica)]

[Abstract] The double-crystal rocking curves of various settings are analysed by DuMond graphic method. The new method to determine the reflectivity for perfect or nearly-perfect crystals using dispersive double-crystal diffractometry is provided and verified by experiment and computer simulation.

/9604

A New Explanation for the Dependence of the Pinning Position of Fermi Level on the Composition of GaAs (100) Surface

40090055d Beijing BANDAOTI XUEBAO [CHINESE JOURNAL OF SEMICONDUCTORS] in English
Vol 8, No 6, Nov 87 p 649

[Article by Zhang Xiangjiu (Laboratory of Surface Physics, Fudan University)]

[Abstract] Barrier heights of Schottky diodes made by Sb and GaAs (100) strongly depend on the surface composition of GaAs. It means that the pinning position of the Fermi level of GaAs has been shifted. These experimental results can hardly be explained directly by the present theory concerning the contacts of semiconductors with metals. In this article the concept of the neutral level of

the surface in Bardeen's theory will be developed, and then a new explanation for the dependence of the barrier heights of Sb-(100) GaAs Schottky diodes on the surface composition will be given.

/9604

Relationship Between Quasi-cylindrical Approximation, Critical Classification for Swirling Flow

40060054a Beijing LIXUE XUEBAO [ACTA MECHANICA SINICA] in Chinese
Vol 19 No 6, Nov 87 pp 491-499

[English abstract of article by Shi Xungang [2508 8113 0474], et al., of the Department of Mechanics, Beijing University. Projects supported by the Science Fund of the Chinese Academy of Sciences]

[Text] It is shown analytically that solutions of the quasi-cylindrical approximation are qualitatively governed by the critical classification, with the critical state corresponding to singularity. As flows approach the critical state from both sides, the radial components of velocity separate to positive and negative infinity. In addition, for inviscid quasi-cylindrical flow, only the trivial solution, i.e., strictly columnar flow, is possible. It is also shown that, in the subcritical range, the iterative procedure accounting for nonlinear effects necessarily diverges.

9717/08309

Theoretical Prediction of Cavitation Inception—Fuzzy Cavitation System

40090054b Beijing LIXUE XUEBAO [ACTA MECHANICA SINICA] in Chinese
Vol 19 No 6, Nov 87 pp 508-515

[English abstract of article by Xue Weixin [6079 5898 2450] of East China Technical University of Water Resources; Pan Sensen [3382 2773 2773], et al., of the China Ship Science Research Center]

[Text] In this paper, a fuzzy cavitation system is established. The flow around the rigid body is regarded as a whole system in which the authors observe whether cavitation occurs under given conditions. An analytical method for predicting cavitation inception and its type is presented using fuzzy mathematics theory, which is also applied to deal with the information about the cavitation system and to construct the fuzzy state transform matrix for roughly determining the cavitation state on the body.

9717/08309

Reflective Photoelasticity, Holoferometry Applied to Stress Wave Propagation

40090054c Beijing LIXUE XUEBAO [ACTA MECHANICA SINICA] in Chinese
Vol 19 No 6, Nov 87 pp 529-535

[English abstract of article by Tong Jingwei [0157 2529 0251], et al., of Tianjin University]

[Text] The principal stress distribution on a section of a polyester model of a semi-infinite plate during the propagation of a stress wave has been determined experimentally. The stress pulse was generated by the impact of a pendulum hammer. Two external suitable trigger mechanisms were used to trigger a double-pulse ruby laser (0.5 Joule per pulse) at predetermined intervals. One surface of the model was made fully reflecting so that, by means of reflective holoferometry of that surface and reflective photoelasticity through the other surface of the model, the isopachic and isochromatic fringe patterns could be recorded at different time delays following impact.

9717/08309

Study of New Superconductor Ba-Y-Cu Oxides With High Critical Temperature T_c by Positron Annihilation

40080040 Shanghai HE JISHU [NUCLEAR TECHNIQUES] in Chinese
Vol 10, No 12, Dec 87 pp 1-3

[Article by Zhang Guocai [1728 0948 2088], Yu Xuxing [0151 4371 5281], Wang Zhu [3769 2691], Huang Zhe [7806 0772] and Zhou Jun [0719 7486] of Wuhan University: "Study of New High Critical Temperature T_c of Ba-Y-Cu Oxide Superconductors by Positron Annihilation"]

[Text] Abstract: This paper introduces positron annihilation to study the new superconducting Ba-Y-Cu oxides with high critical temperature T_c . It was found experimentally that the decrease in positron lifetime agrees with the resistance versus temperature curve below the transition temperature. At the critical temperature, T_c , the positron lifetime peaks out.

Key Words: Positron, Annihilation, Positron Life Spectrum, Superconductor, Ba-Y-Cu Oxides, Doppler Broadening

1. Introduction

Recently, there have been breakthroughs in superconductor research in the world. New superconductors with critical temperature T_c above the liquid nitrogen temperature have been successfully developed [1,2]. People are investigating the mechanism and analyzing the structure of these new high T_c superconducting materials. Wide ranging studies are being conducted on the La-Ba-Cu-O series of superconductors [3-6]. Experimental

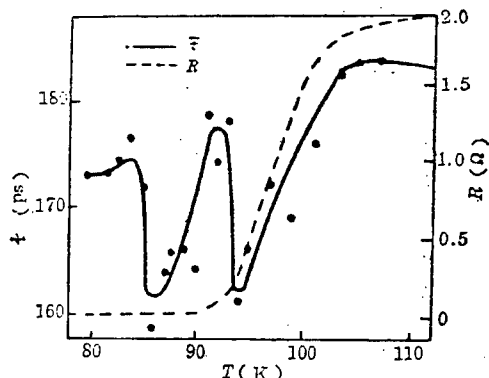

Figure 1: Mean Positron Lifetime and Resistance vs. Temperature

studies on the Ba-Y-Cu-O series are also being carried out with X-ray and electron diffraction techniques [7]. In this paper, positron lifetime measurement and Doppler broadening techniques are used to detect microscopic information of the high T_c superconducting Ba-Y-Cu oxides. The focus is placed in the most intriguing transition temperature region.

2. Specimens and Experimentation

The high T_c superconductors belong to the Ba-Y-Cu oxide series. Specimens were sintered by using spectral pure grade oxides of Ba, Y and Cu at high temperature. The resistance versus temperature data was obtained using the standard four wire method. The specimen used in positron annihilation has a critical temperature $T_c = 92$ K. The initial transition temperature is $T_i = 102$ K. The resistance versus temperature curve of the specimen is shown in Figure 1.

The positron spectrometer consists of two ORTEC 583 differential constant ratio discriminators and two fast coincidence systems with BaF_2 probes. The time resolution is better than 230 ps. The low temperature system and its control unit are made by OXFORD instruments. The lifetime spectrum measured was fitted by the least square method with respect to the three components. The positron annihilation Doppler broadening technique uses a CANBERRA high purity germanium detector. Its energy resolution is 1.9 keV with respect to the 1.17 MeV γ -ray of ^{60}Co .

3. Results and Discussion

The lifetime spectrum was computer fitted to obtain its three components τ_1 , τ_2 , and τ_3 and the corresponding intensities I_1 , I_2 , and I_3 . The mean lifetime of a positron $\bar{\tau}$ is defined as

$$\bar{\tau} = \frac{\sum_{i=1}^3 I_i \tau_i}{\sum_{i=1}^3 I_i}$$

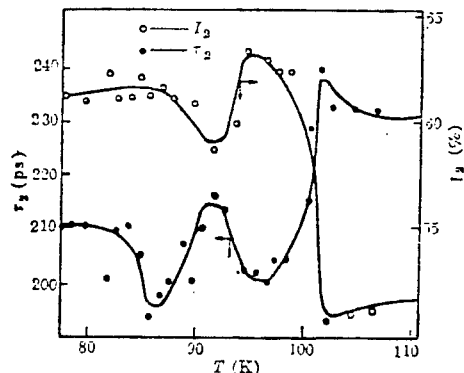

Figure 2. Temperature Dependence of the Second Lifetime Component and Intensity

It varies with temperature as shown in Figure 1. In order to analyze the microscopic structure changes of the superconductor in the transition region, the temperature axis in Figure 1 is expanded. We can see that τ mean value drops rapidly below the initial temperature. It fell from 183ps at 103 K to 161 ps at 94K. Around the critical temperature of 92 K, the mean positron lifetime τ mean value showed a small peak at 175ps.

Figure 2 shows the relation between the capture life τ_2 and relative intensity I_2 . The τ_2 versus temperature curve shows an opposite trend to the I_2 versus temperature curve. The dependence of τ_2 upon temperature is identical to the dependence of τ mean value upon temperature shown in Figure 1. At below 102 K, τ_2 decreases with temperature. At 92 K, τ_2 also has a peak just as in the case of τ mean value. It is approximately 215 ps which is more than 10 ps higher than the values in the neighboring valleys.

Let us consider that I_3 is less than 4 percent and the third lifetime component τ_3 can be neglected and is due to the surface effect of the specimen. Let us take the weighted average of τ_1 and τ_2 and call it $\tau_{mean} = (I_1 \tau_1 + I_2 \tau_2) / (I_1 + I_2)$. Its temperature dependence is shown in Figure 3. It is consistent with the curves for τ mean value and τ_2 . We also made Doppler broadening measurements with that sample. Similarly, we found that the linear parameter S has a peak near the critical temperature T_c . This result will be published separately. All the above results are in good agreement, which is very significant.

Below the initial transition temperature, τ_{mean} value, τ_2 and τ_{mean} decrease with lowering temperature, in good agreement with the resistance versus temperature curve. J.D. Jorgenson et al conducted a neutron diffraction study on the high T_c superconductor $La_{2-x}Ba_xCuO$ and found no phase transition in a wide temperature range from 295 K to 10 K [6]. Some of the authors participated in an X-ray diffraction study of Ba-Y-Cu oxides and found no apparent lattice transformation from ambient temperature to 82 K. Xie Sishen et al observed structural

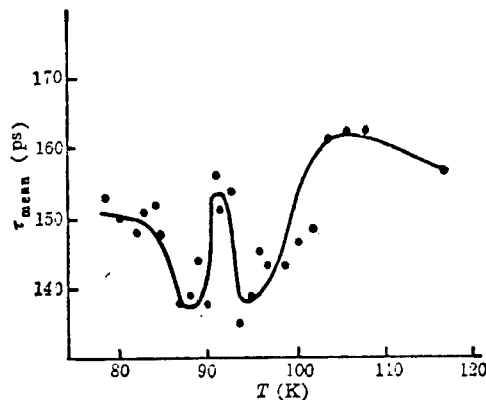

Figure 3. Weighted Mean Lifetime vs. Temperature

inhomogeneity in their study of the high T_c Ba-Y-Cu-O [7]. Since positron lifetime is extremely sensitive to microscopic defect and phase transformation, we believe that the positron lifetime in the superconducting Ba-Y-Cu oxide is primarily related to the microscopically defective phase. The variation of positron lifetime with temperature reflects the variation of the microscopic defects in the superconductor with temperature. The higher the positron lifetime is, the more inhomogeneous the microscopic structure becomes. At below the initial transition temperature, the positron lifetime declines, indicating a decrease in the microscopic defect. The structure becomes more uniform. It is interesting for the positron lifetime to show a peak at the critical temperature. To explain this effect, let us assume that each homogeneous region in the superconductor is a domain. The changes across the domains and the boundaries are defects created by serious inhomogeneity. Thus, very intense positron capture locations are formed. Starting at about 102 K, the changes across domains become less as the temperature drops, leading to smaller τ_2 , τ mean value, and τ_{mean} . When temperature drops further, the wall of the domain will move, creating new electron inhomogeneity. This causes τ_2 , τ and τ_{mean} to rise again, resulting in a peak near the critical temperature. This hypothesis still remains to be verified.

4. Conclusions

This paper used the positron annihilation technique to study the new high T_c Ba-Y-Cu oxide superconducting materials. It was experimentally discovered that the decrease in positron lifetime agrees well with the resistance versus temperature curve below the initial transition temperature. At the critical temperature T_c , the positron lifetime shows a peak. This information is valuable in the analysis of the transition mechanism of the new Ba-Y-Cu oxide superconductors.

References

[1] Zhao Zhongxian [6392 1813 6343] et al, KEXUE TONGBAO [SCIENCE COMMUNICATIONS], 32, 6, 412 (1987).

[2] Huo Changgeng [7202 7022 1649], WULI [PHYSICS], 16, 4, 193 (1987).

[3] J.G. Bendnorz and K.A. Muller, Z. Phys. B Condensed Matter, 64, 189 (1986).

[4] C.W. Chu et al, Phys. Rev. Lett., 58, 408 (1987).

[5] Zhao Zhongxian et al, KEXUE TONGBAO [SCIENCE COMMUNICATIONS], 32, 3, 177 (1987).

[6] J.D. Jorgensen et al, Phys. Rev. Lett., 58, 1024 (1987).

[7] Xie Sishen et al, A high T_c superconducting phase in Ba-Y-Cu-O system, Preprint.

12553/08309

Software System for AAA Fire Control Operational

40080060a Beijing ZHONGGUO DIANZI BAO in Chinese 1 Dec 87 p 1

[Summary] A microcomputer-controlled dynamic analysis software system for high-speed precise direction of anti-aircraft artillery fire, after its appearance early this year in Xinjiang, underwent a half year of testing with excellent results, and was put into operation by the entire army's artillery forces at the beginning of October.

Those responsible for the breakthrough—Assistant Engineers Sun Bo [1327 3134], Cen Shaoming [1478 1421 2494], and Li Guodong [2621 0948 2767] of the Xinjiang Military District Radar Maintenance Unit—spent over 2 years beginning in 1984 in developing this software program for dynamic automatic adjustment of anti-aircraft artillery. Information from maintenance specialists and the laws of artillery correction are woven into the program and inputted into the computer, which then carries out automatic adjustment to correct for the observed error.

The man-machine-interaction operational form is easy and convenient to learn, and is seven times as effective as the outmoded traditional method based on human analysis and computation. According to the evaluation of the specialists assembled by the General Logistics Department, this software system is completely functional, has high adjustment accuracy, speed, and flexibility, and constitutes a major reform in domestic and foreign anti-aircraft technique. It has reached advanced international standards and closes the domestic gap in this field.

07310

JL-7 Radar Passes Reliability Testing
40080060b Beijing ZHONGGUO DIANZI BAO in
Chinese 11 Dec 87 p 3

[Text] Institute No 607 of the Ministry of Aviation Industry has successfully completed reliability testing of the JL-7 airborne fire-control radar. The objective of this testing was to utilize artificially augmented environmental stress methods, under laboratory conditions, to determine the reliability of the radar and to check the quality of selected components and the soundness of the manufacturing technology used in production.

During the comprehensive testing, the radar endured quite rigorous trials. In a 24-hour period, the radar underwent an electronic test while being exposed to various harsh all-season ground and high-atmosphere conditions. In a 90.5-hour period of operation, the radar had to endure a total of 10 full-cycle rapid changes of the [surrounding] temperature from high (80°C) to low (-55°C). In addition, the system was subjected to vibration tests while continuously scanning in the 10-2000 Hz frequency range.

This test was a prerequisite for covering the monopulse radar's most important problems. Altogether, there were eight major items in the testing, resulting in a more complete examination of the radar's performance. It was a convincing demonstration that the JL-7 radar's quality is of a high order, and that its performance is stable and reliable.

07310

Non-Circular Cross Section Tokamak FY-1 Experiment. I. Passive-Control Operation
40090053a Chongqing HEJUBIAN YU DENGLIZITI
WULI [NUCLEAR FUSION AND PLASMA
PHYSICS] in Chinese Vol 7 No 4, Dec 87 pp 193-201

[English abstract of article by Yao Lianghua [1201 5328 7520], et al., of Southwestern Institute of Physics, Leshan, Sichuan]

[Text] The structure and basic parameters of the FY-1 device and experiments on plasma configuration are briefly described. The results show that the present toroidal plasma formed in FY-1 belongs to runaway discharge. The dependence of hard X-ray intensity on the working gas pressure has been investigated preliminarily. The plasma equilibrium and configuration can be adjusted properly by changing the discharge circuit of the field shaping coils and using additional inductors passively controlling the field shaping coil image currents. Variable elongations ($K = 1.1-1.4$) of the elliptic plasma cross section and its areas are determined by fitting the measured magnetic properties based on a free boundary MHD equilibrium theory.

09717/06662

Ion Temperature Measurements in HL-1 Tokamak by Charge-Exchange Method
40090053b Chongqing HEJUBIAN YU DENGLIZITI
WULI [NUCLEAR FUSION AND PLASMA
PHYSICS] in Chinese Vol 7 No 4, Dec 87 pp 222-228

[English abstract of article by Gan Dechange [3927 1795 2490], et al., of Southern Western Institute of Physics, Leshan, Sichuan]

[Text] The ion temperature measurement on the HL-1 tokamak using a six-channel neutral particle analyzer is described. During a discharge, temperatures are measured every 30-50 ms. A typical value of the ion temperature in the plasma core is 474 eV. In comparison, with Artsimovich empirical scaling law gives 450 eV.

09717/06662

Measurement of Electron Density on HL-1 Tokamak Using HCN Laser Interferometer
40090053c Chongqing HEJUBIAN YU DENGLIZITI
WULI [NUCLEAR FUSION AND PLASMA
PHYSICS] in Chinese
Vol 7 No 4, Dec 87 pp 229-233, 221

[English abstract of article by Deng Zhongchao [6772 0022 2600], et al., of Southwestern Institute of Physics, Leshan, Sichuan]

[Text] A Michelson-type FIR interferometer for average electron density $-n_e(t)$ measurement on the HL-1 tokamak is described. The real-time data acquisition and processing was performed by an Apple-II microcomputer.

The variations in electron density have been observed both during gas puffing and during the development of disruptive instability. The measured electron densities are in the range of $(1-3) \times 10^{13} \text{ cm}^{-3}$, with an error of approximately (4-10) percent.

09717/06662

Ion Implantation Equipment LZ-50, Its Application To Modification of Material Surface Properties
40090053d Chongqing HEJUBIAN YU DENGLIZITI
WULI [NUCLEAR FUSION AND PLASMA
PHYSICS] in Chinese
Vol 7 No 4, Dec 87 pp 243-246, 256

[English abstract of article by Geng Man [5105 3355], et al., of Southwestern Institute of Physics, Leshan, Sichuan]

[Text] Ion implantation equipment, the LZ-50, has been built for ion implantation applications to the improvement of properties of non-semiconductor materials. The beam energy is 80 keV, nitrogen ion current 10 mA, and implantation area up to 200 cm². The equipment is

characterized by high stability and good reproducibility, and can be operated in steady state. It has been used to perform experiments on ion implantation for carbide alloys, tool steel, titanium alloys, ceramics and other non-ferrous metals. Some good results in industrial applications have been obtained. For example, the lifetime of Co-WC clamped indexable inserts used in manufacturing has been lengthened by a factor of 2-4.

09717/06662

First Chinese-Made Industrial Robot Operational
40080045c Beijing RENMIN RIBAO (Overseas Edition)
in Chinese 19 Dec 87 p 1

[Article by correspondent Zhao Mingliang [6392 2494 0081] of Xinhua, Beijing 18 Dec 87: "Domestic Robot Production Realized"]

[Text] After an operator issues instructions from the keyboard, the orange colored robot turns and stretches its arms to perform a welding demonstration with precision and speed.

This robot, Smelter 1, was certified at the ministry level today.

Automatic control experts at the review pointed out that Smelter 1 is the first robot completely made in China. The control software and some hardware of the 100 or so robots produced before were imported. After 4 years of hard work by the researchers at the Beijing Institute of Steel, the hardware, software and vibration-control systems are all made domestically.

It is reported that all technical specifications of Smelter 1 have reached the same level as those of comparable products in the world in the 1980's. It fills a void in industrial robot control systems.

According to the introduction, Smelter 1 has man-machine dialogue capability by way of the keyboard. It can be operated by all workers.

12553/12232

Nuclear Blast-Resistant Doors
40081046 Beijing KEJI RIBAO [SCIENCE AND TECHNOLOGY DAILY] in Chinese 29 Dec 87 p 1

[Summary] An arched protective door made of steel-reinforced concrete made by the Air Force Engineering and Design Bureau has proven to be highly resistant to nuclear blast, taking pressures of 80 kg/cm² after 1,000 tests. The doors have the superior characteristics of being blast-proof, and easily opened and closed. The doors are equipped with automatic and remote-control systems, and are highly suited as protective equipment for military installations. They are also useful in civil applications, such as banks, and other vaulted storage facilities.

/06662

Breakthrough in Superconductor Study Noted
40080063 Beijing GONGREN RIBAO in Chinese
2 Jan 88 p 1

[Report by Reporter Dong Yuqin [5516 3768] and Correspondent Liu Gang [0491 0474]: "China Makes Important Breakthroughs in the Study of Superconductors"]

[Excerpts] Two units of our Ministry of Nuclear Industry, through cooperation in an experiment, have recently made an important breakthrough in the phenomenon of room-temperature superconductivity that thousands upon thousands of physicists in the world are vying with each other to discover.

Each of the three collections of yttrium-barium-copper-oxide specimens successively manufactured and prepared by the Beijing Institute of Applied Physics and Computational Mathematics of the Ministry of Nuclear Industry in the past 3 months through cooperation with the No 903 Factory contain about 10 percent good specimens. Some of them, after being stored for 40 days, still show the following phenomena of superconductivity under 290 K to 300 K, or indoor temperature conditions: When charged with a given amount of direct current, a specimen shows no voltage. When charged with radio-frequency current, it shows direct current voltage. The effect that these superconductors exhibit is what international scholars call the Josephson effect.

In February last year, Professor Zhu Jingwu of Houston University and Zhao Zhongxian of the Institute of Physics under the Academy of Sciences of China, and others separately successfully discovered superconductivity phenomena under liquid-nitrogen temperature conditions, raising the temperature once to around 90 K. By raising superconductivity phenomena in a liquid-nitrogen temperature to indoor temperature conditions, the scientists of our Ministry of Nuclear Industry have held out broad prospects for mankind's use of superconductive material.

08309

Harbin Polytechnical University Develops Printed-Chinese-Character Recognition System
40080055 Beijing JISUANJI SHIJIE in Chinese
6 Jan 88 p 32

[Summary] An integrated real-time system for recognizing the national-standard second level (6,763) of printed Chinese characters, developed by the Information-Processing and Pattern-Recognition Teaching and Research Section(s) of Harbin Polytechnical University, has recently undergone evaluation. The system uses a Japanese Ricoh FX-120 facsimile machine as the character image input device, and an originally designed special-purpose FX/PC input interface connected with an IBM

PC/XT microcomputer. According to statistical pattern-recognition principles, the following information is gathered and processed: the character's rough outer contours are scanned, followed by a determination of the numerical value of the projection of the character on the X and Y axes via the WALSH transform; these two features are then combined. Through CCDOS, the result can then be displayed on a CRT or printed out, as well as stored on disc, and can be edited.

Numerous tests have shown the system's recognition rate of #2 imitation-Song-dynasty-typeface characters is greater than 99.5[&], recognition time (including character input, line segmentation, character segmentation, and identification) is 2.98, seconds per characters. The system's most important characteristics are: it resists noise, strongly resists displacement, and can recognize flawed characters.

The evaluation committee rated its performance in terms of individual numbers of characters recognized and recognition rate as meeting advanced domestic standards.

[Editorial note: this system is an obvious improvement over the "Experimental System of Printed Chinese Character Recognition" published by four Qinghua University scientists in DIANZI XUEBAO (Acta Electronica Sinica), Vol 15, No 5, Sep 87, pp 1-7. According to the abstract of the earlier system, "a set of structural characteristics (peripheral feature, local patterns, end points and cross points of strokes) is defined and used for pre-classification and matching. . . . Experiment shows that the correct recognition rate is better than 98..."]

/12223

Baiyuneboite-(Ce)—A New Mineral
40090051a Guizhou KUANGWU XUEBAO [ACTA
MINERALOGICA SINICA] in Chinese
Vol 7 No 4, Dec 87 pp 289-297

[English abstract of article by Fu Pingqiu [0265 1627 4428] of the Institute of Geochemistry, Chinese Academy of Sciences, Guiyang; Su Xianze [5685 6343 3419] of the Third Institute, State Bureau of Oceanography, Xiamen]

[Text] The mineral occurs in niobium rare-earth ores of eh dolomite type, sometimes with strong soda-pyroxenization in Bayon Obo. It is associated with soda-pyroxene, riebeckite, bafertisite, bastnaesite, etc.

It usually occurs in the form of irregular grains, and sometimes in the form of thin hexagonal tablets. It is yellow with white streaks, and greasy to adamantine in luster. Transparent. Non-fluorescent. $H = 4.5$. Cleavage (001) perfect. Fracture conchoidal. D (meas) = $4.30(11)$ g/cm^3 , D (calc) = 4.45 g/cm^3 . Uniaxial(-), $N_o = 1.7450(5)$, $N_e = 1.5990(5)$ (589 nm). Pleochroism $N_o =$ pale greenish, $N_e =$ pale brownish yellow.

It has been studied by electron diffraction and high resolution electron microscopy. The crystal structure model determined from X-ray diffraction analyses has been verified by comparing its projection direction with the image.

It is a Na-Ba rare-earth fluo-carbonate that has been discovered for the first time in China. All other similar minerals contain almost no Na. Some of its physical properties and X-ray powder data are similar to those of cordylite, but the structure and chemical composition distinguish it from the latter. The mineral was named after its occurrence, in conformity with the Levinson nomenclature for rare-earth minerals.

9717/12232

Crystal Structure of Baiyuneboite-(Ce)
40090051b Guizhou KUANGWU XUEBAO [ACTA
MINERALOGICA SINICA] in Chinese
Vol 7 No 4, Dec 87 pp 298-304

[English abstract of article by Fu Pingqiu [0265 1627 4428], et al., of the Institute of Geochemistry, Chinese Academy of Sciences, Guiyang; Shao Meicheng [6730 5019 2052] of Beijing University; Qian Jinzi [0578 6855 1311] of the Institute of Physics, Chinese Academy of Sciences, Beijing]

[Text] Baiyuneboite-(Ce) " $NaBaCe_2[F/(CO_3)_4]$ " is of a hexagonal system. The space group is $P6_3/mmc$, with $a = 5.0875(15)$ o/A, $c = 23.1680(1)$ o/A, $Z = 2$. The intensity data for this mineral were collected with a fully automatic four-circle X-ray diffractometer. The procedure

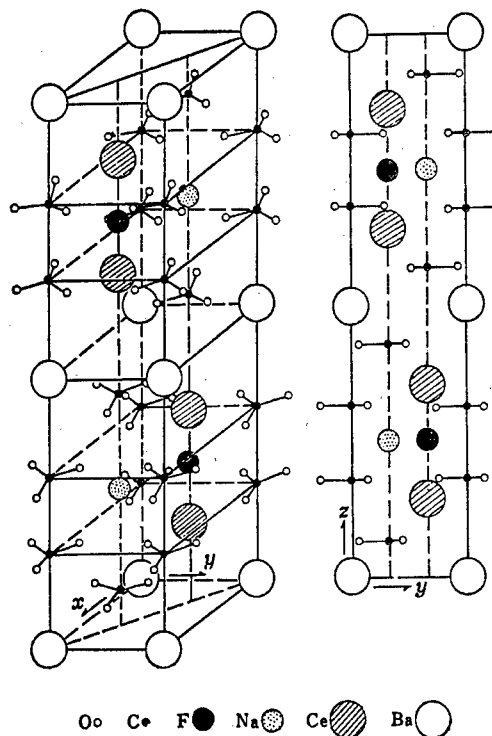

The crystal structure of baiyuneboite-(Ce)

"SHELXTL" was used to determine the crystal structure of the mineral. Its temperature factor and coordination parameters were corrected, giving $R = 0.049$.

The authors compared the crystal structure determined here with that determined by Ofedal, and found that they are completely different. The relationships between the crystal morphology, major physical and optical properties, IR absorption spectrum and crystal structure of this mineral are also discussed.

9717/12232

Zincovoltaita—A New Sulphate Mineral
40090051c Guizhou KUANGWU XUEBAO [ACTA
MINERALOGICA SINICA] in Chinese
Vol 7 No 4, Dec 87 pp 307-312

[English abstract of article by Li Wanmao [2621 8001 5399], et al., of the Department of Geology, Lanzhou University]

[Text] Zincovoltaita is a new K-, Zn-, Fe- and Al-bearing sulphate mineral discovered in the oxidation zone of a Pb-Zn deposit at Xitieshan, Qinghai Province, China. Associated minerals include romerite, melanterite, gypsum, quartz, pyrite, etc.

The mineral occurs as grains or granular aggregates. Individual grains are usually 1-2 mm. Monocrystals are common. General forms include: o(111), c(100), d(110) and n(211). Green-black to oil-green with a gray-green streak. Pitchy to resinous luster. Opaque to translucent. $H = 3.0$. Brittle, cleavage absent. Conchoidal fracture. Density (meas) - 2.756 and density (calc) - 2.767. Optically isotropic, $N = 1.605(3)$. It is of a cubic system. Space group $Fd\bar{3}c$, $a = 27.280$ o/A, $Z = 16$. The strongest lines in the diffraction pattern of the mineral are: 5.54(48), 4.26(28), 3.53(67), 3.39(10), 3.13(39), 3.03(28)

and 2.84(32). The simplified formula is $K_2Zn_5Fe_{3/3+Al}(SO_4)_{12} \cdot 18H_2O$. DTA curve shows two strong endothermic peaks at 249 and 702 degrees C, and two weak peaks at 278 and 826 degrees C. IR absorption curve has two principal absorption bands at 3402-3065 and 1138-1004 cm^{-1} and three subordinate bands at 1686-1637, 625-590 and 442 cm^{-1} .

The mineral is named after its composition.

9717/12232

Investigation of Outbreak of Epidemic Non-A, Non-B Hepatitis in Duolu Township, Luopu County, Xinjiang Autonomous Region

40091035 Beijing JIEFANGJUN YIXUE ZAZHI
[MEDICAL JOURNAL OF CHINESE PEOPLE'S
LIBERATION ARMY] in Chinese
Vol 12 No 6, Dec 87 pp 412-414

[English abstract of article by Wang Mingyi [3769 2494 5030], et al., of the Military Medical Institute, Logistic Department, Wulumuqi Military Command; Tian Xin [3944 6580], et al., of the Institute of Microbiology and Epidemiology, Academy of Xinjiang Medical Sciences]

[Text] An outbreak of viral hepatitis occurred in Duolu Township, Luopu County, Xinjiang Autonomous Region, between August 1986 and May 1987. The total population in the area was 21,958. During the outbreak, there were 9,371 patients with acute hepatitis, 47 of whom died (20 were pregnant women). Of 125 serum samples from patients with acute hepatitis tested (RIA) for the markers of HAV and HBV, 108 were negative for anti-HAV IgM, HBsAg and anti-HBc IgM. This epidemic mostly affected young adults. The incidence of the disease was significantly lower (4.8 percent) in people who usually drank tap water as opposed to people who usually drank water from irrigation channels or pools (28.2 percent). The results suggest that contaminated water was responsible for the epidemic. Virus-like particles (23-30 nm) were found by IEM in four stool samples from the patients with acute hepatitis. Whether these particles were the etiological agent of this epidemic requires further confirmation.

9717/12232

Establishing Monoclonal Anti-PreS2 Cell Line, Uses of Antibody in Detection of PreS2 Antigen

40091032 Beijing BEIJING YIKE DAXUE XUEBAO
[JOURNAL OF BEIJING MEDICAL UNIVERSITY]
in Chinese Vol 19 No 5, Oct 87 pp 295-298

[English abstract of article by Xia Mengqi [1115 1322 3825], et al., of the Institute of Hepatology]

[Text] After successful fusion of spleen cells immunized with polymerized human serum albumin receptor (PHSA-R) activity positive HBV particles to myeloma cells (sp2/0), a stable monoclonal antibody (McAb) cell line was established. The McAb was identified as specific for the PreS2 antigen of HBV. Since it can inhibit the PHSA-R activity on HBV, it probably is an antibody against PHSA-R of PreS2. This Mc-anti-PreS cell line is the first one reported in China. With this McAb, the authors developed a hemagglutination assay for the PreS2 antigen. The hemagglutination titers of Mc-anti-PreS2 sensitized sheep red blood cells (SRBC) were closely related to those of PHSA cells. The average hemagglutination titer of the PreS2 antigen was higher in the HBeAg positive sera than in the HBeAg negative sera. In the HBeAg positive sera, titers of the PreS2

antigen were correlated with those of HBsAg, but not parallel to those of HBeAg. It is suggested that, in some cases, PreS2 and HBeAg cannot be used as substitutes for each other, although both antigens are thought to be indicators of active replication of HBV DNA.

9717/12232

Esophageal Cancer Diagnostic, Treatment Tool Developed

40081042a Beijing RENMIN RIBAO in Chinese
12 Oct 87 p 3

[Article by Liu Wei [0491 1550]: "Another Biological Minimissile. Immunophotosensitizer Undergoes Appraisal"]

[Text] An immunophotosensitizer developed by the PLA General Hospital provides a new biological missile for the early diagnosis of esophageal tumors and for improving therapeutic results. On the eve of the national anniversary, this immunophotosensitizer underwent appraisal.

How to improve the early detection of cancer and bolster the therapeutic effectiveness of anti-cancer drugs while reducing toxic reactions has consistently been a topic for research by medical circles both inside China and abroad. Researchers inside and outside China are bending efforts to use anti-tumor antibodies as vectors for anti-cancer substances, i.e., "biological minimissiles" for the diagnosis and treatment of cancer.

The immunophotosensitizer developed by the PLA General Hospital links together hematoporphyrin and anti-CEA antibodies to form a coupler that possesses both the affinity for cancer cells of monoclonal antibodies and the killing and crippling effect on cancer cells of hematoporphyrin. The reaction produced by this coupler causes the monoclonal antibodies to hone in on target areas like a guided missile, accurately carrying the hematoporphyrin in a set direction to the tumor cells. If a laser is sent to the cancer cells via an optical fiber endoscope, when it strikes the hematoporphyrin on the cancer cells, it will fluoresce with an orange-red color, indicating the tumor location like an indicator light, and it can kill the tumor cells without damaging normal cells.

The PLA General Hospital has used the completion of the immunophotosensitizer preparation as a foundation for its current study of its internal and clinical application.

9432

New Clues Found in Genetic Code Translation Method

40081042c Beijing GUANGMING RIBAO in Chinese
23 Oct 87 p 1

[Article by Correspondent Liu Lusha [0491 6424 3097]: "DNA Protein Selective Toward Messenger RNA. New Clues Provided in Revealing the Role of DNA in Translating Genetic Codes. New Discoveries in the Study of Genetic Theories by Tong Kezhong [4547 0344 1813] and Others."]

[Text] The task force headed by Tong Kezhong in the Genetics Institute of the Chinese Academy of Sciences has discovered after many years of research that DNA proteins function selectively toward messenger RNA, providing new clues for revealing just how DNA translates genetic codes.

Biological genetic information is coded through different nucleotide sequences, which are stored in deoxyribonucleic acid (DNA), which must be first transcribed into ribonucleic acid (messenger RNA) genetic information, and then be translated to guide amino acids according to a certain sequential arrangement to form different proteins that produce the myriad rich and varied forms of the living world. The protein in all living things is compounded on ribosomes, and ribosomes are devices for translating genetic codes. People have already learned that ribosomes are collections of large molecules made up of three kinds of RNA and more than 50 kinds of protein, and virtually everything is known about the precise functioning of this RNA and protein in the translation process.

In 1979, Tong Kedong and others began the isolation and authentication of variants of the various kinds of ribosome proteins. During the past several years, they have isolated and authenticated 27 kinds of ribosome protein mutants in *Bacillus subtilis*, and 24 ribosome protein mutants in *E. coli*, and they have observed the effects of these mutants on the genetic expression of *Bacillus subtilis* and *E. coli*, as well as on their bacteriophages. They have consequently discovered that mutations of different ribosome proteins have a different effect on the translation efficiency of the same gene. Some cause a rise in translation efficiency by a maximum of sixfold, while some cause translation efficiency to decline, the lowest reaching less than 1 percent. In addition, they discovered that the same ribosome protein mutant has a different effect on the translation efficiency of different genes. This shows a selectivity toward messenger RNA on the part of the ribosome protein in the genetic code translation process that can adversely affect gene expression.

Though long and arduous research will be required to gain a full understanding of the specific functioning of ribosomes in the translation process as well as why they function in this way, the present research has allowed people to understand for the first time one aspect of the

functioning of ribosome proteins. The noted geneticist, Professor Tan Jiazhen [6151 1367 2823] believes this is a pioneering research achievement.

9432

Infantile Hepatitis Syndrome, Cytomegalovirus Infection

40091036b Shanghai ZHONGHUA CHUANRANBING ZAZHI [CHINESE JOURNAL OF INFECTIOUS DISEASES] in Chinese Vol 5 Nov 4, Nov 87 pp 198-201

[English abstract of article by Lu Shengmin [0712 4939 2404], et al, of the Third Hospital, China Medical University, Shenyang]

[Text] a virological study of 182 infants suffering from HBsAg negative infantile hepatitis syndrome with jaundice, hepatosplenomegaly and a high level of SGPT was conducted. Of these cases, 92 (50.55 percent) were found cytomegalovirus (CMV) positive by viral isolation and/or serologic testing. CMV could be isolated from the saliva and breast milk as well as the urine. It was demonstrated that the secretion of CMV in urine might persist for a long time and might be intermittent. CMV was isolated from a liver biopsy and an autopsy liver specimen of infants suffering from biliary atresia, thereby proving the inflammatory theory of biliary atresia. These findings illustrate that biliary atresia might develop during infantile hepatitis. In addition, CMV was also isolated from the liver biopsy of another infant suffering from a choledochal cyst, indicating a close relationship between CMV hepatitis and choledochal cysts.

09717/06662

Liver-Specific Circulating Immune Complex in Rival Hepatitis B

40091036c Shanghai ZHONGHUA CHUANRANBING ZAZHI [CHINESE JOURNAL OF INFECTIOUS DISEASES] in Chinese Vol 5 No 4, Nov 87 pp 202-205

[English abstract of article by Liu Zuchong [0491 4371 1504], of the Viral Hepatitis Research Institute, The Second Hospital, Chongqing University]

[Text] Anti-LSP-IgG was prepared from rabbit antiserum against LSP which was isolated from human embryonic liver and purified with the affinity chromatographic technique. Using the ELISA detection system and anti-LSP-IgG as the coated antigen, the circulating immune complex IC_{LSP} was studied in 94 patients with various types of viral hepatitis B.

The IC_{LSP} content was increased in the serum of fulminant and chronic active hepatitis, and the percentage of positive IC_{LSP} was found to be higher than that of positive IC_{HBs}. It was also found that the complement fraction 3 was consumed in the IC_{LSP} positive cases. It seems that IC_{LSP} plays an important role in eliciting

protracted deterioration in fulminant hepatitis and subacute liver necrosis. The IC_{LSP} may be the result of liver tissue damage from which the LSP has penetrated into the blood.

09717/06662

Investigation of Anti-HAV, Its Changes in Acute Viral Hepatitis Serum by Double Sandwich ELISA Method

40091036d Shanghai ZHONGHUA CHUANRANBING ZAZHI [CHINESE JOURNAL OF INFECTIOUS DISEASES] in Chinese Vol 5 No 4, Nov 87 pp 206-209

[English abstract of article by Shang Shouli [1424 1343 4409], et al., of the Department of Infectious Disease, Shandong Medical University]

[Text] An anti-HAV IgM test kit was prepared using HAV cultured in a diploid cells from human fetal lung as the antigen, commercial purified horse to human IgM as the capture antibody, purified serum from patients with hepatitis A (HA) in convalescence as the specific antibody and an enzyme labeled with sodium periodate and PPD as the substrate. A method for determining the anti-HAV IgM with the ELISA "sandwich" technique was established. The test showed that the 44 patients with HA in the epidemic area were positive, 30 patients with epidemic hemorrhagic fever were negative and 30 of the 100 inpatients with acute viral hepatitis were positive. A patient with HA was longitudinally followed up. It was found negative 40 days before the onset of the disease and positive at 1 week and 1 month following onset of the illness. The antibody titer increased up to 10^{-7} , was markedly decreased at 2 months following onset of the disease, and turned negative at 40 months. The technique was found to be highly sensitive, reproducible and stable, is beneficial for the early diagnosis of HA.

09717/06662

Blood Vessel Contracting Agent Isolated From Leukocytes

40081042d Beijing GUANGMING RIBAO in Chinese 18 Nov 87 p 1

[Article by Correspondent Liu Lusha [0491 6424 3097]: "China Extracts Blood Vessel Tonic II [Tonica vaculares II] from Leukocytes; Of Major Importance in Diagnosis and Treatment of High Blood Pressure and Other Diseases"]

[Text] On 17 November, Professor Wang Jiarui [3076 1367 3843] of the Xuanwu Hospital of the Capital Medical Academy announced the extraction for the first time anywhere of a sample of blood vessel tonic II from leukocytes.

Until now, people have maintained that blood vessel tonic II, which has a powerful effect on contraction of the blood vessels, played a major role in the pathogenesis of high blood pressure, and that production of blood vessel tonic II relied, in turn, on the presence of renin. However, in recent years, numerous phenomena have suggested that blood vessel tonic II may have another source. In 1982, American scientists discovered a new enzyme in leukocytes, and these enzymes were able to produce blood vessel tonic II in vitro experiments. However, because testing techniques for minute amounts of blood vessel tonic II had not been worked out, it remained impossible to find blood vessel tonic II in leukocytes.

Researchers Wang Jiarui and Yu Zhongyuan [0060 0112 0337] of Xuanwu Hospital's high blood pressure laboratory worked for more than 3 years, combining highly effective liquid phase chromatography with radiation immunology techniques to solve the difficult problem of testing the minute physiological levels of blood vessel tonic II. They applied these methods successfully to the isolation from human leukocytes of samples of blood vessel tonic II, which is active in the contraction of blood vessels and in the immunity of organisms.

This important discovery demolished people's traditional understanding of leukocytes and showed that leukocytes are not only an integral part of the human body's defensive system, but also play a role in regulating the action of blood vessels. This will produce important effects on leukocyte physiological and pathological research, and on blood vessel action regulation theories. This discovery also holds important theoretical and practical value for the diagnosis and treatment of high blood pressure, coronary heart disease and myocardial infarctions.

9432

Research Underway to Develop Monoclonal Antibody-Secreting Hybridoma

40081042e Beijing KEJI RIBAO [SCIENCE AND TECHNOLOGY DAILY] in Chinese 13 Oct 87 p 1

[Article by Liu Zhengqin [0491 2973 2953] and Tang Guoxing [3282 0948 2502]: "First Strain of Human Bone Marrow Cancer Cells Established in Academy of Medical Science Blood Transfusion Institute. Holds Major Significance For the Study of Biology, Genetics, and Cellular Immunity"]

[Text] China's first strain of human bone marrow cells were recently established in the Chinese Academy of Medical Science's Blood Transfusion Institute. Experts believe that the establishment of human bone marrow cell strain IBTCHM 8310 creates fine conditions for China to engage in research on human lymphocyte hybridomas, and to do research and development as well as produce monoclonal antibodies of human origin.

The establishment of a human bone marrow cancer cell strain is indispensable to the development of human to human hybridoma research. In October 1982, assistant researcher Comrade Cun Heng [1407 3801] of the Chinese Academy of Medical Science's Blood Transfusion Institute isolated and cultured a human bone marrow cancer cell strain. Following 4 years of in vitro culturing of successive generations, its biological characteristics have been stabilized, and preliminary tests show it is able to fuse with human lymphocytes to form a human to human lymphocyte hybridoma that can secrete monoclonal antibodies. All the hybridomas produced have retained their function of secreting antibodies after the culturing of 20 successive generations, thus demonstrating that this cell system has practical possibilities for use in human to human hybridoma production of monoclonal antibodies of human origin.

9432

Fetal Liver Cell Treatment of Leukemia, Aplastic Anemia

40081042b Beijing PEOPLE'S DAILY [OVERSEAS EDITION] in Chinese 17 Dec 87 p 4

[Article: "China Uses Fetal Liver Cell Transplants To Treat Blood Diseases. Some Seriously Ill Patients on the Verge of Death Recover a New Life"]

[Text] Xinhuashe, Beijing, 15 Dec. Chinese military medical researchers have scored heartening advances in the use of fetal cell transplants and injection methods in the treatment of blood diseases such as leukemia and aplastic anemia. Numerous seriously ill patients on the verge of death have recovered a new life.

Leukemia and aplastic anemia result from the obstruction of blood production brought about by abnormalities in the body's blood producing cells that leads to a degeneration or loss of their blood production function. Nearly 1 million people throughout the world die from these ailments each year.

During the 1960's, Chinese military medical researchers began to use fetal liver cell transplants and infusion methods in research on the treatment of leukemia and aplastic anemia. They transplanted and injected the blood producing cells from fetal livers into patients where they became active and replaced the existing, abnormal blood producing cells, reviving the patients' blood producing functions. After more than 20 years of study, this research has been used successfully in clinical treatment.

According to the person in charge of this research, Wu Zuze [0702 4371 3419] of the Radiation Medicine Institute of the Military Medical Academy, the blood producing function has been restored in most of the 23 leukemia patients who received fetal liver cell transplants, and in most of the 701 aplastic anemia patients who received fetal liver cell injections. Eight of the

leukemia patients are still alive after more than 2 1/2 years, and 74.9 percent of the aplastic anemia patients have been basically cured and are on the mend.

Wu Zuze said the use of fetal liver in curing illnesses holds great promise. Today, the clinical use of fetal liver injections has already gone beyond the realm of treating illnesses due to obstruction of the blood producing function, expanding into the treatment of diseases such as acute severe hepatitis. This study will lay a foundation for the future application of gene engineering techniques to the in vitro production of these kinds of blood producing regulatory substances.

9432

Establishment of Filler-Cell Free Single T Cell Culture System With High Cloning Efficiency

40091038a Beijing ZHONGHUA WEISHENGWUXUE HE MIANYIXUE ZAZHI [CHINESE JOURNAL OF MICROBIOLOGY AND IMMUNOLOGY] in Chinese Vol 7 No 6, Dec 87 pp 348-352

[English abstract of article by Chen Weifeng [7115 1983 1496] and K. Shortman of the Department of Microbiology and Immunology, Beijing Medical University]

[Text] A filler-cell free single T cell culture system has been established. The cloning efficiency for mature T cells in murine lymph nodes, cortisone-resistant thymocytes and Thy-1⁺Ly2⁻L3T4⁻ early T cells in murine thymuses cultured in this system was 89 percent, 86 percent and 60 percent, respectively. The clone size for those subpopulations was an average of 51, 50 and 38 cells per clone when scored on day 4 of the culture. The critical composition of the system included the utilization of PMA plus ionomycin as stimuli, and was supplemented with cytokines of IL2 as well as CAS. Both IL2 and undefined factors present in CAS have been found to be the key cytokines in the triggering of PMA and Ionomycin-induced blast cells entering the proliferative process. Other factors, such as IL1, IL3, IFN γ , GM-CSF and lactate were shown to have weak stimulation effects, which was clearly manifested in the expansion of the clone size when coupling with IL2. The proportion of progeny cells expressing mature T cell markers (Ly2 or L3T4) varied between clones. The advantages of the system are discussed.

9717/08309

Study of Gene for Membrane Protein of Enterobacteria. III. New Lipoprotein Gene of Escherichia Coli

40091038b Beijing ZHONGHUA WEISHENGWUXUE HE MIANYIXUE ZAZHI [CHINESE JOURNAL OF MICROBIOLOGY AND IMMUNOLOGY] in Chinese Vol 7 No 6, Dec 87 pp 353-356

[English abstract of article by Huang Yaoxuan [7806 5069 3551], et al., of the Institute of Hepatology, Beijing Army General Hospital]

[Text] The major outer membrane lipoprotein (Lpp) of *E. coli* is an abundant and extensively studied structural protein. It provides an excellent model system for the study of membrane biogenesis and protein secretion. It is produced from a secretory precursor and has a peculiar amino terminal structure. It is assumed that the DNA sequences of the lipoprotein genes surrounding the signal peptide cleavage site are homologous and will hybridize. The authors have purified a DNA fragment, about 100 bp in length, which covers the region of the entire signal peptide, and have used it as a probe to hybridize restricted enzyme digest of the total chromosomal DNA from *E. coli* JE 5506 (lpp⁺) and JE 5505 (lpp⁻) at 20°C for 2 days. In addition to the 10Kb HindIII fragment from *E. coli* JE 5506, the authors found two HindIII fragments from both strains were hybridized with the ³²P-labeled probe. One of them (25Kb) was cloned in the pBR 322 plasmid. It was found that the PAGE mobilities of the protein produced by the clones corresponded to that of lpp. In addition, globomycin also caused the accumulation of the precursor and, when a portion of solubilized membrane protein was treated with anti-lpp serum, an immunoprecipitate was formed. From the results mentioned above it can be concluded that the gene discovered is a new lipoprotein gene, and it may be the second gene of lpp.

9717/08309

Bivalent Strain With Characteristics of *Shigella Flexneri* 2a, *Sonnei*

40091038c Beijing ZHONGHUA WEISHENGWUXUE HE MIANYIXUE ZAZHI [CHINESE JOURNAL OF MICROBIOLOGY AND IMMUNOLOGY] in Chinese Vol 7 No 6, Dec 87 pp 373-377

[English abstract of article by Wang Bingrui [3769 4426 3843], et al., of Lanzhou Institute of Biological Products, Ministry of Public Health]

[Text] An avirulent bivalent strain with both *Shigella flexneri* 2a and *Shigella sonnei* characteristics has been obtained by transferring the large plasmid encoding form I antigen of *Shigella sonnei* into the recipient T32-Istrati strain, which is a vaccine strain used in Romania.

The bivalent strain obtained has been investigated for its stability, immunogenicity, biochemical characteristics, safety and plasmid profiles. The results revealed that the dissociation rate of this bivalent strain from the loss of the form I antigen was much lower than that of its parent strain. The dissociation rate of the bivalent strain was about 2 percent, while that of the parent *Shigella sonnei* strain was 22.4 percent. It maintained the agglutinating properties with both anti-flexneri 2a and sonnei serum after 36 passages (more than 36 passages has not been tested). When challenged with virulent *Shigella* 2a and sonnei strains on monkeys (*Macaca mulatta*), it provided an 80 percent protection rate against *Shigella sonnei* and 70 percent against flexneri 2a. Plasmid

profiles showed that the bivalent strain possessed the 120 Md plasmid of *Shigella sonnei* in addition to the original 105 Md plasmid of the recipient. The uses for this strain are discussed.

9717/08309

Studies of Meningococcal Polysaccharide-Tetanus Toxoid Conjugates

40091038d Beijing ZHONGHUA WEISHENGWUXUE HE MIANYIXUE ZAZHI [CHINESE JOURNAL OF MICROBIOLOGY AND IMMUNOLOGY] in Chinese Vol 7 No 6, Dec 87 pp 383-386

[English abstract of article by Guo Yuyi [6753 6276 6146], et al., of Shanghai Institute of Biological Products]

[Text] Meningococcal group A polysaccharide is known to be a poor immunogen in very young children. The ability of a polysaccharide-protein conjugate to increase the immunogenicity of bacterial capsular polysaccharide has been well documented. Accordingly, a method has been presented for covalently coupling the meningococcal group A capsular polysaccharide to tetanus toxoid.

In this paper, the authors examine the immunogenicity of the conjugate in guinea pigs and mice. The polysaccharide-protein conjugate induced serum antibodies against both the polysaccharide moiety and the tetanus toxoid moiety of the conjugate. These antibodies were mainly of the IgG class. In contrast to the poor immunogenicity of the purified polysaccharide in the animals, the conjugate induced high levels of the anti-Ps antibody, having bactericidal activity. The antibody response in mice was related to the dose of the conjugate, increasing with the number of injections. It is proposed that the polysaccharide component of the conjugate be converted into a thymic-dependent immunogen.

9717/08309

Studies of Kinetics of Protein Synthesis Inhibition in Targeting Cells by Immunotoxin

40091038e Beijing ZHONGHUA WEISHENGWUXUE HE MIANYIXUE ZAZHI [CHINESE JOURNAL OF MICROBIOLOGY AND IMMUNOLOGY] in Chinese Vol 7 No 6, Dec 87 pp 392-395

[English abstract of article by Shen Beifen [3088 0223 1164], et al., of the Institute of Basic Medical Sciences, Academy of Military Medical Sciences, Beijing]

[Text] Kinetic data on protein synthesis inhibition by Ricin and antibody-Ricin conjugates have been used to assess the various factors which affect their cytotoxicity.

The time required to reduce protein synthesis by 90 percent, denoted T₁₀, was 2.81 (plus over minus) 0.41 hours with Ricin and 29.13 (plus over minus) 4.70 hours

with H65:Ricin on Molt-4 human T leukemia cells. The results show that the inhibition rate induced by the immunotoxin was much slower than that induced by Ricin alone. Lysosomotropic amines, such as ammonium chloride, known to interfere with the uptake of certain macromolecules, did not increase the sensitivity of Molt-4 cells to H65:Ricin.

The different methods used for preparing the immunotoxin could affect the cytotoxicity against targeting cells.

9717/08309

Prevention of Perinatally Transmitted Hepatitis B Virus Infections With Hepatitis B Immunoglobulin, Hepatitis B Vaccine

40091038f Beijing ZHONGHUA WEISHENGWUXUE HE MIANYIXUE ZAZHI [CHINESE JOURNAL OF MICROBIOLOGY AND IMMUNOLOGY] in Chinese Vol 7 No 6, Dec 87 pp 396-399

[English abstract of article by Kang Yong [1660 1661], et al., of China College of Medical Sciences, Shenyang, etc.]

[Text] Prevention of perinatally transmitted hepatitis B virus infections with hepatitis B immunoglobulin (HBIG) and hepatitis B vaccine (HB-vaccine) was conducted in Shenyang, China. Infants born to e-antigen-positive HBsAg carrier mothers were observed in two groups. The first group was given HBIG (400 IU/ml/dose, produced by Tianjin Blood Center, Lot No 830919) within 48 hours following birth, and then injections of the HB-vaccine were administered at the end of 1, 2, and 6 months after birth. Each dose of the HB-vaccine (Lot No 83-1) was 30 micrograms, plasma derived and produced by the National Vaccine and Serum Institute, Beijing. The vaccine was injected intramuscularly at the upper arm. The second group served as the control. The results showed persistent HBs antigenemia developed in 7.14 percent (3/42) of the infants receiving prophylaxis, as compared with 89.34 percent (53/59) in the control. The difference was statistically significant (P 0.001). The protective efficacy was 91.99 percent.

9717/08309

Study of Relationship Between Gamasid Mites, Epidemic Hemorrhagic Fever

40091037a Beijing ZHONGHUA LIUXINGBINGXUE ZAZHI [CHINESE JOURNAL OF EPIDEMIOLOGY] in Chinese Vol 8 No 6, Dec 87 pp 333-335

[English abstract of article by Wu Guanghua [0702 0342 5478], et al., of the Institute of Military Medicine, Nanjing Command, PLA]

[Text] In order to explain the routes of transmission of epidemic hemorrhagic fever (EHF), the authors conducted a series of studies on the relationship between the

gamasid mites and EHF. The results indicate that *Haemolaelaps glasgowi* and *Eulaelaps stabularis* are the dominant species in the litters of *Apodemus agrarius*—the main reservoir of EHF. Their seasonal distribution has been correlated with the incidence of human EHF, they can pierce the normal skin of rodents and humans to suck blood and they can naturally be infected by the EHF virus. It was also found that the EHF virus could be transmitted through the bite of mites among rodents and through transovarial transmission in mites, and the antigenicity of the EHFV isolated from mice and mites was identical. These results indicate that these two mites can serve as the transmitting vector of the field-rodent-type of EHF, and may act as a reservoir host as well.

9717/08309

Experimental Study of Biting, Transstadial, Transovarian Transmission of Epidemic Hemorrhagic Fever Virus by Gamasid Mite *Ornithonyssus Bacoti*

40091037b Beijing ZHONGHUA LIUXINGBINGXUE ZAZHI [CHINESE JOURNAL OF EPIDEMIOLOGY] in Chinese Vol 8 No 6, Dec 87 pp 336-338

[English abstract of article by Zhuge Hongxiang [6175 5514 3163 4382], et al., of the Department of Parasitology, Suzhou Medical College]

[Text] The identified epidemic hemorrhagic fever virus (EHFV) strain Su-163 was first inoculated into suckling mice, then nymphs and adults of gamasid mites (*Ornithonyssus bacoti*) were permitted to bite the infected mice. On the 10th, 15th and 25th days, these mites and their second generation protonymphs were permitted to bite healthy suckling mice. The EHF antigen was tested with the indirect immunofluorescent technique. It was shown that the specific fluorescence granules were detected in all of them, except for the group of second generation protonymphs on the 10th day, while in the control and suckling mice groups the reovirus types I and II were all negative and the specific fluorescence reaction could be blocked by the EHFV immuno-serum.

Therefore, the authors provide evidence for the first time that *O. bacoti* can transmit EHFV not only through biting, but also through transstadial and transovarian means. The virus can survive in the mites for at least 25 days. Since *O. bacoti* is the predominant species on rats and mice, is widely distributed, numerous and exclusively hemophilic, and its seasonal fluctuation conforms with the incidence of human EHF, the authors believe that it may be the vector and reservoir of both urban and laboratory animal types of EHF.

9717/08309

Antimicrobial Resistance of *S. Typhi*, Outbreak of Typhoid Fever

40091037c Beijing ZHONGHUA LIUXINGBINGXUE ZAZHI [CHINESE JOURNAL OF EPIDEMIOLOGY] in Chinese Vol 8 No 6, Dec 87 pp 340-342

[English abstract of article by Zheng Qingsi [6774 1987 2448], et al., of the Institute of Epidemiology and Microbiology, Chinese Academy of Preventive Medicine, Beijing]

[Text] This paper reports the results of antimicrobial resistance pattern plasmid profiles and conjugative R plasmid of 93 *S. typhi* isolates. All strains were resistant to two to eight drugs tested. The increase in resistance to Cmp is compared between two groups of strains. The subgroup of isolates from the outbreak was much more serious than that not related to the outbreak. The results show that there was no conjugative R plasmid among the strains not related to the outbreak, but epidemiological strains from an outbreak were positive in the same test. The significance should be determined by further study since only a few strains were tested.

9717/08309

Survey of Clinical, Epidemiological Characteristics of *Plesiomonas Shigelloides* Infection

40091037d Beijing ZHONGHUA LIUXINGBINGXUE ZAZHI [CHINESE JOURNAL OF EPIDEMIOLOGY] in Chinese Vol 8 No 6, Dec 87 pp 343-346

[English abstract of article by Xu Xinqiang [6079 2450 1730], et al., of the Hygiene and Anti-epidemic Station, Hangzhou]

[Text] From October 1984 to October 1985, the authors investigated *Plesiomonas shigelloides* infection in patients with gastroenteritis and food poisoning in the Hospital of Chinese Traditional Medicine in Hangzhou in order to further explore circumstances involving *Plesiomonas shigelloides* in diarrhea and food poisoning.

The authors examined stools from 864 patients with diarrhea and 12 patients with food poisoning, and found that 12 strains of *P. shigelloides* had a prevalence rate of 1.37 percent. In addition, they simultaneously isolated 16 strains of shigella, 8 strains of *Vibrio parahaemolyticus* and 2 strains of enteropathogenic *Escherichia coli*. Ten of the patients were from 15 to 49 years old, and 9 cases were male while 3 were female.

The clinical characteristics of the patients infected by *P. shigelloides* were similar to those infected by shigella, an illness characterized by diarrhea with watery or mucous stool and obvious abdominal cramps. A small percentage of patients experience fever, nausea, vomiting and malaise. The median duration of diarrhea is 3 to 4 days.

None of the patients presented severe dehydration. Most were treated with antimicrobial drugs and oral replacement of salt solution, recovering completely after 3 to 5 days.

Epidemiologic data suggested that five patients had ingested seafood and untreated water within 2 days before the attack, but other members of their families who had ingested the same food and water did not develop diarrhea.

This investigation proves that *P. shigelloides* infection existed among diarrhea patients in Hangzhou. More attention should be paid to this bacterium for further study chiefly involving the pathogenesis of the disease and its prevention.

9717/08309

Comparison of RPHI With McAbs, HI in Diagnosis of Japanese Encephalitis

40091037e Beijing ZHONGHUA LIUXINGBINGXUE ZAZHI [CHINESE JOURNAL OF EPIDEMIOLOGY] in Chinese Vol 8 No 6, Dec 87 pp 368-370

[English abstract of article by Zheng Xiwen [6774 6932 2429], et al., of the Institute of Epidemiology and Microbiology, Chinese Academy of Preventive Medicine, Beijing]

[Text] In this paper, a description is presented of a test of 124 paired (acute and recovered) sera from patients clinically diagnosed as having Japanese encephalitis by RPHI with McAbs and HI. Results show that the positive rates of RPHI and HI were 83.1 percent (103/124) and 79.0 percent (98/124), respectively, with $P < 0.05$. Few obvious differences existed between RPHI and HI. Further analysis of different levels of sera titer tested using two methods showed the positive correlation.

RPHI is easier and quicker than HI. As opposed to HI, it does not require the pretreatment of samples, and the results can be read within 30 to 60 minutes. Therefore, it is proven that RPHI is a more suitable method for diagnosing Japanese encephalitis.

9717/08309

Comparison of Different Micro-Blood Sampling Methods in Indirect Fluorescent Antibody Test for Malaria

40091037f Beijing ZHONGHUA LIUXINGBINGXUE ZAZHI [CHINESE JOURNAL OF EPIDEMIOLOGY] in Chinese Vol 8 No 6, Dec 87 pp 371-373

[English abstract of article by Huang Wenzhou [7806 2429 3166], et al., of the Institute of Parasitic Diseases, Chinese Academy of Preventive Medicine; WHO Collaborating Center for Malaria, Schistosomiasis, and Filariasis, Shanghai]

[Text] Two methods of micro-sample collection, capillary tube plasma and filter paper blood, were compared for their efficacy in determining the IFA (indirect fluorescent antibody) of malaria. Blood samples were collected from 56 infected macaque monkeys with Plasmo-

dium cynomolgi, 220 and 191 residents of two highly endemic areas, and were subjected to the IFAT. All of the antibody-positive rates and GMRT by the capillary method were significantly higher than those by the filter paper method. The results suggest that the capillary sampling method is more suitable for IFAT in the sero-epidemiological investigation of malaria in low endemic areas or in those areas where malaria is nearly eradicated.

9717/08309

Laser-Induced Cell Fusion Technique Successfully Tested

40081042g Beijing KEJI RIBAO [SCIENCE AND TECHNOLOGY DAILY] in Chinese 4 Dec 87 p 1

[Article by Ke Yan [2688 0917]: "Success in Feasibility Experiment With Laser-Induced Cell Fusion Technique. Trial Use of This New Technique by the Shandong Marine Academy Increases Spawn Survival Rate Following Cell Fusion"]

[Text] In 1987, the Shandong Marine Academy succeeded for the first time in an experiment with "laser-induced cell fusion technique." No reports have been seen in China on this new cell engineering technique.

Cell fusion techniques were developed in the 1960's. During the past more than 20 years, extensive results have been obtained from their use in the study of nucleoplasm correlation, soma cell heredity and development, the breeding of new strains, immunization, and

treatment of diseases. Furthermore, research in these fields has shown fine prospects; consequently, international academic circles have paid careful attention to it.

The physics, biology, and aquatic products departments of the Shandong Marine Academy worked together on this project. After completing a "study of the mutation-induced spectrum for farm crop and fish laser breeding methods," the task force began a feasibility experiment on laser-induced cell fusion. They selected the fertilized eggs of the loach as the specimen on which they used lasers with a wave length of 5,300 and 5,900 angstroms, irradiating 120 spawn pairs and obtaining 37 fused spawn. Cleavage and growth of the fused spawn was normal, each developing into fry, thereby demonstrating the feasibility of this fusion technique.

The greatest advantage of the Shandong Marine Academy's success with the laser-induced cell fusion technique is that it is "non-toxic" and non-injurious." It uses the single color, directional, and high intensity attributes of lasers to produce a peak power density of 100 megawatts per square meter. The extremely short nanoseconds operating time and the micron level micro-field operating microbundles accurately position radiation along a vertical direction on the photoplasmic membrane of the cell contact area awaiting fusion, cell fusion occurring without damage to other parts. This overcomes to a fairly large extent the problems encountered in not being able to deactivate safely the virulence of viruses and the toxicity of chemicals. It gets around the problem of electrical fusion methods in which high voltage pulses penetrate the entire cell causing electrical damage, enabling an increase in the spawn survival rate following fusion.

9432

Rare-Earth Magnet Products Find Ready World Market

40080054c Beijing KEJI RIBAO in Chinese
1 Dec 87 p 1

[Summary] With an eye to the international market, China has been promoting research and development in the field of neodymium/iron/boron (NdFeB) superstrong permanent magnet materials. In terms of production technology, product quality, and performance, China has already entered the world's front ranks. With the China Academy of Sciences' San Huan [0005 3883] New Materials R&D Company at the head, a new type of high-technology industry—development and application of rare-earth magnets—is now being formed.

Since relatively abundant Fe and Nd have replaced expensive cobalt and scarce samarium, and since electric machines produced with these materials are smaller, lighter, less expensive, and higher in performance, the U.S., Japan, and Western Europe have in recent years invested enormous assets in NdFeB R&D. According to market research, annual world output up to 1995 of permanent magnet materials may exceed 6000 tons.

In light of this revolution, the Chinese Academy of Sciences, the Ministry of Metallurgical Industry's Iron and Steel Research Institute, and other governmental units, taking the lead in promoting major development to catch up with the U.S. and Japan and to overtake Western Europe, have established NdFeB production lines at Ningbo, Shanghai, Changshu, Baotou, Jilin, Zhaoqing, and other places. The national output for 1987 was approximately 100 tons with an output value of more than 20 million yuan) with approximately 50 percent of the products entering the world market. With current construction of several production lines that can handle over 30 tons annually, it is estimated that within 2 years, gross output value of China's NdFeB production could surpass 100 million yuan.

/12223

Ten Major Events of 1987 in Chinese Computer World

40080054a Beijing JISUANJI SHIJIE in Chinese
6 Jan 88 p 1

[Summary] Ten major events for 1987 were:

(1) Establishment of the laterally tied Changjiang [7022 3068], Changbai [7022 4101], Langchao [3186 3390], Taiji [1132 2817], and Zhonghuan [0022 3883] Computer companies in important industrial areas.

(2) Establishment of a committee [under the Ministry of Electronics Industry and the Law Bureau of the State Council [to draft "Software Protection Regulations," and formation of a "National Software Registration Center."

(3) Governmental adoption of a policy of preferential treatment toward production of computers, software, ICs, and program-controlled switchboards, and the Ministry of Finance's naming of the first group of reduced-tax or remitted-tax enterprises.

(4) Organization by the [State Council's] Leading Group for Development of Electronics Industry of the first national microcomputer testing and appraisal board, which has judged 19 models as outstanding.

(5) Production and marketing of new-generation microcomputers: the 286 (0530) series and the 386 model.

(6) Establishment at Beijing, Shanghai, Nanjing, Wuhan, and other cities of national-level high-technology laboratories in fields such as software and artificial intelligence.

(7) Development of the first unified standards examination for applications software personnel, carried out jointly in 19 provinces and cities.

(8) Beginning purchases of Chinese computer technology or products by several major international computer companies. IBM has chosen China Southwest Electronics (at Shekou [in Guangdong]) Company's computer power source; DEC has purchased the "5-stroke-character Chinese coding scheme" patent, and Fujitsu has been using system software developed by Qinghua University. The Kaifa Keji ["Develop Science & Technology"] Company (at Shekou) has become the world's sixth largest factory in production of magnetic heads.

(9) Completion at the National Economic Information Center of China's first large-scale-computer "Macroeconomic Integrated Database System."

(10) Uncovering at Dalian and Shenzhen of [China's first] major cases of computer crime.

/12223

China's Information Industry Develops Rapidly in 1987, But Enormous Gaps Still Exist

40080054b Beijing JISUANJI SHIJIE in Chinese
6 Jan 88 p 1

[Summary] From three recent national conferences, the following information has been learned: while there has been soaring growth in the electronics and computer industries yet again in 1987, rigorous trials are ahead. Domestic output in 1987 of large-scale, medium-scale, and minicomputers reached 396, and output of microcomputers was 59,000, increases of 41% and 51%, respectively, over 1986. Stress has simultaneously been placed on the absorption of [imported] critical advanced technologies such as 5-micron ICs; imports of all ICs broke the 78,000,000 barrier, a 70% increase over 1986. The campaign for domestic production has also seen new

advances. The percentage of [Chinese-made] 16-bit-and-under microcomputers on the domestic market has surpassed 60%. The Taiji [1132 2817] 2220 minicomputer, except for a portion of its key parts, is entirely self-produced, realizing a system-wide savings of 67% on [foreign] exchange. Several products such as the Great Wall 0520 microcomputer have begun to enter the international market.

On the other hand, the computer industry's soaring growth also carries with it a stern challenge to combat. The output value of the electronics industry (approximately 40 billion yuan) comprised only 3% of the nation's gross industrial output value. The output value of investment-type electronic products formed only 23.6% of the electronics industry's output value, and computers and other equipment made up only a very small part of investment-type electronic products. The computer industry has now become global, with unusually rapid development and intense competition, and China—in terms of technological level, production efficiency, economic returns, and export trade—still lags far behind developed areas, even behind the "Four Small Dragons."

The competitiveness of China's computer products on the international market is just emerging, the technological base of all industries is still comparatively weak, internal structural adjustments still cannot keep pace with developing circumstances, and the management mechanism and corresponding developmental policy still have not fully brought their forces into play.

In answer to this challenge, delegates at the conferences have raised the strategic goals of strengthening self-development; expanding supply capabilities; continually increasing the percentage of important products that are domestically made, their domestic market share, and their export; building a minicomputer, microcomputer, software, and peripherals industry on the basis of fourth-generation computer technology; actively developing large-and-medium-scale computer technology; and realizing merchandization and standardization of software.

/12223

Zhejiang University Completes High-Purity Silicon, Silane Lab

40080045a Beijing RENMIN RIBAO in Chinese
18 Nov 87 p 4

[Article by correspondent Lu An [0712 1489] of Xinhua, Hangzhou 16 Nov: "Zhejiang University Completes High-Purity Silicon and Silane Lab"]

[Text] One of the research and development bases for silicon semiconductors—The National High-Purity Silicon and Silane Laboratory—has been built at Zhejiang University. It passed inspection by the State Education Commission on 15 November.

This lab occupies 5000 square meters of area. It has a semiconductor pilot plant and a technical staff of nearly 100.

The expert committee in charge of the inspection believes that the completion of this lab will have an important effect on improving the quality of silicon materials and devices in China, as well as on training high-caliber research people.

High-purity silicon and silane are essential materials in electronics. They are used in solar-energy conversion, novel optical-guide materials, high-temperature ceramics, new lasers and nuclear radiation detection.

The construction of this lab began in July 1985. During the course, the researchers insisted on combining teaching, research and production. Eight major research accomplishments have been obtained to date. They were recognized with national invention awards and technical progress awards from the State Education Commission and Zhejiang Province and were put into production.

According to a reliable source, more than 80 percent of the entire nation's supply of single-crystal silicon high-resistance detectors and high-purity silane gas is annually produced by the lab.

12553/12232

Key State Surface-Physics Lab Operational

40080045b Beijing RENMIN RIBAO in Chinese
22 Nov 87 p 1

[Article by Meng Yangjie [1322 2876 2638] of Xinhua, Beijing 21 Nov: "Key State Surface-Physics Lab Operational"]

[Text] A key state surface-physics lab constructed jointly by the Institute of Physics and the Institute of Semiconductors of the Chinese Academy of Sciences passed government inspection and is officially open for use.

Surface physics is a cutting-edge area in physics. The objective is to prepare various superior surfaces and contacts of metals, semiconductors, and insulators through experimental means. Surface-physics studies can improve present integrated circuit technology and raise the specifications of various materials.

This key state surface-physics lab is equipped with modern experimental equipment for the preparation of surfaces and contacts between dissimilar materials, for various analytical techniques and for theoretical research. It includes a high quality molecular beam epitaxy machine and an electron-diffraction device for surface analysis. In mid May 87, scientists successfully developed a world-class superconducting oxide film operating in the liquid nitrogen temperature range.

Wang Dingsheng [3769 7307 4141], director of the lab, pointed out that the lab was financed by the government. It is a modern research institute with an open structure. The work will be directed by a technical committee consisting of 15 experts from 10 organizations. At present, there are 16 organizations submitting 45 applications to request that the lab conduct scientific studies.

12553/12232

15

This is a U.S. Government publication. Its contents in no way represent the policies, views, or attitudes of the U.S. Government. Users of this publication may cite FBIS or JPRS provided they do so in a manner clearly identifying them as the secondary source.

Foreign Broadcast Information Service (FBIS) and Joint Publications Research Service (JPRS) publications contain political, economic, military, and sociological news, commentary, and other information, as well as scientific and technical data and reports. All information has been obtained from foreign radio and television broadcasts, news agency transmissions, newspapers, books, and periodicals. Items generally are processed from the first or best available source; it should not be inferred that they have been disseminated only in the medium, in the language, or to the area indicated. Items from foreign language sources are translated. Those from English-language sources are transcribed, with the original phrasing and other characteristics retained.

Headlines, editorial reports, and material enclosed in brackets [] are supplied by FBIS/JPRS. Processing indicators such as [Text] or [Excerpts] in the first line of each item indicate how the information was processed from the original. Unfamiliar names which are rendered phonetically or transliterated by FBIS/JPRS are enclosed in parentheses. Words or names preceded by a question mark and enclosed in parentheses were not clear from the original source but have been supplied as appropriate to the context. Other unattributed parenthetical notes within the body of an item originate with the source. Times within items are as given by the source.

SUBSCRIPTION/PROCUREMENT INFORMATION

The FBIS DAILY REPORT contains current news and information and is published Monday through Friday in 8 volumes: China, East Europe, Soviet Union, East Asia, Near East & South Asia, Africa (Sub-Sahara), Latin America, and West Europe. Supplements to the DAILY REPORTs may also be available periodically and will be distributed to regular DAILY REPORT subscribers. JPRS publications generally contain less time-sensitive information and are published periodically. Current JPRS publications are listed in *Government Reports Announcements* issued semi-monthly by the National Technical Information Service (NTIS), 5285 Port Royal Road, Springfield, Virginia 22161 and the *Monthly Catalog of U.S. Government Publications* issued by the Superintendent of Documents, U.S. Government Printing Office, Washington, D.C. 20402.

U.S. Government offices may obtain subscriptions to the DAILY REPORTs or JPRS publications (hardcovers or microfiche) at no charge through their sponsoring organizations. DOD consumers are required to submit requests through appropriate

command validation channels to DIA, RTS-2C, Washington, D.C. 20301. (Telephone: (202) 373-3771, Autovon: 243-3771.) For additional information or assistance, call FBIS, (703) 527-2368, or write to P.O. Box 2604, Washington, D.C. 20013.

The public may subscribe to either hardcover or microfiche versions of the DAILY REPORTs and JPRS publications through NTIS at the above address or by calling (703) 487-4630. Subscription rates will be provided by NTIS upon request. Subscriptions are available outside the United States from NTIS or appointed foreign dealers. Back issues or single copies of the DAILY REPORTs and JPRS publications are not available. New subscribers should expect a 30-day delay in receipt of the first issue.

Both the DAILY REPORTs and the JPRS publications are on file for public reference at the Library of Congress and at many Federal Depository Libraries. Reference copies may also be seen at many public and university libraries throughout the United States.