

LOAN DOCUMENT

PHOTOGRAPH THIS SHEET

DTIC ACCESSION NUMBER

LEVEL

INVENTORY

DOCUMENT IDENTIFICATION

DISTRIBUTION STATEMENT

ACCESSION FOR	
NTIS	GRAM <input checked="" type="checkbox"/>
DTIC	TRAC <input type="checkbox"/>
UNANNOUNCED <input type="checkbox"/>	
JUSTIFICATION	
BY	
DISTRIBUTION/	
AVAILABILITY CODES	
DISTRIBUTION	AVAILABILITY AND/OR SPECIAL
A-1	

DISTRIBUTION STAMP

Reproduced From
Best Available Copy

19981223 080

DATE RECEIVED IN DTIC

DATE ACCESSIONED

DATE RETURNED

REGISTERED OR CERTIFIED NUMBER

HANDLE WITH CARE

PHOTOGRAPH THIS SHEET AND RETURN TO DTIC-FDAC

UNCLASSIFIED

NO DISTRIBUTION
STATEMENT

NADC
Tech. Info.

APPENDIX 27
SS NEW EMITTER START UNIT (NESU) & FLOW CHARTS
FINAL SOFTWARE REPORT
DATA ITEM NO. A005

Reproduced From
Best Available Copy

INTEGRATED ELECTRONIC WARFARE SYSTEM ADVANCED DEVELOPMENT MODEL (ADM)

7800987-27

PREPARED FOR:
NAVAL AIR DEVELOPMENT CENTER
WARMINSTER, PENNSYLVANIA
CONTRACT N62269-75-C-0070



ELECTROMAGNETIC
SYSTEMS DIVISION

1 OCTOBER 1977

UNCLASSIFIED

APPENDIX 27
SIGNAL SORTER NEW EMITTER SOFTWARE DESIGN SPECIFICATION
FINAL SOFTWARE REPORT
DATA ITEM A005

INTEGRATED ELECTRONIC WARFARE SYSTEM (IEWS)
ADVANCED DEVELOPMENT MODEL (ADM)

Contract No. N62269-75-C-0070

Prepared for:

Naval Air Development Center
Warminster, Pennsylvania

Prepared by:

RAYTHEON COMPANY
Electromagnetic Systems Division
6380 Hollister Avenue
Goleta, California 93017

1 OCTOBER 1977

COMPUTER PROGRAM DESIGN SPECIFICATION

IEWS Signal Sorter NESU Software

1.0 SCOPE

This document describes the operation of the New Emitter Start Unit (NESU) software/which performs the new emitter detection function in the IEWS Signal Sorter.

2.0 APPLICABLE DOCUMENTS

WS-8506 Requirements for Digital Computer Program Documentation, Rev. 1, dated 1 November 1971

RP-16 Micro-Processor Manual

5412-IEWS:75:04 New Emitter Search Unit Design Specification, Rev. B

3.0 REQUIREMENTS

3.1 FUNCTION ALLOCATION/DESCRIPTION

The NESU software consists of the following modules:

Initializer

NESU Main Program

Core Manager

PDW Buffer Interrupt Handler

Bus Hung Interrupt Handler

The Initializer initializes the NESU buffers, flags and tables, the PDW Buffer, and the NESU CAM. The NESU Main Program performs the processing of PDW's detection of new emitters, communication with the Supervisor, and control of the NESU CAM. The Core Manager maintains dynamic core storage used for storing PDW's. The PDW Buffer Interrupt Handler processes all PDW Buffer full interrupts, and the Bus Hang Interrupt Handler processes all Bus Hang interrupts.

3.2 FUNCTIONAL DESCRIPTION

3.2.1 INITIALIZATION MODULE

The Initialization Module initializes all of the software in the NESU. This module is executed when the Supervisor performs an Initialize and New Start of the NESU Micro-Processor or the NESU received an Initialize message from the Supervisor. The Initialization Module clears the NESU CAM, the Emitter File, the PDW Buffer, the AOA File, initializes the PDW Buffer control, sets the Idle flag, enables all interrupts, and starts the NESU Main Program.

3.2.2 NESU MAIN PROGRAM

The NESU Main Program processes all incoming Supervisor messages, inputs and processes PDW's in the PDW Buffer, searches the CAM and links PDW's to the best matching track file, maintains the AOA File, generates new track files and maintains the NESU CAM.

The Supervisor messages and the actions taken for each message are:

Stop NESU Function	Set Idle Flag
Initialize and Restart	Start Initialization Module
Modify Track Start Threshold	Set Track Start Threshold to new value
AOA Threshold Modify	Set AOA Threshold to new value
AOA Readout Request	Send AOA File Dump messages to Supervisor
CAM File Dump	Send CAM File Dump messages to Supervisor
Continue NESU	Clear Idle flag

The Supervisor message input buffer consists of two words where the first word is a flag and the second word is used to store a value. The contents of the flag word have the following meanings:

0	Buffer Empty
1	Stop NESU Message
2	Initialize and Restart Message
3	Modify Track Start Threshold - second word contains threshold
4	AOA Threshold Modify - second word contains threshold
5	AOA Readout Request
6	CAM File Dump
7	Continue NESU

The flag word is set by the Supervisor to the proper value and is cleared by the NESU when the message is processed.

The NESU contains three output message buffers. Two are used for sending high priority messages to the Supervisor and one is used for sending low priority messages to the Supervisor. The two high priority message buffers contain two words apiece where the first word is a flag word. The NESU sets the flag word to a 1 for a New Emitter Message and a 2 for a Supervisor PDW Message. The format for a New Emitter Message is:

Word 0	1
Word 1	Pointer to PDW List
Word 2 - 9	Standard Track File Format

Word 1 contains the address of the first PDW block in the list of 10 PDW's used to generate the New Emitter Parameters. Each block consists of 5 words where the first word contains the address of the next block and the second through fifth words contains the PDW data in standard PDW format. The first word in the last block of the list contains a zero.

The Supervisor PDW Message has the following format:

Word 0	2
Word 1	File Number
Word 2	Pointer to PDW Block

Word 2 contains the address of a 5 word PDW block which contains the PDW data in the last four words in standard PDW format. The Supervisor is expected to clear the flag word in a high priority message buffer to zero when it is through processing a message indicating to the NESU that the buffer is available for another message.

The low priority output message buffer consists of 6 words and is used for sending CAM File Dump messages and AOA File Dump messages. The first word is a flag word whose contents have the following meaning:

0	Buffer Empty
1	CAM File Dump message
2	AOA File Dump message

The CAM File Dump message has the following format:

Word 0	1
Word 1	File Number
Word 2	Valid Field Contents
Word 3	Count Field Contents
Word 4	Azimuth Field Contents
Word 5	Frequency Field Contents

The AOA File Dump Message has the following format:

Word 0	2
Word 1	Cell Number
Word 2	Count

The Supervisor must clear the flag word to zero when it is through processing the message indicating that the buffer is available for another message.

The PDW Input Buffer consists of a 4K RAM which is divided into two 2K sub-buffers. The Track Correlator places PDW's into the buffer as a five word entries. The format of the entry is:

Word 0	bit 15	Always one
	bit 8	Unassociated PDW Flag
	bit 7 - 0	TDM File Number
Word 1 - 4	Standard PDW Format	

When the NESU begins processing a sub-buffer, it commands the TC to switch to the other buffer. Each PDW is copied into a core block obtained from the Core Manager and the first word of the entry is set to zero. The PDW is then processed and the next entry examined. If an entry is found with its first word all zeros, the NESU commands the TC to swap buffers and it starts searching the sub-buffer that was being filled by the TC for incoming PDW's. All PDW entries with bit 8 of the first word reset are assumed to be Supervisor PDW's and the NESU sends a Supervisor PDW message and generates a New Emitter Alert interrupt to the Supervisor. All other PDW entries are used to attempt to generate New Emitter Parameters.

The Purge flag is set by the Supervisor every 250 ms. The NESU Main Program checks the flag periodically at a rate depending on the number of messages and PDW's arriving. When the NESU Main Program finds the Purge Flag set, it clears the flag and searches the Emitter File for all entries which have their Purge bit set and a count equal to one. For each entry found, the valid bit in the CAM is cleared, and any PDW blocks linked to the entry are returned to free core storage. The AOA File entry for the particular azimuth cell is decremented for each PDW returned. The Main Program then searches the Emitter File for all entries which have their Purge bit set with a count greater than one. For all entries found the count is decremented by one and the oldest PDW block returned to free core storage. An AOA File Entry is decremented for each PDW returned corresponding to the PDW azimuth cell. The Purge bit is then set on all remaining entries in the Emitter File.

3.2.3 CORE MANAGER

The Core Manager consists of two subroutines: The Get Block subroutine and the Return Block subroutine. Dynamic memory storage is

arranged into blocks of five words apiece and linked into a single queue of available core blocks. This queue is shared by the Supervisor and the NESU in a common 4K 2-port RAM which also contains the SOQ and EOQ pointers. The queue is initially linked by the Supervisor initializer module and maintained by both the Supervisor and NESU Core Managers. A core block is obtained by issuing the following call:

JSUB (G=TBL)

The Get Block routine removes a block from the queue and returns to the calling routine with the address of the block in the X-register. One or more blocks are returned by issuing the following call:

JSUB (=RTBL)

The X-register must contain the address of the first block and the B-register must contain the address of the last block. The first word of each block must contain the address of the next successive block with the first word of the last block containing zero. If only one block is being returned, the first word of the block must contain zero and both the X register and the B-register must contain the address of the block.

3.2.4 PDW BUFFER INTERRUPT HANDLER

The PDW Buffer Interrupt Handler processes all PDW Input Buffer interrupts. An interrupt is received from the Track Correlator whenever it reaches the end of a sub-buffer indicating that it has filled a sub-buffer before the NESU has finished processing the previous buffer. The PDW Buffer Interrupt Handler sets the PDW Buffer Full flag upon an interrupt and performs an interrupt return.

3.2.5 BUS HUNG INTERRUPT HANDLER

The Bus Hung Interrupt Handler processes all Bus Hung Interrupts. When an interrupt is received, the interrupt handler sends an error message to the Supervisor, saves all registers and halts.

3.2.6 EMITTER FILE

The Emitter File contains 32 8-word entries; one for each track file in the NESU CAM. The format of each entry is:

Word 0	Flags
Word 1	PDW SOQ Pointer
Word 2	PDW EOQ Pointer
Word 3	PDW Count
Word 4	Azimuth
Word 5	Frequency
Word 6-7	Time of Arrival of last PDW

flag bits (if set):

15	Valid
14	New Emitter File
13	Purge

The valid bit indicates that the file is active. The New Emitter File bit indicates that a New Emitter File has been generated and sent to the Supervisor, and that all PDW's that match the file are to be dropped. The purge bit is used for purging entries as described in paragraph 3.2.2. Words 1 and 2 point to a list of PDW blocks currently linked to the entry. The first word in each block contains the address of the next successive block. The last block contains a zero in its first word. Word 3 contains the count of blocks which have been linked. Word 4 contains the azimuth value written into the CAM and Word 5 contains the frequency value written into the CAM. Words 6 and 7 contain the TOA of the last linked PDW.

3.2.7 AOA FILE

The AOA File consists of 64 1-word entries, one for each angle cell. For each PDW linked to an Emitter File entry, the AOA File entry corresponding to the azimuth is incremented. This file is used by the NESU Main Program for detecting agile emitters.

3.3 STORAGE AND PROCESSING ALLOCATION

The following table summarizes the storage and processing time for the NESU Software:

Initialization Module	200 words	1.0 ms.
Main Program	800 words	4.0 ms.
Get Block Subroutine	20 words	60 micro-seconds.
Return Block Subroutine	30 words	90 micro-seconds.
PDW Buffer Interrupt Handler	20 words	60 micro-seconds.
Bus Hung Interrupt Handler	20 words	60 micro-seconds.
Emitter File	256 words	N/A
AOA File	64 words	N/A
Free Core Storage	1600 words	N/A
PDW Input Buffer	4096 words	N/A
TOTAL	7106 words	

The processing time of the NESU Main Program varies depending on the steps being performed. The processing time for various actions are:

Supervisor message	50 micro-seconds to 2 ms.
Supervisor PDW	150 micro-seconds
Link PDW to Emitter Entry	300 micro-seconds
Generate New Emitter	4.0 ms.
Discard PDW	240 micro-seconds

The processing load per second of the steady-state condition of 570 Supervisor PDW's, 1000 unassociated PDW's, and 5 new emitters being generated is

Supervisor PDW	85.5 ms.
Link PDW to Emitter Table	15.0 ms.
Generate New Emitter	20.0 ms.
Discard PDW	133.0 ms.
TOTAL	253.5 ms./second

3.4 FUNCTIONAL FLOW DIAGRAM

Figure 3.1 shows the overall operation of the NESU Main Program. Figure 3.2 shows the New Track Generation Procedure.

3.4.1 PROGRAM INTERRUPTS

The hardware interrupts received by the NESU in order of priority are:

Bus Hung Interrupt

PDW Input Buffer Interrupt

The Bus Hung Interrupt indicates a software malfunction in which non-existent device or memory location was referenced. This is considered a non-recoverable error requiring reloading of the NESU Software. The PDW Input Buffer interrupt is generated when the TC fills a sub-buffer with PDW's. This normally happens when the NESU is unable to keep up with the incoming PDW rate. The size of the sub-buffers is set such that there are enough PDW's in the sub-buffer to allow the NESU to generate 30 new tracks in a cold start situation.

3.5 PROGRAMMING GUIDELINES

The NESU software is coded in RP-16 Assembly Language and assembled with the RP-16 Relocatable Assembler (RAMA). The software is loaded into the NESU RAM by the System Controller which loads a loading routine into the 1K RAM common to the Supervisor Micro-Processor, performs an Initialize and New Start Sequence, and sends the object text to the loading routine.

3.6 QUALITY ASSURANCE

TBD

FLOW CHART

REMARKS

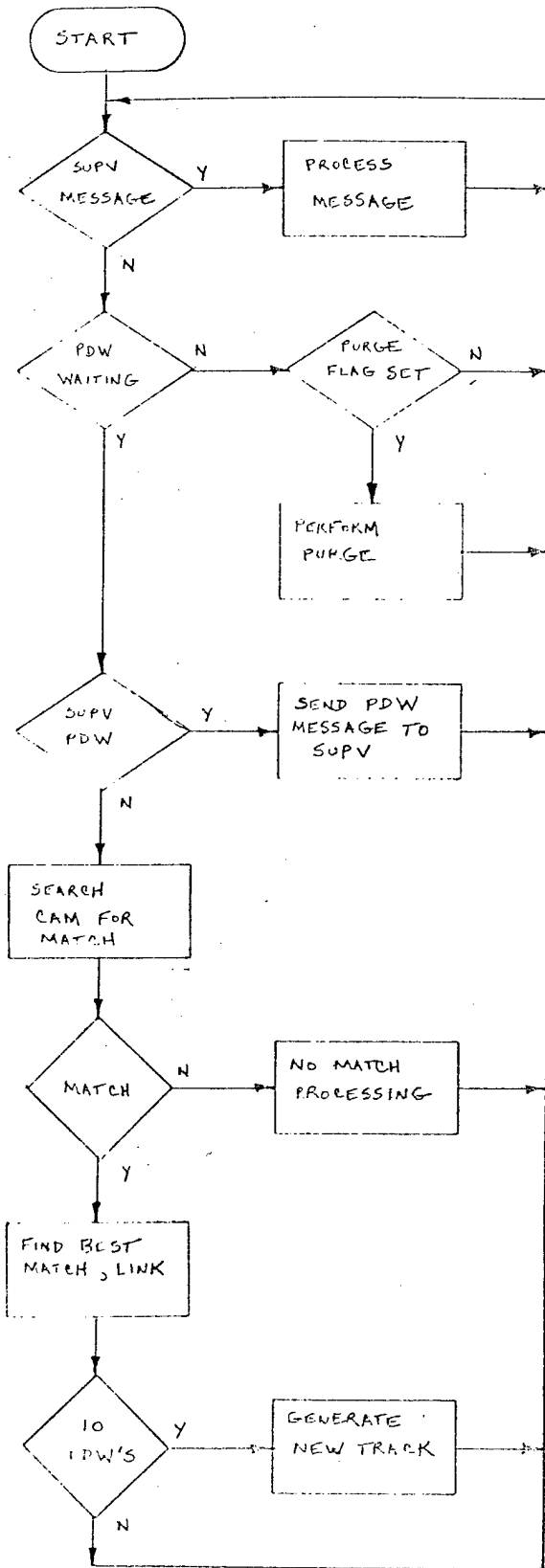

FIGURE 3.1

RAYTHEON		RAYTHEON COMPANY LEXINGTON, MASS 02173	
PROGRAM PRODUCTIVE ENERGY RESEARCH			
NESO MAIN PROGRAM			
49956	PREPARED BY	DATE	
SHEET 1 OF 1			

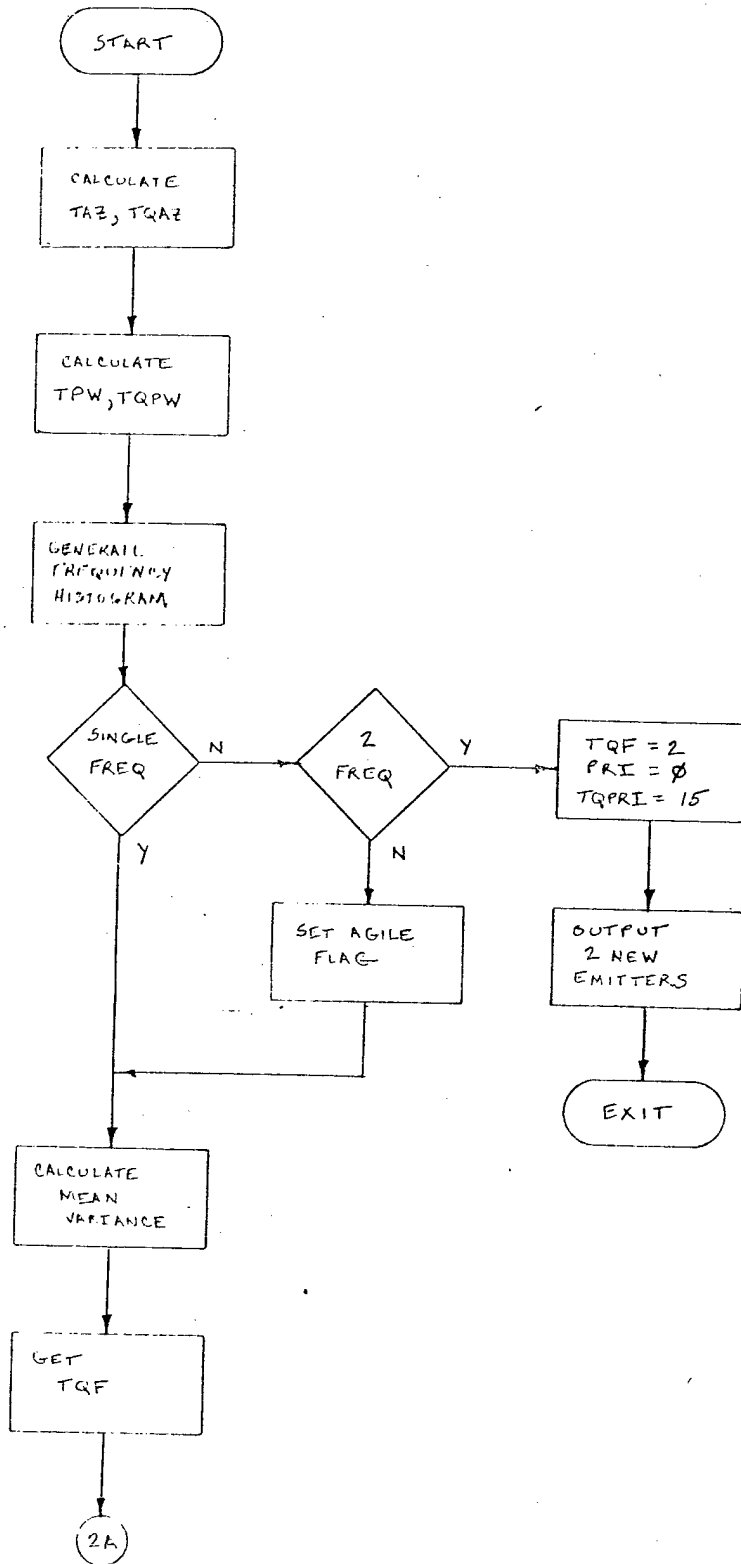

FIGURE 3.2

RAYTHEON		RAYTHEON COMPANY LEXINGTON, MASS 02173	
PROGRAM / ROUTINE / SUBROUTINE / ACRONYM GENERATE TRACK			
FORM NO 49956	PREPARED BY	DATE	
SHEET 1 OF 2			

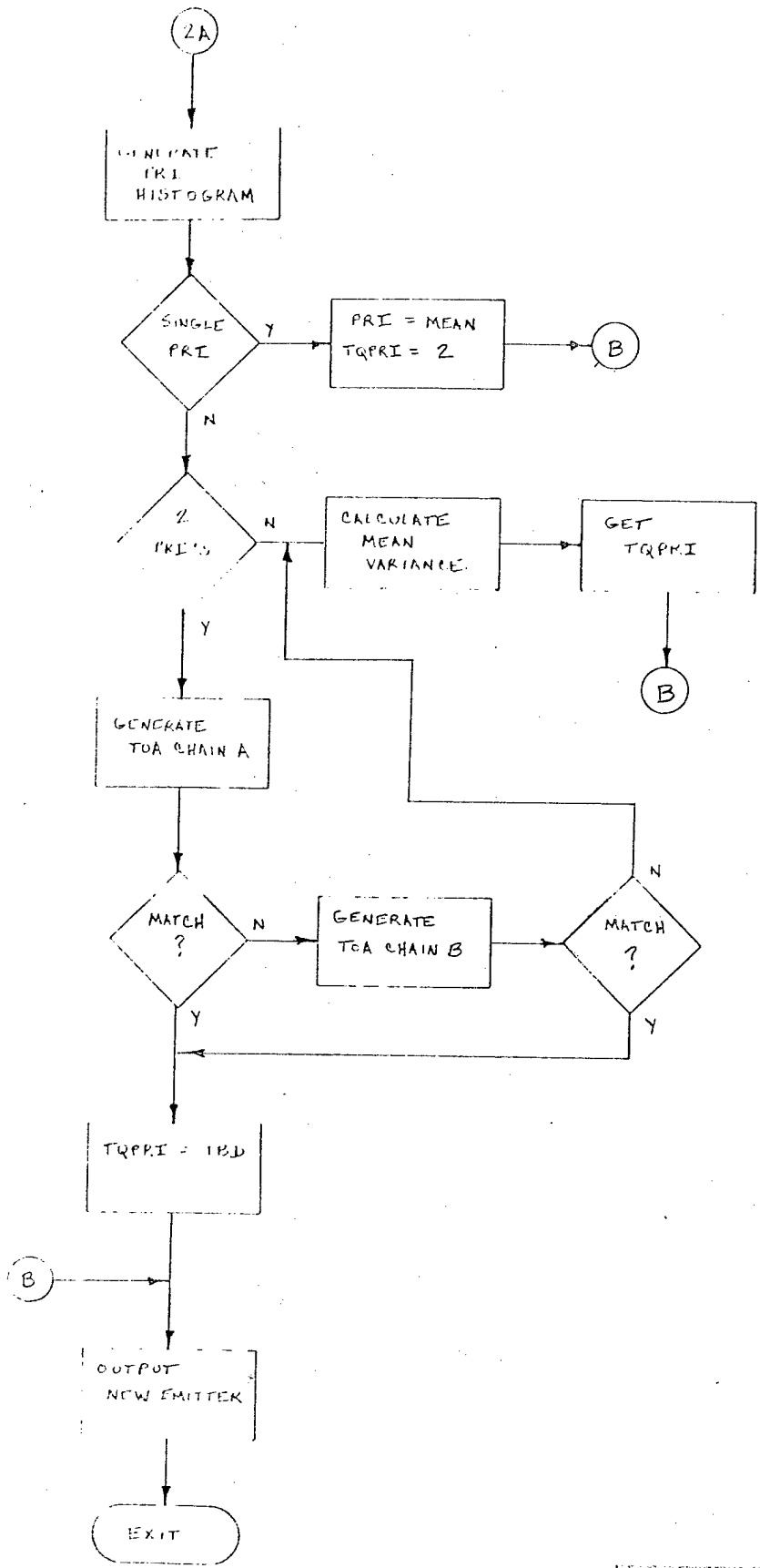
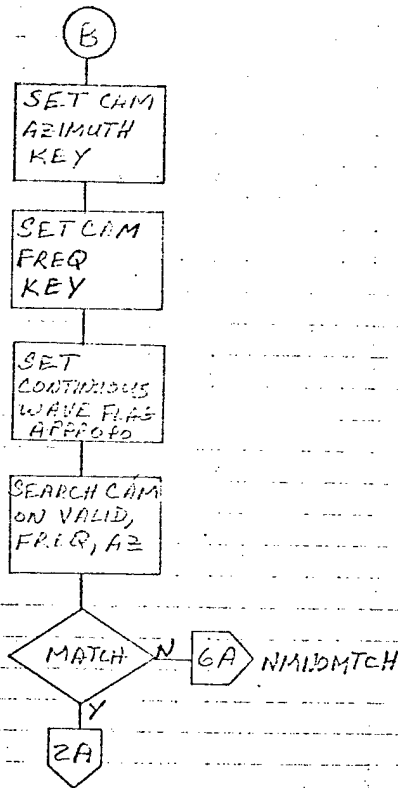
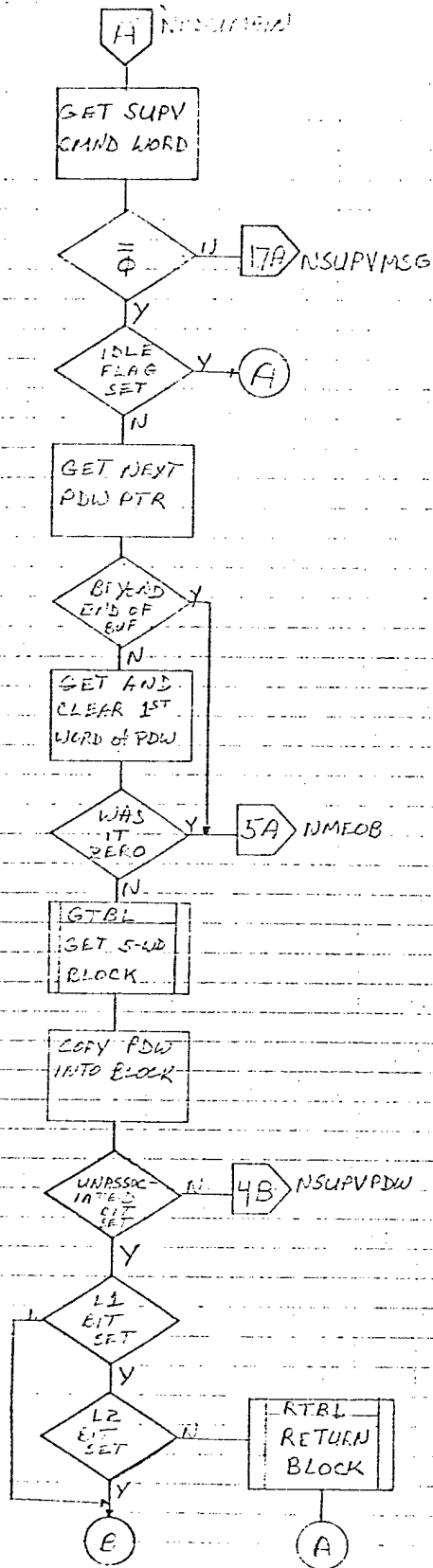

FIGURE 3.2 (CONT.)

RAYTHEON		RAYTHEON COMPANY LEXINGTON, MASS 02173	
PROGRAM ROUTINE SUBROUTINE FACILITY			
GENERATE TRACK			
FORM IDENT NO 49956	PREPARED BY	DATE	
NUMBER	SHEET 2 OF 2		



NESUMAIN IS THE ROOT OF THE NESU TREE

SUPERVISOR REQUESTS TAKE PRIORITY OVER PDW PROCESSING

MATCH RETURNS INDEX TO START OF CORRESPONDING EMFL TABLE ENTRY

ONLY THE LAST PDW DESCRIBING A LONG PULSE IS USED

NOTE: 17B DENOTES SHEET 7 LABEL B

RAYTHEON		RAYTHEON COMPANY LEXINGTON, MASS 02173	
<small>PROPERTY OF THE GOVERNMENT - NOT TO BE REPRODUCED WITHOUT AUTHORITY</small>			
1EUS-SUPTR - NESU (DETAIL)			
49956	C.G. JENNINGS	DATE	DATE
NAMES	NAME	SHEET 1 OF 19	

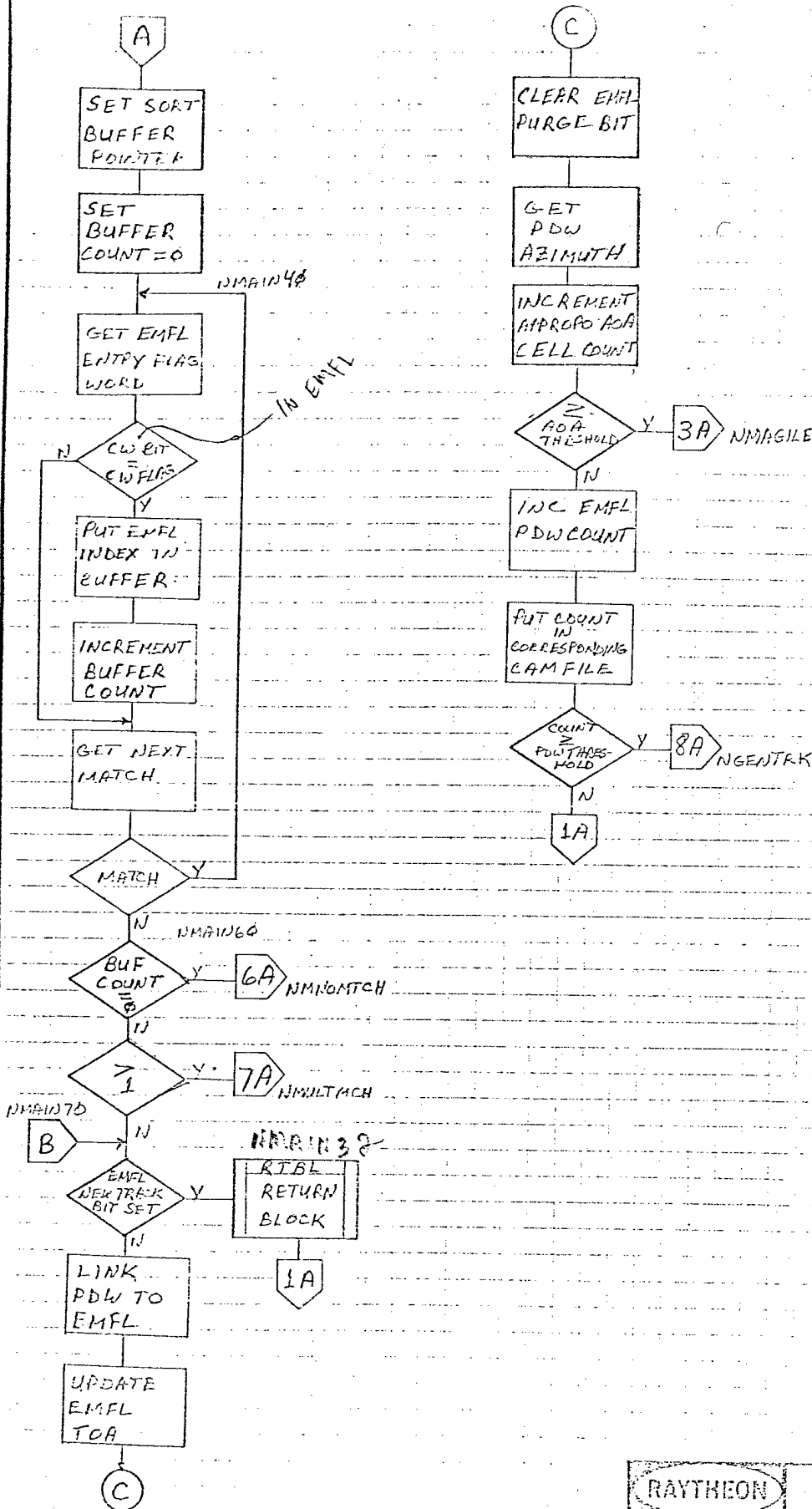

FREQUENCY AGILE EMITTER CHECK

A PDW MATCH MUST INCLUDE AZIMUTH, FREQUENCY AND CONTINUOUS WAVE

TRTH - NUMBER OF PDWS REQUIRED TO GENERATE NEW TRACK

IGNORE PDW MATCHING-FILE RECENTLY SENT TO SUPERVISOR

EMFL TOA AND PURGE BIT ARE USED TO PURGE NOISE AND "OLD" ENTRIES

RAYTHEON		RAYTHEON COMPANY LEXINGTON, MASS 02173	
PROGRAM ROUTINE SUBROUTINE ACCTNAM			
LEWIS SCOTTER - NESU			
49956		DATE	
NUMBER MAIN		SHEET 2 OF 19	

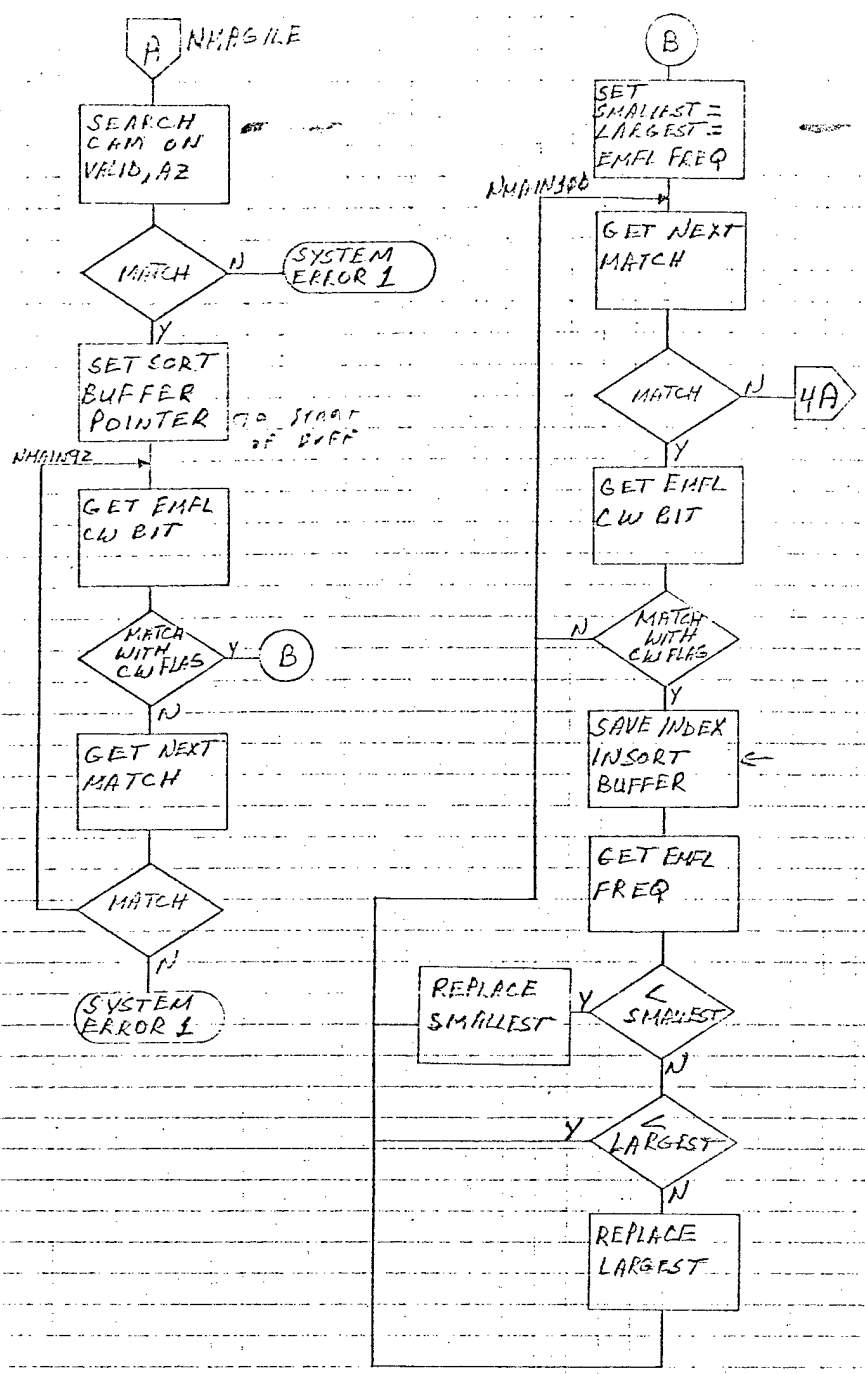

RAYTHEON		RAYTHEON COMPANY LEXINGTON, MASS. 02173	
<small>PROGRAM ROUTINE THROUGHOUT OF ACADAM</small>			
NEWS EDITOR - NESU			
FORM NO.	REVISION	DATE	
49956			
NUMBER	FILE NAME	SHEET	OF
		3	17

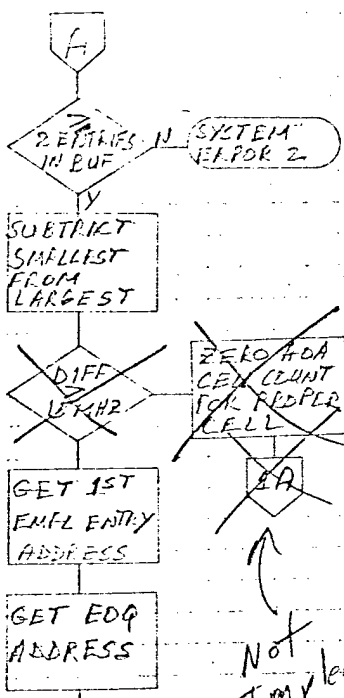

Not Implemented

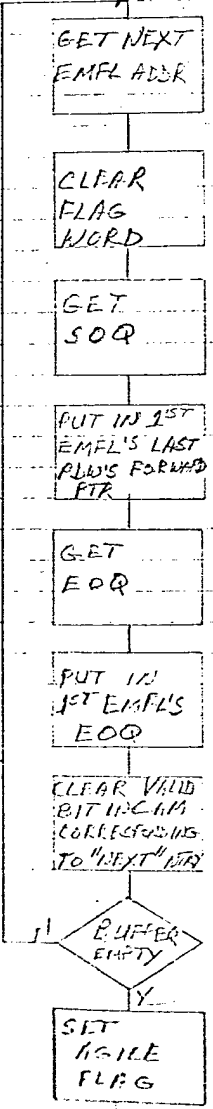
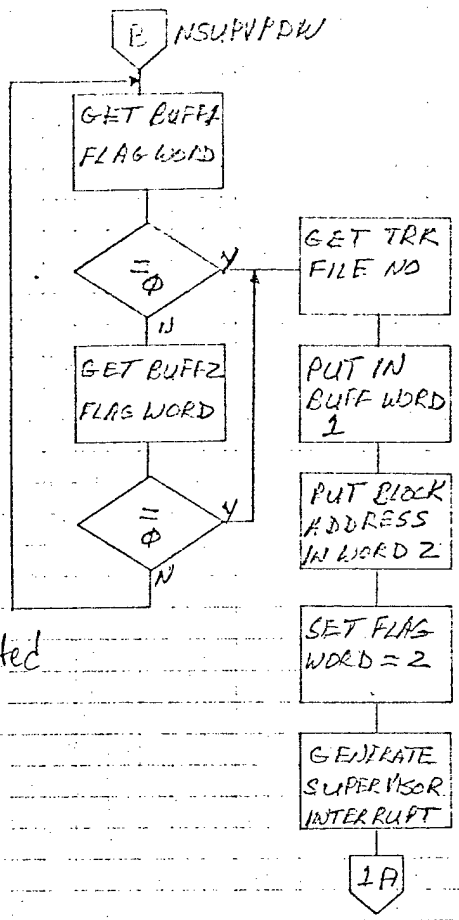

MAIN 149

EA
NEXT

RAYTHEON		RAYTHEON COMPANY LEXINGTON, MASS. 02173	
ITEMS SORTER - NESU			
49956	REPLACES	DATE	
NUMBER COPY FROM		SHEET 4 OF 19	

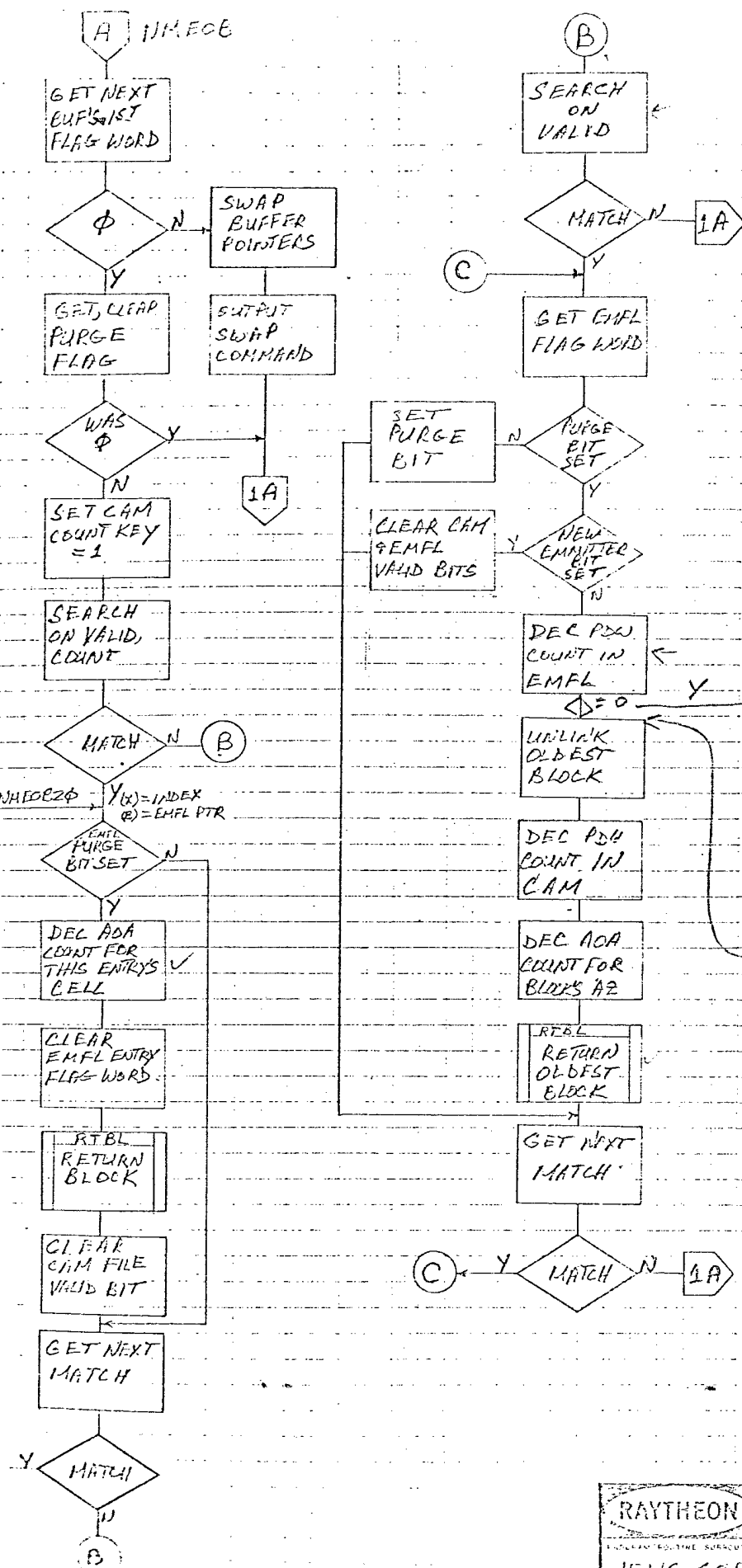

WHEN THE NESU GETS AHEAD OF PDW INPUT AND THE SUPV HAS SET THE NESU PURGE FLAG, EMFL ENTRIES WHO HAVE NOT RECEIVED A PDW SINCE THE LAST PURGE CYCLE ARE RELIEVED OF THEIR OLDEST PDW. OTHER VALID ENTRIES ARE MARKED FOR THE NEXT CYCLE.

RAYTHEON		RAYTHEON COMPANY	
		LEXINGTON, MASS. 02173	
<small>FOR CLEAN ROOM THE SUBSEQUENT APP. NUM</small> JENS SOPTER - NESU			
49956	PREPARED BY	DATE	
NUMBER 11466B	SHEET 5		OF 19

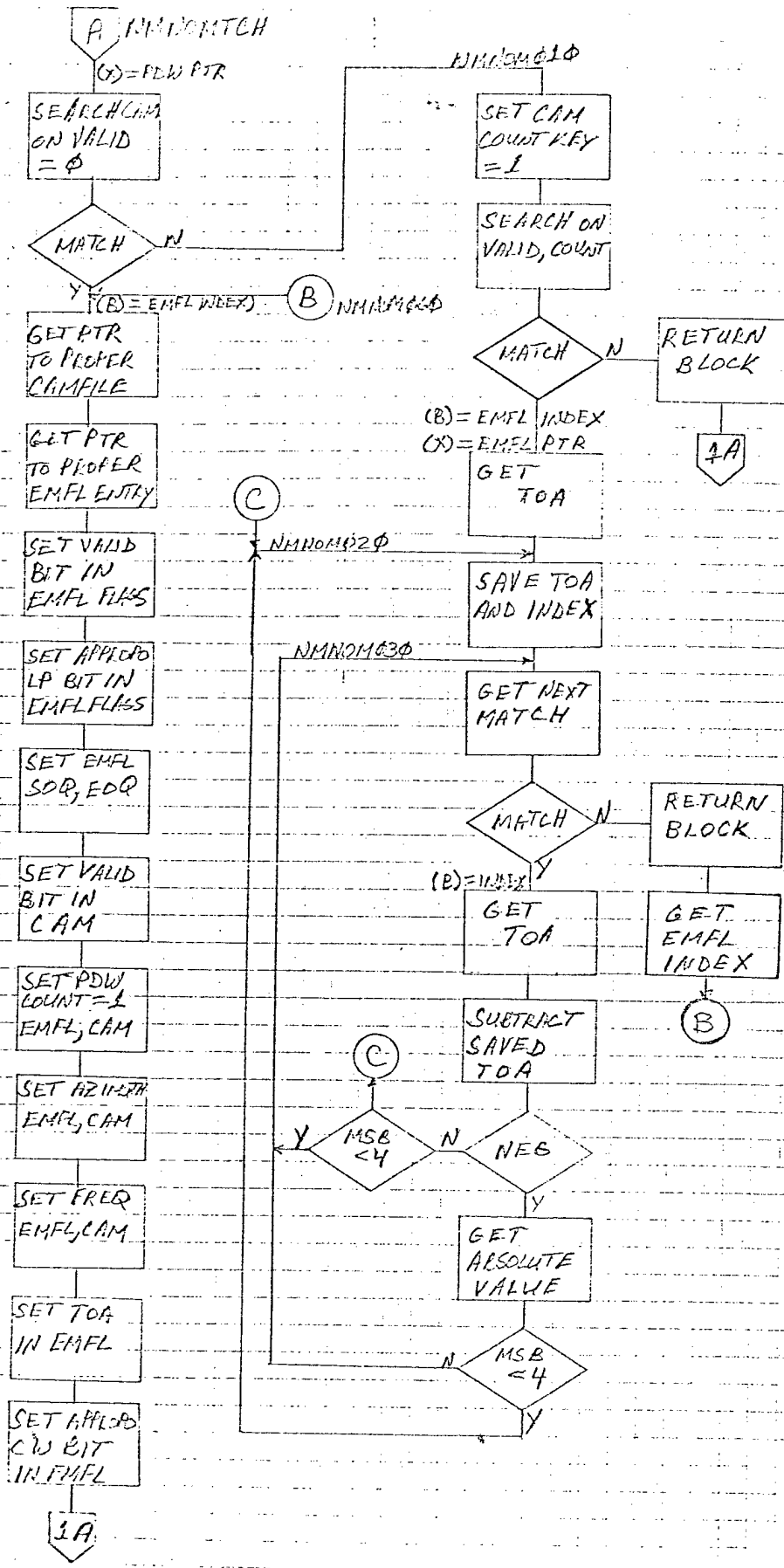

NO MATCH = EMFL FULL I.E. NEW EMITTER OVERFLOW

RAYTHEON	RAYTHEON COMPANY LEXINGTON, MASS 02173
PROGRAM ROUTINE SURVIVAL AS ACB 11/74	
NEWS SORTER - NEWSU	
49956	DATE
NUMBER OF MATCHES	SHEET 6 OF 19

A MULTMCH
 (B) = PTR TO SORTBUF
 (A) = COUNT OF ENTRIES
 (X) = PDW PTR

SORTBUF ENTRIES:

WD 0: ENFL INDEX
 WD 1: ΔAZ
 WD 2: ΔF
 WD 3: S

GET NEXT INDEX FROM EOF

GET ENFL ADDRESS

CALC $\frac{1}{2}AZ - AZ$ PDW AND SAVE

CALC $\frac{1}{2}F - F$ PDW AND SAVE

CALC $S = \Delta AZ + \Delta F$ AND SAVE

DONE

INSORT SORT BY S

1st = 2nd N → 2B

KEEP ALL S = 1st

INSORT SORT BY ΔAZ

1st = 2nd N → 2B

KEEP ALL ΔAZ = 1st

INSORT SORT BY ΔF

1st = 2nd N → 2B

END

RAYTHEON		RAYTHEON COMPANY LEXINGTON, MASS 02173	
PROGRAM ROUTINE / SUBROUTINE DESIGN			
NEWS SORTER - NEWS		DATE	
49956		PREPARED BY	
MULTMCH		SHEET 7 OF 19	

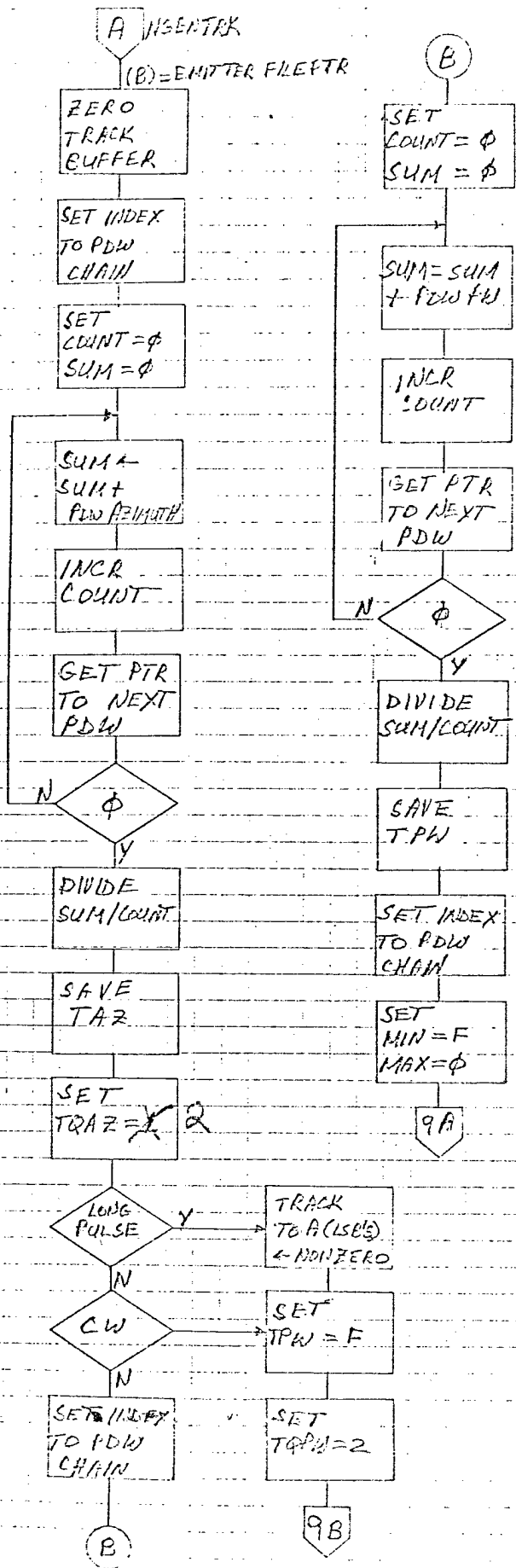

NON-ZERO TO A INDICATES LONG PULSE

RAYTHEON		RAYTHEON COMPANY LEXINGTON, MASS. 02173	
<small>PROGRAM ROUTINE SUBROUTINE FACILITY</small>			
ITEM SCPTP - NESU		DATE	
49956		ISSUED BY	
NUMBER GENERATE TRACK		SHEET 8 OF 19	

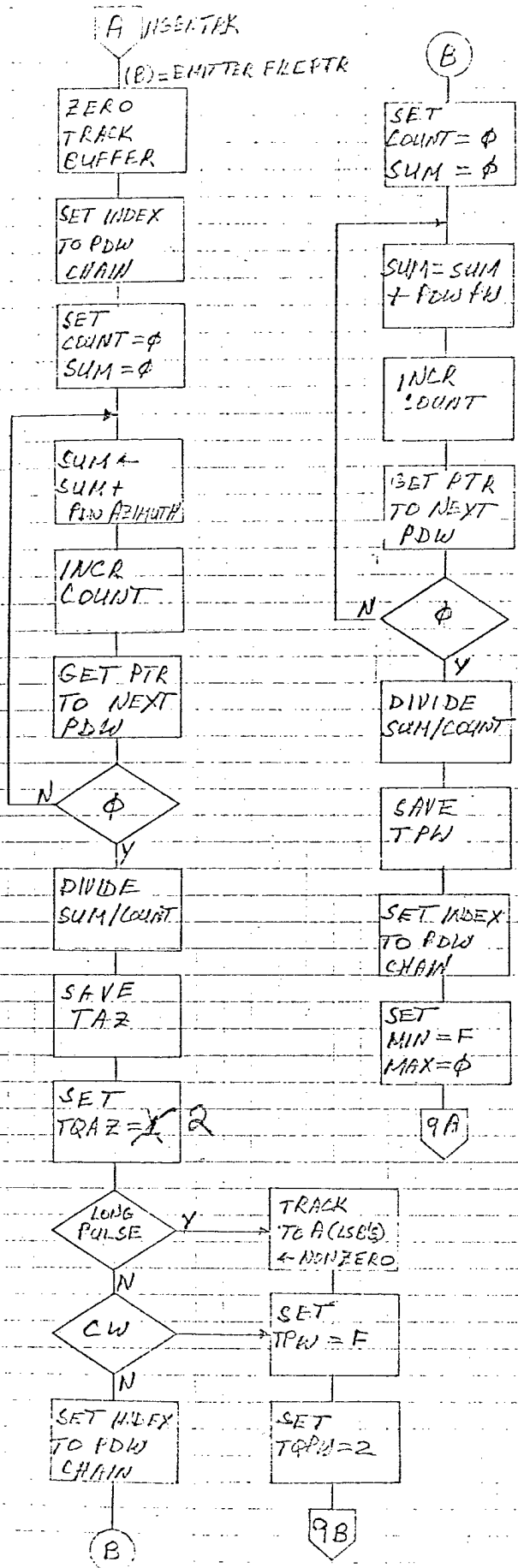

NON-ZERO TO A INDICATES LONG PULSE

RAYTHEON		RAYTHEON COMPANY LEXINGTON, MASS. 02173	
PROGRAM ROUTINE SUBROUTINE AGENCY			
WELS SCOTER - WESU		PREPARED BY	DATE
49956			
NUMBER GENERATE TRACK		SHEET 8 OF 19	

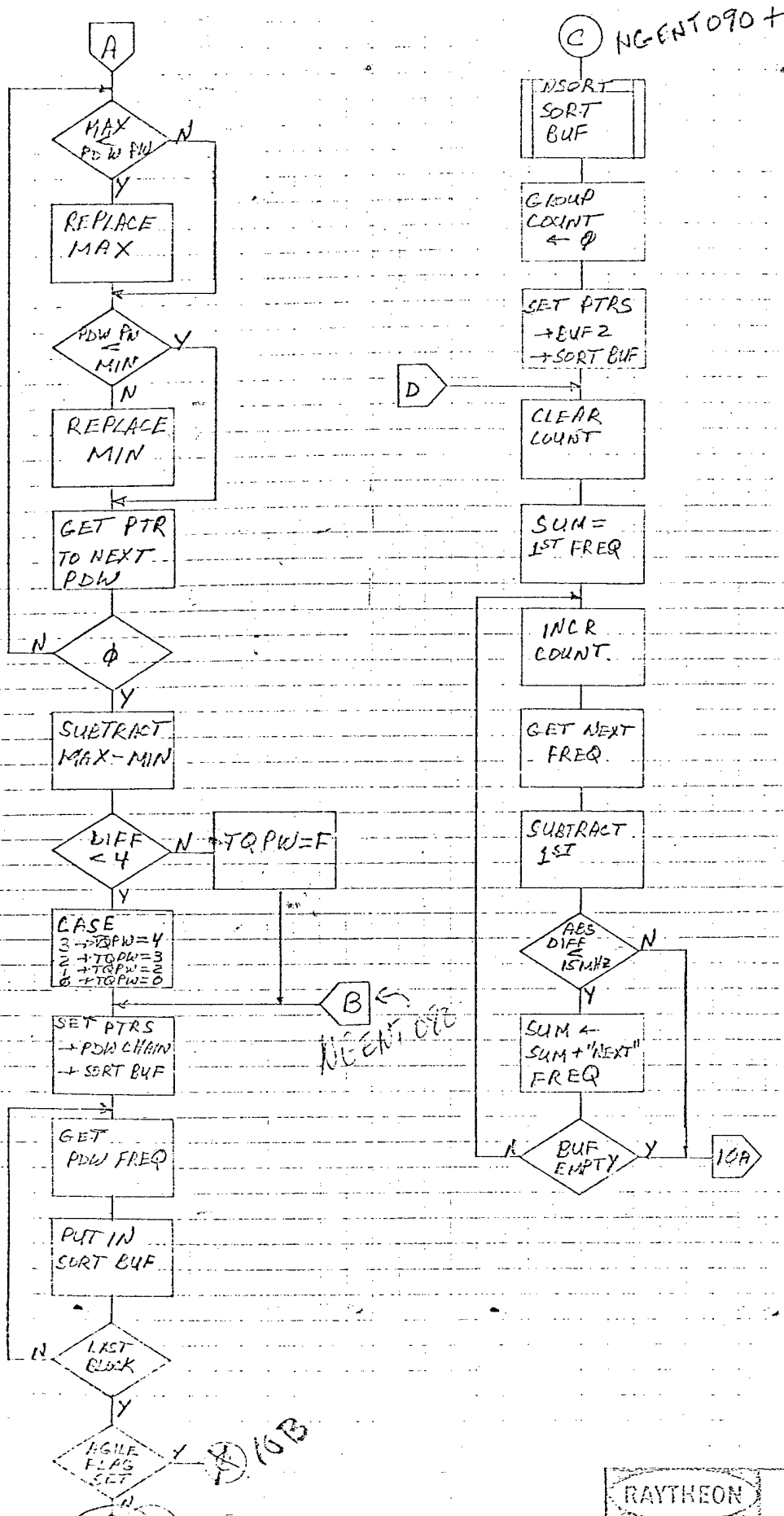

RAYTHEON		RAYTHEON COMPANY LEXINGTON, MASS. 02173	
1FWS SORTER - NESLI			
49956			
SHEET 9		OF 19	

PRI
CALCULATION

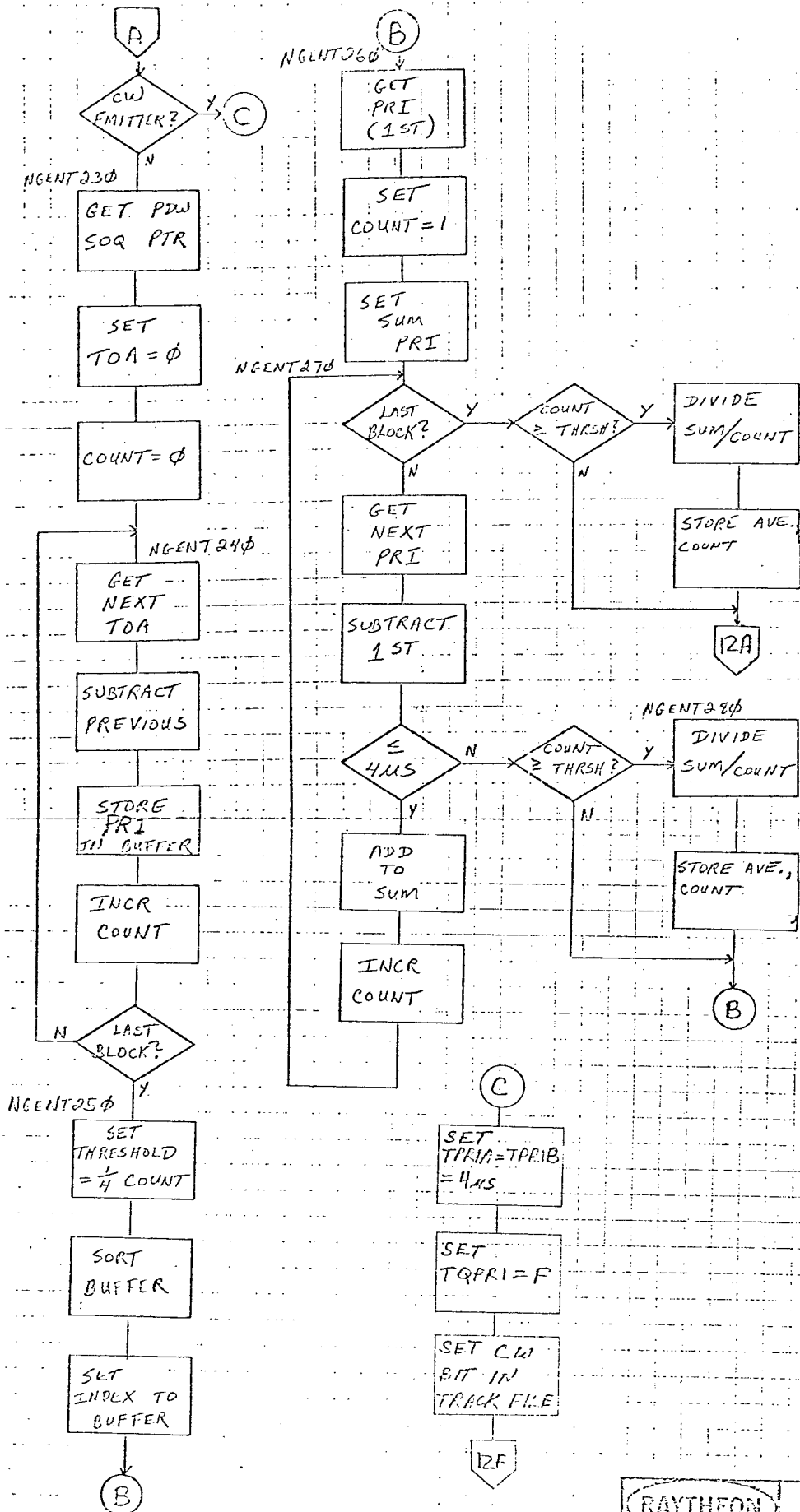

RAYTHEON	RAYTHEON COMPANY LEXINGTON, MASS. 02173
ENGINEERING & DESIGN SECTION	
NEWS SORTER - NESU	
49956	
NUMBER GEN TRK	SHEET 11 OF 19

PRI CHAIN
CALCULATION -
TOA WRAPAROUND
PROBLEM

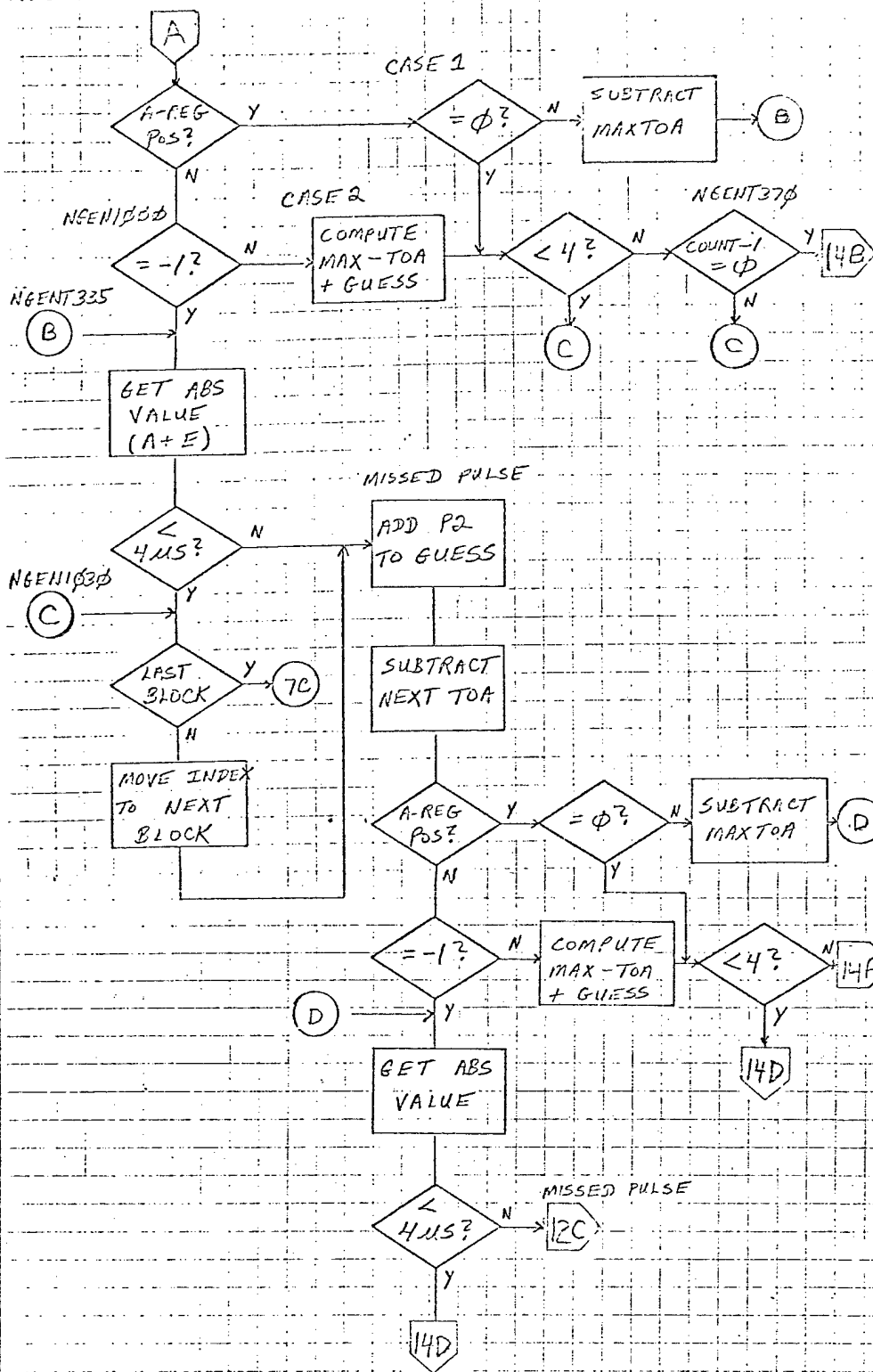

CASE 1 : GUESS = MAX - N N = 0, 1, 2, 3
 ACTUAL = M M = 3, 2, 1, 0

GUESS - ACTUAL = LARGE POS NO., I.E., MAX - N - M > 2¹⁶
 THEREFORE, NEED N + M < 4, ELSE POSSIBLE MISSED PULSE.
 IF A-REG POS AND NON-ZERO, THEN COMP ((GUESS - ACT) - MAX) = N + M

CASE 2 : GUESS = M M = 0, 1, 2, 3
 ACTUAL = MAX - N N = 3, 2, 1, 0
 GUESS - ACTUAL = LARGE NEG. NO., M - MAX - N
 THEREFORE, N + M < 4, ELSE ERROR.
 IF A-REG POS AND A ≠ -1, THEN
 MAX - ACT - GUESS = MAX - (MAX - N) + M = N + M

RAYTHEON		RAYTHEON COMPANY LEXINGTON, MASS. 02173	
LEWIS SORTER - NESU			
49956			
NUMBER		SHEET 13 OF 19	

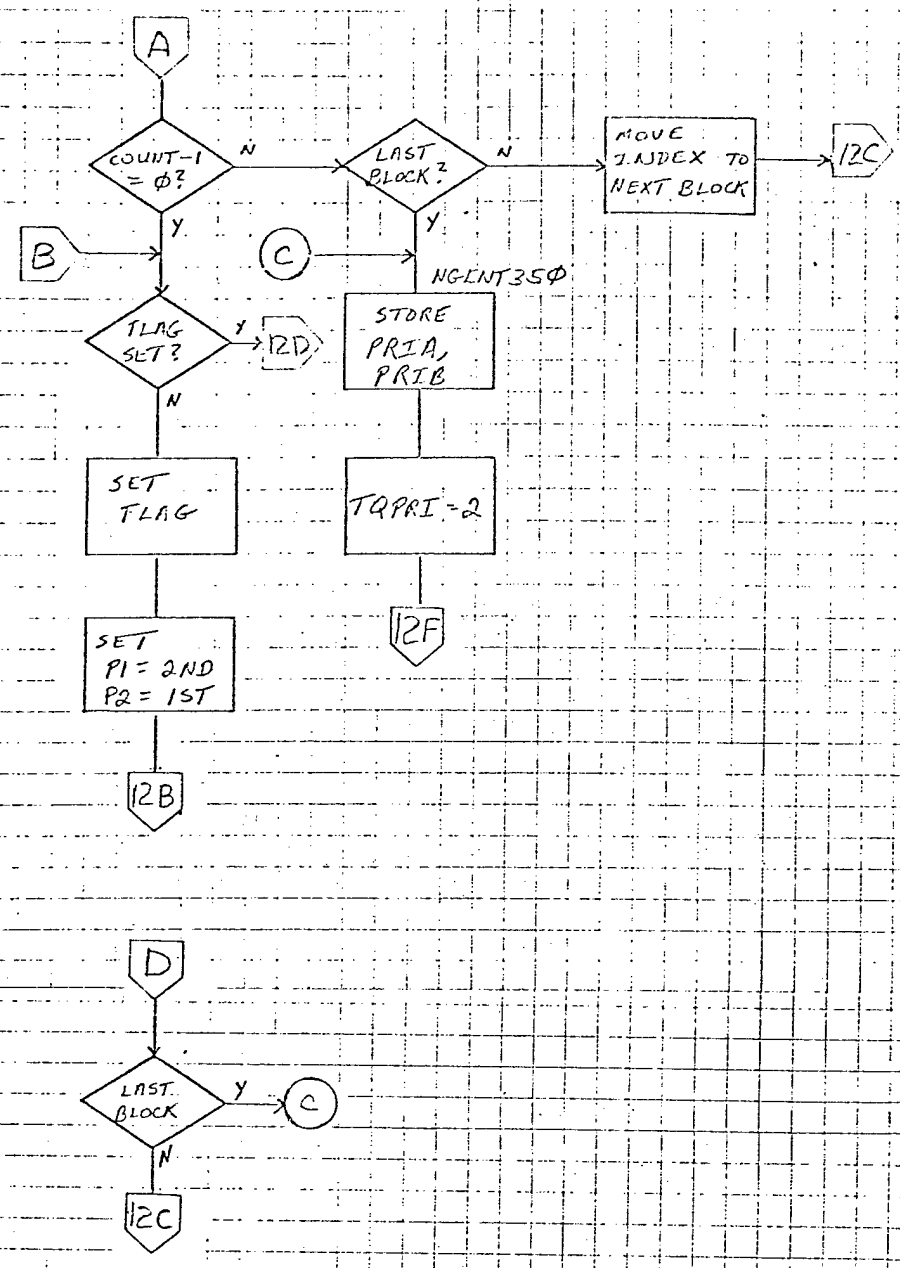

RAYTHEON	RAYTHEON COMPANY LEXINGTON, MASS. 02173
PROGRAM / ROUTINE / SUBROUTINE ACRONYM	
JENS SORTER - WESU	
49956	
NUMBER	SHEET 14 of 19

FLOW CHART

REMARKS

NSORT

SAVE
ENTRY SIZE

DECR
COUNT

CALL INDEX
TO COMPARE
TABLE

SET PER PASS
COUNT = COUNT

GET PTRS TO
- 1ST ENTRY
- 2ND ENTRY

INDEX INTO
LOAD/COMPARE
TABLE

EXEC
PROPER
LOAD

EXEC
PROPER
COMPARE

1ST <
2ND

SWAP
ENTRIES

MOVE "2ND"
PTR TO
NEXT ENTRY

PASS
COUNT - 1
= 0?

MOVE "1ST"
PTR TO
NEXT ENTRY

COUNT - 1
= 0

RETURN

INPUTS:
SORTBUF CONTAINS (E)-WORD ENTRIES
(E) = ENTRIES COUNT (GT 1)
(B) = ENTRY SIZE (MAX=4)
(A) = WORD TO SORT ON (4-3)

I.E. GET WORD
FROM 1ST ENTRY

I.E. COMPARE WITH
WORD FROM 2ND ENTRY

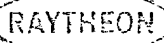
		RAYTHEON COMPANY LEXINGTON, MASS. 02173	
FEDERAL ACQUISITION SCHEDULE NUMBER			
1E115 SORTER - NESU			
49956	PREPARED BY	DATE	
NUMBER SORT		SHEET 15 of 19	

FLOW CHART

REMARKS

NTRKOUT

WAIT FOR
FREE HI
MSG BUFF

STORE PDW
PTR IN
MSG BUF

SET VALID
BIT IN
TRCK FILE

MOVE TRCK
FILE TO
MSG BUF

SEND NEW
EMITTER
ALERT TO SUP

RETURN

NTAOA DEC

GET PTR
TO 1ST
PDW

IS
IT
Φ

RETURN

AZ DEC
DEC AOA
FOR GIVEN
PDW

GET PTR
TO NEXT
PDW

AZ DEC

GET PDW
AZIMUTH

GET PROPER
AOA COUNT

Φ

DECR
AOA COUNT

RETURN



RAYTHEON COMPANY
LEXINGTON, MASS. 02173

1EWS SORTER - NDSU

49956

SHLT 16 OF 19

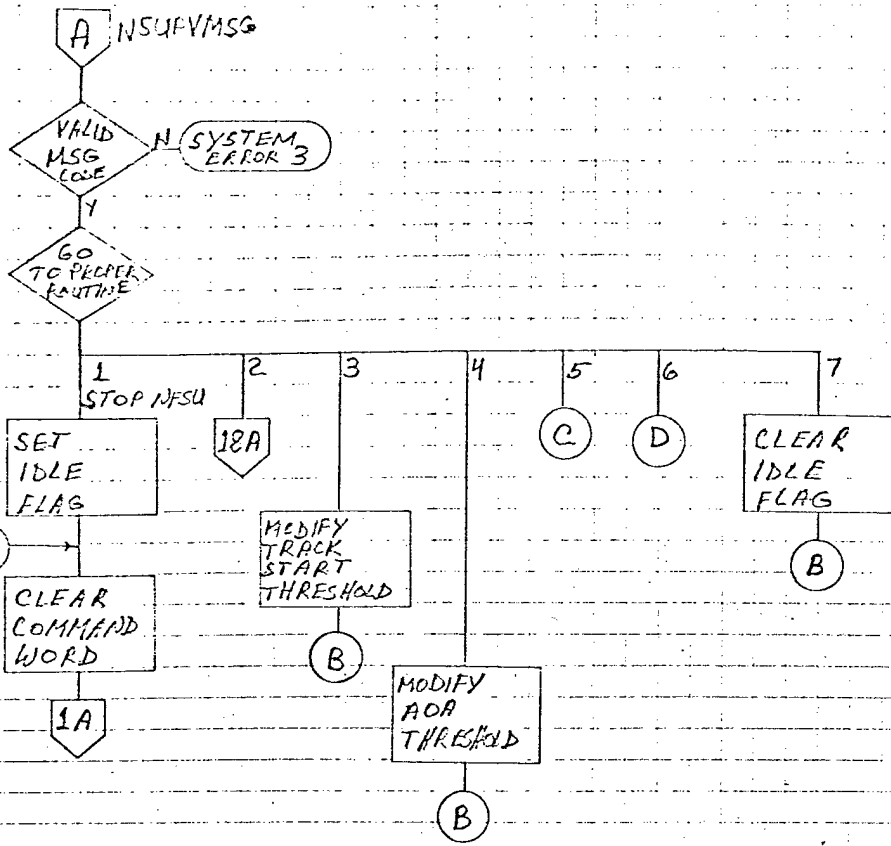

C AOA DUMP

D CAM DUMP

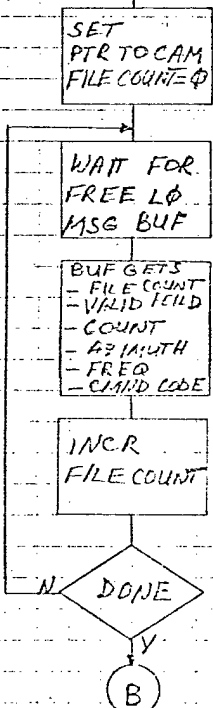
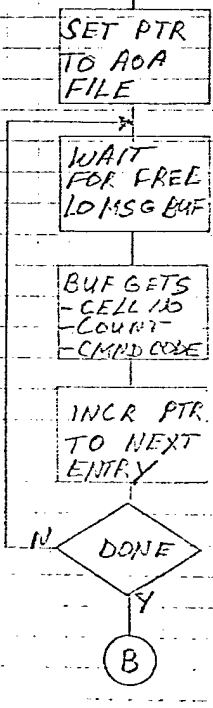

RAYTHEON		RAYTHEON COMPANY LEXINGTON, MASS. 02173	
PROGRAM/ROUTINE SUBROUTINE ACRONYM JWS SORTER - NFSU			
DATE PREPARED BY 49956	PREPARED BY		DATE
NUMBER SUPV CMMDS REQD		SHEET 17 OF 19	

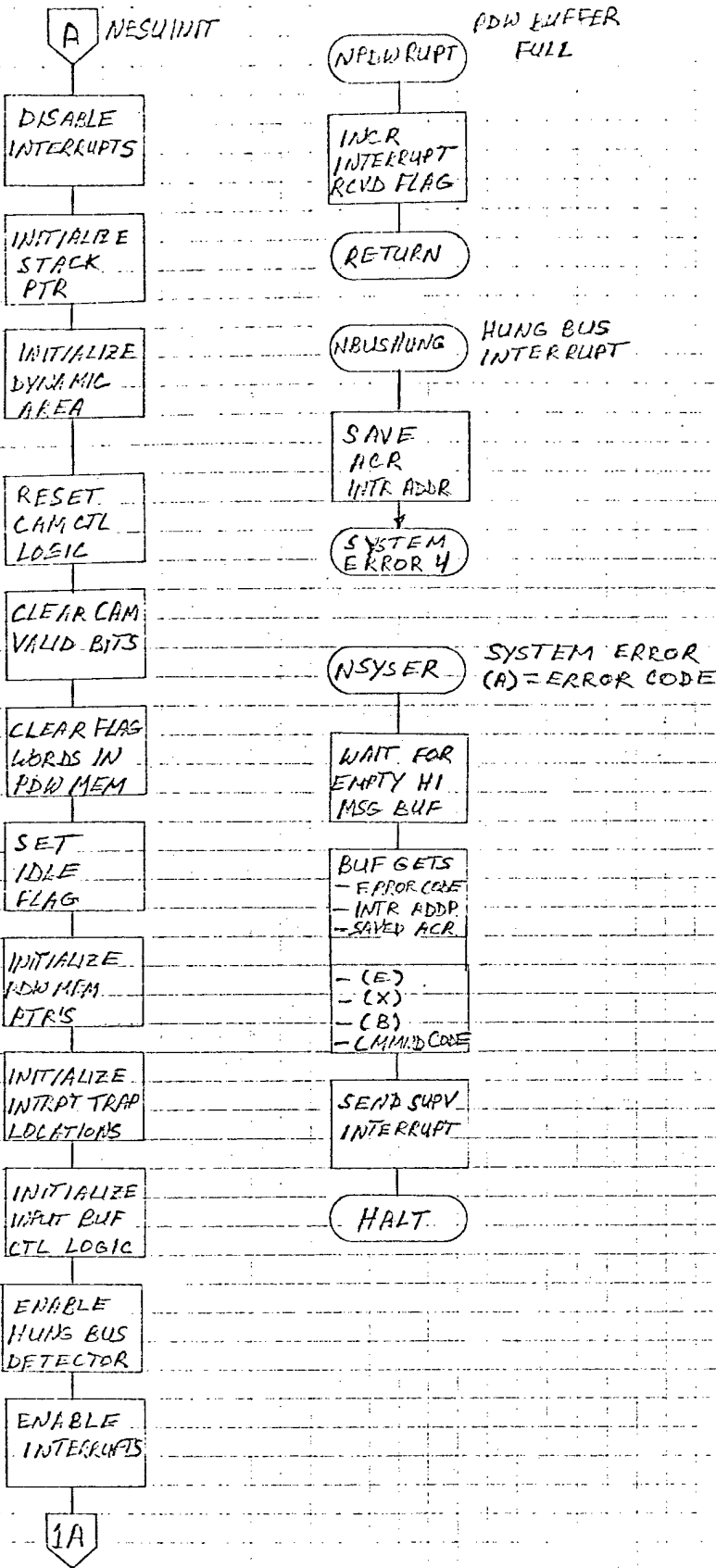

RAYTHEON		RAYTHEON COMPANY LEXINGTON, MASS. 02173	
PROGRAM ROUTINE OVERWRITE ACCOUNT			
JESU SORTER - NESU			
COPIES	49956	PREPARED BY	DATE
NUMBER	INITIALS	SHEET 12 OF 19	

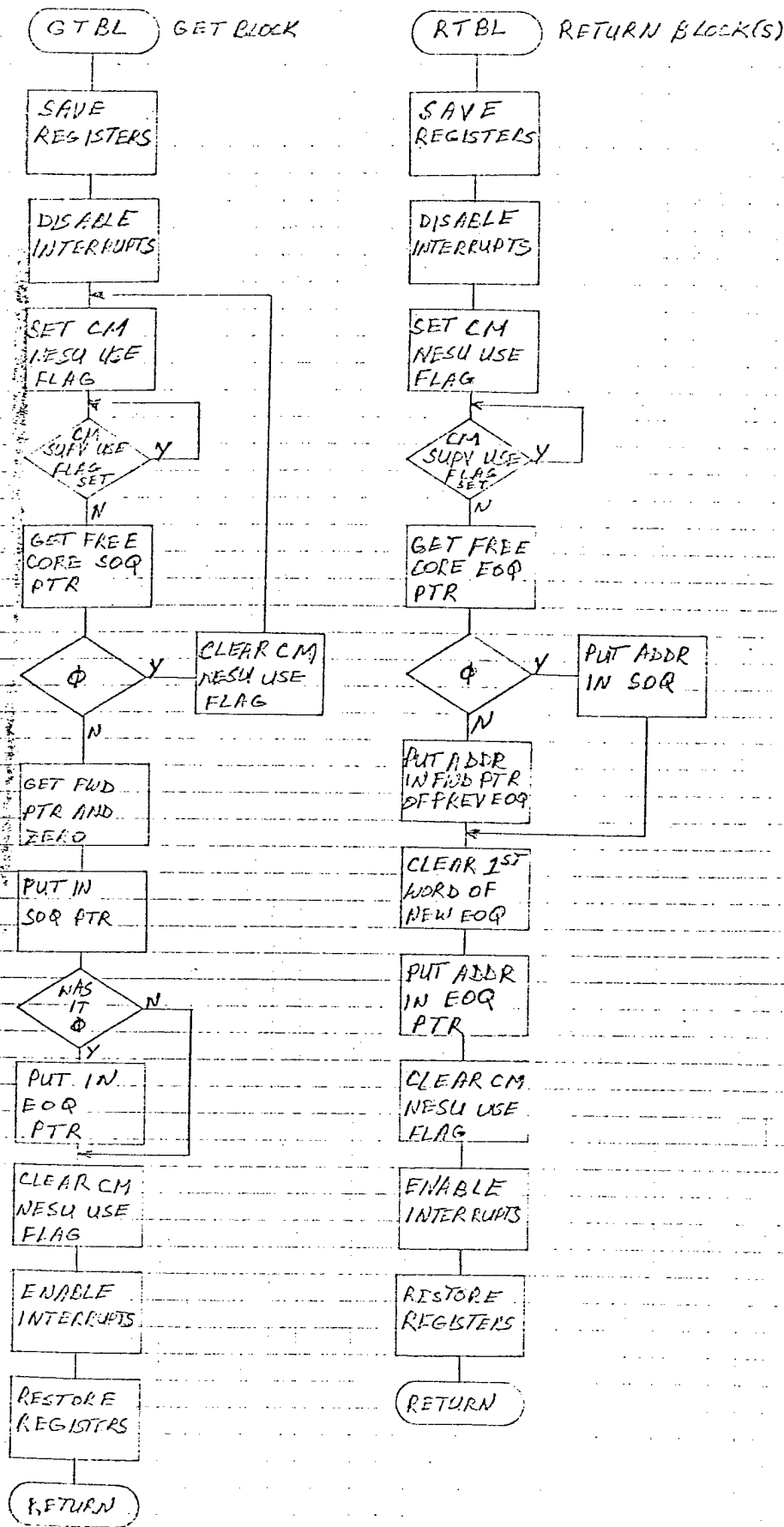

CM MEANS CORE MANAGER

		RAYTHEON COMPANY LEXINGTON, MASS. 02173	
PROGRAM/TITLE/NO. / SUBPROGRAM / ACRONYM NEWS SORTER - NESU			
NO. / REV. BY 49956	DATE		
NUMBER / CORE MANAGER	SHEET / 19 OF 19		