

LOAN DOCUMENT

PHOTOGRAPH THIS SHEET

DTIC ACCESSION NUMBER

LEVEL

INVENTORY

DOCUMENT IDENTIFICATION

DISTRIBUTION STATEMENT

H
A
N
D
L
E

W
I
T
H

C
A
R
E

ACCESSION FOR	
NTIS	GRAM
DTIC	TRAC
UNANNOUNCED	
JUSTIFICATION	
BY	
DISTRIBUTION/	
AVAILABILITY CODES	
DISTRIBUTION	AVAILABILITY AND/OR SPECIAL
A-1	

DISTRIBUTION STAMP

Reproduced From
Best Available Copy

19981223 079

DATE RECEIVED IN DTIC

DATE ACCESSIONED

DATE RETURNED

REGISTERED OR CERTIFIED NUMBER

PHOTOGRAPH THIS SHEET AND RETURN TO DTIC-FDAC

UNCLASSIFIED

NO DISTRIBUTION
STATEMENT

NADC
Tech. Info!

APPENDIX 26

SIGNAL SORTER (SS) SUPERVISOR DESIGN SPECIFICATION & FLOW DIAGRAMS
FINAL SOFTWARE REPORT

DATA ITEM NO. A005

Reproduced From
Best Available Copy

**INTEGRATED ELECTRONIC WARFARE SYSTEM
ADVANCED DEVELOPMENT MODEL (ADM)**

780 0987-26

PREPARED FOR:

NAVAL AIR DEVELOPMENT CENTER
WARMINSTER, PENNSYLVANIA

CONTRACT N62269-75-C-0070



ELECTROMAGNETIC
SYSTEMS DIVISION

1 OCTOBER 1977

UNCLASSIFIED

APPENDIX 26

SIGNAL SORTER SUPERVISOR DESIGN SPECIFICATION

FINAL SOFTWARE REPORT

DATA ITEM A005

INTEGRATED ELECTRONIC WARFARE SYSTEM (IEWS)
ADVANCED DEVELOPMENT MODEL (ADM)

Contract No. N62269-75-C-0070

Prepared for:

Naval Air Development Center
Warminster, Pennsylvania

Prepared by:

RAYTHEON COMPANY
Electromagnetic Systems Division
6380 Hollister Avenue
Goleta, California 93017

1 OCTOBER 1977

1.0 SCOPE

This document describes the design specifications of the IEWS Signal Sorter Supervisor Software.

2.0 APPLICABLE DOCUMENTS

ESD-SB-001	Signal Sorter Integrated Electronics Warfare System, Rev. 4
WS-8506	Requirements for Digital Computer Program Documentation, Rev. 1, dated 1 November 1971.
CG-983645	IEWS Signal Sorter Computer Program Performance Specification
CG-983645	IEWS Signal Sorter NESU Software
5413-IEWS:75:03	IEWS Input Buffer Functional Specification, Rev. B
5413-IEWS:75:05	IEWS Signal Sorter Supervisor Design Specification, Rev. B
5413-IEWS:75:06	IEWS Signal Sorter Track Correlator Design Specification, Rev. A
RP-16	Microprocessor Manual

3.0 REQUIREMENTS

3.1 FUNCTION ALLOCATION/DESCRIPTION

The Supervisor consists of the following modules:

- Initialization
- Task Manager
- Core Manager
- Update
- NESU Message Handler
- SC Message Handler
- Aux. Functions

These modules make up a multi-task priority real-time operating system in which each of the functions of the Supervisor is performed by one or more tasks.

3.1.1 INITIALIZATION MODULE

The Initialization module performs the initialization of the Supervisor software and hardware including the Input Buffer, the FIFO, and the Track Correlator. This module is used both at initial program load time and upon receipt of a SC Initialization Command.

3.1.2 TASK MANAGER MODULE

The Task Manager Module performs the function of task scheduling and dispatching according to priority. The module consists of two subroutines: A Task Scheduler and a Task Dispatcher. These subroutines maintain four task queues, each queue corresponding to a different task priority. Tasks are placed on the queues by other modules in the system by calling the Task Scheduler and giving it a Task Control Block (TCB) and a priority number. Initiation of execution of a task is done by searching for a non-empty queue starting with the highest priority one. If more than one TCB is contained on a queue, they are handled in a First-In-First-Out basis. Control is then transferred to the address contained in the first TCB found.

3.1.3 CORE MANAGER MODULE

The Core Manager Module performs the maintenance of available core blocks for the Supervisor modules. This module consists of two subroutines: a get core block routine and a return core block routine. Each core block consists of five contiguous words and is initially placed in the available core block queue common to both the Supervisor and the NESU. These blocks are used for TCB's and for

storing PDW's. Blocks are obtained by the modules by calling the get core block routine, and are returned to the available core block queue by calling the return core block routine.

3.1.4 UPDATE MODULE

The Update Module performs the updating of all track files in the Track Correlator. This module consists of a Schedule Update subroutine and four tasks: Initiate Update, Start Update, Update Track and Time-out Check. The Update module maintains four update queues, each queue corresponding to a different update priority. Each entry in the queues consists of two words, one for each track file to be updated. Entries are placed on the queues by calling the Schedule Update routine. This routine in turn schedules the Start Update task if less than five updates are in progress. The Start Update task searches the update queues for the highest priority update scheduled, initializes the Emitter Table Entry, and sets the count in the Track Correlator for the file to be updated. The Initiate Update task is scheduled periodically by the Real Time Clock Interrupt Handler. It schedules track files for update depending on category and last time of update. The Update Track is scheduled by the NESU interrupt handler whenever the specified number of PDW's have been received for a track file to be updated. This task performs the actual updating of the track files in the Track Correlator. The Time-Out Check task checks for track files in the update process which have not received any PDW's within the trap time.

3.1.5 NESU MESSAGE HANDLER MODULE

The NESU Message Handler module processes all messages generated and received from the NESU. This module consists of the NESU Interrupt Handler, the New Track Start task, and the low level NESU Message handler. The NESU Interrupt Handler processes the NESU generated interrupt signifying that a high level message has been

placed in one of the two high level message buffers. The high level message is either a New Emitter Start message or a Supervisor PDW message. If it is a New Emitter Start message, the NESU Interrupt Handler schedules the New Track Start task. If the message is a Supervisor PDW, the interrupt handler links it to the proper track file.

The low-level NESU message handler is a task scheduled by the Message Polling task and processes all of the low level messages generated and sent by the NESU. These consist of the CAM file dump and the AOA file dump.

3.1.6 SC MESSAGE HANDLER MODULE

The SC Message Handler Module processes all of the messages generated and sent by the SC. This module consists of the SC Interrupt Handler and the SC Message Handler. The SC Interrupt Handler processes the SC interrupt which signifies a high level message from the SC. These messages consist of the Start, Pause, Initialize, Pause NESU, and Initialize and Start NESU Commands. Depending on the message, the SC interrupt handler sets the necessary flags and/or schedules or transfers control to the necessary routines. The SC Message Handler processes all low level SC messages and is scheduled by the Message Polling task.

3.1.7 AUXILLIARY FUNCTIONS

The auxilliary functions consist of the Message Polling task and the test of the interrupt handlers. The Message Polling task checks both the SC and NESU low level message buffers for an incoming message. If a message is present, it schedules the SC Message Handler or the NESU Message Handler which perform the message processing. The Real Time Clock Interrupt Handler maintains the system clock which contains current time. Each "tick" corresponds to 250 Oms

On each interrupt the RTC Interrupt Handler sets the NESU purge flag and schedules the Time-Out Check task. Every fourth interrupt, or once per second it schedules the Initiate Interrupt task. The Bus Hung, Watchdog Timer, and Panic Button interrupts cause the Supervisor to send an error message to the SC and halt. The IB less than 1/4 full and greater than 3/4 full cause a TBD.

3.1.8 TASK STRUCTURE

Figure 3.1 shows the assignment of tasks by priority level with level 0 being the highest priority. The task priority structure is a software extension of the hardware interrupt structure allowing a more modular and self-contained design of independent modules. The Task Manager acts as a system utility allowing tasks to schedule other tasks without regard as to whether any higher priority tasks are waiting execution. A given task may also be scheduled many times before it is executed the first time.

The Message Polling task runs as a background task continually scheduling itself. When a message is detected in one of the input message buffers, it schedules either the EC or NESU Message Handler. The execution of the other tasks is initiated by an interrupt from either the RTC or NESU.

3.2 FUNCTIONAL DESCRIPTION

3.2.1 INITIALIZATION MODULE

The Initialization module is first started by the SC which performs an Initialize and New Start sequence with the address of the Initialization module (INITA) in location zero. The Initialization module in turn performs an Initialize and New Start sequence on the NESU microcontroller with the address of its Initialization module in its location zero. It then initializes and clear the files in the Input Buffer and the Track Correlator and all of the files and queues

in the Supervisor. It then sets the Idle flag, schedules the Message Polling task and enables interrupts. The same sequence of initialization is followed when the SC Interrupt Handler detects a Initialization command from the SC.

3.2.2 TASK MANAGER

A task is scheduled by executing the following calling sequence:

JSUB (=SCHED)

The X register must contain the address of the TCB and the B-register must contain the priority level. The TCB consists of five words:

Word 0	Used by task manager for linking
Word 1	Task entry point
Word 2-4	Used by scheduling routine to pass parameters to task

Each task is responsible for returning the TCB to available storage by calling the Return Block routine. When a task has completed execution it must execute a jump to the Task Manager as follows:

JUMP (=DISP)

The Dispatcher then transfers control to the highest priority task awaiting execution using the second word in the TCB and passes the TCB address to the task in the X-register.

The Task Manager maintains four pairs of pointers for the four task queue, one queue per priority level. Each pair consists of a Start of Queue (SOQ) pointer and an End of Queue (EOQ) pointer. The SOQ pointer contains the address of the first TCB while the EOQ pointer contains the address of the last TCB in the queue. If the queue is empty, both pointers are set to zero. The first word in each TCB contains the address of the next TCB in the queue except for the last TCB whose first word contains zero. The Scheduler uses the task priority level in the B-register to select the proper EOQ pointer which contains the address of the last TCB. The new TCB address is

JSUB

(=SCUP)

with the track number in the A-register. This subroutine is called by the Start New Track task and the Initiate Update task.

The Schedule Update subroutine uses the track number to select the proper Emitter Table Entry. The emitter is then placed on the update queue depending on the New Emitter flag bit and the Update Priority bits. The Update Queue consists of four FIFO queues, each queue corresponding to a different priority; New Emitter, high data rate - threat, high data rate, and low data rate. There is a SOQ and a EOQ pointer for each queue which point to the first and last entries in the queue, respectively. Each entry in the queue consists of the last two words in the Emitter Table entries. If less than five updates are in progress, the Schedule Update subroutine schedules the Start Update task.

The Initiate Update task is scheduled by the RTC Interrupt Handler once per second (every four clock ticks). This task searches the Emitter Table for all emitters which are due for update. For each emitter found, the Initiate Update task calls the Schedule Update Subroutine which places the emitter on the Update Queue. An emitter is considered due for update if the flag bits indicate that the emitter entry is in use, not in update, the don't update bit is set, and the current time minus the last PDW/update time is equal or greater to the priority.

The Start Update task is scheduled by the Schedule Update subroutine and the Update task. This task searches the Update Queue for the highest priority entry and sets TCOUNT for that emitter in the Track Correlator Track Data Memory. If the New Emitter Flag bit is set in the Emitter Table Entry, the count is set to 31_{10} , otherwise it is set to 11_{10} . The PDW count in the Emitter Table entry is also set to 30_{10} or 10_{10} and the in update flag bit is set. The entry is removed from the Update Queue and the Update Count is incremented. If the Update Count is less than five, the Update Queue

is searched for the next highest priority entry and the process repeated.

The Update task is scheduled by the NESU Interrupt Handler when the last PDW has been received for updating an emitter. The third word of the TCB used to schedule the Update task must contain the track number of the emitter to be updated. If the New Emitter flag bit in the Emitter Table entry is set, all parameters are updated, otherwise only Pulse Width, Frequency, and PRI are updated. The new parameters are written into the TDM, and the In Update, New Emitter, and Time-Out flag bits are cleared. If the Throttled flag bit is set, the Throttle File entry in the Input Buffer is also updated. If the update priority of the Emitter Table entry is one, a Pulse Train Descriptor Word Message is sent to the SC.

The Time-Out Check task is scheduled by the RTC Interrupt Handler every 500 ms. This task searches the Emitter Table for all entries in the update process which have not received a PDW within the trap time. The trap time is 500 ms. for high data rate emitters and the SC specified purge time for all others. All high data rate emitters found will have their priority set to a low data rate emitter. Any low data rate emitter found will have its time-out flag set. The next time the Time-Out Check task is scheduled, it will send a File Delete Request Message to the SC for each entry with its time-out flag set, will return any core blocks used to store PDW's, and will set the don't update flag and clear the time-out flag.

3.2.5 NESU MESSAGE HANDLER MODULE

The NESU Interrupt Handler processes all NESU Interrupts which signal the presence of a high priority message from the NESU in one of the two NESU Input Buffers. The message may be either a New Emitter Start Message or a Supervisor PDW message. If a New Emitter Start Message is received, the NESU Interrupt Handler schedules the Start New Track task. If the message is a Supervisor PDW message, the PDW

is linked to the Emitter Table entry specified by the track number. If the number of PDW's linked equals the PDW Count in the Emitter Table entry, the Update task is scheduled with the track number in the third word of the TCB.

There are two NESU high priority input buffers of ten words apiece. The first word is used as a flag whose contents have the following meaning:

- 0 Buffer Empty
- 1 New Emitter Start Message
- 2 Supervisor PDW Message

The format for a New Emitter Start Message is:

word 0	-----
word 1	pointer to PDW list
word 2	TAZ
word 3	0
word 4	TPRIA
word 5	TPRIB
word 6	TPW
word 7	TQPRI TQPW TQF TQAZ
word 8	TF
word 9	TFAG TCW

The contents of words 2 through 9 are in the format of the TDM file.

The format for a Supervisor PDW Message is:

- word 0 2
- word 1 Pointer to PDW block
- word 2 File number
- word 3-9 not used

The PDW block pointed to by word 1 has the following format:

- word 0 not used
- word 1-4 Normal PDW format

The flag word in the message buffer is set by the NESU when it places a message in the buffer, and it is reset to zero by the Supervisor when the message has been processed.

The Start New Track task gets an unused track number from the Track Correlator. This is used to write a new track file into the TDM using the information in the New Emitter Start Message and to initialize an Emitter Table entry. If no unused file exists, a TBD message is sent to the SC. If the emitter requires throttling, the throttle count is calculated and a throttle file number is requested from the Input Buffer. The throttle file is then written into the Input Buffer, the Throttle Table entry initialized and a Throttle Alert Message sent to the SC. If no vacant throttle file exists, a TBD message is sent to the SC. A New Emitter Alert message is sent to the SC, and the Schedule Update subroutine is called.

The NESU Message Handler is scheduled by the Message Polling task when a low priority message is found in NESU low priority message buffer.

The low priority messages consist of a CAM File Dump message and an AOA File Dump message. If a CAM File Dump message is found, the NESU Message Handler sends a CAM File Dump message to the SC. If an AOA File Dump message is found, an AOA Readout message is sent to the SC.

The NESU low priority message buffer consists of four words where the first word is a flag word whose contents indicate the following:

0	Buffer empty
1	CAM File Dump Message
2	AOA File Dump Message

The other three words contain the message indicated by the flag word. The format for a CAM File Dump Message is:

word 0	1
word 1	NESU CAM File Number

word 2 MSB=valid bit, bits 0-9 = frequency
word 3 bits 8-12 = azimuth, bits 0-5 = count

The format for an AOA File Dump Message is:

word 0 2
word 1 Cell number
word 2 PDW Count

The flag word is set by the NESU when it places a message in the buffer. The flag word is cleared to zero by the Supervisor when the message has been processed.

3.2.6 SC MESSAGE HANDLER MODULE

The SC Interrupt Handler processes all SC Interrupts and the high priority messages they signal. These messages consist of the Start Command, Pause Command, Initialize Command, Pause NESU Command and the Initialize and Start NESU Command. Following is a summary of the actions taken on receipt of each message:

Start Command	Clear Idle flag Send Start Message to NESU Enable PE/STE channel in Input Buffer
Pause Command	Set Idle flag Disable PE/STE channel in In- put Buffer Send Pause message to NESU
Initialize Command	Jump to Initializer
Pause NESU Command	Send Pause message to NESU
Init. and Start NESU Command	Send Initialize message to NESU Send Start message to NESU

The SC high priority message buffer consists of 16 words where the first word contains a flag and a word count, and the second word contains a command code. The message formats and command codes are specified in the IEWS Signal Sorter Computer Program Performance Specification - CG-983645.

The SC Message Handler task is scheduled by the Message Polling task whenever a message is detected in the SC low priority input message buffer. This task processes all low priority SC messages. Following is a summary of actions taken on receipt of each low priority message:

CAM File Dump Command	Send CAM File Dump Message to NESU
AOA Readout Request	Send AOA Readout Request Message to NESU
File Dump Request	Send File Dump Request Message to NESU
UPDW Command	Enable transfer to NESU words to Aux. Interface in Track Correlator
Synthetic PDW	Stores Synthetic PDW into Input Buffer
NESU Track Threshold	Send Modify Track Start Threshold Message to NESU
Quality Bit Modification	Write quality bits into TDM for file specified
Purge Time Modify	Change priority in Emitter Table for file specified, change purge time
PTDW Request	Read Track file from TDM and send Pulse Train Descriptor Word to SC
SPDW Request	Set THRSC, TTAMP, and TCODE in TDM for file specified
SPDW Stop	Clear THRSC in the TDM for the file specified
NEPDW Request	Send TBD message to SC and return the core blocks to storage
Delete Track File	Clear the valid bit in the TDM and the used bit in the Emitter Table for the file specified

Frequency Modification	Write the frequency into the TDM file specified
PRI Modification	Write the PRIA and PRIB into the TDM file specified
Pulse Width Modification	Write the PW into the TDM file specified
Throttle File Modification	Write the throttle information into the Input Buffer Throttle File specified
AOA Threshold Modification	Send an AOA Threshold Modification message to the NESU
Create Track File	Write track file information into TDM file specified, initialize Emitter Table entry Send Confirm File Creation to SC

The SC low priority message buffer consists of sixteen words where the first word contains a flag and word count and the second word contains a command word. The formats and contents of the low priority SC messages are described in IEWS Signal Sorter Computer Program Performance Specification - CG-983645.

3.2.7 AUXILIARY FUNCTIONS

The Message Polling task is initially scheduled by the Initialization module. This task checks the SC low priority message buffer for an incoming message and schedules the SC Message Handler task if the flag is set. It then checks the NESU low priority message buffer for an incoming message and schedules the NESU Message Handler if the flag is set. It then resets the Watchdog Timer and schedules itself.

The Real Time Clock Interrupt Handler processes all RTC Interrupts. These occur once every 250ms. At each interrupt, the handler increments the system time, sets the NESU purge flag, and schedules the Time-Out Check task. Every fourth interrupt it schedules the Initiate Update task. If the Idle flag is set, the handler none of these actions are taken and the handler simply does an interrupt return.

The Bus Hung Interrupt Handler processes the bus hung interrupt. When an interrupt occurs, the handler sends a TBD message to the SC, saves all registers and halts the Supervisor.

The Watchdog Timer Interrupt Handler processes watchdog timer interrupts in the same manner as the Bus Hung Interrupt Handler.

The Panic Button Interrupt Handler processes panic button interrupts in the same manner as the Bus Hung Interrupt Handler.

The IB Interrupt Handler processes IB less than 1/4 full and greater than 3/4 full interrupts. Occurrence of these interrupts causes a TBD action.

3.2.8 EMITTER TABLE

The Emitter Table is used by the Supervisor to maintain and update track files. There are 128 entries in the table, one entry for each track file in the TDM. Each entry consists of nine words in the following format:

word 0	Flags
word 1	Update PDW SOQ pointer
word 2	Update PDW EOQ pointer
word 3	Update PDW count
word 4	Last PDW/Update Time
word 5	New Track PDW pointer
word 6	Throttle File number
word 7	Update Queue word 1
word 8	Update Queue word 2 - file number

Flag Bits (if set):

- 15 in use (valid)
- 14 in update process
- 13 throttled file
- 12 don't update
- 11 new emitter
- 10 time-out
- 7 - 0 update priority

Words 1 and 2 point to the PDW's used for performing an update. Word 3 contains a count which is used to keep track of the number of PDW's in the update list. Word 4 contains the time (internal) of the last PDW or update and is used to decide when to start the next update. Word 5 points to the first PDW in the chain of ten PDW's used by the NESU to start a new emitter. Word 6 contains the Input Buffer file number for a throttled emitter. Words 7 and 8 are used as an entry on the Update Queue.

3.2.9 THROTTLE TABLE

The throttle Table is used to maintain the Input Buffer Throttle File. It contains eight 2-word entries, one for each file in the IB. The format of each entry is:

- word 0 TDM File number
- word 1 Throttle Count

3.3. STORAGE AND PROCESSING ALLOCATION

Table 3.1 summarizes the memory storage and processing time for the Supervisor routines.

<u>ROUTINE</u>	<u>MEMORY SIZE</u>	<u>PROCESSING TIME</u>
Initialization	300 words	10 ms
Scheduler	30 words	90 micro-seconds
Dispatcher	40 words	100 micro-seconds
Get Block	20 words	60 micro-seconds

<u>ROUTINE</u>	<u>MEMORY SIZE</u>	<u>PROCESSING TIME</u>
Return Block	20 words	60 micro-seconds
Schedule Update Sub-routine	30 words	90 micro-seconds
Initiate Update task	40 words	3 ms
Start Update task	80 words	150 micro-seconds
Update Track task	500 words	3 ms
Time-out Check task	40 words	3 ms
NESU Interrupt Handler	50 words	100 micro-seconds
Start New Track task	200 words	600 micro-seconds
NESU Message Handler	100 words	150 micro-seconds
SC Interrupt Handler	200 words	200 micro-seconds
SC Message Handler task	1000 words	120 micro-seconds
Message Polling task	30 words	250 micro-seconds
RTC Interrupt Handler	50 words	300 micro-seconds
Bus Hung Interrupt Handler	20 words	60 micro-seconds
Watchdog Timer Interrupt Handler	20 words	60 micro-seconds
Panic Button Interrupt Handler	20 words	60 micro-seconds
IB Interrupt Handler	TBD	TBD
Emitter Table	1152 words	N/A
Throttle Table	16 words	N/A
Free Core Storage	2450 words	N/A
TOTAL	6378 words	

TABLE 3.1
STORAGE AND PROCESSING TIME ALLOCATION

Processing speed of the Supervisor is a function of the number of updates being performed, the number of new emitters being started, and the number of messages being sent and received to and from the SC and the NESU. In a new-start situation where 30 emitters are being started and updated, the processing load per second is as follows:

NESU Interrupt Handler	93 ms
Start New Track task	18 ms
Schedule Update Subroutine	2.8 ms
Start Update task	4.5 ms
Update Emitter task	90 ms
Scheduler	8.1 ms
Dispatcher	9.0 ms
TOTAL	225.3 ms./sec.

In a steady-state situation where 60 emitters are being updated per second and 5 emitters are being started per second, the processing load is:

NESU Interrupt Handler	75.7 ms
Start New Track task	3.0 ms.
Schedule Update Subroutine	5.85 ms
Initiate Update task	3.0 ms
Start Update task	9.75 ms
Update Emitter task	195.0 ms
Scheduler	12.24 ms
Dispatcher	13.6 ms
TOTAL	318.13 ms./sec.

PRIORITY LEVEL

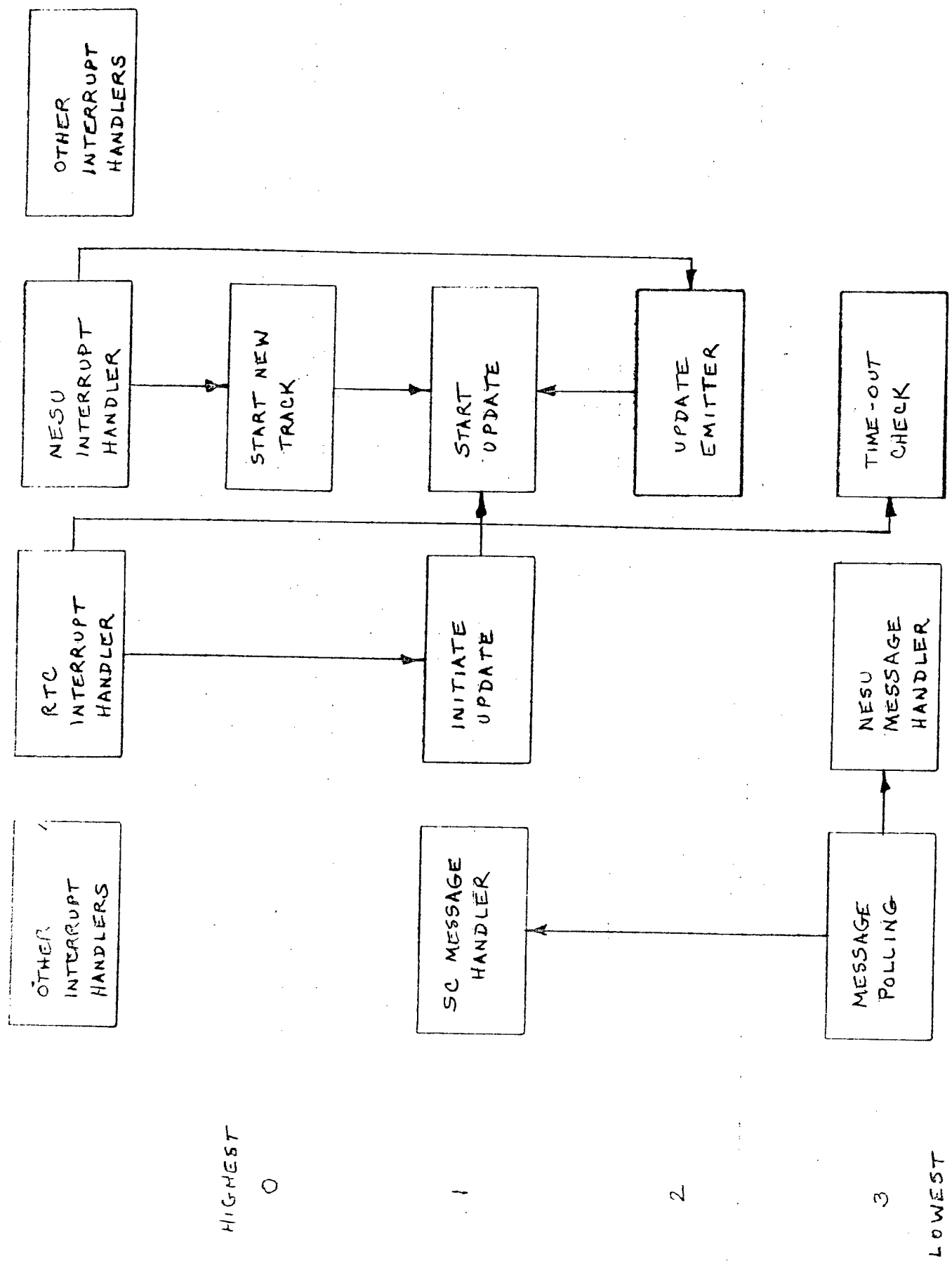

SUPERVISOR TASK SCHEDULING

FIGURE 3.1

3.4 FUNCTIONAL FLOW

Figure 3.1 shows the flow of control and task priority assignments in the Supervisor. Control is transferred from one task to another by scheduling as indicated by the arrows. All processing is initiated by either interrupts or receipt of a message. The interrupts received in order of priority are:

- Bus Hung
- Watchdog Timer
- Panic Button
- SC Message
- New Emitter Alert
- Real Time Clock
- IB 3/4 full
- IB 1/4 full

The Bus Hung, Watchdog Timer, and Panic Button interrupts normally indicate a hardware or software malfunction which is unrecoverable. The Bus Hung interrupt occurs if there is no response when the software attempts to address memory or a hardware unit. The Watchdog Timer interrupt occurs if the software does not reset the Watchdog Timer within a TBD interval. The Panic Button interrupt is caused by an operator either because the Sorter is malfunctioning or to stop the Sorter. The SC Message interrupt indicates the arrival of a high priority SC message and is caused by the SC. The New Emitter Alert indicates the presence of a high priority NESU message and is caused by the NESU. The Real Time Clock interrupt occurs every 250 ms. and is generated by an external Real Time Clock signal. The IB 3/4 full and IB 1/4 full interrupts are generated by the IB FIFO. Processing of the interrupts is detailed in paragraph 3.2.

3.5 PROGRAMMING GUIDELINES

The Supervisor software is written in RP-16 Assembly language and assembled using the RP-16 Relocatable Assembler (RAMA). The software is loaded into the Supervisor RAM by the SC which loads a loading routine into the common 1K RAM, Initializes the New Starts the Supervisor Micro-Processor, and transfers the object text records to the loading routine via the 1K RAM.

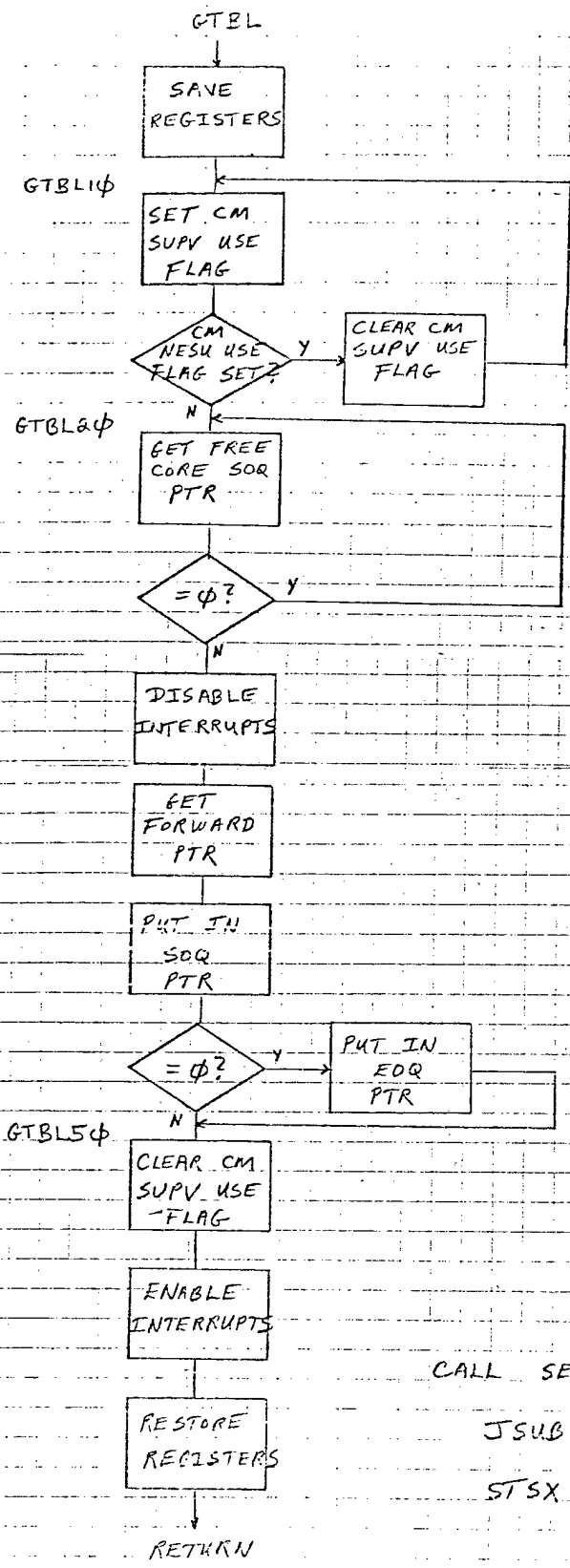

CM MEANS 'CORE MANAGER'

SUPPLY OF CORE BLOCKS EXHAUSTED

CALL SEQ -
 JSUB (=GTBL)
 STSX (ADDR OF BLOCK)

RAYTHEON		RAYTHEON COMPANY	
		LEXINGTON, MASS 02173	
GET BLOCK SUBROUTINE			
49956	7	CHEMISTRY	17 JUN 56
NUMBER	2	SHEET	1 OF 1

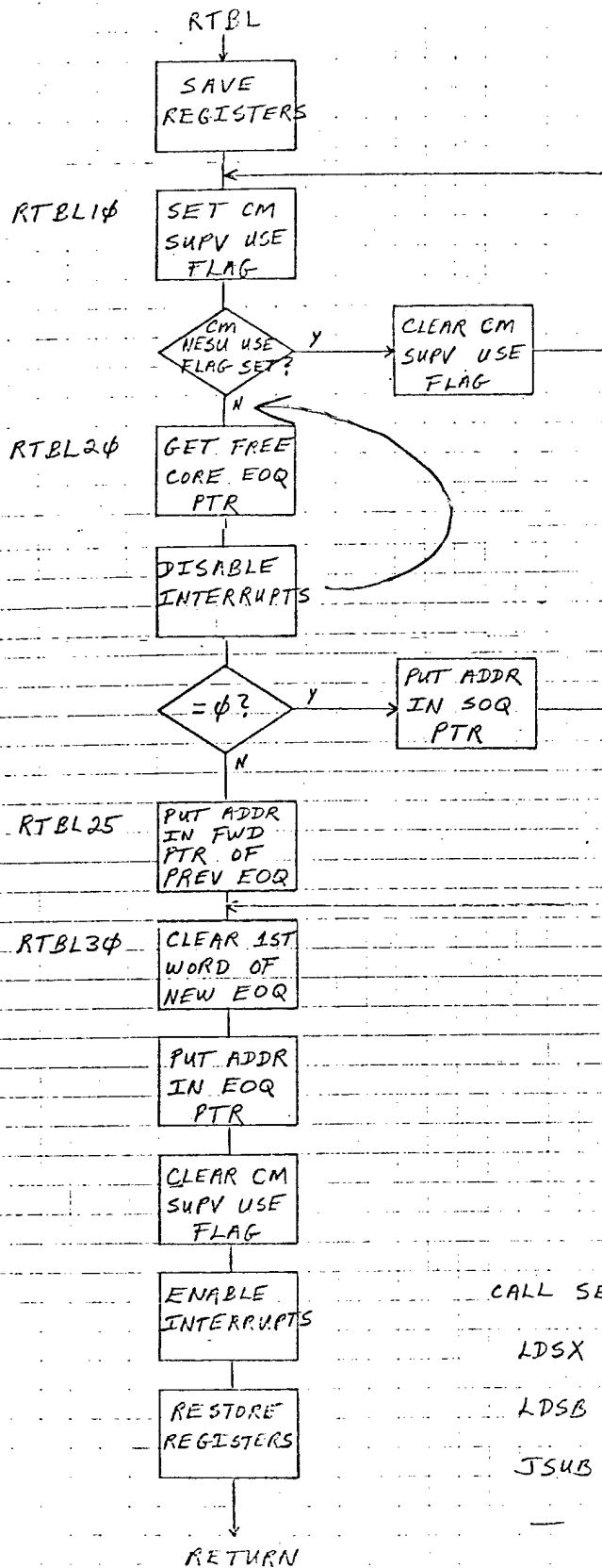

'CM' MEANS
'CORE MANAGER'

CALL SEQ -

LDSX (ADDR OF 1ST BLK RETURNED)

LDSB (ADDR OF LAST BLK RETURNED)

JSUB (=RTBL)

— NORMAL RETURN

RAYTHEON		RAYTHEON COMPANY	
		LEXINGTON, MASS 02173	
RETURN BLOCK SUBROUTINE			
49956	T. PHERNECKY	2/11/76	
NUMBER	3	SHEET	1 OF 1

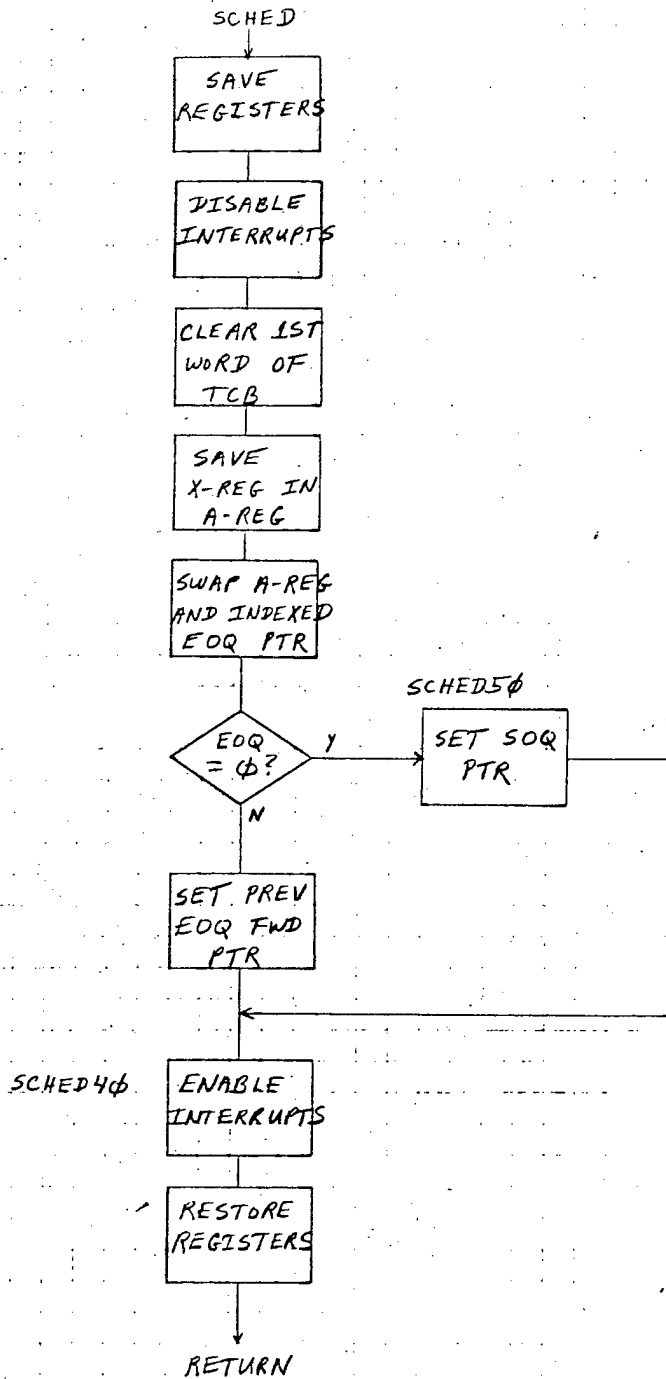

'TCB' MEANS 'TASK CONTROL BLOCK'

INDEXING IS BY TASK PRIORITY LEVEL

SCHED4φ

SCHED5φ

CALL SEQ -

LDSX (ADDR OF TCB)

LDSB (TASK PRIORITY LEVEL)

JSUB (=SCHED)

- NORMAL RETURN

		RAYTHEON COMPANY LEXINGTON, MASS 02173	
PROGRAM/ROUTINE/SUBROUTINE ACRONYM LEWS SORTER SUPV			
SCHEDULER SUBROUTINE			
CODE IDENT NO 49956	PREPARED BY T. CHERNESKY	DATE 9 APR 76	
NUMBER 4	SHEET 1 OF 1		

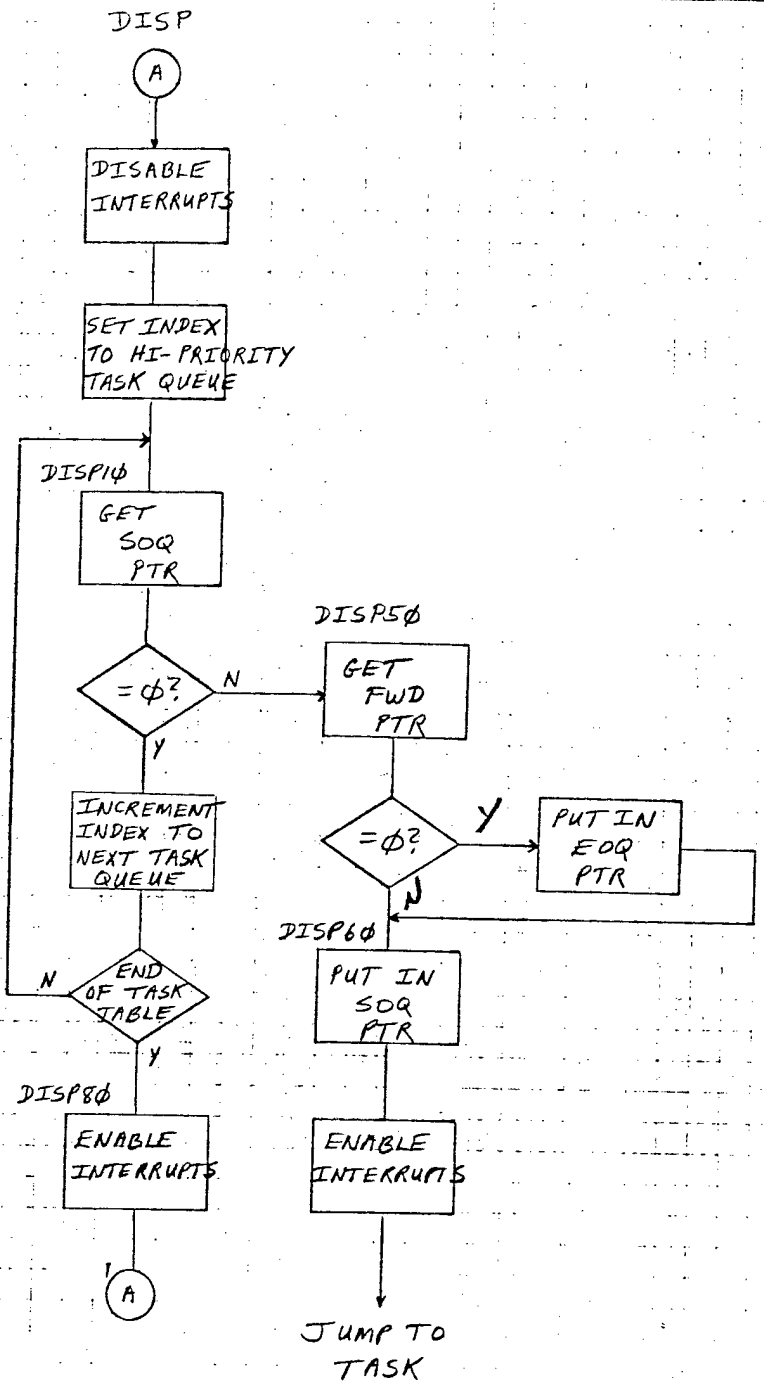

CALL SEQ -
 JUMP (=DISP)

X-REG CONTAINS
 ADDR OF TASK
 CONTROL BLOCK

RAYTHEON		RAYTHEON COMPANY LEXINGTON, MASS. 02173	
PROGRAM / ROUTINE / SUBROUTINE / ACRONYM		IEWS SORTER SUPV	
DISPATCHER			
CODE IDENT NO	PREPARED BY	DATE	
49956	T. CHERNESKY	9 APR 76	
NUMBER	5 SHEET 1 OF 1		

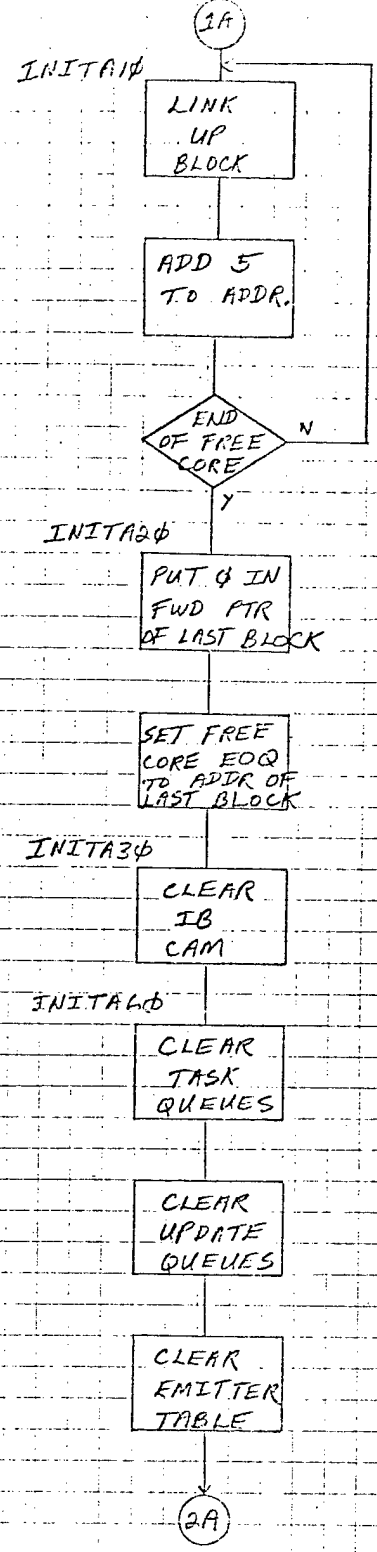
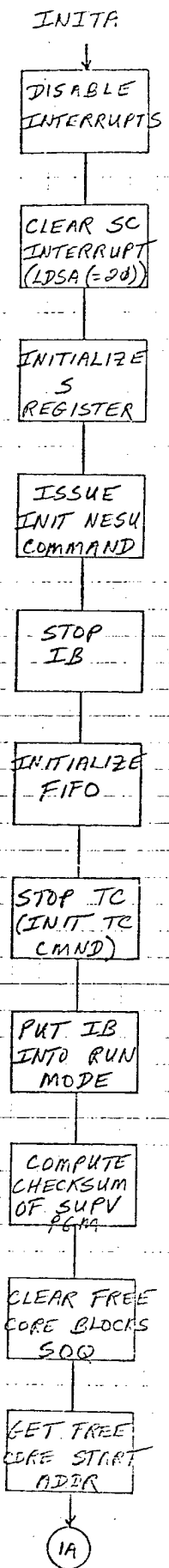

RAYTHEON		RAYTHEON COMPANY	
		LEXINGTON, MASS. 02173	
INITIALIZATION MODULE			
49956	CHERNICK	ISSN 71	
PAGE 1		OF 2	

2A

2B

CLEAR UPDATE COUNT

INIT. TC

CLEAR SYSTEM TIME

PUT TC INTO RUN MODE

INITA4φ

INIT. EMITTER TABLE

ENABLE BPDW PROCESSING

INITA45

CLEAR MSG BUFFER FLAG WORDS

RESET WATCHDOG TIMER

INITA8φ

CLEAR CORE MGR IN USE BY NESU FLAG

ENABLE 8 INTERRUPTS IN TC

INITA5φ

INIT. THROTTLE TABLE

INITA9φ

INIT 128 TRACK FILES IN TDM

INITA65

INIT. 8 INTERRUPT TRAP ADDR.

STORE φ IN PIN MASK REG.

SET RTC INTERRUPT CTR TO -4

ENABLE HI INTERRUPTS

PUT ADDR OF NESU INIT. IN NESU LOC. φ

ENABLE LO INTERRUPTS

ISSUE NEWSTART NESU

LOAD WEIGHT THRESHOLD

SCHEDULE MSG POLLING TASK

DISPATCHER

2B

RAYTHEON	RAYTHEON COMPANY LEXINGTON, MASS 02173
INITIALIZATION ROUTINE	
49956	T. CARRIS
7 JUN 68	

SAVE
REGISTERS

MASK INTERRUPT
LEVELS 5 → 1
(PIN MASK REG ← 6)

ENABLE
LO
INTERRUPTS

IS
SUPV IDLE
FLAG SET?

INCREMENT
SYSTEM
TIME

NEG?

SET
SYSTEM
TIME = 0

SET NESU
PURGE
FLAG

GET BLOCK
FROM FREE
CORE

SCHED
TIME-OUT
CK TASK

INCREMENT
RTC INTERRUPT
COUNT

= 0?

SRTC90
ENABLE IB
3/4 FULL
INTERRUPT
VIA TC

SRTC95
UNMASK
INTERRUPTS
(IN MASK REG ← 0)

SCHED
INITIATE
UPDATE

RESTORE
REGISTERS

SET RTC
INTERRUPT
COUNT = 1

INTERRUPT
RETURN

RAYTHEON		RAYTHEON COMPANY	
		LEYINGTON, MASS 02173	
49956		T. G. HANSEN	
DATE		PAGE 1 OF 1	

SHUNGRUP

SAVE REGS
IN 1K
RAM

SEND BUS
HUNG ERROR
MSG TO SC

HALT

SWD RFT

SAVE REGS
IN 1K
RAM

COMPUTE
CHECKSUM
OF SUPV
PROGRAM

=
INITIALIZED
VALUE?

SEND ERROR
ALERT MSG
TO SC

RESET
WATCHDOG
TIMER

RESTORE
REGISTERS

ENABLE
LO
INTERRUPTS

INTERRUPT
RETURN

SEND WD
TIMER EXP
MSG TO SC

HALT

SPANRUPT

SAVE REGS
IN 1K
RAM

HALT

REGS. SAVED
ARE A,E,B,X,S,P

RAYTHEON		RAYTHEON COMPANY	
		LEXINGTON, MASS. 02173	
PROGRAM TITLE: BUS HUNG ERROR		DATE: 09 MAY 76	
49956		T. CHESTNUT	
PAGE 1		OF 1	

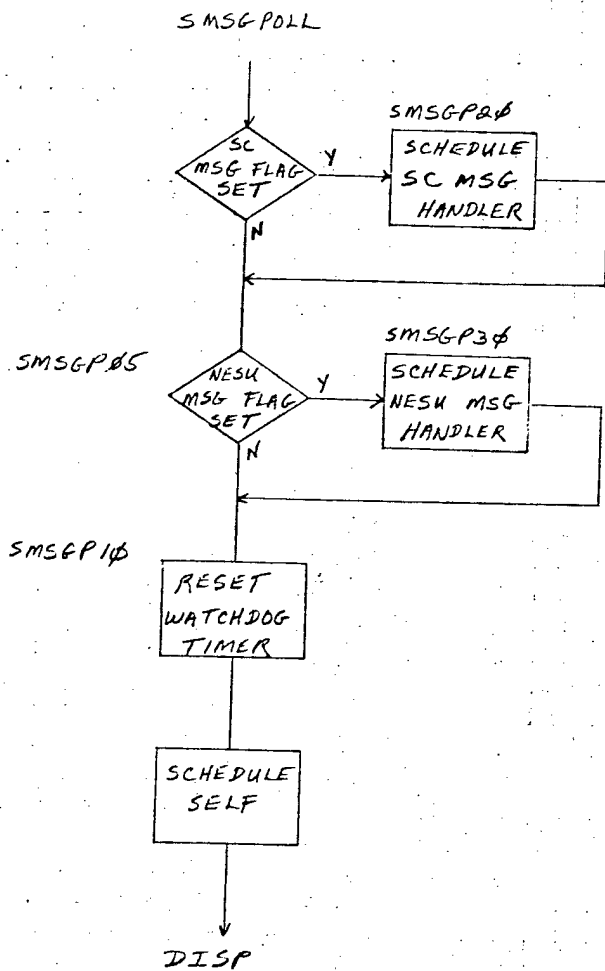

RAYTHEON		RAYTHEON COMPANY LEXINGTON, MASS. 02173	
PROGRAM/ROUTINE/SUBROUTINE/ACRONYM IEWS SORTER SUPV			
MESSAGE POLLING TASK			
CODE IDENT NO 49956	PREPARED BY T. CHERNESKY	DATE 12 APR 76	
N.WBER 23	SHEET 1 OF 1		

IB34RUPT

IB14RUPT

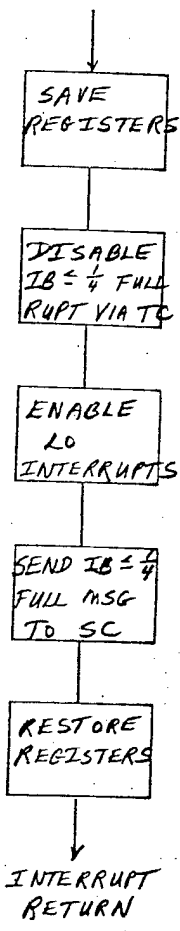
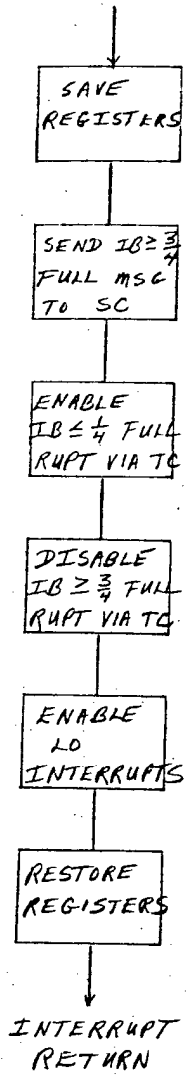

IB ≥ 3/4 FULL INTERRUPT IS ENABLED VIA TC EVERY RTC INTERRUPT

RAYTHEON		RAYTHEON COMPANY LEXINGTON, MASS. 02173	
PROGRAM/ROUTINE/SUBROUTINE/ACRONYM: IEWS SCATER SUPV			
IB INTERRUPT HANDLERS			
CODE IDENT NO. 49956	PREPARED BY T. CHERNESKY	DATE 30 APR 76	
NUMBER 24	SHEET 1 OF 1		

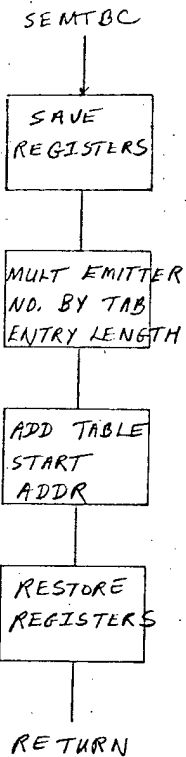

CALL SEQ -

LDSA (EMITTER NO.)

JSUB (= SEMTBC)

STSA (EMTB ENTRY ADDR.)

RAYTHEON		RAYTHEON COMPANY LEXINGTON, MASS. 02173	
PROGRAM / ROUTINE / SUBROUTINE / ACRONYM IEWS SCRTK SUPV			
CALC. EMITTER TABLE ENTRY ADDR SUBR.			
CODE IDENT. NO.	PREPARED BY	DATE	
49956	T. CHERNESKY	30 APR 76	
NUMBER	25	SHEET 1 OF 1	

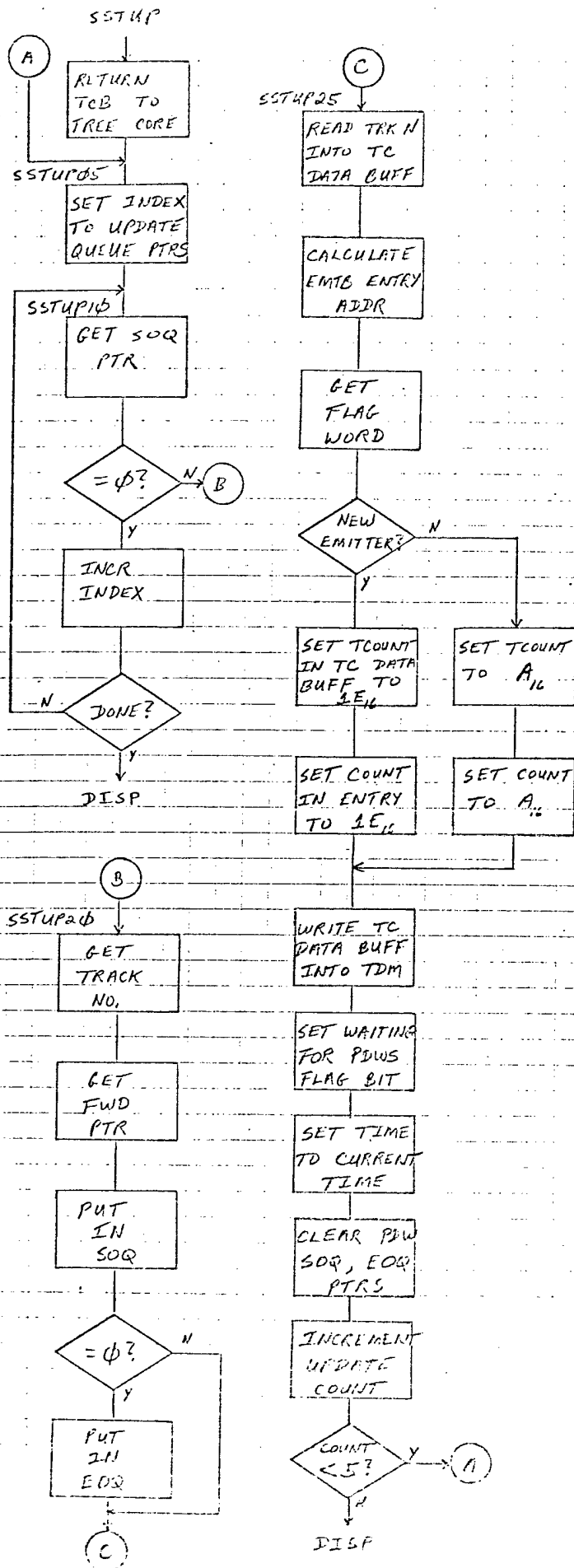

RAYTHEON		RAYTHEON COMPANY	
		LEXINGTON, MASS 02173	
START UPDATE TASK			
49955	T. CHENNEY	7 JUN 76	
		7 ISSUES 1 OF 1	

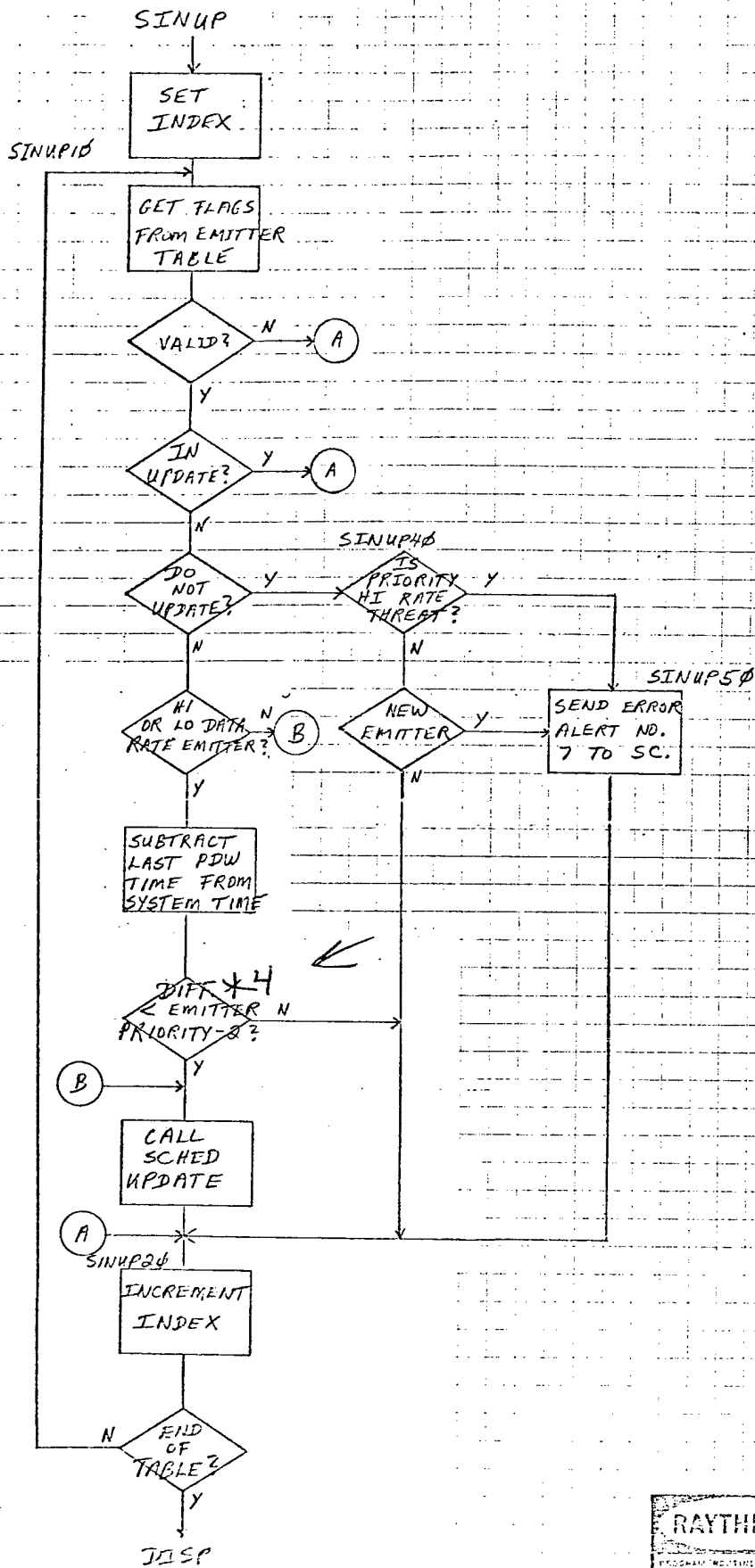

EMITTER UPDATE INTERVALS

- 1 SEC
 - NEW EMITTER
 - HI RATE THREAT
- 2 SEC
 - HI RATE
- 4 SEC
 - LO RATE

RAYTHEON		RAYTHEON COMPANY LEXINGTON, MASS. 02173	
PROGRAM INCLUDES TO INDICATE AGENCY IIDS SYSTEM DATA INITIATE UPDATE TASK			
49956	T. W. HENNESSY	1 JUN 76	
PAGE 7		SHEET 1 OF 1	

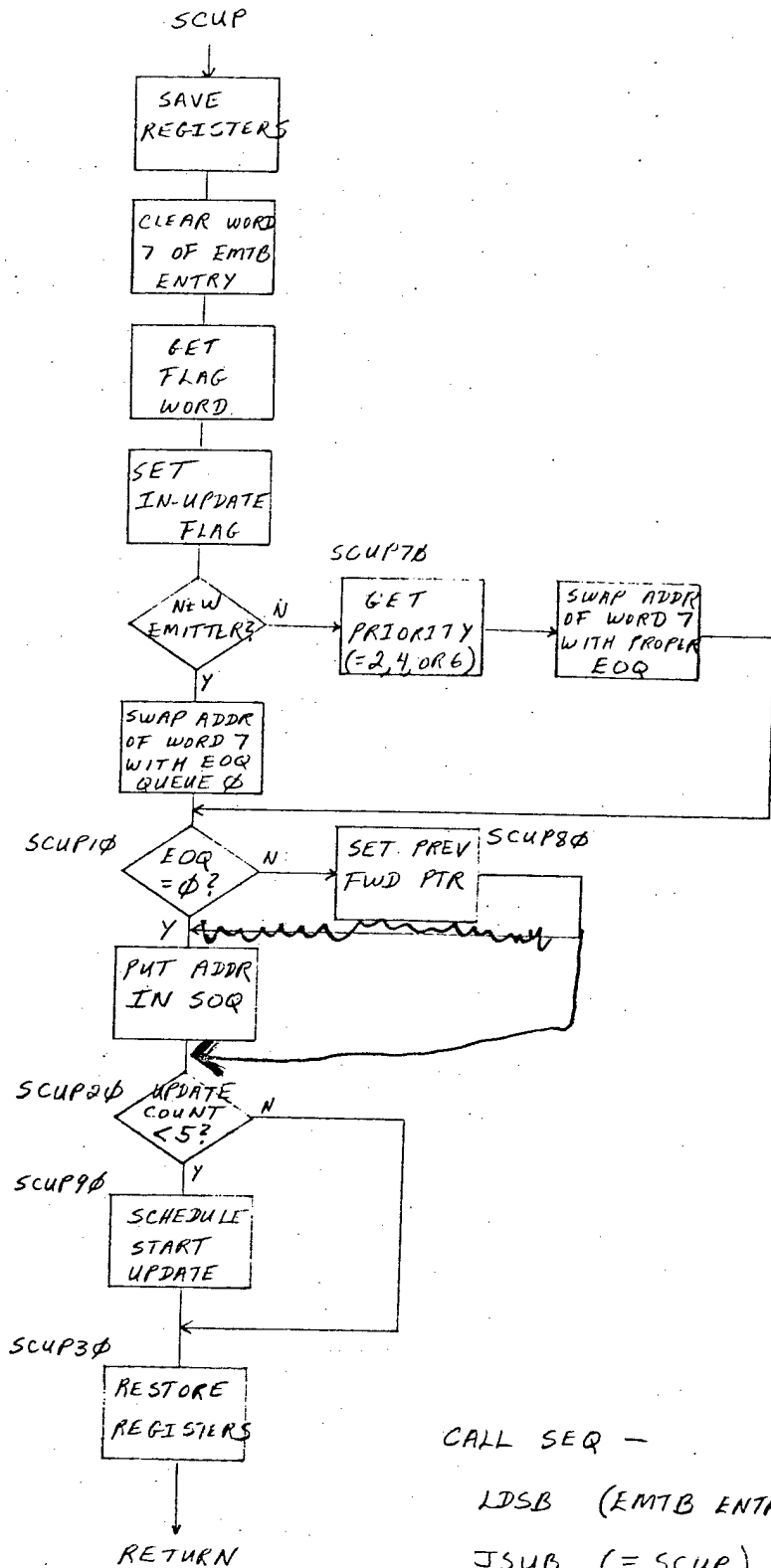

'EMTB' MEANS
'SUPV EMTB TABLE'

CALL SEQ -
LDSB (EMTB ENTRY ADDR)
JSUB (= SCUP)
- NORMAL RETURN

RAYTHEON		RAYTHEON COMPANY LEXINGTON, MASS. 02173	
PROGRAM/ROUTINE/SUBROUTINE/ACRONYM IEWS SORTER SUPV			
SCHEDULE UPDATE SUBROUTINE			
CODE IDENT NO 49956	PREPARED BY T. CHERNESKY	DATE 12 APR 76	
SHEET 1 OF 1		10	

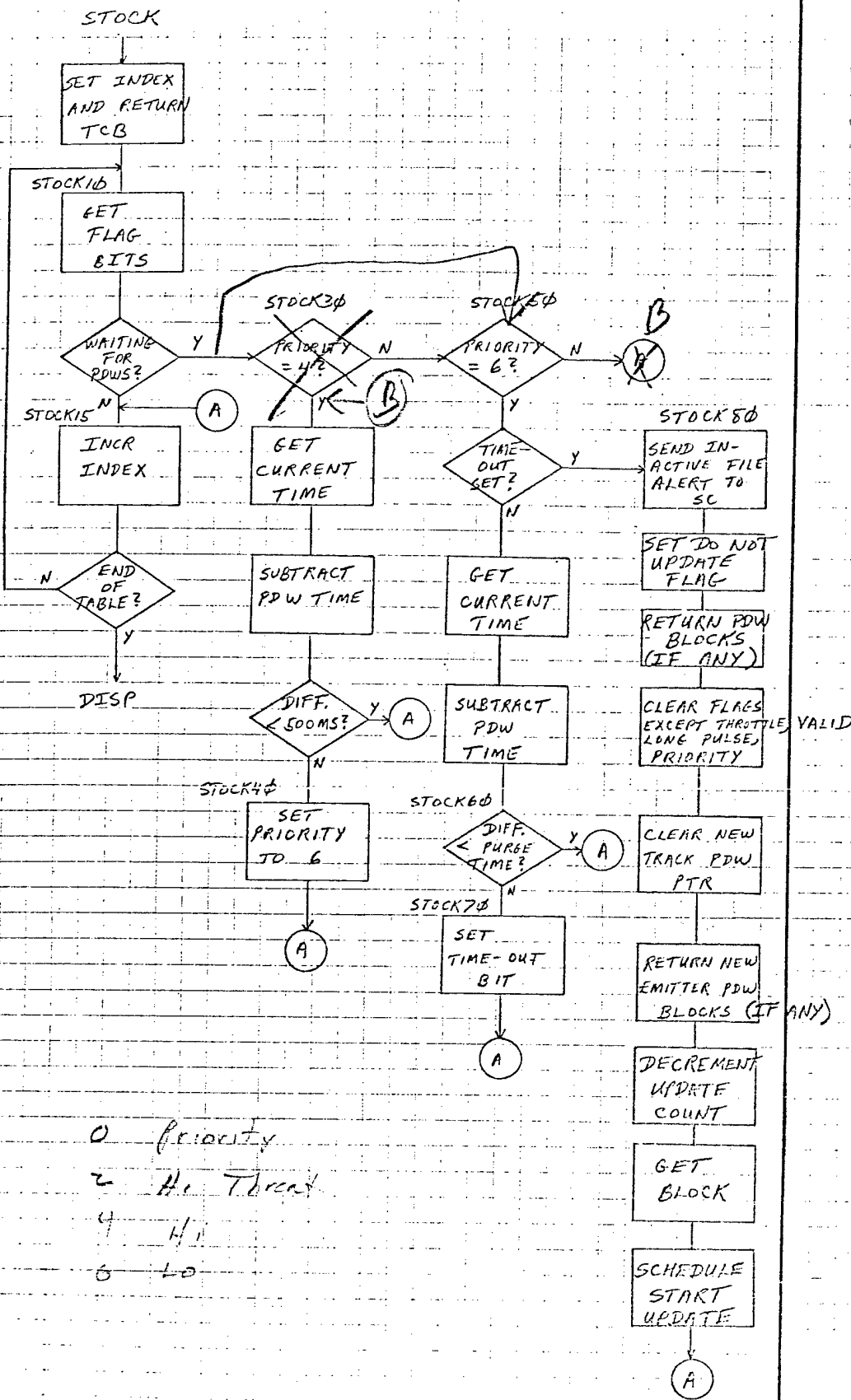

0 Priority
 2 Hi Thread
 4 Hi
 6 Lo

RAYTHEON		RAYTHEON COMPANY	
		LEXINGTON, MASS. 02173	
DATE: 11/10/76			
TIME: 11:00 AM			
BY: T. CHERNOBYL			
CHECKED: J. SUN			
49956		11/10/76	
		11/10/76	

AZIMUTH
CALCULATION

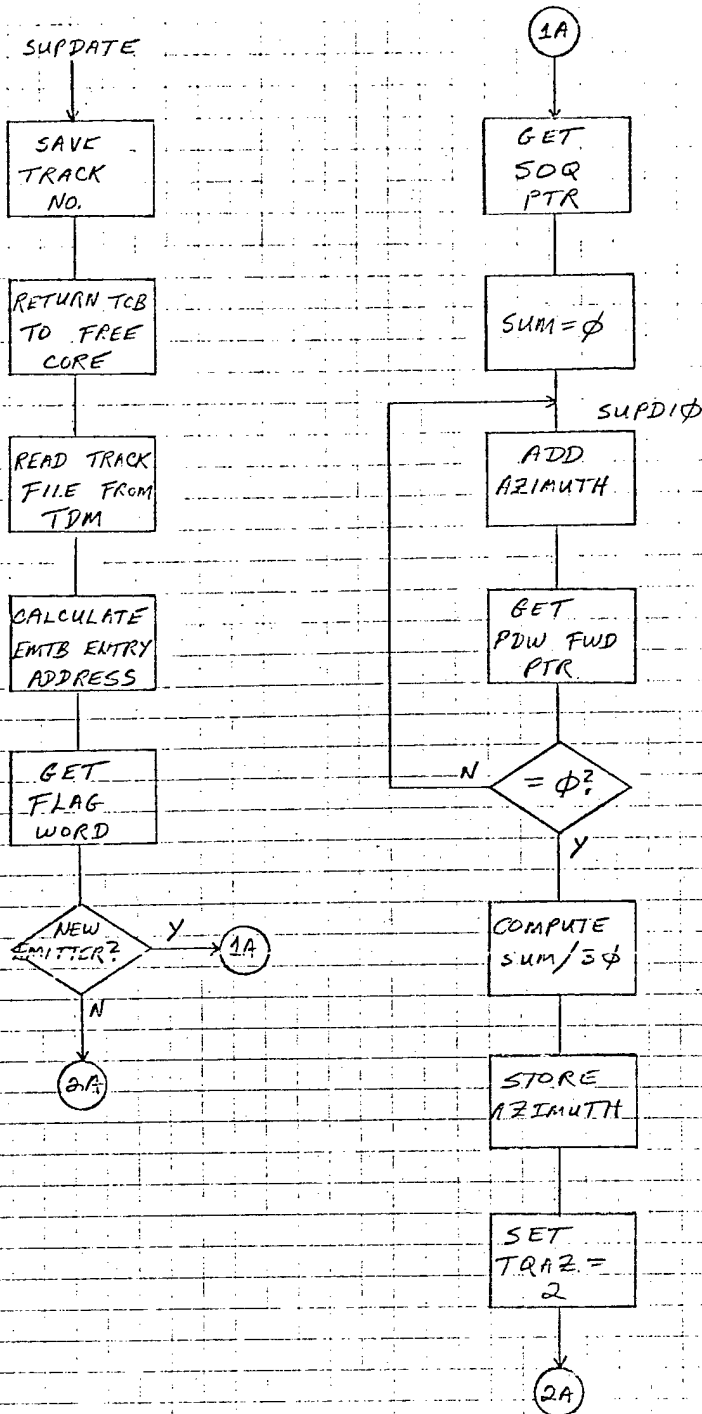

RAYTHEON	RAYTHEON COMPANY
	LEXINGTON MASS 02173
PROGRAM ENGINEERING DIVISION	
UPDATE 7/76	
49956	3 JUN 76
PAGE 1 OF 9	

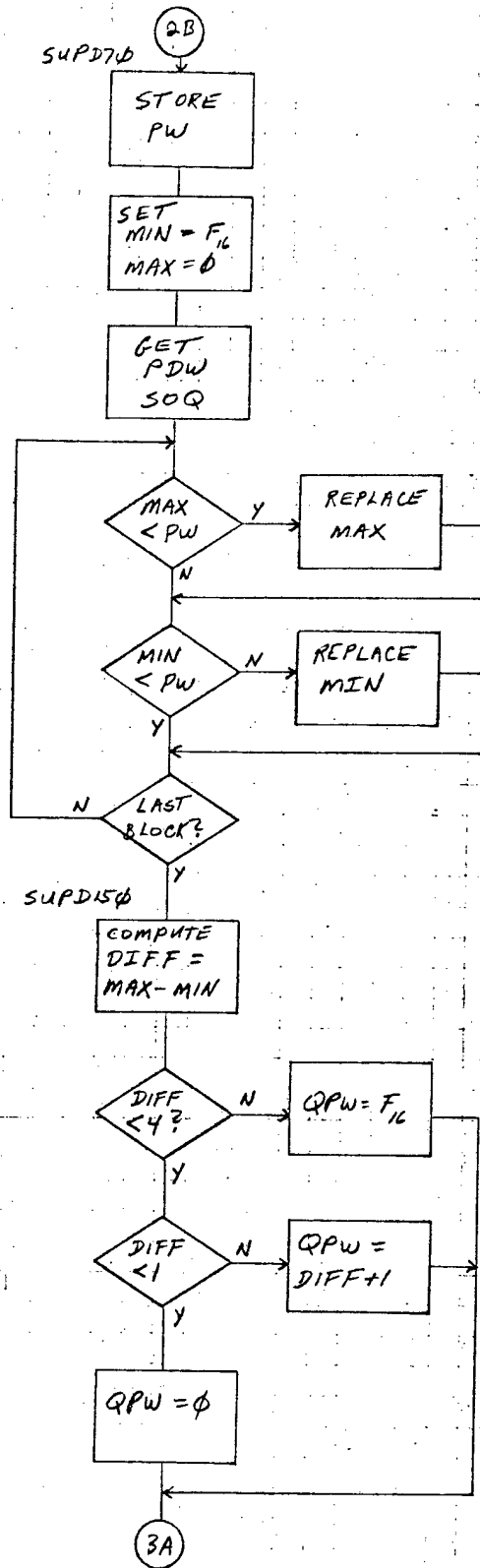
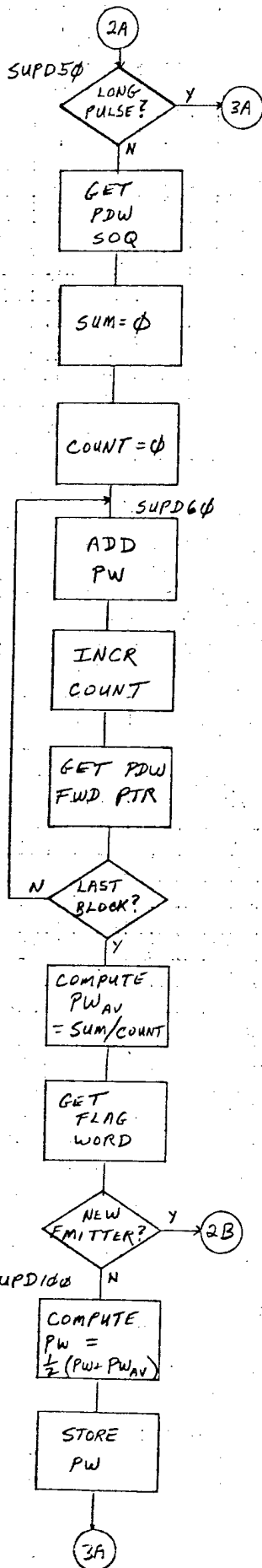

PULSE WIDTH CALCULATION

RAYTHEON		RAYTHEON COMPANY LEXINGTON, MASS 02173	
PROGRAM/ROUTINE/SUBROUTINE/ACRONYM IEWS SORTER SUPV			
UPDATE TASK			
CODE IDENT NO 49956	PREPARED BY T. CHERNESKY	DATE 5 MAY 76	
NUMBER 13	SHEET 2 OF 9		

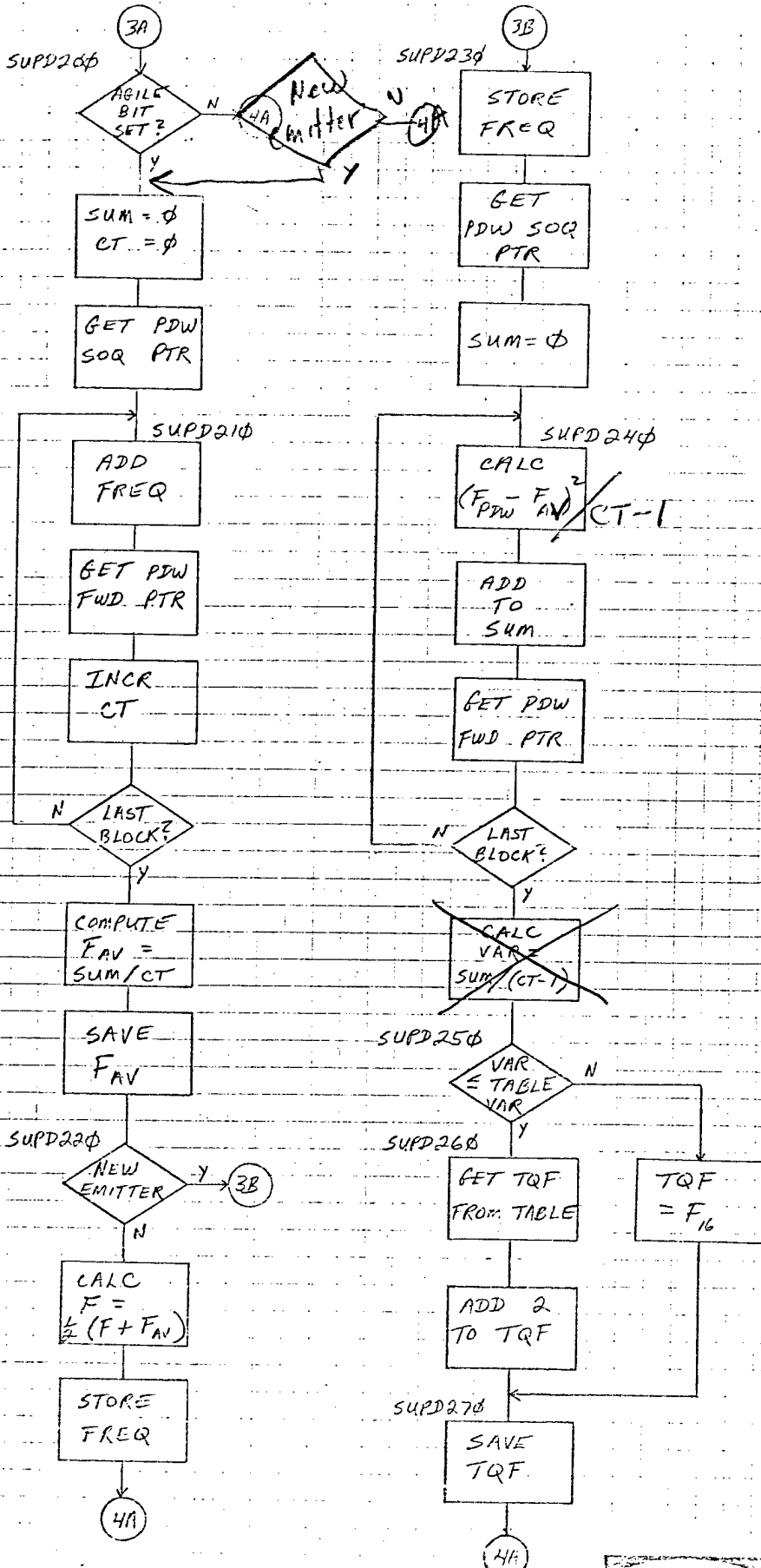

FREQUENCY CALCULATION

Calculation of one term of the variance estimate.

RAYTHEON		RAYTHEON COMPANY	
		LEXINGTON, MASS 02173	
PROGRAM INITIAL		PROGRAM NAME	
UPDATE TASK		LEWS BORTER SUPV	
49956	7	DATE	7-14-71
FORM 100	100	ISSUED	CT 7

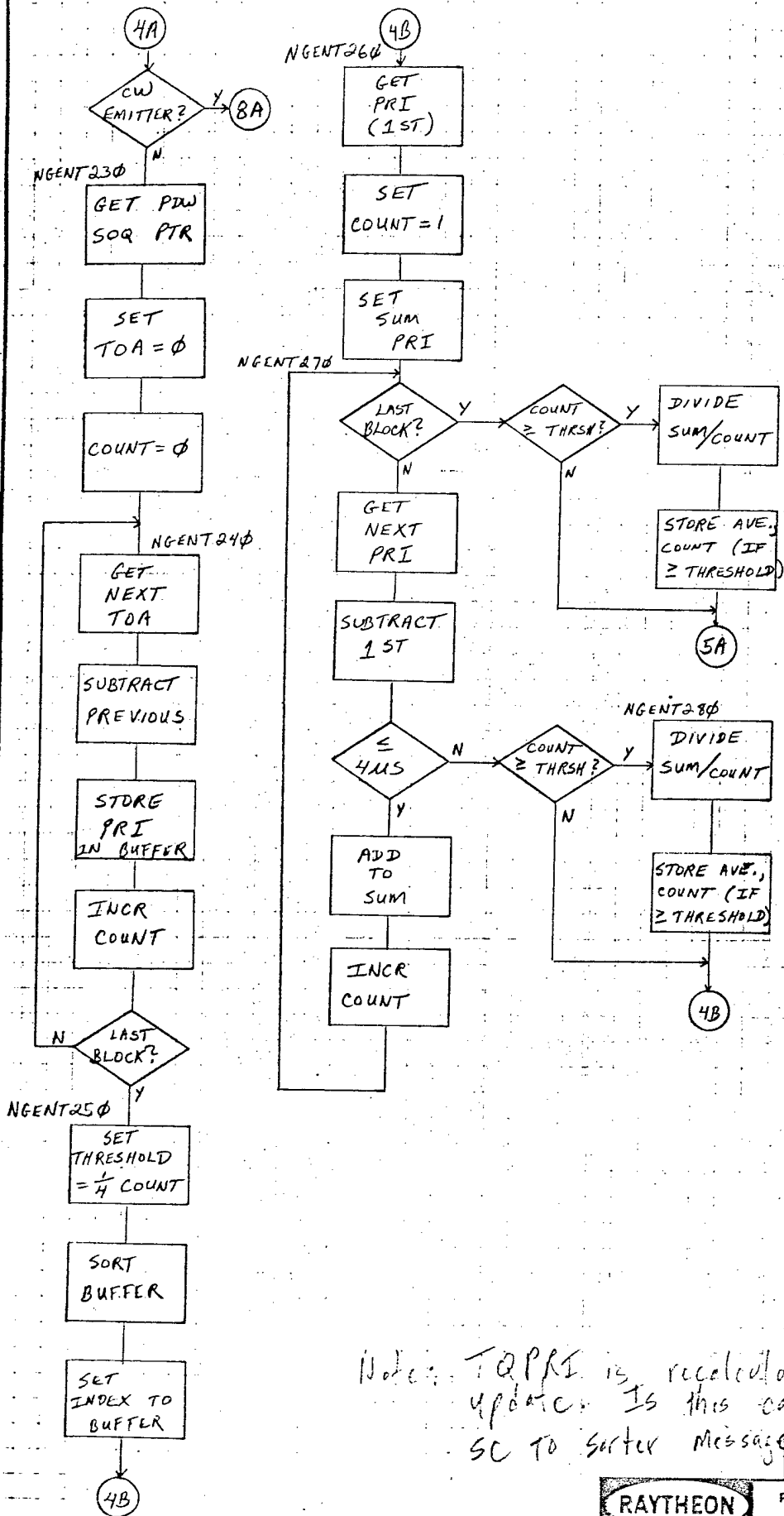

PRI CALCULATION.
 Find no. of groups of PRI within 4ms and count in group \geq threshold

Note: TQPRI is recalculated every update. Is this consistent with SC to sorter message? No, set TQPRI only if new emitter

RAYTHEON		RAYTHEON COMPANY LEXINGTON, MASS. 02173	
PROGRAM/ROUTINE/SUBROUTINE/ACRONYM		JEWS SORTER SUPV	
UPDATE TASK			
CODE IDENT NO	PREPARED BY	DATE	
49956	T. CHERNESKY	5 MAY 76	
NUMBER	15	SHEET 4 OF 9	

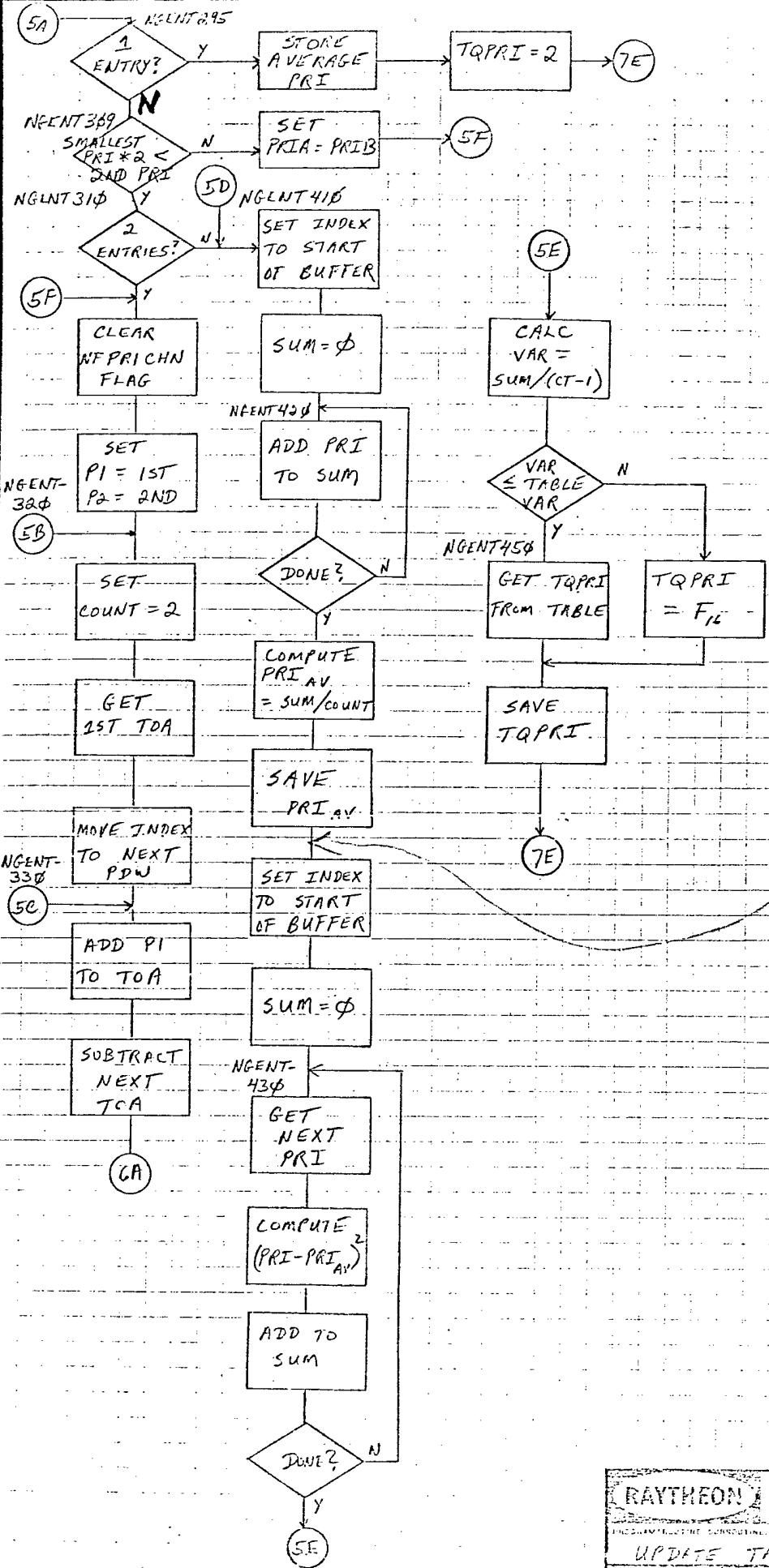

PRI.
CALCULATION

CHAINING
AND
VARIANCE
CALCULATION

*should skip
variance
calc
if not
new priority*

RAYTHEON		RAYTHEON COMPANY LEXINGTON, MASS 02173	
PROJECT: THE SCHEDULED BY ILWS SGT/IC SUIV			
UPDATE TASK			
NO. 49956	DATE T. P. KENNEDY	DATE 3 JUN 76	
NUMBER	SHEET 5 OF 9		

PRI CHAIN
CALCULATION -
TOA WRAPAROUND
PROBLEM

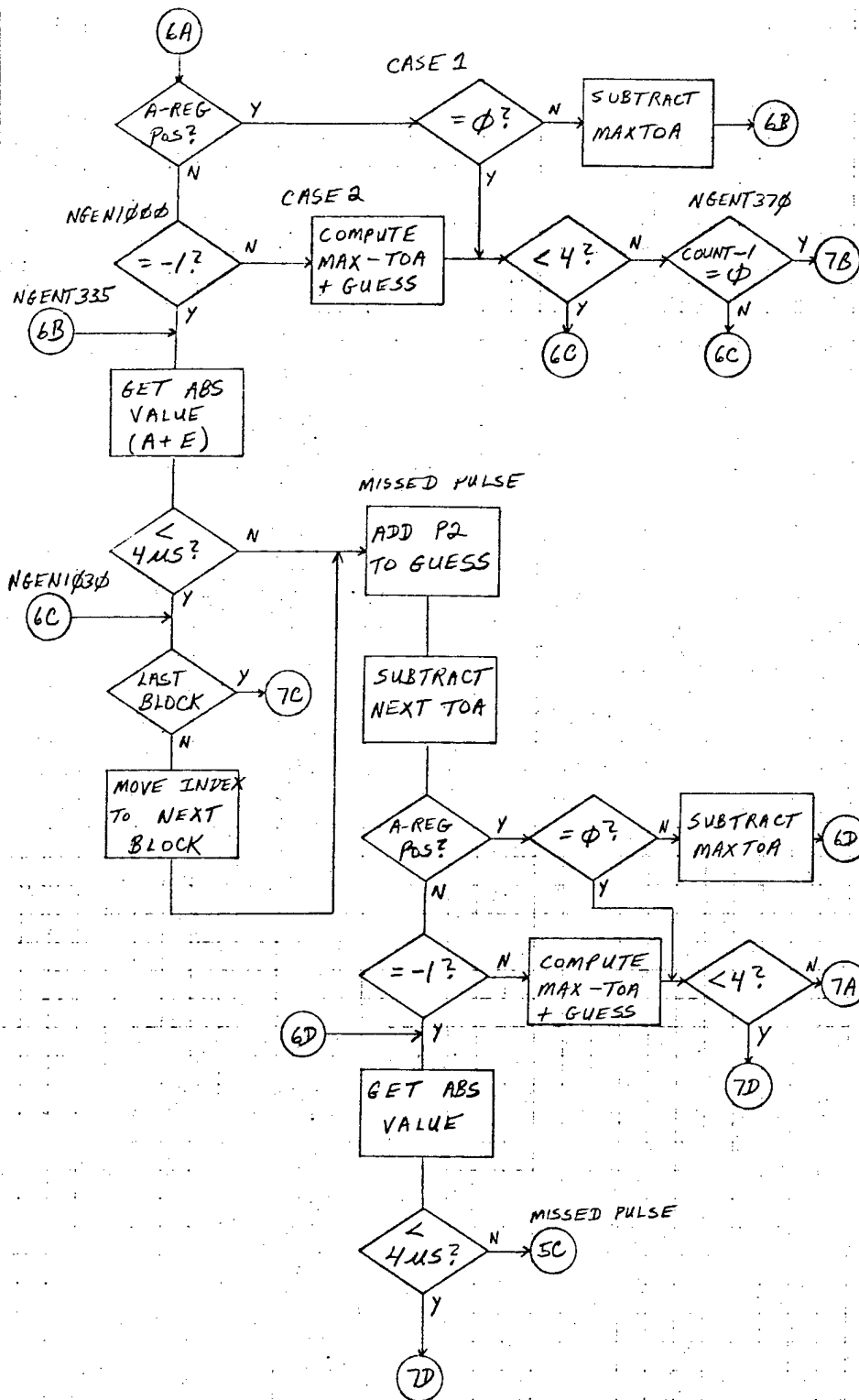

CASE 1 : GUESS = MAX - N N = 0, 1, 2, 3
 ACTUAL = M M = 3, 2, 1, 0

GUESS - ACTUAL = LARGE POS NO., I.E., MAX - N - M > 2¹⁶
 THEREFORE, NEED N + M < 4, ELSE POSSIBLE MISSED PULSE.
 IF A-REG POS AND NON-ZERO, THEN COMP ((GUESS - ACT) - MAX) = N + M

CASE 2 : GUESS = M M = 0, 1, 2, 3
 ACTUAL = MAX - N N = 3, 2, 1, 0
 GUESS - ACTUAL = LARGE NEG. NO., M - MAX - N
 THEREFORE, N + M < 4, ELSE ERROR.
 IF A-REG POS AND A ≠ -1 THEN
 MAX - ACT + GUESS = MAX - (MAX - N) + M = N + M

RAYTHEON		RAYTHEON COMPANY LEXINGTON, MASS. 02173	
PROGRAM/ROUTINE/SUBROUTINE/ACRONYM		IEWS SORTER SUPV	
UPDATE TASK			
CODE IDENT NO	PREPARED BY	DATE	
49956	T. CHERNESKY	7 MAY 76	
NUMBER	17	SHEET 6 OF 9	

PRI CHAIN
CALCULATION

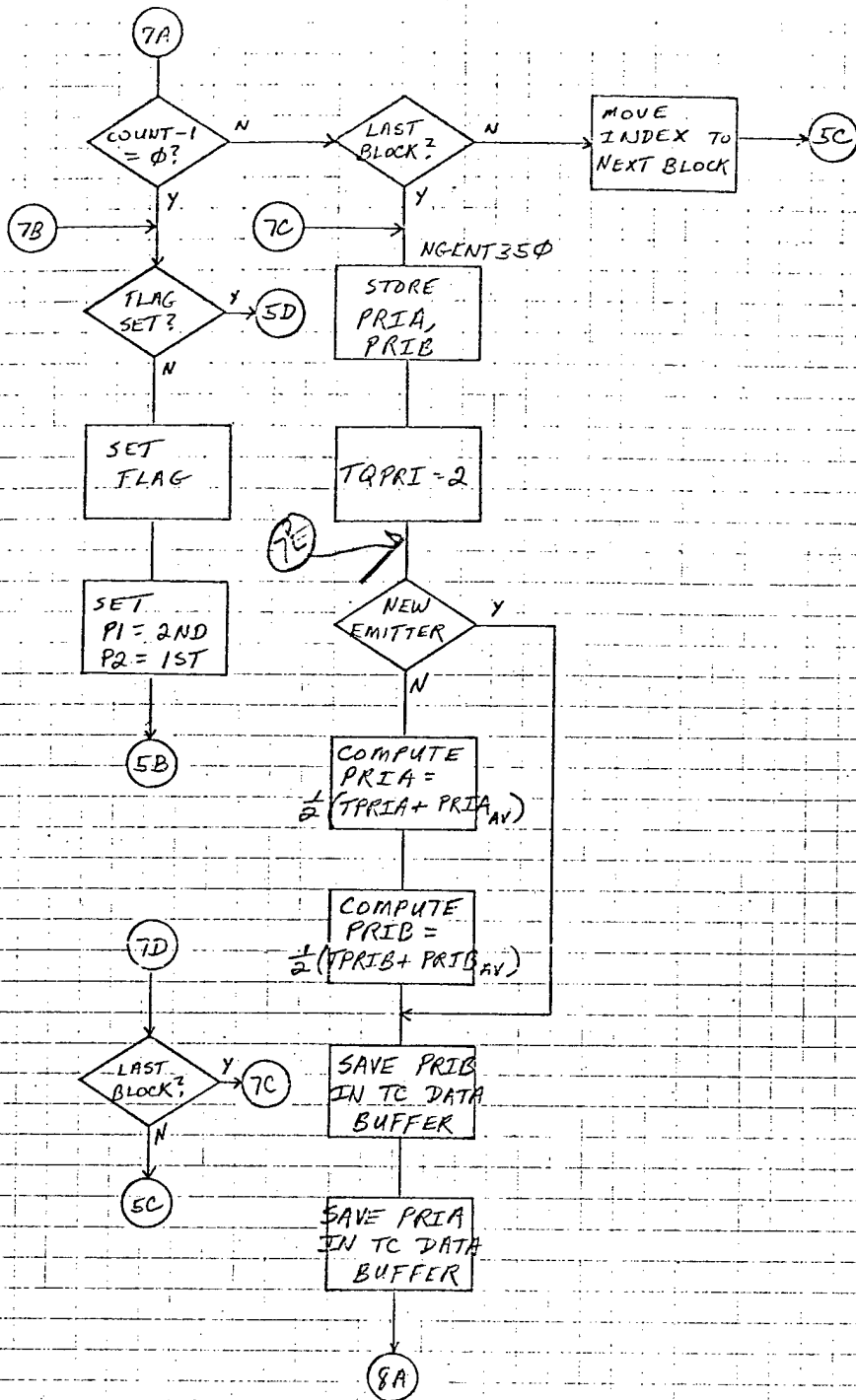

RAYTHEON		RAYTHEON COMPANY	
		LEXINGTON, MASS 02173	
PROGRAM & ACTING SUPERVISOR		JEWIS DOOTLER SUPV	
UPDATE TASK			
49956	T. CHEANESKY	3 JUN 76	
NUMBER	18	SHEET	7 OF 9

WRITE TRACK
FILE AND
OUTPUT MESSAGES
TO SC

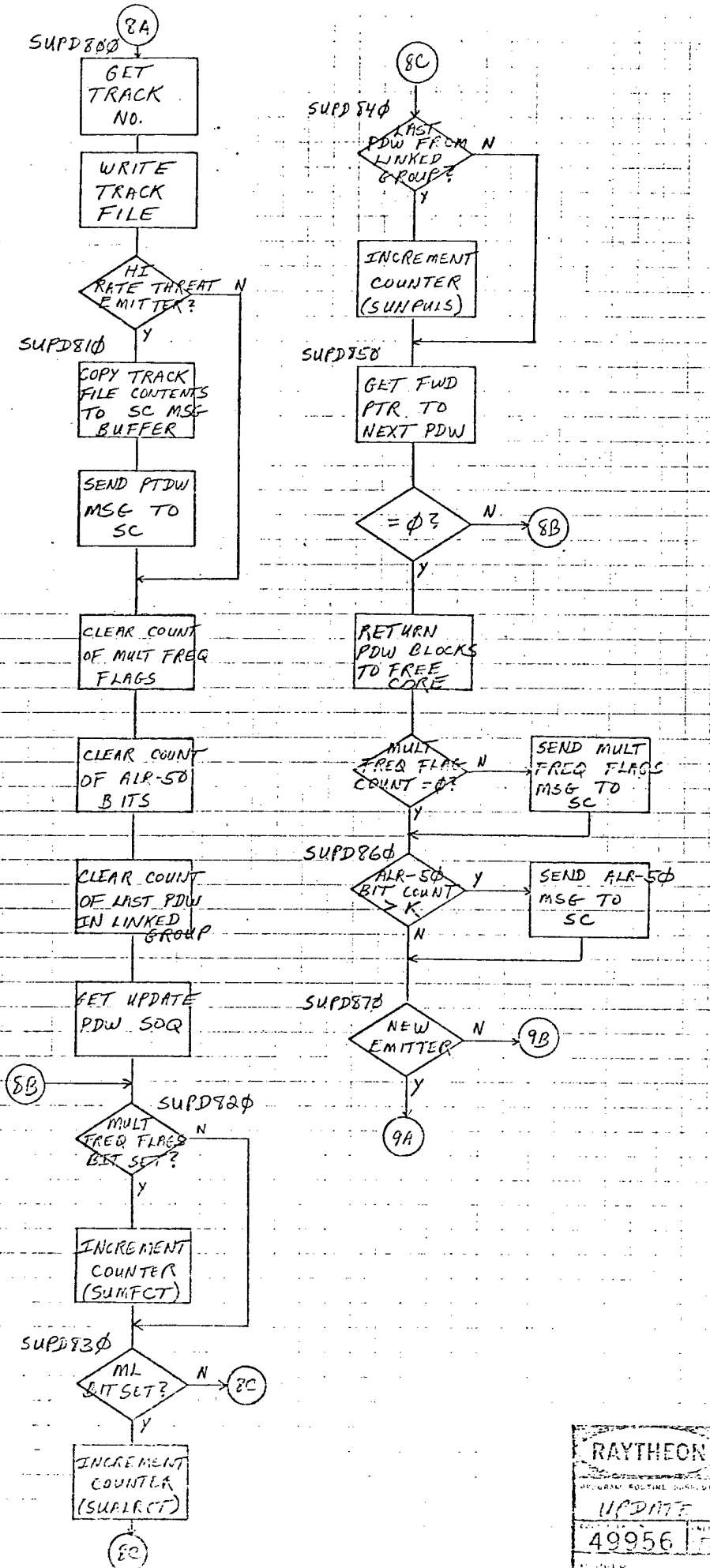

RAYTHEON		RAYTHEON COMPANY	
		LEXINGTON MASS 02173	
PROGRAM ROUTINE SUBROUTINE PROGRAM		JEWEL SORTER SUBV	
UPDATE TASK			
49956	DATE	3 JUN 76	
19	SHEET		OF 3

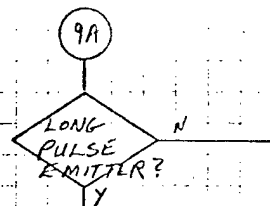

COMPUTE AVE NO. OF PDWS PER PULSE

GET PRIA AND PRIB CALC'D BY NESU

SEND LONG PULSE PARAM MSG TO SC

GET SOQ TO NEW EMITTER PDWS

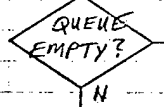

FIND END OF NEW EMITTER PDWS

RETURN NEW EMITTER PDWS TO FREE CORE

9B

CLEAR EMTB FLAGS

DECREMENT UPDATE COUNT

SCHEDULE START UPDATE

EXIT TO DISPATCHER

WRITE TRACK FILE AND OUTPUT MESSAGES TO SC

- FLAGS CLEARED :
1. IN UPDATE
 2. WAITING FOR PDWS
 3. TIME OUT
 4. NEW EMITTER

RAYTHEON		RAYTHEON COMPANY	
		LEXINGTON, MASS. 02173	
PROGRAM TITLE: IJUS DORTER SUPV			
UPDATE TASK			
NO. 49956	BY T. CHERNISKY	DATE 3 JUN 76	
NO. 20	SHEET 9 OF 9		

SSCRUPT

SAVE
REGISTERS

MASK INTERRUPTS
LEVELS 5 → 1
(PIN MASK REG. ← 6)

ENABLE
LD
INTERRUPTS

CLEAR SC
INTERRUPT
LDSA (=00)

GET
COMMAND
CODE

START
(01)

PAUSE
(02)

PAUSE
NESU
(1B)

INIT
AND START
NESU
(04)

INIT
(03)

SSCR100

SEND START
MSG TO
NESU

SSCR200

DISABLE
PE/STE PDW
PROCESSING

SSCR400

SEND INIT
MSG TO
NESU

INITIA
LIZER

CLEAR
IDLE
FLAG

SET
IDLE
FLAG

SEND START
MSG TO
NESU

SEND ERROR
ALERT NO. 1
TO SC

SSCR210

ENABLE
PE/STE PDW
PROCESSING

SEND
PAUSE MSG
TO NESU

SSCR35

CLEAR
SC MSG
FLAG

UNMASK
INTERRUPTS
(PIN MASK REG. ← 6)

RESTORE
REGISTERS

INTERRUPT
RETURN

RAYTHEON		RAYTHEON COMPANY	
		LEXINGTON, MASS 02173	
PROJECT NUMBER		49955	
DESIGNER		T. PHERNESKY	
DATE		2 JAN 74	
DRAWN		31	
SHEET		1 OF 1	

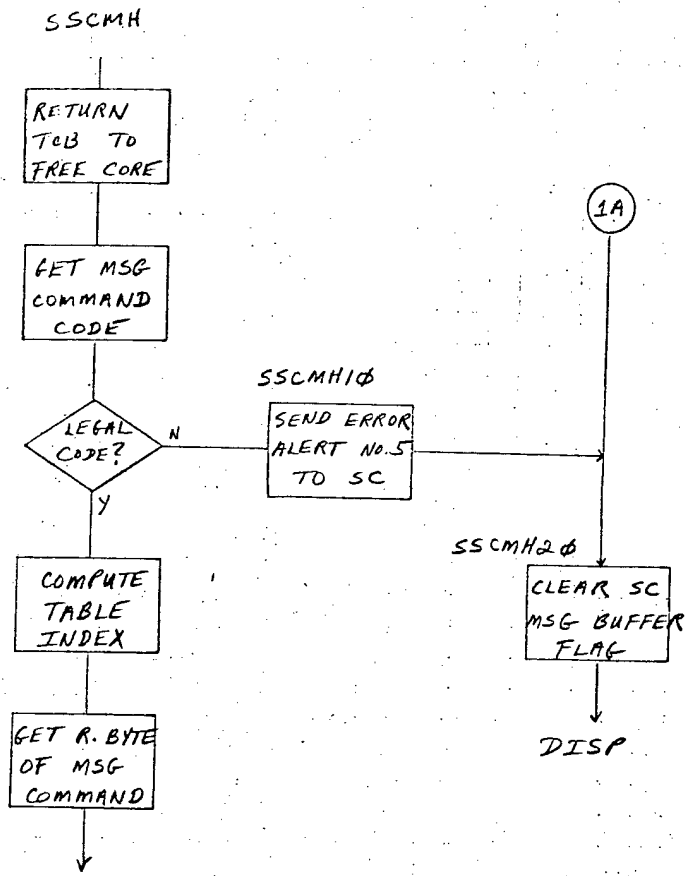

JUMP TO A LO-PRI MSG PROCESSING ROUTINE

CAM FILE DUMP
OP-CODE = 05

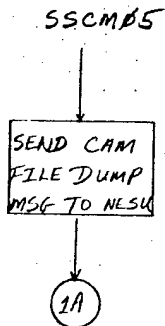

ADA READOUT REQUEST
OP-CODE = 06

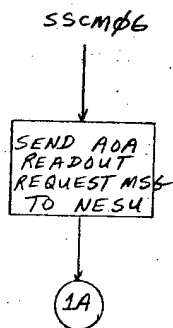

RIGHT BYTE
USUALLY CONTAINS
SORTER TRACK
FILE NO.

RAYTHEON		RAYTHEON COMPANY LEXINGTON, MASS. 02173	
PROGRAM/ROUTINE/SUBROUTINE/ACRONYM JEW'S SORTER SUPV SC MESSAGE HANDLING			
CODE IDENT NO 49956	PREPARED BY T. CHERNESKY	DATE 12 APR 76	
NUMBER 32		SHEET 1 OF 8	

FILL DUMP REQUEST
OP-CODE = 07
SSCM07

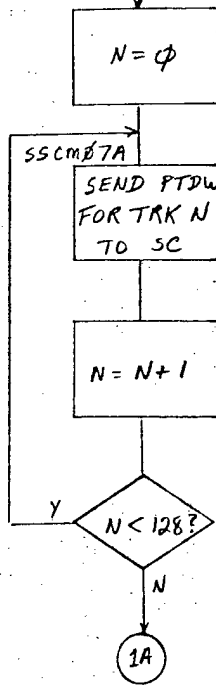

SYNTHETIC PDW
OP-CODE = 09
SSCM09

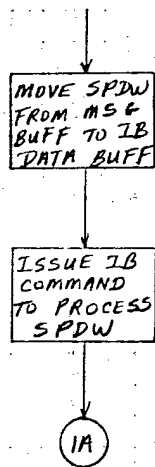

UPDW REQUEST
OP-CODE = 08
SSCM08

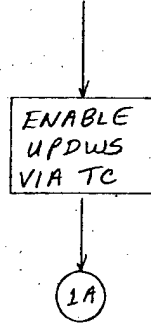

SUBROUTINE TO SEND 1 PTDW TO SC.
SSCMPTDW

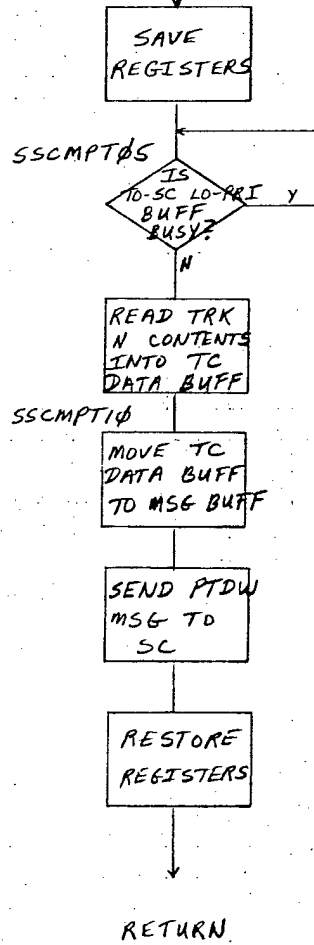

RAYTHEON		RAYTHEON COMPANY LEXINGTON, MASS. 02173	
PROGRAM / ROUTINE / SUBROUTINE / ACRONYM		LEWS SORTER SUPV	
SC MESSAGE HANDLING			
CODE IDENT. NO.	PREPARED BY	DATE	
49956	T. CHERNESKY	12 APR 76	
NUMBER	33	SHEET 2 OF 8	

NESU TRACK
 THRESHOLD MODIFY
 OP-CODE = ϕA
 SSCM ϕA

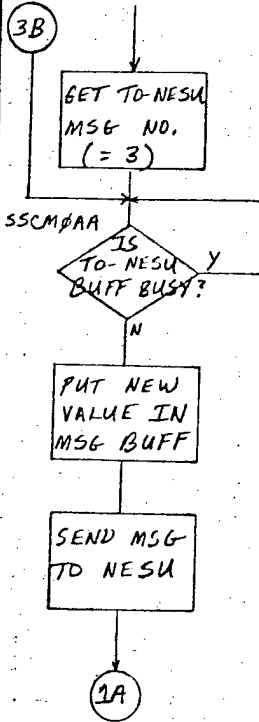

QUALITY BIT MOD.
 OF TRACK N
 OP-CODE = ϕB
 SSCM ϕB

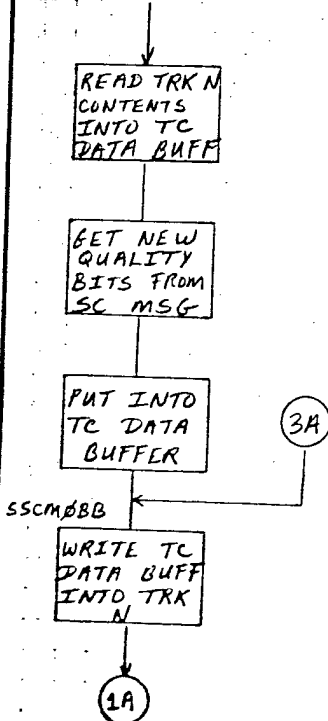

TRACK PRIORITY MOD.
 OP-CODE = ϕC
 SSCM ϕC

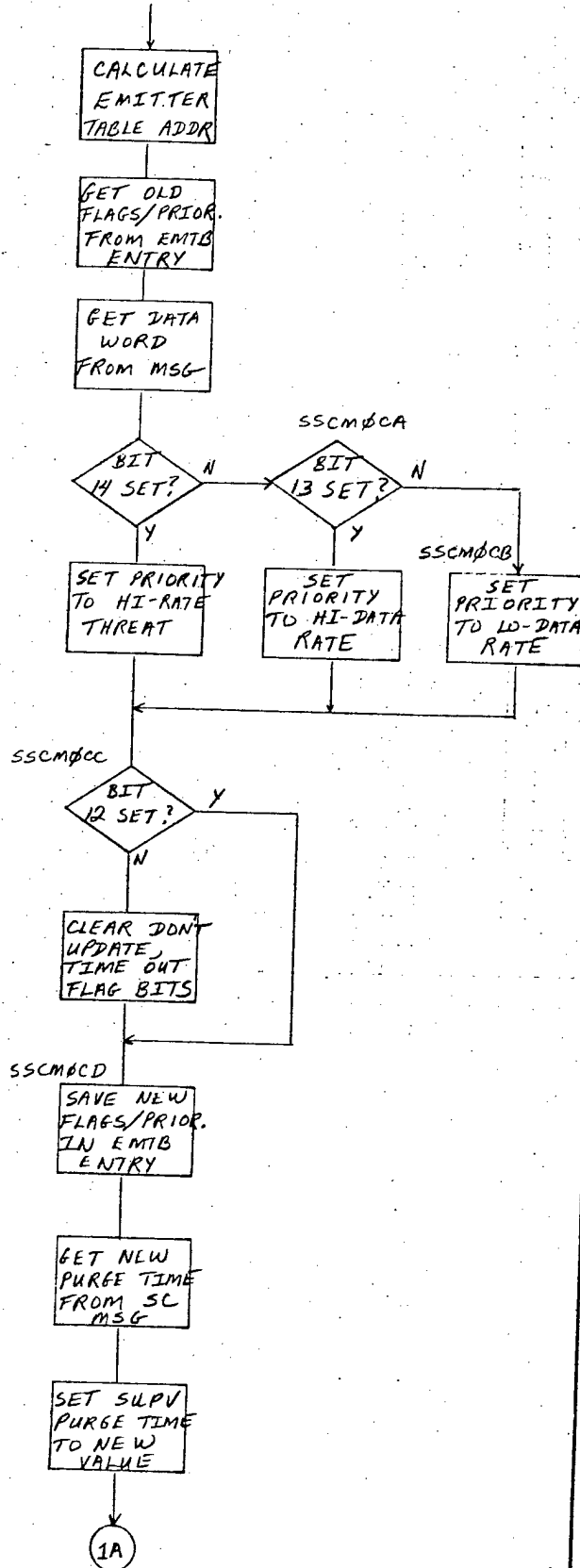

RAYTHEON		RAYTHEON COMPANY LEXINGTON, MASS 02173	
PROGRAM / ROUTINE / SUBROUTINE / ACRONYM IEWS SORTER SUPV			
SC MESSAGE HANDLING			
CODE IDENT NO 49956	PREPARED BY T. CHERNESKY	DATE 12 APR 76	
NUMBER	34	SHEET 3	OF 8

FLOW CHART

REMARKS

PTDW REQUEST
OP-CODE = ϕD
SSCM ϕD

SEND PTDW
FOR TRACK
N TO SC

1A

SPDW REQUEST
OP-CODE = ϕE
SSCM ϕE

READ TRKN
CONTENTS
INTO TC
DATA BUFF

GET TTAMP,
TCODE FROM
SC MSG

TRANSFORM
INTO TDM
FILE
FORMAT

PUT INTO
TC DATA
BUFFER

SET
THRSC IN
TC DATA
BUFFER

3A

SPDW STOP
OP-CODE = ϕF
SSCM ϕF

READ TRKN
CONTENTS
INTO TC
DATA BUFF

CLEAR
THRSC IN
TC DATA
BUFFER

3A

NEPDW REQUEST
OP-CODE = 1ϕ
SSCM 1ϕ

CALCULATE
EMTB ENTRY
ADDRESS

GET
NEPDWS
SOQ

$= \phi ?$

SSCM $1\phi D$

SEND ERR
ALERT NO.
2 TO SC

1A

GET A
NEPDW

SSCM $1\phi A$

IS
TO-SC 10-PRI
BUFF BUSY?

PUT PDW
IN MSG
BUFFER

GET PDW'S
FWD PTR

$= \phi ?$

SSCM $1\phi B$

SET LAST
NEPDW
MSG FLAG

SEND
NEPDW MSG
TO SC

RETURN THE
NEPDW
BLOCKS TO
FREE CORE

CLEAR SOQ
FOR NEPDWS
IN EMTB
ENTRY

1A

SEND
NEPDW MSG
TO SC

'NEPDW' MEANS
'NEW EMITTER
PDW'

RAYTHEON		RAYTHEON COMPANY LEXINGTON, MASS. 02173	
PROGRAM/ROUTINE/SUBROUTINE/ACRONYM		IEW'S SORTER SUPV	
SC MESSAGE HANDLING			
CODE IDENT NO	PREPARED BY	DATE	
49956	T. CH. RNESKY	12 APR 76	
NUMBER	35	SHEET	4 OF 8

DELETE TRACK FILE

OP- CODE = 11

SSCM11

CLEAR VALID BIT IN TC DATA BUFF

WRITE TC DATA BUFF INTO TRK FILE N

CALCULATE EMTB ENTRY ADDR

GET EMTB ENTRY FLAG WORD

THROTTLED N FILE?

GET THROTTLE FILE NO.

CLEAR VALID BIT IN IB CAM FILE

INIT THROTTLE TABLE ENTRY

SSCM11A

SET NON-VALID FLAG IN EMTB ENTRY

1A

Return any new emitted pow blocks

Return any update pow blocks

1A

FREQUENCY MODIFICATION

OP- CODE = 12

SSCM12

GET NEW FREQUENCY

READ TRKN INTO TC DATA BUFF

STORE NEW FREQ. IN TC DATA BUFF

WRITE TC DATA BUFF INTO TRK FILE N

CALCULATE EMTB ENTRY ADDR

GET EMTB ENTRY FLAGS

THROTTLED N FILE? 1A

GET THROTTLE FILE NO. FROM EMTB

WRITE FREQ. INTO IB CAM FILE

1A

RAYTHEON		RAYTHEON COMPANY LEXINGTON, MASS. 02173	
PROGRAM/ROUTINE/SUBROUTINE/ACRONYM JEWS SORTER SUPV			
SC MESSAGE HANDLING			
CODE (UNIT) NO 49956	PREPARED BY T. CHERNESKY	DATE 12 APR 76	
NUMBER 36	SHEET 5 OF 8		

PRI MODIFICATION
OF TRACK N.
OP CODE = 13
SSCM13

READ TRK N
CONTENTS
INTO TC
DATA BUFF

GET NEW
PRIA FROM
SC MSG

PUT INTO
TC DATA
BUFFER

GET
NEW
PRIB

PUT INTO
TC DATA
BUFFER

3A

AOA THRESHOLD
MODIFY.
OP CODE = 15
SSCM15

GET TO-NESU
MSG NO.
(= 4)

3B

THROTTLE FILE MODIFY.
OP CODE = 14
SSCM14

CALCULATE
EMTB ENTRY
ADDR

GET EMTB
ENTRY
FLAGS

SET
THROTTLE
FLAG BIT

GET THROTTLE
FILE NO.
FROM SC MSG

SAVE IN
EMTB
ENTRY

COMPUTE
THROTTB
ENTRY ADDR

SAVE EMITTER
NO. IN
THROTTB

GET REDUCT.
FACTOR FROM
SC MSG

SAVE IN
THROTTB
ENTRY

WRITE
REDUCTION
FACTOR INTO
IB CAM

6A

6A

GET NEW
FREQ. FROM
SC MSG

WRITE
FREQ. INTO
IB CAM

GET NEW
AZIMUTH
FROM SC
MSG

WRITE
AZIMUTH
AND VALID
INTO IB CAM

1A

RAYTHEON		RAYTHEON COMPANY LEXINGTON, MASS. 02173	
PROGRAM/ROUTINE/SUBROUTINE/ACRONYM IEWS SORTER SUPV			
SC MESSAGE HANDLING			
CODE IDENT NO 49956	PREPARED BY T. CHERNESKY	DATE 12 APR 76	
NUMBER 37	SHEET 6 OF 8		

CREATE FILE.
OP-CODE = 16
SSCM16

CALCULATE
EMTB ENTRY
ADDR

GET EMTB
ENTRY
FLAGS

SET EMITTER
PRIORITY
TO LO DATA
RATE

INITIALIZE
EMTB
ENTRY

SSCM16A

COPY TRK
DATA TO TC
DATA BUFF

GET
TRACK
NO.

WRITE TC
DATA BUFF
INTO TDM

IS
TO-SC LO-PRI Y.
BUFF BUSY?

SEND CONFIRM
FILE CREATION
MSG TO SC

1A

UPDW STOP
OP-CODE = 17
SSCM17

DISABLE
UPDWS
VIA TC

1A

PW MODIFY OF TRACK N
OP-CODE = 18
SSCM18

READ TRKN
INTO TC
DATA BUFF

GET NEW
PW FROM
SC MSG

PUT INTO
TC DATA
BUFFER

3A

TRANSFER TABLE
OP-CODE = 19
SSCM19

GET ADDR
OF 8-WORD
BLOCK TO BE
SENT TO SC

IS
TO-SC LO-PRI Y.
BUFF BUSY?

SSCM19A

PUT 8 WORDS
OF SORTER MEM.
IN MSG
BUFFER

PUT OP-CODE
IN MSG
BUFFER

SET FLAG
AND WORD
COUNT

1A

RAYTHEON		RAYTHEON COMPANY LEXINGTON, MASS. 02173	
PROGRAM ROUTINE SYMBOLS ALGORYTHM ILLUS SORTER SUPV			
SC MESSAGE HANDLING			
49956	T. CHERNESKY	DATE	3 JUN 76
ISSUED BY	33	SHEET	7 OF 8

MODIFY SORTER MEMORY
 OP-CODE = 1A
 SSCM1A

GET ADDR
 OF WORD TO
 BE MODIFIED

REPLACE
 CONTENTS
 OF WORD

1A

RAYTHEON		RAYTHEON COMPANY LEXINGTON, MASS 02173	
PROGRAM/ROUTINE/SUBROUTINE ACRONYM		ILWS SORTER SUPV	
SC MESSAGE HANDLING		DATE	
CODE IDENT NO	PREPARED BY	DATE	
49956	T. CHERNESKY	12 APR 76	
NUMBER	39	SHEET 8 OF 8	

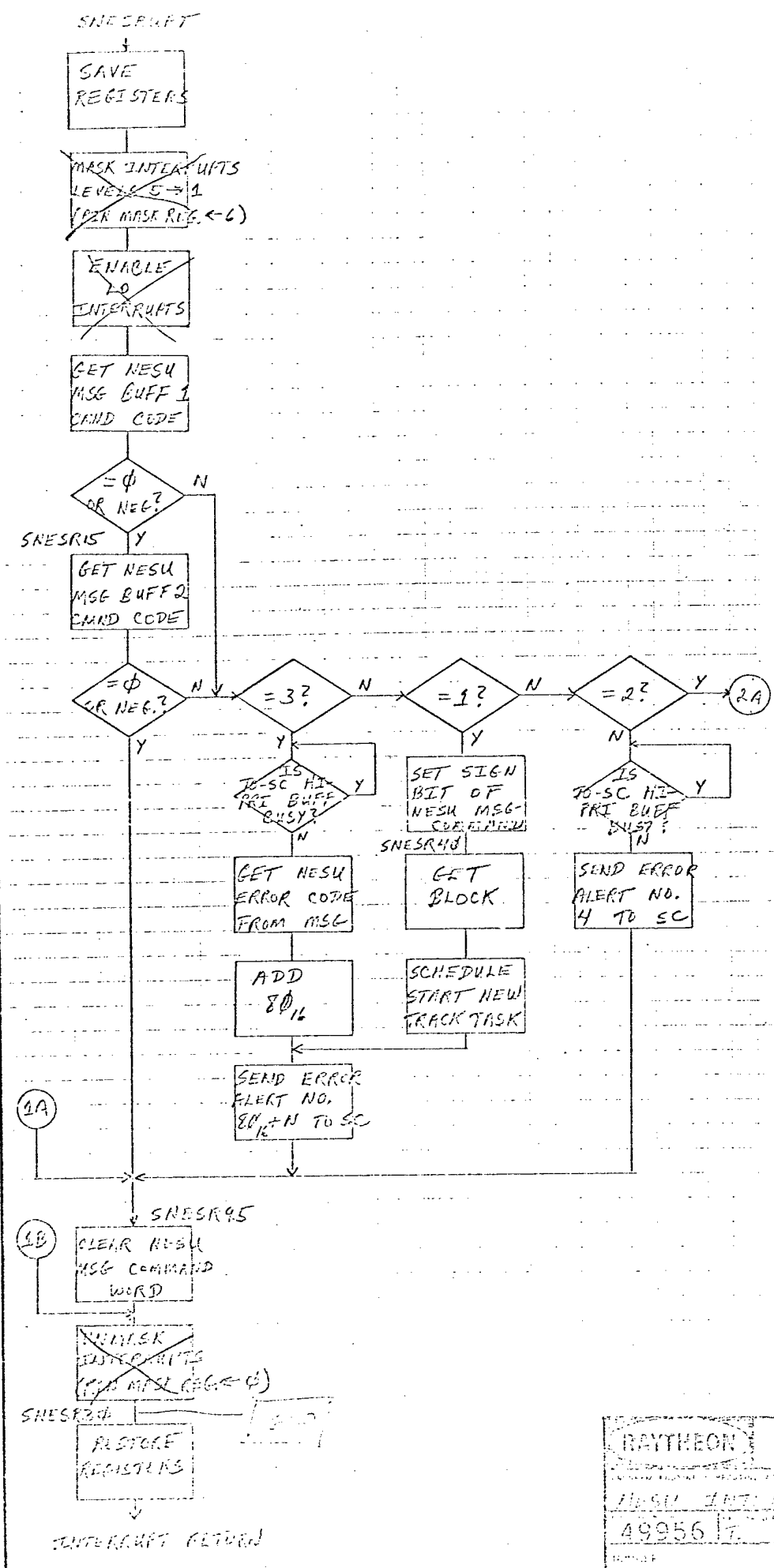

NEGATIVE COMMAND CODE MEANS NEW EMITTER ALERT MSG HAS BEEN PUT IN THIS BUFFER BY NESU AND IS BEING PROCESSED. (I.E., START NEW TRACK HAS BEEN SCHEDULED.)

ERROR ALERT NO. 4 MEANS "INVALID MSG REC'D FROM NESU"

RAYTHEON RAYTHEON COMPANY
 LEXINGTON MASS 02173
 JAMES DONNER DIV
 49956
 25 1000 OF 2

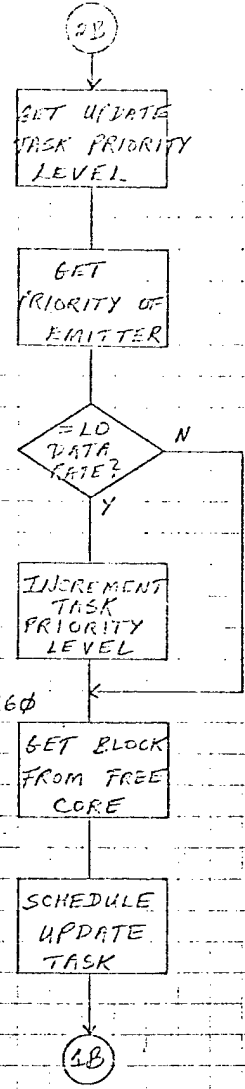
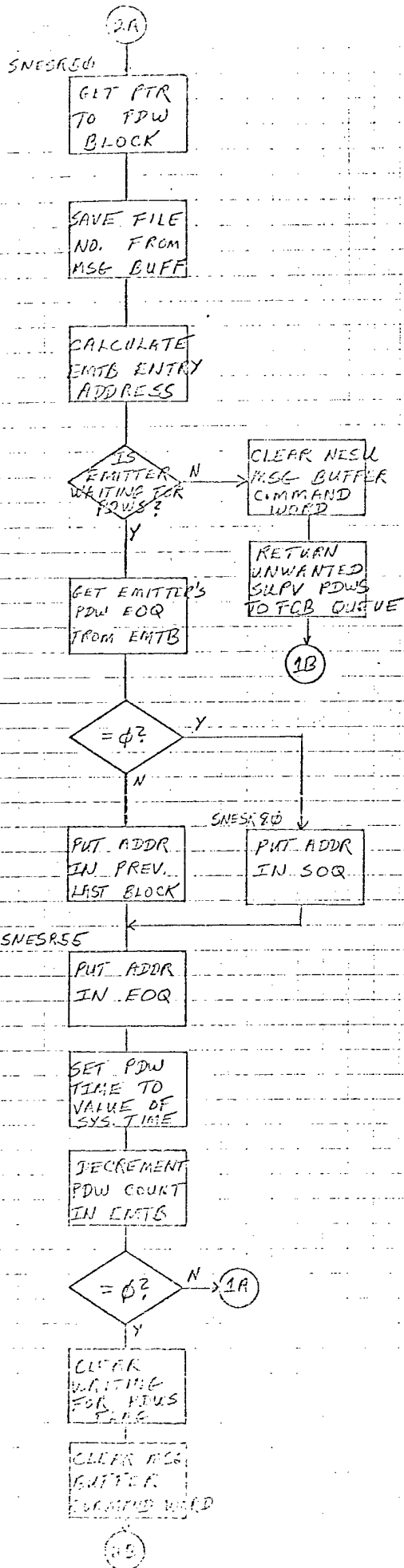

RAYTHEON RAYTHEON COMPANY
 LEXINGTON, MASS 02173

NEW JERSEY

49956

RAYTHEON COMPANY

OF 2

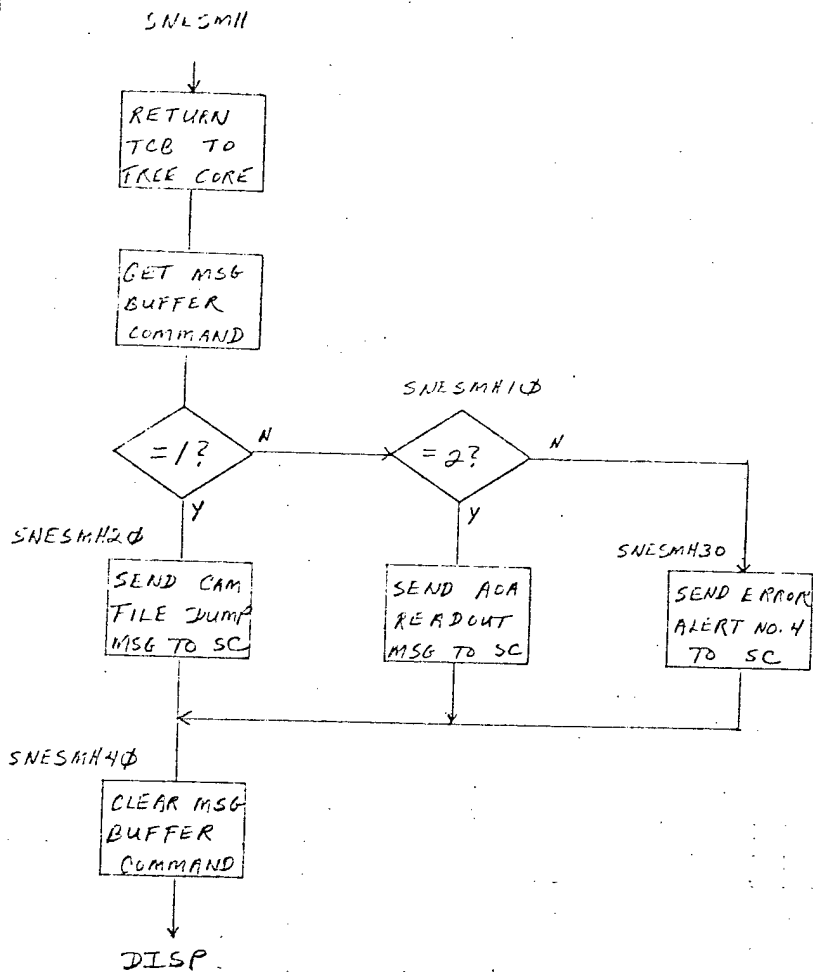

RAYTHEON		RAYTHEON COMPANY LEXINGTON, MASS 02173	
PROGRAM/ROUTINE/SUBROUTINE/ACRONYM NEWS SORTER SUPV			
MESSAGE HANDLER			
CODE IDENT NO	PREPARED BY	DATE	
49956	T. CHERNESKY	12 APR 76	
NUMBER	28		SHEET 1 OF 1

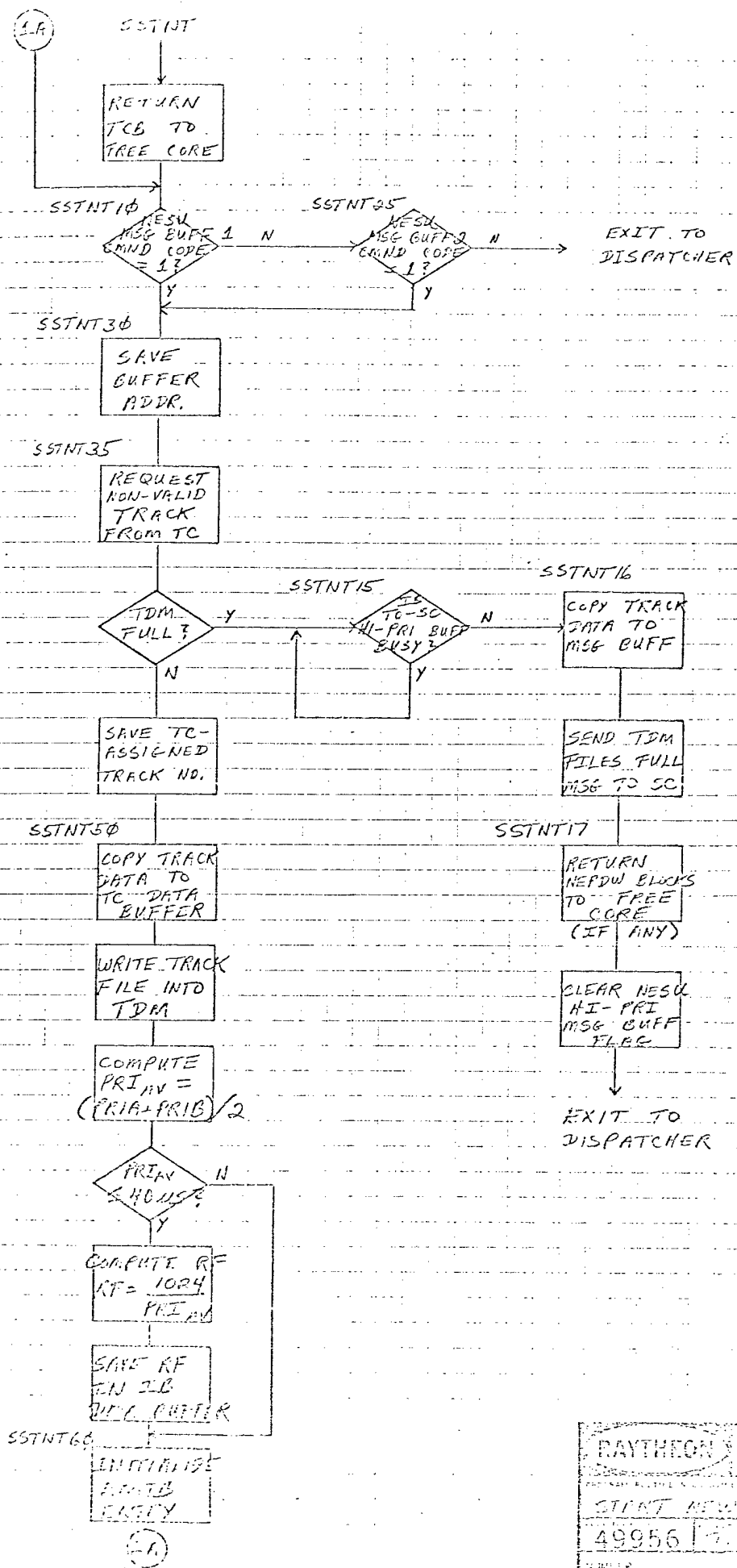

PRI_AV < 40MS.
MEANS THROTTLE
OF NEW EMITTER
IS REQUIRED.

'RF' MEANS
'REDUCTION
FACTOR'

RAYTHEON RAYTHEON COMPANY
LEXINGTON, MASS 02173

STANT NEW TRACK TRACK

49956

1 OF 2

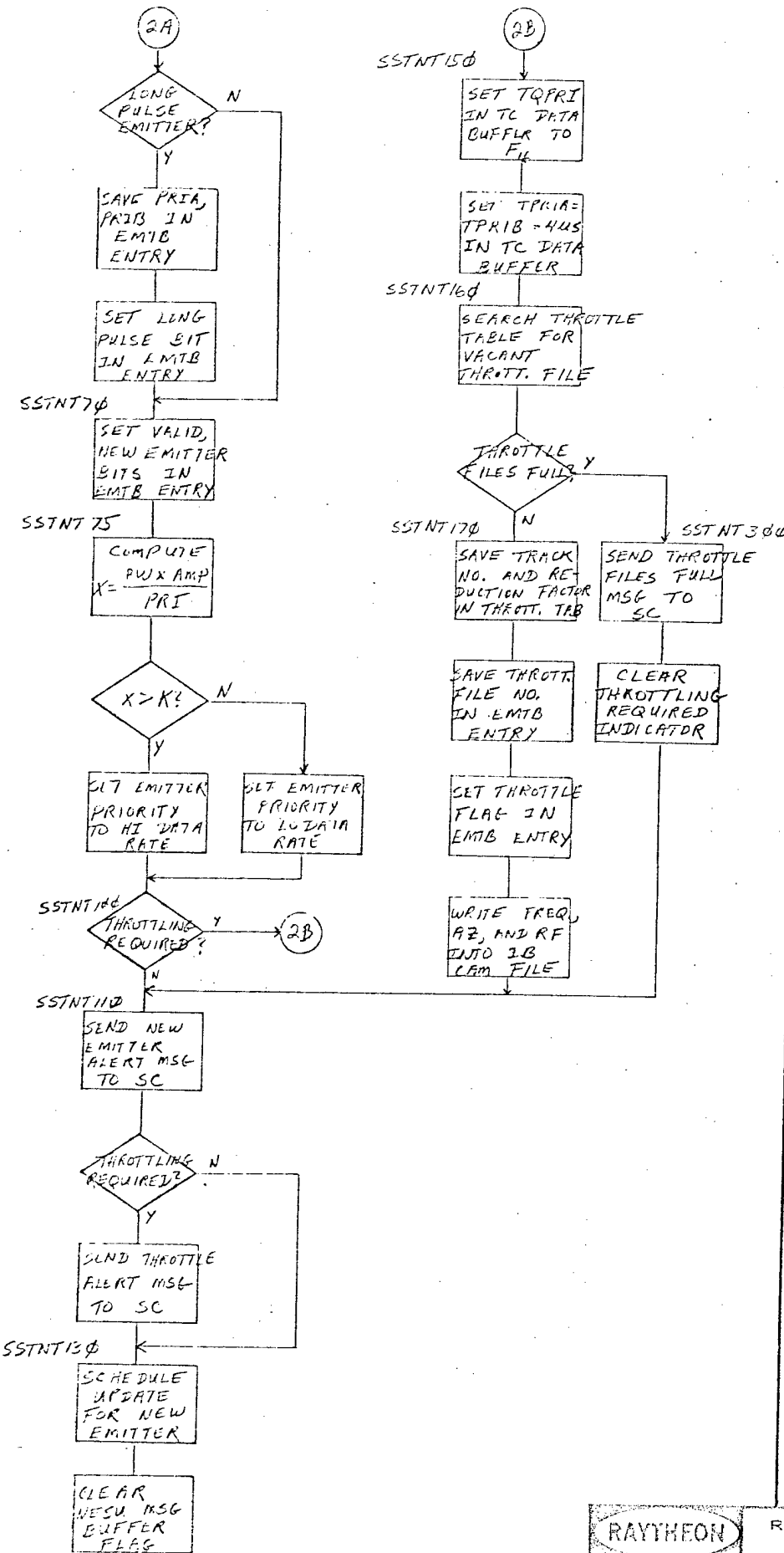

RAYTHEON		RAYTHEON COMPANY LEXINGTON, MASS. 02173	
PROGRAM POLLINE SUBJECTIVE ACRONYM IEWS SORTER SUPV			
START NEW TRACK TASK			
CODE 49956	PREPARED BY T. CHERNESKY	DATE 3 MAY 76	
NUMBER	36	SHEET 2 OF 2	