



NRL/MR/6170--99-8335

Thermal Plasma Waste Remediation Technology: Historical Perspective and Current Trends

DAVID A. COUNTS

*Geo-Centers Inc.
Ft. Washington, MD*

BRUCE D. SARTWELL

*Surface Chemistry Branch
Chemistry Division*

STEVEN H. PETERSON

*Geo-Centers Inc.
Lanham, MD*

ROBERT KIRKLAND

*Diagnostics Instrumentation and Analysis Laboratory
Mississippi State University, Starkville, Mississippi*

NICHOLAS P. KOLAK

*New York State Department of Environmental Conservation
Albany, New York*

January 29, 1999

Approved for public release; distribution unlimited.

1 9 9 9 0 2 2 2 0 3 6

REPORT DOCUMENTATION PAGE

Form Approved
OMB No. 0704-0188

Public reporting burden for this collection of information is estimated to average 1 hour per response, including the time for reviewing instructions, searching existing data sources, gathering and maintaining the data needed, and completing and reviewing the collection of information. Send comments regarding this burden estimate or any other aspect of this collection of information, including suggestions for reducing this burden, to Washington Headquarters Services, Directorate for Information Operations and Reports, 1215 Jefferson Davis Highway, Suite 1204, Arlington, VA 22202-4302, and to the Office of Management and Budget, Paperwork Reduction Project (0704-0188), Washington, DC 20503.

1. AGENCY USE ONLY (Leave Blank)	2. REPORT DATE January 29, 1999	3. REPORT TYPE AND DATES COVERED Final Report	
4. TITLE AND SUBTITLE Thermal Plasma Waste Remediation Technology: Historical Perspective and Current Trends		5. FUNDING NUMBERS	
6. AUTHOR(S) David A. Counts,* Bruce D. Sartwell, Steven H. Peterson,† Robert Kirkland‡ and Nicholas P. Kolak**		8. PERFORMING ORGANIZATION REPORT NUMBER NRL/MR/6170-99-8335	
7. PERFORMING ORGANIZATION NAME(S) AND ADDRESS(ES) Naval Research Laboratory Washington, DC 20375-5320		10. SPONSORING/MONITORING AGENCY REPORT NUMBER	
9. SPONSORING/MONITORING AGENCY NAME(S) AND ADDRESS(ES) Naval Research Laboratory Washington, DC 20375-5320		11. SUPPLEMENTARY NOTES *Geo-Centers, Inc., Ft. Washington, MD †Geo-Centers, Inc., Lanham, MD ‡Mississippi State University, Starkville, MS **New York State Dept of Environmental Conservation, Albany, NY	
12a. DISTRIBUTION/AVAILABILITY STATEMENT Approved for public release; distribution unlimited.		12b. DISTRIBUTION CODE A	
13. ABSTRACT (Maximum 200 words) The idea of utilizing thermal plasma technology for waste processing goes back to the mid-1970's during the energy crisis. Since then, more interest has been shown by universities, industry, and government in developing thermal plasma waste processing technology for hazardous and non-hazardous waste treatment. Much of the development has occurred outside of the United States, most significantly in Japan and France, while the market growth for thermal plasma waste treatment technology has remained slow in the United States. Despite the slow expansion of the market in the United States, since the early 1990's there has been an increase in interest in utilizing thermal plasma technology for environmental remediation and treatment in lieu of the more historical methods of incineration and landfilling. Currently within the Department of Defense there are several demonstration projects underway, and details of some of these projects are provided. Prior to these efforts by the U.S. Government, the State of New York had investigated the use of thermal plasma technology for treating PCB contaminated solvent wastes from the Love Canal cleanup. As interest continues to expand in the application of thermal plasma technology for waste treatment and remediation, more and more personnel are becoming involved with treatment, regulation, monitoring, and commercial operations and many have little understanding of this emerging technology. To address these needs, this report will describe: (1) characteristics of plasmas; (2) methods for generating sustained thermal plasmas; (3) types of thermal plasma sources for waste processing; (4) the development of thermal plasma waste treatment systems; and (5) Department of Defense plasma arc waste treatment demonstration projects.			
14. SUBJECT TERMS Thermal plasma Waste treatment		Remediation Plasma torch	15. NUMBER OF PAGES 37
17. SECURITY CLASSIFICATION OF REPORT UNCLASSIFIED		18. SECURITY CLASSIFICATION OF THIS PAGE UNCLASSIFIED	16. PRICE CODE 19. SECURITY CLASSIFICATION OF ABSTRACT UNCLASSIFIED
20. LIMITATION OF ABSTRACT UL			

CONTENTS

1.0	INTRODUCTION	1
2.0	CHARACTERISTICS OF PLASMAS	3
3.0	METHODS FOR GENERATING SUSTAINED THERMAL PLASMAS	4
4.0	WASTE PROCESSING THERMAL PLASMA TORCH DESIGNS	7
5.0	HISTORICAL DEVELOPMENT OF THERMAL WASTE PROCESSING SYSTEMS ..	11
6.0	DEPARTMENT OF DEFENSE PLASMA ARC DEMONSTRATION PROJECTS	16
7.0	FUTURE DEVELOPMENTS	22
8.0	CONCLUSIONS	24
9.0	ACKNOWLEDGMENTS	25
10.0	REFERENCES	26
	APPENDIX A—List of U.S. Firms Involved with Thermal Plasma Waste Treatment	32

THERMAL PLASMA WASTE REMEDIATION TECHNOLOGY: HISTORICAL PERSPECTIVE AND CURRENT TRENDS

1.0 Introduction

The idea of utilizing thermal plasma technology for waste processing goes back to the mid-1970's during the energy crisis [1,2]. At that time, the intention was to use thermal plasma systems for resource recovery. Since then, more interest has been shown by universities, industry, and government in developing thermal plasma waste processing technology for hazardous and non-hazardous waste treatment. Much of the development has occurred outside of the United States, most significantly in Japan and France, while the market growth for thermal plasma waste treatment technology has remained slow in the United States. Despite the slow expansion of the market in the United States, since the early 1990's there has been an increase in interest in utilizing thermal plasma technology for environmental remediation and treatment in lieu of the more historical methods of incineration and landfilling [3 - 24].

Several agencies in the United States Government have been investigating thermal plasma technology as a treatment method in various environmental cleanup and compliance programs. The Department of Energy has focused its thermal plasma research on mixed nuclear waste vitrification. The Environmental Protection Agency is currently establishing a laboratory for investigating thermal plasma technology, under a cooperative agreement with Plasma Energy Corporation. Currently within the Department of Defense there are several demonstration projects underway, and details of some of these projects are provided in Section 6.0. Prior to these efforts by the U.S. Government, the State of New York had investigated the use of thermal plasma technology for treating PCB contaminated solvent wastes from the Love Canal cleanup [25,26]. Alongside these efforts by both state and federal governments, many prototype and pre-prototype systems have been built and tested in the private sector.

The Department of the Navy has shown an interest in the development and application of thermal plasma technology to address the formidable problems relative to the disposal of waste at sea. Naval vessels have restrictions on both the size and weight of waste processing equipment that are not encountered on land-based units or even commercial seagoing vessels. In the early 1990's, the Environmental Quality Department (EQD) of the Naval Surface Warfare Center (NSWC) - Carderock Division, conducted feasibility studies to determine if it would be possible to deploy a plasma arc system on large Navy ships. They concluded that it was feasible but that significant developmental work would be required. In 1993 the Naval Research Laboratory (NRL) purchased a laboratory scale plasma arc system under the Environmentally Sound Ships Program to investigate the use of thermal plasma technology in treating Navy shipboard waste. NRL became interested in thermal plasma waste treatment technology when it was recognized that the technology could potentially be utilized as a means of treating Navy shipboard waste, in order to keep the Navy in compliance with International treaties and Congressional mandates [27]. Since the system was installed at NRL numerous modifications have been made in order to conduct research on destroying various types of wastes.

As interest continues to expand in the application of thermal plasma technology for waste treatment and remediation, more and more personnel are becoming involved with treatment, regulation, monitoring, and commercial operations and many have little understanding of this emerging technology. To address these needs, this report will describe: (1) characteristics of plasmas; (2) methods for generating sustained thermal plasmas; (3) types of thermal plasma sources for waste processing; (4) the development of thermal plasma waste treatment systems; and (5) Department of Defense plasma arc waste treatment demonstration projects. Appendix A lists some of commercial firms in the United States that are involved in thermal plasma waste processing.

2.0 Characteristics of Plasmas

Solids, liquids, and gases comprise only a small part of the total amount of known matter in the universe. Stars and the material present in glowing clouds between stars exist in the fourth state of matter known as the plasma state. Astronomers estimate that 99% of the material in the universe exists as plasma. As additional energy is added to atoms in the gaseous state, the atoms collide with each other with more energy and with greater frequency. At about 3600° F (2,000° C), molecules dissociate into the atomic state. As the temperature is increased further to 5400° F (3,000° C), these collisions result in electrons being ejected and the atoms become ionized. As an increasing number of atoms in the gas lose their electrons, the gas becomes a mixture of positive ions and electrons. In this hot, ionized state, the gas is electrically conducting, can be confined by electromagnetic fields, and has an almost liquid-like viscosity. This gaseous mixture is called a plasma. Examples of naturally occurring plasmas are the sun, Aurora Borealis, and a bolt of lightning. Examples of artificial plasmas are fluorescent light tubes, thermonuclear explosions, and plasma torches. A plasma is defined as thermal if it is close to thermal equilibrium. Thermal equilibrium is when the electrons and ions of the plasma have the same characteristic temperature. In a non-thermal plasma, such as what occurs in a fluorescent lamp, the effective temperature of the electrons is considerably higher than that of the ions.

The unique characteristics of thermal plasmas, such as their energy content (enthalpy), has attracted scientists and engineers to adapt thermal plasma technology to industrial processes. While fossil fuel combustion with air has an upper practical temperature range of 3,600° F (2,000° C), thermal plasmas can produce temperatures of 36,000° F (20,000° C) or more. It is precisely this one order of magnitude increase in enthalpy of thermal plasmas over fossil fuel combustion that has led to industrial utilization and attempts to apply thermal plasma technology to the treatment of various wastes.

3.0 Methods for Generating Sustained Thermal Plasmas

One of the first uses of thermal plasma technology was in carbon-arc lamps in lighthouses; smaller versions of the carbon arc lamp were used in early movie projectors. Initial research into thermal plasmas goes back to the early 1800's where batteries were utilized as the power source. The establishment of stable electric power grids in the latter 1800's allowed exploration of industrial applications of thermal plasmas. The first commercial successes were the Siemens arc furnaces in 1878 [28 – 32].

Thermal plasmas are generated in various ways, but in general, the generation of a stable thermal plasma requires three components:

1. An electrical power supply and circuitry capable of generating and sustaining a plasma at the power level desired.
2. A stable source of plasma gas or gases. Usually simple monatomic or diatomic gases such as helium, argon, or nitrogen, are used. More complex molecules, such as benzene, ethylene, or sulfur hexafluoride have been used in certain applications.
3. Appropriate hardware configuration. This involves the mechanical assembly of the electrode(s), which is commonly referred to as the plasma torch.

Historically, a two-electrode configuration with two rods was used in which a high electrical potential is applied to the electrodes and the plasma gas is then introduced. As the rods are brought closer together, the air gap is ionized and a plasma is formed. The rods are then separated and kept at a distance from each other as determined by the voltage. This simple configuration is very robust and has been used over a wide pressure range from below atmospheric to up to five times atmospheric pressure, and with a wide range of gases. Modern designs use sophisticated starting methods, can use either AC or DC power supplies, and have multiple electrodes. The principle problem with the electrode method is that the electrodes erode from exposure to high current flux and chemical attack, and as a result electrodes must be replaced frequently. Research efforts continue to be directed at extending the lifetime of the electrodes [28 – 32].

Since 1878 there have been many variations on the plasma torch components and designs [33 – 35] with significant advances made in the design of plasma torches, the methodologies of starting or initiating plasmas, and system integration. There are two principal sub-categories of water-cooled direct current plasma torches, and they are classified by their operating modes. These are transferred arc and non-transferred arc, which are illustrated in Figure 1 [35]. Plasma torches that operate on alternating current represent a separate category.

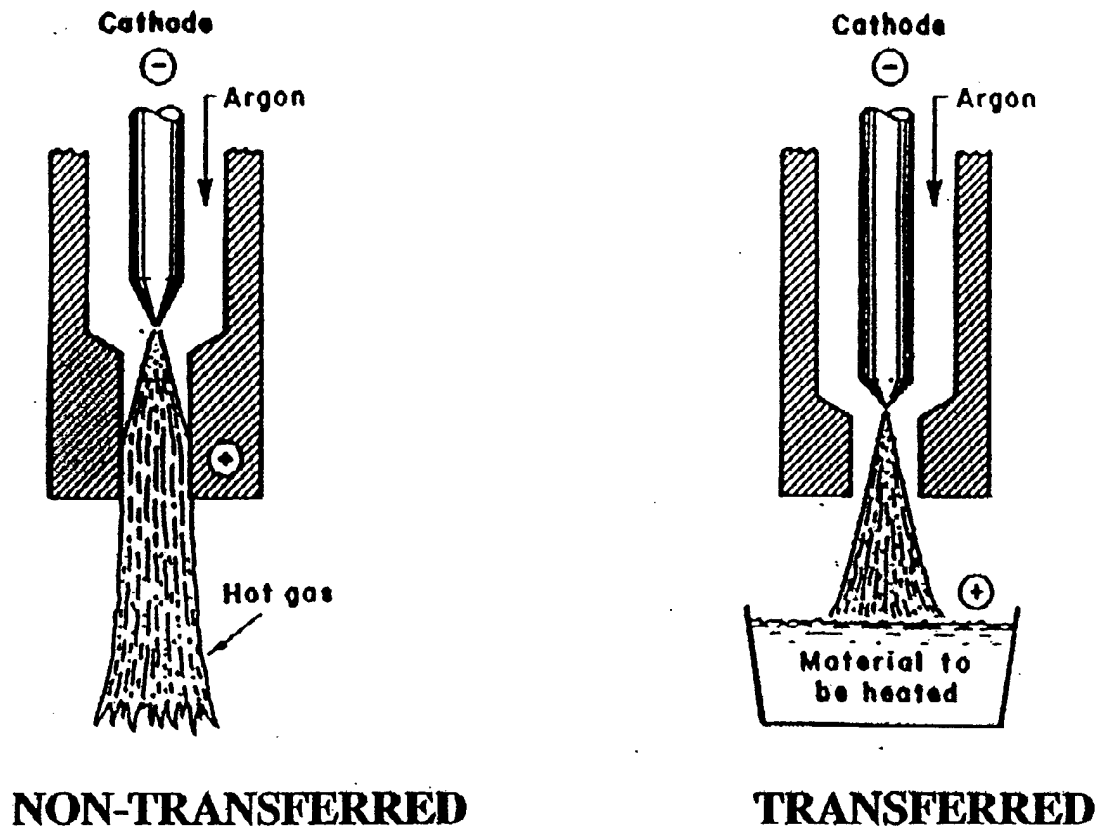

Figure 1: Non-Transferred and Transferred Plasma Torch Modes of Operation, [35]

The transferred arc design contains only one electrode in the torch, with the material to be processed as the other electrode. After initiating the arc on a suitable conducting surface, the torch is slowly positioned above the material to be processed. As the material melts, it becomes electrically conducting and the torch is moved further away from the initial starting point. After a molten bath is established and stabilized, additional material to be processed is introduced by a feed system. This operating mode works well for metallurgical processing, ore processing, mixed waste vitrification, and any process where a large heat source is needed. The transferred arc is also found in metal cutting and welding. In principle, the electrode in the torch can either be the cathode or anode, but in general the erosion rate of the cathode is approximately 100 times higher than that of the anode. Therefore, for transferred arc operation, it is more logical to operate with the anode in the torch and use the material being processed as the cathode [36].

The non-transferred arc design has both of the electrodes in the torch assembly. The arc is commonly initiated using one of three methods:

- 1) A sacrificial electrode is brought close to one of the electrodes.
- 2) The electrodes start close together, a low ionization gas is introduced and the electrical potential is brought up to 1,000 Volts. Once the plasma arc is initiated the electrodes are separated.
- 3) A high frequency starter is used to initiate the plasma first by induction, then the circuitry allows transition to an electrode-based plasma.

A plume of plasma and hot gas is ejected from the end of the torch. The non-transferred mode has been successfully used for chemical production and synthesis, scrap metal recovery, plasma spraying, metal cutting, organic waste processing, and testing of aerospace heat shielding.

4.0 Waste Processing Thermal Plasma Torch Designs

Current plasma torch designs are based on the Siemens transferred arc furnace (1878), Siemens non-transferred torch (1878), Huls non-transferred torch (1923), Union Carbide Plasmarc furnace (1958), and the Union Carbide non-transferred torch (1963). The Huls torch was designed for production of acetylene and light hydrocarbons, while the Siemens and Union Carbide torches were designed for metals processing [28 – 32]. Some of the early research work showed that while stick-type electrodes can be used to generate thermal plasmas, there has to be a continual feed of the electrode material to compensate for the rate of erosion. One of the significant results of the research conducted in the 1950's was to move away from stick-type electrodes in plasma torch design.

Plasma torches today have two basic designs. The first is the well-type, or hollow electrode, anode (Figure 2), which descends directly from the Union Carbide designs [37 – 47]. The second is the co-planar tubular electrode (Figure 3), a derivative of the Union Carbide non-transferred design [37, 48 – 64]. These two designs have been very successful in terms of improved electrode lifetimes and plasma stability.

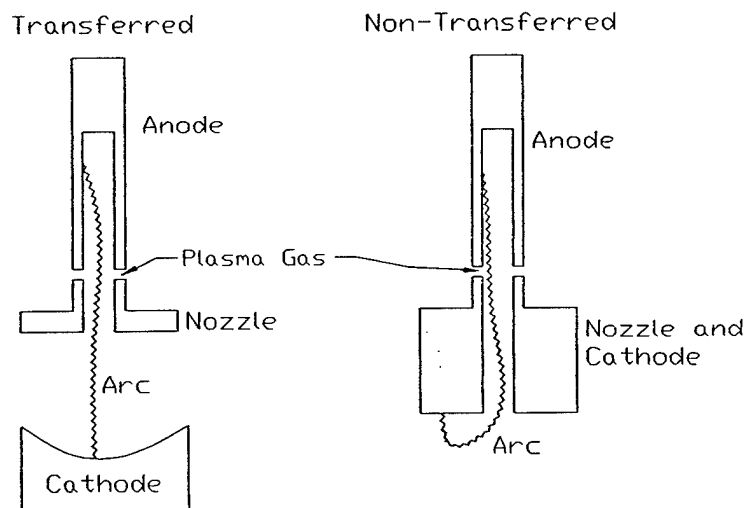
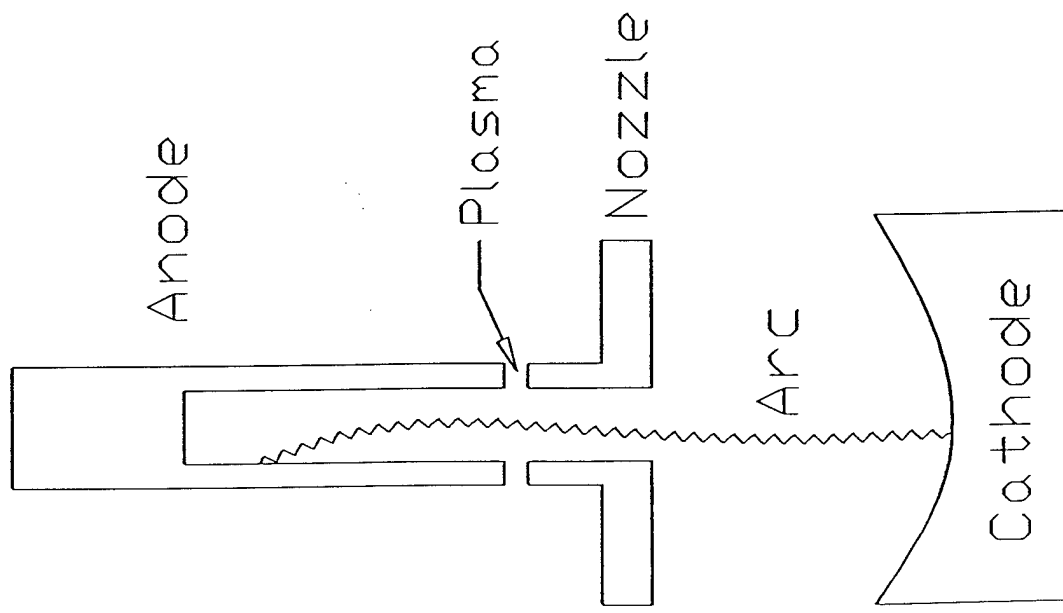

Figure 2: Well-Type Anode Torch

The well-type anode torch gets its name from the contrast between the stick electrode and one that has its center bored out. The arc originates from the side wall of the well. Figure 2 shows the well-type anode torch in both the transferred and non-

Transferred



Non-Transferred

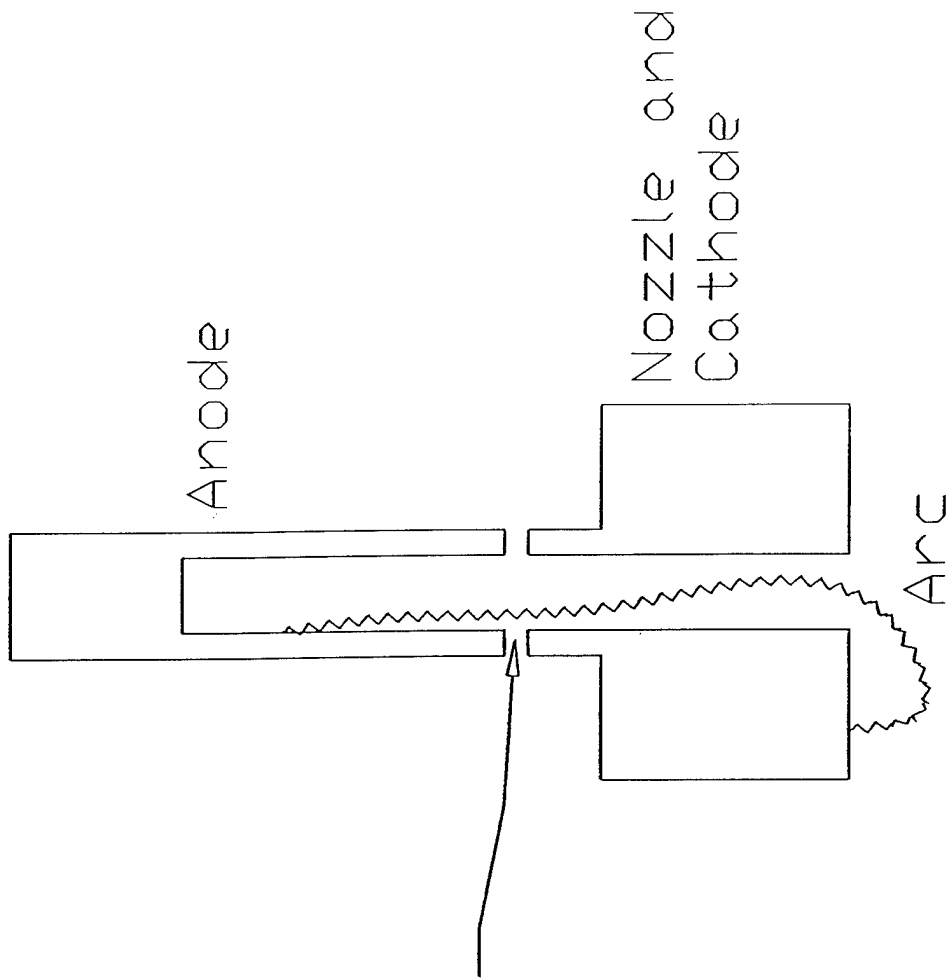

transferred mode. This type of torch is used to produce stable transferred arc operation or when it is desired to place the plasma torch at the end of a mechanical ram or arm to position the plasma onto a target. In both transferred and non-transferred mode the gas is injected tangentially and the vorticity of the gas helps move the arc around the anode; the movement of the point of contact reduces localized erosion and extends the lifetime of the anode.

The major challenge for non-transferred torches is the need to extend electrode lifetimes. Westinghouse and others have developed the co-planar tubular electrode design, in which magnetic rotation of the arc, in addition to gas vorticity, reduces the specific wear on the electrodes [48, 50, 51, 58, 60, 64 – 67]. Figure 3 shows an idealization of this design. A 2,000 hour continuous usage of this design has been documented in high power (>250kW) operations.

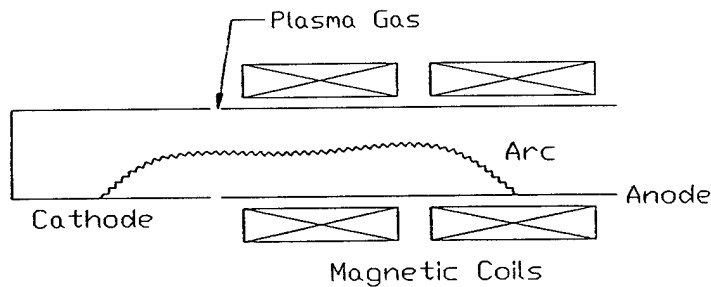
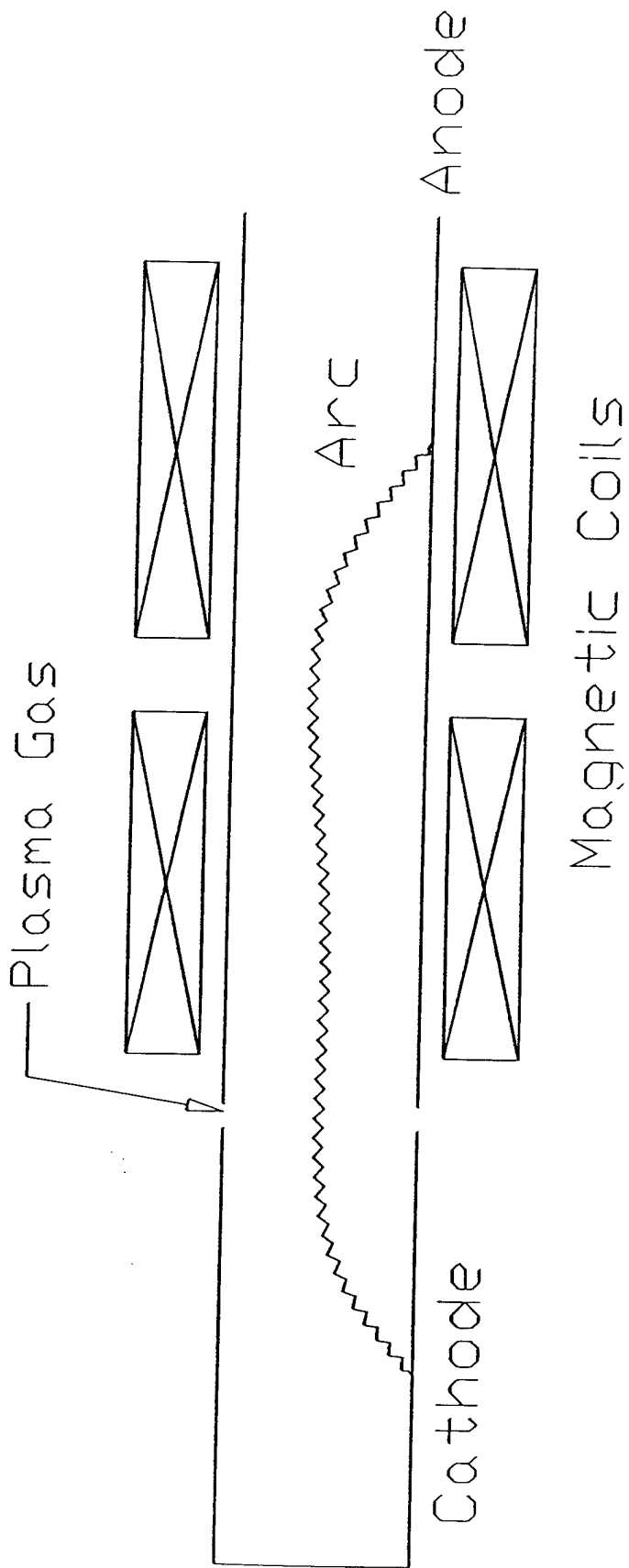

Figure 3: Stylization of Westinghouse Non-Transferred Torch

Although some progress has been made, work is continuing to be directed at improving the designs of plasma torches for thermal waste processing. Research goals are to extend electrode life, improve the efficiency of the power delivered, and enhance the economics. Work towards these goals has led to many variations of non-transferred designs. The basic Union Carbide transferred torch design has been validated by the many copies made of it and its consistency in use today. The variations of non-transferred torch design have been driven by the same objective - a thermal source for industrial processing.



5.0 Historical Development of Thermal Plasma Waste Processing Systems

Thermal plasma technology has been successfully used in many industrial applications, from the processing of ores to the welding and cutting of metals. As far back as 1923, the Huls process was designed around a plasma torch for the production of acetylene. More recently, the quest to conquer space in the 1950's and 1960's required further advances in plasma torches for the purpose of testing heat shields on re-entry vehicles. The latter effort resulted in the development of high enthalpy gas heaters based on the non-transferred arc geometry. The continued expansion of applications for thermal plasmas has led to advances in plasma torch design [3, 28 – 32].

During the 1960's thermal plasma systems were being applied to the metals processing industry for ore reduction, scrap metal recovery, and high temperature alloying. Thermal plasma provided high temperatures and a controlled environment that are important in producing high quality products involving titanium, tungsten, and steel alloys. In processing metals with a thermal plasma, a molten bath is generated where the pure metals are separated from the impurities. The impurities form a slag which floats on the metal and is readily separated. The molten metal is drawn off, thereby recovering purified metal product.

It was recognized that with some modifications thermal plasma metal-processing systems could be applied to safe processing of hazardous wastes [1 – 24, 68]. Thermal plasmas provide a heat source for keeping a molten slag bed at a high temperature (1000 to 1500 degrees Celsius). With this heat source, organic wastes could be separated from soils, mixed scrap, etc. The organic waste does have to go through a secondary treatment system to assure full oxidation but that technology is available commercially. These systems offer a method of introducing a mixture of organic and inorganic waste to destroy the contaminants while allowing for the recovery of metals.

Despite the obvious capabilities and numerous concepts for using thermal plasma systems for treating wastes, there have not been any thermal plasma based systems built for processing municipal waste in the United States [1, 2, 5 – 9, 12, 14, 15, 20 – 22]. It has been difficult to achieve an economic advantage over conventional incineration and landfilling. Dr. Emil Pfender, Professor Emeritus at The High Temperature Laboratory of the Mechanical Engineering Department at the University of Minnesota, stated that whenever another technology is effective, the economics will dictate the usage of that technology, unless special circumstances prevail, [69]. Special circumstances that could favor use of plasma arc technology are the requirement for a mobile system, treatment of mixed nuclear waste, treatment of hazardous (non-radioactive) waste, demilitarization of ordnance and chemical weapons, and regulatory driven requirements.

In this section three representative projects are described that show how thermal plasma technology can be applied to waste processing.

- The first project occurred in the early 1980's and was jointly sponsored by the New York State Department of Environmental Conservation (NYSDEC) and the USEPA. The objective of that effort was to develop a mobile system to treat liquid hazardous wastes.
- The second project is the hazardous waste vitrification facility in Muttenz, Switzerland, operated by MGC Plasma and built by the Retech Division of Lockheed Martin Advanced Environmental Systems.
- The third project is the ash vitrification system in Japan that was built by Plasma Energy Corporation.

The following discussion presents the goals and problems of each project, along with how the wastes were processed.

5.1 New York State Mobile Plasma-Based Treatment System

During the cleanup of the Love Canal hazardous waste site in the 1980s, an on-site wastewater plant had been built to treat contaminated groundwater. The treatment plant operations resulted in the production of several hundred gallons per month of a non-aqueous phase liquid (NAPL) that contained hundreds of toxic chemicals. Because the NAPL also contained high levels of dioxin, federal regulations prohibited transport off site. Thus, four 10,000 gallon tanks were built on site for the temporary storage of NAPL. At the time there was no permitted treatment method within New York State or the country which could destroy this material. As the inventory of NAPL increased and the operations were faced with the need to construct additional storage tanks, Dr. Nick Kolak (NYSDEC) proposed that a treatment system be developed based upon plasma technology. To help justify the cost of development, the mobile system could be used in the clean-up of other inactive hazardous waste sites within New York State.

The challenge was to develop a mobile technology that could achieve the high destruction and removal efficiency (DRE) established by the USEPA for PCBs, dioxins, and other reactive chemicals. The system design was further challenged in that the process had to possess a practical throughput while being economical. In concept, it was believed that plasma technology could meet these three major requirements. Thus, both agencies embarked on the design and construction of a mobile unit, one that would have to be tested and certified by both the USEPA as well as the regulatory side of NYSDEC. Because no state had previously attempted the development of such a complex technology, this program was truly a groundbreaking effort by government.

The final design of the system called for directly introducing the liquid waste into a modified Westinghouse Mark 11 non-transferred plasma torch. This approach made use of the high energy flux in the region of the plasma to thermally destroy the targeted waste. The mobile system was built and operated by Pyrolysis Systems, Inc, Kingston, Ontario, Canada under contract to NYSDEC. Tests using actual PCBs readily achieved a DRE of 99.9999% to satisfy regulatory requirements, [25, 26].

After the successful demonstration in Canada, the system was transported to Niagara Falls, New York for additional testing on the NAPL at Love Canal. Despite the positive test results from the first phase of the test program, operating permits were extremely difficult to obtain. Two years after the PCB data had been submitted, permits to allow additional testing had still not been issued. During this time, funding to keep equipment operational and support contractor personnel had to be maintained even though the test program was stalled. As key participants left the program and additional funding became increasingly difficult to obtain, the project was halted.

The hardware system has since been purchased by Plasma Pyrolysis Systems, Inc. in Stuyvesant Falls, New York where it is being modified to treat medical waste. The system is expected to undergo testing on simulated medical waste in 1998 under research and development permits from the USEPA and NYSDEC.

While New York State's mobile plasma unit never did get a chance to process the targeted waste at Love Canal, in many respects the project has been viewed by many as a research and development success which has since attracted considerable interest from industry, both foreign and domestic. In the time since that project, there have been many forums which have discussed the issue of regulatory impediments toward the development of alternative treatment technologies that are critical to the remediation of hazardous waste sites. In 1990, one such conference was held in New York State and the findings were published in a report [70]. More recently, the United States General Accounting Office has published a study of regulations and the inhibiting effect on environmental cleanup efforts [71, 72]. The ultimate technical challenge in remediating hazardous waste sites is to provide alternative technical solutions which are cost effective and which gain the acceptance and approval of the public.

5.2 MCG Plasma, Muttentz, Switzerland Hazardous Waste Treatment System

The MGC Plasma facility in Muttentz, Switzerland, which was built by Retech Inc., is a demonstration facility for a single site hazardous waste treatment facility capable of processing a wide spectrum of wastes. The MGC Plasma system has an eight foot diameter rotating crucible and a 1.2MW transferred arc thermal plasma torch in the primary processing chamber. The unit is two stories tall and is capable of feeding in 200 liter drums of hazardous waste in a batch mode. The drums are remotely inserted from a control room and can be punctured above the crucible to allow for slow feeding of any liquids present. The metals and inorganic material are vitrified and the resulting glass is a safe, non-leachable material that can be disposed of as non-hazardous waste in a landfill or utilized as aggregate [3, 73 - 76]).

The MGC Plasma facility is designed to accept a wide variety of wastes such as low/medium level radioactive wastes, oil or solvent contaminated dirt, or medical waste. There is a drum storage facility and an analytical chemistry laboratory on-site for determination and/or verification of the contents of the drums. This facility is able to

safely process a wide variety of wastes without operator intervention because the process is a closed loop. In the case of nuclear wastes, vitrified material is sent to a long term storage facility. Emissions monitoring data have indicated that the facility operated within the regulatory requirements, [73 -76].

5.3 Plasma Energy Corporation Ash Vitrification Facility

In 1987 Japan became interested in thermal plasma for the vitrification of ash from municipal solid waste (MSW) incineration plants. Limited land mass in Japan makes landfilling of MSW impractical. Thus, more than 70% of MSW is incinerated in conventional kilns or furnaces. Approximately 15% by weight of the waste is discharged from MSW furnaces as bottom and fly ash, termed MSW ash. Initially, this ash was landfilled; however, legislation now demands this practice be discontinued due to concern over secondary pollution from toxic metals such as cadmium, lead and chromium which reside in the ash.

Two corporations, Ebara Infilco and Kawasaki/Tokyo Electric Power Company were interested in starting pilot plant operations to develop the vitrification process. The corporations chose to utilize plasma torches manufactured by Plasma Energy Corporation, Raleigh, North Carolina (USA). The problem was studied for approximately six years before a commitment to build a commercial scale facility was made. In 1993 a demonstration facility was built by each company. Ebara Infilco built a facility in Handa, Japan, which utilized two 750-kW transferred arc torches with air as the plasma gas. The Kawasaki/TEPCO demonstration facility was built in Chiba and utilized one 1.0-MW transferred arc torch also operated with air as the plasma gas. These facilities could be categorized as commercial facilities. The first truly commercial facility for the treatment of MSW incineration ash was installed in 1994 at Matsuyama by Enbara Infilco. This facility utilized two 1.5-MW transferred arc torches, again with air as the plasma gas. The market has been continually expanding since 1994 and the process is currently being utilized to treat low level radioactive waste.

The process involves high temperature thermal smelting of ash, which can, if necessary, be mixed with carbon-based reductants and/or process flux additives. During the smelting stage the ash liquefies and forms a low viscosity slag. The slag is removed from the vessel, and either granulated by rapid cooling in a water spray or allowed to cool slowly in a mold for various uses.

The loose ash or blended material is unloaded onto a cleated belt conveyor and transported to two treatment vessel feed hoppers selected by a diverter valve. Entry and exit of these hoppers is controlled by alternating slide gates. Water-cooled screw conveyors connect directly to the treatment vessel from the hoppers. Material enters an upper hopper of the feed system only when the exit gate for that particular hopper is closed. The entry gate for the upper hopper is then closed and material is allowed to fall by gravity into the lower hopper where a screw conveyor carries it to the vessel. Screw conveyors are sized to crush the material to a uniform size and speed is controlled to

allow for determination of feed rate and process energy requirements. Hoppers and conveyors are operated under negative pressure.

The vessel comprises a circular, partially water-cooled, steel shell containing refractories. Ash is introduced through vessel side ports close to the slag line of the molten bath. Any metal particles present in the ash migrate through the slag layer due to their higher density and form a metal pool in the bottom of the vessel beneath the slag. Slag continuously overflows from the vessel into a container of water or is collected in steel molds and allowed to cool. Metal is periodically tapped into refractory-lined containers, allowed to cool, and sold as scrap for recycling. To maintain a homogeneous product given variations in waste feed streams, bath temperatures are maintained in excess of 1500 degrees Celsius. The slag, with its chemically-bound elements, is environmentally safe and passes EPA standard tests for leachability.

A fume hood connected to the off-gas treatment system is provided over the tapping port to collect fugitive emissions. The off-gas from the vessel is mixed with an appropriate quantity of air and burned in a combustion chamber. Hot gases pass through duct work where the temperature is reduced to 150 degrees C by direct dilution with fresh cool air through dampers. Cooled gases pass through a packed bed scrubber where neutralized water is added to remove acids. This is followed by a fabric filter baghouse where the cleaned gas exits to a stack through a variable speed induced draft fan. The entire system is fully instrumented to monitor all aspects of the operation. NOx generated during the process can be reduced to acceptable levels by operating under a reducing atmosphere either by addition of carbon or hydrogen in the form of ammonia injection. This gas is subjected to temperature control and then particulate control, resulting in a clean gas discharge with little or no environmental impact.

Finished products are all solid materials. The slag is mainly a silica and lime compound incorporating some chemically-bound impurities which can be used as aggregate or other applications since it is environmentally safe. The Japanese have developed various end products or commodities with the glassy slag such as water-permeable brick, tile for sidewalks and residential uses, architectural structures for parks and other sites, pottery, and retainer walls. The valuable byproducts make the process more economically attractive and competitive.

6.0 Department of Defense Plasma Arc Demonstration Projects

In the early 1990's the Army and Navy began investigating the possibility of utilizing thermal plasma technology to address some of their waste problems. The Army is investigating the adaptation of thermal plasma technology to address the safe, long term remediation of asbestos, hazardous waste, and chemical weapons, and demilitarization of ordnance. The Navy is investigating the adaptation of thermal plasma technology to treat naval facility industrial hazardous waste. Both services are using full-scale demonstration projects to determine if a larger investment in thermal plasma technology is feasible.

The three current Army projects which are highlighted include (1) Plasma Ordnance Disposal System, (2) Plasma Energy Pyrolysis System Demonstration Project, and (3) MSE-TA Mobile Plasma Treatment System. The Navy project which is highlighted is the Naval Base Norfolk Plasma Arc Hazardous Waste Treatment Facility.

6.1 Plasma Ordnance Disposal System –

The Armament Systems Process Division of the US Army's Tank, Automotive and Armaments Command – Armament Research, Development and Engineering Center, with direction from the US Army Defense Ammunition Center, is executing a project to develop plasma arc technology for the demilitarization of completely assembled, small caliber and hand emplaced, smoke and pyrotechnic ordnance. This effort was initiated to find an alternative to the historical method of demilitarization for these items which has been open burning/open detonation. For smoke munitions in particular, the Surgeon General issued a moratorium on open burning due to the potentially carcinogenic nature of the combustion products. Plasma arc technology was selected for development because of several benefits that it offered. The process encapsulates regulated hazardous constituents of feed ordnance into a solid, low-leachable, homogeneous, waste form which passes the Environmental Protection Agency's (EPA's) criteria for a nonhazardous waste. In addition, the process promised a clean off gas complying with emission regulations. Finally, the technology offered the potential benefit of demilitarizing completely assembled, small sized end items without requiring prior disassembly.

A test program was carried out from 1992 – 1996 at the Western Environmental Technology Office in Butte, MT. This facility is operated by MSE – Technology Applications, Inc. (MSE-TA). It was originally a Department of Energy Owned Facility but has recently been privatized. The objective of this testing was to evaluate the feasibility of plasma arc technology and optimize the process for ordnance demilitarization. A total of 19 different live items were processed over a series of test campaigns at rates up to 250 pounds per hour. The testing demonstrated the suitability of plasma arc technology for ordnance demilitarization, provided operational data, and identified critical design parameters for design of a full scale, production system.

Between 1996 – 1998, conceptual and detailed designs were developed by MSE-TA for a prototype system specifically tailored for ordnance demilitarization. This system has been named the Plasma Ordnance Demilitarization System (PODS). The system is designed to nominally process 425 – 525 pounds per hour of ordnance, although higher throughputs are anticipated for a number of ordnance items. The primary process chamber consists of an enclosed chamber containing a fixed hearth and will operate in an oxidizing environment. Oxygen will be injected to assure good oxidation of organic compounds. It will be equipped with both transferred and non-transferred arc torches to accommodate different processing needs. Soil will be added to the process to provide the molten bath in which the ordnance will be introduced and react and also to provide the matrix forming elements that encapsulate hazardous metals into the final non-hazardous form. Iron will also be added to flux the melt which is sometimes required for good slag production. The soil and metal combined additive will be fed at a ratio of approximately 50/50 to the ordnance. The system will be equipped with a state-of-the-art pollution abatement train. This will include a diesel fired secondary combustion chamber, wet quencher, acid gas scrubber, wet particulate scrubber, bag house, and a NOx removal unit. The entire system is maintained at a slight vacuum by an induced draft fan. This would prevent any process gases from escaping in the event of a leak in the system.

All system equipment was either procured or has been fabricated in-house by MSE-TA during 1998. The primary chamber was manufactured by MSE-TA and is scheduled for a factory acceptance test during the end of calendar year 1998.

The system will be installed at Hawthorne Army Depot, Hawthorne, NV. The focus of the technology will be the demilitarization of smoke and pyrotechnic munitions; however, other ordnance items will also be addressed. All items planned for processing are small in size. These items include simulators, tear gas containing devices, propellant and cartridge activated devices such as airplane canopy emergency releases, incendiary munitions, fuzes, ignition and propellant cartridges, and munition components containing small amounts of high explosives.

Environmental permits are currently being sought for the PODS. These include an air permit, a Resource Conservation and Recovery Act (RCRA) permit, and a National Pollutant Discharge Elimination System (NPDES) water permit. The system cannot be installed until these permits are obtained and the permitting is the critical path for the project. The system is being permitted as an incinerator under RCRA, primarily due to the diesel fired secondary combustion chamber which classifies it as an incinerator by the Code of Federal Regulations. The schedule for environmental permitting is difficult to predict. It is expected, however, that the permits should be obtained around the fourth quarter of FY00. The system will then be installed and debugged and a trial burn conducted around the first quarter of FY02. Upon successful completion of the trial burn, a full operating permit will be granted and full scale demilitarization operations will be initiated.

6.2 Naval Base Norfolk Plasma Arc Hazardous Waste Treatment Facility –

In 1995 a project was awarded to the Naval Research Laboratory and Norfolk Naval Base under the Department of Defense Environmental Security Technology Certification Program (ESTCP) with the objective of establishing a demonstration plasma arc hazardous waste treatment facility (PAHWTF) at the Naval Base that would be capable of destroying both solid and liquid waste on a production basis and obtaining operational data necessary to determine the cost effectiveness of the process. Activities at the Naval Base annually generate 3 million pounds of industrial waste, both hazardous and non-hazardous. Significant components of the waste stream include used paint, cleaning rags, cleaning compounds, solvents, and other chemicals used in industrial operations. The cost of disposing of this waste are significant and are currently over \$4 million annually, representing an average of \$1.50 per pound, [77].

The PAHWTF is currently under construction at Retech, a Division of Lockheed Martin Advanced Environmental Systems. It is designed to treat a minimum of 600 pounds per hour of inorganic waste and 450 pounds per hour of organic waste. It contains both a solids and liquid feeder, a primary processing chamber containing an 8-foot-diameter rotating crucible and a 750 kW- transferred DC plasma torch, a secondary treatment chamber containing a 750 kW non-transferred DC plasma torch, a slag collection chamber, and an offgas treatment system consisting of a water quench, a baghouse, a wet scrubber, a reheater and an induced draft fan. Figure 4 is a schematic of the entire system. When construction is completed, a factory inspection test will be conducted at Retech in the Spring of 1999 in which the PAHWTF will treat paint, oily rags, and a chlorinated solvent in two separate three-hour runs at the specified feed rate. Emissions will be measured through acquisition of grab samples in accordance with standard EPA protocols and through the use of continuous emissions monitors.

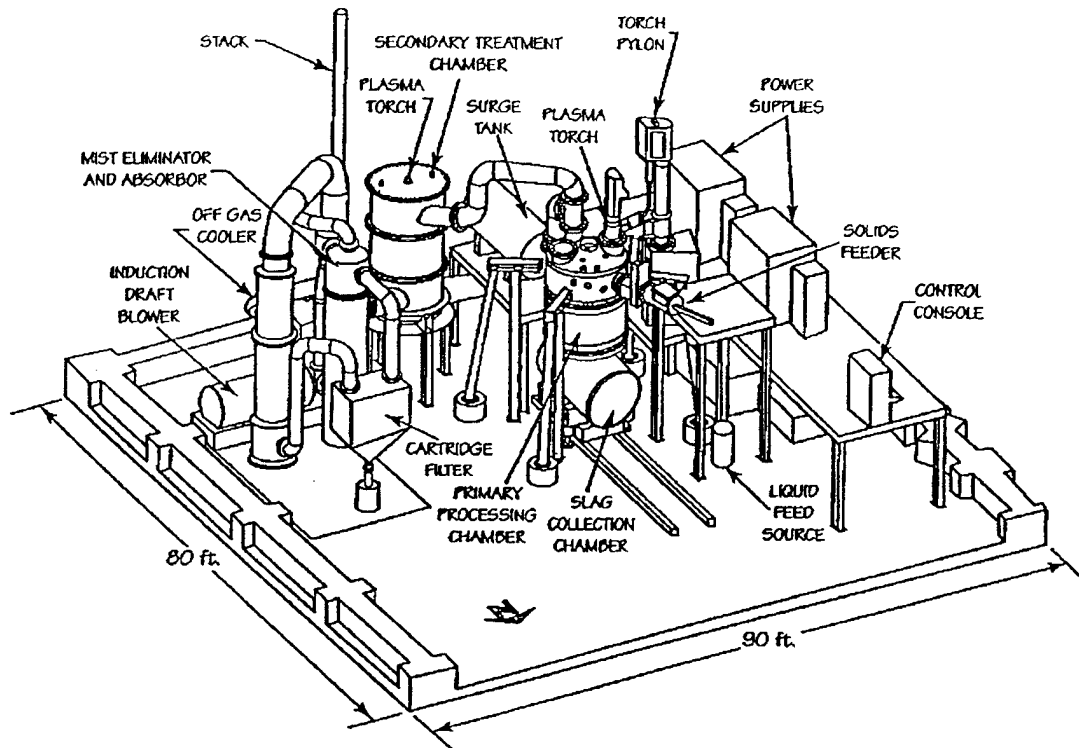

Figure 4: Schematic of the Naval Base Norfolk Plasma Arc Hazardous Waste Treatment Facility

The system is expected to be installed and tested at the Naval Base in early 2000. The PAHWTF would initially be operated under the ESTCP Program as a demonstration facility to demonstrate the complete destruction of solid and liquid hazardous wastes on a production basis. Because of the anticipated large amount of time required to obtain a Resource Conservation and Recovery Act (RCRA) Part B permit for operation of the PAHWTF as a full production facility, it was decided to initially pursue a RCRA research, development, and demonstration (RD&D) permit and subsequently submit a permit application for full operation. A permit for operation of the PAHWTF under the Clean Air Act will also have to be obtained. The unit will be expected to meet the maximum achievable control technology (MACT) emissions standards [77].

6.3 Plasma Energy Pyrolysis System Demonstration Project -

In Fall 1997, under a Congressional directive, the United States Army Environmental Center (USAEC) in cooperation with the Tennessee Valley Authority (TVA) started a program to design, install, demonstrate, and deactivate a transportable Plasma Energy Pyrolysis System (PEPS) capable of destroying at least two selected United States Department of Defense (USDOD) waste streams. The waste streams that have been selected are medical waste and paint blast media. Assisting USAEC and TVA in this effort as prime contractor is Vanguard Research, Inc. (VRI). VRI has teamed with PEAT, Inc. of Huntsville, AL, the developer of the technology, to design and build the transportable PEPS.

The PEPS demonstration facility was assembled and installed during the summer of 1998 in Lorton, VA. The demonstration test period will last 200 hours for each waste stream, after which the transportable PEPS may be used for further testing and processing of additional USDOD problematic waste streams. The PEPS Demonstration Project is expected to validate the following objectives:

- Minimize or eliminate pre-processing of the waste
- Effectively destroy the selected waste streams
- Comply with air emission standards
- Minimize or eliminate landfill disposal

The anticipated maximum waste-processing rate will be 500 lbs./hr. VRI has received the following permits related to the installation and operation of the system.

- Solid Waste Permit-by-Rule for Regulated Medical Waste
- Air Permit
- Hazardous Waste Permit Exclusion for Treatability Study

In addition, the PEPS also conforms to all local zoning, wastewater, and fire & rescue ordinances.

In March 1998 the USAEC issued an environmental assessment and in May 1998 issued a Finding of No Significant Impact for the PEPS Demonstration Program. The demonstration phase of the project was initiated in November 1998.

As a continuation of their evaluation of the Plasma Energy Pyrolysis System technology, the Army in July 1998 funded the design, development, testing, and evaluation of the PEPS technology in a mobile form, (designated PEPS II). The US Army Construction Engineering Research Laboratories (USACERL) is the lead Army agency for this project, and Concurrent Technologies Corporation (CTC) is the execution organization. Under this phase of the PEPS program, the system components will be mounted on vehicular trailers for road movement to waste sites, and for demonstrating waste processing and destruction at these sites. The mobile PEPS system to be developed by Vanguard Research, Inc. and PEAT, Inc. under this project will be smaller in size and waste processing capacity than the transportable PEPS in Lorton, VA. The design will also be capable of concurrently processing both solid and liquid wastes. The conceptual design of the Mobile PEPS has been completed, and USACERL and CTC scheduled its conceptual design review, for November 1998.

Waste processing demonstrations by the Mobile PEPS are planned at three USDOD waste sites during 1999 - 2000, to demonstrate the effective performance of PEPS versus current disposal methods. The sites and waste streams to be processed will be selected by the US Army, after which full demonstration permits will be obtained from the state and local authorities for the respective waste sites before the demonstrations commence. The typical military waste candidates for the PEPS process

may include thermal batteries, pyrotechnics, and similar small items and components. Waste material candidates may also include waste paints and solvents, spent blast media, and industrial sludges (e.g., electroplating sludge). The project provides an environmental compliance technology to reduce the cost of treatment and disposal of hazardous and toxic waste streams resulting from production or deactivation of military weapon systems or from military operations.

6.4 MSE-TA Mobile Plasma Treatment System –

The U.S. Army Corps of Engineers Construction Engineering Research Laboratory (USACERL), under the Industrial Waste Streams Pollution Prevention Program, has the mission of developing and fielding environmental compliance technologies to support the environmental stewardship goals and responsibilities of the U.S. Army and other government agencies. MSE Technology Applications, Inc., (MSE-TA) has proposed the Mobile Plasma Treatment System to help meet these goals.

In this project MSE will design and build an oxidative mobile plasma hazardous waste treatment system that is intended to be a technology demonstrator for pilot-scale mobile plasma waste processing. The system is expected to be capable of providing small-scale waste remediation services, and conducting waste stream applicability demonstrations.

The system will be designed to be operated as skid mounted modules; consisting of a furnace module, controls module, off-gas module, and ancillary systems module. The system will be integrated and capable of being operated from a single control station and will provide semi-continuous feeding and batch slag-pouring capability.

The design for the Mobile Plasma Treatment System is based on the heat and energy generated during treatment of a small energetic device (M676 Cartridge, 40-millimeter, canopy, yellow smoke ordnance device) that is representative of Cartridge Actuated Devices/Propellant Actuated Devices (CADs/PADs). The system is designed to process a feed rate of 50—125 lb./hr depending upon the source of supplemental oxygen, i.e., whether air or oxygen is used as the source of supplemental oxygen.

The Mobile Plasma Treatment System project consists of four main subtasks: design & build (currently in progress); factory acceptance testing(scheduled for September 1999); functional testing(scheduled for October through December 1999); and finally the demonstration testing(scheduled for January 2000 through September 2001).

7.0 Future Developments

Despite the enthusiasm displayed in the late 1980's and early 1990's by many people involved with thermal plasma technology, at present there are no fully permitted, production thermal plasma waste treatment systems in operation in the United States. In terms of assessing the future prospects for implementation of the technology in this area, it would be appropriate to separate hazardous or specialized (e.g., medical) wastes from standard municipal solid waste. The driving force for implementation will be relative cost. As an example, the current total cost for disposal of hazardous waste at the Norfolk Naval Base, which includes the cost for both in-house handling and outside contractors, averages \$1.50 per pound. It has been estimated that the thermal plasma system that will be installed at the base in the year 2000 will be able to process the hazardous waste for a total cost of \$0.80 per pound [77]. This cost will have to be verified through actual operation, but if it proves accurate, then thermal plasma technology will represent a viable and cost-effective means for large-scale hazardous waste generators to dispose of their waste on-site. For standard municipal solid waste (MSW), the story is different. At present that incinerator and landfill market has become overdeveloped, resulting in excess landfill capacity in the United States and many incinerators not operating at full capacity. Thus, the total cost of disposal of MSW ranges from only \$0.02 to \$0.04 per pound. There have been numerous estimates of the cost of processing standard MSW using thermal plasma technology, but they all range from \$0.20 to \$0.40 per pound. Therefore, it is highly unlikely that thermal plasma technology will be viable for treatment of MSW anytime in the near future.

While not discussed in detail in this report, the U.S. Department of Energy has funded considerable work in investigating the application of thermal plasma to remediating the large amounts of nuclear wastes. The decision to use or not to use thermal plasma technology for nuclear waste remediation has yet to be finalized and any discussion is outside the scope of this report. As shown in this report, within the Department of Defense, there are considerable non-nuclear hazardous wastes that can be treated successfully by thermal plasma technology, and efforts are underway to demonstrate this in a competitive environment. The ultimate decision to use thermal plasma technology for treating these wastes will be based on the demonstration programs presented in this report.

In late 1998, the Navy is initiating a three-year project to develop a prototype shipboard plasma arc waste treatment system. For the application of thermal plasma technology to treating shipboard waste, the Navy has had to abandon "conventional" thermal plasma waste processing and concentrate on the development of a compact and effective treatment process. The adaptation of the Navy's development project to the processing of liquid and gaseous hazardous wastes remains a possibility for the future. This abandonment of conventional processing concepts may lead to future utilization of

thermal plasma waste processing in areas where the economy of operation is clearly in favor of thermal plasma.

Thermal plasma technology has a lot to offer the waste processing community. While it is unlikely that thermal plasma will ever replace incinerators, the technology may be integrated into conventional treatment operations. More research needs to be conducted to increase the energy efficiency and economy of operation before the technology can become economically attractive. While some test results have been very impressive, the energy efficiency of thermal plasma waste processing system has not been optimized.

Additional research needs to be conducted to address several problems, such as electrode erosion, energy efficiency, process optimization, and total system integration. The technology is mature and improving in areas such as plasma cutting, ore processing, chemical synthesis, and plasma spray. In other areas, the technology still requires further development before it can economically be applied to many specific waste processing areas.

8.0 Conclusions

Thermal plasma technology has been very successful in ore processing, metallurgical processing, and chemical synthesis industries. There has been and is expected to be continued slow market penetration of thermal plasma technology into the waste processing arena. With future regulations anticipated to become more stringent, the commercialization of thermal plasma technology should move forward at a steady, but slow pace. Thermal plasma technology should play a part in the development of new waste treatment processes.

9.0 Acknowledgments

The authors would like to thank:

- Mr. Calvin Wolf of Aerotherm Corporation and Dr. Joachim Heberlein of the University of Minnesota for sharing their wealth of knowledge in plasma torch development.
- Dr. Richard C. Eschenbach of the Retech Division of Lockheed Martin Advanced Environmental Systems for the information concerning the Muttentz, Switzerland MGC Plasma system.
- Mr. Louis Kanaras of the U.S. Army Environmental Center, Environmental Technology Division, Technology Demonstration and Transfer Branch for information concerning the Plasma Energy Pyrolysis System Demonstration Project.
- Mr. Gary Mescavage of the U.S. Army Armament Research, Development and Engineering Center, Armament Systems Process Division for information concerning the Plasma Ordnance Disposal System.
- Drs. Ed D. Smith and Hany Zaghoul of the US Army Corps of Engineers, Construction Engineering Research Laboratory (USACERL), Champaign, IL for information concerning the Plasma Energy Pyrolysis System Demonstration Project and the MSE Mobile System.

10.0 References

1. Camacho, Salvador L., Refuse Converting Method and Apparatus Utilizing Long Arc Column Forming Plasma Torches, U.S. Patent Number 3779182, 1973
2. Camacho, Salvador L., and Louis J. Circeo, Jr. Apparatus and Method for the Recovery of Fuel Products from Subterranean Deposits of Carbonaceous Matter Using a Plasma Arc, U.S. Patent Number 4067390, 1978
3. International Union for Electroheat, Plasma Technology for a Better Environment, France: Plasma Technology Working Group, 1992
4. Vavruska, John S., Induction Steam Plasma Torch for Generating a Steam Plasma for Treating a Feed Slurry, U.S. Patent Number 5611947, 1997
5. Bitler, John A., and John P. Baranski., Process for Remediation of Lead-Contaminated Soil and Waste Battery, U.S. Patent Number 5284504, 1994
6. Carter, George W., and Andreas Tsangaris., Municipal Solid Waste Disposal Process, U.S. Patent Number 5280757, 1994
7. Kulkarni, Prabhakar., Method for Treatment of Hazardous Waste in Absence of Oxygen, U.S. Patent Number 5138959, 1992
8. Camacho, Salvador L., Plasma Pyrolysis and Vitrification of Municipal Waste, U.S. Patent Number 5544597, 1996
9. Camacho, Salvador L., Method for Vitrification of Fine Particulate Matter and Products Produced Thereby, U.S. Patent Number 5399833, 1995
10. Hedberg, Gorand J., and Ellen E. Knights., Destruction of Hydrocarbon Material, U.S. Patent Number 5484978, 1996
11. Camacho, Salvador L., Apparatus for Vitrification of Fine Particulate Matter, U.S. Patent Number 5497710, 1996
12. Camacho, Salvador L., Process for Plasma Pyrolysis and Vitrification of Municipal Waste, U.S. Patent Number 5634414, 1997
13. Cline, George H., Dale C. Edward, Bob G. Langberg, and Kurt G. Winkler., Method and System for Incineration and Detoxification of Semiliquid Waste, U.S. Patent Number 4989522, 1991

14. Pineau, Didier, M.J.M., and Yves H.G. Valy., Method for the Destruction of Chemically Stable Waste., U.S. Patent Number 4980092, 1990
15. Camacho, Salvador L., Refuse Converting Apparatus using a Plasma Torch., U.S. Patent Number 5143000, 1992
16. Wong, Alfred Y. and Andras Kuthi., Electrodeless Plasma Torch Apparatus and Methods for the Dissociation of Hazardous Waste., U.S. Patent Number 5288969, 1994
17. Dighe, Shyam V., and Charles B. Wolf., Plasma Fired Feed Nozzle., U.S. Patent Number 4761793, 1988
18. McLaughlin, David F., Shyam V. Dighe, and William R. Gass., Plasma Vitrification of Waste Materials., U.S. Patent Number 5637127, 1997
19. Chang, Kuo-Ching, Shin-Tsung Tseng, and Jain-Sheng Huang., Plasma Torch-Jet Liquid Waste Treatment Device., U.S. Patent Number 5363781, 1994
20. Bell, Christy W., Charles H. Titus, and John K. Wittle., Apparatus for the Decomposition of Hazardous Material and the Like., U.S. Patent Number 4431612, 1984
21. Wulff, Heinrich., Process and Equipment for the Treatment of a Material by Means of an Arc Discharge Plasma., U.S. Patent Number 3852061, 1974
22. Tylko, Jozef K., Treatment of Matter in Low Temperature Plasmas., U.S. Patent Number 4361441, 1982
23. Schlienger, Max. P., Apparatus and Method for High Temperature Disposal of Hazardous Waste Materials., U.S. Patent Number 4770109, 1988
24. Schlienger, Max P., Apparatus for High Temperature Disposal of Hazardous Waste Materials., U.S. Patent Number 5136137, 1992
25. Kolak, Nicholas P., Thomas G. Barton, Chun C. Lee, and Edward F. Peduto, Trial Burns - Plasma Arc Technology., Nuclear and Chemical Waste Management, Vol. 7, pp 37-41, 1987
26. Gollands, Mark, Edward Peduto, Joanna Hall, and Howard Schiff, Stack Testing of the Mobile Plasma Arc Unit., Publication EPA/600/S2-87/013, 1987
27. Section 1003, Public Law 103-160, National Defense Authorization Act for Fiscal Year 1994.

28. Gross, Boleslav, Bronislav Geczy, and Konstantin Miklossy, Eds. Plasma Technology, Trans. Zdenek Rudinger. London: Iliffe Books Ltd, 1968
29. Feinman, Jerome, Ed. Plasma Technology in Metallurgical Processing, Warrendale, PA: Iron and Steel Society, 1987
30. Roth, J. Reece., Industrial Plasma Engineering. Volume 1: Principles, London: Institute of Physics, 1995
31. Raizer, Yuri P., Gas Discharge Physics, New York: Springer-Verlag, 1987
32. Mac Rae, D.R., Plasma Arc Process Systems, Reactors, and Applications, Plasma Chemistry and Plasma Processing, Vol. 9, No. 1, 1989, (Supplement)
33. Simmons, Orien W., Electric Arc Melting Furnace, U.S. Patent Number 2652440, 1953
34. Kane, J.S., and Peter R. Schaefer, Pressure Retractable Arc Torch, U.S. Patent Number 3242305, 1966
35. Gage, Robert M., Arc Torch Process with Reactive Gases, U.S. Patent Number 2862099, 1958
36. Gauvin, W. H., Some Characteristics of Transferred-Arc Plasmas, Plasma Chemistry and Plasma Processing, Vol. 9, No. 1, 1989 (Supplement)
37. Eschenbach, Richard C., Method for Heating Gases, U.S. Patent Number 3294952, 1966
38. Hanus, Gary J., Todd J. Stahl, and Salvador L. Camacho, Convertible Plasma Arc Torch and Method of Use, U.S. Patent Number 5362939, 1994
39. Sakuragi, Shunichi, and Naoya Tsurumaki, Plasma Torch Having Cylindrical Velocity Reduction Space Between Electrode End and Nozzle Orifice, U.S. Patent Number 5591356, 1997
40. Camacho, Salvador L. and David P. Camacho, Plasma Arc Torch, U.S. Patent Number 4587397, 1986
41. Camacho, Salvador L., Plasma Arc Heating Apparatus and Method, U.S. Patent Number 469446, 1987
42. Manabe, Tosikatu, Tetsuo Gejyo, and Yasuzi Hamura, Plasma Torch, U.S. Patent Number 3614376, 1971

43. Schlienger, Max P., Rotatable Plasma Torch., U.S. Patent Number 4912296, 1990
44. Schoumaker, Henry R.P.J., Plasma Curtain of Two or More Plasmas., U.S. Patent Number 3786306, 1974
45. Tsantrizos, Peter, Raynald Lachance, Bruce Hehshaw, and Lakis T. Mavropoulos, High Enthalpy Plasma Torch., U.S. Patent Number 5147998, 1992
46. Ivanov, Vladimir, Pavel P. Kulik, and Alexis N. Logoshin, Method of Control of Plasma Stream and Plasma Apparatus., U.S. Patent Number 5489820, 1996
47. Haun, Rob E., Neil C. Elmer, and Robin A. Lampson, Arc Plasma Torch Having Tapered-Bore Electrode., U.S. Patent Number 5239162, 1993
48. Wolf, Charles B., George A. Kemeny, and Serafino M. De Corso, Electrode for an Arc Furnace Having a Fluid Cooled Arcing Surface and a Continuously Moving Arc Thereon., U.S. Patent Number 3385987, 1968
49. Houseman, John, Solids Arc Reactor Method., U.S. Patent Number 3533756, 1970
50. Wolf, Charles B., and George A. Kemeny, Multiple Annular Electrode Gas Arc Heater with a Magnetic Arc Spinner., U.S. Patent Number 3309550, 1967
51. Wolf, Charles B., Shyam V. Dighe, Paul E. Marting, Raymond F. Taylor, Jr., and William J. Melilli, Plasma Torch with Extended Life Electrodes., U.S. Patent Number 5004888, 1991
52. Ramakrishnan, Subramania, Walter T. Oppenlander, Alan E. Mundy, and Ian M. Ogilvy, Electric Arc Reactor Having Upstream and Downstream Electrodes., U.S. Patent Number 5296672, 1994
53. Camacho, David P. and Salvador L. Camacho, Plasma Arc Bulk Air Heating Apparatus., U.S. Patent Number 4625092, 1986
54. Marhic, Gerard, Didier Schaff, and Francis Remy, Plasma Torches., U.S. Patent Number 4625094, 1986
55. Dyos, Gordon Thomas, Plasma Torches., U.S. Patent Number 3830428, 1974
56. Bebbler, Hans J., Heinrich-Otto Rossner, and Gebhard Tomalla, Plasma Torch with Hollow Fluid Cooled Nozzle., U.S. Patent Number 4645899, 1987
57. Wolf, Charles B., Thomas N. Meyer, Maurice G. Fey, and John E. Heidrich, High Power Arc Heater., U.S. Patent Number 4535225, 1985

58. Pasquini, Pierre, Maxime Labrot, Jean-Pierre Serrano, and Didier Pineau, Plasma Torch Having a Longitudinally Mobile Arc Root, and Process for Controlling the Displacement Thereof., U.S. Patent Number 4847466, 1989
59. Ponghis, Nikolas G., Electric Arc Plasma Torch., U.S. Patent Number 4596918, 1986
60. Brouet, Michel G., Method and Device for Controlling the Erosion of the Electrodes of a Plasma Torch., U.S. Patent Number 4683367, 1987
61. Labrot, Maxime, Didier Pineau, and Jean Feuillerat, Tubular Electrode for Plasma Torch and Plasma Torch Provided with such Electrodes., U.S. Patent Number 4891490, 1990
62. Labrot, Maxime, Didier Pineau, and Jean Feuillerat, Plasma Torch for Noncooled Injection of Plasmagene Gas., U.S. Patent Number 5262616, 1993
63. Wolf, Charles B., Maurice G. Fey, and Frederick A. Azinger, Jr., Arc Heater with Integral Fluid and Electrical Ducting and Quick Disconnect Facility., U.S. Patent Number 3832519, 1974
64. Labrot, Maxime, Serge G.R. Muller, Jean Feuillerat, and Patrick Lautissier, Plasma Torch Provided with an Electromagnetic Coil for Rotating Arc Feet., U.S. Patent Number 5132511, 1992
65. Pasquini, Pierre, and Jacques Nuns, Method for Equalizing Wear to Prolong the Lifespan of a Plasma Torch Electrode., U.S. Patent Number 5376768, 1994
66. Heberlein, Joachim V.R., and Maurice G. Fey, Magnetic Field Stabilized Transferred Arc Furnace., U.S. Patent Number 4495625, 1985
67. Bellan, Paul M., Method and Apparatus for Stabilizing Electric Furnace Arcs Using an Externally Applied Magnetic Field., U.S. Patent Number 4815097, 1989
68. Schlienger, Max P., Apparatus and Method for High Temperature Disposal of Hazardous Waste Material., U.S. Patent Number 5005494, 1991
69. Pfender, Emil. Personal interview. November 14, 1997
70. New York State., Impediments To The Implementation of Alternative Technologies., New York State Center For Hazardous Waste Management, Buffalo, New York, January 11-12, 1990
71. United States. General Accounting Office., Hazardous Waste: Remediation Waste Requirements can Increase the Time and Cost of Cleanups., Publication GAO/RCED-98-4. Washington: GPO, 1997

72. United States. General Accounting Office., Environmental Protection: EPA's and States' Efforts to "Reinvent" Environmental Regulation., Publication GAO/T-RCED-98-33. Washington: GPO, 1997
73. Funfschilling, M. R., and R.C. Eschenbach, A Plasma Centrifugal Furnance for Treating Hazardous Waste, MuttENZ, Switzerland., Presented at Electrotech 92, Montreal, Canada, 1992
74. Burkhard, R., W. Hoffelner, and R.C. Eschenbach., Recycling of Metals from Waste with Thermal Plasma., Presented at the 3rd European East-Waste Conference and Exhibition on Materials and Processes, Strasbourg, FR, 1992
75. Hoffelner, W., A. Chrubasik, R.C. Eschenbach, M.R. Funfschilling, and B. Pellaud, Plasma Technology for Rapid Oxidation, Melting, and Vitrification of Low/Medium Radioactive Waste., Nuclear Engineering International, October 1992
76. Hoffelner, W., Th. Muller, M.R. Funfschilling, A. Jacobi, R.C. Eschenbach, H.R. Lutz, and C. Vuilleumier, New Incineration and Melting Facility for Treatment of Low Level Radioactive Wastes in Switzerland., Presented at the 1994 Incineration Conference, Houston, TX, 1994
77. Sartwell, Bruce D. Development of a Plasma Arc System for the Destruction of U.S. Department of Defense Hazardous Waste. Proceedings of the 1997 International Conference on Incineration and Thermal Treatment Technologies, Oakland, CA, 1997

Appendix A

List of U.S. Firms involved in Thermal Plasma Waste Treatment

The list below contains U.S. firms involved in thermal plasma waste treatment. Every effort was made to make this list comprehensive, but there may be companies of which the authors are not aware. This listing is provided for informational purposes only and no endorsement is implied.

Aerotherm Corporation
580 Clyde Avenue
Mountain View, CA 94043
Telephone - (415) 961-6100

Global Plasma Systems
1825 Eye St. N.W.
Suite 400
Washington, DC 20006
Telephone - (202)-429-2011

Meltran
2300 North Yellowstone Hwy
Suite 207
Idaho Falls, ID 83401
Telephone - (208)-524-6358

MSE-Technical Applications
PO Box 4078
Butte, MT 59702
Telephone - (406) 494-7412

Montec Associates, Inc.
PO Box 4182
Butte, MT 59702
Telephone - (406)-494-5555

PEAT, Inc.
4914 Moores Mill Road
Huntsville, AL 35811
Mail Code HP
Telephone - (205) 859-3006

PHOENIX Solutions Co.
5900 Olson Memorial Hwy.

Minneapolis, MN 55422
Telephone - (612) 544-2721

Plasma Energy Corporation
7516 Precision Drive
Raleigh, NC 27613
Telephone - (919)-598-3333

Plasma Pyrolysis Systems, Inc.
PO Box 158
Stuyvesant Falls, NY 12174
Telephone - (518)-828-4684

Plasma Technology Corp.
8601 Six Forks Road
Suite 400
Raleigh, NC 27615
Telephone - (919)-676-5304

Plasma Technology, Inc. of Santa Fe
2200 Brothers Road
Santa Fe, New Mexico 87505
Telephone - (505) 988-4943

Plasma Waste Conversion
3300 Jarrettsville Pike
Monkton, MD 2111
Telephone - (410)-557-7177

Retech Division
Lockheed Martin Advanced Environmental Systems
100 Henry Station Road
PO Box 997
Ukiah, CA 95482
Telephone - (707)-462-6522

Science Applied International Corporation
545 Shoup Avenue
Idaho Falls, ID 83402
Telephone - (208)-528-2144

Startech Environmental, Corp.
79 Old Ridgefield Rd.
Wilton, CT 06897
Telephone - (203) 762-2499

Vanguard Research Inc.
10400 Eaton Place
Suite 450
Fairfax, VA 22030-2201
Telephone - (703) 934-6300

Westinghouse Electric Company
Plasma Center
1310 Beulah Road
Pittsburgh, PA 15235
Telephone - (412)-256-2235