

REPORT DOCUMENTATION PAGE

Form Approved OMB No. 074-0188

Public reporting burden for this collection of information is estimated to average 1 hour per response, including the time for reviewing instructions, searching existing data sources, gathering and maintaining the data needed, and completing and reviewing this collection of information. Send comments regarding this burden estimate or any other aspect of this collection of information, including suggestions for reducing this burden to Washington Headquarters Services, Directorate for Information Operations and Reports, 1215 Jefferson Davis Highway, Suite 1204, Arlington, VA 22202-4302, and to the Office of Management and Budget, Paperwork Reduction Project (0704-0188), Washington, DC 20503

1. AGENCY USE ONLY (Leave blank)	2. REPORT DATE 1998	3. REPORT TYPE AND DATES COVERED Final Report	
4. TITLE AND SUBTITLE The Upgrade of COIL Facility in Lebedev Physical Institute (Samara Branch)		5. FUNDING NUMBERS F61775-98-WE051	
6. AUTHOR(S)			
7. PERFORMING ORGANIZATION NAME(S) AND ADDRESS(ES) P.N. Lebedev Physical Institute RAS Samara Branch Novo-Sadovaya Str. 221 Samara 443011, Russia		8. PERFORMING ORGANIZATION REPORT NUMBER	
9. SPONSORING / MONITORING AGENCY NAME(S) AND ADDRESS(ES) EOARD PSC 802 Box 14 FPO 09499-0200		10. SPONSORING / MONITORING AGENCY REPORT NUMBER SPC 98-4044	
11. SUPPLEMENTARY NOTES			
12a. DISTRIBUTION / AVAILABILITY STATEMENT Approved for public release; distribution is unlimited.		12b. DISTRIBUTION CODE	
13. ABSTRACT (Maximum 200 Words)			
14. SUBJECT TERMS Foreign Reports, EOARD		NUMBER OF PAGES 30	16. PRICE CODE
17. SECURITY CLASSIFICATION OF REPORT UNCLASSIFIED	18. SECURITY CLASSIFICATION OF THIS PAGE UNCLASSIFIED	19. SECURITY CLASSIFICATION OF ABSTRACT UNCLASSIFIED	20. LIMITATION OF ABSTRACT UL

**P.N. Lebedev Physical Institute RAS, Samara Branch,
Chemical and Electric-Discharge Laser Laboratory**

Novo-Sadovaya str., 221, Samara, 443011, Russia, Fax: (8462)-355-600, e-mail: <nikolaev@fian.samara.ru >;

FG1775-98-WE051

FINAL TECHNICAL REPORT

SPC 98-4044

1. The upgrade of COIL facility in Lebedev Physical Institute (Samara Branch)

The previous COIL facility in LPI (Samara Branch) consists of the jet type SOG operating at chlorine molar flow rate up to 20 mmole/s and 5 cm gain length supersonic COIL. Pumping system consists of two mechanical pumps 180 l/s capacity and 4 m³ vacuum receiver. The iodine generator is able to generate 0.5 mmole/s of the iodine vapor molar flow rate. The chlorine feeding system is able to generate up to 30 mmole/s of chlorine molar flow rate during 10s.

Several modifications have been made for COIL operation at higher chlorine flow rates (up to 100 mmole/s), at higher iodine flow rate (up to 2 mmole/s) and with He gas dilution:

- a) Two additional vacuum tanks 5 m³ have been installed and connected to the vacuum system. At present the total volume of three tanks for receiving of gas from COIL is 14 m³. It allows to operate with He dilution gas 10 sec or to operate with N₂ dilution gas during 30 sec.
- b) Two refrigerators have been bought and all needed equipment have been manufactured and connected to these refrigerators. At now it is able to prepare and to cool of 10 liters of BHP with KOH molarity up to 8M during several hours.
- c) The Cl₂ supply system has been modified. Now the JSOG is fed by gaseous Cl₂ from the plastic flexible envelope 20 L in volume. This plastic envelope is placed inside the hard PVC vessel for the safety. The pressure of Cl₂ inside the plastic envelope is 1 external atmosphere. The Cl₂ flow rate is metered by the calibrated orifice. It allows for us to increase Cl₂ flow rate up to 100 mmole/s (during ~7 s).
- d) The new iodine generator have been manufactured. The solid iodine placed inside the stainless steel vessel 1 L in volume. The walls of stainless steel vessel preheated up to 60C°. The surface of solid iodine is heated by halogen lamp for smooth changing of the iodine flow rate. It allows for us to increase the iodine flow rate up to 2 mmole/s.
- e) The advanced jet type SOG (Verti-JSOG) has been designed and manufactured. It was projected that this generator would be able to operate at 100 mmole/s of Cl₂ molar flow rate.
- f) The gain COIL length is 5 cm. In this case all results obtained with the advanced JSOG may be possible to compare with results obtained for 10 mmole/s of Cl₂ flow rate and with results obtained in another laboratories (Beer-Sheva, Kirtland)

The general picture of the new set-up is presented in Fig. 1.

2. Performance characterization of supersonic COIL with array of small nozzles

The rake type iodine injector was successfully used in the subsonic COIL and in the supersonic COIL. The small mixing scale parameter ($\sim 1\text{mm}$) allowed to use the small secondary and primary buffer gas flow rates to obtain good mixing. The array of the small plane nozzles tested in Lebedev Institute Samara Branch is presented in Fig 2. The direct and the reverse positions of the array were tested. In the reverse position the array of nozzles is analogous to the rake type injector with mixing of iodine in the transonic region of the primary flow.

The changes of nonequilibrium gas parameters and an energy losses in the nozzles for relaxing gases are determined well known parameter¹ $P_0 h / \text{tg}\theta$, where P_0 is stagnation pressure, h - throat height, θ - semiangle of a nozzle. This parameter is differ strongly for shown nozzles' positions.

We started our tests with the normal nozzles' position. The grid had 10 blades with length equaled 10mm, expansion ratio 2 (the maximal blade thickness was 2.5mm and throat heights $d=2.5\text{mm}$ also, throat area $A_p= 2.5 \text{ cm}^2$) and exit cross section $5 \times 1 \text{ cm}^2$. The each blade had $(5+5)=8$ orifices with inner diameter $D=0.7 \text{ mm}$ (total area $A_s=0.384 \text{ cm}^2$). The walls of the supersonic duct diverge at angle 8° . Chlorine flow rate m_c was approximately constant and equal to $(10 \pm 1) \text{ mmole/ sec}$ for all tests. BHP temperature was supported at -15° C . The total laser power was normalized to 10 mmole/sec and was determined from the relation: $P_{\text{total}}=10(T_1+T_2) P_{\text{out}} / (T_1 m_c)$, where P_{out} is out power through mirror with transmission T_1 (usually $T_1=0.8\%$; $T_2=0.18\%$). The mirrors' curvature was 5m, the distance between ones was 63cm.

The next parameters shall be varied: distance between grid nozzles and optical axis (55mm, 85mm, 110mm), secondary nitrogen flow rate (1.25mmole/sec; 2.5mmole/sec; 5.0mmole/sec; 7.5mmole/sec), primary nitrogen flow rate (0; 10mmole/sec; 20mmole/sec), primary nitrogen temperature (80° K or 290° K), iodine flow rate (optimization). Primary nitrogen was mixed with oxygen downstream JSOG.

For zero primary nitrogen molar flow rate the results are presented in fig.3.

FIG.1

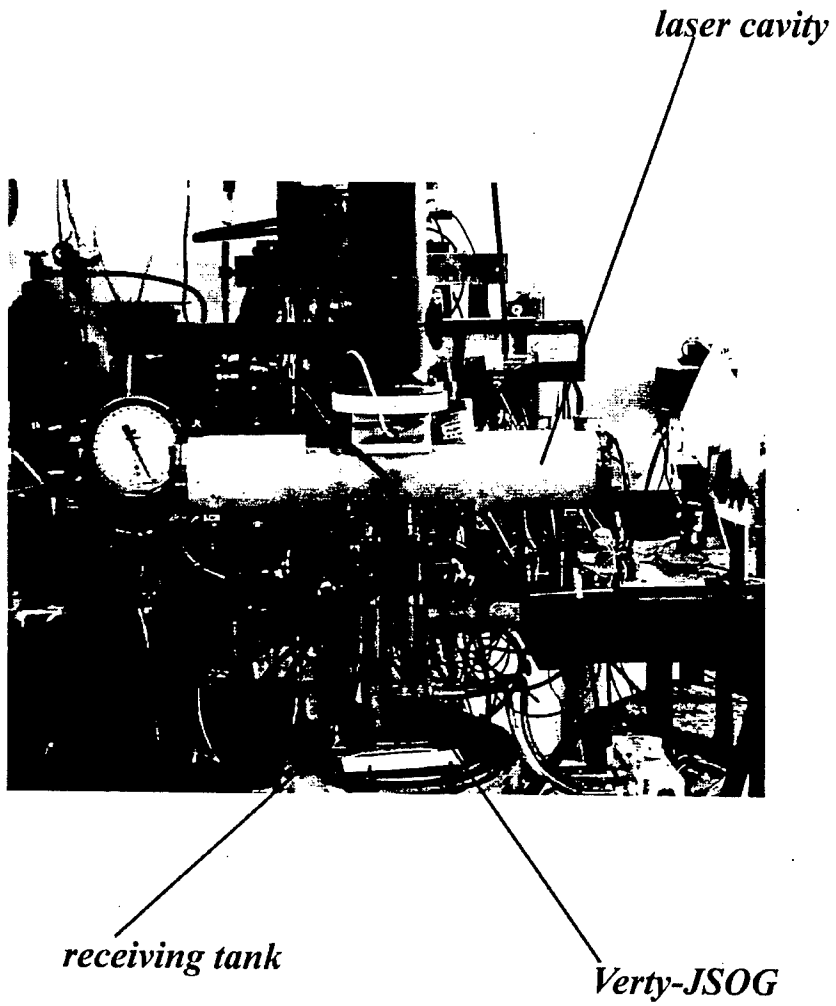

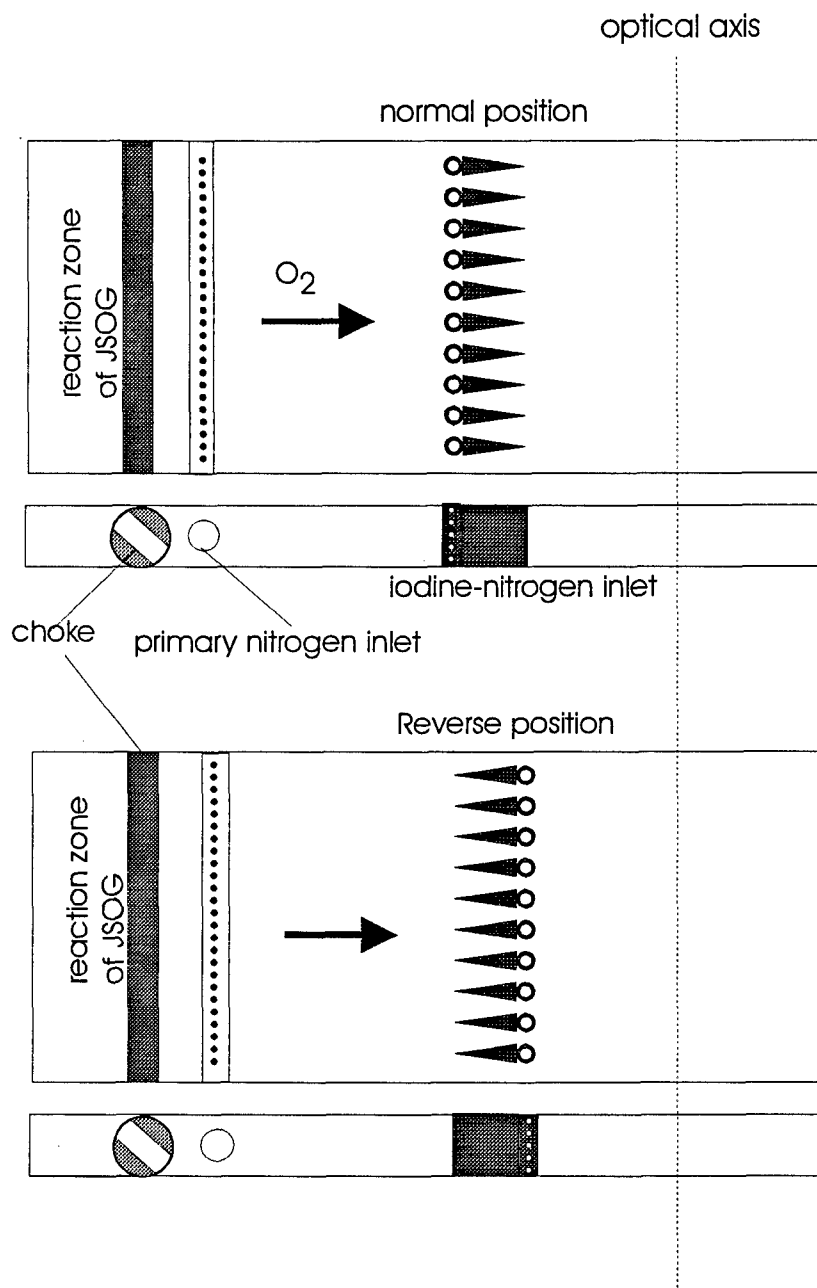

Fig.2

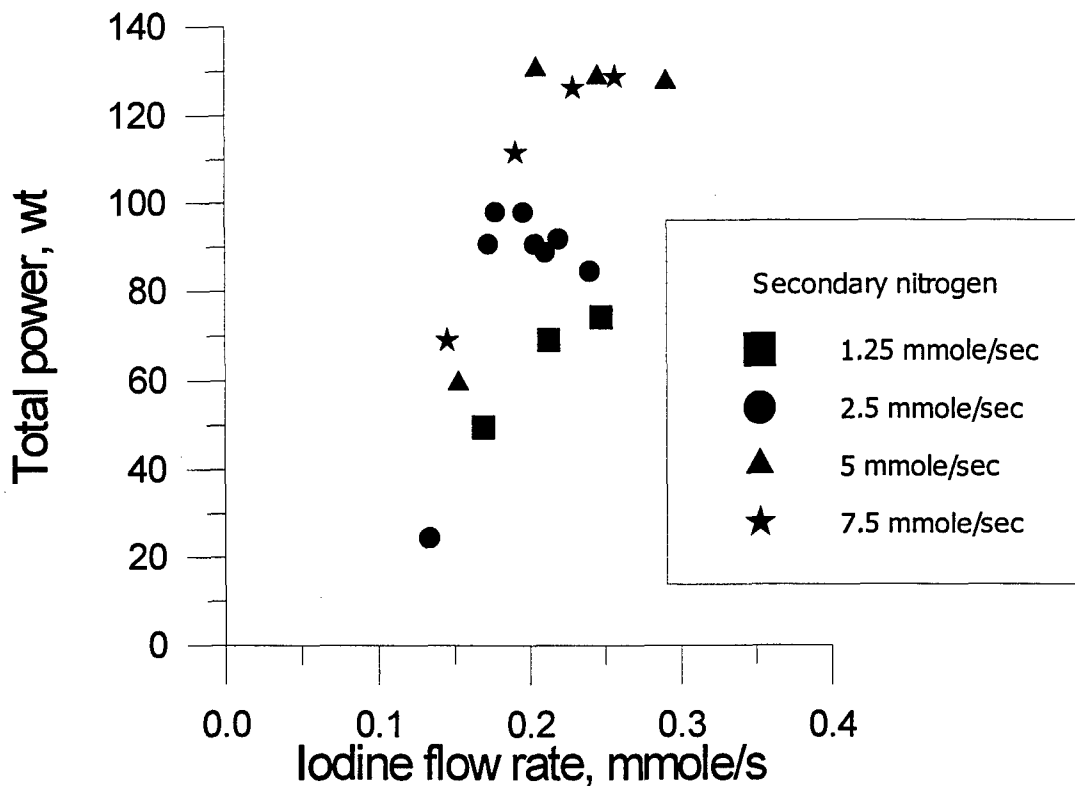

Fig. 3. COIL tests with small scale grid nozzles (normal position).

Chlorine flow rate - 10 mmole/sec

Primary nitrogen flow rate - 0 mmole/sec

BHP temperature is -15C

BHP injector -106orif. 0.8 mm, BHP=2.5lit (50%)H₂O₂+2.5lit(50%)KOH

The distance between grid nozzles and optical axis - 55 mm

The mirrors: T1=0.8%, T2=0.18%

The best results (chemical efficiency - 14%) have been obtained for the secondary nitrogen flow rate more 5 mmole/sec. Laser power decreased sharply with the reduction of the secondary nitrogen flow rate.

The results of experiments performed for 10mmole/sec of primary nitrogen at room temperature are presented in fig. 4. The best results (chemical efficiency - 16.3%) have been obtained for the secondary nitrogen flow rate 5 mmole/sec. The cooling of primary nitrogen to 80K did not increase the output power and we refused to test COIL with cold primary nitrogen further.

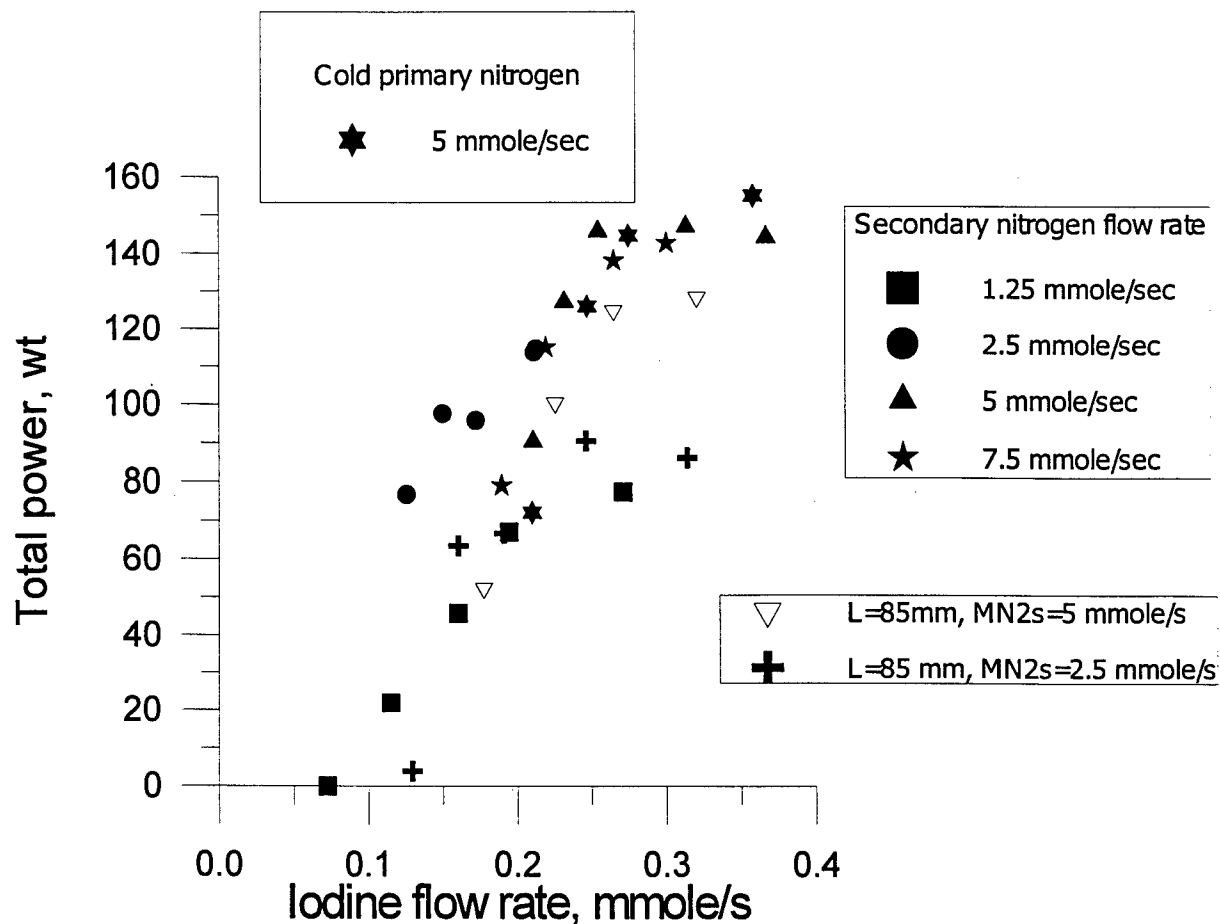

Fig. 4. The COIL tests with small scale grid nozzles, (normal position)
 Chlorine flow rate - 10 mmole/sec (10%)
 Primary nitrogen flow rate - 10 mmole/sec
 BHP temperature is -15C, primary nitrogen temperature 17C
 BHP injector-106orif., 0.8 MM,
 BHP=2.5lit (50%)H₂O₂+2.5lit(50%)KOH,
 The distance between grid nozzles and optical axis - L= 55 MM
 Mirrors: T1=0.8%, T2=0.18%

The results of experiments performed for 20 mmole/sec of primary nitrogen molar flow rate are presented in fig. 5. The best results have been received for 5mmole/sec of the secondary nitrogen flow rate. The maximal chemical efficiency 15.5% obtained for 20 mmole/s of primary N₂ is slightly less than efficiency 16.3% obtained for 10 mmole/sec of primary nitrogen molar flow rate. The decreasing of the chemical efficiency with increasing of primary nitrogen flow rate from 10 mmole/s to 20mmole/sec can be due to the increasing of the plenum pressure and higher O₂(¹Δ) losses in the duct between SOG outlet and primary nitrogen injector. Indeed, iodine jets block the throat cross section area that results in the increasing of the plenum pressure which is equal to 6.5 torr, 10torr and 13.5 torr for 0, 10mmole/sec and 20mmole/sec of the primary nitrogen flow rate respectively and 5mmole/sec of secondary buffer gas. The last results allow to stop further COIL investigations for the primary nitrogen flow rate more than 20mmole/sec. The tests at distance L=85 mm between grid nozzles and optical axis we made for primary buffer gas 10 mmole/sec only. The

results of these experiments are presented in fig. 4. The increase of distance between array of nozzles and optical axis resulted in decreasing of the output power. Similar tendency kept for distance $L=110$ mm, when chemical efficiency accounted only 6.7% and 11% for the secondary nitrogen flow rate 5 mmole/sec and the primary buffer gas flow rate 0 and 10 mmole/sec respectively.

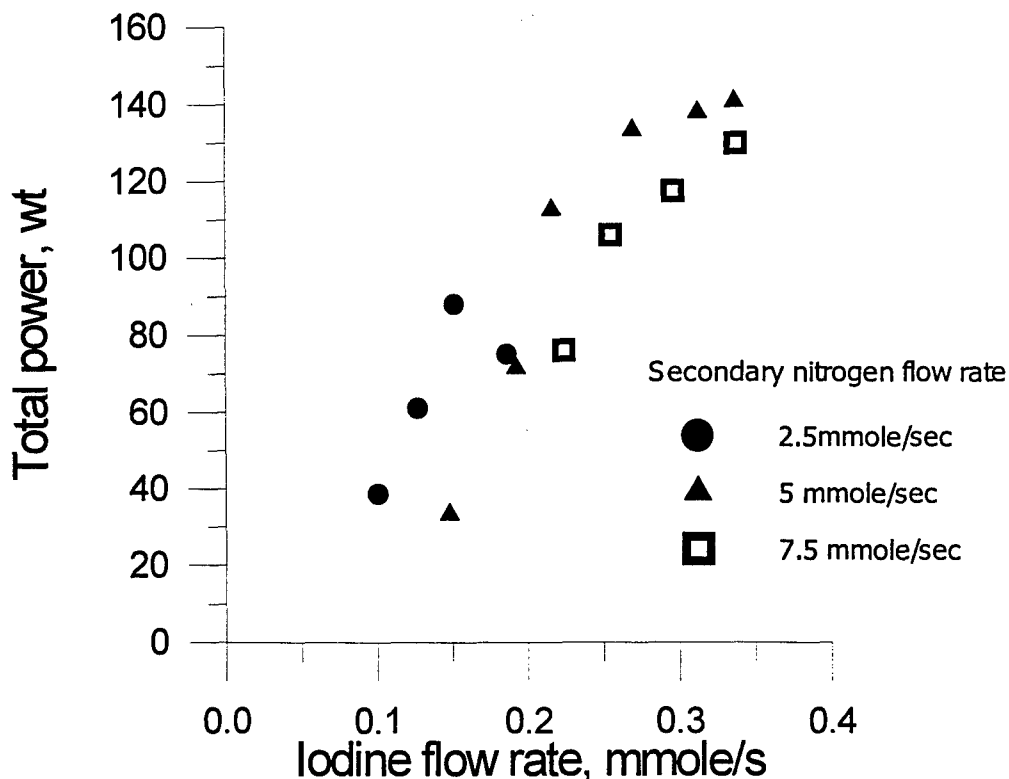

Fig. 5. The COIL tests with small scale grid nozzles, (normal position)
 Primary nitrogen flow rate - 20 mmole/sec
 BHP temperature is -15C
 BHP injector-106 orif. 0.8 mm, BHP=2.5lit (50%)H₂O₂+2.5lit(50%)KOH,
 The distance between grid nozzles and optical axis - 55 mm
 Mirrors: T₁=0.8%, T₂=0.18%

After completion these tests we turned grid nozzles on 180° and have repeated our experiments at new nozzles' position. The major results of these tests are presented in fig.6 and 7 and in the Table 1, where the COIL tests with fresh mirrors (T₁ = 1%, T₂ ≈ 0, in the table these tests marked off (*)) are presented also. The COIL efficiency is higher at reverse nozzle position when parameter $P_{oh}/tg\theta$ and contact time of the jets are smaller. The best results have been achieved for secondary nitrogen flow rate 5 mmole/sec, primary nitrogen flow rate 10mmole/sec and distance between grid and optical axis 85mm. The experiments with fresh Korean mirrors shown that the quality of mirrors plays very important role for small scale COIL. The Rigrod curve (fig. 8) obtained for the best working point shows that round trip gain is approximately 4.5% taking into account the estimation of nonresonant losses - 0.5%.

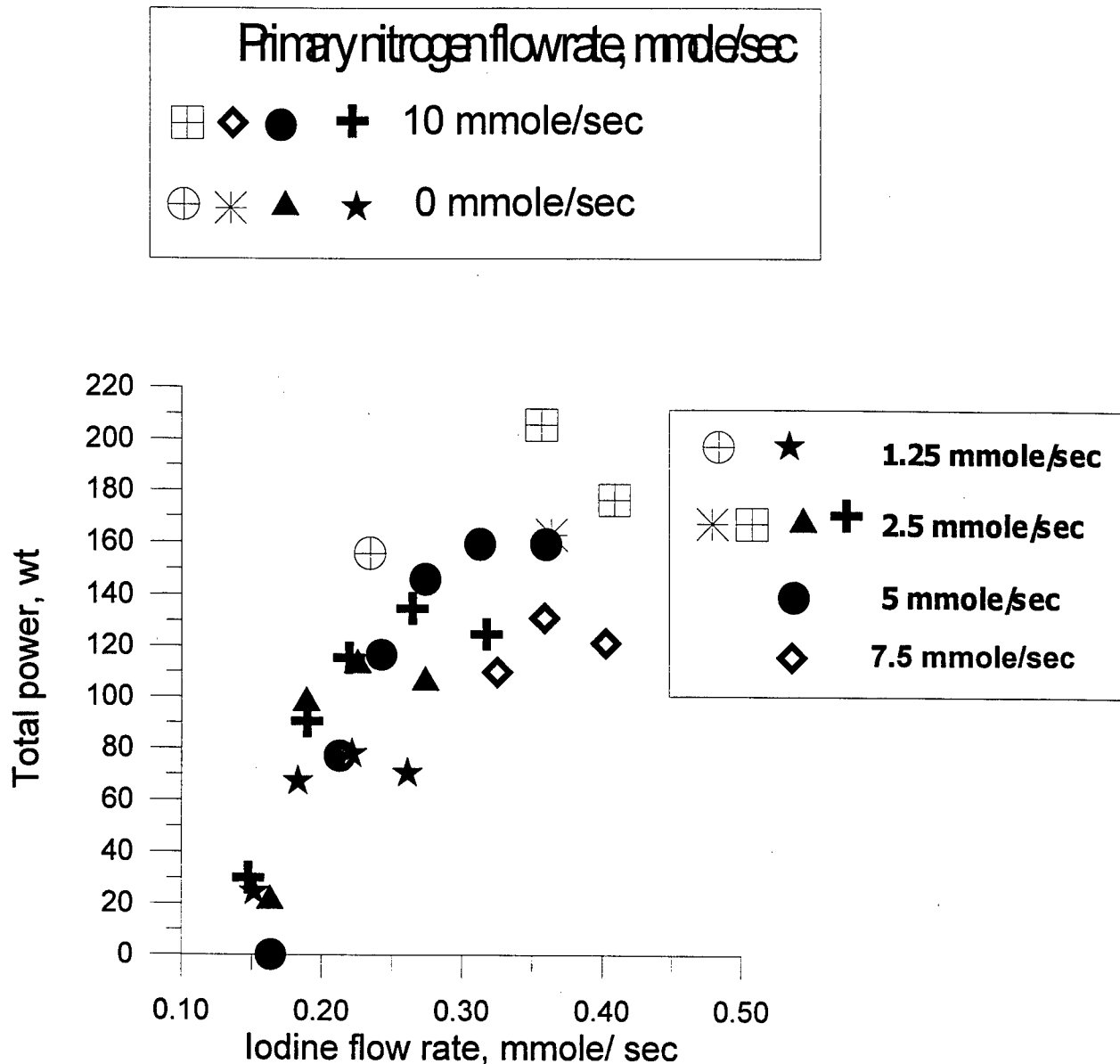

Fig.6. The COIL tests with reverse position of nozzles.

Chlorine flow rate - 10 mmole/sec
 BHP= 2.5lit (50%) H₂O₂+2.5lit (50%) KOH
 BHP temperature is -15C
 BHP injector - 106 orif., 0.8 mm
 The distance between grid nozzles and optical axis L= 85 mm
 Mirrors: T1=0.8%, T2=0.18%
 ✱ ⊞ ⊕ T1=1%, T2=0%

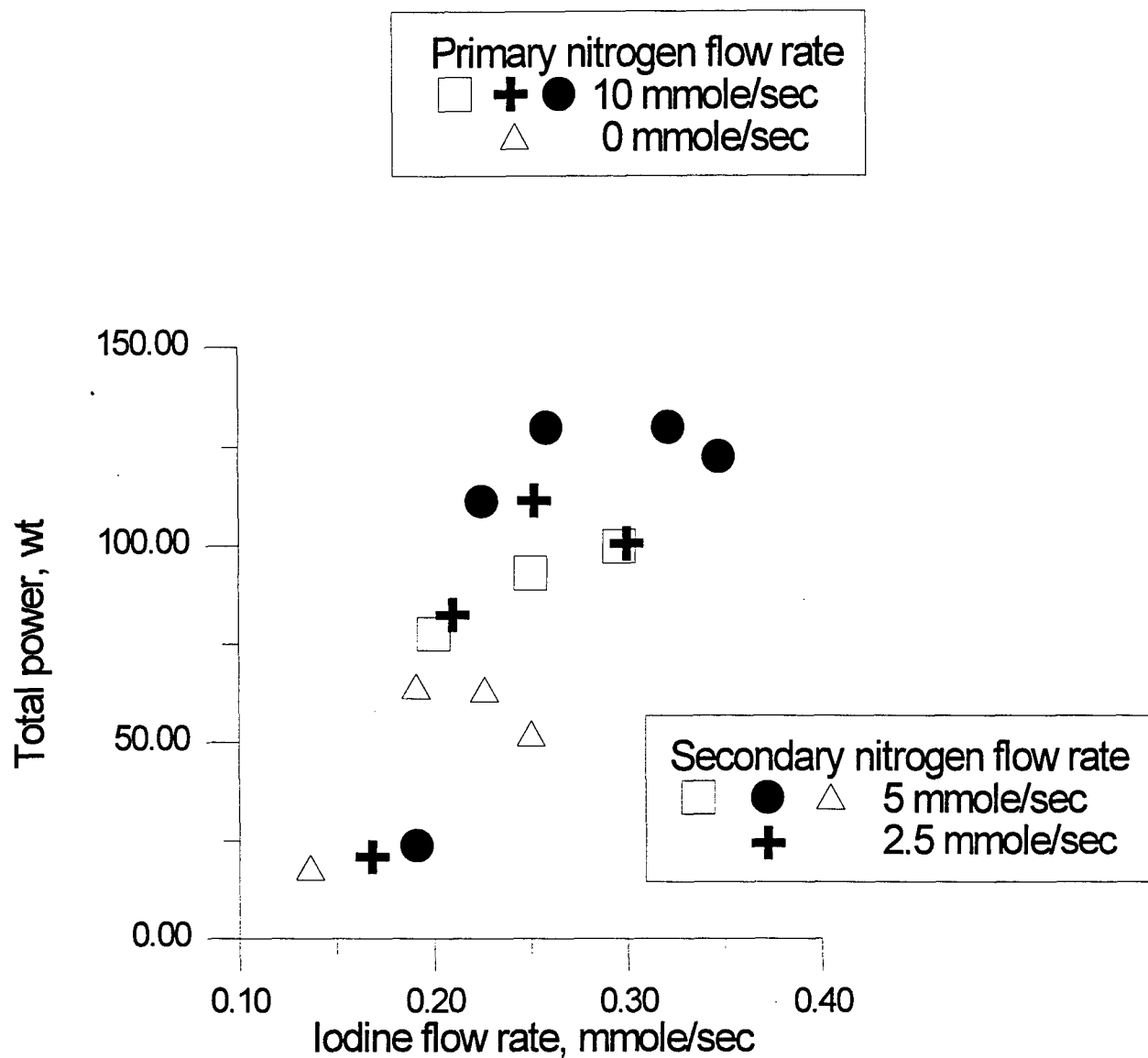

Fig.7. The Coil tests with small scale grid nozzles

△ □ - normal position, + ● - reverse position
 The distance between grid nozzles and optical axis - 110 mm
 Chlorine flow rate - 10 mmole/sec
 BHP temperature is -15C
 Mirrors: T1=0.8%, T2=0.18%
 BHP injector-106 orif., 08 mm,

Table 1. Maximal chemical efficiencies of COIL with array of small nozzles.
Iodine flow rate at which chemical efficiency reaches maximum presented in brackets.

$$T_1=0.8\%; T_2=0.18\%$$

1. Normal nozzles' position. The distance between iodine injector and optical axis is 55 mm.

N2 (secondary), mmole/sec	N2(primary), mmole/sec 0	N2(primary), mmole/sec 10	N2(primary), mmole/sec 20
1.25	8.2 (0.2-0.25)	8.6 (0.3)	-
2.5	10.1 (0.2)	12.7 (0.25)	9.7 (0.15?)
5.0	14 (0.2); *14.3 (0.27)	16.3 (0.3); *17.7(0.35)	15.5 (0.35)
7.5	14 (0.25)	15.8 (0.3); *15.9 (0.3)	14.3 (0.35); *13.4 (0.35)

2. Normal nozzles' position. The distance between iodine injector and optical axis is 85 mm.

N2 (secondary), mmole/sec	N2(primary), mmole/sec 0	N2(primary), mmole/sec 10	N2(primary), mmole/sec 20
1.25	-	-	-
2.5	-	10 (0.25)	-
5.0	-	14.2 (0.32); *17.7(0.34)	*13.8 (0.32)
7.5	-	*15.9 (0.31)	13.4 (0.33)

3. Normal nozzles' position. The distance between iodine injector and optical axis is 110 mm.

N2 (secondary), mmole/sec	N2(primary), mmole/sec 0	N2(primary), mmole/sec 10	N2(primary), mmole/sec 20
1.25	-	-	-
2.5	-	-	-
5.0	6.7 (0.28)	11 (0.37)	-
7.5	-	-	-

4. Reverse nozzles' position. The distance between iodine injector and optical axis is 55 mm.

N2 (secondary), mmole/sec	N2(primary), mmole/sec 0	N2(primary), mmole/sec 10	N2(primary), mmole/sec 20
1.25	-	-	-
2.5	-	-	-
5.0	-	14.4 (0.45); *19.1 (0.42)	-
7.5	-	13.8 (0.45); *18.8 (0.42)	-

5. Reverse nozzles' position. The distance between iodine injector and optical axis is 85 mm.

N2 (secondary), mmole/sec	N2(primary), mmole/sec 0	N2(primary), mmole/sec 10	N2(primary), mmole/sec 20
1.25	8.6 (0.22)	-	-
2.5	12.4 (0.23); *17.2 (0.23)	14.9 (0.26)	-
5.0	*18 (0.36)	17.6(0.35); *21.1 (0.37)	-
7.5	-	14.5 (0.35); *18.8 (0.42)	-

6. Reverse nozzles' position. The distance between iodine injector and optical axis is 110 mm.

N2 (secondary), mmole/sec	N2(primary), mmole/sec 0	N2(primary), mmole/sec 10	N2(primary), mmole/sec 20
1.25	-	-	-
2.5	-	12.3 (0.3)	-
5.0	7 (0.21-0.25)	14.3 (0.31-0.36)	-
7.5	-	-	-

(*) - $T_1=1\%$; $T_2=0\%$ ($R_2>99.9\%$). These mirrors have been manufactured in Republic Korea.

(-) this symbol in the cell means that test was not performed.

Gray cells show the working points with best results.

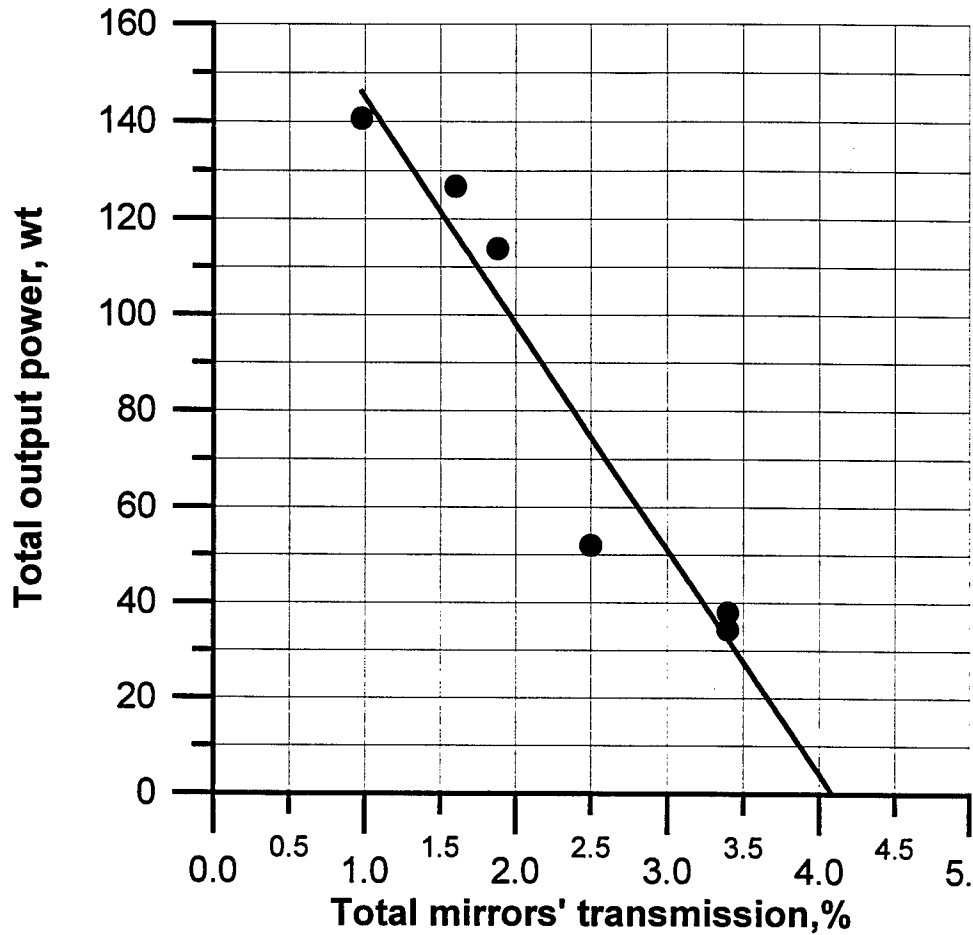

Fig.8. Output laser power dependence on total mirrors' transmittance for reverse small scall grid nozzles.

Primary N₂ flow rate - 10mmole/sec, secondary N₂ flow rate - 5mmole/sec, iodine flow rate -0.4mmole/sec, the distance between grid nozzles and optical axis - 85mm, temp(N₂)=300K.

The given experiments demonstrates the nice possibilities for creation not great COIL with small scale grid nozzles (chemical efficiency reached 21% for 10mmole/sec primary nitrogen and 18% - without primary nitrogen). The full penetration parameter² for our hardware was

$$\pi_{full} = dA_s / 5DA_p = 2.5 * 0.384 / (5 * 0.7 * 2.5) = 0.11$$

and it was difficult to realize the iodine injection into boundary layers because for the lowest secondary nitrogen flow rate 1.25 mmole/sec, iodine flow rate 0.2 mmole/sec and zero primary buffer gas penetration parameter was²

$$\pi = ((1.25 + 0.2) / 10) (59 \text{ g/mol} * 333^\circ * 6.7 \text{ torr}) / (32 \text{ g/mol} * 293^\circ * 8 \text{ torr}) = 0.192 >$$

π_{full}

It was found that the reverse nozzles' position gives the best COIL chemical efficiency. It can be due to using non-profiled nozzles' blade with the simplest wedge-shaped form. Such nozzles have more stretched region with high pressure than nozzles with angle point. We used in our experiments supersonic duct with the angle between wide walls equaled 8° . It is possible that this value is surplus for our condition and resulted in quick decreasing of the gas density downstream grid nozzles. Indeed, the cavity pressures at the absence primary buffer gas and for secondary nitrogen flow rate - 2.5 mmole/sec were 0.7 torr and 0.34 torr for $L=55\text{mm}$ and $L=85\text{mm}$ respectively. Plenum and Pito pressures and were 7.0-7.2 torr and 2 torr for both cases at these conditions. We didn't understand why using fresh mirrors gave the large increase of the chemical efficiency at reverse position and very small increase at the normal one. It is clear that the reverse nozzles' position and less value of angle between duct walls are needed for the up-graded COIL tests at high plenum pressure. After these test we may answer on the question of suitability of this method to powerful COIL.

REFERENCES

1. N.G. Basov, V.G. Mihailov, A.N. Oraevsky, V. A. Stcheglov, J. Technical Physics, **38**, (12), 2031-2041, 1968
2. J.E. Scott, J.L Shaw, K.A Truesdell, G.D. Hager, C.A Helms, AIAA Paper 94-2436, 1994

3. The ejector COIL scheme.

The stagnation pressure of exhaust COIL active medium can be increased by ejector scheme of mixing $\text{O}_2(^1\Delta)$ with $\text{N}_2 + \text{I}_2$ flow. An ejector operates by discharging a gas with a high stagnation pressure through nozzles into a low pressure stream and entraining it. The total stagnation pressure at the exit of COIL can be much more than the pressure in the reaction zone of JSOG. Using the ejector scheme with small dimension scale for preparing of the active medium with high stagnation pressure has important merit as compared to using ejector at COIL exit where dimension scale and weight of this device become much more. The nozzle system with one 1.5 mm oxygen slit and two (nitrogen + iodine) supersonic nozzles with 1mm throat and 4 mm exit height (see Fig. 9) is used for investigation jets' mixing and iodine dissociation. The total duct height was 10 mm at the nozzle system exit and expanded with total angle equal to 3° . The active length was 5cm. The duct height was 22mm at the distance equal 21 cm from nozzle where the optical axis is placed.

Our iodine generator gives possibility to operate with maximal nitrogen pressure in iodine cell equal to 490 torr (mass flow rate 0.27 mole/sec) for atmosphere pressure at the inlet of the nitrogen preheating tube. The static pressure equaled to 5.6 torr at the inlet of the mixing chamber and 3.2 torr at the optical axis position for the maximal nitrogen flow rate 0.27 mole/sec. It is interesting that green-yellow emission appeared at the distances which depend on nitrogen flow

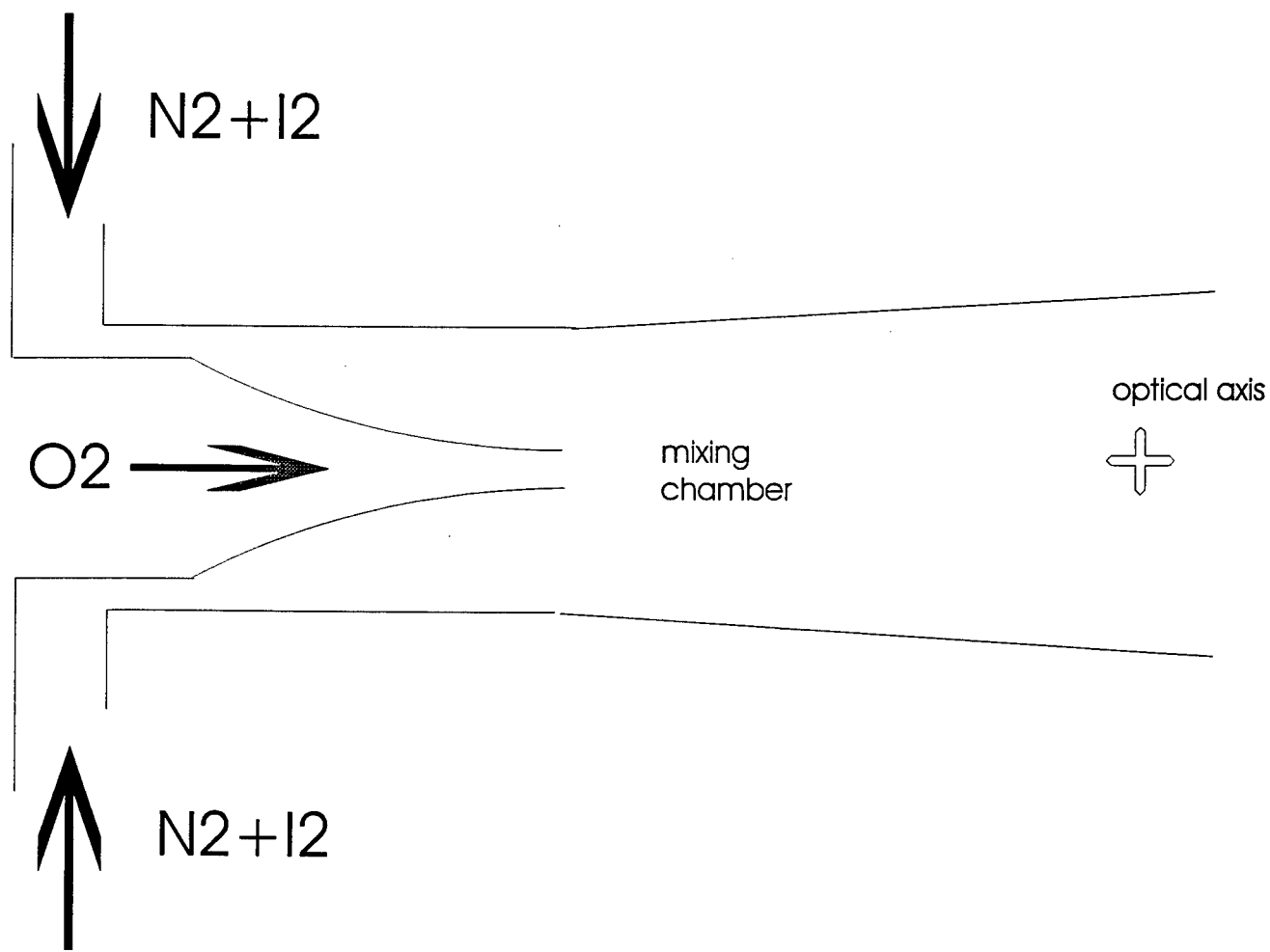

FIG.9

rate strongly. This distance increased with increasing of the nitrogen flow rate. The emission occupied the total cross section of mixing chamber. We didn't observe the green-yellow emission along the oxygen jet border. It means that very fast mixing of oxygen plain jet with N₂-I₂ flow at large shear forces on the jet's border. For total mixing of the oxygen flow with N₂-I₂ flow the partial oxygen pressure equals to $10\text{mmole/sec} : 270\text{mmole/sec} \times 3.2\text{torr} = 0.12\text{ torr}$, where 10 mmole/s is the oxygen molar flow rate and 270 mmole/s is the nitrogen molar flow rate. The rate of iodine dissociation is very small at these conditions. It was necessary to increase iodine flow rate (titration) for increasing of rate of iodine dissociation. The larger titration (I₂/O₂) resulted in larger energy losses. Unfortunately we didn't take into account the influence of the viscous effects in the oxygen nozzle on the pressure losses of this nozzle system. The SOG pressure was very large (35÷37torr) for 10 mmole/sec of the oxygen flow rate and the singlet oxygen yield was only 50% instead of 70% at 20torr¹. The oxygen jet was strongly under expanded at the nozzle exit and became supersonic with Mach number depending on the surround static pressure or nitrogen flow rate. The decrease of the nitrogen flow rate is accompanied by increasing of Mach number of the oxygen stream, compressing nitrogen jets and as results decreasing of nitrogen Mach number and shear forces on the border. We tried to obtain laser operation with mirrors 0.8% and 0.15%. The output power 19 wt have been obtained for 0.14 mole/sec of the nitrogen flow rate and 0.8 mmole/sec of the iodine flow rate. The height of laser beam spot was 15 mm. For 0.28mole/sec of the nitrogen flow rate the laser power was 12wt for 0.53 mmole/sec of the iodine flow rate and 6wt for 0.75 mmole/sec of the iodine flow rate. Then optical axis was placed on the distance 14,5 cm from the nozzle exit. The output power was 53wt for 8.1 mmole/sec of the oxygen flow rate and 62wt for 9.5 mmole/sec of the oxygen flow rate. Iodine flow rate was 0.65 mmole/sec in these cases but nitrogen flow was 0.14 mole/sec. At 0.27 mole/sec nitrogen flow rate the green-yellow emission appeared downstream optical axis only and the duct before cavity was dark.

We created second nozzle system for increasing static pressure at the inlet of the mixing chamber, decreasing N₂ flow rate and ratio N₂/O₂ flow rates (O₂ dilution degree). The nitrogen throat was decreased to 0.4 mm but exit height to 2mm. The total nozzle system exit height was 6mm and duct height was 17mm on the distance 14.5cm from nozzle. We received 600torr of nitrogen in iodine generator and 7.1 torr static pressure near nozzle exit and 4.4 torr near optical axis for nitrogen flow rate equal to 0.22mole/sec. The calculated oxygen Mach number (using the pressure drop) was 1.48 at 5.1mmole/sec oxygen flow rate and 1.7 at 8.5 mmole/sec. The Mach number of the mixed stream was 2.55 at the distance 145mm, recovered pressure - 40torr. The dark zone was more 14.5 cm for iodine flow rate 0.7mmole/sec. The green-yellow emission appeared at twice decreasing nitrogen flow rate (to 0.13mole/sec) but without lasing. The oxygen Mach number became equal to 1.9 and Mach number for mixed stream was 2.5 in this case. At decreasing nitrogen flow rate to 80mmole/sec we can see the laser generation with power 18 wt for optimal iodine flow rate 0.56 mmole/sec, cavity static pressure equal to 3.3 torr, recovered pressure -17 torr and Mach number of the mixed stream -2.27. The beam spot has height 15mm. The further decrease nitrogen flow rate to 30mmole/sec gave 15 wt at 0.31mmole/sec iodine flow rate, oxygen Mach number equal to 2.5 and Mach number of the mixed stream -1.75.

Then we have performed tests with new grid nozzle having four rows (4×17=68) 20° conical nitrogen nozzles with throat diameter equal to 1mm and exit diameter - 3mm and five rows (5×18=90) oxygen cylindrical channels with inner diameter equal to 1.2mm and 15mm length (Fig.10). It was expected than 42 oxygen nozzles located on the board of the grid injects 46% oxygen into boundary layers. and energy of this stream may be lost for laser power but we made this nozzles for decreasing JSOG pressure. The pressure inside reaction zone of JSOG was 30 torr for 10 mmole/s of initial chlorine flow rate. The O₂(¹Δ) yield in this case equaled to 60%¹. The optical axis was placed at the distance 250mm from the grid. For 40mmole/sec nitrogen flow rate the next pressures have been obtained: in the iodine generator -150 torr, in the laser cavity -1.7 torr and recovery pressure- 9 torr. The laser power was 86 wt through mirror with reflectivity 0.7%

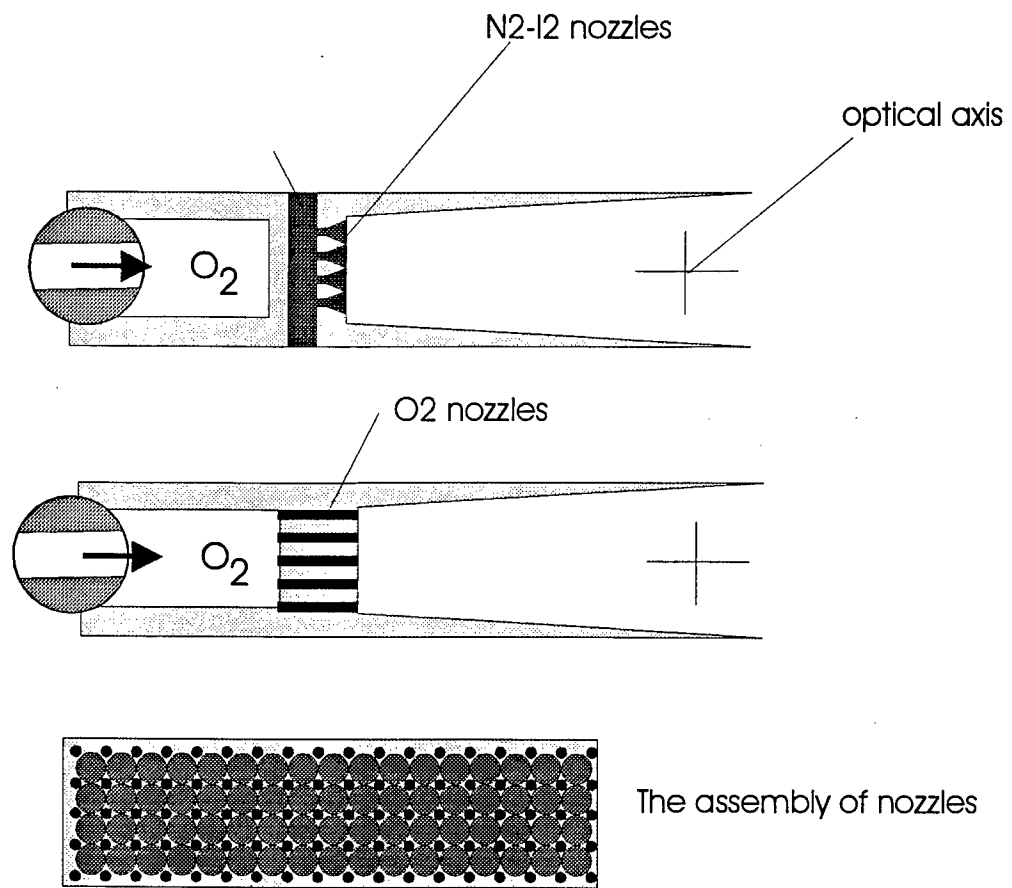

FIG.10

(second mirror has $R=0.2\%$ and total power is 110 wt) for the iodine flow rate 0.25mmole/sec and 10.7 mmole/sec of the chlorine flow rate. The bright green-yellow emission started 12÷17cm apart from array of nozzles. In the next test the output power was 70 wt for the iodine flow rate 0.3mmole/sec and chlorine flow rate 9mmole/sec. The bright green-yellow emission started 9÷16cm apart from array of nozzles in this case. The maximal recovered pressure 13.7 torr and cavity static pressure 2.16 torr ($M=2.15$) have been obtained for the nitrogen flow rate 55 mmole/sec. It is possible that last tests gave not bad results if take into account 46% oxygen has been injected into the boundary layers. But these results are received at low static pressure and low Mach number of the mixed stream.

We understood from these experiments that single slit nozzle system don't simulate real COIL conditions due to unexpected for us quick jets mixing and the quick oxygen partial pressure drop at this mixing. Small initial duct height (6 mm) and large distances from grid don't give possibility to keep gasdynamic parameters in the process of the mixing because duct height increases more than 2 times. It is necessary to use nitrogen flow rate equal to approximately 5 oxygen flow rates. Exit cross section area of nitrogen flow and total exit area oxygen flow should be equal to each other approximately. We have designed such nozzle block for new JSOG with O_2 flow rate equal to 70÷100 mmole/sec. It has 9 slit channels for oxygen and 8 conical nozzles rows (4 nozzles in row with throat diameter 1.5 mm and exit diameter 3 mm) for nitrogen with iodine. But we may say with confidence that this scheme will operate successfully at using CH_3I and the electrical discharge for iodine dissociation.

These experiments proved the realization of turbulent mixing regime for small scale gas jets with large difference of velocities such as in ejector COIL scheme. It gives possibility to design the real nozzle block for COIL with sonic-supersonic jets mixing.

1. M.V.Zagidullin, V.D.Nikolaev, M.I.Svistun, N.A.Khvatov, N.I.Ufimtzev, «Highly efficient supersonic chemical oxygen-iodine laser with a chlorine flow rate of 10 mmole/s», *Quantum Electronics*, vol.27, pp. 195-199, 1997

4. The Verti - JSOG and COIL with Verti-JSOG.

The jet type singlet oxygen generator produces the $O_2(^1\Delta)$ at high pressures with high $O_2(^1\Delta)$ yield. In the traditional version of JSOG the gas outlet was located in the wall of JSOG body. This set-up of JSOG has low capability for scaling. The JSOG with the vertical gas outlet has not limitation for scaling. The cross section of the reaction zone of JSOG should be equal to the cross section of the laser cavity. The main goal of the study of Verti-JSOG is to achieve the maximum oxygen molar flow rate per unit area in the reaction zone of JSOG (and per unit area of nozzle's exit) for the minimizing of the potential large scale JSOG. The $O_2(^1\Delta)$ yield should be high (>60%) and the chlorine utilization should be more than 90% at this maximum oxygen flux. The maximum oxygen flux is limited by these two main requirements, critical fraction of the droplets at the exit of JSOG and hydrodynamic stability of JSOG operation. The hydrodynamic stability of JSOG means that the catastrophic ejection of BHP foam into the vacuum duct does not take place. Some amount of the droplets will be at the exit of any kind of the SOG in all cases. But up to any critical value of the droplets fraction they will not seriously effect on the COIL operation. The $O_2(^1\Delta)$ yield and Cl_2 utilization can be predicted on the basis of any kind of the kinetic model. The droplet content and the limit of hydrodynamic stability can't be predicted at present.

4.1 The detail description of presented Verti-jet SOG (VJSOG).

The set-up of VJSOG is presented in fig.11, 12. The body of VJSOG has been manufactured from Plexiglas. The width 6 mm of the gas outlet was chosen as minimal but to avoid the sonic gas flow in the outlet slit. The width of reaction zone equal to 50 mm was chosen because the active length of existing COIL was 50 mm. The dimension of the reaction zone in the another direction is 34 mm. The projected maximal volume velocity in reaction zone is 42L/s. In this case the gas velocity in the gas outlet section will be less than the sonic velocity. The total cross section of the reaction zone is 17 cm². If one installs the central insert 8 mm in thickness then the reaction zone is divided into two parts 13 mm in width. In this case the total cross section of reaction zone is 13 cm². The specific surface of the jets is expected in 1.3 times higher with central insert than without it. The central insert is intended to minimize the part of the space inside the reaction zone without jets of BHP.

For injection of BHP into the reaction zone two perforated nickel plate 0.1 mm in thickness were used. In each plate the 0.7mm holes were drilled. The distance between holes was 2.1 mm. The total number of holes in each plate was equal to 138. The perforated plastic plate was installed in front of the nickel plate. The thickness of this plate was 2 mm. 138 holes 1 mm in diameter were drilled in this plate. This plastic plate was intended to attenuate tangential component of BHP velocity inside nozzles.

The chlorine was injected into the reaction zone through two perforated stainless still tubes 8 mm i.d mounted into the walls of the JSOG body. 13 holes 2 mm in diameter were drilled in each tube. It was possible to direct holes to the reaction zone or to the walls of JSOG. In the last case the expected initial tangential momentum of chlorine flow in the reaction zone will be minimal.

The O₂(¹Δ) outflow from the reaction zone through slit channel 6x50 mm² cross section and 18 mm in height.

The modified Cl₂ supply system consists of 20 L elastic envelope installed into the hard PVC vessel. The chlorine pressure inside this flexible envelope was constant during tests and equal to 1 atm. The chlorine flow rate was metered by the orifice calibrated by nitrogen at 1 atm. The molar chlorine flow rate was assumed to be equal to $M(\text{Cl}_2) = M(\text{N}_2) \cdot 12.557 / 20.363$, where $M(\text{N}_2)$ is the nitrogen molar flow rate for the calibrated orifice.

The BHP was prepared from 5 liters of 50% H₂O₂ and 5 liters of 46% KOH. It was possible to increase the pressure of BHP up to 2.5 atm relative to the pressure in the reaction zone of the VJSOG.

4.2 Test of Verti-JSOG

Description. The set-up of VJSOG is presented in fig.13. The slit (choke) 0.1 mm thickness was installed immediately downstream of the VJSOG outlet. This slit was intended to fix gas volume velocity inside of the reaction zone. The cylindrical valve was installed downstream from the choke for the fast valve off. Then the special cell with Ge and Si photo diodes was installed. This photocell was the same as used for the measurements of O₂(¹Δ) yield and H₂O content in previous contracts. The distance from the VJSOG outlet to the point of O₂(¹Δ), O₂(¹Σ) detection was 45 mm. The system was exhausted by 125 L/s vacuum

Fig 11. The sketch of verty Jet-SOG (central sectional view)

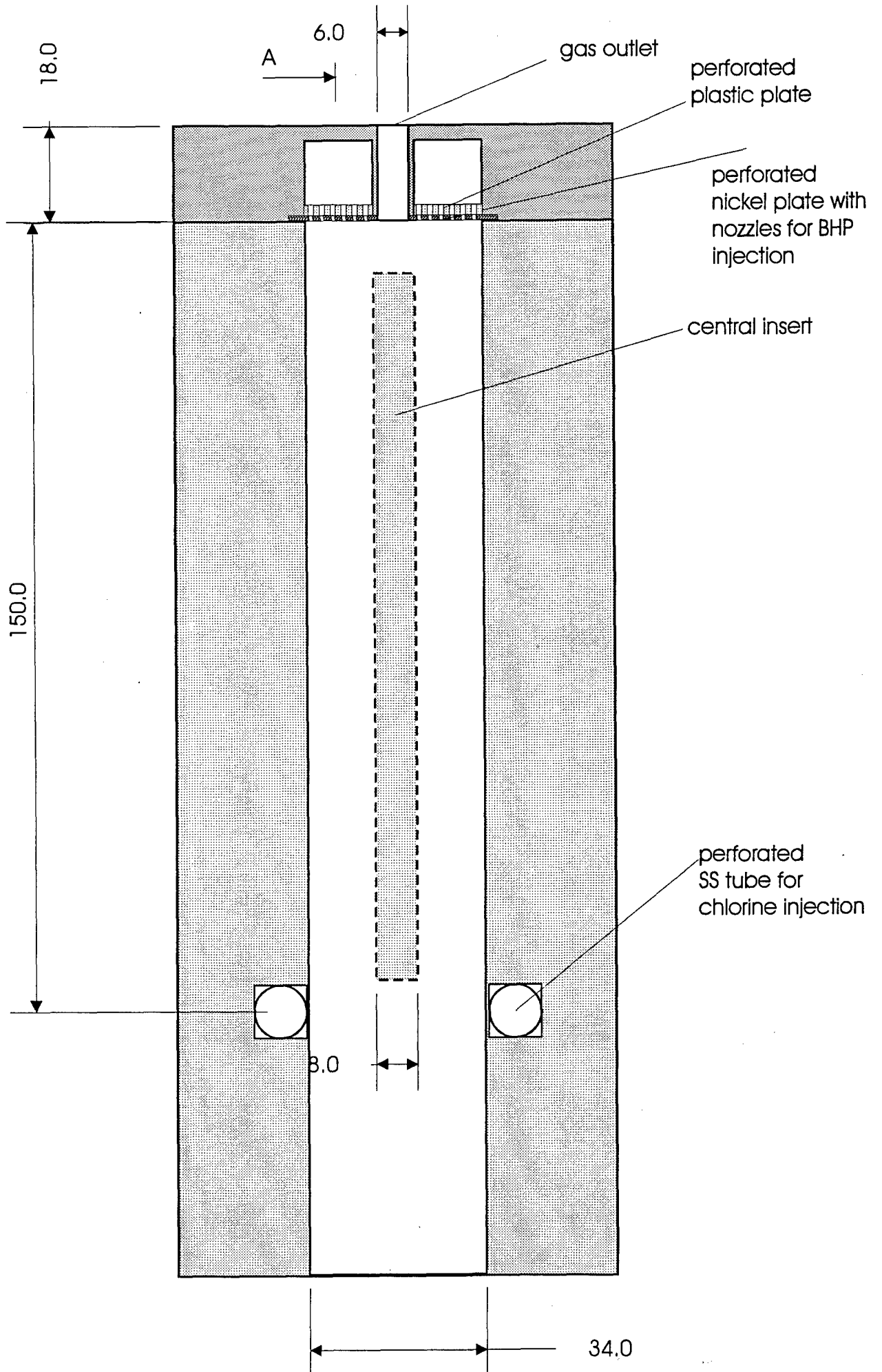
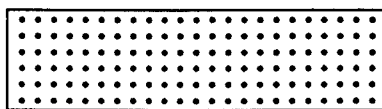
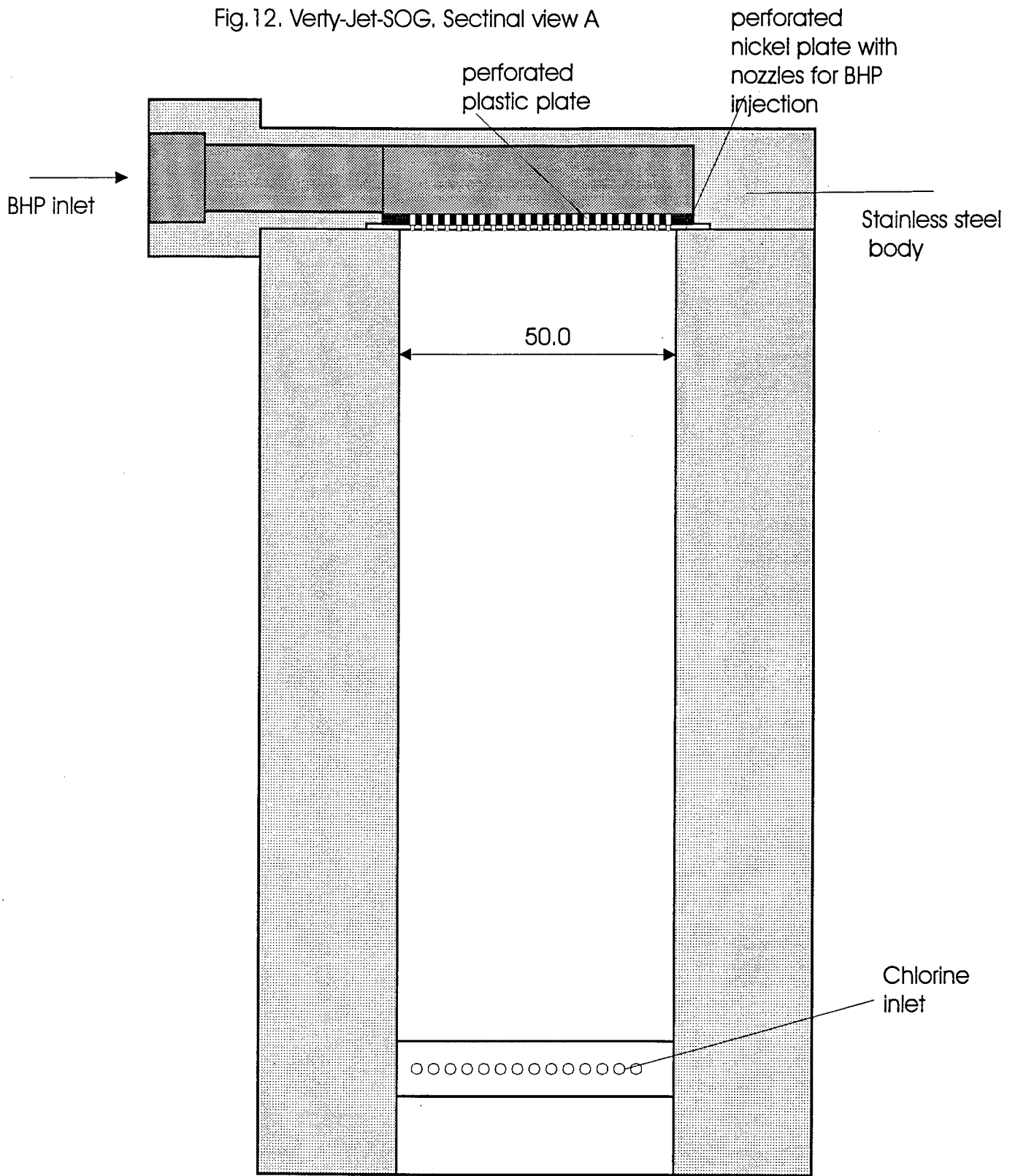

Fig. 12. Verty-Jet-SOG. Sectinal view A



Geometry of the perforated plate for BHP injection

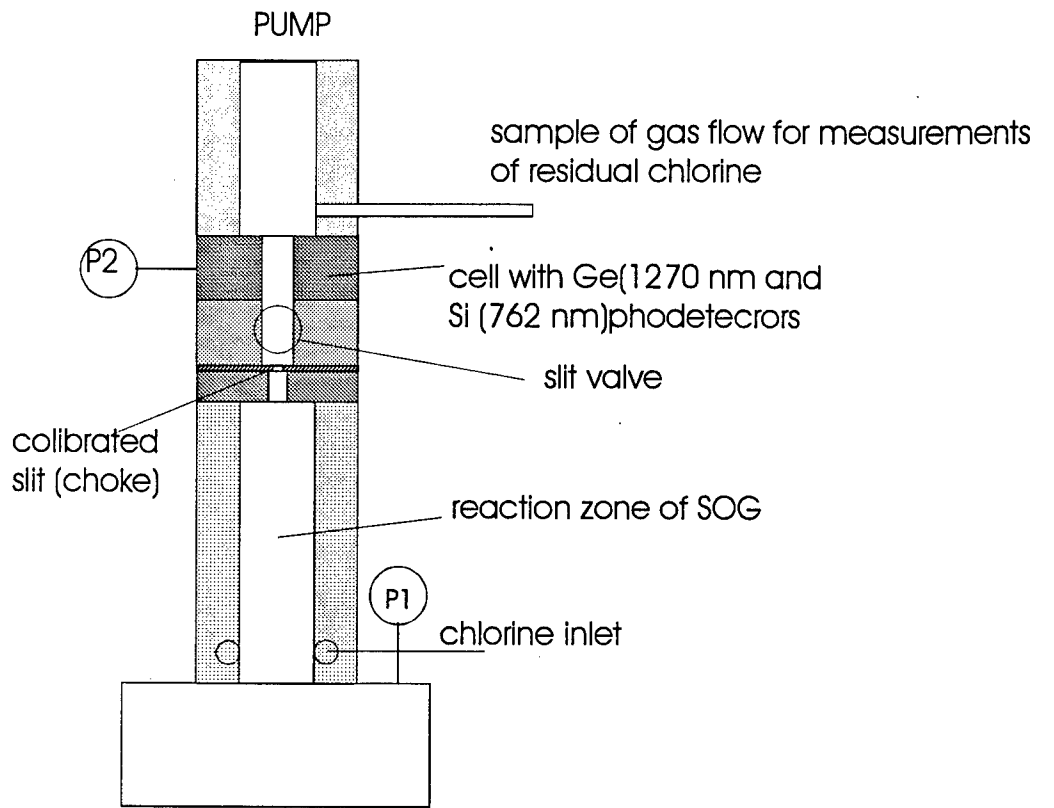

Fig. 13

pump. The cross section of the duct between VSOG outlet and the end of photocell was 10x50 mm². The gas velocity in the point of O₂(¹Δ) detection was approximately ≈150 m/s. A very short residence time and low pressure in the duct allowed to detect the O₂(¹Δ) yield at the exit of VJSOG. The cross section of the duct downstream of the photocell was 30x50 mm². The small amount of the gas flow was directed into the tube 50 cm in length where the residual chlorine was measured by the absorption spectroscopy method at 337 nm wavelength. The position of the pressure gauge in the set-up is presented in Fig.13. There were measured the pressure P1 in lower part of the reaction zone, the static pressure P2 of the gas flow in the photocell.

The preliminary test of hydrodynamic stability of VSOG with nitrogen. For the preliminary estimation of the upper limit of the hydrodynamic stability of VJSOG the nitrogen was used instead of the chlorine. The BHP was cooled to -15C and initial pressure of BHP was 1 atm. The BHP flow rate was 600 ml/s or the average BHP velocity inside 0.7 mm nozzle was 5.66 m/s. The average gas velocity in the lower part of the reaction zone was calculated as $U_g = M_N / \rho / S$. Because the temperature of the gas at the exit of VJSOG is unknown the density ρ (mole/cm³) is «assumed» to be equal to the density for the gas at temperature 298K: ρ (mole/cm³) = $(P1 - PH2O) * 1333.3 / R / 298$, $R = 8.31 \times 10^7$ erg/mole/K, PH2O is the water vapor partial pressure. The «calculated» gas velocity in this case is U_g (m/s) = $18.57 M_N / S / (P1 - PH2O)$, where P1 is the pressure in torr, M_N (mmole/s) gas molar flow rate, S (cm²) is the cross section of reaction zone and 18.57 is a coefficient. The pressure P1 consists of the pressure of the gas and water vapor. The water vapor in lower part of reaction zone was assumed to be equal to the saturated at -15C or $PH2O \approx 1$ torr. The test results of the hydrodynamic stability of VJSOG operation with nitrogen is presented in Table2.

Table 2. In column N.6 the pressure P1 obtained for dry (without jets) runs with nitrogen.

Run	Central insert	Nitrogen molar flow rate M_N , mmole/s	average gas velocity U_g in the lower part of the reaction zone	P1, torr	P1(dry), torr	Stability
1	NO	96	21.8 m/s	49	46	good
2	NO	116	19.2 m/s	67	58.6	low stability
3	Yes	96	«20 m/s»	absolutely unstable		
4	Yes	68	14.5 m/s	68	46	low stability
5	Yes	43	15.75	40	30	good

In run 3 gas velocity ≈20 m/s was predicted from the previous VJSOG run because the same choke at the exit of VJSOG was used.

«Good» stability means that in the reaction zone the good BHP jets were observed and there was'n foam of BHP inside reaction zone. «Low stability» means that

some amount of foam starting near nitrogen inlet have been observed. The height of the foam was approximately 50 mm. This foam chokes the gas flow. At any time the pressure in the receiving tank can be increased and «pump effect» can occur and catastrophic ejection of BHP foam into the vacuum duct takes place.

«Absolutely unstable» means that the BHP ejection into vacuum duct occurred immediately after the gas injection into the VJSOG.

After these «cold» experiments we decided to operate without the central insert because the VJSOG is more stable without central insert.

3. The «hot» test of VJSOG.

The hydrodynamic stability of VJSOG operating with chlorine have been tested before the measurements of $O_2(\Delta)$ yield and Cl_2 utilization. The results these tests are presented in Table 3. The typical picture of the red emission from the reaction zone of VJSOG is presented in Fig.16.jpg

Table 3.

	Central insert	Chlorine molar flow rate, mmole/s	average gas velocity U_g in the lower part of the reaction zone, m/s	Jet velocity U_j , m/s	P1, torr	Stability
1	NO	42.5	15.5	5.66	31	good
2	NO	42.5	15.5	5.66	31	good
3	NO	56	15	5.66	42	low stability
4	NO	56	15.3	5.66	41	low stability
5	NO	73	13.3	5.66	61	low stability
6	No	73	13.3	5.66	61	low stability
7	NO	89	≈13(assumed)	5.66	absolutely unstable	
8	NO	42.5	17.5	5.66	26.5	good
9	NO	56	15.7	5.66	39	low stability
10	NO	73	≈16(assumed)	5.66	absolutely unstable	
11	NO	73	≈16(assumed)	5.66	absolutely unstable	
12	NO	56	13.9	5.66	45	good
13	NO	56	16.5	5.66	38	low stability
14	NO	73	≈16(assumed)	5.66	absolutely unstable	
15	NO	56	17.5	8	36	good
16	NO	73	16.3	8	50	good
17	NO	88	16	8	61	low stability
18	NO	88	16.6	8	59	low stability
19	NO	73	17	5.66	48	low stability
20	NO	73	17	8	48	good

8 m/s of jet velocity was obtained for 2.5 atm initial pressure of BHP.

The operation of VJSOG with the chlorine quietly differ from the operation with nitrogen at the same molar flow rate. The hydrodynamic stability much worse with the chlorine than with the nitrogen. When VJSOG operated with chlorine the pressure P1 is higher than the pressure P1 in the case of operation with the

Fig. 1.4 The assembly of JSOG with COIL (with array of nozzles)

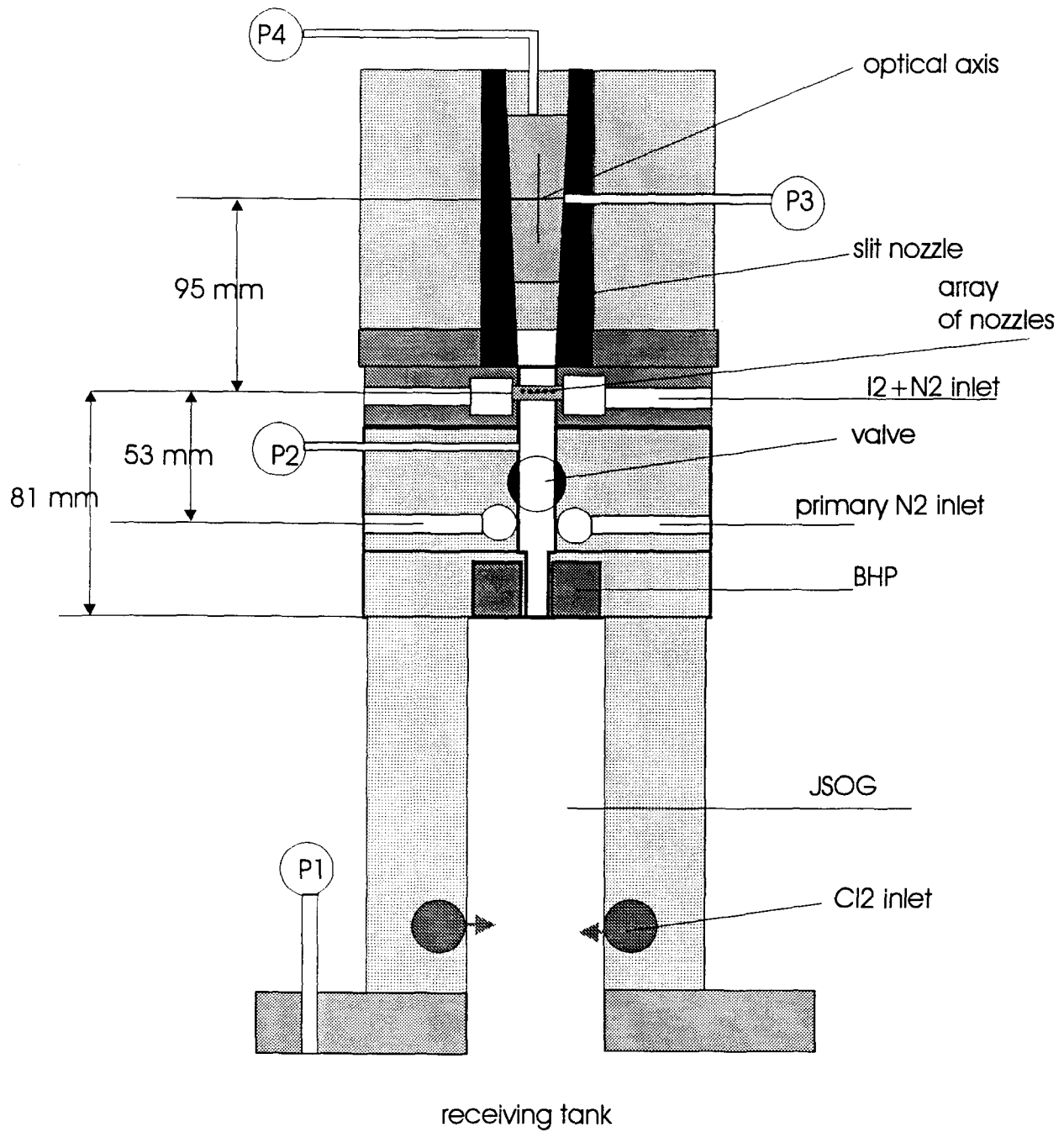

nitrogen at the similar conditions. For example, compare the run N.1 (Table 2) with run 6 or 17 in Table 3. The higher pressure P1 in the case of chlorine is due to the higher pressure losses in the reaction zone. It can be due to higher molecular weight of the chlorine and higher losses of the gas flow momentum ρU_g^2 .

In last three runs the holes of the chlorine injector were directed to the walls of VJSOG. In all other runs the holes of the chlorine injector were directed to the reaction zone. In runs where catastrophic ejection of BHP into the vacuum duct took place the estimations of the gas velocity were not made but the initial gas velocity was estimated from the successful tests performed with the same outlet slit (choke). In runs 12,13 measurements of the chlorine utilization was not performed because in the previous run N.11 the BHP penetrated into the absorption spectroscopy tube.

The successful runs where the $O_2(^1\Delta)$ yield and Cl_2 utilization have been measured are marked in the previous Table 3. In Table 4. The results of the measurements of $O_2(^1\Delta)$ yield, Cl_2 utilization and the water vapor fraction in successful runs are presented.

Table 4.

Run	M_c	U_g	U_j	P_1	P_2	Y	Ut	η_{H_2O}
1	42.5	15.5	5.7	31	8.7	68	93	0.046
2	42.5	15.5	5.7	31.3	10.7	60	95	0.034
3	56	15	5.7	41.8	11	58	95.5	0.057
4	56	15.3	5.7	41.1	12	50	97.5	0.03
5	73	13.3	5.7	61	15.1	47	99	0.02
6	73	13.3	5.7	61	15.3	55	100	0.038
8	42.5	17.5	5.7	26.6	9.74	84	91.5	0.058
9	56	15.7	5.7	39	11.6	73	92	0.07
15	56	17.5	8	36	13.2	85	91.5	0.055
16	73	16.3	8	50	16.4	71	90.4	0.045
17*	88	16	8	61	18	53	94	0.035
18	88	16.6	8	59	17.8	73	86	0.05
19	73	17	5.7	48	15.1	68	87.5	0.04
20	73	17	8	48	15.6	65	84	0.045

*In run 17 it was found that window for Ge-detector was polluted by some amount of BHP.

Here: M_c is the chlorine molar flow rate (mmole/s), U_g (m/s) is the average gas velocity in the lower part of the reaction zone, U_j (m/s) is the average BHP velocity in the jet nozzle, P_1 (torr) is the gas pressure in the lower part of the reaction zone, P_2 (torr) is the gas pressure in the point of $O_2(^1\Delta)$ detection, Y(%) is the $O_2(^1\Delta)$ yield, Ut(%) is the chlorine utilization, η_{H_2O} (%)= $P(H_2O)/P_2$ is the water vapor content in the point of $O_2(^1\Delta)$ detection

In all tests the BHP aerosol was observed in the vacuum duct. The water vapor fraction decreases with increasing of the pressure P_1 . But in several runs the water vapor content was higher than it was expected. It is due to entrainment of droplets by the gas flow into the vacuum duct.

The lowest partial water vapor pressure inside VJSOG $P_2 \cdot \eta_{H_2O} = 0.8$ torr (run 5) is close to the saturated water vapor pressure at -17C. The highest water vapor partial pressure $P_2 \cdot \eta_{H_2O} = 2$ torr (run 18) is more than saturated at -15C. It is due to higher level of droplets fraction in run 18.

2. The COIL with array of small nozzles driven by Verti-JSOG.

The array of iodine mixer-nozzles was identical to that tested in p.2 of the present report. The opposite direction of the nozzles was chosen because the COIL in this position of the nozzles demonstrated higher chemical efficiency with the chlorine flow rate 10 mmole/s. The assembly of VJSOG with the laser cavity is presented in Fig.14. The $O_2(^1\Delta)$ from JSOG flows through the duct $1 \times 5 \text{ cm}^2$ to the array of the small nozzles. The length of the duct from the exit of the reaction zone of JSOG to the array of nozzles is 81 mm (Fig.14). The primary nitrogen (if it was needed) is mixed to the $O_2(^1\Delta)$ flow 53 mm upstream from the array of nozzles. The choke at the exit of VJSOG was removed in this case. The height of the slit nozzle at the position of the optical axis was 21 mm. The total cross section area 2.5 cm^2 of the throat is too small to mix a large amount of the primary and secondary gas and to avoid «off-design» conditions in VJSOG (more higher pressure in VJSOG than was designed). For this reason we tried to operate without primary nitrogen buffer gas.

The photo of COIL operation with the Verti-JSOG is presented in the Fig17.jpg attached file.

All test of COIL runs is presented in Table 5.

Table 5.

Run	I_a mmole/s	$\Phi_1(\text{SOG})$ torr	Φ_2 (plenum) torr	Φ_3 (cavity) torr	P4 (Pito) torr	$M_N(P)$ mmole /s	$M_N(S)$ mmol e/s	MI2 mmole /s	T1, T2, %	W total w	$\eta\%$	Mach
1	42.5	33	30	2.8	9.17	10	10	0.34	0.8;0.2	200	5.2	1.5
2	42.5	34	31	2.4	10.2	10	10	0.42	0.8;0.2	200	5.2	1.7
3	42.5	33	30	2.4	11.9	10	10	0.2	0.8;0.2	100	2.6	1.85
4	42.5	33	31	2.6	9.1	10	10	0.47	0.8;0.2	178	4.65	1.5
5	42.5	35	33	2.6	9.3	10	10	0.36	0.8;0.2	202	5.2	1.55
6	42.5	33	31	2.6	6.2	13	6.6	0.38	0.8;0.2	155	4.05	1.2
7	42.5	36	35	2.6	7.8	6.6	14	0.4	0.8;0.2	225	5.9	1.4
8	42.5	37	36	2.6	7.8	0	22	0.6	0.8;0.2	221	5.8	1.4
9	42.5	37	36	2.6	7.8	0	22	0.46	0.8;0.2	245	6.4	1.4
10	42.5	35	33	2.4	10.9	0	20	0.29	0.8;0.1 8	160	4.15	1.75
11	42.5	35	33	2.5	10.5	0	20	0.42	0.8;0.1 8	295	7.7	1.65
12	42.5	35	33	2.6	10.3	0	20	0.57	0.8;0.1 8	243	6.33	1.65
13	42.5	33	32	1.9	10.3	0	20	0.29	0.8;0.1 8	200	5.18	1.95
14	42.5	33	32	2.2	9.5	0	20	0.45	0.8;0.1 8	355	9.2	1.75
15	42.5	33	33	2.2	9.6	0	20	0.55	0.8;0.1 8	294	7.6	1.72
16	73	66	58	3.1	17	0	20	0.43	0.8;0.1 8	200	3	1.95
5	73	59	51	3.9	17	0	20	0.43	0.8;0.1 8	143	2.16	1.72
6	56	52	48	2.8	15.5	15	20	0.43	0.8;0.1 8	295	4.46	2
7	56	48	44	2.9	12.8	0	20	0.43	0.8;0.1 8	270	5.32	1.75
8	56	48	44	2.4	14	0	20	0.28	0.8;0.1 8	114	1.72	2.05
9	56	50	46	3	12	0	20	0.56	0.8;0.1 8	262	4	1.65

Fig.15 The assembly of JSOG with COIL (with slit nozzle)

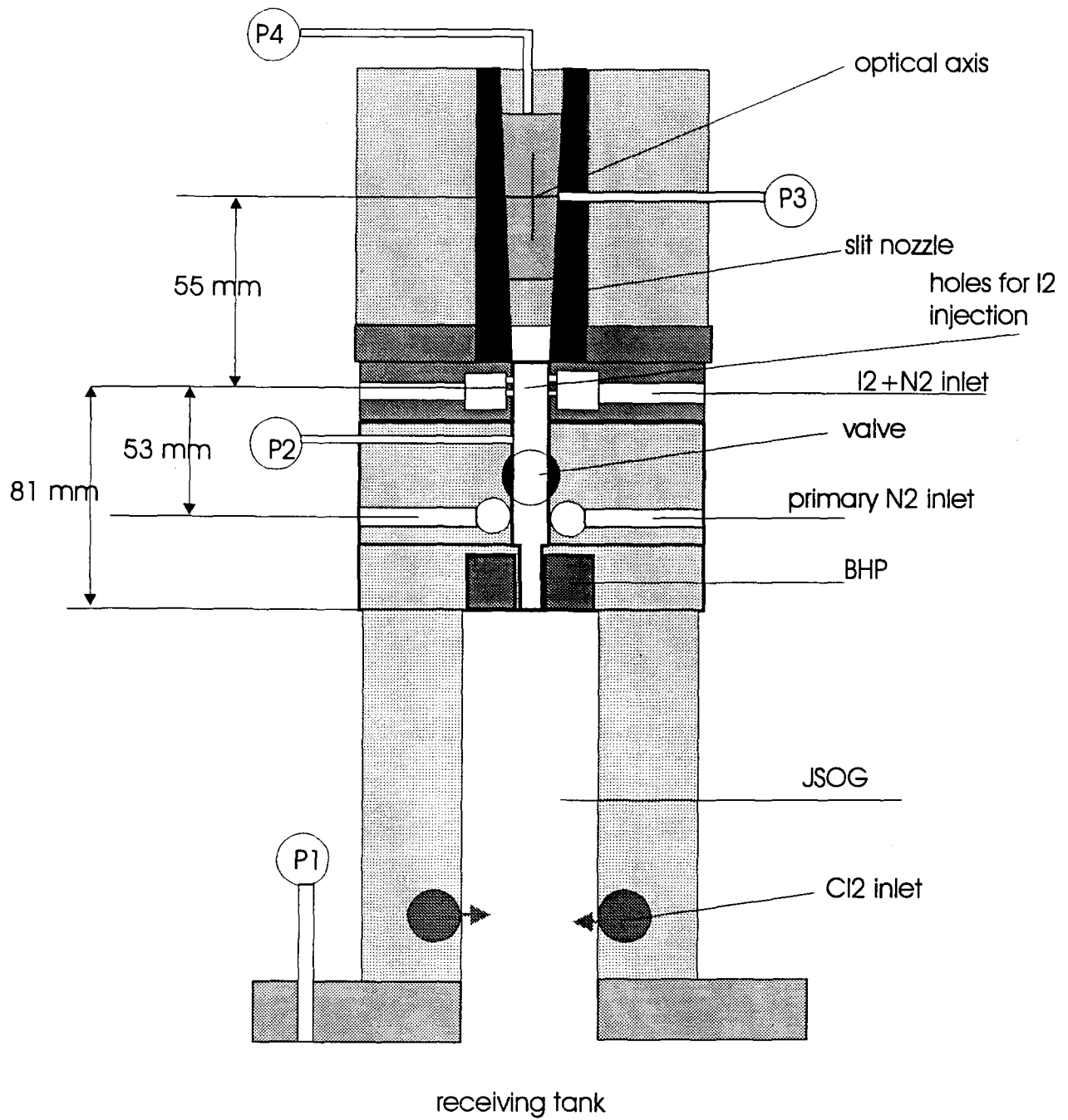



Fig 16

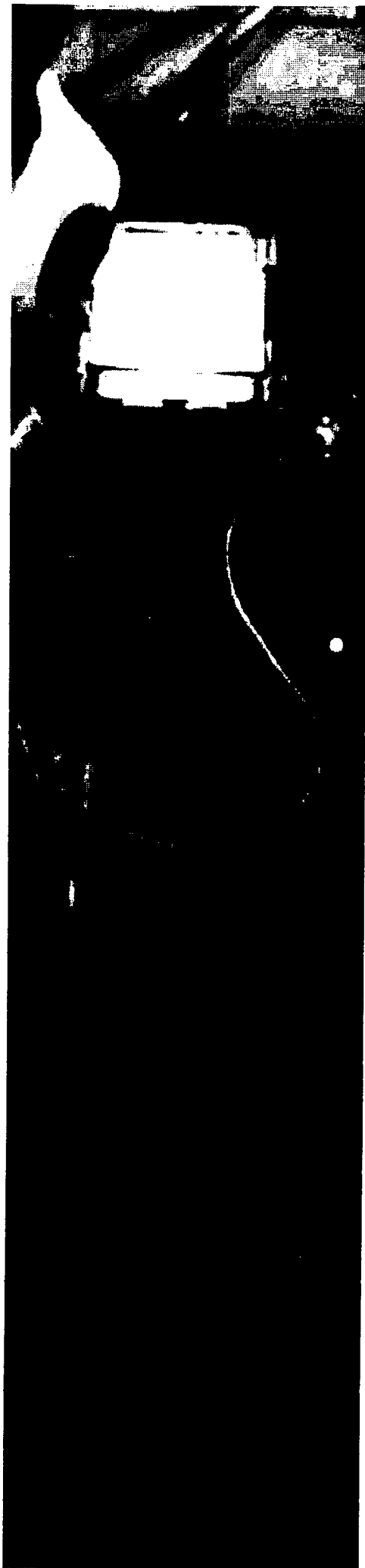

Fig 17

Here M_c is the chlorine flow rate, P1 is the pressure in the receiving tank, P2 is the plenum pressure, P3 is the pressure in the laser cavity, P4 is the pressure in Pito tube, MI2 is the iodine flow rate, W is the total output power from both mirrors, $\eta\%$ is the chemical efficiency, Mach is estimated Mach number of the gas flow velocity in the laser cavity.

The pressure in the reaction zone of VJSOG during COIL operation was higher than in the case of VJSOG operation with slit nozzle. It is due to «off-design» operation of VJSOG because of primary and secondary nitrogen choked VJSOG outlet.

The chemical efficiency of COIL with the array of small nozzles for 42.5 and 73 mmole/s of the chlorine flow rate much less than the efficiency obtained for 10 mmole/s of the chlorine flow rate (report 3). It is due to higher $O_2(^1\Delta)$ transport losses at high $O_2(^1\Delta)$ pressure and higher BHP aerosol fraction at the exit of Verti-JSOG. The power is not reproducible at the same identical conditions. We explain it by uncontrolled amount of the droplets at the exit of VJSOG.

3. COIL operation with slit nozzle and VJSOG.

Several experiments have been performed with slit nozzle and tangential injection of the iodine into the oxygen flow. The COIL+VJSOG set-up is presented in Fig.15. The cross section of the throat of the slit nozzle was 5 cm²(height is 1 cm, width is 5 cm). The cross section of the throat is twice more than the cross section of the choke used in VJSOG tests in the design conditions. It allowed to operate at «design» operation conditions of VJSOG and with dilution of oxygen by primary nitrogen. The iodine was injected tangentially into the oxygen through the system of orifices (Fig.15). The first row of orifices consists of 21 holes 0.5 mm in diameter and located 2 mm apart from the throat. The second row consists of 21 holes 0.7 mm in diameter and located 2 mm apart from the first row. The profile of the slit nozzle was calculated by method of characteristics for the adiabatic gas flow. In Table 6 the results of COIL operation with slit nozzle are presented.

Table 6

Run	I_n mmole/s	Δ_1SO G torr	Δ_2 (plenum) torr	Δ_3 (cavity) torr	P4 (Pito) torr	$M_N(P)$ mmole /s	$M_N(S)$ mmole /s	MI2 mmole /s	T1, T2, %	W total w	$\eta\%$	Mach
1	56	37	28	3.6	19	40	40	0.44	0.8;0.18	689	13.6	1.9
2	56	37	28	4	19	40	40	0.58	0.8;0.1 8	690	13.6	1.8
3	56	35	22	4.4	19	56	20	0.44	0.8;0.1 8	471	9.3	1.7
4	56	40	30	3.7	19	20	60	0.44	0.8;0.1 8	627	12.3	1.9
5	56	38	27	4.5	20	40	40	0.53	1.7;0.1 8	695	13.7	1.75

In spite of droplets in the laser cavity the output power of the COIL with the slit nozzle much more than with the array of small nozzles. We explain it by lower transport losses of $O_2(^1\Delta)$ and lower losses of $O_2(^1\Delta)$ in mixing-dissociation region.

7. SUMMARY and CONCLUSIONS

1. The upgrade of the COIL facility have been made. Now COIL is able to operate at 100 mmole/s of Cl_2 and up to 2 mmole/s of I_2 with He dilution during 10sec.

2. At 10 mmole/s of Cl_2 through the «old» JSOG the chemical efficiency 20% have been achieved in COIL with array of small nozzles. For the reverse position of the array of nozzles (rake type) the chemical efficiency is higher than in the case of direct position of the array of nozzles. It is due to shorter residence life-time of O_2+I_2 mixture at high pressure.

3. The advanced Verti-JSOG have been designed and manufactured. The VJSOG operated successfully at chlorine flow rate up to 90 mmole/s. But some amount of droplets have been observed at the exit of VJSOG. The $\text{O}_2(^1\Delta)$ yield 60÷70% and Cl_2 utilization $\geq 90\%$ have been achieved for Cl_2 molar flow rates up to 90 mmole/s.

4. Tests of COIL with advanced VJSOG and rake type mixing system were performed. For Cl_2 molar flow rate 42.5 mmole/s and plenum pressure 30÷35 torr the maximum chemical efficiency 9.2% have been achieved. At 56 mmole/s Cl_2 molar flow rate and plenum pressure 50 torr the maximum chemical efficiency 5.32% have been achieved.

5. Test of COIL with advanced VJSOG and slit nozzle have been performed. The maximum chemical efficiency 13.7% have been achieved for 56 mmole/s of Cl_2 molar flow rate and 27 torr plenum pressure. In the case of slit nozzle the total cross section area of the throat is higher than in the case of array of nozzles. It resulted in decreasing of the plenum partial oxygen pressure and residence time.

6. Problem 1. The oxygen flow from VJSOG contains some amount of droplets which increase the water vapor fraction in the mixing-dissociation zone. It is necessary to decrease or to eliminate the droplet fraction at the exit of VJSOG. It is necessary to increase jet stability for solving this problem.

What do we plan to do? First of all we plan to use the cylindrical nozzles in the plastic plate 4 mm in thickness instead of orifices in the thin nickel plate for the generation of BHP jets. We plan slightly change the gas outlet configuration to avoid BHP entrainment by the gas flow from the walls.

7. Problem 2. The oxygen partial plenum pressure and gas residence time for COIL with array of small nozzles was too high for Cl_2 flow rate more than 40 mmole/s. It resulted in $\text{O}_2(^1\Delta)$ losses. In the case of slit nozzle these losses were lower. It is necessary to decrease $\text{O}_2(^1\Delta)$ transport losses.

What do we plan to do? For array of nozzles we plan to increase the height of the throat up to 2 cm instead of existing 1 cm. For slit nozzle system we plan to use two parallel slit nozzles with throat height 7 mm (total height 14 mm). Another way is to use the array of ejector mixing system (transonic O_2 +supersonic N_2+I_2) where nitrogen gas will not choke the oxygen flow. This array consists of 9 small scale ejectors. All this methods will be applied in the case of N_2 buffer gas.

The O_2 plenum partial pressure and residence time can be decreased for «old» mixing-nozzle systems in the case of using He buffer gas.
