

AFRL-PR-WP-TR-1998-2119

Investigation of TESCOM Driveshaft Assembly
Failure

James A. Kenyon

Technology Evaluation Branch
Turbine Engine Division

October 1998

Final Report for 4/1/98 - 10/31/98

Approved for public release; distribution is unlimited.



19990316 075

Propulsion Directorate
Air Force Research Laboratory
Air Force Materiel Command
Wright-Patterson AFB, OH 45433-7251

BTIC QUALITY INSPECTED 1

NOTICE

USING GOVERNMENT DRAWINGS, SPECIFICATIONS, OR OTHER DATA INCLUDED IN THIS DOCUMENT FOR ANY PURPOSE OTHER THAN GOVERNMENT PROCUREMENT DOES NOT IN ANY WAY OBLIGATE THE US GOVERNMENT. THE FACT THAT THE GOVERNMENT FORMULATED OR SUPPLIED THE DRAWINGS, SPECIFICATIONS, OR OTHER DATA DOES NOT LICENSE THE HOLDER OR ANY OTHER PERSON OR CORPORATION; OR CONVEY ANY RIGHTS OR PERMISSION TO MANUFACTURE, USE, OR SELL ANY PATENTED INVENTION THAT MAY RELATE TO THEM.

THIS REPORT IS RELEASABLE TO THE NATIONAL TECHNICAL INFORMATION SERVICE (NTIS). AT NTIS, IT WILL BE AVAILABLE TO THE GENERAL PUBLIC, INCLUDING FOREIGN NATIONS.

THIS TECHNICAL REPORT HAS BEEN REVIEWED AND IS APPROVED FOR PUBLICATION.

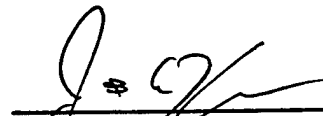

JAMES A. KEFYON
Aerospace Engineer
Technology Evaluation Branch

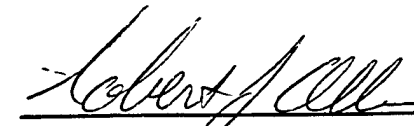

ROBERT J. ALLEN
Acting Chief
Technology Evaluation Branch
Turbine Engine Division
Propulsion Directorate



WILLIAM E. KOOP
Chief of Technology
Turbine Engine Division
Propulsion Directorate

Do not return copies of this report unless contractual obligations or notice on a specific document requires its return.

REPORT DOCUMENTATION PAGE			Form Approved OMB No. 0704-0188	
Public reporting burden for this collection of information is estimated to average 1 hour per response, including the time for reviewing instructions, searching existing data sources, gathering and maintaining the data needed, and completing and reviewing the collection of information. Send comments regarding this burden estimate or any other aspect of this collection of information, including suggestions for reducing this burden, to Washington Headquarters Services, Directorate for Information Operations and Reports, 1215 Jefferson Davis Highway, Suite 1204, Arlington, VA 22202-4302, and to the Office of Management and Budget, Paperwork Reduction Project (0704-0188), Washington, DC 20503.				
1. AGENCY USE ONLY (Leave blank)		2. REPORT DATE OCTOBER 1998	3. REPORT TYPE AND DATES COVERED 4/1/98 - 10/31/98	
4. TITLE AND SUBTITLE INVESTIGATION OF TESCOM DRIVESHAFT ASSEMBLY FAILURE			5. FUNDING NUMBERS PE 62203 PR 3066 TA 17 WU 10	
6. AUTHOR(S) JAMES A. KENYON				
7. PERFORMING ORGANIZATION NAME(S) AND ADDRESS(ES) PROPULSION DIRECTORATE AIR FORCE RESEARCH LABORATORY AIR FORCE MATERIEL COMMAND WRIGHT PATTERSON AFB OH 45433-7251			8. PERFORMING ORGANIZATION REPORT NUMBER	
9. SPONSORING/MONITORING AGENCY NAME(S) AND ADDRESS(ES) PROPULSION DIRECTORATE AIR FORCE RESEARCH LABORATORY AIR FORCE MATERIEL COMMAND WRIGHT PATTERSON AFB OH 45433-7251 POC: JAMES A. KENYON AFRL/PRTE (937)255-6802 EXT 243			10. SPONSORING/MONITORING AGENCY REPORT NUMBER AFRL-PR-WP-TR-1998-2119	
11. SUPPLEMENTARY NOTES				
12a. DISTRIBUTION AVAILABILITY STATEMENT APPROVED FOR PUBLIC RELEASE; DISTRIBUTION IS UNLIMITED.			12b. DISTRIBUTION CODE	
13. ABSTRACT (Maximum 200 words) THIS REPORT SUMMARIZES THE INVESTIGATION INTO THE FAILURE OF THE DRIVESHAFT ASSEMBLY DURING TESCOM COMPRESSOR TESTING. THE DRIVESHAFT ASSEMBLY AND COMPRESSOR WERE DISASSEMBLED AND INSPECTED, AND DATA RECORDED DURING TESTING WAS PLAYED BACK AND ANALYZED. THIS REPORT PROVIDES DETAILS OF THE INSPECTION AND ANALYSIS. RESULTS INDICATE THAT THE DRIVESHAFT ASSEMBLY FAILED AS A RESULT OF AN UNPREDICTED SHAFT NATURAL FREQUENCY IN THE OPERATING RANGE OF THE COMPRESSOR. RECOMMENDATIONS ARE PROVIDED TO REDUCE THE POSSIBILITY OF SUCH FAILURES DURING FUTURE TEST PROGRAMS.				
14. SUBJECT TERMS DRIVESHAFT ASSEMBLY, FAILURE, TEST FACILITY			15. NUMBER OF PAGES 46	
			16. PRICE CODE	
17. SECURITY CLASSIFICATION OF REPORT UNCLASSIFIED	18. SECURITY CLASSIFICATION OF THIS PAGE UNCLASSIFIED	19. SECURITY CLASSIFICATION OF ABSTRACT UNCLASSIFIED	20. LIMITATION OF ABSTRACT UL	

Table of Contents

	Page
List of Figures	iv
List of Tables.....	v
Preface.....	vi
1.0 Introduction	1
1.1 TESCO background.....	1
1.2 Description of facility.....	2
1.2.1 Test chamber.	3
1.2.2 Drive system.....	3
1.2.3 Computer systems.	4
1.3 Description of TESCO test compressor.....	5
2.0 Chronology of Driveshaft Assembly Failure.....	13
3.0 Investigation of Failure.	17
3.1 Disassembly and inspection of TESCO compressor and drive system.	17
3.1.1 Inspection of driveshaft assembly.	17
3.1.2 Inspection and repair of facility drive system.....	18
3.1.3 Inspection of TESCO compressor.	19
3.2 Data analysis.....	20
4.0 Findings and conclusions.	36
5.0 Recommendations.	38
6.0 References	40

List of Figures

Figure	Page
1.1 Compressor Research Facility.....	8
1.2 CRF test chamber.....	9
1.3 CRF drive system.....	10
1.4 TESCOM compressor in test chamber.....	11
1.5 TESCOM driveshaft assembly.....	12
2.1 Jackshaft vibrations during the first MIN SPEED run.....	15
2.2 Jackshaft vibrations during the second MIN SPEED run.....	16
3.1 Photograph of hole in inner exit flow path.....	23
3.2 Photograph of driveshaft assembly pieces recovered from inner exit flow path.....	24
3.3 Driveshaft assembly failure points.....	25
3.4 9-inch spacer at jackshaft interface.....	26
3.5 High speed jackshaft at driveshaft assembly interface.....	27
3.6 Aft end of failed flex pack.....	28
3.7 Forward end of failed flex pack.....	29
3.8 Aft portion of failed spline shaft adapter which remained with driveshaft assembly.....	30
3.9 Spline portion of the spline shaft adapter and bolts in compressor main shaft.....	31
3.10 Spline portion of the spline shaft adapter.....	32
3.11 Fracture surface of the spine shaft adapter under 10X microscope.....	33
3.12 High speed jackshaft proximeter probe time histories showing amplitude increase with each pass.....	34
3.13 Time histories of pertinent transducers.....	35

List of Tables

Table	Page
1.1 Emergency actions.....	5
1.2 TESCOm geometric parameters.....	6
1.3 TESCOm design aerodynamic performance.....	6

Preface

This report was prepared by Mr. James A. Kenyon of the Air Force Research Laboratory, Propulsion Directorate, Turbine Engine Division, Technology Evaluation Branch, Wright-Patterson Air Force Base, Ohio. The work was accomplished between 1 April 1998 and 31 October 1998, and was conducted at the Compressor Research Facility (CRF) under Project 3066, Task 17, Work Unit 30661710.

The author wishes to thank the staff of the Compressor Research Facility for their assistance in performing this investigation. In particular, the author would like to thank Dave Peabody and Gary Howell for providing results from the disassembly and inspection of the hardware after the failure. Thanks also go to Patrick Russler (Battelle Memorial Institute) and Richard Taylor for reducing and analyzing the data recorded during the test effort, and to Herb Law and 1Lt Willy Ziminsky for providing background information necessary to complete this report. Finally, thanks go to Ron Wolgast for his assistance in microscopic photography.

1.0 Introduction

The 2-stage configuration of the TESCOM compressor was tested on 13 April, 1998. During this test, two attempts were made to reach minimum speed ("MIN SPEED") and to perform a facility and compressor mechanical checkout. During the first attempt, a facility instrumentation malfunction occurred after reaching a stable MIN SPEED condition, leading to a facility shutdown. During the second acceleration to MIN SPEED, a second facility shutdown occurred, this time prior to reaching MIN SPEED. Preliminary inspection of the compressor and drive system indicated that the driveshaft coupling assembly between the gearbox and the compressor had failed. This report describes the ensuing investigation into the failure and its findings, including possible causes and recommendations to prevent future events of this nature.

1.1 TESCOM background.

The TESCOM compressor described in this report is a 2.5-stage, low aspect ratio, axial-flow compressor. The performance objectives of this compressor were derived from a preliminary design study of a three-stage core compressor for an advanced turbofan engine. The design and test programs were separated into three phases in which each stage was to be built and tested separately. The two-stage compressor was to meet phase two objectives of the program.¹

The first stage of the compressor was originally designed in 1979 and tested in 1983.^{2,3} This original configuration is referred to as rotor 1A. It was redesigned in 1979, with the new design tested in 1982, prior to testing of the original design.^{4,5} The redesigned first stage is referred to as rotor 1B. Performance of rotor 1B was judged to be slightly better than that of rotor 1A, and was therefore used in the design of the second stage. All design philosophy and data can be found in References 1 - 5.

The second stage was fabricated and initially tested in 1985. Speeds above 80 percent design speed could not be investigated due to high compressor vibrations and

inadequate clearance between the second stage stator vanes, which were cantilevered at the case, and the adjacent rotating hub. Aerodynamic performance was not measured during these tests. The compressor was disassembled and modified to alleviate these problems. It was then reassembled and tested in 1990 through 1992. At the outset of these tests, the compressor failed to achieve design performance. A remote controlled vane actuation system was installed in the compressor in early 1991 to improve performance, but the compressor again failed to reach predicted levels of overall pressure ratio or efficiency. It was also clear that the compressor was choked at speeds over 90 percent of design speed. All attempts to relieve choking and to improve performance to the predicted levels by varying vane angles and schedules were unsuccessful.

It was concluded that the disappointing performance of the 2.5-stage compressor was caused by a breakdown of the flow over rotor 2. Whether this breakdown was caused by choking in rotor 2, a mismatch between stage 1 outlet and stage 2 inlet conditions, or a mismatch between rotor 2 and stator 2 was unclear. A variety of circumstances may have contributed to the inability of rotor 2 to perform as expected. Testing to investigate the problems associated with rotor 2 performance and to evaluate several means of improving performance was being performed at the time of the driveshaft assembly failure.

1.2 Description of test facility.

Previous testing of the TESCOM compressor was accomplished at the Compressor Aero Research Laboratory (CARL) at Wright-Patterson Air Force Base, Ohio. However, the incident described in this report took place while testing at the Compressor Research Facility (CRF), also located at Wright-Patterson Air Force Base. The CRF supports the experimental efforts of the Turbine Engine Research Center (TERC) of the Air Force Research Laboratory Propulsion Directorate. It provides the means for testing the steady-state and transient behavior of full-scale, multistage, single spool compressors and small fans.

The layout of the facility is shown in Figure 1.1. The CRF is comprised of four buildings. Building 71B contains the control room and personnel offices. The test chamber, drive motors, and signal conditioning room are located in Building 20A, while the high voltage frequency converters that power the drive system are in Building 20. Cooling water pumps and an associated water tower are housed in Building 71D. In addition to these buildings, Building 21 contains the buildup area for test compressor preparation.

1.2.1 Test chamber.

The CRF is an open-cycle system in which the test compressor provides the motive power for moving air through the facility. The test chamber is shown schematically in Figure 1.2. The compressor is mounted inside a 20-foot diameter test chamber vessel. It draws filtered air from the atmosphere into the test chamber plenum through an array of five inlet control valves which can be used to regulate inlet pressure for simulation of operation at altitude. A flow conditioning barrel is mounted inside the test chamber plenum with screens and flow straighteners to minimize extraneous inlet flow distortions. From the plenum, air enters the compressor bellmouth before entering the compressor. A close-coupled discharge valve at the compressor exit is used to control the compressor pressure ratio and thus blade loading. Discharge air passes into a collector and then into ducting which directs the flow into an acoustically treated atmospheric discharge stack. The facility can provide airflow rates from 15 to 500 lb_m/sec to the test compressor.

1.2.2 Drive system.

The CRF powers test compressors through a synchronous electric drive system, resulting in accurate fixed rotational speeds. Alternating current at a frequency of 60 Hz is converted into variable frequency through the use of a rotating transformer, or frequency converter. Variable frequency is achieved by varying the rotational speed of this rotating transformer. The frequency converter allows for control of the drive motor

speed by varying the frequency of the resulting alternating current. This signal is sent from Building 20 to Building 20A to power the electric drive motors.

Test compressors are driven by either of two 30,000 horsepower synchronous electric drive motors through two speed increasing gearboxes. A schematic of the drive system is shown in Figure 1.3. Various motor/gearbox combinations result in a range of operating speeds and power. For the TESCOM compressor, the high speed motor, high speed gearbox number three, and the high speed jackshaft were used. This yielded a MIN SPEED condition of 6544 rpm, the speed at which the control computers gain variable speed control of the test compressor. This configuration was chosen to obtain the compressor corrected design speed of 20,476 rpm. The maximum mechanical speed of the drive system with this configuration was 29,992 rpm.

In this configuration, the drive system poses speed restrictions on the TESCOM compressor in addition to those posed by the compressor itself. The first of these occurs between 4600 rpm and 5600 rpm, where an axial resonant frequency of the high speed gearbox number three shaft is excited. Operation in this range is limited to reduce wear on the slip ring components.

A second speed restriction occurs between 19,466 rpm and 19,794 rpm due to frequency converter zero rpm constraints. As previously pointed out, the frequency converter varies the frequency of the electrical power to the drive motors to allow speed control of the test article. Counter-clockwise rotation of the frequency converter causes the output power signal to be less than 60 Hz, while clockwise rotation of the frequency converter causes the output power signal to be greater than 60 Hz. The zero rpm constraint occurs when the frequency converter changes from counter-clockwise rotation to clockwise rotation. Operation in this condition is restricted to prevent localized heating of the slip rings which transfer electrical power into the rotating reference frame.

1.2.3 Computer systems.

The CRF computer systems are comprised of six computers networked to serve two primary functions, Facility/Test Article Control and Data Acquisition and Analysis. The control computer system includes two Facility Control Computers (FCC1 and FCC2)

and the Test Article Control Computers (TAC1 and TAC2). Data acquisition and analysis are performed on a VAX. A Monitor Computer interfaces with the four control computer subsystems.

The Programmable Logic Controllers (PLC's) and the Control Computer System are responsible for controlling facility mechanical and electrical systems and compressor variable geometry. In addition, the control computers monitor facility health parameters, transmit facility status and data for display and storage, and initiate appropriate emergency actions when required. The emergency actions available are shown for reference in Table 1.1. Facility support systems are controlled primarily by the PLC's.

Table 1.1. Emergency actions.

Emergency Command	Accel/Decel Rate	Target Speed
MIN SPEED	250 rpm/sec	6544 rpm
IDLE SPEED	250 rpm/sec	8185 rpm
MAX SPEED		21,500 rpm
E-STOP 1	500 rpm/sec	0 rpm
E-STOP 2	750 rpm/sec	0 rpm
E-STOP 3	1000 rpm/sec	0 rpm
E-TRIP	Coast down	0 rpm

1.3 Description of TESCOM compressor.

The TESCOM compressor is a high-speed, low aspect ratio, two-stage axial-flow compressor with a corrected tip speed of 1250 ft/sec at design. The flowpath casing diameter downstream of the inlet guide vane exit was constant at 14.0 inches, resulting in a corrected shaft speed of 20,476 rpm at design. The maximum speed of the compressor is 105 percent of design speed, or 21,500 rpm. The compressor consists of 36 inlet guide vanes, 34 first-stage rotor blades, 54 first-stage stator vanes, 74 second-stage rotor blades, and 88 second-stage stator vanes. Some geometric parameters of the compressor are shown in Table 1.2. The predicted aerodynamic specifications of the compressor are shown in Table 1.3. During previous test programs, the compressor did not achieve

predicted performance. Consequently, the current test is being conducted to determine the reasons for this.

Table 1.2. TESCOM geometric parameters.

Parameter	Value
First-Stage Inlet Radius Ratio	0.643
Second-Stage Inlet Radius Ratio	0.829
Average First-Stage Rotor Aspect Ratio	0.720
Average First-Stage Stator Aspect Ratio	0.836
Average Second-Stage Rotor Aspect Ratio	0.740
Average Second-Stage Stator Aspect Ratio	0.767

Table 1.3. TESCOM design aerodynamic performance.

Parameter	Value
Flow Rate (lb _m /sec)	25.00
Total Pressure Ratio	4.587
Isentropic Efficiency	0.855

The TESCOM compressor is shown mounted in the CRF in Figure 1.4. The test compressor was mounted to the rear of the test chamber using an F100 rear mount frame adapted to the compressor. The flow conditioning barrel was adapted to fit the compressor inlet as shown in the diagram. Air is pulled through the adapted flow conditioning barrel by the test compressor and exits through the inner exit flowpath to the CRF exhaust plenum.

The compressor drive system consists of the driveshaft assembly and the balance piston. The compressor drive system is shown in more detail in Figure 1.5. Several new drive system components were required to adapt the test compressor to the CRF drive system. These new components included adapter 1, between the spline shaft adapter and the forward flex-pack, as well as the Kop-Flex coupling spacer between the flex-packs. Upon assembly of the rig in the chamber, it was determined that the compressor driveshaft assembly was 9 inches too short to connect to the CRF main driveshaft. To

alleviate this disparity, a 9-inch spacer was fabricated and installed between adapter 2 and the CRF jackshaft. The effect of this additional spacer on drive system dynamics was not determined prior to testing.

The driveshaft assembly also serves as the wireway for lead wires to blade-mounted instrumentation on the test compressor. For TESCOM, this consisted of strain gages on rotor 2 blades. The lead wires from the strain gage were passed through the hollow center of the driveshaft assembly. A foam filler was sprayed into the hollow areas of the driveshaft assembly to hold the strain gage leads in place along the centerline of the assembly.

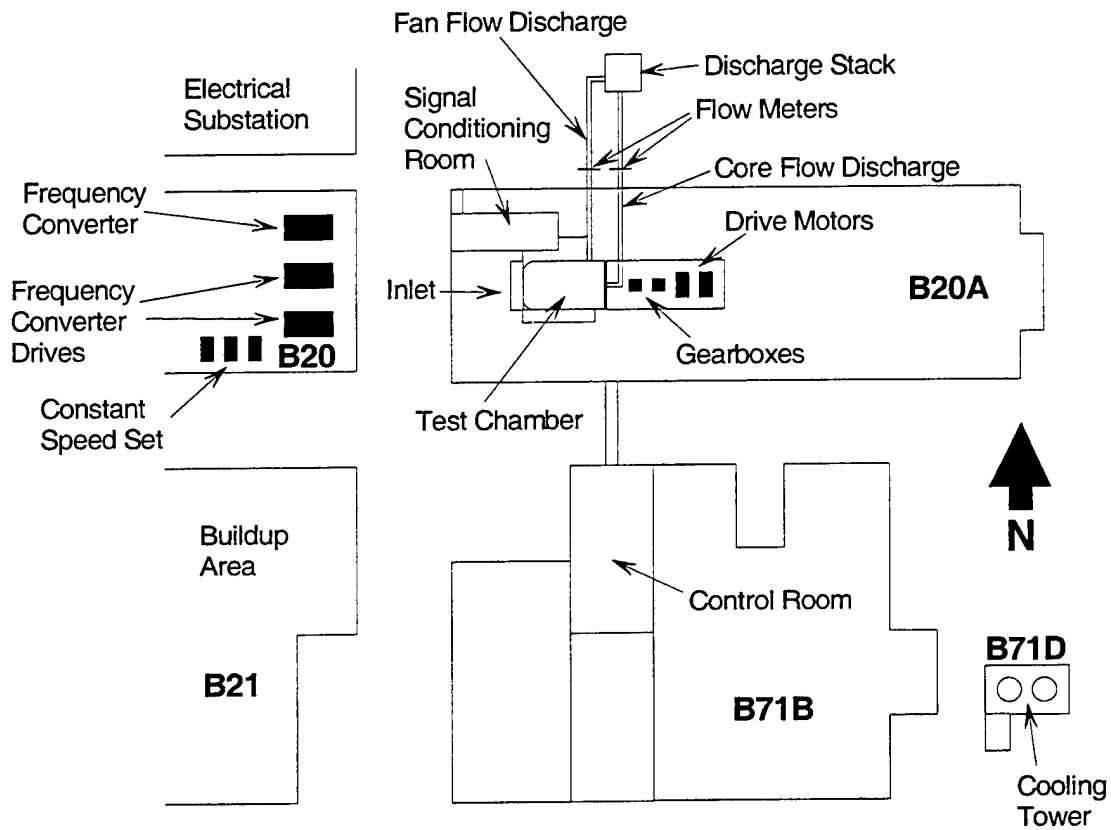

Figure 1.1. Compressor Research Facility.

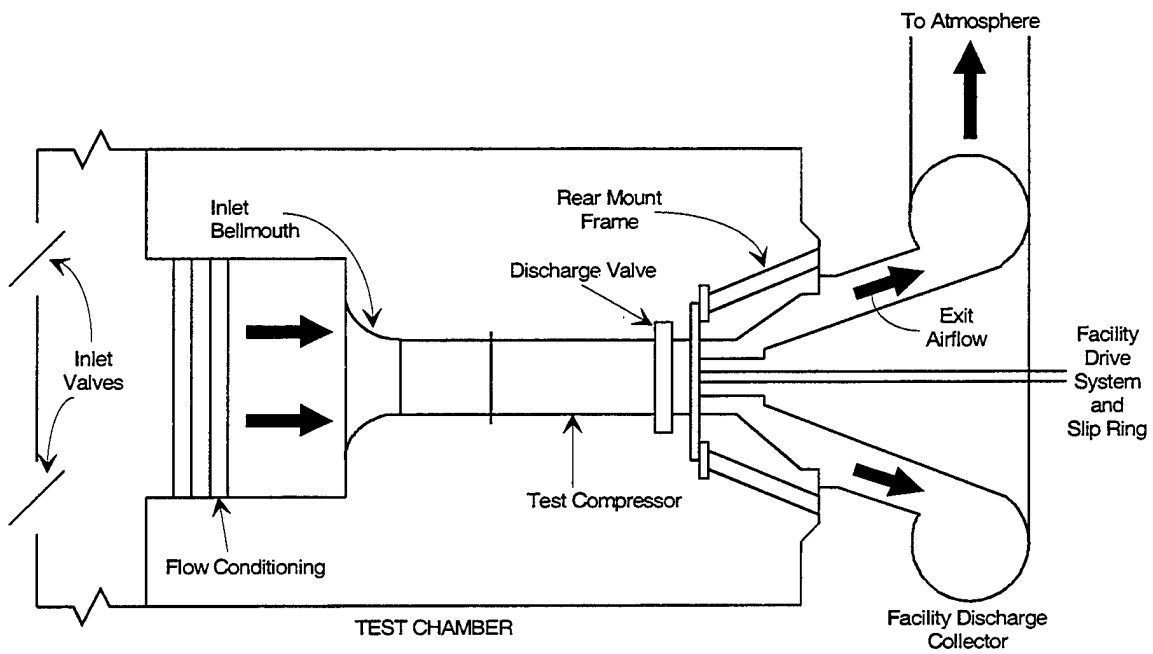

Figure 1.2. CRF test chamber.

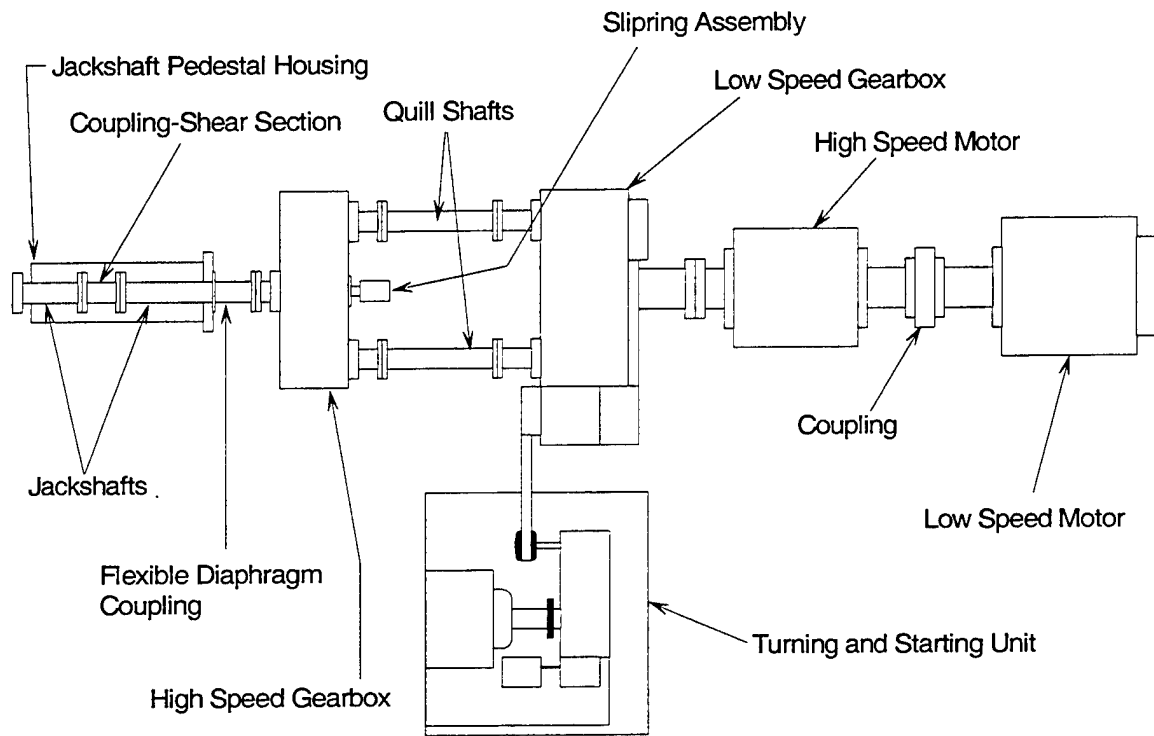

Figure 1.3. CRF drive system.

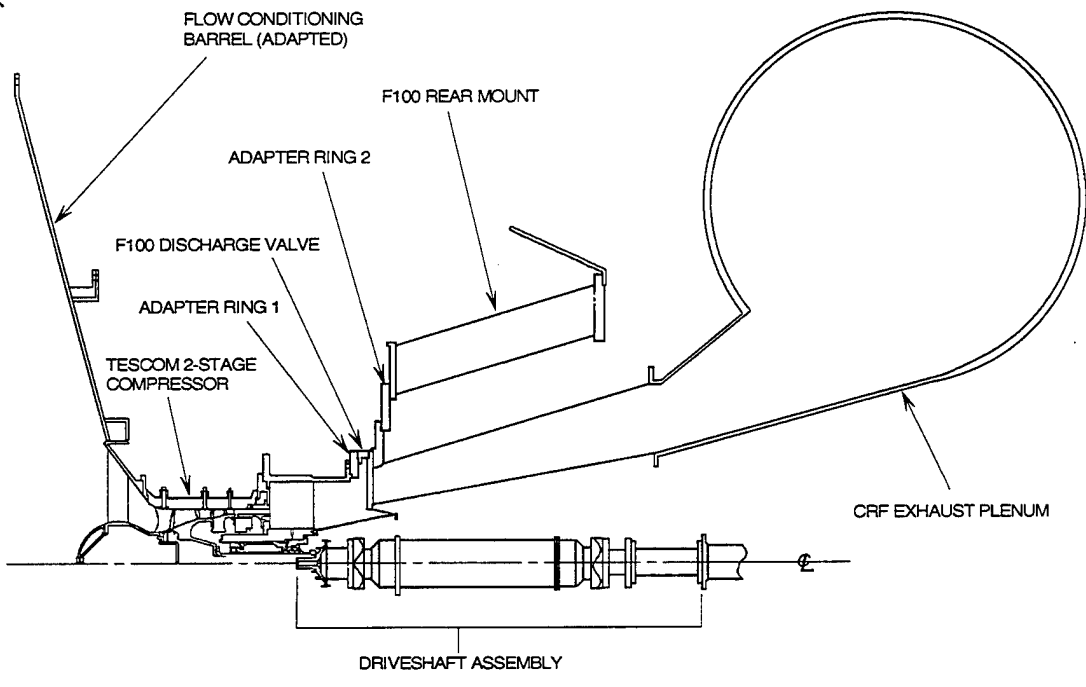

Figure 1.4. TESCOM compressor in test chamber.

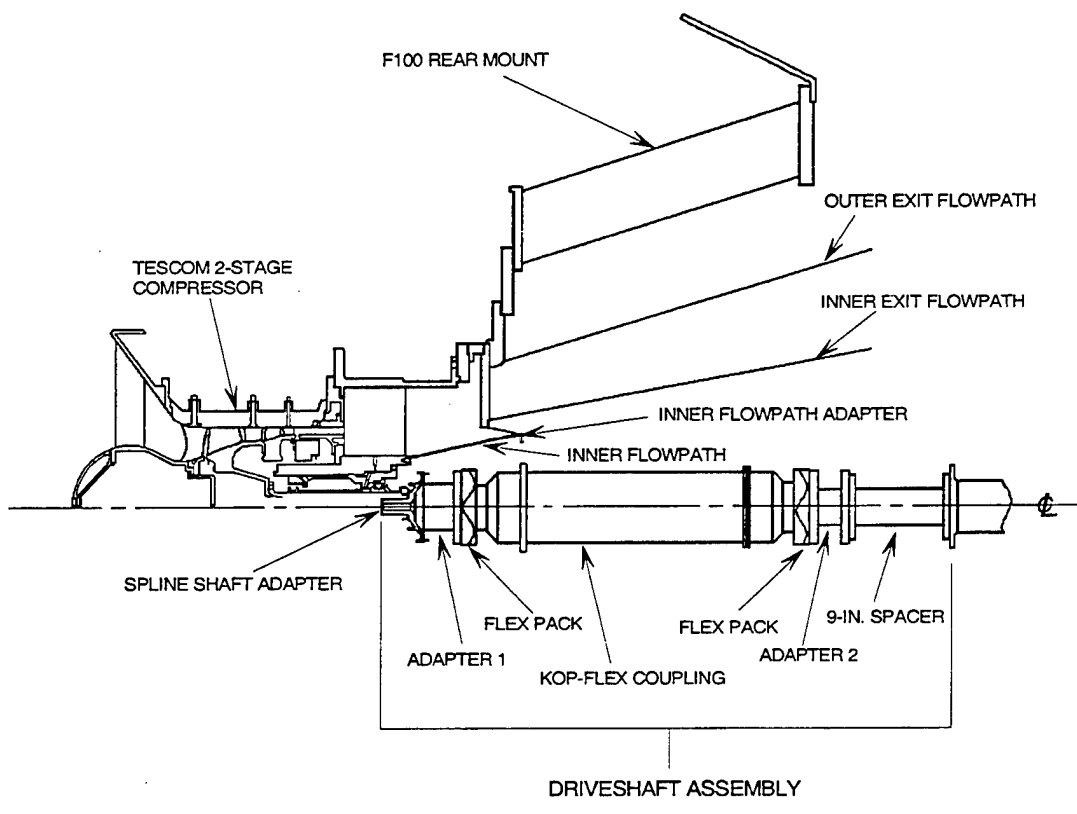

Figure 1.5. TESCOM driveshaft assembly.

2.0 Chronology of Driveshaft Assembly Failure

Testing of the two-stage TESCOM compressor was intended to investigate poor performance observed during previous test programs and to examine ways to correct this performance. Prior to evaluating the aerodynamic performance of the compressor, the compressor and drive system were required to undergo mechanical checkout.

On 13 April, 1998, two attempts were made to perform a compressor and facility mechanical checkout. During the first attempt, which started at 13:20, a stable MIN SPEED condition was successfully reached at 6544 rpm for the gearbox configuration used during this test. However, an apparent shaft critical speed was crossed during the acceleration to MIN SPEED. High vibrations were noted in jackshaft proximity probes at approximately 6150 rpm. Vibration amplitudes reached nearly 8 mils. The alarm limit is 5 mils. A MIN SPEED command was the prescribed action for this condition, Table 1.1, but it is unknown whether that command was issued by the control computers since variable speed control had not been obtained and the compressor was already accelerating to MIN SPEED. Vibrations dropped to approximately 2 mils after crossing the critical speed. The MIN SPEED condition was maintained for approximately 5 minutes before the facility control computers issued an E-STOP command. See Table 1.1. The critical speed was again observed as the rig decelerated to stop, with high vibrations in the jackshaft proximity probes at 6150 rpm. Vibration amplitudes at the critical speed during the deceleration reached more than 10 mils, greater than during the acceleration to MIN SPEED. No alarm was noted for this crossing since the E-STOP command had already taken effect. The run was concluded at 13:28. Figure 2.1 shows the proximity probe vibration amplitudes during the first MIN SPEED run. In the figure, headers ZRE-02 and ZRE-04 represent the jackshaft proximity probes.

Investigation of the E-STOP revealed three problems. No gearbox speed signal (1/rev) was available from the drive system. In addition, the chamber microphone used for health monitoring was not plugged in. Finally, an inlet valve for control of reduced inlet pressures failed. This final condition produced the E-STOP command that

terminated the first mechanical checkout run. No inspection of the driveshaft assembly was made despite the high vibration levels during the first run. All three of the noted conditions were corrected, and a second mechanical checkout was attempted.

The second attempt at mechanical checkout was started at 15:16. High vibrations again occurred near the 6150 rpm critical speed. However, the jackshaft proximity probes reached a sharp peak of more than 10 mils and suddenly dropped off to a steady amplitude of approximately 4 mils p-p. Drive system vibration levels during the second run are shown in Figure 2.2. Once again, ZRE-02 and ZRE-04 represent the proximity probes on the jackshaft. Proximity probes on the test compressor indicated vibrations in excess of 10 mils, and accelerometer amplitudes from the compressor suddenly dropped. Again, it is unknown whether the control computers issued a MIN SPEED command. Approximately 3 seconds after the change in signals, one of the programmable logic computers (PLC2) initiated an E-STOP command, and the compressor began to decelerate from 6250 rpm at a rate of approximately 70 rpm/sec. The reason for the E-STOP command from PLC2 has not been determined. Twenty-two seconds after the E-STOP command was issued, jackshaft proximity probes and compressor accelerometers suddenly blossomed again and then dropped to less than 1 mil p-p. Compressor proximity probes dropped to less than 5 mil p-p. Strain gage signals from the test compressor also ended at this time. The gearbox and compressor speed signals began to diverge, and each coasted to stop uneventfully at different rates. The MIN SPEED condition was not reached during the second run, which ended at approximately 15:18. Vibration amplitudes will be discussed in more detail in Section 3 of this report.

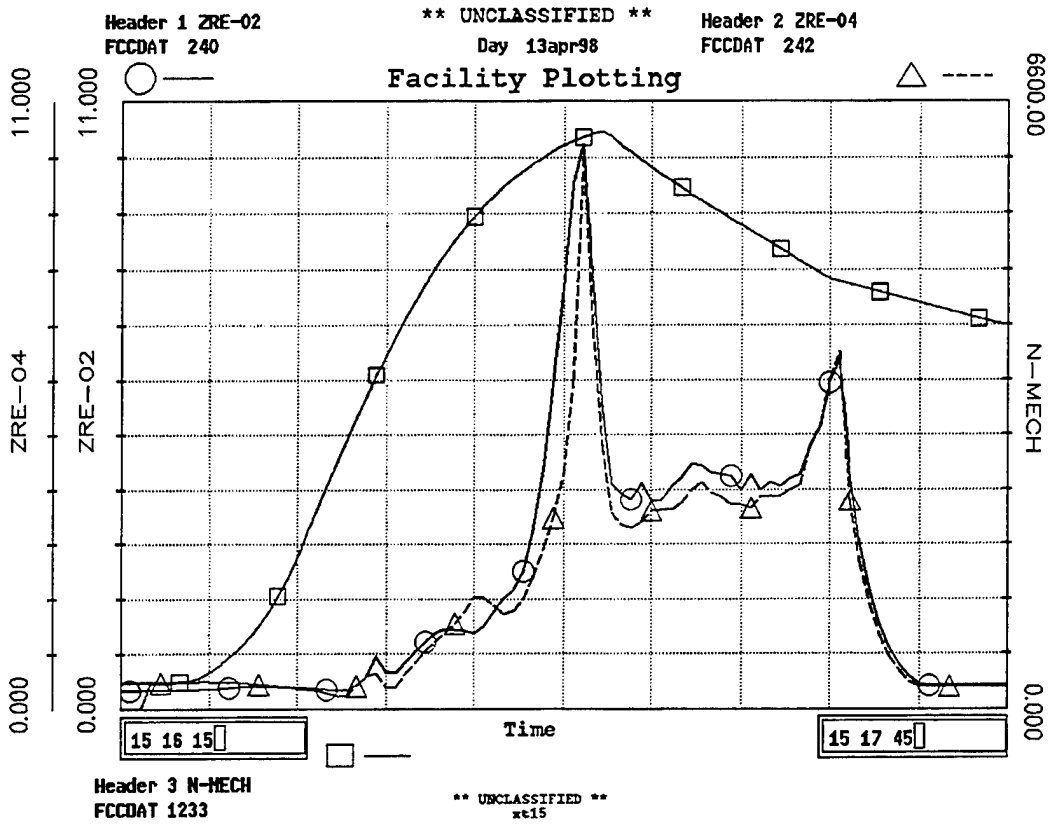

Figure 2.2. Jackshaft vibrations during the second MIN SPEED run.

3.0 Investigation of Failure

Investigation of the TESCOM driveshaft assembly failure consisted of two primary parts: disassembly and inspection of the compressor and drive system and analysis of the data acquired during the two runs. The disassembly and inspection as well as the data analysis were completed within a week of the incident. The sections that follow describe in detail the steps taken during the investigation and the principle results.

3.1 Disassembly and inspection of TESCOM compressor and drive system.

A visual inspection of the test compressor and drive system was performed. During visual inspection from the gearbox area, pieces of the driveshaft assembly could be seen lying in the duct comprising the inner exit flow path. The outer exit flow path was opened, and an oval hole measuring 6 inches by 2.5 inches was found in the inner exit flow path at about the 4 o'clock position, aft looking forward. A photograph of the hole is shown in Figure 3.1. The inner exit flow path was opened, and the driveshaft assembly was found in three pieces. Two of these pieces were lying side by side in the bottom of the inner exit flow path, and the third piece, the spline portion of the spline shaft adapter, was still in the TESCOM main shaft. The pieces of the driveshaft assembly were removed from the test chamber for detailed inspection. A photograph of the pieces recovered from the inner exit flow path is shown in Figure 3.2. The facility drive system was also inspected in detail.

3.1.1 Inspection of driveshaft assembly.

Inspection of the driveshaft assembly revealed three points of failure. These are shown in Figure 3.3. One of these was the connection point between the high speed jackshaft and the 9-inch spacer used in the driveshaft assembly. At this point, nine (9) 5/16 inch shoulder bolts were pulled axially through the nuts securing them. A photograph of the spacer at this point is shown in Figure 3.4. The corresponding part of

the jackshaft is shown in Figure 3.5. The coarse gray material at the end of the jackshaft and in the center of the spacer in the photographs is the foam filler used to secure the strain gage leads. A second point of failure was the aft flex pack of the Kop-Flex coupling, which sheared as indicated in Figure 3.3. The mating sections of the failed aft flex pack are shown in Figures 3.6 and 3.7. The thin metal sheets on the interior of the pack were essentially shredded. Once again, the coarse material in the center of the flex pack pieces is the foam material used to secure the strain gages. The final point of failure was the neck of the spline shaft adapter connecting the driveshaft to the compressor shaft. This location is indicated in Figure 3.3. The neck of the spline shaft adapter failed in torsion, and the six (6) ¼ inch - 28 bolts securing the spline shaft adapter to adapter 1 and the forward end of the Kop-Flex coupling were sheared. Figure 3.8 shows a photograph of the portion of the adapter still connected to adapter 1 and the Kop-Flex coupling. The spline portion of the spline shaft adapter and bolts remained in the compressor main shaft, as shown in Figure 3.9. These were easily removed with no apparent damage to the female spline in the compressor shaft.

The spline portion of the spline shaft adapter removed from the compressor main shaft is shown in Figure 3.10. The fracture surface was inspected under 10X magnification, Figure 3.11. No striations indicative of cyclic loading were visible. Therefore, the failure was apparently a result of a single overload. Some ductile deformation, seen in Figure 3.8, occurred prior to final brittle fracture.

3.1.2 Inspection and repair of facility drive system.

The facility drive system was inspected for damage. The end of the high speed jackshaft that mated with the driveshaft assembly has a precision female rabbet measuring 3.600/3.6016 inches diameter. The rabbet had been worn out to approximately 3.680 inches, depending on where the measurement was taken. This section of the high speed jackshaft was removed for repair. The labyrinth seal was removed and found to have rubbed against the high speed jackshaft. The damage was minor and repairable.

The high speed jackshaft was checked for straightness. Radial runout near the end of the shaft was less than 0.0005 inch, within tolerance. Axial runout on the flange was

also checked and was found to be approximately 0.001 inch. This could be attributed to axial movement of the drive system rather than a distorted flange and was also considered within tolerance.

The no. 1 pedestal bearing was checked. This bearing has approximately 0.006 inch clearance. During testing, greater than 0.010 inch vibrations were indicated. No visible damage to the bearing could be seen. The calibration of the proximeter probe measuring these vibrations was checked and found to be within tolerance. Due to the nature of the failure, no inspections were performed on the high speed gearbox or the low speed gearbox.

The damaged areas of the drive system were repaired. The rabbet end of the high speed jackshaft was welded using AMS 4130 to build up the damaged surface and machined to original tolerances. The rubbed labyrinth seal was cleaned up. The pads on the no. 1 pedestal bearing were replaced as a precautionary measure due to the high vibrations experienced during testing. The drive system was reassembled and a no-load test was performed. No problems were indicated during testing. A new Kop-Flex coupling was designed and ordered.

3.1.3 Inspection of TESCOM compressor.

The compressor was boroscoped through the front end and through a laser window port. The boroscope revealed that rotor 1 had rubbed the abradable material on the case, concentrating on the bottom of the compressor. No rubs could be seen on rotor 2 or on stators 1 and 2. No damage could be seen to the rotor blades or stator vanes from the boroscope. The oils were turned on and the compressor was boroscoped through the exit flow path inside the rotor hub to determine if the carbon seals were damaged. No oil leaks were found. The compressor was spun by hand; the main shaft bearings were damaged so that grinding was audible as the compressor was turned.

The TESCOM case was removed and visually inspected. Rotor 1 showed a substantial rub which removed a significant amount of the abradable coating applied to the case at that location. Stator 1 exhibited a minor rub that appeared to remove only high spots off the abradable material on the compressor hub at the stator location. No

damaged blades or vanes were found on either rotor or stator. The bearing package was disassembled and inspected. Carbon deposits were found on the forward carbon seal runner of the bearing, indicative of a hard rub, but there was no damage to the seal runner. The forward and rear bearings were visually inspected and found to have chatter marks on the race. New bearings and carbon seals were used in the compressor rebuild. No damage to the main shaft was found.

3.2 Data analysis.

Measurements from the test compressor and the drive system were recorded as analog signals during the two attempted runs to MIN SPEED. These included 3 accelerometers, 2 proximity probes, 4 strain gages on rotor 2, 2 Kulite pressure transducers, the gearbox 1/rev signal, and the test article 1/rev signal. One of the accelerometers was too noisy to obtain useful data. These signals were recorded on the Racal Storeplex, an analog to digital recorder based on the VHS tape format. In addition, drive system health monitoring measurements recorded as analog signals included 23 proximity probes, of which 14 were radial, 8 were axial, and 1 was for speed. These signals were recorded on a Datatape System 80 Instrumentation Tape Recorder. The signals from the Storeplex and the tape recorder were plotted on the Gould TA6000 Thermal Array Recorder and digitized on the Analog Data Analysis (ADA) computer during playback. The plots and digital data thus generated were then analyzed.

As previously discussed, proximity probes on the jackshaft indicated high vibrations indicative of a shaft critical speed at approximately 6150 rpm. The responses from one of these probes are shown for both MIN SPEED runs in Figure 3.12. The amplitude of the vibration at the shaft 1/rev frequency was approximately 7.75 mils during the acceleration phase of the first run and approximately 10 mils during deceleration. In both cases, the vibration amplitude was well above the alarm limit of 5 mils set for the test. Moreover, the maximum amplitude of the proximity probe increased with each successive transit through this critical, indicating cumulative damage to the spacer/coupling. This result demonstrates that damage initially occurred during the first

MIN SPEED run. The driveshaft assembly passed through this critical three times before failure.

Data from the second MIN SPEED run indicated that the failure consisted of two distinct events. The time histories of several pertinent signals are shown in Figure 3.13 to confirm this. During the acceleration to minimum speed, accelerometer and proximity probe signals began to rise steadily during the period from -2 seconds to 0 seconds. During this same period, test compressor and drive system speeds were synchronous at approximately 6100 to 6150 rpm. Compressor accelerometers and proximity probe signals all indicated a maximum of approximately 5 mils p-p displacement. Drive system proximity probes near the jackshaft blossomed sharply to over 15 mils p-p. Facility monitoring computers only detected 10 mils p-p (Figure 2.2) because the blossom occurred too rapidly to be accurately computed with fast Fourier transform techniques used in the data processing algorithm. All of the instrumentation signals were dominated by the 1/rev frequency.

At approximately 0 seconds, the signals from all of the probes changed abruptly. During this event (referred to here as Event #1), the compressor proximity probe signals exceeded 10 mils and the accelerometer signals dropped to below 1.5 mils. Drive system proximity probe signals dropped but continued to remain relatively high, indicating a steady cyclic displacement of approximately 5 mils p-p. Drive system speed and test compressor speed remained synchronous at approximately 6,150 rpm. While the 1/rev frequency continued to dominate in the accelerometer signals, the dominant frequency from proximity probes on the compressor and jackshaft shifted to about 0.5 or 0.4/rev.

Approximately 3 seconds after Event #1, the programmable logic computer initiated an E-STOP and the compressor began to decelerate linearly from 6,250 rpm at a rate of approximately -70 rpm/sec. Twenty-two seconds later, at a time of 25 seconds and speed of 4700 rpm, the signals again changed abruptly. During this event (referred to as Event #2), the accelerometer signals blossomed briefly to a maximum of about 11 mils p-p and dropped to below 0.5 mils thereafter. Compressor proximity probe signals dropped to below 5 mils p-p, and drive system proximity probe signals dropped to below 1 mil p-p. The 1/rev frequency once again began to dominate in all the signals. Immediately

after this event, the drive system and compressor speeds began to diverge, with the drive system decelerating at approximately -35 rpm/sec and the compressor decelerating at a slightly faster rate of about -40 to -50 rpm/sec. Both the drive system and compressor spun down uneventfully from this point at different rates.

The data shown in Figure 3.13 indicates that the failure began with Event #1 at 0 seconds. At that point, the flex pack on the aft end of the Kop-Flex coupling began to fragment. For approximately 25 seconds, or 1100 to 1250 cycles according to the proximity probes, the damaged flex pack introduced a severe imbalance to the system, causing a subsynchronous backward-traveling whirl as evidenced by the 0.5/rev frequency in the proximity probe signals. After 25 seconds, Event #2 occurred. The flex pack joint failed entirely, leading to the failures at the spline shaft adapter and at the interface between the 9-inch spacer and the jackshaft. Once decoupled, the test article and drive system coasted down separately to 0 rpm. Since the driveshaft assembly served as the strain gage wireway, strain gage leads were broken and strain gage signals were lost when the driveshaft assembly failed.

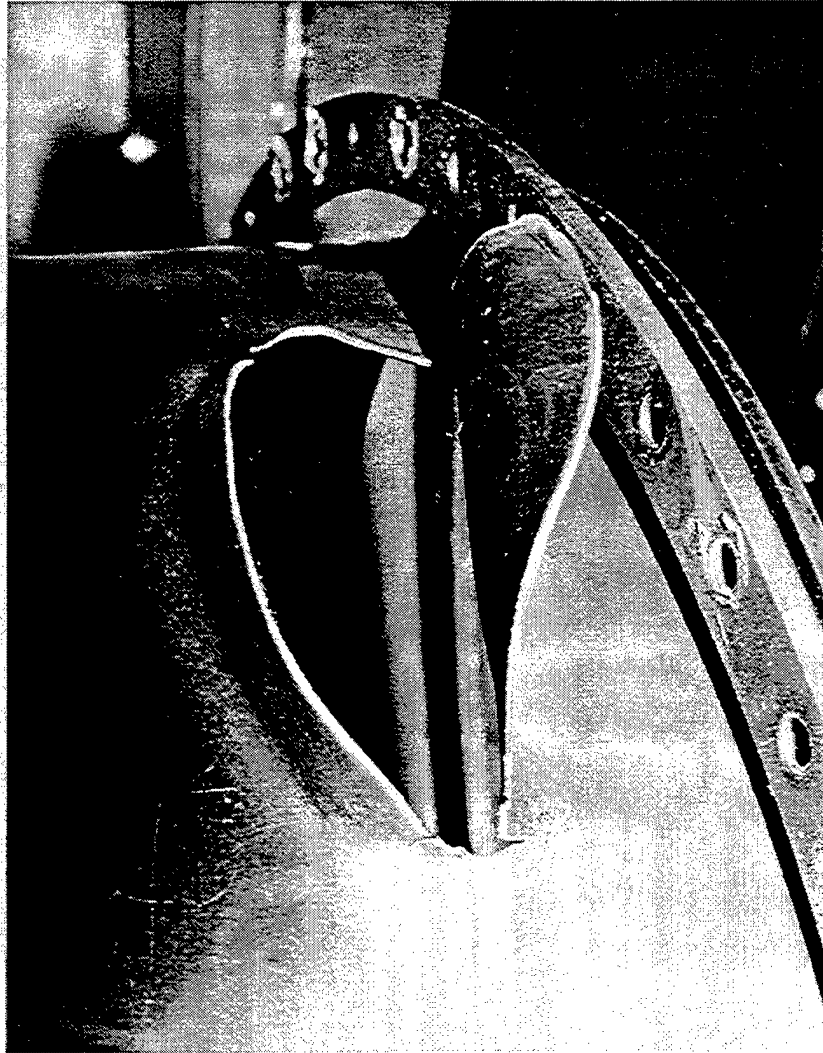

Figure 3.1. Photograph of hole in inner exit flow path.

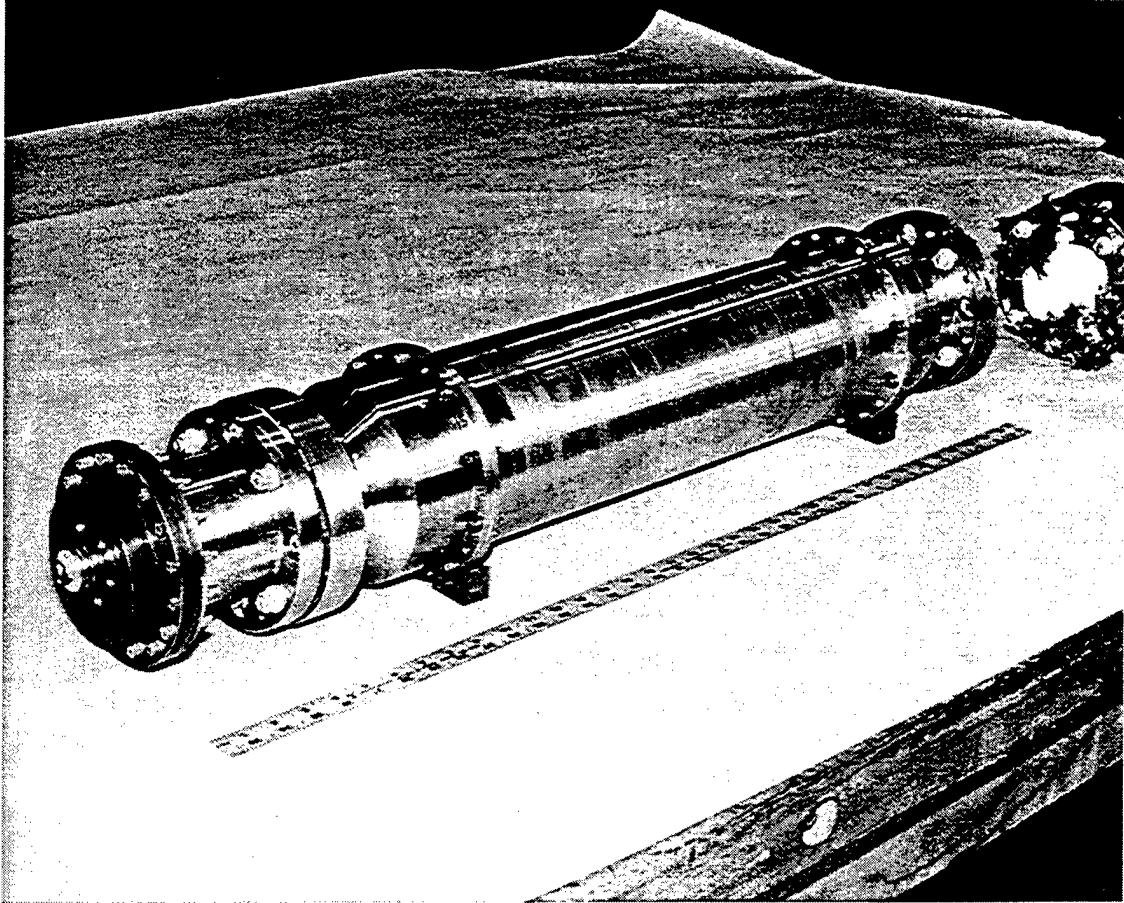

Figure 3.2. Photograph of driveshaft assembly pieces recovered from inner exit flow path.

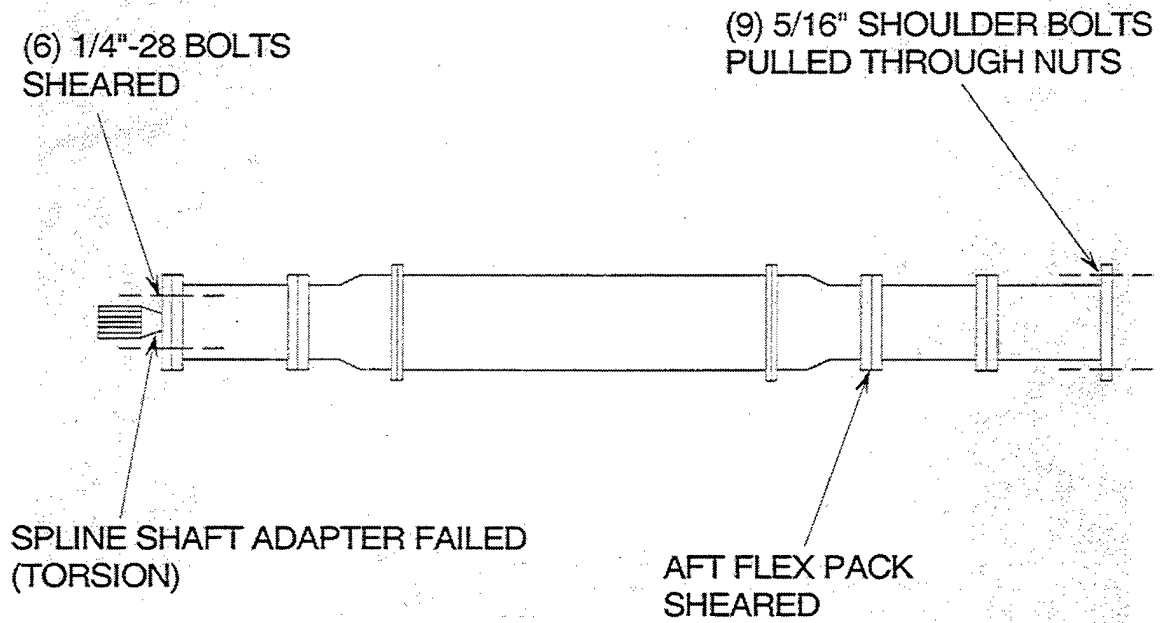

Figure 3.3. Driveshaft assembly failure points.

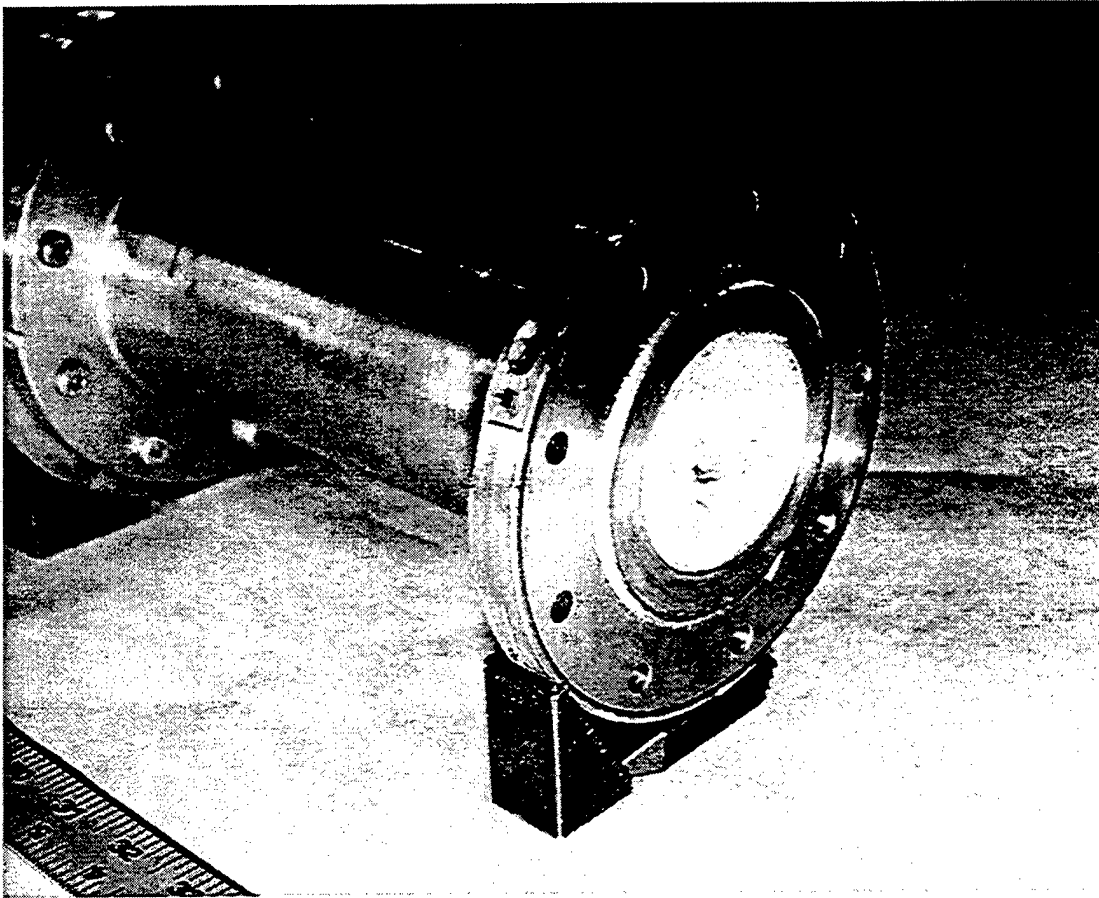

Figure 3.4. 9-inch spacer at jackshaft interface.

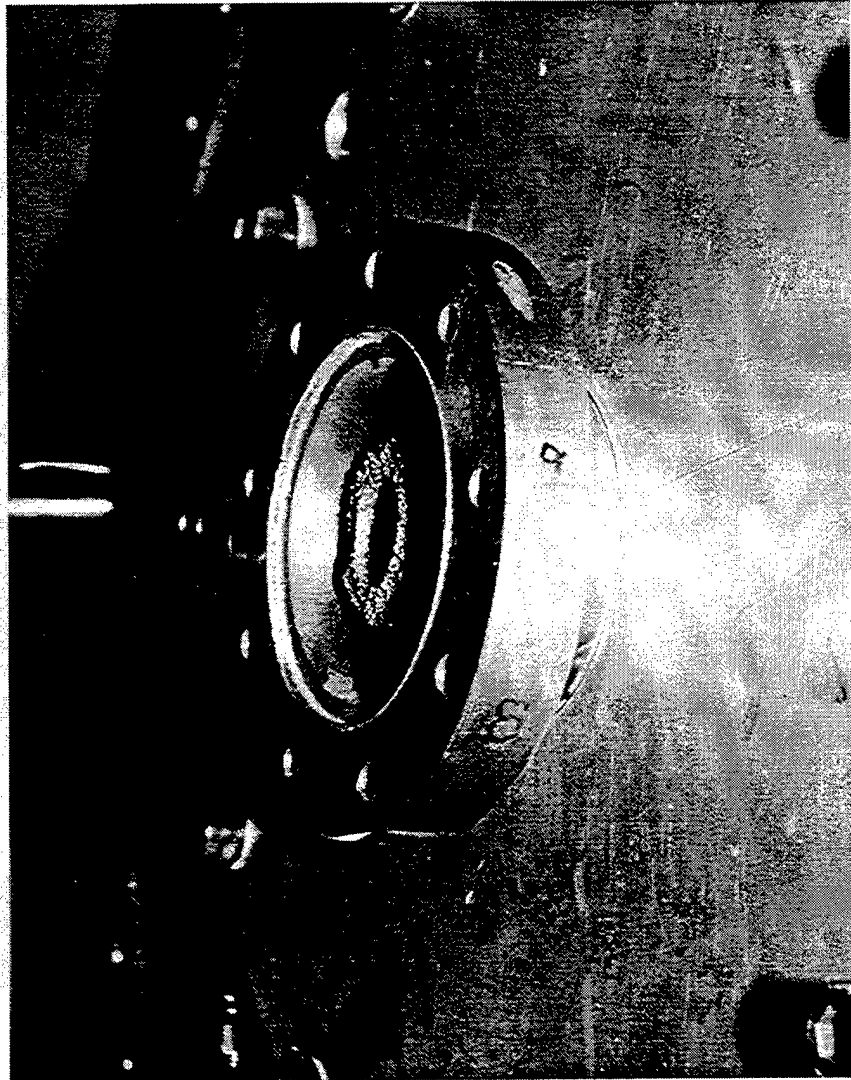

Figure 3.5. High speed jackshaft at driveshaft assembly interface.

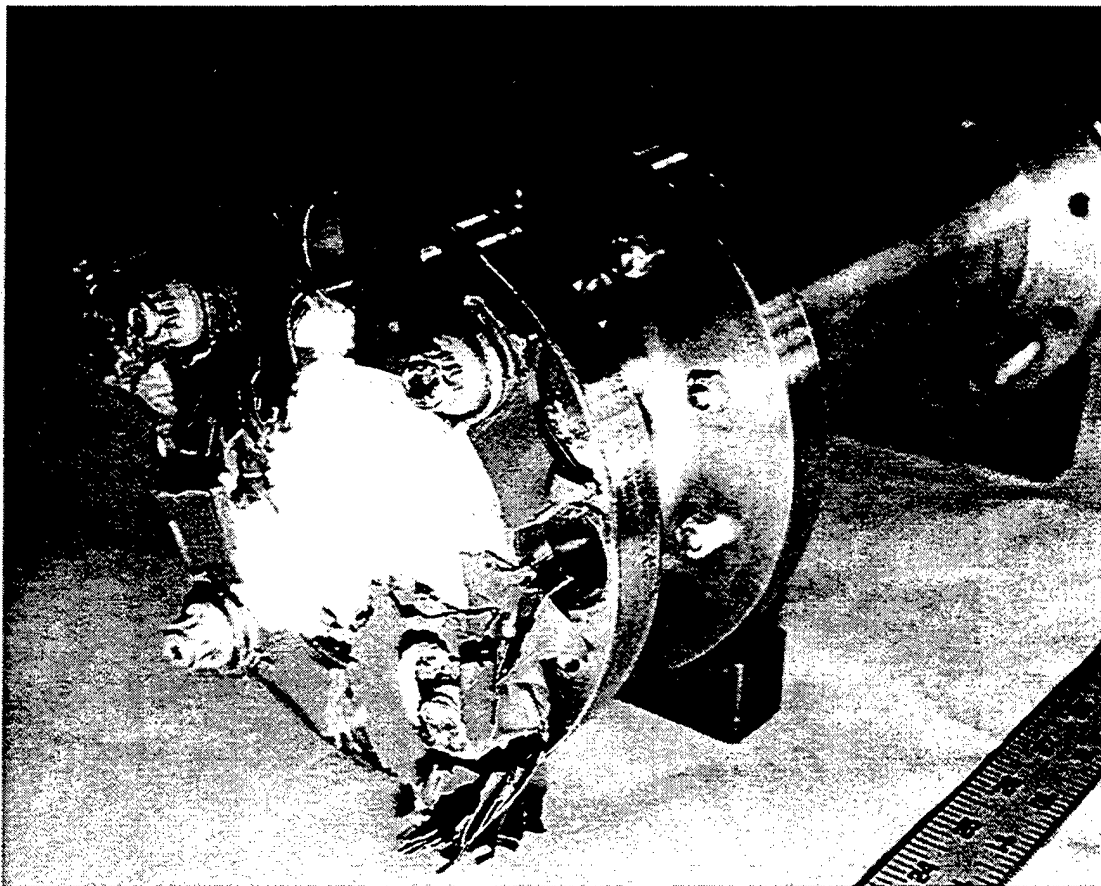

Figure 3.6. Aft end of failed flex pack.

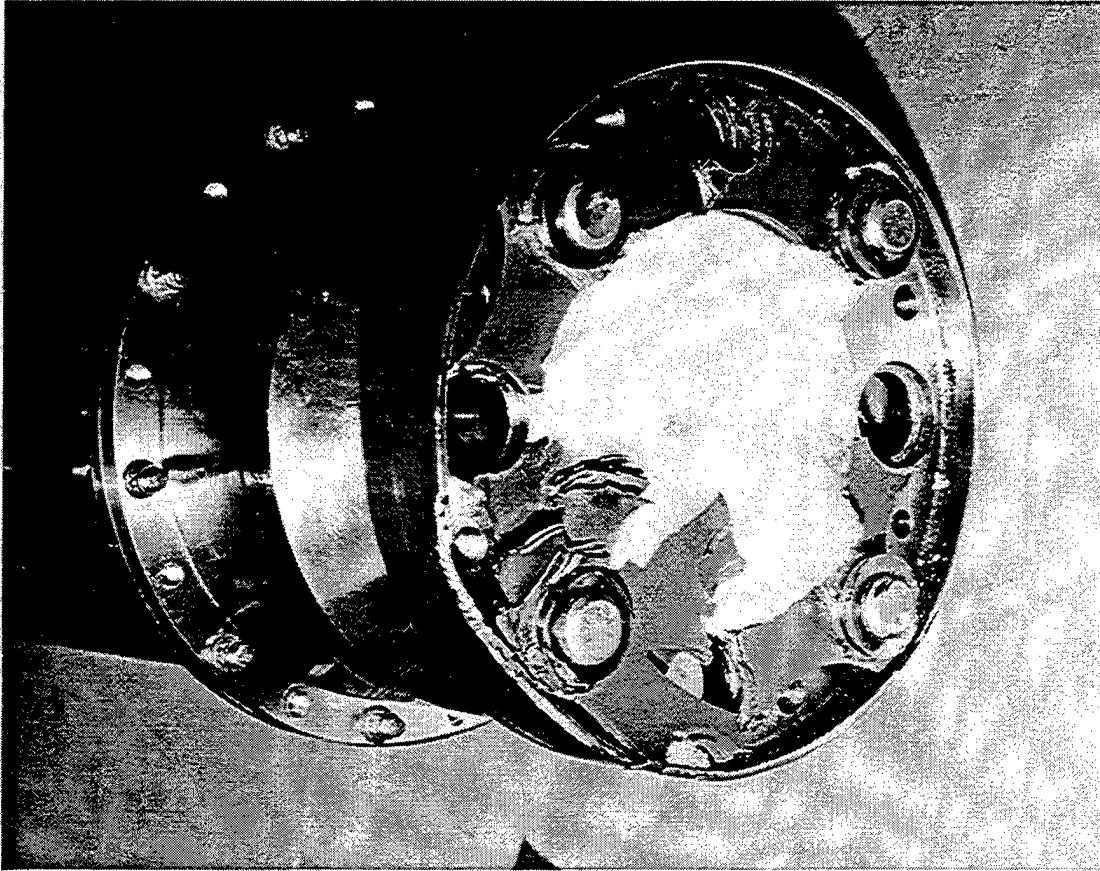

Figure 3.7. Forward end of failed flex pack.

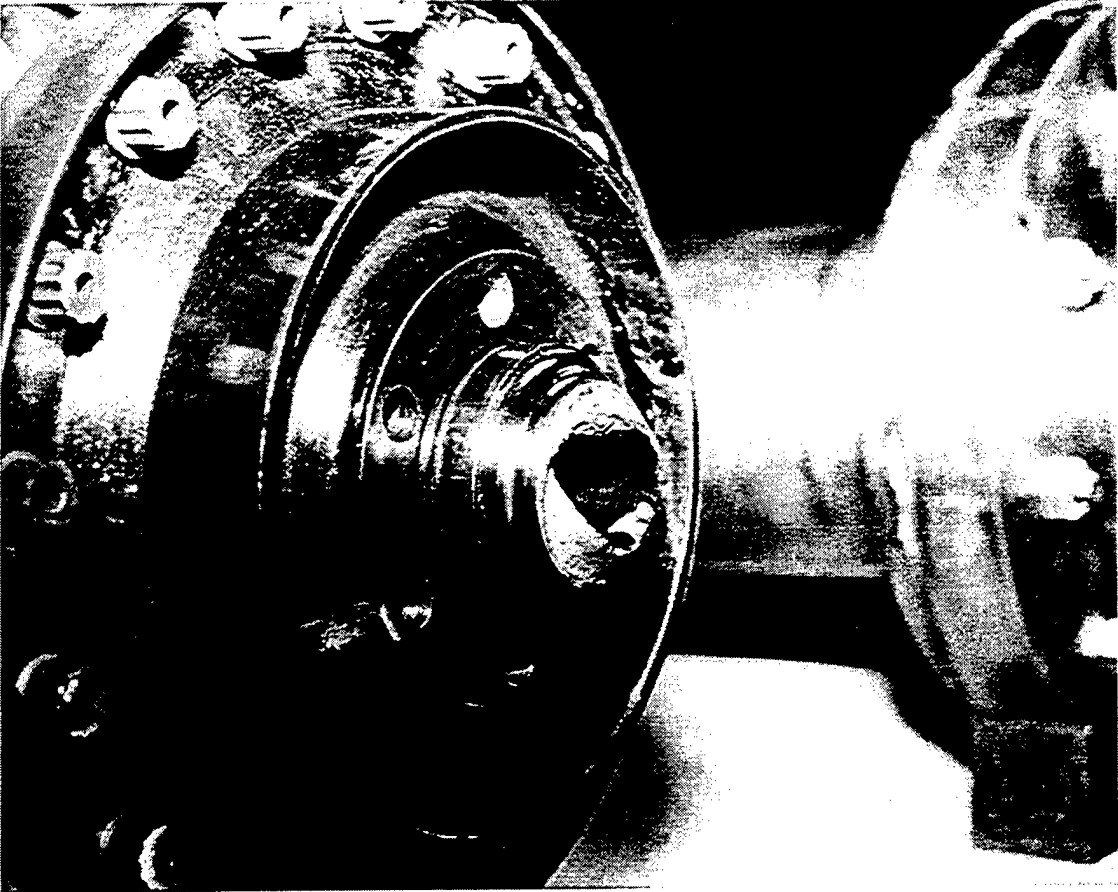

Figure 3.8. Aft portion of failed spline shaft adapter which remained with the drive system assembly.



Figure 3.9. Spline portion of the spline shaft adapter and bolts in compressor main shaft.

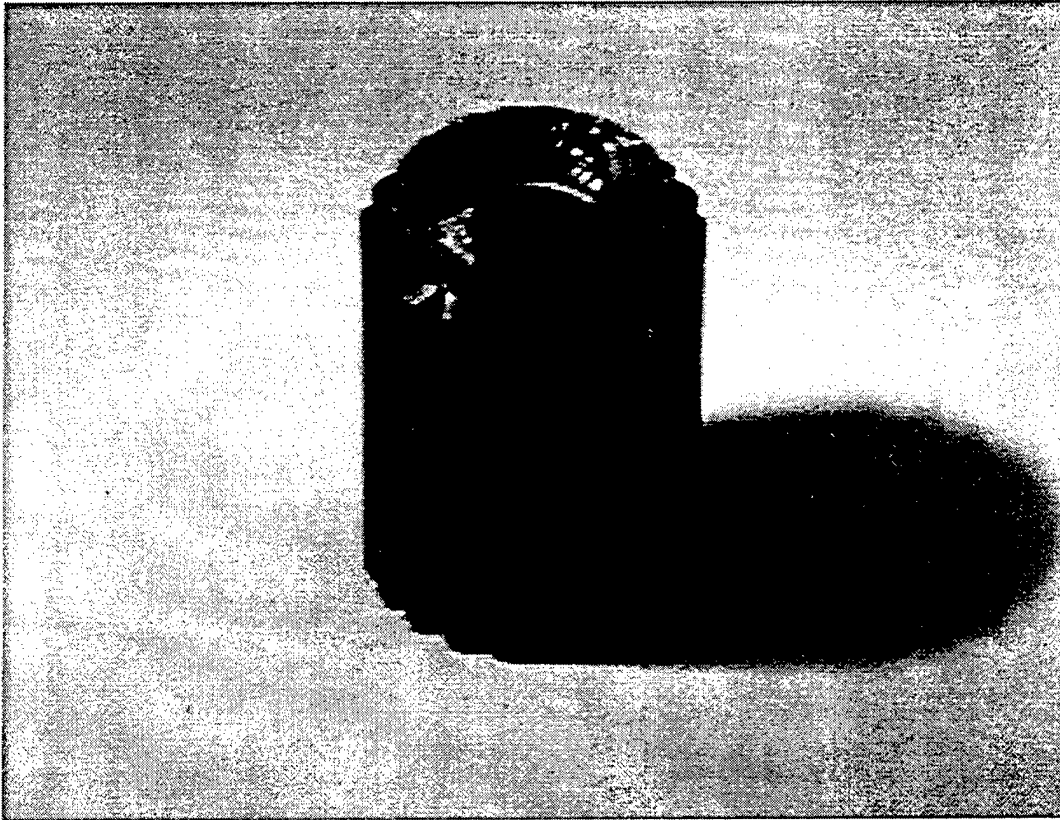

Figure 3.10. Spline portion of the spline shaft adapter.

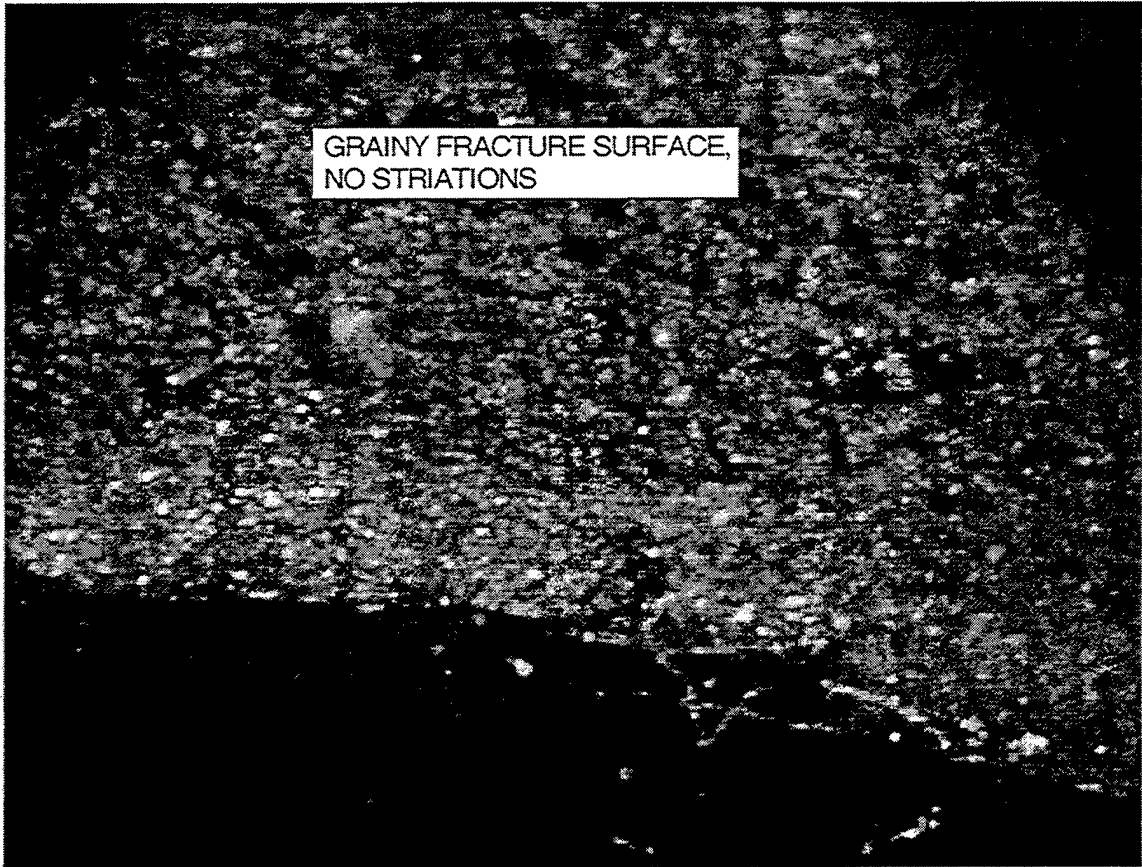
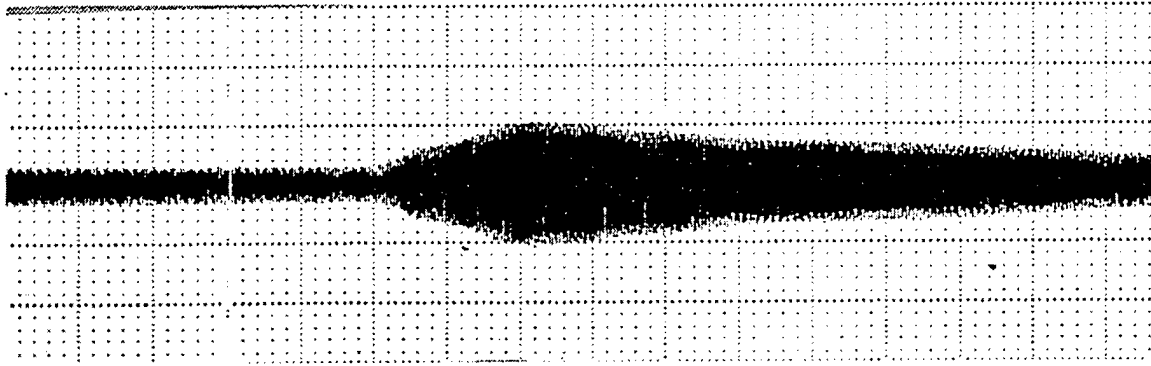
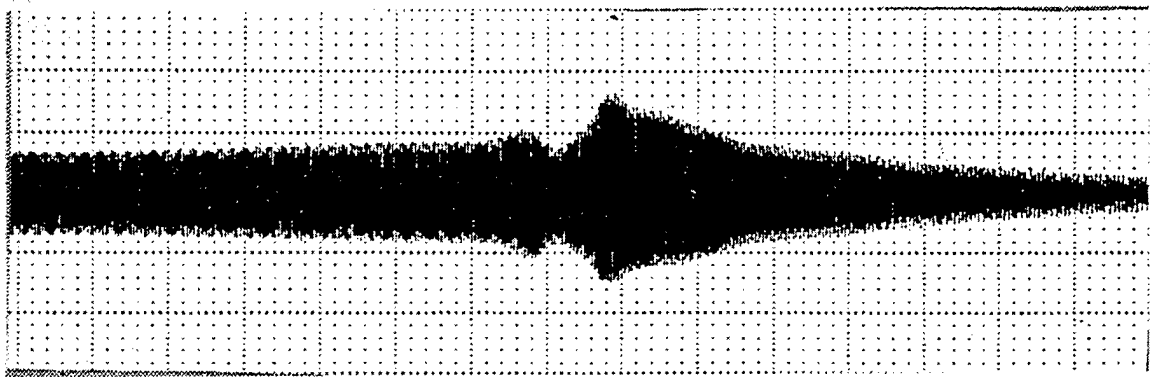

Figure 3.11. Fracture surface of the spline shaft adapter under 10X microscope.



Run 1, Accel



Run 1, Decel

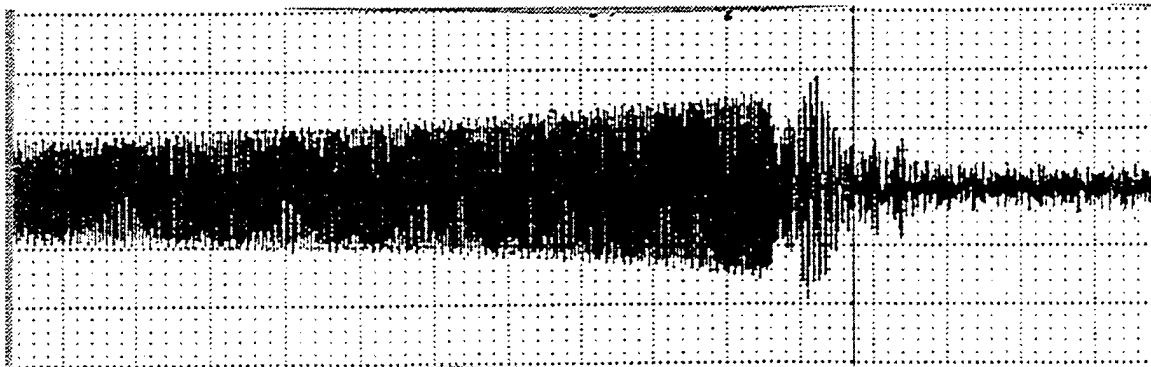

Run 2, Accel

Figure 3.12. High speed jackshaft proximity probe time histories showing amplitude increase with each pass.

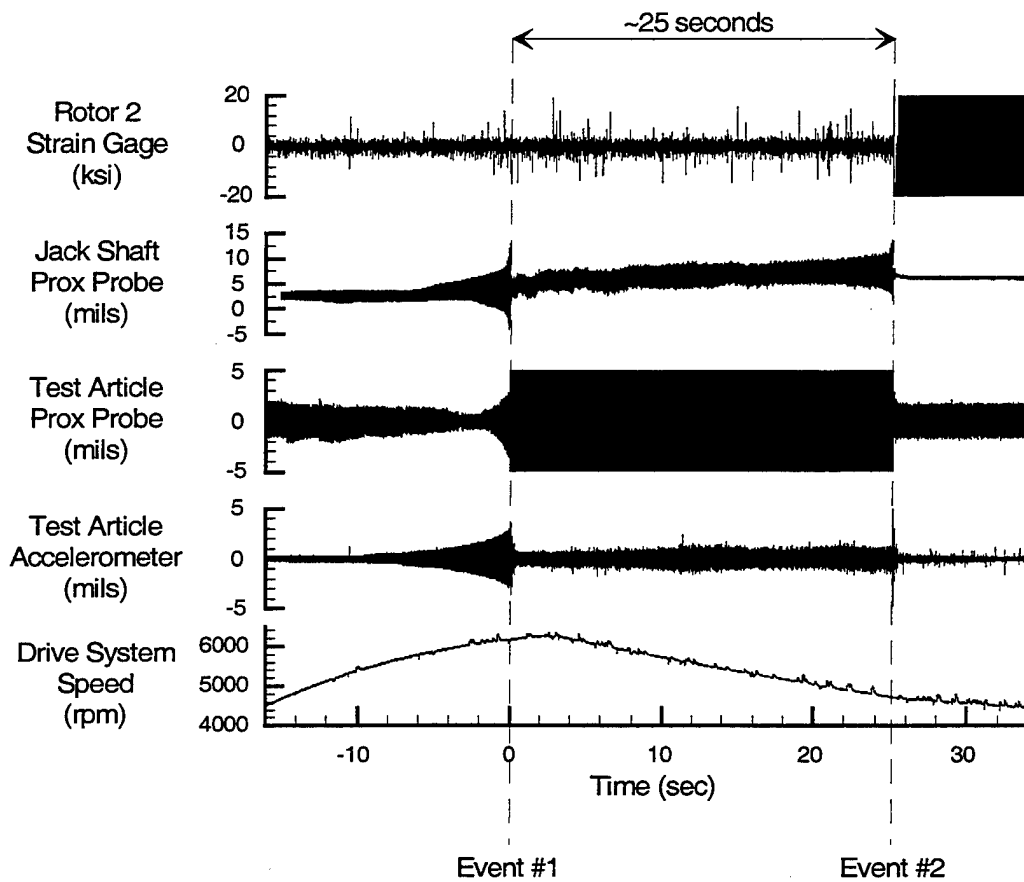

Figure 3.13. Time histories of pertinent transducers.

4.0 Findings and Conclusions

Failure of the aft flex pack of the TESCO driveshaft assembly apparently started during the first attempt to operate the test compressor at MIN SPEED. The amplitude of vibration was higher during the second pass through the shaft critical speed as the compressor was decelerating than it was during the first pass through the critical speed when the compressor was accelerating. Such a change in vibration amplitude is often indicative of damage, particularly crack propagation. The aft flex pack did not fail completely during the first MIN SPEED run, but it likely sustained significant damage. This observation is supported by data from the second acceleration to MIN SPEED, during which the shaft made a third and final pass through the critical speed. Once again, the vibration amplitudes were higher than during the previous two passes, indicating further damage had occurred to the aft flex pack. No inspection of the driveshaft assembly was made between the two MIN SPEED runs, so the damage from the first run was undetected prior to the second run during which the complete failure occurred. Moreover, the high vibrations encountered during the first run, which exceeded alarm levels, were not addressed until review of the driveshaft failure.

From the data presented, the failure probably initiated at the aft flex pack, which began to whirl off-axis. Initiation of this subsynchronous whirl and the severe imbalance it caused corresponds to Event #1 described in Section 3.2. The whirl produced the 0.5/rev frequency noted in the data from the proximity probes. The whirl also pulled the bolts at the connection point between the high speed jackshaft and the 9-inch spacer. After 25 seconds in this state, the flex pack failed entirely, corresponding to Event #2 described in Section 3.2. The weight of the coupling fragment and spacer finished pulling the bolts from the jackshaft, allowing these pieces to fall to the bottom of the inner exit flow path. In addition, the angular momentum of the Kop-Flex coupling apparently snapped off the spline at the neck of the spline shaft adapter when the flex pack suddenly failed. At some point during the failure, the whirling end of the Kop-Flex coupling likely struck the wall of the inner exit flow path, resulting in the gash. Finally,

the Kop-Flex coupling came to rest at the bottom of the inner exit flow path. After the driveshaft assembly had become detached, the test article and facility drive were separated, allowing the two to coast down at different speeds. Rotor blade tip rub was not likely to be a factor in the driveshaft failure. Instead, the imbalance caused by the driveshaft assembly failure must have caused the blade tip rub and compressor bearing damage.

Based on the physical evidence and data presented in Section 3 of this report, the driveshaft coupling appears to have failed as a result of an unexpected shaft critical speed at approximately 6150 rpm. This speed corresponds to a shaft natural frequency of approximately 103 Hz excited by a 1/rev excitation. No criticals were indicated at that frequency by the coupling manufacturer. The coupling was rated by the manufacturer for a maximum speed of 22,200 rpm, with its first natural frequency predicted in a flexural mode at 41,100 rpm. However, addition of the 9-inch spacer as described in Section 1.3 occurred after delivery of the coupling from the manufacturer, and no analysis was performed to determine the effect of the spacer on the dynamic characteristics of the coupling. With the addition of a significant mass at the end of the coupling and a change in the coupling boundary conditions, the first natural frequency of the coupling was lowered into the compressor operating range. Any imbalance in the system could provide the prescribed 1/rev excitation, leading to a strong resonance that overstressed the coupling flex pack. The two passes through the resonance during the first MIN SPEED run damaged the flex pack so that it could not withstand the stress during the third and final pass through the critical speed, and the coupling subsequently failed.

5.0 Recommendations

The TESCOM driveshaft assembly failure was apparently caused by an unexpected shaft natural frequency in the compressor operating range. To avoid future incidents like this, more care should be taken to verify all drive system natural frequencies. This is especially true if any changes are made in the drive system configuration, such as the 9-inch spacer added to the TESCOM driveshaft assembly, or if rotor dynamics data obtained during testing indicates any unexpected behavior in the drive system. The most efficient and accurate means of determining shaft natural frequencies is an impulse test using portable equipment currently available in the Turbine Engine Fatigue Facility (TEFF). This equipment is capable of computing the frequency response function (transfer function) of the shaft installed in the test chamber as it is excited by an impulse. The capability to perform this procedure has become available since the time of the failure, and may now be used with little impact on compressor testing.

Much of the damage sustained during the driveshaft failure could have been avoided if the damage to the aft flex pack during the first MIN SPEED run had been noticed. Two conditions occurred during the first MIN SPEED run which should have resulted in an investigation of the drive system. The first was drive system vibrations in excess of alarm limits during the acceleration and subsequent deceleration through the critical speed. Such overstress on a driveshaft assembly can result in significant damage. The second condition was the increase in vibration amplitude between subsequent passes through the critical speed. Whenever a shaft critical speed is encountered multiple times, such as during acceleration and subsequent deceleration, an increase in vibration amplitude in later passes can indicate damage. For future tests, vibration levels should be monitored closely to determine if such changes occur. If vibrations exceed alarm limits or vibration amplitudes increase during subsequent passes through a critical speed, the shaft should be visually inspected for damage, and a ping test as described above should be conducted to determine if changes in shaft natural frequencies have taken place. Any

change in shaft natural frequency may indicate damage, and the driveshaft should be disassembled and inspected, with damaged parts repaired or replaced as necessary.

The underlying reason for the oversight in investigating the high vibrations during the first MIN SPEED run is the perception that operating speeds below MIN SPEED are safe. This is highlighted by the emergency actions initially coded in the programmable logic computers for the TESCO program. For high vibrations in the drive system, the response was to go to MIN SPEED. In the case of high vibrations below MIN SPEED, this can actually force the compressor to accelerate and thereby exacerbate the problem. Although it could not be determined from the data whether a MIN SPEED command was issued by the computers during the TESCO test, the driveshaft assembly failure demonstrates that the perception of safety below MIN SPEED is erroneous. No speed range should be considered a safe operating condition until it has been demonstrated as such. This practice is generally followed for speeds above MIN SPEED, but speeds below MIN SPEED should also be demonstrated. This can be accomplished by modifying test procedures during mechanical checkout to allow for problems in low speed ranges. For instance, high vibrations at speeds below MIN SPEED should result in an E-STOP command from the programmable logic computers rather than the MIN SPEED command. This practice has been adopted for further TESCO testing and should likewise be adopted for future tests in the CRF.

The TESCO compressor and driveshaft assembly have been reassembled using a redesigned Kop-Flex coupling to eliminate the need for a spacer, and testing has again commenced. The recommendations of this report have been adopted for the remainder of the TESCO program. Vibrations are being monitored more closely, with amplitudes in excess of alarm levels or increases in amplitude resulting in investigation of the driveshaft, including visual inspection and impulse testing. Furthermore, the programmable logic computer emergency actions have been reprogrammed to initiate an E-STOP command if high vibrations occur below MIN SPEED. These standards should result in a more successful TESCO program and should be adopted for future programs as well.

6.0 References

1. Law, C.H., Design of a 1250 ft/sec, Low-Aspect-Ratio, Two-Stage Axial-Flow Compressor, AFWAL-TR-83-2027, Air Force Wright Aeronautical Laboratories, Wright-Patterson AFB, Ohio, May 1983.
2. Law, C.H., and Wennerstrom, A.J., Design of a 1250 ft/sec, Low-Aspect-Ratio, Single-Stage Axial-Flow Compressor, AFAPL-TR-79-2096, Air Force Aero Propulsion Laboratory, Wright-Patterson AFB, Ohio, December 1979.
3. Law, C.H., Investigation of a High-Stage-Loading Low-Aspect-Ratio Single-Stage Compressor (TESCOM Configuration 1A), AFWAL-TR-83-2016, Air Force Wright Aeronautical Laboratories, Wright-Patterson AFB, Ohio, April 1983.
4. Comey, D.H., and Hayes, J.M., Axial Compressor Performance Improvement Program, AFAPL-TR-79-2105, Air Force Aero Propulsion Laboratory, Wright-Patterson AFB, Ohio, January 1980.
5. Law, C.H., Investigation of a High-Stage-Loading Low-Aspect-Ratio Single-Stage Compressor (TESCOM Configuration 1B), AFWAL-TR-82-2131, Air Force Wright Aeronautical Laboratories, Wright-Patterson AFB, Ohio, February 1983.