

AFRL-VS-HA-TR-98-0008

LOW FREQUENCY RADIO RESEARCH AT THULE, GREENLAND

A. C. Fraser-Smith
C. C. Teague

Stanford University
Space, Telecommunications and Radioscience Laboratory
Stanford, CA 94305

January 1998

Final
1 April 1993 – 31 July 1997

DISTRIBUTION STATEMENT A
Approved for Public Release
Distribution Unlimited



AIR FORCE RESEARCH LABORATORY
Space Vehicles Directorate
29 Randolph Road
AIR FORCE MATERIAL COMMAND
HANSCOM AFB, MA 01731-3010

DTIC QUALITY INSPECTED 1

19990323 043

"This technical report has been reviewed and is approved for publication."

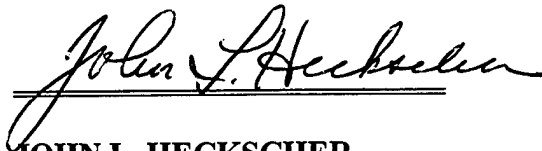

JOHN L. HECKSCHER
Contract Manager

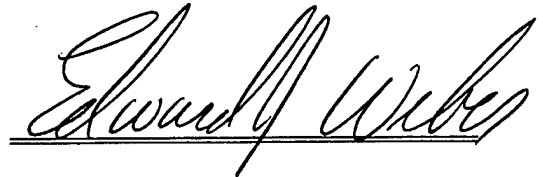

EDWARD J. WEBER, Chief
Ionospheric Hazards Branch

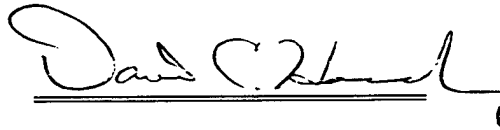

DAVID A. HARDY, Acting Chief
Battlespace Environment Division

This report has been reviewed by the ESC Public Affairs Office (PA) and is releasable to the National Technical Information Service (NTIS).

Qualified requestors may obtain additional copies from the Defense Technical Information Center (DTIC). All others should apply to the National Technical Information Service (NTIS).

If your address has changed, if you wish to be removed from the mailing list, or if the addressee is no longer employed by your organization, please notify AFRL/VSOS-IM, 29 Randolph Road, Hanscom AFB, MA 01731-3010. This will assist us in maintaining a current mailing list.

Do not return copies of this report unless contractual obligations or notices on a specific document require that it be returned.

REPORT DOCUMENTATION PAGE

Form Approved
OMB No. 074-0188

Public reporting burden for this collection of information is estimated to average 1 hour per response, including the time for reviewing instructions, searching existing data sources, gathering and maintaining the data needed, and completing and reviewing this collection of information. Send comments regarding this burden estimate or any other aspect of this collection of information, including suggestions for reducing this burden to Washington Headquarters Services, Directorate for Information Operations and Reports, 1215 Jefferson Davis Highway, Suite 1204, Arlington, VA 22202-4302, and to the Office of Management and Budget, Paperwork Reduction Project (0704-0188), Washington, DC 20503

1. AGENCY USE ONLY (Leave blank)	2. REPORT DATE January 1998	3. REPORT TYPE AND DATES COVERED Final (1 April 1993-31 July 1997)	
4. TITLE AND SUBTITLE Low Frequency Radio Research at Thule, Greenland		5. FUNDING NUMBERS PE 63402F PR 4029 TA GJ WU AA Contract F19628-93-K-0002	
6. AUTHOR(S) A. C. Fraser-Smith C. C. Teague			
7. PERFORMING ORGANIZATION NAME(S) AND ADDRESS(ES) Stanford University Space, Telecommunications and Radioscience Laboratory Stanford, CA 94305		8. PERFORMING ORGANIZATION REPORT NUMBER	
9. SPONSORING / MONITORING AGENCY NAME(S) AND ADDRESS(ES) Air Force Research Laboratory 29 Randolph Road Hanscom AFB, MA 01731-3010 Contract Manager: John Heckscher/VSBI		10. SPONSORING / MONITORING AGENCY REPORT NUMBER AFRL-VS-HA-TR-98-0008	
11. SUPPLEMENTARY NOTES			
12a. DISTRIBUTION / AVAILABILITY STATEMENT Approved for public release; distribution unlimited		12b. DISTRIBUTION CODE	
13. ABSTRACT (Maximum 200 Words) The research reported here started in 1993 following Stanford University's submission of a basic research proposal in response to a February 1992 Broad Agency Announcement (BAA) issued by the Phillips Laboratory at Hanscom Air Force Base. The proposed research involved the upgrade of an ELF/VLF/LF "radiometer" constructed previously by Stanford University for Phillips Laboratory and located at Thule, Greenland, which is essentially at the center of the northern polar cap and which is therefore a unique location for the measurement of ELF/VLF/LF radio signals and noise (frequencies in the range 10 Hz -- 60 kHz). It was proposed that the system would be upgraded by the addition of a new computer with a Stanford-installed digital signal processing capability that would allow the amplitudes and frequency spectra of incoming low-frequency radio signals to be examined in real time either by experimenters on location at Thule or, with slightly less capability, at remote locations via telephone line. We report here the installation of the new computer with its new digital signal processing capability on a system essentially identical to the Thule system but located on the Stanford campus in California, where it was used for measurements during the first transmissions from HAARP, as well as transmissions from HIPAS, during early 1997.			
14. SUBJECT TERMS VLF radio signals ELF noise LF noise VLF noise LF radio signals		15. NUMBER OF PAGES 28	
		16. PRICE CODE	
17. SECURITY CLASSIFICATION OF REPORT Unclassified	18. SECURITY CLASSIFICATION OF THIS PAGE Unclassified	19. SECURITY CLASSIFICATION OF ABSTRACT Unclassified	20. LIMITATION OF ABSTRACT SAR

TABLE OF CONTENTS

Chapter

1. INTRODUCTION	1
2. UPGRADE OF THE THULE RADIOMETER	2
2.1. Computer Upgrade	3
2.1.1. First Stage of the Upgrade	3
2.1.2. Second Stage of the Upgrade	5
2.1.3. Final Stage of the Upgrade	8
2.2. Computer Interface Unit	10
3. EXPERIMENTAL MEASUREMENTS	11
3.1. Initial Preparations	11
3.2. The 1997 Campaigns	12
4. CONCLUSION	17
5. REFERENCES	20

ACKNOWLEDGEMENTS

This work was conducted under Department of the Air Force Contract No. F19628-93-K-0002, with technical management being provided by the Geophysics Directorate of the Phillips Laboratory; Mr. John Heckscher was the Scientific Program Officer. Professor Antony C. Fraser-Smith was the principal investigator. Mr. Paul R. McGill, now at the Monterey Bay Aquarium Research Institute (MBARI), provided important practical assistance at Stanford during the initial phase of the project.

1. Introduction

Department of the Air Force/Phillips Laboratory Contract No. F19628-93-K-0002, for which this is the final report, was first issued to the Space, Telecommunications and Radio-science Laboratory (the STAR Laboratory) at Stanford University on 1 April 1993 and the contract finally expired on 31 July 1997, after some no cost extensions. The primary objective of the work was to improve and extend the long wave radio communication capability of the Air Force through the modification and subsequent experimental operation of a highly sensitive receiver for radio signals in the ELF/VLF (10 Hz – 30 kHz) band.

The ELF/VLF/LF radio noise measurement system at Thule Air Base, Greenland, was first installed on South Mountain during August-September 1985. It is one of eight essentially identical systems that were constructed for the purpose of making a global survey of ELF/VLF (10 Hz – 32 kHz) radio noise [*Fraser-Smith and Helliwell, 1985; Fraser-Smith et al., 1988*]. The major support for the survey came from the Office of Naval Research, but Rome Air Development Center (RADC; now Rome Laboratory) provided funds specifically for the Thule system, which differed from the other systems only through the addition of a special variable filter unit that extended its frequency range of operation from an upper frequency of 32 kHz to a new upper frequency of 60 kHz.

With the important help of Mr. J. P. Turtle of RADC, the STAR Laboratory operated the Thule radiometer until 1991, when programmatic changes at RADC and lack of funds forced us to end its operation. During its six-year interval of operation, we obtained a large quantity of high-quality ELF/VLF/LF noise measurements for incorporation into our overall global survey. In addition, we obtained an extraordinarily valuable collection of measurements during at least six solar particle events (SPE's), including some of the largest SPE's to have occurred during the last three decades [*Fraser-Smith and Turtle, 1993*].

The noise survey ELF/VLF radiometers were designed during the early 1980's. They were intended to be "state-of-the-art" in every significant detail, and they incorporated a system computer in what was, at the time of their design, a most innovative manner. The computer not only computed the one-minute noise amplitudes that were the major component of the radiometer's data output, but it also completely controlled the operation of the system. Unfortunately, by 1992 the computer used in the radiometers was obsolete. Since the other

components of the radiometers were still in excellent condition and needed little modification to ensure that they were still “state-of-the-art,” we began looking for ways to upgrade the systems. As a result, in response to a February 1992 Broad Agency Announcement by Phillips Laboratory, we proposed a number of changes to the Thule radiometer including, in particular, the installation of a new computer that would give it greatly increased capability. Our proposal was accepted for funding, and on 1 April 1993 we commenced work on the upgrade.

In the following section we describe the upgrade of the existing Thule ELF/VLF/LF radiometer in greater detail (Section 2). We then detail measurements made during the HIPAS and HAARP campaigns of 1997 with the upgraded system (Section 3). We conclude with a brief summary (Section 4) and a list of references (Section 5).

2. Upgrade of the Thule Radiometer

The original Thule noise survey system (or radiometer) included the following major components:

1. A VLF receiver covering the frequency range 300 Hz to 32 kHz.
2. An ELF receiver covering the frequency range 10 Hz to 1 kHz.
3. A set of narrow band noise filters covering the range 10 Hz to 32 kHz.
4. An analog-to-digital (A/D) converter with a 48-channel multiplexer.
5. A mixer/monitor to format the analog VLF signal before it is recorded.
6. One or more analog tape recorders using 1/4-inch tape.
7. One or more digital tape recorders using 10-inch reels of 1/2-inch tape.
8. A clock for keeping system time.
9. A Data General MicroNova computer.
10. A video display terminal.
11. A control coupler which connects the computer to various system instruments.
12. A variable low-frequency (LF) filter unit, which extends the frequency range of operation of the radiometer to 30 – 60 kHz.

With the exception of the last of these items, which is specific to the Thule radiometer, detailed descriptions of the components can be found in the *ELF/VLF Noise Survey Software Reference Manual*, Ch. 1, prepared by Dr. E. Paschal at Stanford University, from which the above list was taken.

For the upgraded system, we proposed keeping the VLF and ELF receivers, noise filters, A/D converter, mixer/monitor, analog tape recorders, and control coupler, and replacing the clock and the computer and its associated digital tape recorders and display terminal.

2.1. Computer Upgrade and Interface Development

The computer upgrade and interface development took place in several stages, which we will now describe.

2.1.1. First Stage of the Upgrade

Although the Data General MicroNova computer used in our radiometers was a good choice at the time the original system was designed, it was apparent by the start of our contract that newer computer hardware and software would result in a system which would be much more flexible and easier to maintain. An attractive replacement for the computer controller was a Macintosh series computer because of the excellent software development tools available for those inexpensive computers. The software tools would allow us to write a radiometer control program that took full advantage of the powerful Macintosh user interface. We therefore purchased a Macintosh Quadra 800 computer immediately after the 1 April 1993 start of the contract, with 8 Mbytes of RAM and a 1 Gbyte hard disk (taking advantage of rapidly-decreasing memory prices, the RAM memory was later increased from 8 to 16 Mbytes to facilitate operation of the computer). We also purchased two digital signal processing (DSP) cards and a Magellan GPS satellite receiver. We had planned on using a NuBus interface card and real-time kernel software (A/ROSE) from Apple Computer, but when the order was placed we found that the interface card was no longer available. Fortunately, there were alternatives in the form of third-party external cards. In particular, a development system was available from Motorola that used their 68332 embedded controller, and Vesta Technology, Inc., provided a plug-compatible version using the same controller but with more memory and more convenient packaging. We ordered one of the Vesta controllers.

Following purchase of the above items, much of our effort was devoted to developing software for a reliable packet-based protocol for communication between the Macintosh Quadra, which was to be the overall controller for the upgraded radiometer system, and the external Motorola 68332 microprocessor, which was intended to handle the real-time data sampling,

time-keeping, and hardware configuration. We began running the communications software on the 68332 under an UCOS kernel, and we also began developing the software for the Macintosh using the Think C Class Library and the Apple Computer's Thread Manager (a multi-thread kernel for use within a single application). The communications link was an essential component of the overall system, because its function was to tie the otherwise independent Macintosh and 68332 processes together to form a single integrated system. A high-speed software downloading procedure developed during the preceding months was used extensively and it worked quite well during this development process.

Since our acquired Vesta Technology 68332 embedded controller included 1 megabyte of random-access memory (RAM), which was to be used for both program and data storage, the monitor program from the Motorola development system was modified slightly to allow the full 1 megabyte of memory to be accessed. This change was necessary because the Motorola software originally was designed for a much smaller address space. The modification was successful. The external circuitry required to access the existing filter and controller hardware to the 68332 controller was designed at this time.

A four-channel serial I/O controller card was obtained from Creative Solutions, Inc. That card, and a DSP card obtained from Spectral Innovations, were installed into the Quadra and both functioning normally. Preliminary discussions with Thom Stone at the NASA Ames Research Center indicated that it might be possible to get an Internet link to Thule, running the TCP/IP protocol. The feasibility of such an Internet connection depended on agreements between the Air Force and NASA, which were beyond our control, but the possibility of obtaining an Internet link was relevant since it would simplify our network hardware and software interface.

During this initial period of the upgrade, much effort was devoted to developing network communications capabilities for the control program running on the Macintosh Quadra. As we have indicated, there was a possibility of obtaining an Internet connection to our radiometer at Thule, although it was far from certain that the link could be obtained and the bandwidth of any such service was unknown. Faced by this uncertainty, several options were developed to deal with various possibilities for network connection. The first, and most desirable, was based on the Transmission Control Protocol (TCP), which is the standard

used on the Internet and on our local campus network. The software interface consisted of multiple telnet "sockets", to which other workstations on the Internet can connect using either a text-based or binary protocol. Various options existed for the hardware interface. The best was the ethernet hardware built into the Quadra and, if an Internet connection was available at all at Thule, the most likely connection would be ethernet. An alternative option was to encapsulate Internet packets in AppleTalk packets, if an AppleTalk connection was available. Finally, if neither ethernet nor AppleTalk was available, there was a possibility that a protocol called Serial Line Internet Protocol (SLIP) could be used, which runs over a dial-up modem connection at various speeds, preferably at least 9600 or 14,400 bps, but usable at 2400 bps.

A similar socket-based network capability, in both text and binary form, was implemented using AppleTalk protocols. While it was less likely that an AppleTalk link to Thule would be available, use of AppleTalk is convenient for local testing because of its widespread use on the Stanford campus. More importantly, the main control program was split into two major components, one of which collected data and managed the 68332 microprocessor, and the other part of which displayed data and accepted user commands. Communication between the two parts took place by using Apple Events (a standard Macintosh interapplication communication protocol). The Apple Event model was designed so that the sending and receiving entities did not need to be on the same computer, so that with very little additional work the command portion of the program could be running on a local machine at Stanford, or at another location such as Alaska, and the control portion of the program could be running at Thule. The user interface would look identical at Thule and at the remote sites. Of course, it would be necessary to establish an AppleTalk link between the two ends, but a software-only product from Apple called Apple Internet Router (AIR) was available which could provide transport of AppleTalk packets over an Internet link.

2.1.2. Second Stage of the Upgrade

The next stage of our upgrade was initially largely directed toward incorporation of the Vesta 68332 microprocessor into the computer system as a whole. Code for driving several of the timing functions was developed and debugged, including the synchronization of the A/D converter trigger pulses with the GPS signal (simulated on a Macintosh and in hardware).

The hardware interface between the 68332 and the existing filter and A/D converter hardware was also designed at this time.

Programming of the high-speed sampling to be undertaken by the digital signal processor (DSP) from Spectral Innovations was started, but it soon became apparent that in order to do the sampling and processing in real time we would need to write our own DSP software instead of using the software library supplied by Spectral Innovations with the DSP board. This necessitated a change in approach.

During this period, we studied a request for HAARP signal detection using long (20–30 minute) coherent integration times. In conjunction with this study, we explored the programming of the digital signal processor (DSP) hardware at the assembly-language level, using an assembler available from another project and for a slightly different DSP processor in the AT&T 3210 series.

Assuming that only a narrow band of frequencies was involved (on the order of a few Hz), a common approach would be to multiply the sampled data by a complex exponential to shift a portion of the original spectrum to near DC, low-pass filter the resulting data, re-sample the low-passed data to a much lower rate (say by a factor of 32), and possibly repeat the entire process with another reduction in sampling rate. What remained could then be analyzed with a conventional fast Fourier transform of manageable size (8-16 K points). The routines for frequency shifting, filtering and decimation, and Fourier transforming were all available as Macintosh-callable routines in the Array Processing Library provided by Spectral Innovations with the DSP board that we had, so the signal processing should be straightforward. This looked like a convenient solution to our original difficulty using the DSP board.

However, a problem still remained in the sampling of the raw data. While the signal processing routines for the DSP board would run concurrently with the Macintosh program (allowing other data collection and external communication to proceed during the filtering operations), the sampling routines, at least as supplied by Spectral Innovations, did not run concurrently but rather tied up the Macintosh for the duration of the data sampling (20–30 minutes). External data could not be transferred during this time, which was clearly unacceptable.

Some progress was made in programming DSP hardware similar to the DSP 32C in its assembly language, but it appeared that considerable effort would be required in order to use the DSP hardware in a real-time mode (where data samples are processed as they are received), and that it would require additional software to support the DSP 32C chip. However, it began to appear at this time that there might not be a need for real-time processing of the data, since the time to process the data appeared to be a small fraction of the time to record the data, so if the wide-band data could be stored to a local disk concurrently with other data collection, the wide-band data could be processed in just a few minutes. At worst, the wide-band data could be sampled independently of the DSP board and transferred to the DSP board for processing.

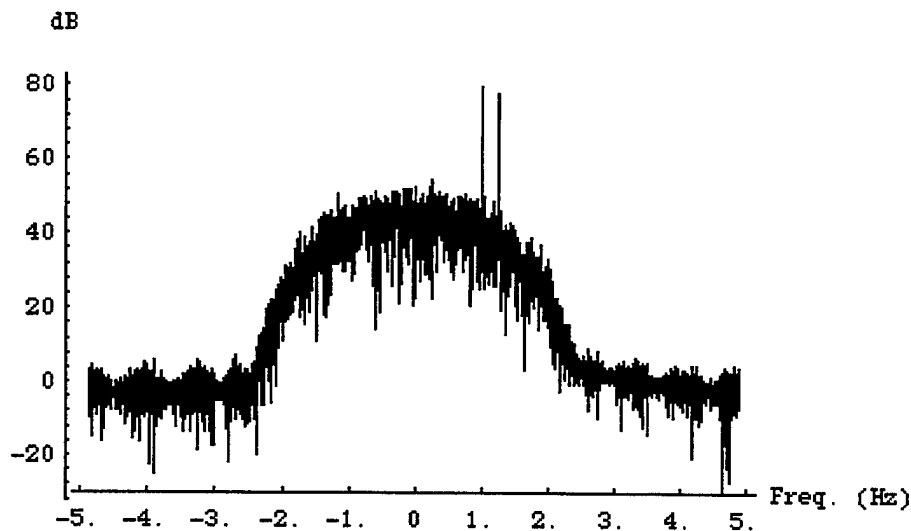

Figure 1. An example of cascaded frequency shifting, filtering, and decimation to detect two sine waves with frequencies of 2300.00 Hz and 2300.25 Hz in Gaussian noise covering the range 0–5 kHz. The original two sine waves clearly show up as signals at 1.0 and 1.25 Hz.

An example of this application of cascaded frequency shifting, filtering, and decimation is shown in Figure 1. For this example, data were simulated using a sampling frequency of 10 kHz, two unit amplitude sine waves at 2300.0 and 2300.25 Hz, and Gaussian noise with 10 units RMS amplitude in the full (0–5 kHz) bandwidth. Low-pass filters with a passband approximately 1/64 of the Nyquist frequency were used before each decimation by 32, and

two passes of shifting, filtering and decimation using the DSP board were applied. Finally, a 4096-point transform was done, covering a range of -4.88 to $+4.88$ Hz from a nominal center frequency of 2299.0 Hz. The original two signals show up at 1.0 and 1.25 Hz in the figure; they are clearly distinguishable from the immediate noise background, which has a level of about 40 dB. Equally important, outside of an approximately 4 Hz band centered on 0 Hz (the band containing our signals), the noise is suppressed to a level of about 0 dB – a 40 dB suppression. The resulting frequency bin spacing is 0.0024 Hz. The shape of the noise background reflects the shape of the 375-point Finite Impulse Response (FIR) low-pass filters used at each stage of the processing.

2.1.3. Final Stage of the Upgrade

The major effort during the period following the introduction of the method of data analysis described above was preparation of a high-speed data analysis program to run almost entirely on the Macintosh Quadra 800 computer. The processing that was adopted consists of the following: Following sampling of the data, the subsequent data processing involves (1) up to two stages of cascaded FIR filters (which in turn consisted of a complex mixer, a low-pass filter, and a sampling-rate decimation by up to about 32), (2) a Fourier transform on the resulting data stream (with a complex voltage output), (3) a power conversion, and (4) incoherent power averaging. The FIR filters are implemented using the MacDSP hardware, as is the FFT if its size is small enough to fit in the MacDSP memory. The Fourier transform can be applied to the raw data stream or to either of the FIR filter outputs, and any of the data streams can be selected for recording to disk. Note that if the raw data are recorded directly, no additional processing can be done; if the MacDSP A/D converter is used, it can only record to disk. If the raw data are recorded to disk, they can be played back many times with different processing parameters to search for specific signals of interest. Each FIR filter can reduce the effective sampling rate by a factor of about 32, so the pair can reduce the rate by 1024 (but of course only $1/1024$ of the total bandwidth is preserved). The FFT can examine the resulting bandwidth with at least 4096 bins using the DSP hardware, and probably up to 64K using a software transform, so the final FFT frequency bin bandwidth should be on the order of 10^{-7} to 10^{-8} of the input bandwidth. This capability satisfies the requirement for long coherent integration times on the order of minutes.

Following the adoption of the above data processing procedure, an Exabyte 8 mm helical-scan tape drive, model EXB-8505, was acquired and interfaced to the Macintosh Quadra 800 computer. Since an Exabyte EXB-8505 tape drive was also available on our group's Digital Alpha computer, data files could be exchanged between the two computers using a common tape format. In addition to the Retrospect backup software supplied with the tape drive, we also acquired software packages called "QuTape" and "IQTape." QuTape allows Macintosh disk files to be written to 8 mm tape in a variety of formats, including unlabeled binary, VMS Backup, and Unix tar; we can also use unlabeled binary for tape storage efficiency. IQTape includes a set of C-language drivers which can be called from a user-written program. Because QuTape is menu-driven and not scriptable through AppleScript, it would be useful only when an operator is present on site. The routines in IQTape, on the other hand, will be called from the Thule controller program and they will be available from AppleScript.

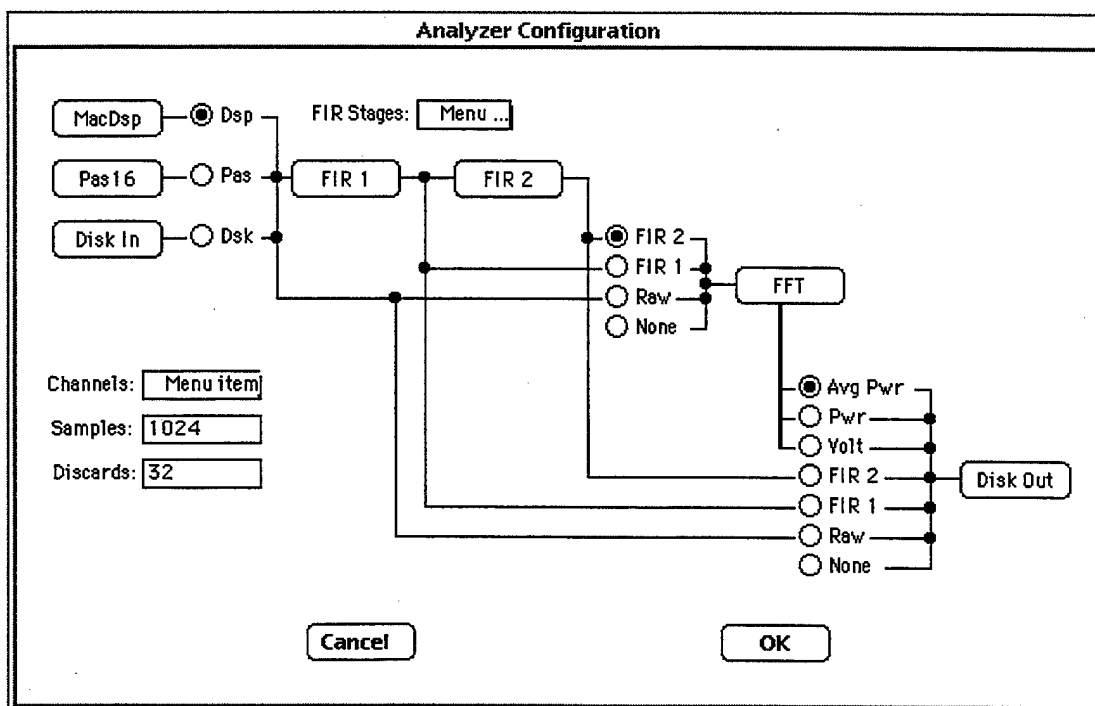

Figure 2. Example of a graphical configuration window used in the upgraded radiometer.

The next step in the upgrade was to add a set of graphical configuration windows to the controller program to augment the scriptable interface described above. An example of

the main analyzer configuration window is shown in Figure 2. The buttons and connecting lines show the flow of data processing from input sampling to the output disk file, and each push-button (rounded-corner rectangle) brings up an additional configuration window for a particular sub-system (sampling rate, FIR or FFT parameters, disk file name, etc.). Thus, the controller program can be conveniently configured interactively as well as through an AppleScript program.

Also during this period of the upgrade, because it was becoming clear that our initial experimental measurements with the upgraded radiometer would be to attempt to detect very weak narrowband signals from the HIPAS and HAARP transmitters in Alaska, emphasis was placed on the narrowband filtering functions provided by the cascaded FIR filters and FFT, and on the display of processed data. The FIR filter coefficients were tuned to produce flatter response in their passband and to increase their passband relative to the sampling frequency. The filtering capabilities (using the Spectral Innovations hardware DSP card and the controller program) were augmented through post-processing using Matlab. An AppleScript program was developed to sample and record data to a disk file and to copy the disk file to tape. Subsequently, another AppleScript program read the tape back and processed it to produce averaged power spectra using the controller program, after which the spectra were displayed and plotted using Matlab. The AppleScript programs read a text file containing the requested data collection times and duration and combined these with the desired center frequency and bandwidth for frequency analysis to create the required Apple Events to communicate between the various component programs.

2.2. The Computer Interface Unit

The computer upgrade has been described above in considerable detail to facilitate operation of the upgraded radiometer. In parallel with the computer upgrade, a hard-wired interface unit was constructed by Mr. P. R. McGill to physically link the Macintosh Quadra computer with the various functions of the Thule radiometer. By the end of September 1996, the upgrade of the radiometer was completed to a stage where experimental measurements could be made. At that time preparations began for the HIPAS and HAARP experimental campaigns that were to be conducted during 1997. We will now describe the experimental part of our study.

3. Experimental Measurements

3.1. Initial Preparations

In the Fall of 1996, in preparation for the HIPAS and HAARP campaigns that were planned for early in 1997, we made the important decision to keep our radiometer upgrade on the Stanford campus instead of installing it at Thule. There were two reasons for this decision: one scientific and one practical.

The scientific reason for our decision was the expected greatly improved strength of the ELF signals produced in the vicinity of Stanford as compared with Thule. We drew this conclusion from the expected coverage figure for HAARP at 100 Hz that appeared in a summary report prepared by a committee that was formed to consider applications and research opportunities using HAARP [*Papadopoulos et al.*, 1995]. The figure placed Thule in a null of the expected coverage pattern, whereas Stanford (and the Western U.S.) was located very nearly in the maximum of the expected coverage pattern. We understood that the figure probably summarized preliminary data, but it was the best information available to us at the time.

The practical reason for our decision was the availability of much greater resources at Stanford for what would be our first experiments with the upgraded radiometer system and, indeed, for what would be some of the first experiments to generate ELF signals by modulating electric currents in the ionosphere with either the HIPAS and HAARP HF transmitters. In contrast, we would have few or no resources at Thule, and the installation of the upgrade would have to be done during winter if it was to be ready in time for the first experiments planned for 1997. We were also fortunate to have a spare radiometer at Stanford, following termination of the measurement program at L'Aquila in Italy [*Meloni et al.*, 1992] and the return of the Italian radiometer to the campus.

As a result of these considerations, during October–December 1996, the radiometer upgrade hardware was moved from our Laboratory in the central campus to a field site in the Stanford foothills (“Site 522”, near the 150-ft radiotelescope), near where ELF and VLF signals are recorded continuously with the Stanford University radiometer. The upgrade computer and associated components were installed in the racks of the L'Aquila system and

connected to the loop antenna preamplifier outputs in parallel with the existing Stanford system. The GPS antenna for the upgraded system was installed on the roof of the building, where it had a clear field-of-view to the GPS satellites. Two 28.8 kbps Motorola modems were purchased and installed at the field site and at a campus office to enable remote control of the system using Timbuktu, a remote screen-sharing and data transfer program supplied by Farallon Communications, Inc. (Although not tried, there is a Windows version of Timbuktu available which should enable cross-platform control.)

It was found that remote control using Timbuktu worked very well, even at 14.4 kbps. Remote editing and program operation was similar to local operation, and spectral displays with Matlab (consisting of about 1000 vectors) were quite feasible. Display of color bit-mapped images, however, was quite slow. The Matlab plots were saved as Postscript files, and the Postscript files were transferred via modem for printing on a local printer. This ability to carry out remote control is of particular significance for future operation of the radiometer during HAARP experiments.

At the time of the fall American Geophysical Union meeting in San Francisco (December 1996), the system was operational and it was demonstrated to Mr. John Rasmussen and Dr. Paul Kossey of Phillips Laboratory during a visit they made to the Stanford campus.

3.2. The 1997 Campaigns

During the period January–March 1997, we participated in two Alaska campaigns involving ionospheric heating by the HIPAS and HAARP transmitters, during which we recorded and analyzed ELF data on the Stanford campus. Although no signals from the HIPAS or HAARP transmitters were detected, we were able to verify the upgraded radiometer's ability to detect very weak signals using the internal calibration test signals provided by the antenna hardware.

The recording system was augmented by purchasing a PowerKey Pro 200 line filter and reset generator. This unit, manufactured by Sophisticated Circuits, Inc., provides a watchdog timer and automatic reboot capability and communicates to the Macintosh through its Apple Desktop Bus (ADB) so it does not occupy any serial port. In addition, a telephone ring detection circuit can be used to force a system reset if desired.

The first campaign started in January 1997 and it involved HF transmissions from HIPAS in an attempt to generate 198 Hz ELF signals for submarine reception in the Gulf of Alaska. Since we were not informed of the start of this experiment until it was already under way, we missed the first few days of transmissions. However, we successfully recorded data during the interval 18–20 January 1997. Unfortunately, we had equipment problems on the very last day of the campaign, which resulted in our last data being taken at 01:14 PST (09:14 UT) on 20 January, a few hours before signals were reported being received at the submarine. A plot of the data in the band 196–200 Hz using an analysis bandwidth of 0.01 Hz is shown in Figure 3. We do not consider the very small peak at 196 Hz to be statistically significant. In this plot, -15 dB corresponds to a level of 10 fT, the level of the noise in the 196–200 Hz band. Signals outside the central filter passband probably are aliases resulting from the down-sampling of the cascaded FIR filters.

The second campaign took place between 28 February and 20 March 1997, and we recorded data whenever the HIPAS or HAARP transmitter was scheduled to be on for several minutes with a CW signal below about 300 Hz. Altogether some 175 runs were recorded, ranging from 5 to 25 minutes duration each. Some were processed at a single frequency while others were processed at several frequencies. However, no detectable signals were seen in any of the processed data. The background noise level varied with a diurnal pattern, but we should have been able to detect signals of about 10 fT or greater. A typical example of the data from 6 March 1997 at 07:00 UT is shown in Figure 4 for a center frequency of 156 Hz. Although there is a strong spike in the passband, it is at the wrong frequency, about 156.8 Hz, and it was seen when the transmitter was off, so it is not related to the Alaska transmissions.

For comparison, a plot of the spectrum of the 160 Hz component of the internal calibration signal at a level of 10 pT is shown in Figure 5. The spectral line corresponding to this calibration signal is precisely centered at 160 Hz, with a very narrow bandwidth (essentially all of its energy is within one frequency bin). The 10 pT level of various calibration signal components was used to establish overall system calibration.

Because of dynamic ionospheric conditions, the transmission schedules were subject to change on a relatively short time scale. Often we did not hear about the final schedule until minutes before the start of a run, and then only if we called the control center in Alaska

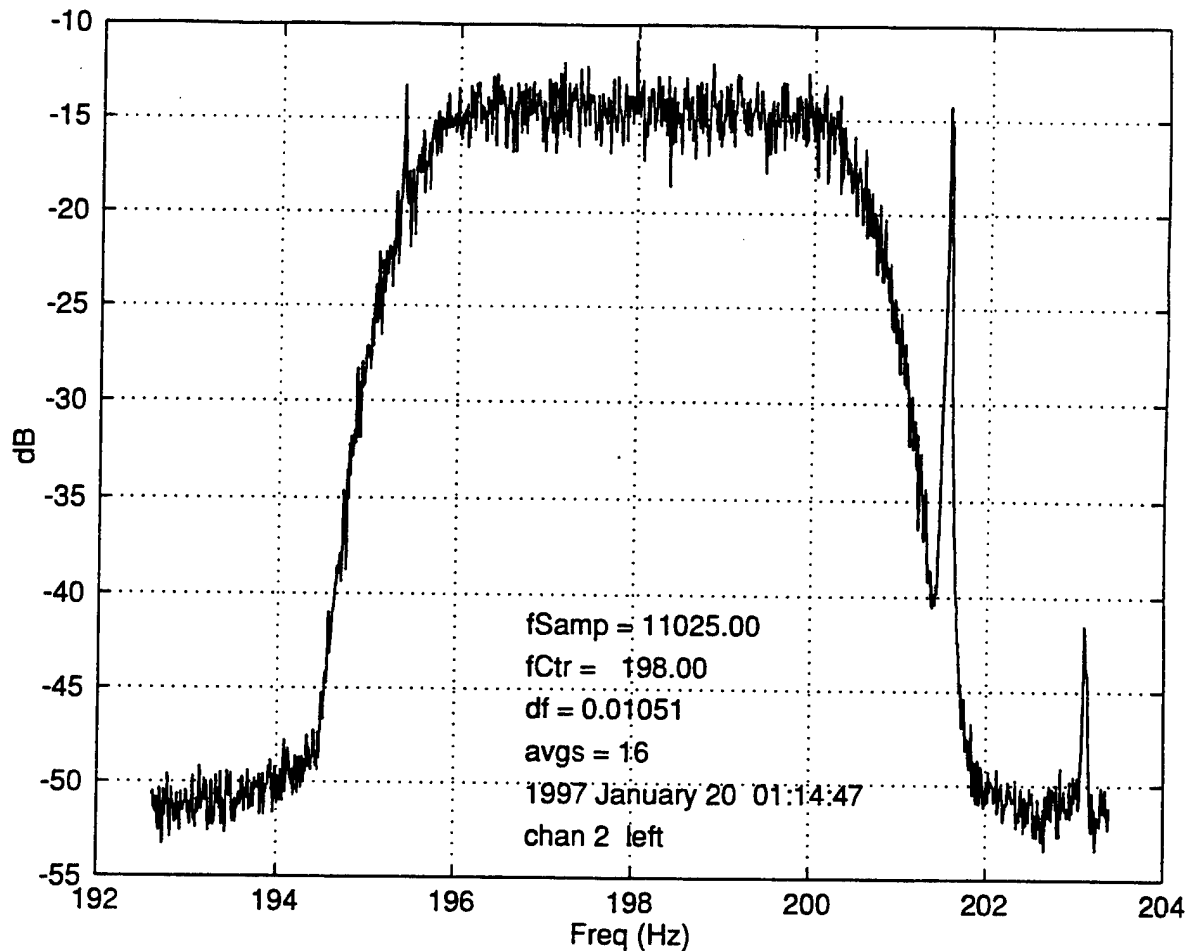

Figure 3. An example of the measurements made on 20 January 1997 at around 01:15 UT – a time when the HIPAS transmitter was attempting to generate ELF signals at a frequency of 198 Hz. The relevant passband for our measurements is roughly 196–200 Hz, the noise/signals outside this band being relatively suppressed. The potentially very strong interfering signal that can be seen outside this passband at a frequency of about 201.5 Hz is probably an alias.

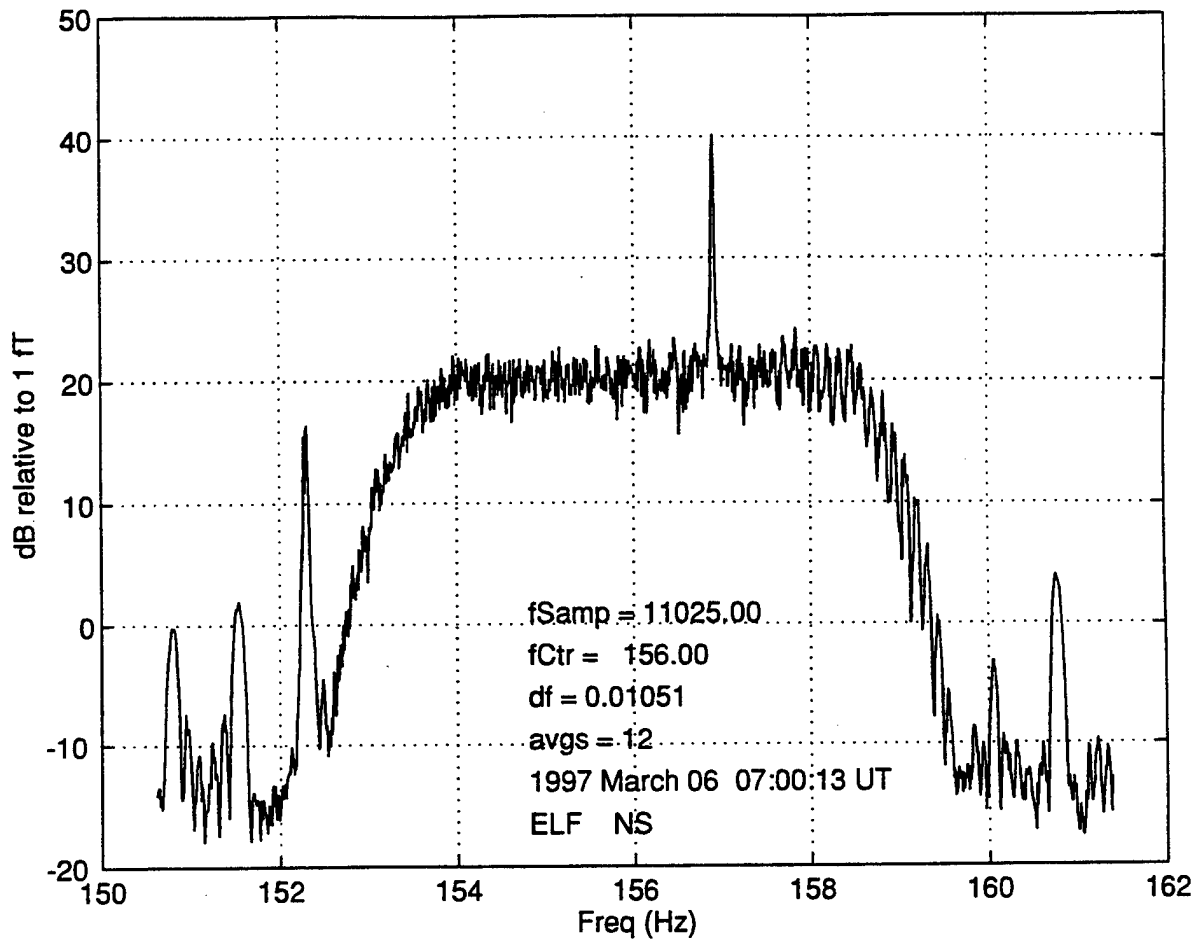

Figure 4. Another example of the ELF measurements made with the upgraded radiometer system. In this case, the measurements were made on 6 March 1997 at around 07:00 UT – a time when the HIPAS transmitter was attempting to generate ELF signals at a frequency of 156 Hz. The relevant passband for our measurements is roughly 154–158 Hz, the noise/signals outside this band being relatively suppressed. There is a signal at 156.8 Hz, but it was also recorded at times when the transmitter was off and thus it does not relate to the Alaska transmissions.

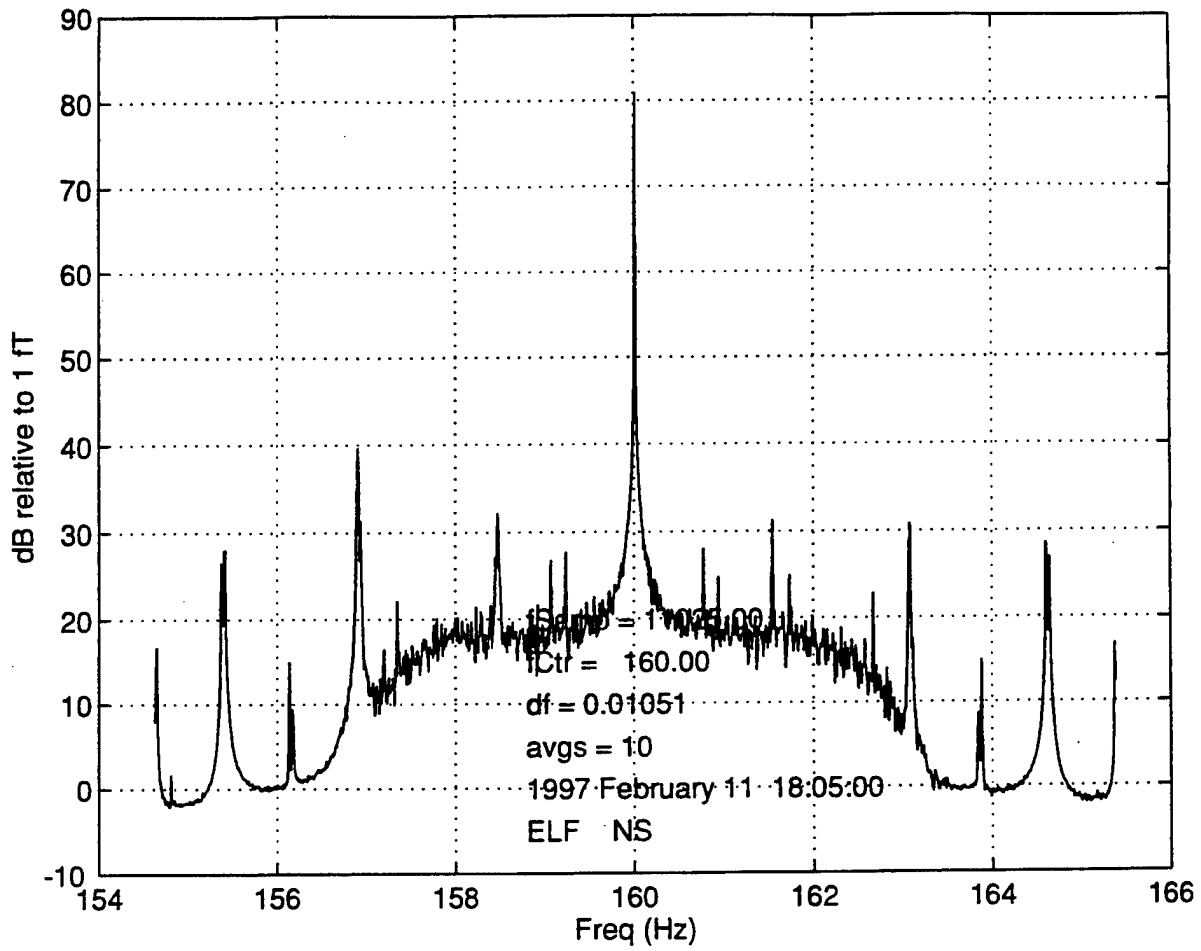

Figure 5. Calibration of the radiometer response in the frequency band 158–162 Hz with a known 10 pT signal at 160 Hz.

from Stanford. In future campaigns, it would be helpful if the schedules could be made available on a more timely basis over the Internet, so that it would not be necessary to rely on telephone conversations with the transmitter operations staff in order to plan our recording schedule.

Later analysis of the data from the two campaigns, using increasingly sophisticated data analysis techniques, failed to reveal any HIPAS or HAARP signals in among the background

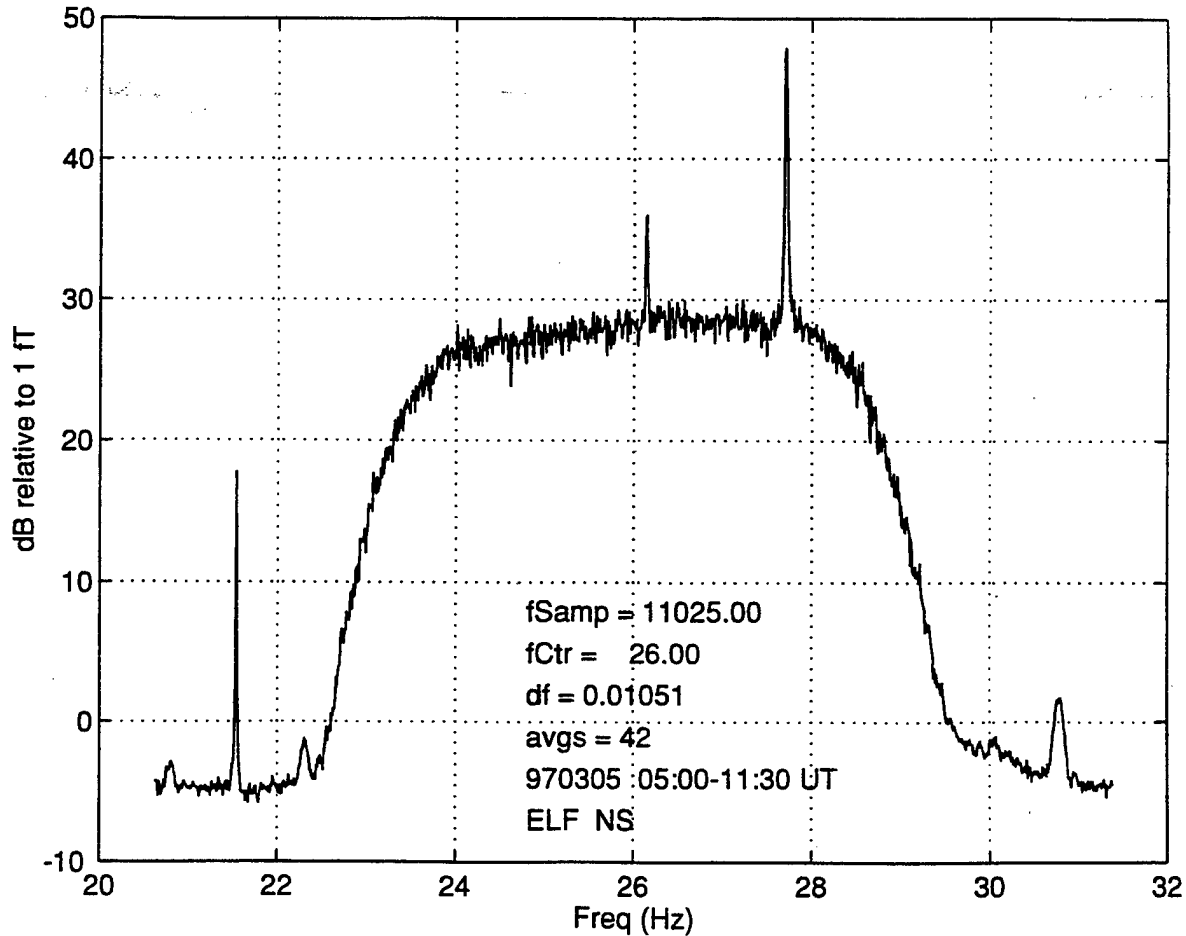

Figure 6. An average of 42 separate spectrums obtained over 5.5 hours on 5 March 1997 during which the HF transmissions from the HIPAS transmitter were being modulated at 26 Hz. The weak signal that can be seen at 26.15 Hz was clearly separate in frequency from any 26.0 Hz signal, and it also occurred at times when HIPAS was not transmitting. The noise level in the measurement passband is about 28 fT

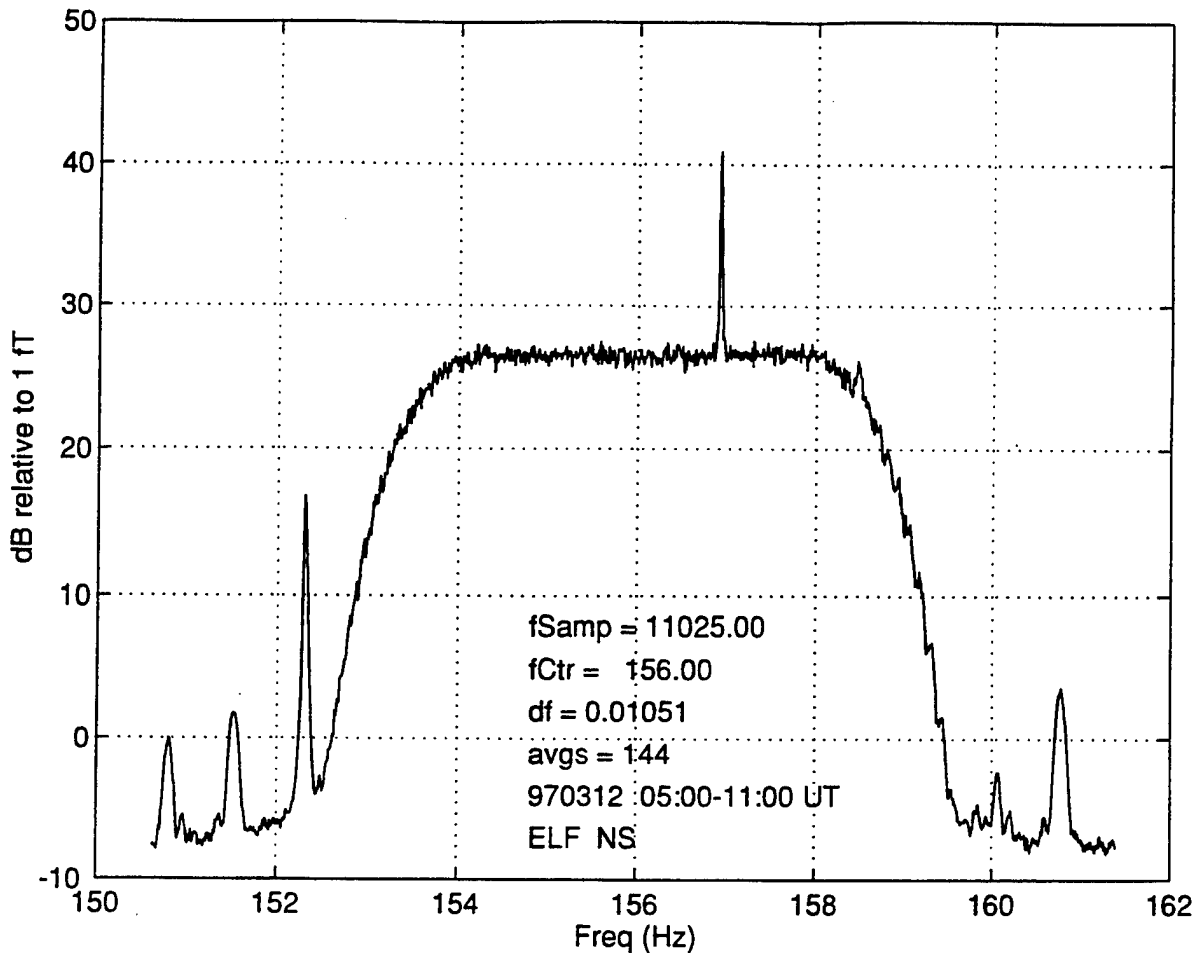

Figure 7. An average of 144 separate spectrums obtained over a 7 hour interval on 12 March 1997 during which the HF transmissions from the HIPAS transmitter were being modulated at 156 Hz. The noise level in the measurement passband is about 22 fT.

noise. To illustrate one of the analysis techniques used, in this case to search for a presumable very weak signal, power spectra from several hours were sometimes incoherently averaged together. An example of such data averaged over 5.5 hours on 5 March (42 separate transforms) is shown in Figure 6. The peak at 26.15 Hz is at the wrong frequency, and was seen when the Alaska transmitters were off, so it does not represent a signal detection. The noise level in the 0.01 Hz passband near 26 Hz was about 28 fT (29 dB above 1 fT). A second example is shown in Figure 7, for a 7-hour interval on 12 March representing 144 individual transforms centered at 156 Hz. The noise level was a little lower, about 22 fT.

4. Conclusion

We have described in detail our upgrade of the computer system for the ELF/VLF radiometer installed at Thule, Greenland. In order for us to participate in the 1997 HIPAS and HAARP campaigns, the upgraded system was not installed in the Thule radiometer, but instead it was installed in a spare radiometer on the Stanford campus and operated in parallel with the radiometer that operates continuously on the campus as part of Stanford's global survey of ELF/VLF radio noise. The upgraded computer system can be installed at Thule whenever it is desired by our sponsors, but we believe it is better to keep it on the Stanford campus and to operate it from there until it (1) the system has been thoroughly tested, and (2) until the future HAARP campaigns have been more formally organized.

Although no ELF signals were detected during the two HIPAS and HAARP campaigns of 1997, our measurements demonstrated the great sensitivity that can be achieved in the ELF range by a combination of recording with an upgraded radiometer and subsequent processing of the recorded data. The data presented in this report are fully calibrated and the measured noise levels in our processed data are such that we should be able to detect ELF man-made signals with amplitudes greater than 10-30 fT, the precise level depending on several factors, including the frequency of the signals and the time of day. The level of solar activity will undoubtedly also be an important factor influencing the detectability of ELF signals generated by HIPAS and HAARP, but our measurements gave us no information about the effects of solar activity (whereas the frequency of the signals to be detected and the time of day clearly affected the noise background for the measurements). Given a strong auroral electrojet in the ionosphere that can be reached by the HAARP HF transmissions, we have little doubt that ELF signals can be produced that will be detectable with our upgraded radiometer in California.

5. References

- C.C.I.R., "World distribution and characteristics of atmospheric radio noise," Report 322, International Radio Consultative Committee, International Telecommunication Union, Geneva, 1964.
- Fraser-Smith, A. C., and R. A. Helliwell, "The Stanford University ELF/VLF Radiometer Project: Measurement of the Global Distribution of ELF/VLF Electromagnetic Noise," *Proc. 1985 IEEE Internat. Symp. on Electromag. Compat.*, IEEE Cat. No. 85CH2116-2, 305-311, August 1985.
- Fraser-Smith, A.C., R.A. Helliwell, B.R. Fortnam, P.R. McGill, and C.C. Teague, "A New Global Survey of ELF/VLF Radio Noise," Conf. on Effects of Electromagnetic Noise and Interference on Performance of Military Radio Communication Systems, Lisbon, Portugal, 26-30 October, 1987 (*AGARD Conf. Proceedings No. 420*, pp. 4A-1 to 4A-9, December 1988. 13(10), 95-98, 1993).
- Fraser-Smith, A. C., and J. P. Turtle, "ELF/VLF Radio Noise Measurements at High Latitudes during Solar Particle Events," paper presented at the 51st AGARD-EPP Specialists' Meeting on "ELF/VLF/LF Radio Propagation and Systems Aspects," Brussels, Belgium, 28 September-2 October, 1992. Published in *AGARD Conf. Proceedings No. 529*, pp. 16-1 to 16-8, May 1993.
- Meloni, A, P. Palangio, and A. C. Fraser-Smith, "Measurements of ELF/VLF radio noise near L'Aquila, Italy," *IEEE Trans. Antennas Propagat.*, 40, 233-236, 1992.
- Papadopoulos, D., Bernhardt, P. A., Carlson, Jr., H. C., Gordon, W. E., Gurevich, A. V., Kelley, M. C., Keskinien, M. J., Sagdeev, R. Z., and Milikh, G. M., *HAARP, Research and Applications*, Summary Report, p. 11, Univ. of Maryland, East-West Space Science Center, Dept. of Physics, College Park, MD 20742, June 1995.