

This evaluation of the Electrohome 9501LC CRT projection system is intended to quantify the performance of the projector as it is used in combination with a Stewart Studiotek 130 projection screen for demonstrating progressively scanned images of 1280 pixels x 1024 lines and 2000 pixels x 1340 lines.

EVALUATION of the Electrohome 9501LC CRT Projector

**National Information Display Laboratory
at the
Sarnoff Corporation
CN 5300, Princeton, NJ 08543-5300**

NIDL Publication No. 021298-063

June 19, 1998

Approved for public release; distribution is unlimited.

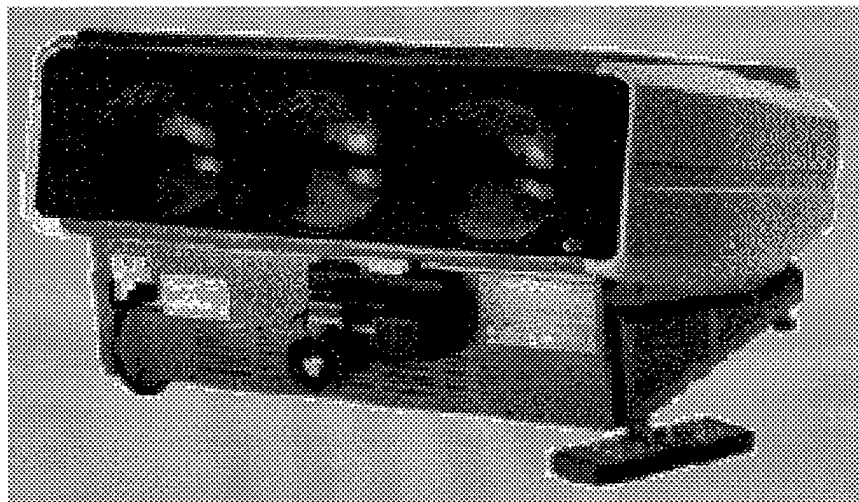

19990324 001

NOTICE:

This report was prepared on behalf of the National Information Display Laboratory (NIDL) by the Sarnoff Corporation (SARNOFF) as an account of work sponsored by the United States Government. The United States Government, the NIDL and SARNOFF, and any person acting on their behalf:

A. Makes no warranty or representation, expressed or implied, with respect to the use of any information contained in this report, or that the use of any information, apparatus, method, or process disclosed in this report is free from infringement of any third party rights; or

B. Makes no endorsement of any of the products reported on herein; or
C. Assumes no liabilities with respect to the use of, or for damages resulting from the use of, any information, apparatus, method, or process disclosed in this report.

CONTENTS

| | |
|---|-----------|
| Foreword | ii |
| ANSI Complete Sample Specification | iii |
| NIDL Evaluation Datasheet | iv |
| Performance Summary | v |
| Summary Comments on NIDL Evaluation Datasheet | vi |
| | |
| Section I Introduction | 1 |
| A. The Electrohome 9501LC Projection Display | 2 |
| B. Initial Display Setup..... | 2 |
| | |
| Section II Colorimetric Measurements | 3 |
| A. Illuminance, Luminance and Chromaticity Uniformity | 5 |
| B. Luminance Stability vs. Fill Factor..... | 10 |
| C. Contrast Modulation | 11 |
| D. Contrast Ratio | 14 |
| E. System Gamma | 16 |
| F. Halation..... | 18 |
| | |
| Section III Analysis and Conclusions..... | 19 |
| | |
| Appendix A Glossary of Terms..... | 21 |

FOREWORD

On behalf of the government user community, the *National Information Display Laboratory* (NIDL) has prepared this report, which discusses the performance of the following projection display:

Electrohome 9501LC Projector and Stewart Studiotek 130 Screen

as one in a series of evaluations of projection displays. Such objective evaluations are essential to enable government users to obtain, at reasonable cost, projection displays with the required performance. The following summary pages give the reader an overview of the results.

A document that describes how the ANSI measurements are made, is available from the American National Standards Institute:

- NAPM IT7227-1996 Draft 5, Revision and Redesignation of ANSI Standard No. IT7.215-1992, *For Audiovisual Systems - Data Projection Equipment and Large Screen Data Displays - Test Methods and Performance Characteristics*. American National Standards Institute, 11 West 42nd Street, New York, New York 10036.

Two companion documents that describe other measurement procedures are available directly from the NIDL and may also be accessed on the world wide web at <http://www.nta.org/SoftcopyQualityControl/MonitorReports>:

- NIDL Publication No. 171795-036, *Display Monitor Measurement Methods under Discussion by EIA (Electronic Industries Association) Committee JT-20, Part 1: Monochrome CRT Monitor Performance, Draft Version 2.0, July 12, 1995*.
- NIDL Publication No. 171795-037, *Display Monitor Measurement Methods under Discussion by EIA (Electronic Industries Association) Committee JT-20, Part 2: Color CRT Monitor Performance, Draft Version 2.0, July 12, 1995*.

The NIDL procedures were developed in collaboration with the display industry and have been distributed for comments to EIA, ANSI, ASTM, ISO, and VESA Committees and have been exercised by the National Institute of Standards and Technology.

Other procedures are found in a draft standard being developed at the Video Electronics Standards Association:

- VESA FPD136 Draft #7 Flat Panel Display measurements Standard (Proposal) Version 1.0P, Revision 0.0, November 10, 1997.

Comments, suggestions and questions about this report or the procedures used are welcome and encouraged. Depending on the user's specific application and budget, NIDL would be glad to make a display system recommendation. The NIDL can be reached at:

National Information Display Laboratory,
P. O. Box 8619, Princeton, NJ 08543-8619,
Tel: (609) 951-0150, Fax: (609) 734-2313, e-mail: nidl@nidl.org

ANSI COMPLETE SAMPLE SPECIFICATION

According to NAPM IT7227-1996 Draft 5
Revision and Redesignation of ANSI IT7.215-1992

Electrohome 9501LC

| Brand Model Specification based on measurements of | Electrohome 9501LC July 1997 | |
|--|--|--|
| | Measured | Advertised |
| Light output Lens ANSI Lumens | 198 (2000 x 1340 format) | 1.5:1 260 |
| Correlated color temperature | 8979 K (2000 x 1340 format) 8495 K (1280 x 1024 format) | |
| Aspect ratio | 3H:2V (2000 x 1340 format) 4H:3V (1280 x 1024 format) | |
| Light output uniformity, Brightest zone Dimmest zone | (2000 x 1340 format) 21.5% greater than average 24.1% less than average | |
| Contrast ratio (4 x 4 Chessboard) | 98 to 1 (2000 x 1340 format) 147 to 1 (1280 x 1024 format) | |
| Blanking time Horizontal Vertical | 2.54 μ S 452 μ S | 2 μ S to 6.5 μ S < 300 μ S |
| Resolution at light output (screen center) | 1200 horizontal at 82.914 KHz by 890 vertical at 90.517 Hz | 1500 x 1200 |
| Frequency response at CRT cathode | Not measured | 120 MHz |
| Response time (10% - 90%) | Not measured | |
| Input signal compatibility | | RGB analog, BNC 75 ohms termination Composite video RS-232 for computer control VGA 15 pin HD |
| Color chromaticity White Red Green Blue | $u' = 0.181$ $v' = 0.454$ $u' = 0.434$ $v' = 0.532$ $u' = 0.124$ $v' = 0.564$ $u' = 0.169$ $v' = 0.161$ | |
| Color uniformity White relative to average screen | ? $u' = 0.003$? $v' = 0.013$? $u'v' = 0.013$ | |
| Audio Power Total harmonic distortion | Not measured Not measured | |
| Light source | 9 -inch CRT, electromagnetic focus | |
| Power (Input) Input voltage tolerance | Not measured Not measured | 650 Watts 90VAC to 264 VAC |

NIDL EVALUATION DATASHEET
Electrohome 9501LC
and
Stewart Studiotek 130 Screen

I. MANUFACTURER'S DATA

| | | |
|--------------------------------------|--|--|
| Projector Manufacturer and Model | Electrohome 9501LC Serial No. 092290004 | |
| Price | \$45,000 | |
| Monochrome or Color | Color | |
| Screen Manufacturer and Model | Stewart Studiotek 130 | |
| Screen Gain | 1.3 | |
| Addressable Pixel Number | 1280 x 1024 | 2000 x 1340 |
| Screen Diagonal (viewable) | 78.4 inches | 88.0 inches |
| Horizontal Scan Rate | 65 KHz | 82.9 KHz |
| Vertical Scan Rate | 60 Hz, progressive | 60 Hz, progressive |
| Viewing position, distance and angle | 120 inches, ±12° Vert., ±14° Horiz. | 120 inches, ±12° Vert., ±17° Horiz. |
| Image Size (H x V) viewable | 61.25 x 49 inches | 73.13 x 49 inches |
| Pixel Size | 47.9 x 47.9 mils | 36.6 x 36.6 mils |

II. MEASURED PERFORMANCES**A. Performance Related to Illuminance of the Projector Only**

| | | |
|--------------------------------|---------------------|---------------------|
| Light Output (9-point average) | 208 lumens | 190 lumens |
| Illuminance Nonuniformity | 19% (99 to 121 Lux) | 34% (69 to 104 Lux) |

B. Performance Related to Luminance of the Image on the Screen

| | | |
|--|----------------------|----------------------|
| Warmup Time | Not measured | Not measured |
| Full-Screen Center Minimum Luminance | 9.23 mFL | 4.45mFL |
| Full-Screen Center Maximum Luminance | 13.8 fL | 11.55 fL |
| Halation | 3.13 % | Not measured |
| Contrast Ratio with halation (darkroom) | 32:1 | 33:1 |
| Luminance Nonuniformity | 53% (6.5 to 13.9 fL) | 57% (4.9 to 11.6 fL) |
| Luminance Chessboard Contrast Ratio | 147 : 1 | 98: 1 |
| CIE 1936 Color Coordinates of white | x = 0.284, y = 0.318 | x = 0.280, y = 0.312 |
| Color Uniformity of full screen white | 0.020 ? u'v' units | 0.015 ? u'v' units |
| Color Grayscale Tracking between 1% Lmax to 100% Lmax | 0.020 ? u'v' units | Not measured |
| System Gamma | 2.04 | Not measured |
| Luminance Stability, 11% to 100% full screen duty factor | 51% | Not measured |

C. Performance Related to Resolution of the Image on the Screen

| NIDL pixels @ 50% Lmax | H-pixels | V-pixels | H-pixels | V-pixels | |
|---------------------------|------------|----------|----------|----------|-----|
| Text Threshold Cm=50%: | Center | 834 | 615 | 843 | 524 |
| | Periphery | 618 | 563 | 680 | 447 |
| | Screen avg | 642 | 569 | 698 | 456 |
| Imagery Threshold Cm=25%: | Center | 1182 | 946 | 1436 | 823 |
| | Periphery | 1014 | 913 | 992 | 654 |
| | Screen avg | 1033 | 916 | 1041 | 673 |

* Based on the CIE 1976 UCS Chromaticity Diagram: $u' = 2x/(6y-x+1.5)$, $v' = 4.5y/(6y-x+1.5)$

Use or disclosure of data on this sheet is subject to the restrictions on the cover and title of this report.

Electrohome 9501LC**– PERFORMANCE SUMMARY –**

The projector excluding the screen produces light output (illuminance) of 198 ANSI lumens at 1200 x 890 ANSI pixel resolution.

Important performance characteristics of a projection display are resolution and light output. This projector and screen combination, as tested, exhibit the ability to display 72% of the number of pixels being addressed at 1280 x 1024, and 26% of the number of pixels being addressed at 2000 x 1340. A contrast modulation (C_m) of 25% or more is clearly perceivable and appropriate for the display of imagery. A contrast modulation of 50% or more is appropriate for the display of small-size alphanumeric information. Based on contrast modulation measurements for 1-pixel-on/1-pixel-off, 2-on/2-off, and 3-on/3-off patterns displayed at 50% L_{max} , the average number of resolvable pixels over the entire screen are determined by linear interpolation to be:

2000 x 1340 Addressability

- 1041 x 673 @ $C_m = 25\%$
- 698 x 456 @ $C_m = 50\%$

1280 x 1024 Addressability

- 1033 x 916 @ $C_m = 25\%$
- 642 x 569 @ $C_m = 50\%$

SUMMARY COMMENTS ON MEASUREMENTS PERFORMED

1. **Illuminance, Luminance and Chromaticity Uniformity:** The illuminance* measured directly into the projector varies by up to 34% across the image. The full white screen luminance** measured on the projection screen (screen gain = 1.3) varies by up to 57% center to edge. Chromaticity variations $\Delta u'v'$ across the white full screen were as great as 0.020 units (0.004 is visible) for a horizontal viewing angle of $\pm 14^\circ$.

2. **Luminance Stability vs. Fill Factor:** A 51% drop in luminance was measured on the screen when the video fill factor (average picture level) was increased from 11% to 100% full screen size.

3. **Contrast Modulation:** For the 2000 x 1340 format, the average contrast modulation for 3-on/3-off white grille patterns at 50% Lmax was 53% x 51% (Horizontal x Vertical) for nine sampled screen locations. Contrast modulation for 2-on/2-off grille patterns averaged 23% x 22% (HxV) and averaged 8% x 6% (HxV) for 1-on/1-off grille patterns.

For the 1280 x 1024 format, the average contrast modulation for 3-on/3-off white grille patterns at 50% Lmax was 75% x 74% (HxV) over the screen. Contrast modulation for 2-on/2-off grille patterns averaged 49% x 53% (HxV) and averaged 10% x 18% (HxV) for 1-on/1-off grille patterns.

4. **Resolvable pixels:** Based upon the average contrast modulations determined at nine screen locations for 1-on/1-off, 2-on/2-off, and 3-on/3-off grille patterns at 50% Lmax, the number of resolvable pixels is linearly interpolated for C_m values of 25% and 50% to be:

| <u>2000 x 1340 Addressability</u> | <u>1280 x 1024 Addressability</u> |
|-----------------------------------|-----------------------------------|
| • 1041 x 673 @ $C_m = 25\%$ | • 1033 x 916 @ $C_m = 25\%$ |
| • 698 x 456 @ $C_m = 50\%$ | • 642 x 569 @ $C_m = 50\%$ |

5. **Contrast ratio:** Full screen contrast ratio under dark room conditions measured at screen center is 33:1, including halation effects. Based upon the average luminance (in fL) of white and average luminance of dark rectangular targets simultaneously projected in a 4 x 4 chessboard configuration (ANSI IT7.215 test pattern A.3) at 100% Lmax, the display contrast ratio reflected by the projection screen, is 147:1 for the 1280 x 1024 format, and dropped to 98:1 for the 2000 x 1340 format.

6. **System Gamma:** The value found for gamma is 2.04 for white. The whitepoint chromaticity shifted by up to 0.020 $\Delta u'v'$ units when luminance is decreased to 0.14 fL (1% Lmax). A change of 0.004 $\Delta u'v'$ units is visible.

7. **Halation:** Halation was only 3.13% on a small black patch surrounded by a white background.

Notes:

* Illuminance (lux) refers to luminous flux from the projector. 1 lux = 1 lumen/square meter = 0.0929 footcandle.

** Luminance (fL) is a quantification of the brightness of a surface, in this case, luminous flux per unit solid angle per unit area emitted in a given direction from the surface of the front projection screen. 1 fL = 3.4263 candela per square meter (cd/m^2), 1 $cd/m^2 = 1$ lumen per steradian per square meter.

Example: A projector illuminance of 300 lux (27.9 footcandle) will lead to a screen luminance of 27.9 fL (95.6 candela per square meter), assuming the screen scatters light uniformly in all directions and does not absorb any light, i.e., screen gain = 1.

Use or disclosure of data on this sheet is subject to the restrictions on the cover and title of this report.

Section I

INTRODUCTION

The present study evaluates a production unit of the *Electrohome 9501LC* high-resolution color CRT projector and *Stewart Studiotek 130* projection screen. Only photometric measurements were performed on this system. The primary emphasis of the measurements is the determination of the contrast modulation of the display for on/off grille patterns. In turn, the contrast modulation measurements provide an estimate of the number of resolvable pixels that are displayed on the projection screen. The number of *resolvable* pixels is typically less than the addressability of the display, which is the number of positions that are electronically *addressed*.

We provide below a description of the display that was evaluated and the details of the setup procedures used to prepare the display for measurement. Section II presents the data and results of the photometric measurements. Section III completes the report with analyses of the measurements and final conclusions.

The procedures and calibrations used in the measurements are detailed in the following ANSI standard:

NAPM IT7227-1996 Draft 5, Revision and Redesignation of ANSI Standard IT7.215-1992, *For Audiovisual Systems - Data Projection Equipment and Large Screen*

Data Displays - Test Methods and Performance Characteristics. American National Standards Institute, 11 West 42nd Street, New York, New York 10036.

Other procedures used are found in NIDL documents:

NIDL Publication No. 171795-036, *Display Monitor Measurement Methods under discussion by EIA (Electronic Industries Association) Committee JT-20, Part 1: Monochrome CRT Monitor Performance, Draft Version 2.0*, July 12, 1995.

and

NIDL Publication No. 171795-037, *Display Monitor Measurement Methods under discussion by EIA (Electronic Industries Association) Committee JT-20, Part 2: Color CRT Monitor Performance, Draft Version 2.0*, July 12, 1995.

Other procedures are found in a draft standard currently being developed at the Video Electronics Standards Association:

VESA FPDM136 Draft #7 *Flat Panel Display measurements Standard (Proposal) Version 1.0P, Revision 0.0*, November 10, 1997.

A. The Electrohome 9501LC

The projection system was set up with the following photometric and electrical parameters to display images:

1. Set-up parameters for 2000 x 1340 Addressable Pixels

Photometric Parameters:

- Display format is addressable pixels.
- Raster size is 73.13 x 49 inches
- Addressable pixel size is 36.6 x 36.6 mils.
- Full screen luminance of white is 11.6 fL at screen center.
- Full screen luminance of black is 4.45 mfL at screen center.

Electrical Parameters:

- Line rate is 82.917 kHz.
- Frame rate is 59.998 Hz, progressive (non-interlaced).
- Video data rate is 209.117 MHz
- Pixel time is 4.782 nsec.

2. Set-up parameters for 1280 x 1024 Addressable Pixels

Photometric Parameters:

- Display format is addressable pixels.
- Raster size is 61.25 x 49 inches
- Addressable pixel size is 47.9 x 47.9 mils.
- Full screen luminance of white is 13.8 fL at screen center.
- Full screen luminance of black is 9.23 mfL at screen center.

Electrical Parameters:

- Line rate is 65.000 kHz.
- Frame rate is 60.018 Hz, progressive (non-interlaced) .
- Video data rate is 97.890 MHz.
- Pixel time is 10.215 nsec.

B. INITIAL DISPLAY SETUP

The display was set up in NIDL's display measurement facility using numerous controls accessible to the user on the menu driven remote control provided with the projector. A representative of Electrohome performed the setup procedure and certified that the adjustments were in accordance with their specifications. *Brightness* and *Contrast* controls were adjusted to achieve visually distinguishable steps at both low and high luminance levels of the SMPTE RP-133 gray-scale test pattern. The Electrohome representative also used the remote control unit to adjust *Zone Dynamic Convergence*, *Zone Dynamic Luminance and Color*, *Linearity*, *Size*, *Trapezoid*, *Pincushion*. and *Zone Dynamic Focus*.

With the screen commanded to black (zero count level), the background raster, L_{min} , of the 2000 x 1340 format was measured to be 5 mfL. Then, with the screen commanded to full white (255 count level), the maximum luminance, L_{max} , was measured to be 11.6 fL at screen center. Full correction of luminance uniformity was not possible within the limited range of the available dynamic zone correction.

All photometric measurements are taken from the a single viewing direction as depicted in Fig. II-1 instead of from infinity. Spatial resolution measurements were taken directly into the projector lens for the ANSI pixel measurements.

Section II

COLORIMETRIC MEASUREMENTS

*Reference: Color CRT Monitor Performance, Draft Version 2.0 Section 3.0, page 9.
ANSI Standard No. NAPM IT7.227-1996 and IT.215-1992.*

Instruments used in these measurements included:

- Photo Research SpectraScan PR-704 spectroradiometer, 0.5° aperture
- Photo Research Pritchard-1980A-CD photometer, 1° aperture
- Microvision Superspot 100 Display Characterization System with OM-5 optic module (linear CCD array with photopic filter) imaging through a Canon TV Zoom lens, No. 11307, 1:2.8, V10 x 15, 150mm aperture (variable 15 - 150mm), $f = 5.6$ (variable), focal length 12 ft.
- Graseby Optronics S370 Optometer with Model 268P illuminance sensor.
- Quantum Data 8701 test pattern generator, 400 MHz pixel-rate

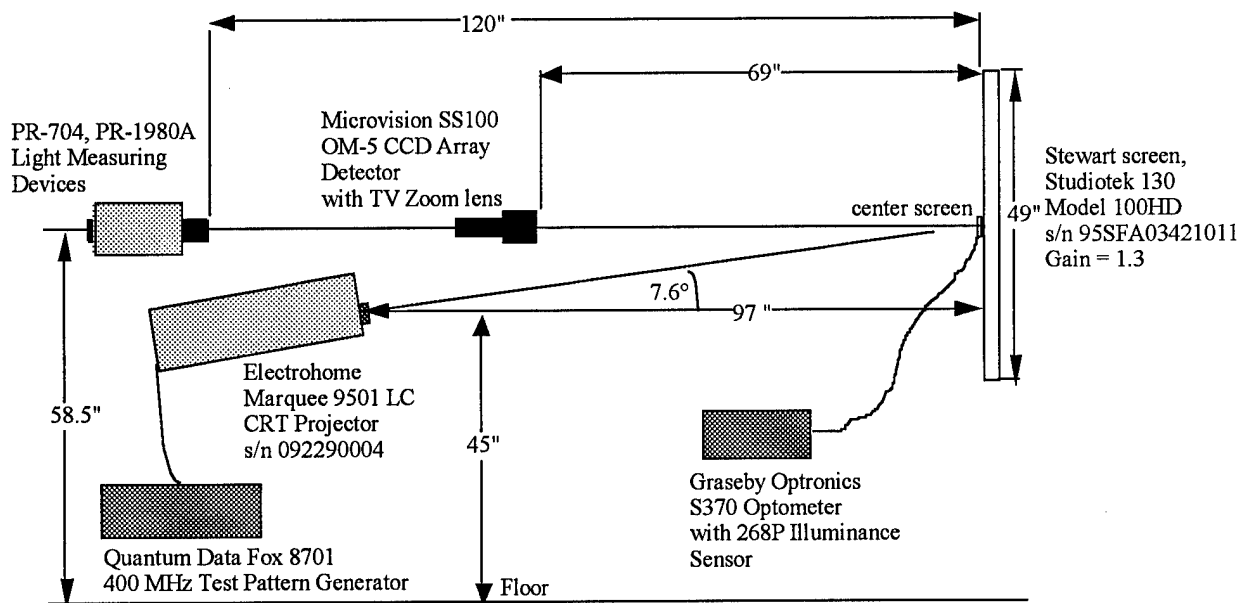

Fig. II-1. Test set up.

This page intentionally left without content.

A. LUMINANCE, ILLUMINANCE AND COLOR UNIFORMITY

Reference: *Color CRT Monitor Performance, Version 1.0 Section 5.3, page 18.*

The illuminance varies by up to 34% across the screen. The full screen luminance varies by up to 57% across the screen at the highest luminance setting. Chromaticity variations, $\Delta u'v'$ across a white full screen exceeded 0.020 units (0.004 is visible).

Illuminance measured according to the ANSI procedure yielded a 9-point average of 198 ANSI lumens with a variation of 21.5% greater than average, and 24.1% less than average for the thirteen ANSI screen locations shown in Figure II.A-1.

Illuminance, luminance and chromaticity coordinate measurements were taken at nine screen positions shown in Figure II.A-2 for the maximum luminance for a full white field and at five screen positions for the Quantum Data "Brightness" test pattern. The data for 2000 x 1340 are shown in Table II.A-1 and in the Figures II.A-3 through II.A-5. The data for 1280 x 1024 are shown in Table II.A-2 and in the Figures II.A-6 through II.A-8.

For both test patterns, the center position showed the highest illuminance. The center to edge variation in screen illuminance was not found to be dependent on the test pattern. For both the full white screen test pattern and the "Brightness" test pattern, the maximum variation in illuminance was found to be 34%.

From a single viewing point, the entire screen is contained within $\pm 12^\circ$ vertically and $\pm 17^\circ$ horizontally. The variation in full white illuminated projection screen with gain of 1.3 (specified by the manufacturer) was found to be as much as 57%.

With the "Brightness" test pattern displayed at the highest luminance level measured, the largest departures from the chromaticity of the center occurred at the 10 o'clock (top

left) corner position and exceeded 0.030 $\Delta u'v'$ units. The results are shown in Fig. II.A-8 in terms of the chromaticity error.

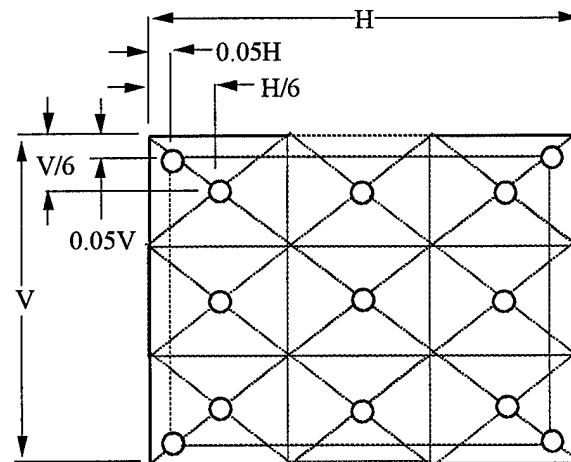

Fig. II.A-1 ANSI screen locations for measurement of light output in ANSI lumens.

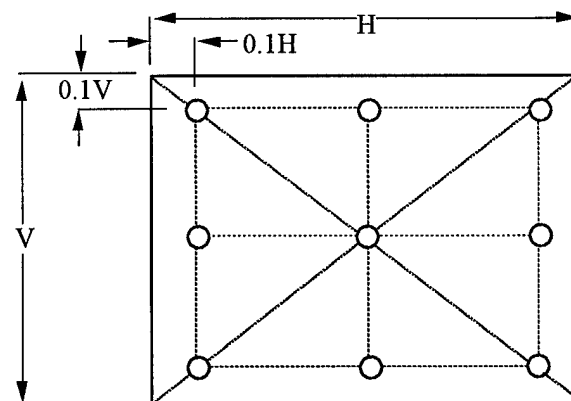

Fig. II.A-2 Nine screen locations specified in ISO, IEC, ANSI-HFES, EIAJ, and VESA standards for measurement of spatial uniformity of illuminance, luminance and chromaticity.

Table II.A-1. Spatial Uniformity of Luminance and Color for 2000 x 1340 Format
 Illuminance (in Lux) and luminance (in fL) taken at five and nine screen positions for 100% Lmax.

Full Screen

| Illuminance (in Lux) for white | | | Luminance (in fL) of white | | |
|--------------------------------|-------|------|----------------------------|-------|-------|
| 72.7 | 89.9 | 68.8 | 5.176 | 7.549 | 4.934 |
| 83.8 | 103.9 | 78.9 | 6.872 | 11.55 | 6.201 |
| 73.9 | 96.5 | 71.7 | 5.997 | 9.867 | 5.397 |

| Illuminance (in Lux) for black | | | Luminance (in fL) of black | | |
|--------------------------------|--------|--------|----------------------------|------|------|
| 0.0169 | 0.0229 | 0.0212 | 1.70 | 2.49 | 1.84 |
| 0.0233 | 0.0344 | 0.0241 | 2.22 | 4.45 | 2.81 |
| 0.0228 | 0.0226 | 0.0308 | 2.28 | 3.49 | 2.45 |

Illuminance* of Projector for full white

| | |
|--------------------|--------------------|
| min | 68.8 lux |
| max | 103.9 lux |
| uniformity | 34 % |
| Avg. screen | 82 lux |
| Screen area | 2.31 square meters |
| Avg. Luminous flux | 190 lumens |
| ANSI Lumens | 198 +21.5%,-24.1% |

Luminance of Screen for full white**

| | |
|---------------|----------------------------------|
| min | 4.9 fL |
| max | 11.6 fL |
| uniformity | 57 % |
| Avg screen | 7.1 fL |
| Screen gain | 1.3 |
| Viewing angle | ±12° vertical ±17° horizontal |

Notes:

* Illuminance (lux) refers to the amount of light falling upon a surface, in this case, luminous flux from the projector incident on the surface per unit area of the front projection screen. 1 lux = 1 lumen/square meter = 0.0929 footcandle.

** Luminance (fL) is a quantification of the brightness of a surface, in this case, luminous flux per unit solid angle per unit area emitted in a given direction from the surface of the front projection screen. 1 fL = 3.4263 candela per square meter (cd/m²), 1 cd/m² = 1 lumen per steradian per square meter.

Example: A projector illuminance of 300 lux (27.9 footcandle) will lead to a screen luminance of 27.9 fL (95.6 candela per square meter), assuming the screen scatters light uniformly in all directions and does not absorb any light.

Electrohome 9501LC projector and Stewart Studiotek 130 projection screen

2000 x 1340

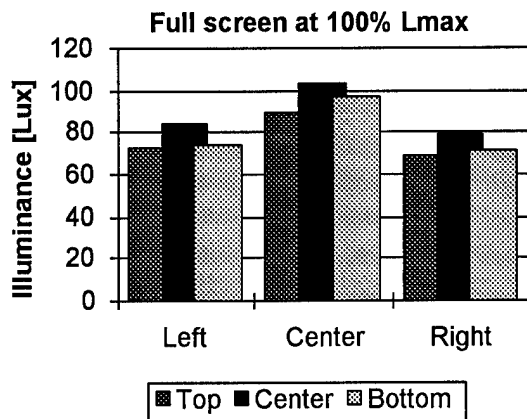

Fig. II.A-3 Spatial Uniformity of Illuminance.

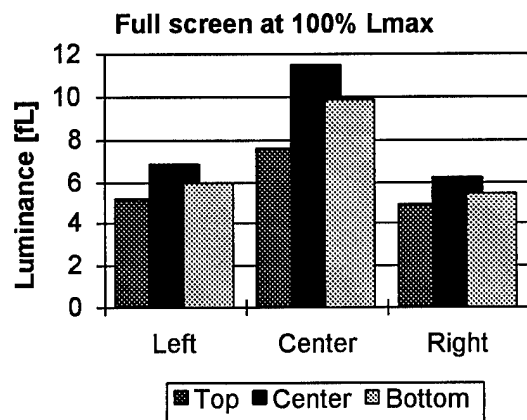

Fig. II.A-4 Spatial Uniformity of Luminance

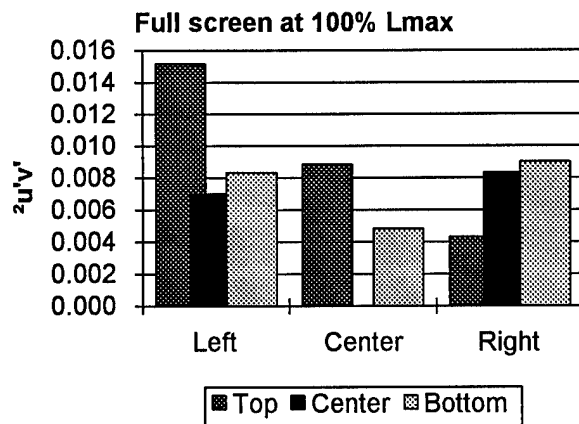

Fig. II.A-5 Spatial Uniformity of Color (vs. Center)
A chromaticity error, $u'v'$, of 0.004 is visible.

Table II.A-2. Spatial Uniformity of Luminance and Color for 1280 x 1024 Format
 Illuminance (in Lux) and luminance (in fL) taken at five and nine screen positions for 100% Lmax.

FOX "Brightness" test pattern

| Illuminance of projector (in Lux) | | | Luminance from screen (in fL) | | |
|-----------------------------------|-----|-----|-------------------------------|-------|-------|
| 164 | | 158 | 12.32 | | 13.25 |
| | 251 | | | 28.04 | |
| 168 | | 157 | 14.24 | | 12.96 |

Full Screen

| Ewhite (in Lux) | | | Lwhite (in fL) | | |
|-----------------|-------|-------|----------------|------|------|
| 99.7 | 108.2 | 98.6 | 6.48 | 8.73 | 6.81 |
| 106.7 | 121.1 | 113.1 | 9.76 | 13.8 | 8.87 |
| 103.6 | 111 | 103.4 | 8.48 | 11.4 | 7.48 |

| Eblack (in Lux) | | | Lblack (in mfl) | | |
|-----------------|--------|--------|-----------------|------|------|
| 0.0501 | 0.0574 | 0.0574 | 4.09 | 5.73 | 3.77 |
| 0.0622 | 0.0722 | 0.0702 | 5.71 | 9.23 | 5.12 |
| 0.0542 | 0.0651 | 0.0634 | 4.93 | 6.43 | 4.28 |

Illuminance of Projector for full white

| | |
|---------------|--------------------|
| min | 98.6 lux |
| max | 121.1 lux |
| uniformity | 19 % |
| Avg screen | 107 lux |
| Screen area | 1.94 square meters |
| Luminous flux | 208 lumens |

Luminance of Screen for full white

| | |
|---------------|----------------------------------|
| min | 6.5 fL |
| max | 13.9 fL |
| uniformity | 53 % |
| Avg screen | 9.1 fL |
| Screen gain | 1.3 |
| Viewing angle | ±12° vertical ±14° horizontal |

Electrohome 9501LC projector and Stewart Studiotek 130 projection screen

1280 x 1024

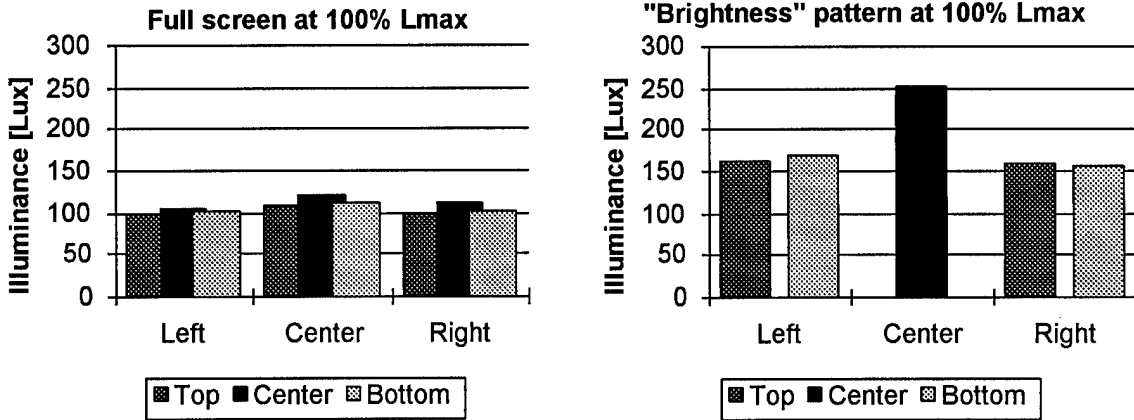

Fig. II.A-6 Spatial Uniformity of Illuminance.

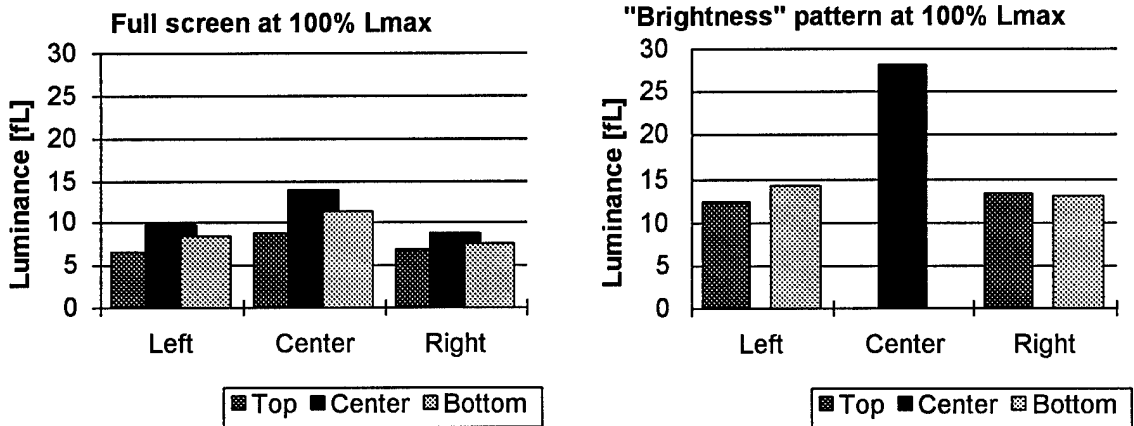

Fig. II.A-7 Spatial Uniformity of Luminance

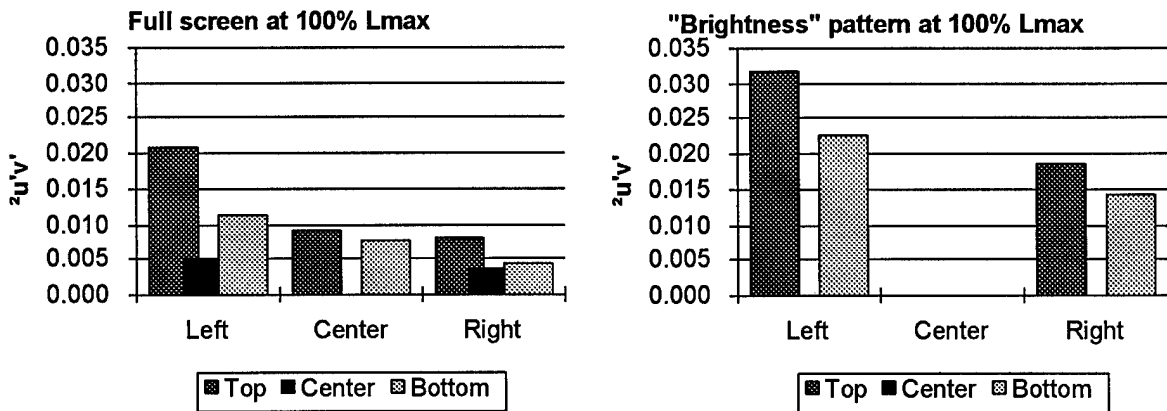

Fig. II.A-8 Spatial Uniformity of Color (vs. Center).
A chromaticity error, $\Delta u'v'$, of 0.004 is visible.

B. LUMINANCE STABILITY VS. FILL FACTOR

Reference: Color CRT Monitor Performance, Draft Version 2.0 Section 4.3, page 11.

There is a 51% decrease in luminance with increasing fill factor from 11% to full screen.

Center screen luminance was measured for white patches on a black background (Quantum Data "Brightness" test pattern) and for the full screen. The change in center screen luminance with decreasing fill factor (decreasing percentage of screen that is

white) is quite significant. Luminance more than doubles from 13.8 fL to 28 fL when video fill factor, or average picture level, is decreased from full screen to 11% of full screen as shown in Fig. II.B-1, below.

73" x 49" active projected image

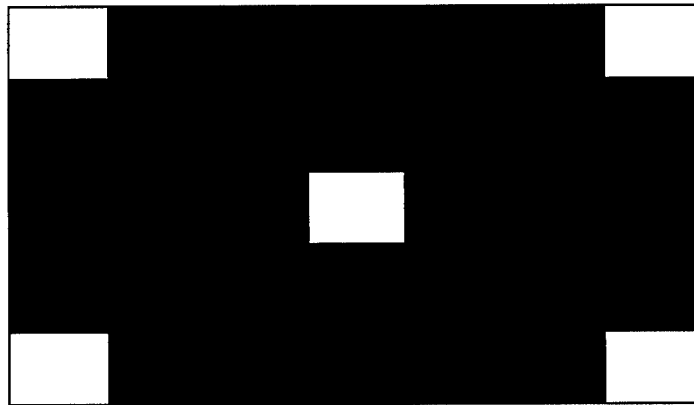

9.8" x 8.25" white targets, 5 places

Fig. II.B-1 Quantum Data "Brightness" test pattern with 11% duty factor depicted as projected onto the Stewart Studiotek 130 screen using the Electrohome 9501LC projector.

C. CONTRAST MODULATION

Reference: Color CRT Monitor Performance, Draft Version 2.0 Section 5.2, page 23.

For the 2000 x 1340 format, the average contrast modulation for 3-on/3-off white grille patterns at 50% L_{max} was 53% x 51% (Horizontal x Vertical) for nine sampled screen locations. Contrast modulation for 2-on/2-off grille patterns averaged 23% x 22% (HxV) and averaged 8% x 6% (HxV) for 1-on/1-off grille patterns.

For the 1280 x 1024 format, the average contrast modulation for 3-on/3-off white grille patterns at 50% L_{max} was 75% x 74% (HxV) over the screen. Contrast modulation for 2-on/2-off grille patterns averaged 49% x 53% (HxV) and averaged 10% x 18% (HxV) for 1-on/1-off grille patterns.

Contrast modulation was measured in both horizontal and vertical directions at nine screen positions for white in two formats, 2000 x 1340 and 1280 x 1024. The screen luminance was commanded to 50% maximum level. Four video modulation frequencies were examined using full screen grille test patterns consisting of alternating lines with n pixels on, n pixels off ($n=1,2,3,6$).

The contrast modulation for white grilles at screen center, and averaged over the eight peripheral screen positions, for 2000 x 1340 and 1280 x 1024 formats are presented in Figures II.C-1 and II.C-2.

The 2000 x 1340 data is displayed in Table II.C-1. The contrast modulation, C_m is reported (the defining equation is given in the Table). For horizontal and vertical 3-

on/3-off grilles the C_m is generally good (ranging from 40% to 67%, and the grilles are readily resolved over the entire screen. For the 2-on/2-off grille patterns, the modulation dropped as low as 13%. Contrast modulation (HxV) for 1-on/1-off grille patterns was only 12% or less at each of the nine screen locations including the center.

The 1280 x 1024 data is displayed in Table II.C-2. For horizontal and vertical 3-on/3-off grilles the C_m is generally quite high (ranging from 53% to 84%, and the grilles are readily resolved over the entire screen. For the 2-on/2-off grille patterns, the modulation dropped as low as 40%. Contrast modulation (HxV) for 1-on/1-off grille patterns ranged from 28% to as low as 6% at the nine screen locations including the center.

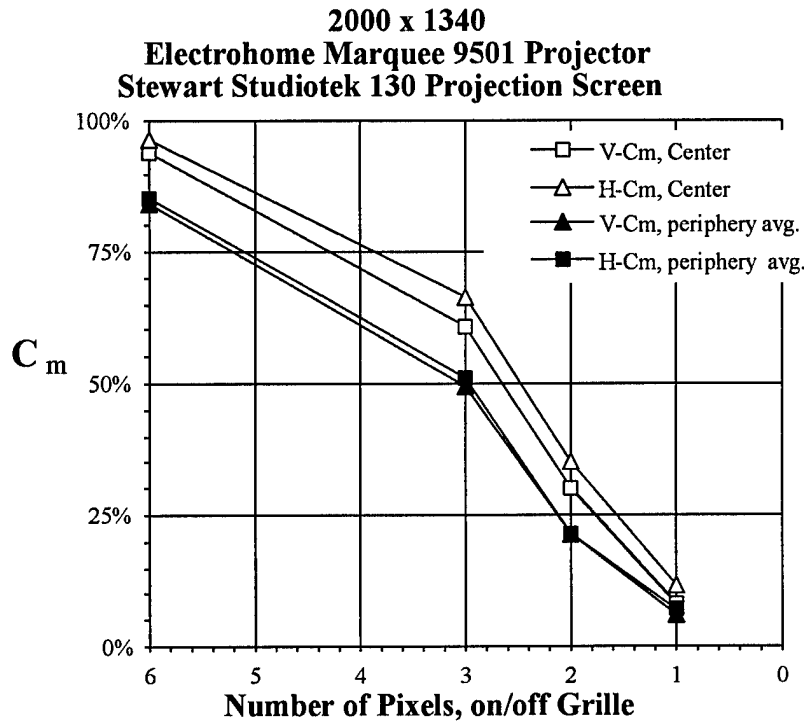

Fig. II.C-1 Plot of contrast modulation of white grilles at screen center, and averaged over the eight peripheral screen positions, obtained from test results for 2000 x 1340 format.

Table II.C-1. Contrast Modulation

Contrast Modulation (in %) at nine screen positions for four frequencies.

$$C_m = (L_{peak} - L_{valley}) / (L_{peak} + L_{valley})$$

Screen positions as indicated by position of data on page.

n x n indicates lines n pixels wide separated by n-pixel spaces (n-on / n-off).

Microvision OM-5 optic module used with Canon TV Zoom lens.

H = modulation in horizontal direction (vertical bars); V= modulation in vertical direction (horizontal bars).

C_m (%) - White at 50% L_{max} for 2000 x 1340 Format

| n x n | Screen luminance at 50% L _{max} . | | | | | |
|-------|--|---------|---------|---------|---------|---------|
| | Hgrille | Vgrille | Hgrille | Vgrille | Hgrille | Vgrille |
| | V-Cm | H-Cm | V-Cm | H-Cm | V-Cm | H-Cm |
| 6 | 80% | 83% | 96% | 94% | 83% | 82% |
| 3 | 54% | 50% | 62% | 64% | 54% | 49% |
| 2 | 24% | 27% | 30% | 30% | 23% | 20% |
| 1 | 6% | 6% | 9% | 7% | 6% | 8% |
| 6 | 82% | 76% | 94% | 97% | 84% | 85% |
| 3 | 44% | 49% | 61% | 67% | 50% | 48% |
| 2 | 17% | 24% | 30% | 35% | 20% | 13% |
| 1 | 4% | 8% | 8% | 12% | 6% | 7% |
| 6 | 83% | 88% | 90% | 95% | 78% | 82% |
| 3 | 47% | 52% | 43% | 56% | 42% | 40% |
| 2 | 20% | 23% | 16% | 22% | 21% | 14% |
| 1 | 6% | 8% | 7% | 8% | 6% | 7% |

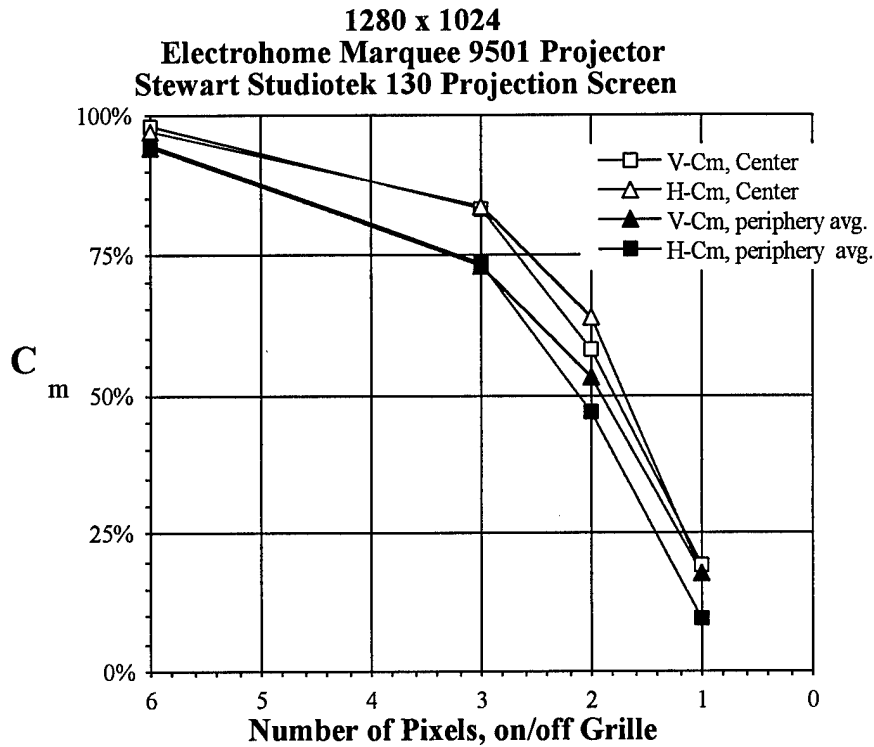

Fig. II.C-2 Plot of contrast modulation of white grilles at screen center, and averaged over the eight peripheral screen positions, obtained from test results for 1280 x 1024 format.

Table II.C-2. Contrast Modulation

Contrast Modulation (in %) at nine screen positions for four frequencies.

$$C_m = (L_{peak} - L_{valley}) / (L_{peak} + L_{valley})$$

Screen positions as indicated by position of data on page.

n x n indicates lines n pixels wide separated by n-pixel spaces (n-on / n-off).

Microvision OM-5 optic module used with Canon TV Zoom lens.

H = modulation in horizontal direction (vertical bars); V= modulation in vertical direction (horizontal bars).

C_m (%) - White at 50% L_{max} for 1280 x 1024 Format

| n x n | Screen luminance at 50% L _{max} . | | | | | |
|-------|--|---------|---------|---------|---------|---------|
| | Hgrille | Vgrille | Hgrille | Vgrille | Hgrille | Vgrille |
| | V-Cm | H-Cm | V-Cm | H-Cm | V-Cm | H-Cm |
| 6 | 91% | 91% | 98% | 96% | 98% | 94% |
| 3 | 78% | 72% | 84% | 82% | 78% | 69% |
| 2 | 49% | 47% | 66% | 54% | 60% | 45% |
| 1 | 6% | 14% | 28% | 11% | 22% | 7% |
| 6 | 93% | 93% | 98% | 97% | 96% | 98% |
| 3 | 79% | 73% | 83% | 84% | 77% | 77% |
| 2 | 59% | 47% | 58% | 64% | 58% | 48% |
| 1 | 20% | 8% | 19% | 18% | 24% | 7% |
| 6 | 91% | 92% | 93% | 98% | 94% | 96% |
| 3 | 64% | 70% | 53% | 73% | 71% | 72% |
| 2 | 40% | 42% | 48% | 47% | 44% | 44% |
| 1 | 9% | 7% | 17% | 9% | 17% | 12% |

D. CONTRAST RATIO

Reference: ANSI Standard No. IT7.227 and IT7.215.

For the 2000 x 1340 format, the average luminance contrast ratio for 4 x 4 chessboard patterns displayed at 100% Lmax was 98:1 over the projection screen. Full screen contrast ratio is 33:1 including halation effects.

For the 1280 x 1124 format, the average luminance contrast ratio for 4 x 4 chessboard patterns displayed at 100% Lmax was 147:1 over the projection screen. Full screen contrast ratio is 32:1 including halation effects.

Luminance was measured in both horizontal and vertical directions at 16 screen positions for white and black rectangular targets simultaneously displayed in a 4 x 4 chess board configuration as specified by ANSI IT7.215. The screen luminance was commanded to 100% maximum level.

The data is displayed in Table II.D-1. The contrast ratio, CR is reported (the defining equation is given in the Table).

Full screen contrast ratio measured under dark room conditions for full screen white (11.55 fL) and black (4.45 mFL) is reduced from 2595:1 to less than 33:1 when halation effects of 3.13% are included.

2000 X 1340

Table II.D-1. Contrast Ratio = (Lwhite / Lblack)

Screen positions as indicated by position of data on page.

ANSI Chessboard Luminance (in fL) Includes projection screen.

| | | | |
|-------|-------|-------|-------|
| 8.90 | 0.111 | 11.8 | 0.072 |
| 0.108 | 16.1 | 0.167 | 10.3 |
| 11.6 | 0.234 | 17.0 | 0.104 |
| 0.077 | 15.3 | 0.148 | 8.96 |

Luminance of
projector and screen

| | |
|-----------|----------|
| Avg white | 12.5 fL |
| Avg black | 0.127 fL |
| Avg CR | 98 |

1280 X 1024

Table II.D-2. Contrast Ratio = (L_{white} / L_{black})

Screen positions as indicated by position of data on page.

ANSI Chessboard Luminance (in fL) Includes projection screen.

| | | | |
|-------|-------|-------|-------|
| 13.5 | 0.095 | 17.1 | 0.058 |
| 0.091 | 22.9 | 0.185 | 16.8 |
| 17.6 | 0.238 | 24.2 | 0.107 |
| 0.076 | 20.2 | 0.151 | 14.6 |

Luminance of
projector and screen

| | |
|-----------|----------|
| Avg white | 18.4 fL |
| Avg black | 0.125 fL |
| Avg CR | 147 |

E. SYSTEM GAMMA

Reference: Color CRT Monitor Performance, Version 2.0 Section 4.2, page 11.

The value found for gamma of white is 2.04 . The whitepoint chromaticity shifted by 0.020 ?u'v' units at a screen luminance of 1% Lmax. (A change of 0.004 ?u'v' units is visible.)

Luminance at center screen for a 100% full screen size box was measured for twenty different input voltage levels ranging from 0 to 255 digital counts. Table II.E-1 shows the data. Figures II.E-1 and II.E-2 illustrate the white luminance and chromaticity data, respectively. The system gamma is defined as the slope of the curve in the log-log plot. Since the curve is nonlinear, a unique value of gamma does not exist. A single value was derived for the high-end luminance range.

The gamma value obtained for white in 1280 x 1024 format was 2.04 from about 0.067 fL to 14.0 fL (15 to 255 counts).

The grayscale shift in chromaticity of the whitepoint for 1280 x 1024 format around 1% Lmax (0.14 fL) exceeded 0.020 ?u'v' units relative to 100% Lmax (14 fL). ?u'v' of 0.004 units is visible.

Table II.E-1. System Gamma

Luminance (in fL) of projector and screen at center screen as a function of input counts.

| <u>Input level</u> Counts | <u>Full Screen</u> 1280 x 1024 | | |
|------------------------------|-----------------------------------|--------|--------|
| | L (fL) | CIE x | CIE y |
| Black, 0 | 0.00526 | 0.3306 | 0.4988 |
| 1 | 0.00640 | 0.3022 | 0.4973 |
| 2 | 0.00886 | 0.2872 | 0.4928 |
| 3 | 0.01002 | 0.2845 | 0.509 |
| 7 | 0.02264 | 0.2923 | 0.4684 |
| 15 | 0.06708 | 0.2834 | 0.3986 |
| 23 | 0.1458 | 0.2892 | 0.3744 |
| 31 | 0.2589 | 0.2901 | 0.3621 |
| 39 | 0.4089 | 0.2916 | 0.3547 |
| 47 | 0.6145 | 0.292 | 0.348 |
| 63 | 1.149 | 0.2901 | 0.338 |
| 79 | 1.882 | 0.2872 | 0.3285 |
| 95 | 2.805 | 0.2838 | 0.3192 |
| 111 | 4.029 | 0.2808 | 0.3122 |
| 127 | 5.614 | 0.2792 | 0.3082 |
| 143 | 7.421 | 0.2798 | 0.3092 |
| 159 | 9.39 | 0.2832 | 0.3147 |
| 191 | 13.87 | 0.2914 | 0.3295 |
| 223 | 13.96 | 0.292 | 0.3312 |
| White, 255 | 13.97 | 0.2914 | 0.3321 |

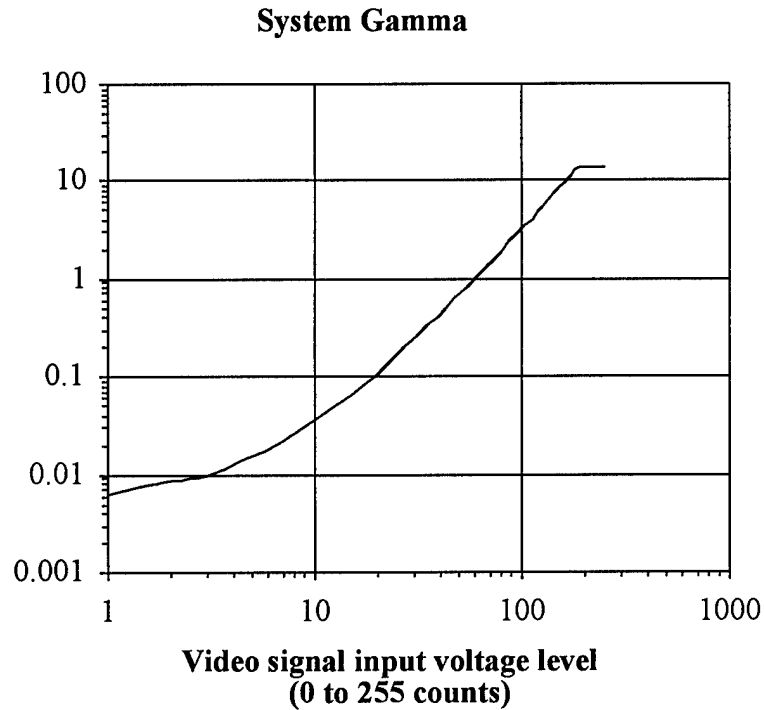

Fig. II.E-1. Log-log plot of input counts versus luminance for a white full screen.

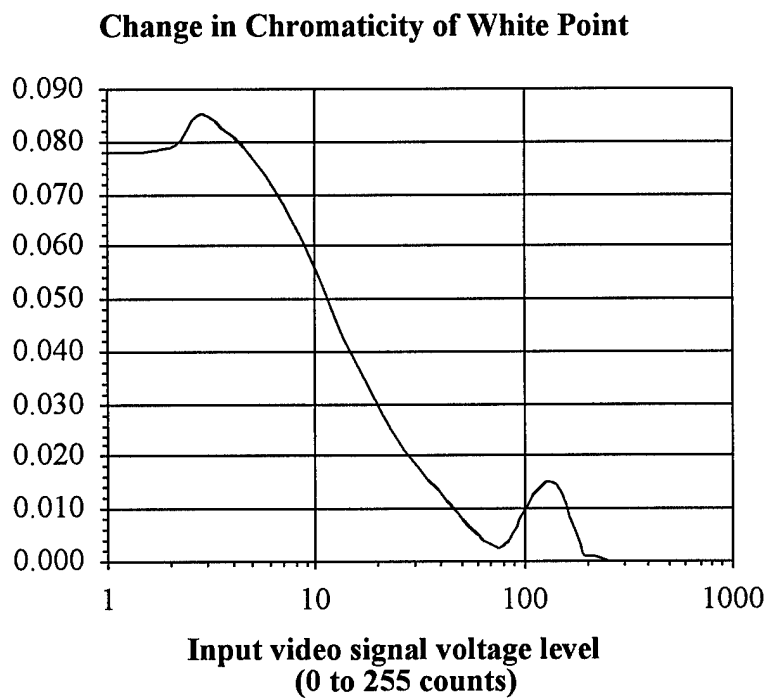

Fig. II.E-2. Plot of input counts versus chromaticity shift in $u'v'$ units relative to white full screen at L_{max} (input count 255).

F. HALATION

Reference: Color CRT Monitor Performance, Draft Version 2.0 Section 4.6, page 16.

Halation was only 3.1% on a small black patch surrounded by a large full white area.

Halation is the phenomenon by which the luminance of a given region of the screen is improperly increased by contributions from surrounding more luminous areas. Sources of halation include light scattering within the CRT phosphor layer and internal reflections inside the glass faceplate and the projector lens assembly. Halation is undesirable as it degrades the contrast of displays.

Halation is determined by measuring the luminance, L_b , of a small (50 pixels wide, approximately 0.2% of the screen area) square commanded to L_{min} when surrounded by an otherwise full white screen (1280 x 1024 pixels) commanded to L_{max} . In this case, full screen L_{max} is equal to 9.94

fL while full screen L_{min} is only 0.012 fL. Halation is then defined numerically as:

$$\% Halation = 100 \times (L_b - L_{min}) / L_{max} ,$$

where L_{max} is the full screen white luminance, L_{min} is the full screen black luminance, and L_b is the measured luminance of the small square when the surrounding image area is commanded to white at L_{max} .

The measured data and derived values of halation are presented in Table II.K-1 and Fig. II.K-1. The luminance of the small black square is seen to increase by 3.1% L_{max} when as the outer bright patch is displayed at L_{max} .

Table II.K-1. Halation

| <u>$L_{min}(fL)$</u> | <u>$L_{max}(fL)$</u> | <u>$L_b(fL)$</u> | <u>% Halation</u> |
|---------------------------------|---------------------------------|-----------------------------|-------------------|
| 0.012 | 9.94 | 0.323 | 3.1 |

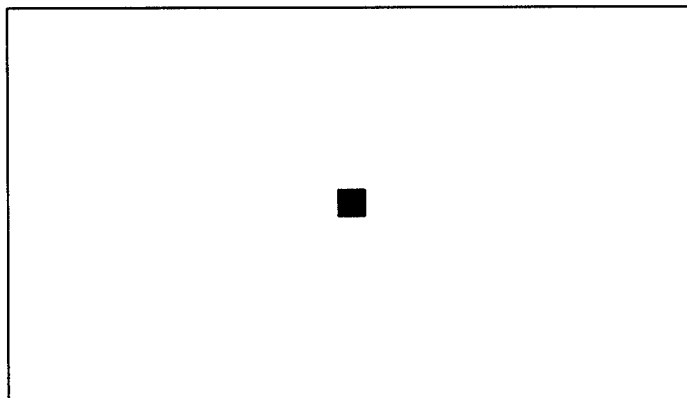

Fig. II.F-1. Halation test pattern: 50-pixel wide black square, approximately 0.2% of the total image area on full white background of 1280 x 1024 pixels (61.25 x 49 inches).

Section III

ANALYSIS AND CONCLUSIONS

The most important performance characteristic of a projection display is resolution. Measures of resolution are the contrast modulation at the stated addressability and the number of resolvable pixels. At its tested addressability of 2000 x 1340 pixels, the Electrohome 9501LC projector and Stewart Studiotek 130 projection screen achieves a nine-point average white contrast modulation of less than 12% everywhere on the screen. Using linear interpolation and the contrast modulation measurements for 1-on/1-off, 2-on/2-off, and 3-on/3-off patterns, the number of resolvable pixels at 50% Lmax is:

2000 x 1340 addressability

- 1041 x 673 @ $C_m = 25\%$
- 698 x 456 @ $C_m = 50\%$

1280 x 1024 addressability

- 1033 x 916 @ $C_m = 25\%$
- 642 x 569 @ $C_m = 50\%$

A contrast modulation of 25% or more is clearly perceivable and appropriate for the display of imagery. A contrast modulation of 50% or more is appropriate for the display of small-size alphanumeric information.

For 2000 x 1340 format, the 3-on/3-off grilles (horizontal and vertical, of Table II.C-1) exhibited measured C_m values exceeding 50% at a majority of the nine screen points, showing that information at these frequencies is definitely resolved. For the white 2-on/2-off grilles, the C_m values fall below 25% in many areas.

For 1280 x 1024 format, the 2-on/2-off grilles (horizontal and vertical, of Table II.C-2) exhibited measured C_m values exceeding 50% at several of the nine screen points, showing that information at these frequencies is definitely resolved. For the white 1-on/1-off grilles, most C_m values are below 25% and fall as low as 6%.

A potential contribution to the loss of contrast modulation is misconvergence. The principal effect of misconvergence is the effective broadening of white lines. The misconvergence of the Electrohome 9501LC projected image was visually assessed to be on the order of less than one pixel size (36.6 x 36.6 mils) at all locations on the screen. Misconvergence >1.5 to 2 pixels can significantly degrade resolution. Misconvergence < 1.0 pixel is typically not an important factor because the relative perceived luminosities of red and blue are considerably less than that of green.

APPENDIX A

DEFINITIONS - MEASUREMENT TERMS

- Addressability:** Measure of the accuracy with which an electron beam spot is placed at discrete positions on the screen. The inter-pixel distance [TEP 192]. Defines how precisely one can position the electron beam spot on the screen.
- ANSI Lumen** Quantification of visible light power (in lumens) of a projection display, defined in ANSI standard IT7.228 as the average of nine illuminance values in lux measured at specified locations within the projected image area, multiplied by the area of the image in square meters.
- ANSI Pixel** Quantification of display resolution in pixels of a projection display, defined in ANSI standard IT7.228 as the highest spatial frequency (or greatest number of pixels) which does not degrade modulation depth below 30% of the low-frequency modulation depth, specifically that of the 4 x 4 checkerboard pattern. The modulation depth is defined in IT7.228 as the (peak - valley) luminance of a 1-on/1-off grille relative to the average (white - black) luminance of the ANSI large-area 4 x 4 checker board test pattern.
- Chromaticity Uniformity** Measure of how chromaticity vary across the screen. Chromaticity should be as uniform as possible.
- Contrast Modulation (Cm):** A measure of relative luminances, L_{peak} , L_{valley} , over a distance of multiple cycles of high and low states in a displayed grille test pattern.
- Monitors with contrast modulation greater than 25% are generally acceptable for the display of images while the display of text generally calls for contrast modulation greater than 50%.
- Contrast Ratio (CR)** The ratio of a higher luminance to a lower luminance.
- Convergence:** Measure of the separation in landing positions of separate beams directed toward the same point on the screen. The main misconvergence errors involve blue-to-red separations and green-to-red-blue-average separations (coma), and are measured in both horizontal and vertical directions. Misconvergence errors exceeding pixel size degrade contrast modulation and may cause spurious color fringes at edges in images.
- Halation** Phenomenon by which the luminance of a given region of the screen is improperly increased by contributions from surrounding more luminous areas. Sources of halation include light scattering within the CRT phosphor layer and internal reflections inside the glass faceplate and the projector lens assembly. Halation is undesirable as it degrades the contrast of displays.

| | |
|---------------------------------|---|
| Illuminance | Refers to the amount of light falling upon a surface, in this case, luminous flux from the projector incident on the surface per unit area of the front projection screen. 1 lux = 1 lumen/square meter = 0.0929 footcandle. |
| Luminance | A quantification of the brightness of a surface, in this case, luminous flux per unit solid angle per unit area emitted in a given direction from the surface of the front projection screen. 1 fL = 3.4263 candela per square meter (cd/m^2), $1 \text{ cd}/\text{m}^2 = 1 \text{ lumen per steradian per square meter}$. |
| Minimum Luminance (Lmin) | Luminance of the display screen when the input signal corresponding to that portion of the screen is at the lowest level, e.g., level 0 for an 8-bit display. |
| Maximum Luminance (Lmax) | Luminance of the display screen when the input signal corresponding to that portion of the screen is at the highest level, e.g., level 255 for an 8-bit display. |
| Luminance Stability | Measure of variation in luminance as a function of the fraction of screen area that is being lit (i.e., the fraction of the frame time in which the electron beam is actually turned on). |
| Luminance Uniformity | Measure of how luminance varies across the screen. Luminance should be as uniform as possible. |
| Resolution: | Measure of the ability to delineate picture detail; i.e., ability to distinguish two adjacent spots on the screen. |
| Screen Gain | The ratio of the reflected or transmitted luminance of a projection screen to the luminance of a Lambertian reflector which reflects all of the incident light uniformly in all directions. Screen gain is usually specified for the viewing angle that is perpendicular to the surface of the screen. |
| System Gamma: | The slope of the curve in a log-log plot of output luminance vs. input drive <i>at the monitor terminals</i> . Note that this definition includes any modification to the drive curve by the internal boards on the monitor – thus the term <i>System Gamma</i> . |
| Warmup Characteristic: | Time required for the luminance to stabilize at some predetermined value (typically $\pm 1\%$). |

DISPLAY EVALUATION REPORT

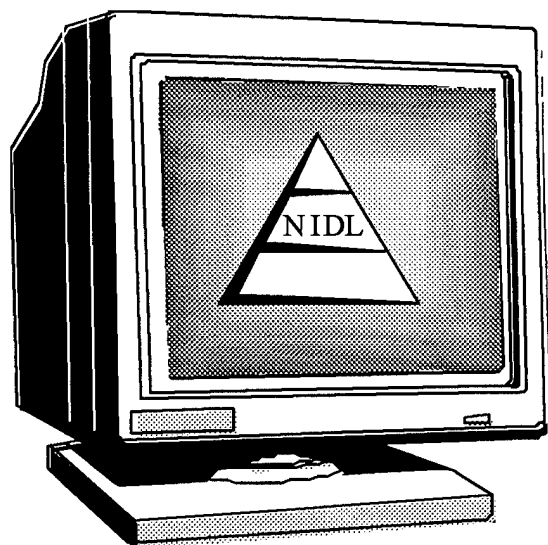

A Survey of Twenty Color CRT Monitors

- Size range: 20 to 21 inch
- Addressability: 1600 x 1280
or 1600 x 1200

Monitors Included:

Aydin Controls 9010P
Barco CCID 121
Cornerstone Color 21/80
Goldstar 2010
Hitachi HM-6821-D
Iiyama MF-8221E
MAG InnoVision MX21F
MiTAC L2182
Mitsubishi Diamond Pro 21TX
Nanao FlexScan F780i•W
NEC MultiSync XP21
Nissei Sangyo SuperScan Supreme 21
Orwin C1632 (upgraded)
Panasonic Panasonic/Pro C-2192P
Philips 2130DC
Sampo AlphaScan GLX
Sigma ColorFX 21E
Sony Multiscan 20se
Tatung CM20MKR
ViewSonic 21PS

National Information Display Laboratory

at the

David Sarnoff Research Center
CN 5300, Princeton, NJ 08543-5300

January 17, 1997

Publication No. 5721096-053

Approved for public release; distribution is unlimited.

NOTICE:

This report was prepared on behalf of the National Information Display Laboratory (NIDL) by David Sarnoff Research Center, Inc. (SARNOFF) as an account of work sponsored by the United States Government. The United States Government, the NIDL and SARNOFF, and any person acting on their behalf:

- A. Makes no warranty or representation, expressed or implied, with respect to the use of any information contained in this report, or that the use of any information, apparatus, method, or process disclosed in this report is free from infringement of any third party rights; or
- B. Makes no endorsement of any of the products reported on herein; or
- C. Assumes no liabilities with respect to the use of, or for damages resulting from the use of, any information, apparatus, method, or process disclosed in this report.

DISPLAY EVALUATION REPORT

National Information Display Laboratory

| | |
|--|-----------|
| INTRODUCTION: PURPOSE OF THIS REPORT | 1 |
| Understanding the Measurements and Charts | 1 |
| COMPARATIVE DATA ON TWENTY MONITORS..... | 3 |
| Luminance | 3 |
| Resolution..... | 4 |
| Misconvergence | 9 |
| Waviness..... | 10 |
| INDIVIDUAL DATA ON EACH OF TWENTY MONITORS..... | 12 |
| Aydin Controls 9010P..... | 13 |
| Barco CCID 121 | 15 |
| Cornerstone Color 21/80..... | 17 |
| Goldstar 2010..... | 19 |
| Hitachi HM-6821-D..... | 21 |
| Iiyama MF-8221E | 23 |
| MAG InnoVision MX21F | 25 |
| MiTAC L2182 | 27 |
| Mitsubishi Diamond Pro 21TX | 29 |
| Nanao FlexScan F780i•W..... | 32 |
| NEC MultiSync XP21..... | 34 |
| Nissei Sangyo SuperScan Supreme 21 | 36 |
| Orwin C1632 (upgraded) | 39 |
| Panasonic Panasonic/Pro C-2192P | 42 |
| Philips 2130DC..... | 44 |
| Sampo AlphaScan GLX..... | 46 |
| Sigma ColorFX 21E | 48 |
| Sony Multiscan 20se | 50 |
| Tatung CM20MKR..... | 52 |
| ViewSonic 21PS..... | 54 |

THIS PAGE INTENTIONALLY LEFT BLANK

FORWARD

On behalf of the government user community, the National Information Display Laboratory (NIDL) has prepared this report which surveys the performance of twenty color CRT monitors. All have addressability of either 1600 x 1280 or 1600 x 1200 pixels, and image sizes from 20 to 21 inches. The report presents summaries of the most important monitor parameters, plus comparisons of the twenty monitors based on those parameters.

The NIDL has also prepared a series of individual evaluations of high-resolution display monitors. These detailed reports help government users to obtain, at reasonable cost, display monitors with the required performance. The reports can be obtained from the NIDL at the address listed below.

Two companion documents that describe how the measurements are made are also available from the NIDL:

- *NIDL Publication No. 313794-024*
Display Monitor Measurement Methods under Discussion by EIA (Electronic Industries Association) Committee JT-20,
Part 1: Monochrome CRT Monitor Performance, Draft Version 1.0.
- *NIDL Publication No. 313794-025*
Display Monitor Measurement Methods
under Discussion by EIA (Electronic Industries Association) Committee JT-20,
Part 2: Color CRT Monitor Performance, Draft Version 1.0.

The above measurement procedures were developed by the NIDL in collaboration with the display industry and are currently under review in EIA and ANSI Committees and with the National Institute of Standards and Technology.

Comments, suggestions, and questions about this report are welcome and encouraged.

The NIDL can be reached at:

National Information Display Laboratory
P. O. Box 8619
Princeton, NJ 08543-8619
Tel: (609) 951-0150
Fax: (609) 734-2313
e-mail: nidl@maca.sarnoff.com

THIS PAGE INTENTIONALLY LEFT BLANK

Introduction: Purpose of This Report

This report presents a survey of the performance of twenty color CRT monitors. All have addressability of either 1600 x 1280 or 1600 x 1200 pixels, and image sizes from 20 to 21 inches. The report provides:

- Comparisons of the performance of the twenty monitors
- A two page summary of the performance of each of the twenty monitors

The results are given in a standardized graphical format.

The purpose of the report is to provide an overview of the performance of these monitors. To do that, we have concentrated on the most important monitor parameters, providing the reader with information that will allow a rapid and timely review.

These parameters are:

- Luminance (brightness)
- Resolution (measured and interpreted in several ways)
- Convergence
- Waviness (distortion)

In color monitors, the desired image can beat with the phosphor dots or stripes leading to a disturbing pattern of wavy bars called Moiré. Moiré is difficult to quantify; it is very apparent to the eye in some images, but not in others. In this report we refer to Moiré only in the Comments sections of the individual monitor reports in the following section.

The NIDL has published a detailed description of the procedures used to make the measurements we report here, as well as many others needed for a complete characterization of a CRT monitor. [See references in Forward, p. iii.]

UNDERSTANDING THE MEASUREMENTS AND CHARTS

We provide a brief explanation of each measured parameter just before we present the measurements of that parameter. With the exception of waviness (geometric distortion), all measurements were made at nine positions on the monitor screens:

- the center of the screen,
- top and bottom (12 and 6 o'clock),
- right and left (3 and 9 o'clock),
- four corners (2, 4, 8, and 10 o'clock).

This allows us to assess both the behavior at the center of the screen and the variation as one moves around the screen.

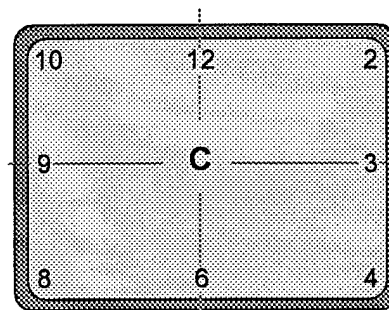

For simplicity, measurements are reported using only four kinds of charts.

(1) A radar chart is used to show measurements at the nine positions across the screen for each monitor. The example in Fig. 1 shows luminance data for one monitor. (Luminance in foot-Lamberts, described later.) The radius of the shaded region indicates the magnitude of the parameter.

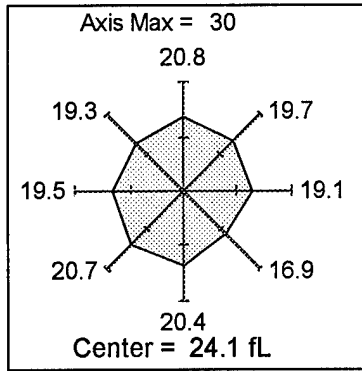

Figure 1. An example of a radar type of chart showing luminance at center and eight other positions on the screen. In this plot, luminance at screen center is 24.1 fL, at screen top it is 20.8 fL, etc. The full-scale length of each radial line is given as 30 fL.

(2) Horizontal high-low-center bar charts are used to compare monitors as in Fig. 2. Minimum and maximum values plus the value at center screen are shown in charts of the type illustrated in Fig. 2.

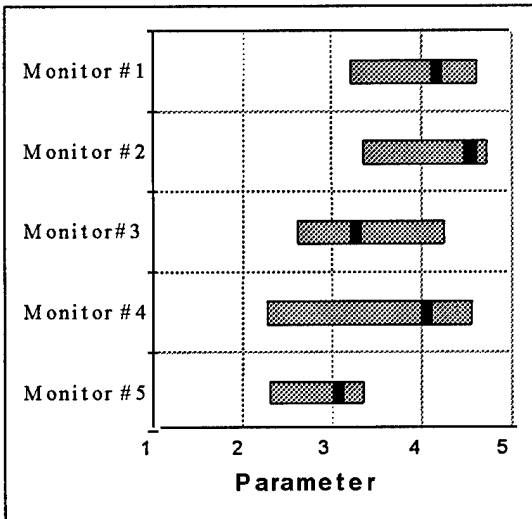

Figure 2. An example of a bar chart showing the range from the minimum to the maximum values measured, with the value at screen center indicated by the dark bar. This chart shows that the minimum and maximum values for Monitor #1 were 3.2 and 4.6 and the center screen value was 4.2.

(3) A conventional bar chart is illustrated in Fig. 3, in which the length of the bar indicates the value of the measured parameter. The left edge of the bar has no significance.

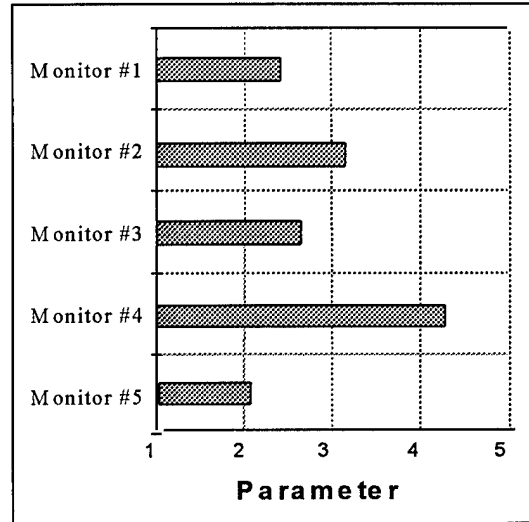

Figure 3. An example of a bar chart showing a value of 3.2 for Monitor #2.

(4) The final type of chart is used to show waviness, or geometric distortion. The irregular lines are exaggerations of the shape of perfect straight lines as displayed across the center and along the edges of the monitor.

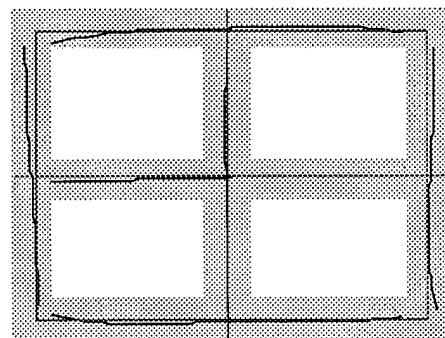

Figure 4. An example of the chart used to show waviness, or geometric distortion. The gray band indicates $\pm 1.0\%$ distortion.

Comparative Data on Twenty Monitors

LUMINANCE

Luminance is the technical name for the brightness of a monitor. It is measured in foot-Lamberts (fL). The typical home television receiver provides about 100 fL brightness. Most good quality color CRT monitors used with computers or other technical display applications have average luminances of 25 to 30 fL. The lower luminance is related to the higher resolution of these monitors.

Higher brightness is usually accompanied by a decrease in resolution and, sometimes, in contrast as well. When comparing monitor performance one needs to consider that all these parameters can be traded off. An ideal monitor achieves high resolution, brightness, and contrast simultaneously.

The values shown in Fig. 5 were measured using a PhotoResearch SpectraScan PR-704 spectroradiometer with the monitor set to the maximum drive specified by the manufacturer. The drive is maintained for the full screen.

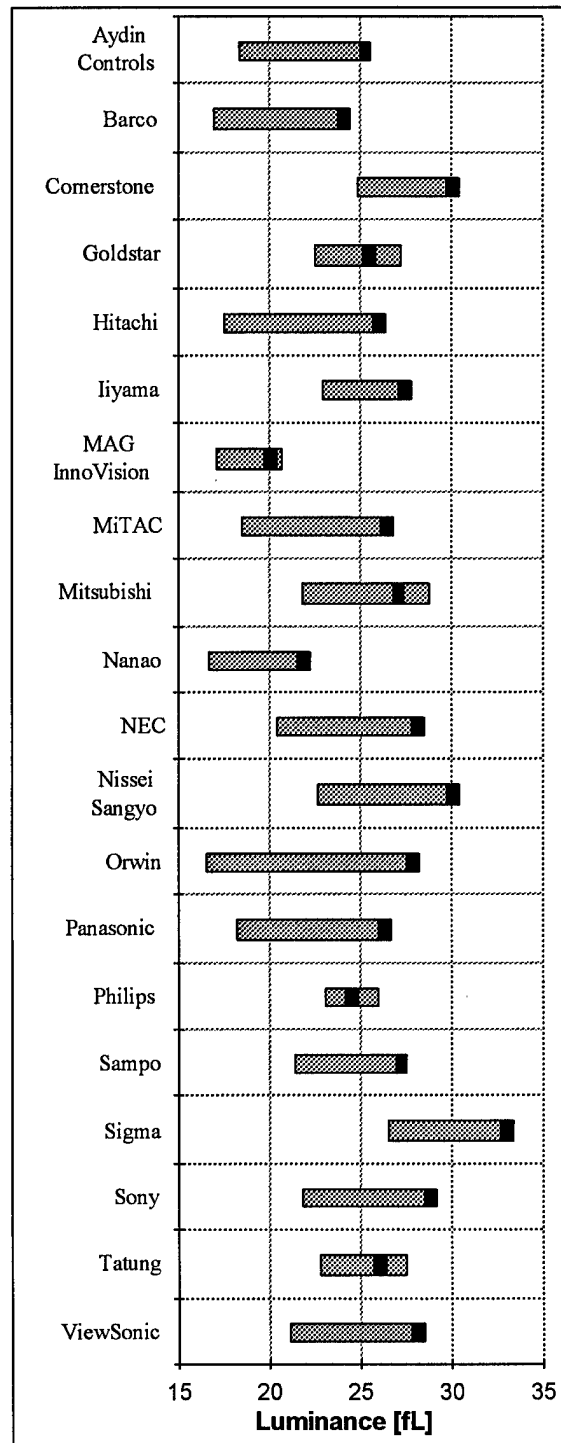

Figure 5. Measured luminance of the twenty monitors. Center screen luminance, indicated by the black bar, is usually also the maximum luminance.

RESOLUTION

Discussion of Resolution and Addressability

Resolution is often the first specification one asks about a monitor, but it is just one of the important parameters.

It is essential to distinguish between the concepts of *addressability* and *resolution*:

- *Addressability* states the number of locations at which a dot can be displayed on the screen. The displays in this report all have an addressability of 1600 positions horizontally and either 1200 or 1280 positions vertically. These are the numbers that monitor manufacturers often give in describing the display resolution. However, that does not guarantee that the spot of light is small enough to actually distinguish adjacent addressable spots.
- *Resolution* measures the actual number of spots or lines that can be distinguished across the screen. The electron beam that forms the spot on the screen has a finite width, causing the spot to grow. The video electronics also have finite risetime, stretching the spot along the scanning (horizontal) direction. As the spots grow and begin to overlap, the ability to discern them as individual spots decreases.

The resolution of a color CRT display is further limited by the pattern of red, green and blue dots or stripes on the screen. The spacing of the three color dots or stripes determines the minimum size that a white pixel can have. That sets the limit for the number of white pixels that can be displayed. For example a 20-inch diagonal tube with a viewable width of 14 inches (355 mm) and a phosphor stripe spacing of 0.3 mm (0.3 mm from one group of RGB stripes to the next) is limited to no more than 1183 white pixels horizontally.

The Concept of Contrast Modulation

Contrast modulation, C_m , is the best and most complete description of the ability of a monitor to display information. It directly measures the ability of the CRT to reproduce desired luminance patterns. The process is shown schematically below.

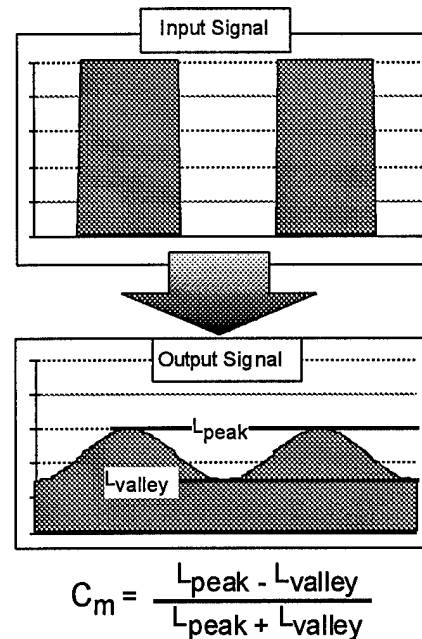

Figure 6. Contrast modulation, C_m . A fully modulated signal is input to the monitor. The contrast in the resulting screen pattern is measured.

C_m is reported here at just one frequency, although a complete characterization of a display requires C_m as a function of frequency. The frequency used in these measurements is called the 1-on/1-off frequency, and is the highest frequency that a display should produce. Adjacent pixels are turned full on and full off, in both the horizontal or vertical directions. The pattern produced is either vertical or horizontal stripes on the screen, each black or white stripe being one pixel wide. The extent to which the actual displayed light pattern changes from full white to full black is the Contrast Modulation, C_m , as indicated in Fig. 6.

Contrast Modulation Results

For this report, Cm was measured using a MicroVision Display Characterization system, a line-scan camera that scans the tube face and maps out the intensity of the pattern.

If the display were perfect, the screen would show a series of full white bars with perfectly black bars between them, yielding a Cm of 100%. In reality, several factors combine to spread the light out so that the pattern is one of light and dark gray bars, not black and white. Among these are:

- The ability of the display to form a narrow line.
- The accuracy with which the three color beams come together, called convergence (discussed below).
- Halation - the leakage of light from bright areas of the image into the dark areas because of reflections off the glass and the phosphor surface.

The comparison of Cm for the twenty monitors is shown in Fig. 7. A perfect display would have Cm = 100%, but that is not expected in any real display. The significance of Cm in the range of 25 to 50% is discussed in the following section.

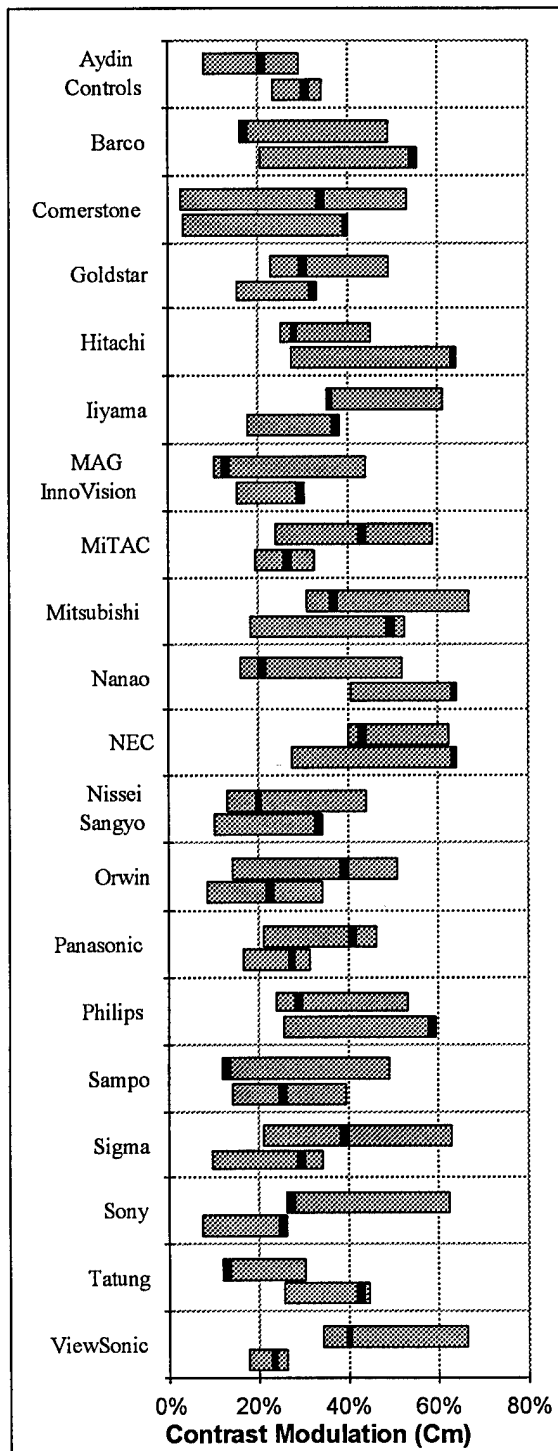

Figure 7. Measured contrast modulation Cm of the twenty monitors for the 1-on/1-off test pattern. The upper bar shows vertical modulation (horizontal stripes); the lower bar shows horizontal modulation (vertical stripes).

Realizable resolution: a simple number

For more information see the publications on Page *iii*.

Describing resolution with a simple number, such as 1600 x 1200 pixels, is an approximation to a complicated subject. To be meaningful, that number must be defined precisely. We define resolution here as the number of alternate black and white lines that can be displayed with a stated minimum contrast modulation, reducing visibility. Displaying more pixels than that will lower the contrast below the minimum.

We use two criteria to allow us to assign meaningful numbers to realizable resolution for two common applications. We state the total number of black lines plus white lines, and give the values for horizontal and vertical resolution separately.

- *Text resolution* (and graphics) require crisp edge definition and clear whites and blacks. We define the resolution for this use as the maximum number of alternating black and white lines that can be displayed with a Cm of 50% or more. A Cm of 50% produces alternating lines that are highly visible.
- *Image resolution* typically does not require sharp changes in luminance. For monitors displaying images rather than text, we define the resolution using a minimum Cm of only 25%. A pattern of alternating black and white lines with 25% contrast is still visible.

Since these definitions demand a higher Cm for text than for images, the stated resolution is always lower for text.

The comparison of realizable resolution for the twenty monitors is shown in Fig. 8.

Using the 25% Cm imaging criterion, a few of the monitors achieve approximately the full 1600 x 1280 or 1200 resolution one might expect from the addressability. None of them reaches that resolution if the 50% Cm criterion is used.

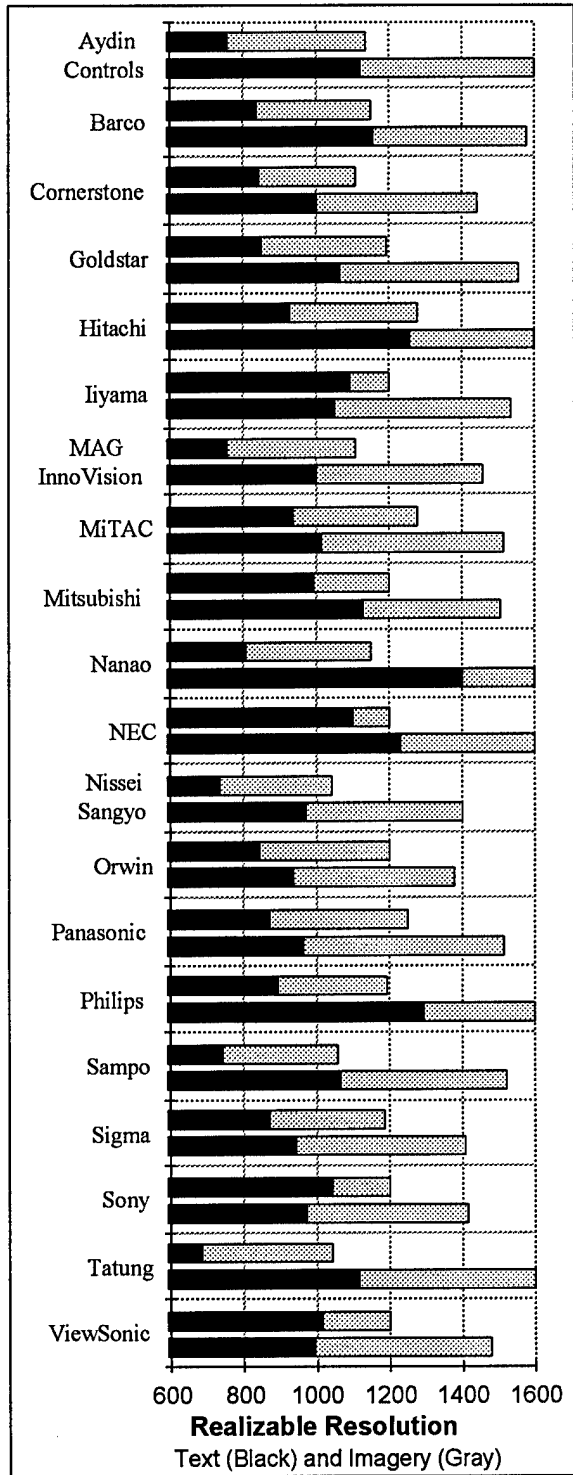

Figure 8. Realizable resolution. The upper bar shows vertical modulation (horizontal stripes), the lower bar shows horizontal modulation (vertical stripes).

Resolution-Addressability Ratio (RAR)

Another well known measure of monitor performance is called the *Resolution-Addressability Ratio* or RAR. It is the ratio of the size of the actual spot (or line) produced to the size of the pixel. The size of the pixel is determined by the scanned image size divided by the addressable number of pixels. RAR can also be thought of as the width of the line measured in addressable pixels. An RAR of 1.0 would mean that the addressability and resolution are equal, i.e. that the spot is just small enough to display the addressable number of pixels as separated individual dots. If the RAR is greater than one, then the spot is too large to display each pixel separately. However, in a typical display, RAR is set to be between 1.2 and 1.3. The slightly larger spot causes adjacent spots to overlap a little, and reduces the Cm to about 50%, but reduces Moiré and the visibility of scan lines. As the RAR increases beyond 1.5, the Cm decreases markedly. Thus an RAR of 1.5 or more shows that the monitor cannot produce an image as sharp as the addressability implies.

The comparison of RAR for the twenty monitors is shown in Fig. 9. Note that the RARs for many of the monitors are between the desirable limits of 1.2 and 1.5 at screen center. Remember that in this style of chart, the ends of the indicated bar are the minimum and maximum values, which may occur at only a small portion of the screen.

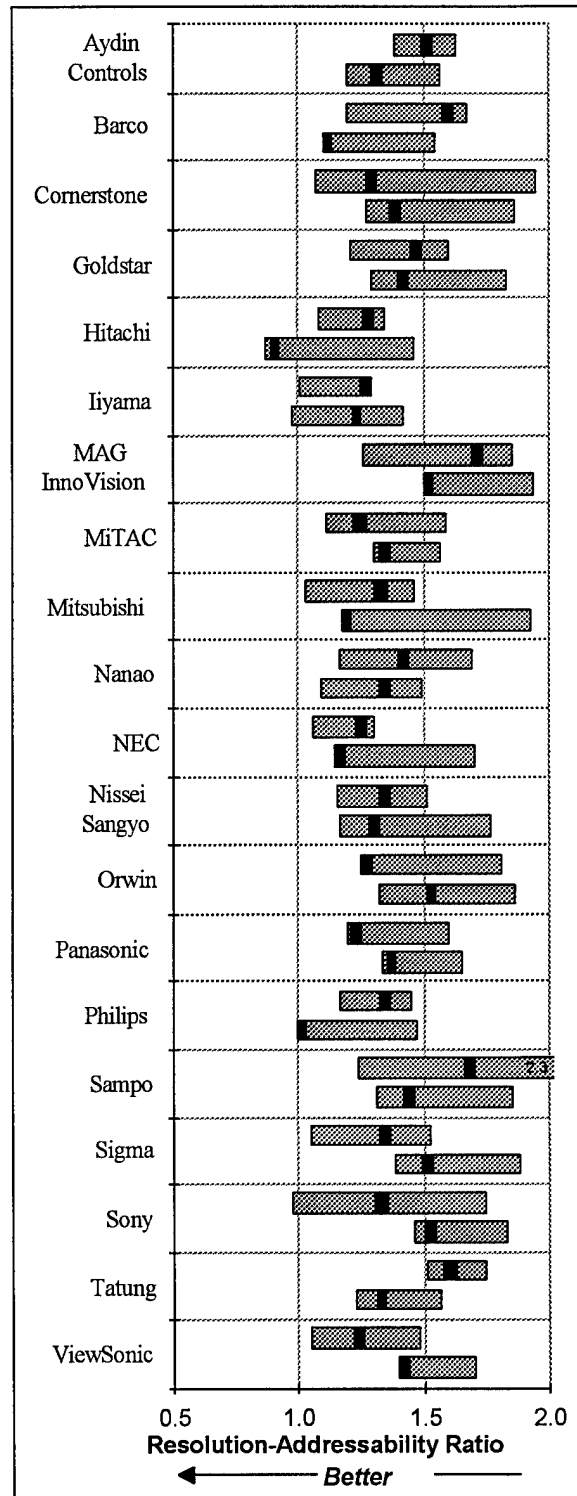

Figure 9. Resolution-Addressability Ratio or RAR. RAR of 1.2 is considered optimum. For RAR larger than 1.5, the spot is too large to display all the addressable pixels. The upper bars show vertical resolution, the lower bars horizontal.

MISCONVERGENCE

Color CRTs make a given hue by combining precise amounts of red, green, and blue light, generated by appropriate phosphors excited by three separate electron beams. For the color rendition to be correct and to minimize the effective size of the resultant white spot, the three beams must overlap completely at each addressable position on the screen. Because of the limitations in the beam deflection system, perfect registration, called *convergence* in CRTs, is not possible. The misconvergence parameter as used here describes the larger of the difference in the landing position between the red and green beams or the blue and green beams. Clearly a misconvergence of more than a pixel will result in noticeable degradation of the display.

The comparison of misconvergence for the twenty monitors is shown in Fig. 10.

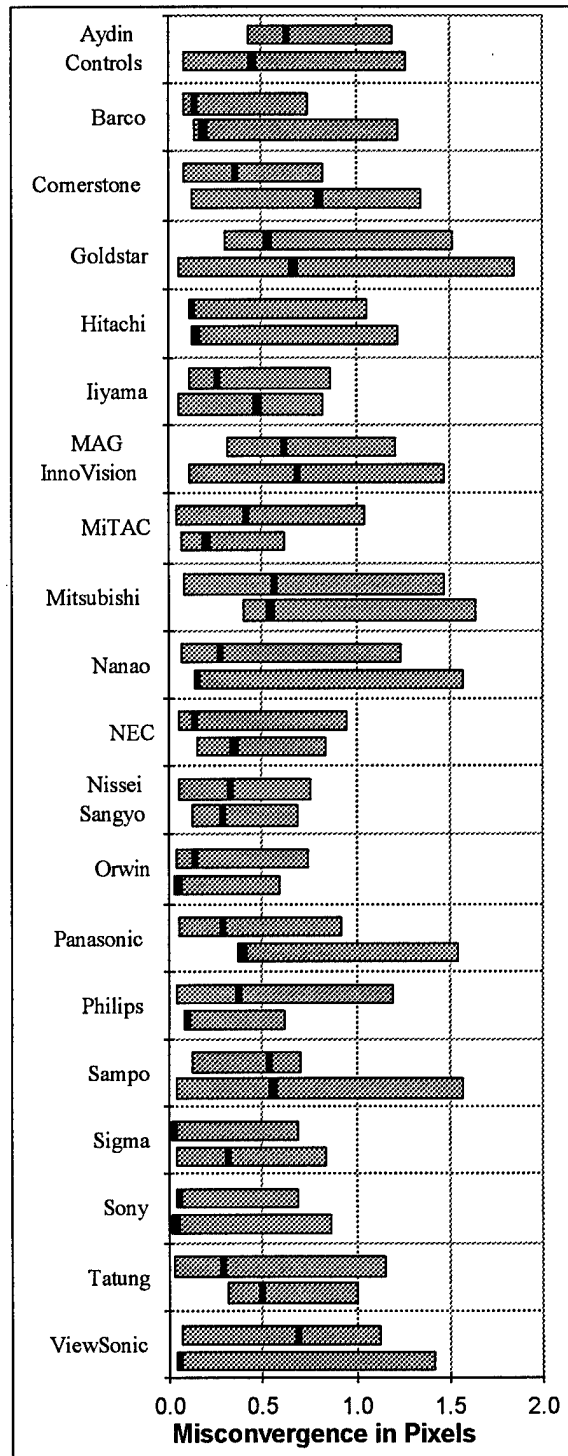

Figure 10. Comparison of misconvergence for the twenty monitors. For each monitor, the upper bar shows vertical misconvergence and the lower bar horizontal.

WAVINESS

The magnetic deflection system that moves the electron beam across the face of the tube does not produce perfectly straight lines. *Waviness* measures how much the display of a straight line varies from true straightness. This is sometimes called *geometric distortion*.

In the individual reports that follow we show the waviness of horizontally scanned lines at the top, center, and bottom of the display and for vertically scanned lines at the right side, center, and left side of the screen. In the comparison chart in Fig. 11, we show only the worst case waviness. A good display deviates from a straight line by less than 0.5% of the screen height.

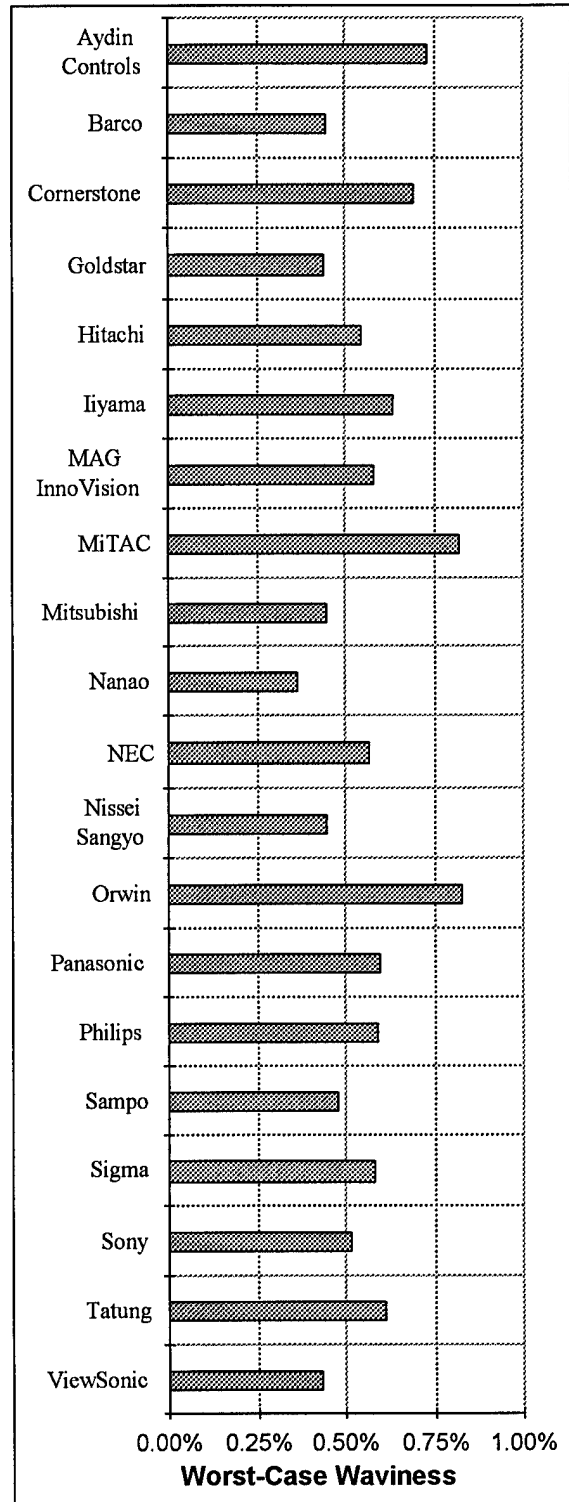

Figure 11. The length of the bar indicates worst-case waviness, or geometric distortion. Data for individual monitors in the next section show the actual form of the waviness.

THIS PAGE INTENTIONALLY LEFT BLANK

Individual Data on Each of Twenty Monitors

Aydin Controls 9010P
Barco CCID 121
Cornerstone Color 21/80
Goldstar 2010
Hitachi HM-6821-D
Iiyama MF-8221E
MAG InnoVision MX21F
MiTAC L2182
Mitsubishi Diamond Pro 21TX
Nanao FlexScan F780i•W
NEC MultiSync XP21
Nissei Sangyo SuperScan Supreme 21
Orwin C1632 (upgraded)
Panasonic Panasonic/Pro C-2192P
Philips 2130DC
Sampo AlphaScan GLX
Sigma ColorFX 21E
Sony Multiscan 20se
Tatung CM20MKR
ViewSonic 21PS

AYDIN CONTROLS 9010P

Manufacturer's Data

| | |
|--------------------------|-------------------------------------|
| Manufacturer Name | Aydin Controls |
| Model Number | 9010P |
| Price | \$2,300 |
| Screen Diagonal | 20 inches |
| Horizontal Scan Rate | 79.18 kHz |
| Vertical Scan Rate | 59.98 Hz |
| Image Size (H x V) | 14.9 x 10.9 inches |
| Addressable Pixel Number | 1600 x 1280 |
| Pixel Size | 9.30 x 8.52 mils (0.236 x 0.216 mm) |
| Dot Pitch | 11.0 mils (0.28 mm) |

Summary Comments:

- This monitor exhibited high waviness (0.73% of horizontal pincushion).
- Based on a $C_m = 25\%$, this monitor resolved 88% of the addressable pixels.

Detailed Performance Data

Display Resolution

| <u>Display Content</u> | <u>C_m Required</u> | <u>Resolution Limit</u> |
|------------------------|-------------------------------|-------------------------|
| Grayscale Imagery: | $C_m = 25\%$ | 1597 x 1133 |
| Text and Graphics | $C_m = 50\%$ | 1138 x 767 |

**Maximum Luminance
in Foot Lamberts**

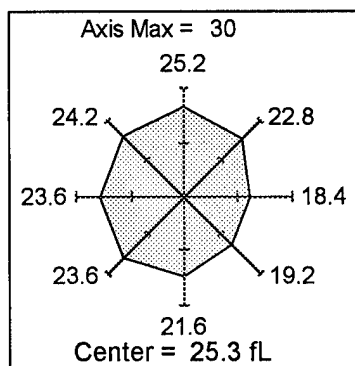

Linewidth in Pixels (RAR)

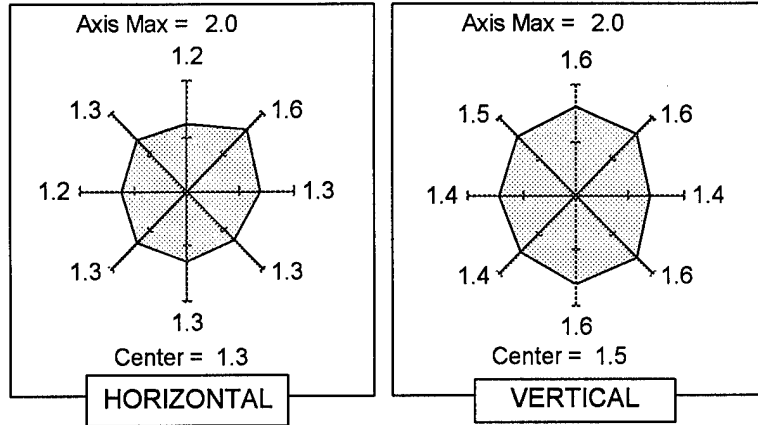

Contrast Modulation

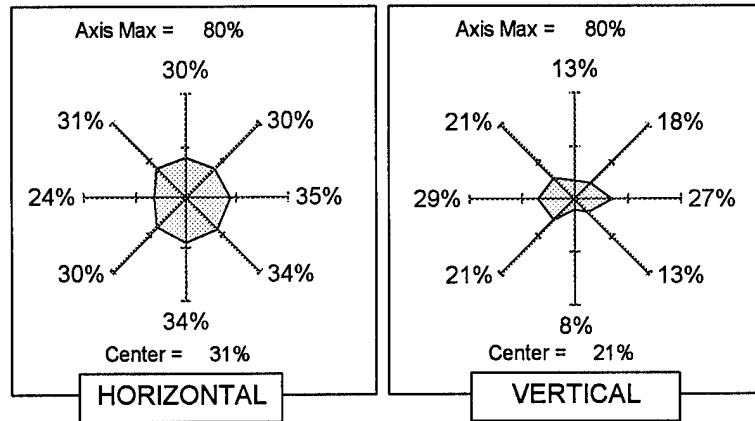

Misconvergence in Pixels

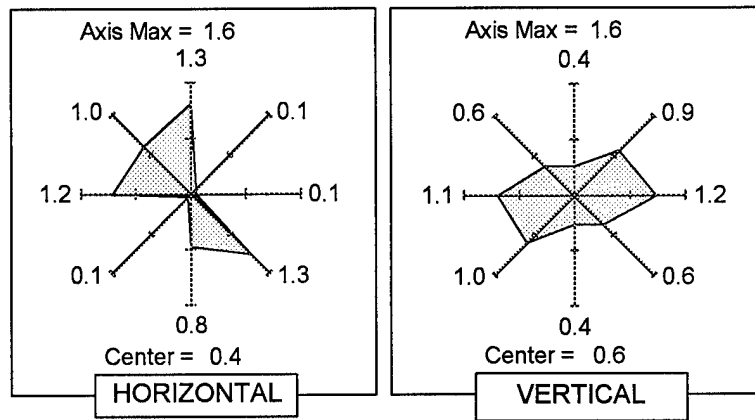

Waviness

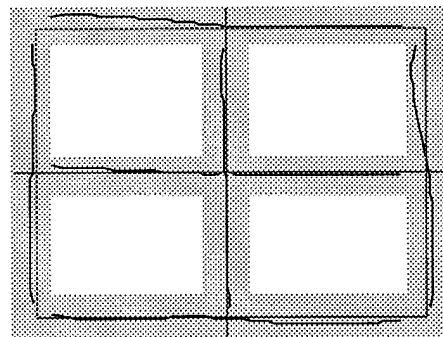

Gray band indicates ±1% distortion.

BARCO CCID 121

Manufacturer's Data

| | |
|--------------------------|-------------------------------------|
| Manufacturer Name | Barco |
| Model Number | CCID 121 |
| Price | \$6,000 |
| Screen Diagonal | 21 inches |
| Horizontal Scan Rate | 74.98 kHz |
| Vertical Scan Rate | 60.03 Hz |
| Image Size (H x V) | 14.7 x 11.0 inches |
| Addressable Pixel Number | 1600 x 1200 |
| Pixel Size | 9.18 x 9.19 mils (0.233 x 0.233 mm) |
| Dot Pitch | 11.0 mils (0.28 mm) |

Summary Comments:

- This monitor is referred to as the 'The Reference Calibrator'. It employs an automatic feedback circuit that maintains the luminance level and color balance, a feature not in the other monitors tested. This feature contributes to the cost of this monitor, one of the highest in the survey (\$6,000).
- Based on a $C_m = 25\%$, this monitor resolved 94% of the addressable pixels.

Detailed Performance Data

Display Resolution

| <u>Display Content</u> | <u>C_m Required</u> | <u>Resolution Limit</u> |
|------------------------|-------------------------------|-------------------------|
| Grayscale Imagery: | $C_m = 25\%$ | 1576 x 1149 |
| Text and Graphics | $C_m = 50\%$ | 1171 x 847 |

Maximum Luminance
in Foot Lamberts

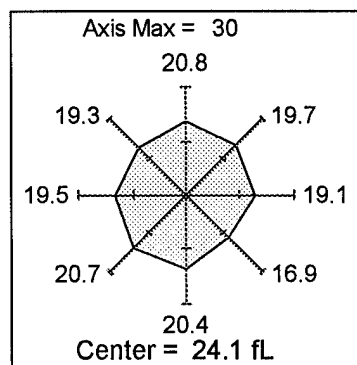

Linewidth in Pixels (RAR)

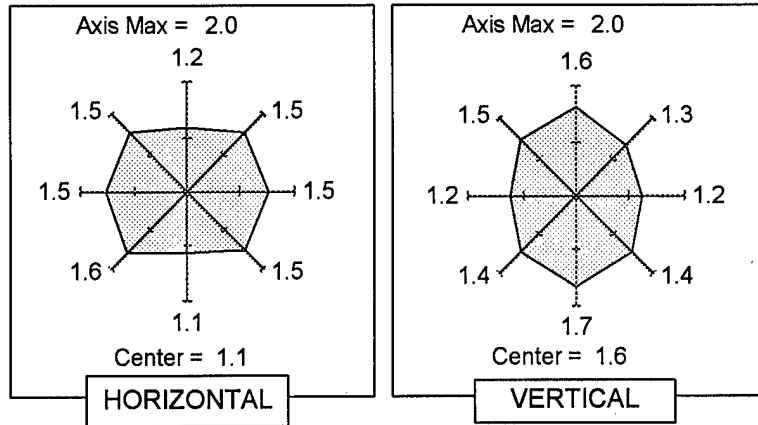

Contrast Modulation

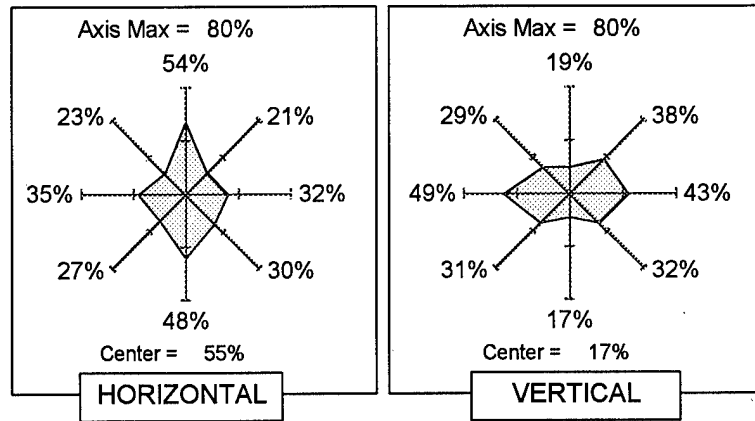

Misconvergence in Pixels

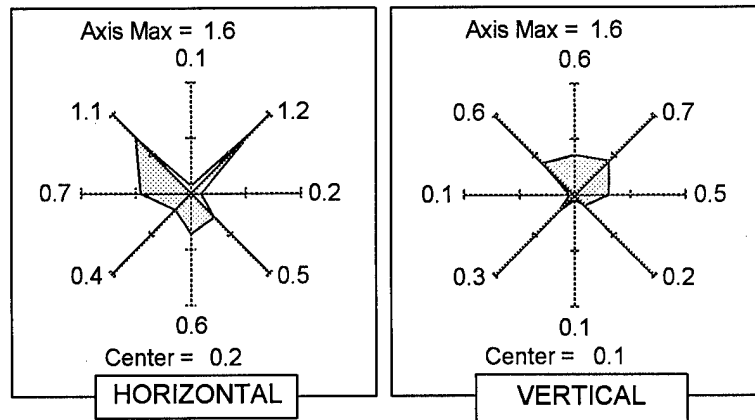

Waviness

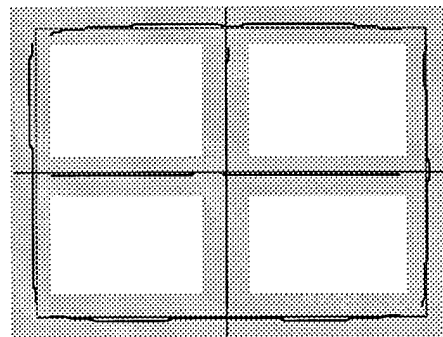

Gray band indicates ±1% distortion.

CORNERSTONE COLOR 21/80

Manufacturer's Data

| | |
|--------------------------|-------------------------------------|
| Manufacturer Name | Cornerstone |
| Model Number | Color 21/80 |
| Price | \$2,622 |
| Screen Diagonal | 21 inches |
| Horizontal Scan Rate | 106.65 kHz |
| Vertical Scan Rate | 80.31 Hz |
| Image Size (H x V) | 15.1 x 11.5 inches |
| Addressable Pixel Number | 1600 x 1280 |
| Pixel Size | 9.46 x 8.99 mils (0.240 x 0.228 mm) |
| Dot Pitch | 11.0 mils (0.28 mm) |

Summary Comments:

- The screen center luminance of 30.1 fL is one of the highest tested.
- The vertical Cm is degraded by Moiré and high RAR values at some screen edges.
- The 80 Hz refresh rate was among the highest tested.
- Based on a Cm = 25%, this monitor resolved 78% of the addressable pixels.

Detailed Performance Data

Display Resolution

| <u>Display Content</u> | <u>Cm Required</u> | <u>Resolution Limit</u> |
|------------------------|--------------------|-------------------------|
| Grayscale Imagery: | Cm = 25% | 1440 x 1109 |
| Text and Graphics | Cm = 50% | 1014 x 852 |

Maximum Luminance
in Foot Lamberts

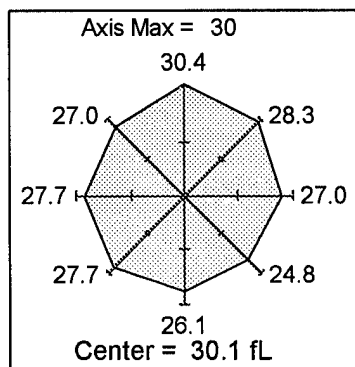

Linewidth in Pixels (RAR)

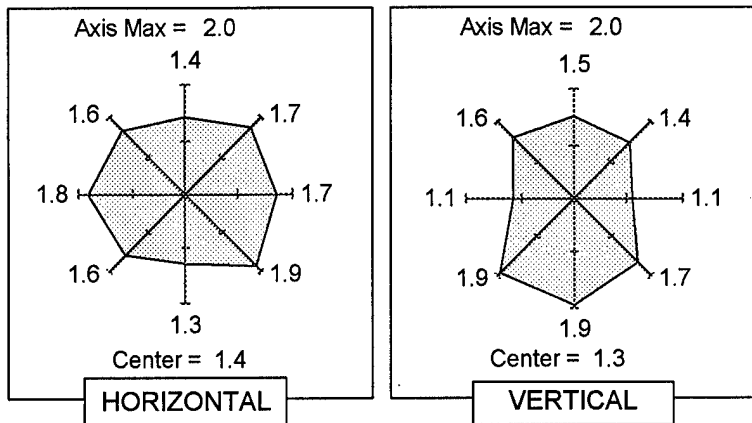

Contrast Modulation

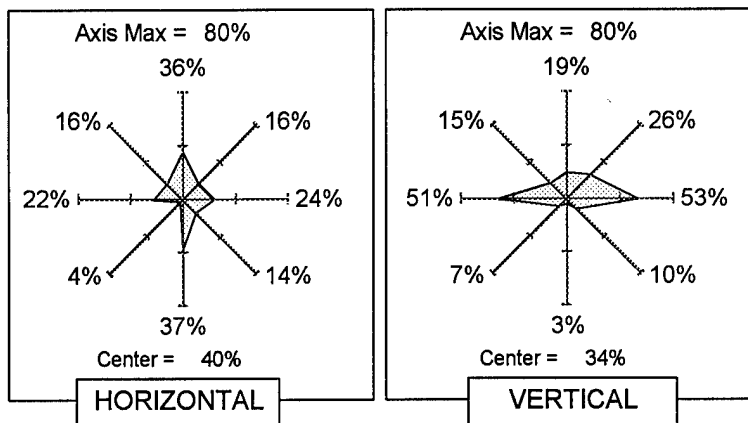

Misconvergence in Pixels

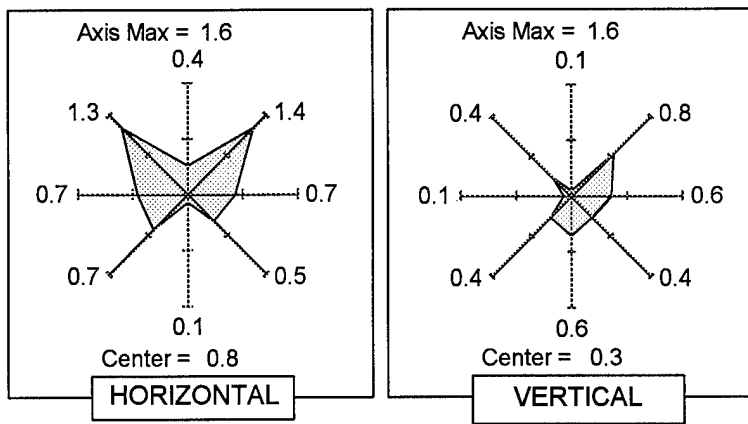

Waviness

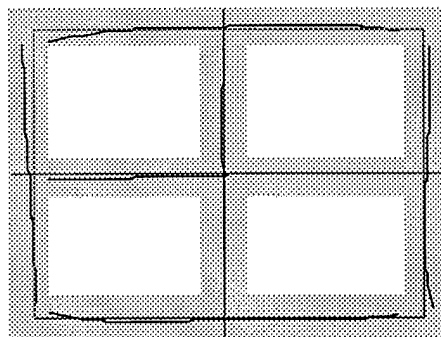

Gray band indicates ±1% distortion.

GOLDSTAR 2010

Manufacturer's Data

| | |
|--------------------------|-------------------------------------|
| Manufacturer Name | Goldstar |
| Model Number | 2010 |
| Price | \$1,430 |
| Screen Diagonal | 20 inches |
| Horizontal Scan Rate | 81.25 kHz |
| Vertical Scan Rate | 65.00 Hz |
| Image Size (H x V) | 14.4 x 10.6 inches |
| Addressable Pixel Number | 1600 x 1200 |
| Pixel Size | 9.00 x 8.83 mils (0.229 x 0.224 mm) |
| Dot Pitch | 11.0 mils (0.28 mm) |

Summary Comments:

- This is one of the lowest-cost monitors in the survey (\$1,430), but its performance was about average.
- Misconvergence exceeded 1.5 pixels at several places on the screen.
- Based on a $C_m = 25\%$, this monitor resolved 96% of the addressable pixels.

Detailed Performance Data

Display Resolution

| <u>Display Content</u> | <u>C_m Required</u> | <u>Resolution Limit</u> |
|------------------------|-------------------------------|-------------------------|
| Grayscale Imagery: | $C_m = 25\%$ | 1554 x 1191 |
| Text and Graphics | $C_m = 50\%$ | 1075 x 862 |

**Maximum Luminance
in Foot Lamberts**

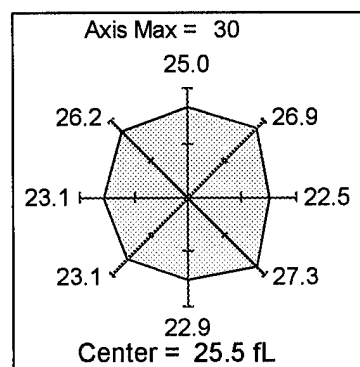

Linewidth in Pixels (RAR)

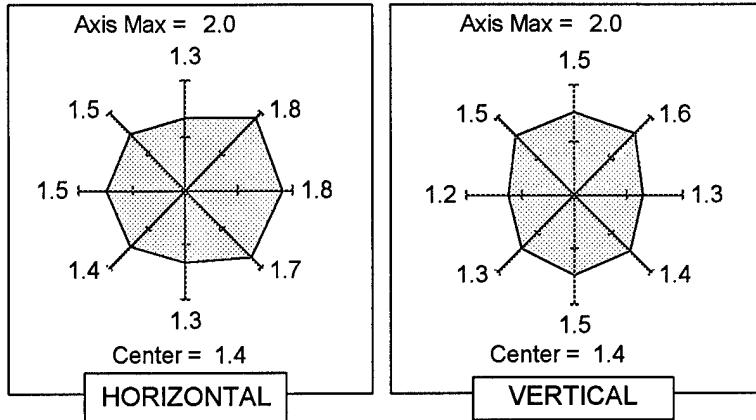

Contrast Modulation

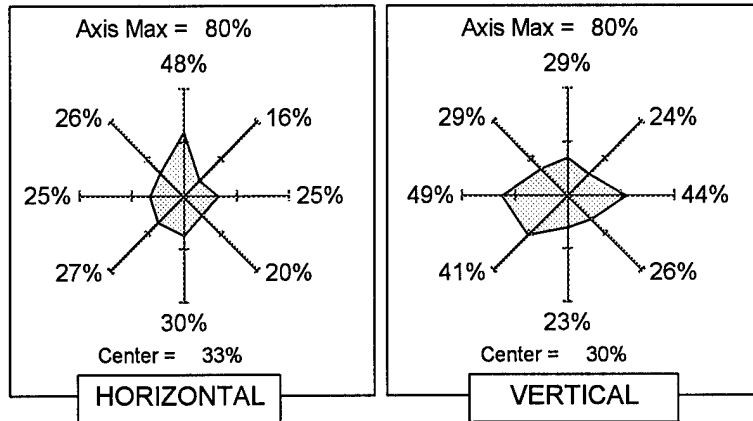

Misconvergence in Pixels

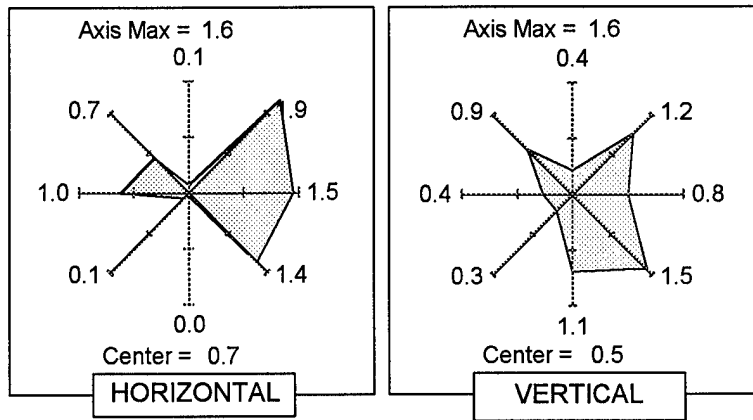

Waviness

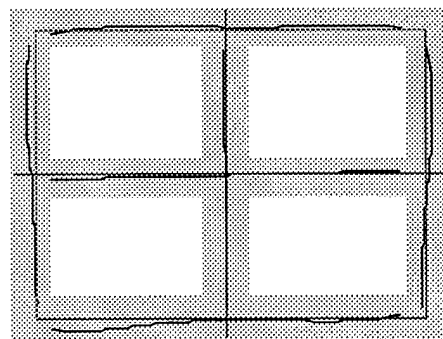

Gray band indicates $\pm 1\%$ distortion.

HITACHI HM-6821-D

Manufacturer's Data

| | |
|--------------------------|-------------------------------------|
| Manufacturer Name | Hitachi |
| Model Number | HM-6821-D |
| Price | \$2,650 |
| Screen Diagonal | 21 inches |
| Horizontal Scan Rate | 106.08 kHz |
| Vertical Scan Rate | 80.00 Hz |
| Image Size (H x V) | 15.0 x 11.2 inches |
| Addressable Pixel Number | 1600 x 1280 |
| Pixel Size | 9.35 x 8.76 mils (0.237 x 0.223 mm) |
| Dot Pitch | 0.22 mm horizontal/0.16 mm vertical |

Summary Comments:

- The CRT features an UltraFine dot pitch (0.22 mm horizontal/0.16 mm vertical).
- The 80 Hz refresh rate was among the highest tested.
- Based on a $C_m = 25\%$, this monitor resolved all of the addressable pixels.

Detailed Performance Data

Display Resolution

| <u>Display Content</u> | <u>C_m Required</u> | <u>Resolution Limit</u> |
|------------------------|-------------------------------|-------------------------|
| Grayscale Imagery: | $C_m = 25\%$ | 1600 x 1280 |
| Text and Graphics | $C_m = 50\%$ | 1270 x 941 |

**Maximum Luminance
in Foot Lamberts**

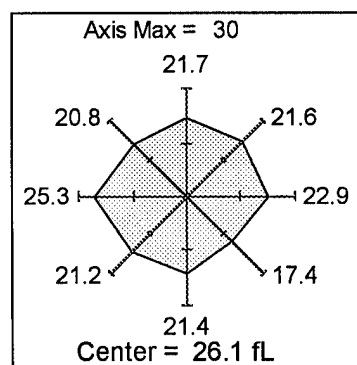

Linewidth in Pixels (RAR)

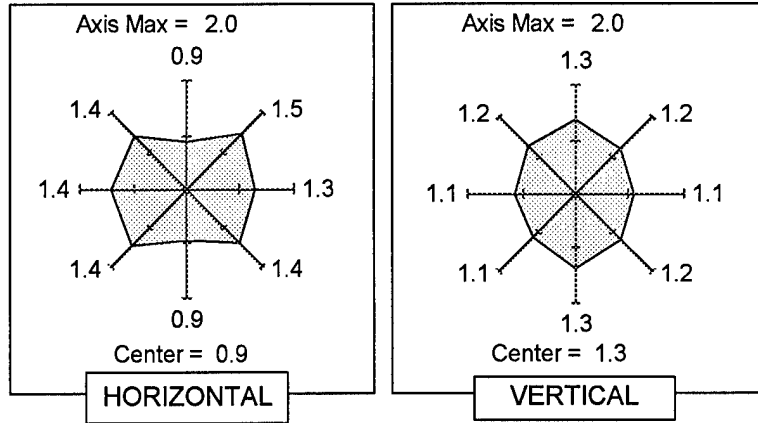

Contrast Modulation

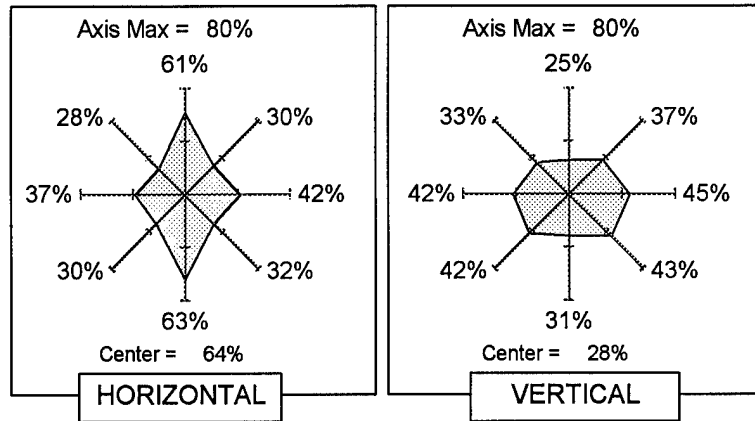

Misconvergence in Pixels

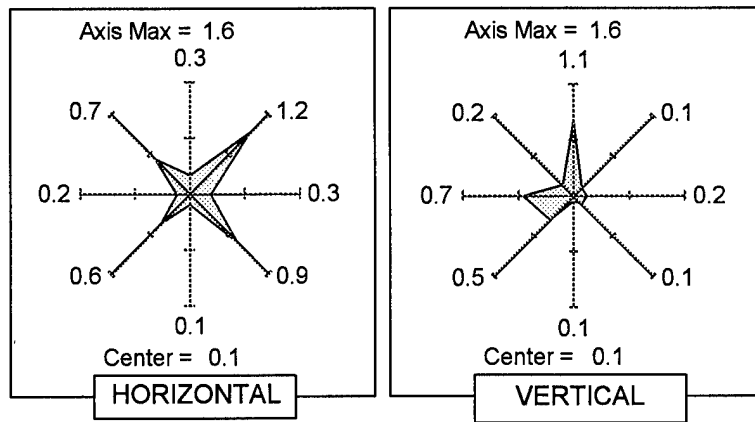

Waviness

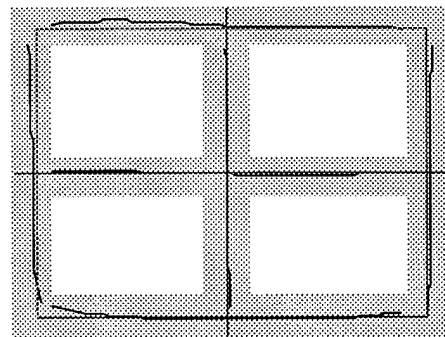

Gray band indicates $\pm 1\%$ distortion.

IYAMA MF-8221E

Manufacturer's Data

| | |
|--------------------------|-------------------------------------|
| Manufacturer Name | Iiyama |
| Model Number | MF-8221E |
| Price | \$2,049 |
| Screen Diagonal | 21 inches |
| Horizontal Scan Rate | 93.75 kHz |
| Vertical Scan Rate | 75.00 Hz |
| Image Size (H x V) | 15.0 x 11.2 inches |
| Addressable Pixel Number | 1600 x 1200 |
| Pixel Size | 9.35 x 9.34 mils (0.237 x 0.237 mm) |
| Dot Pitch | 11.0 mils (0.28 mm) |

Summary Comments:

- Vertical Cm is among the best tested. Horizontal Cm was degraded by the presence of Moiré on 1-on/1-off vertical grille patterns.
- Moiré correction circuitry available on this monitor was not evaluated and was instead set to the OFF position during testing.
- Based on a Cm =25% this monitor resolved 96% of the addressable pixels.

Detailed Performance Data

Display Resolution

| <u>Display Content</u> | <u>Cm Required</u> | <u>Resolution Limit</u> |
|------------------------|--------------------|-------------------------|
| Grayscale Imagery: | Cm = 25% | 1539 x 1200 |
| Text and Graphics | Cm = 50% | 1063 x 1108 |

**Maximum Luminance
in Foot Lamberts**

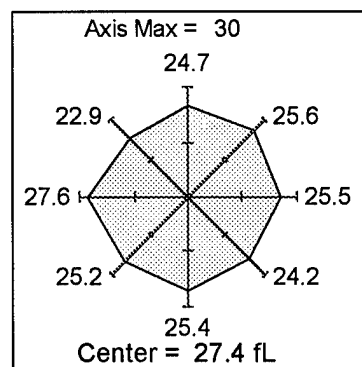

Linewidth in Pixels (RAR)

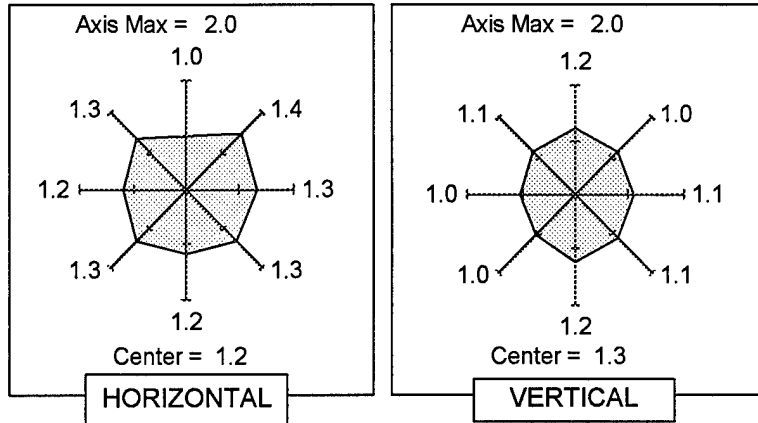

Contrast Modulation

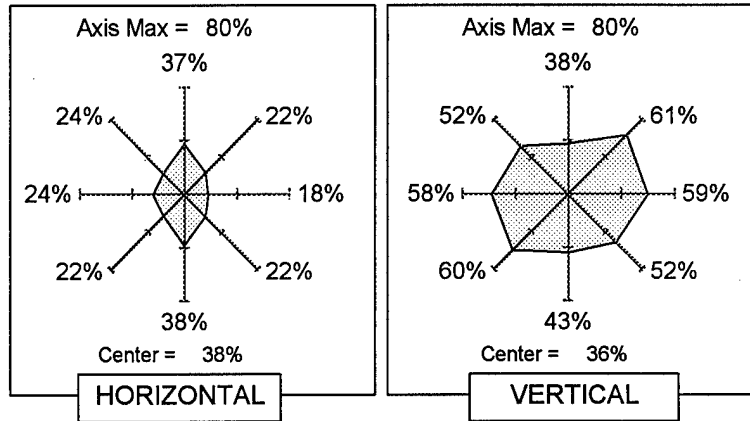

Misconvergence in Pixels

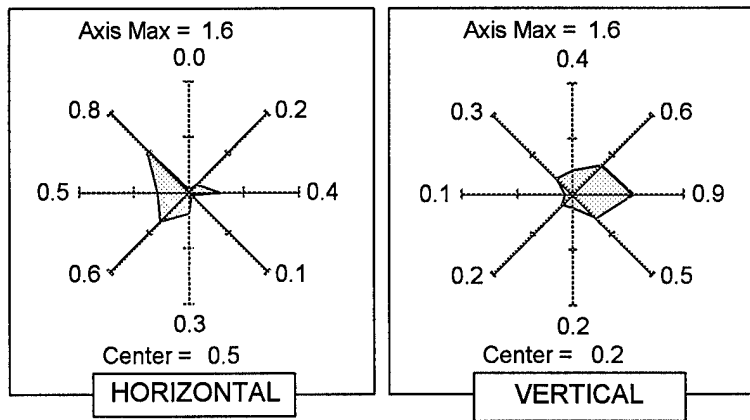

Waviness

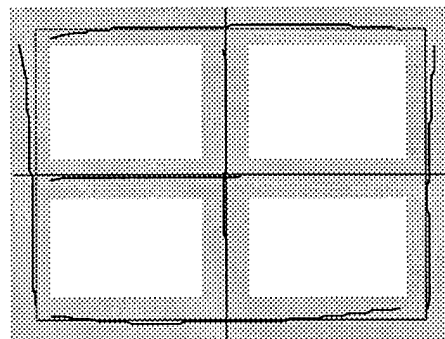

Gray band indicates $\pm 1\%$ distortion.

MAG INNOVISION MX21F

Manufacturer's Data

| | |
|--------------------------|-------------------------------------|
| Manufacturer Name | MAG InnoVision |
| Model Number | MX21F |
| Price | \$1,971 |
| Screen Diagonal | 21 inches |
| Horizontal Scan Rate | 75.00 kHz |
| Vertical Scan Rate | 60.00 Hz |
| Image Size (H x V) | 15.0 x 11.2 inches |
| Addressable Pixel Number | 1600 x 1200 |
| Pixel Size | 9.36 x 9.35 mils (0.238 x 0.237 mm) |
| Dot Pitch | 11.0 mils (0.28 mm) |

Summary Comments:

- The luminance was the lowest in this survey, less than 21 fL everywhere.
- Horizontal Cm was degraded by the presence of Moiré on vertical grille patterns.
- Based on a Cm = 25%, this monitor resolved 84% of the addressable pixels.
- The original purchase price to NIDL for this monitor was \$1,971. The manufacturer now offers this monitor at a suggested retail of \$1,799.

Detailed Performance Data

Display Resolution

| <u>Display Content</u> | <u>Cm Required</u> | <u>Resolution Limit</u> |
|------------------------|--------------------|-------------------------|
| Grayscale Imagery: | Cm = 25% | 1461 x 1110 |
| Text and Graphics | Cm = 50% | 1017 x 770 |

**Maximum Luminance
in Foot Lamberts**

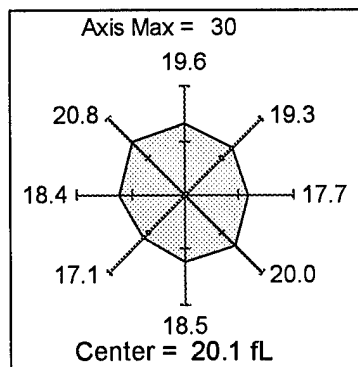

Linewidth in Pixels (RAR)

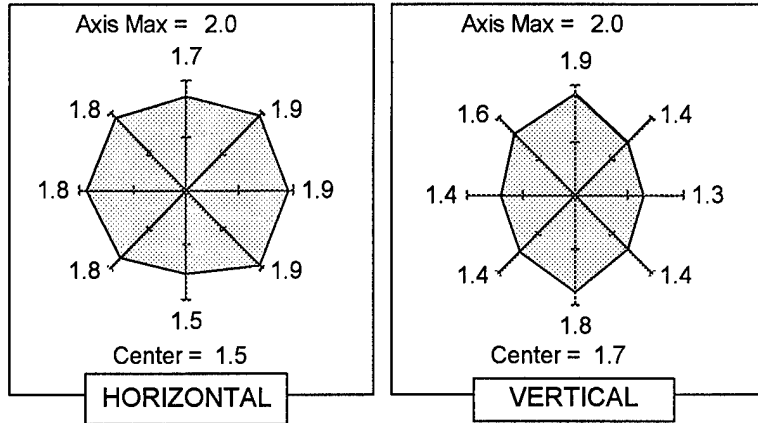

Contrast Modulation

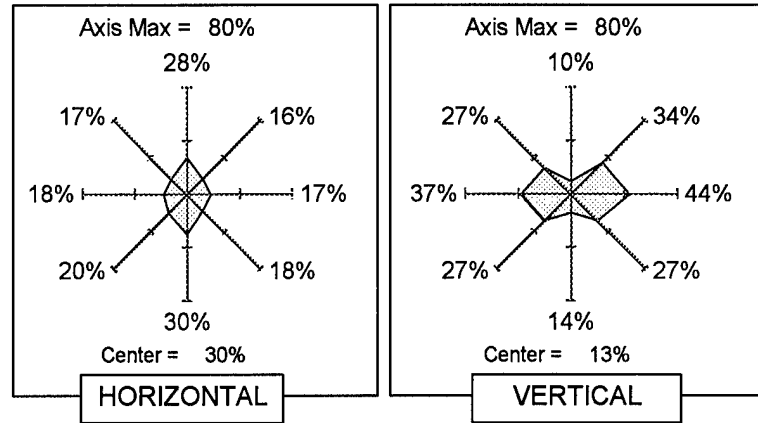

Misconvergence in Pixels

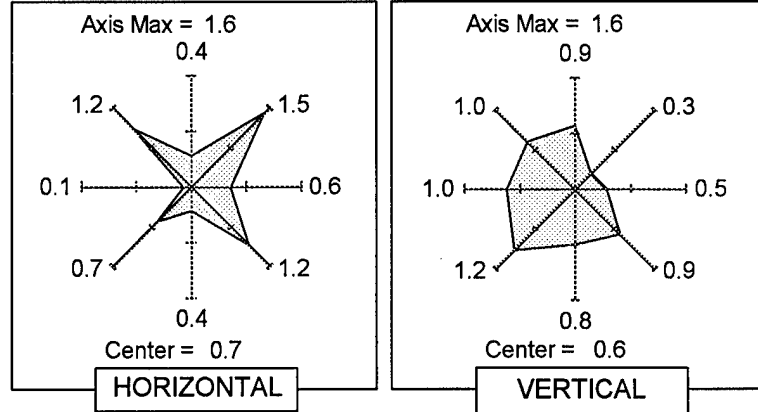

Waviness

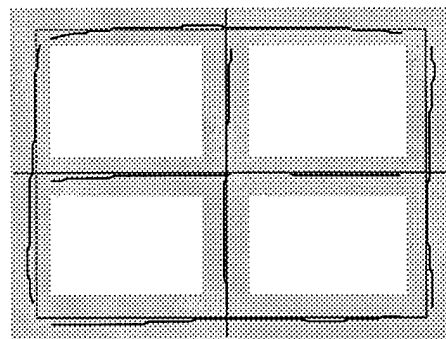

Gray band indicates ±1% distortion.

MiTAC L2182

Manufacturer's Data

| | |
|--------------------------|-------------------------------------|
| Manufacturer Name | MiTAC |
| Model Number | L2182 |
| Price | \$2,070 |
| Screen Diagonal | 21 inches |
| Horizontal Scan Rate | 82.01 kHz |
| Vertical Scan Rate | 62.08 Hz |
| Image Size (H x V) | 15.0 x 11.2 inches |
| Addressable Pixel Number | 1600 x 1280 |
| Pixel Size | 9.34 x 8.76 mils (0.237 x 0.223 mm) |
| Dot Pitch | 9.8 mils (0.25 mm) |

Summary Comments:

- The monitor exhibited high waviness (geometric distortion); vertical pincushion was 0.82%.
- Based on a Cm = 25%, this monitor resolved 94% of the addressable pixels.
- Moiré correction circuitry available on this monitor was not evaluated and was instead set to the OFF position during testing.

Detailed Performance Data

Display Resolution

| <u>Display Content</u> | <u>Cm Required</u> | <u>Resolution Limit</u> |
|------------------------|--------------------|-------------------------|
| Grayscale Imagery: | Cm = 25% | 1513 x 1276 |
| Text and Graphics | Cm = 50% | 1024 x 945 |

**Maximum Luminance
in Foot Lamberts**

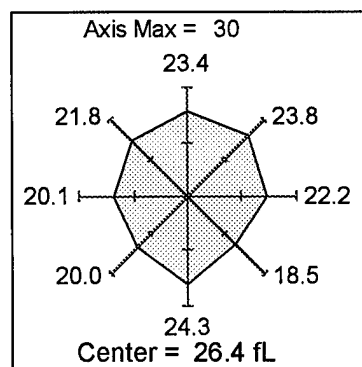

Linewidth in Pixels (RAR)

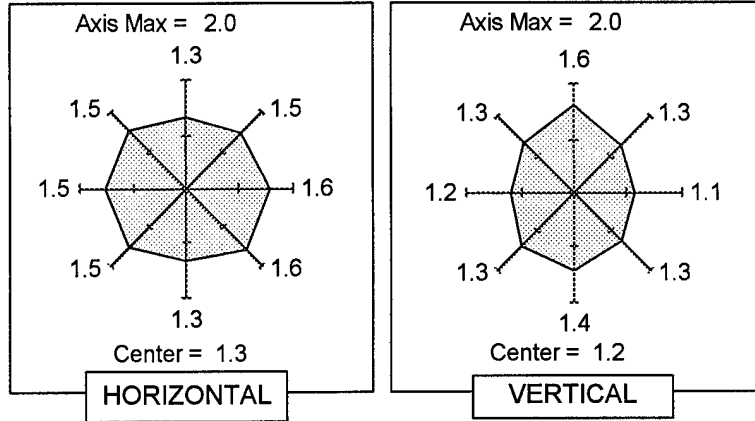

Contrast Modulation

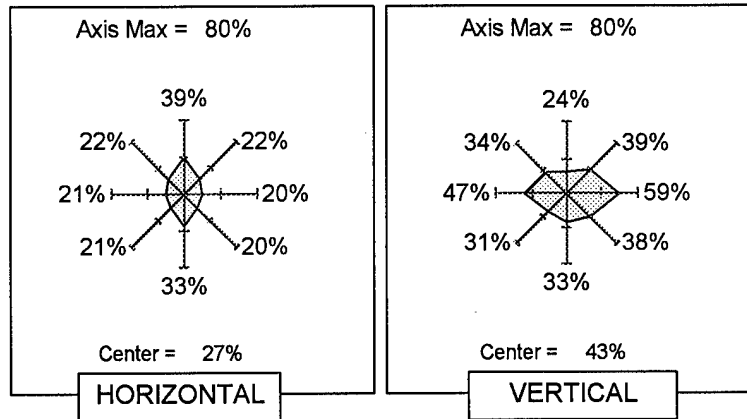

Misconvergence in Pixels

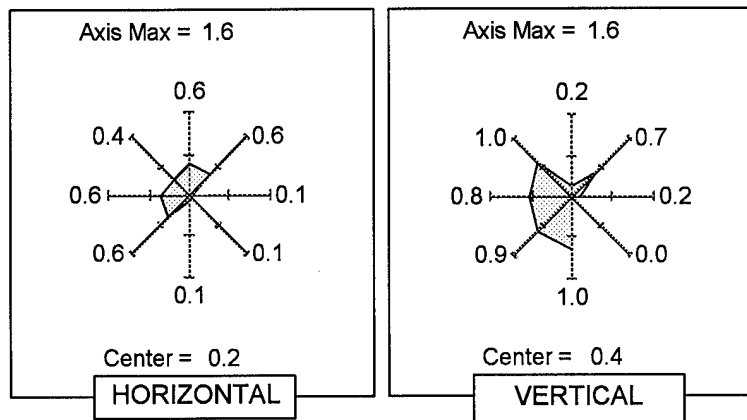

Waviness

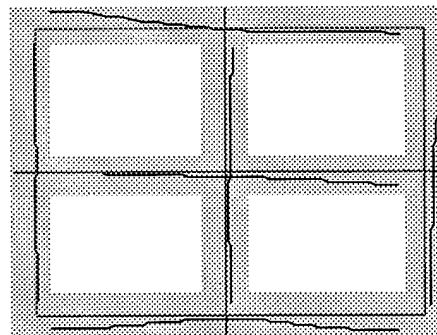

Gray band indicates $\pm 1\%$ distortion.

MITSUBISHI DIAMOND PRO 21TX

Manufacturer's Data

| | |
|--------------------------|-------------------------------------|
| Manufacturer Name | Mitsubishi |
| Model Number | Diamond Pro 21TX |
| Price | \$2,100 |
| Screen Diagonal | 21 inches |
| Horizontal Scan Rate | 92.77 kHz |
| Vertical Scan Rate | 75.00 Hz |
| Image Size (H x V) | 15.0 x 11.2 inches |
| Addressable Pixel Number | 1600 x 1200 |
| Pixel Size | 9.36 x 9.32 mils (0.238 x 0.237 mm) |
| Stripe Pitch | 11.8 mils (0.30 mm) |

Summary Comments:

- The monitor features the DIAMONDTRON aperture grille.
- Horizontal Cm was degraded by Moiré and varied significantly over the screen.
- The horizontal waviness was minimal (0.14% for horizontal pincushion).
- Based on a Cm = 25%, this monitor resolved 94% of the addressable pixels.
- Moiré correction circuitry available on this monitor was not evaluated and was instead set to the OFF position during testing.

Detailed Performance Data

Display Resolution

| <u>Display Content</u> | <u>Cm Required</u> | <u>Resolution Limit</u> |
|------------------------|--------------------|-------------------------|
| Grayscale Imagery: | Cm = 25% | 1506 x 1200 |
| Text and Graphics | Cm = 50% | 1145 x 1007 |

Linewidth in Pixels (RAR)

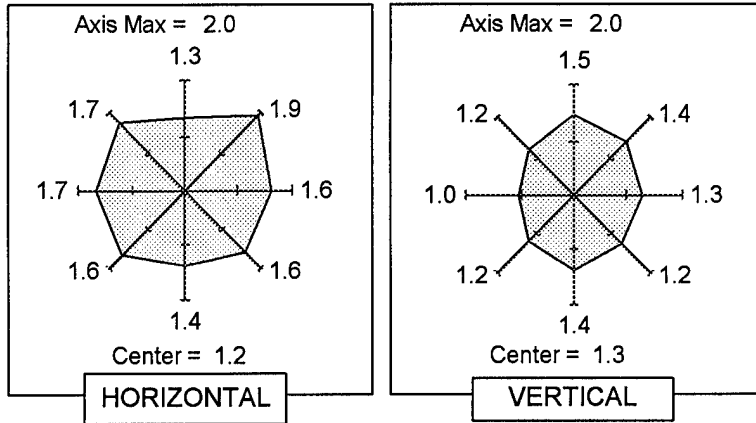

Contrast Modulation

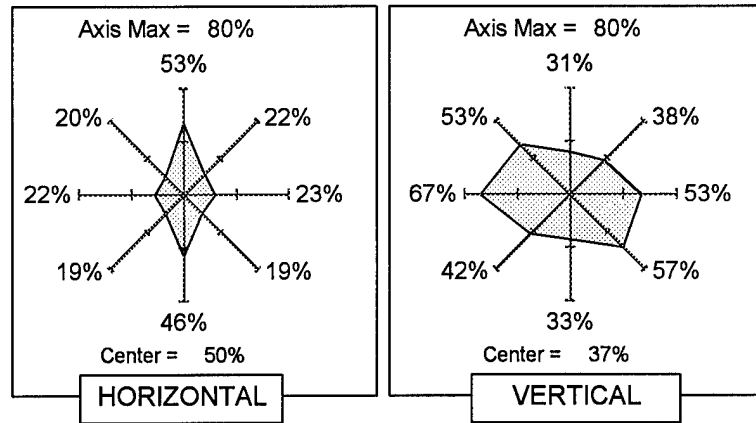

Misconvergence in Pixels

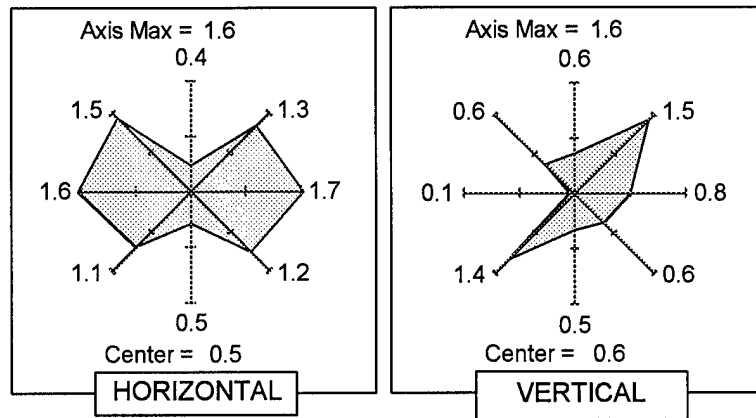

Maximum Luminance in Foot Lamberts

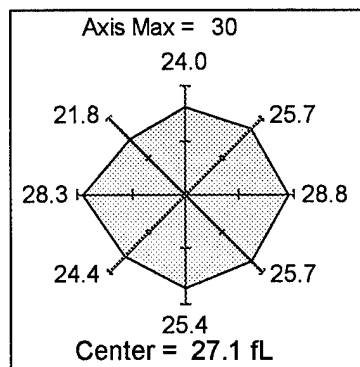

Waviness

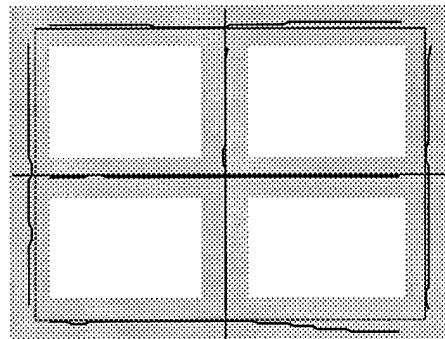

Gray band indicates $\pm 1\%$ distortion.

NANAO FLEXSCAN F780i•W**Manufacturer's Data**

| | |
|--------------------------|-------------------------------------|
| Manufacturer Name | Nanao |
| Model Number | FlexScan F780i•W |
| Price | \$3,300 |
| Screen Diagonal | 21 inches |
| Horizontal Scan Rate | 96.52 kHz |
| Vertical Scan Rate | 77.41 Hz |
| Image Size (H x V) | 15.0 x 11.2 inches |
| Addressable Pixel Number | 1600 x 1200 |
| Pixel Size | 9.35 x 9.35 mils (0.237 x 0.237 mm) |
| Dot Pitch | 10.2 mils (0.26 mm) |

Summary Comments:

- Screen center luminance was one of the lowest in this survey (21.9 fL).
- The monitor showed high horizontal Cm.
- Based on a Cm = 25%, this monitor resolved 96% of the addressable pixels.

Detailed Performance Data**Display Resolution**

| <u>Display Content</u> | <u>Cm Required</u> | <u>Resolution Limit</u> |
|------------------------|--------------------|-------------------------|
| Grayscale Imagery: | Cm = 25% | 1600 x 1151 |
| Text and Graphics | Cm = 50% | 1417 x 821 |

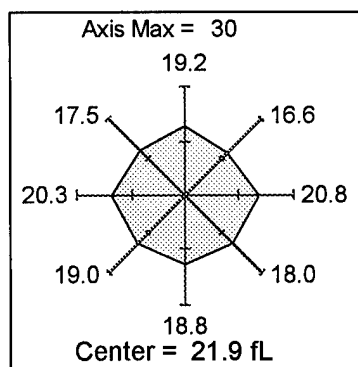
**Maximum Luminance
in Foot Lamberts**

Linewidth in Pixels (RAR)

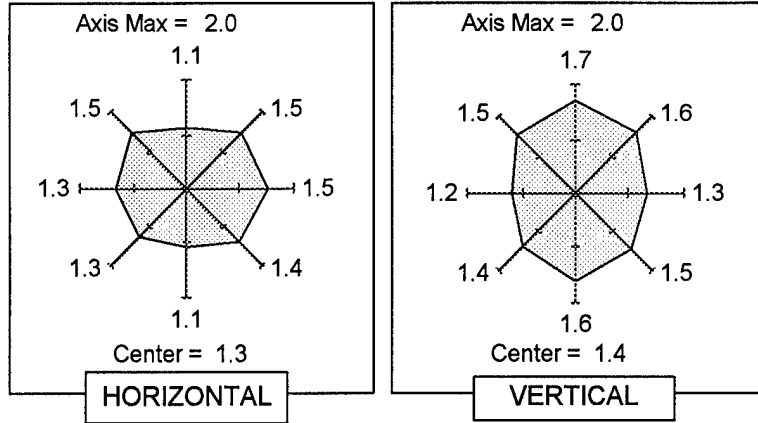

Contrast Modulation

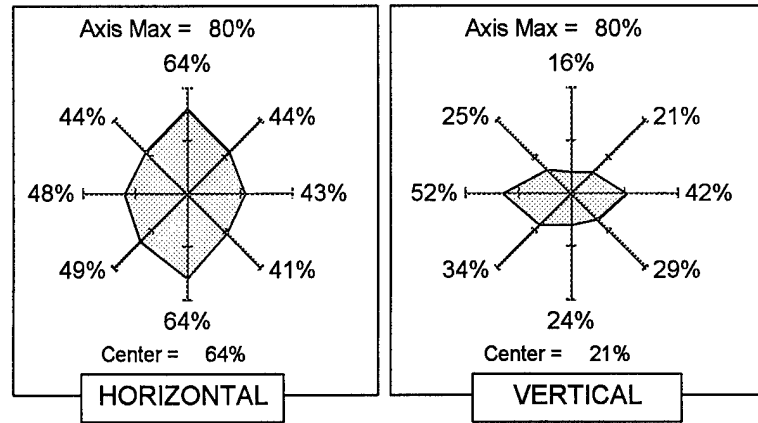

Misconvergence in Pixels

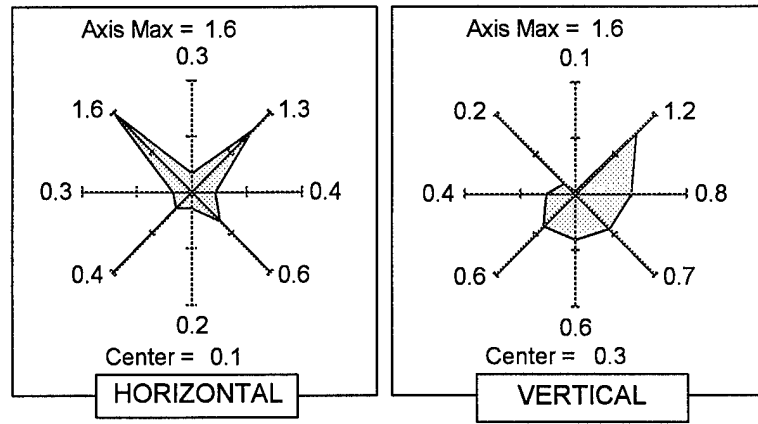

Waviness

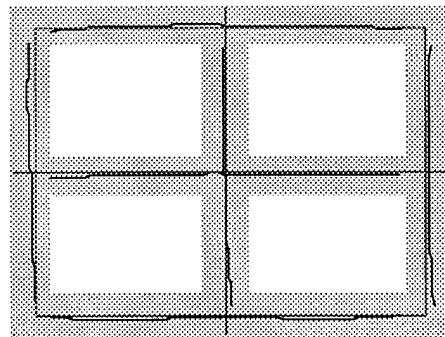

Gray band indicates ±1% distortion.

NEC MULTISYNC XP21

Manufacturer's Data

| | |
|--------------------------|-------------------------------------|
| Manufacturer Name | NEC |
| Model Number | MultiSync XP21 |
| Price | \$2,245 |
| Screen Diagonal | 21 inches |
| Horizontal Scan Rate | 87.50 kHz |
| Vertical Scan Rate | 70.00 Hz |
| Image Size (H x V) | 14.8 x 11.1 inches |
| Addressable Pixel Number | 1600 x 1200 |
| Pixel Size | 9.26 x 9.26 mils (0.235 x 0.235 mm) |
| Dot Pitch | 11.0 mils (0.28 mm) |

Summary Comments:

- Contrast modulation and resolution limit are among the best tested.
- Based on a $C_m = 25\%$, this monitor resolved all of the addressable pixels.

Detailed Performance Data

Display Resolution

| <u>Display Content</u> | <u>C_m Required</u> | <u>Resolution Limit</u> |
|------------------------|-------------------------------|-------------------------|
| Grayscale Imagery: | $C_m = 25\%$ | 1600 x 1200 |
| Text and Graphics | $C_m = 50\%$ | 1245 x 1117 |

Maximum Luminance in Foot Lamberts

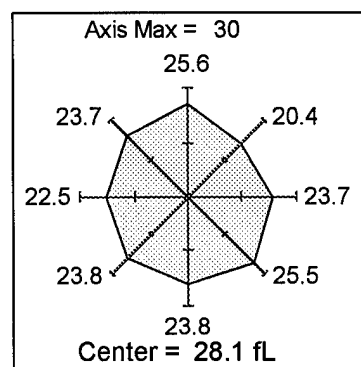

Linewidth in Pixels (RAR)

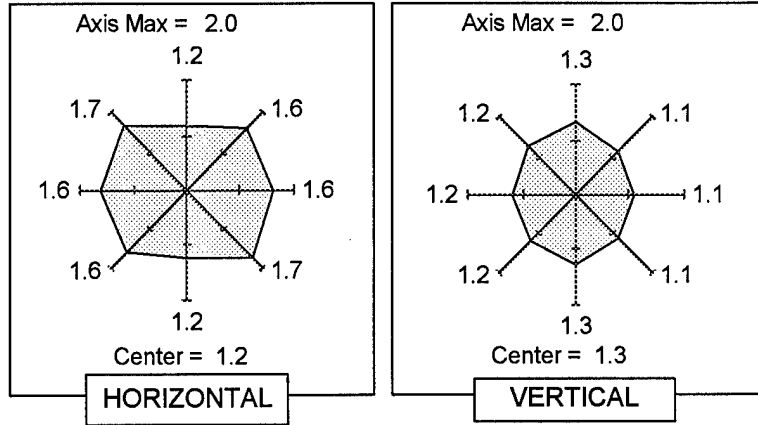

Contrast Modulation

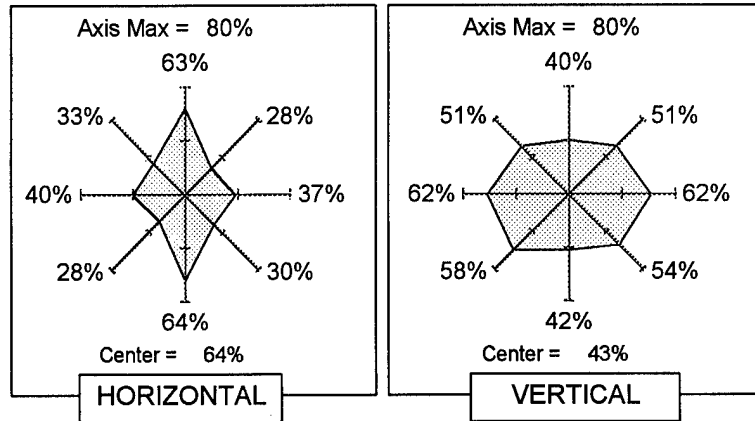

Misconvergence in Pixels

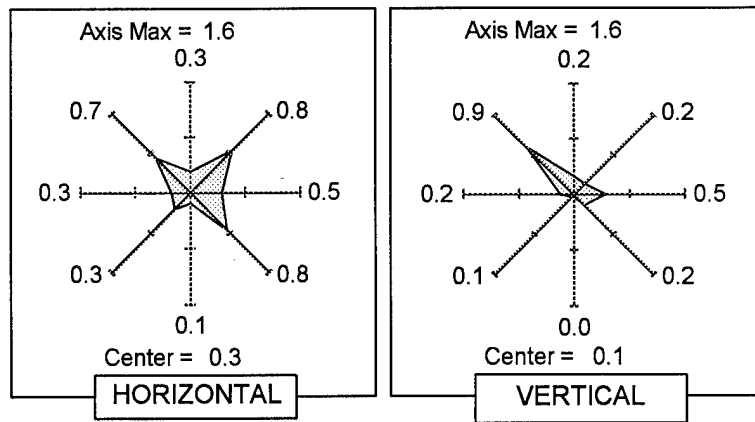

Waviness

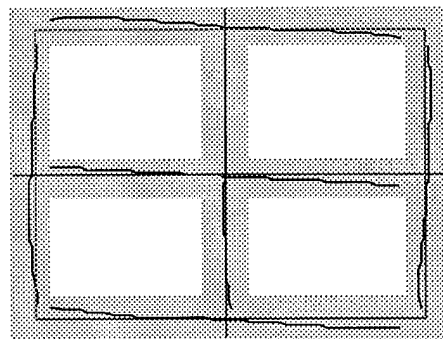

Gray band indicates ±1% distortion.

NISSEI SANGYO SUPERSCAN SUPREME 21**Manufacturer's Data**

| | |
|--------------------------|--|
| Manufacturer Name | Nissei Sangyo (also known as NSA Hitachi) |
| Model Number | SuperScan Supreme 21 |
| Price | \$2,895 |
| Screen Diagonal | 21 inches |
| Horizontal Scan Rate | 106.25 kHz |
| Vertical Scan Rate | 85.00 Hz |
| Image Size (H x V) | 15.6 x 11.6 inches |
| Addressable Pixel Number | 1600 x 1200 |
| Pixel Size | 9.72 x 9.68 mils (0.247 x 0.246 mm) |
| Dot Pitch | 10.2 mils (0.26 mm) |

Summary Comments:

- The screen center luminance of 30.1 fL is one of the highest tested.
- The monitor showed low waviness (0.25% for vertical pincushion).
- The 85 Hz refresh rate was among the highest tested.
- Based on a $C_m = 25\%$, this monitor resolved 76% of the addressable pixels, the lowest value in the survey.
- Moiré correction circuitry available on this monitor was not evaluated and was instead set to the OFF position during testing.

Detailed Performance Data**Display Resolution**

| <u>Display Content</u> | <u>Cm Required</u> | <u>Resolution Limit</u> |
|------------------------|--------------------|-------------------------|
| Grayscale Imagery: | $C_m = 25\%$ | 1397 x 1045 |
| Text and Graphics | $C_m = 50\%$ | 985 x 748 |

Linewidth in Pixels (RAR)

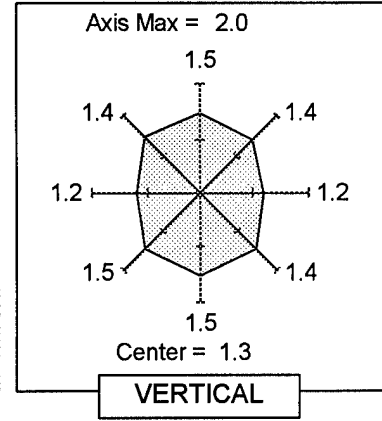
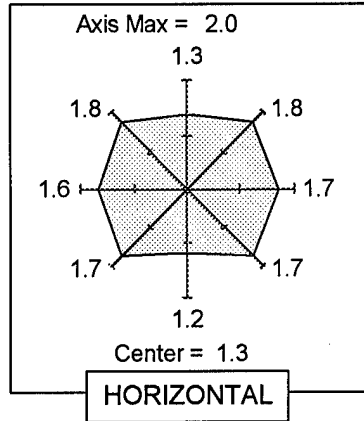

Contrast Modulation

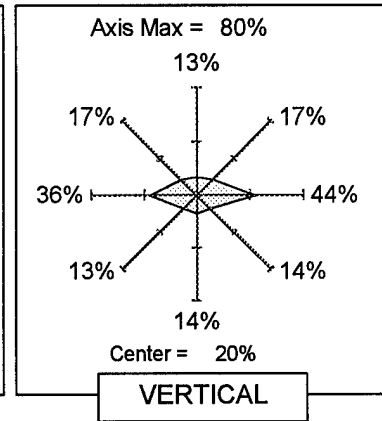
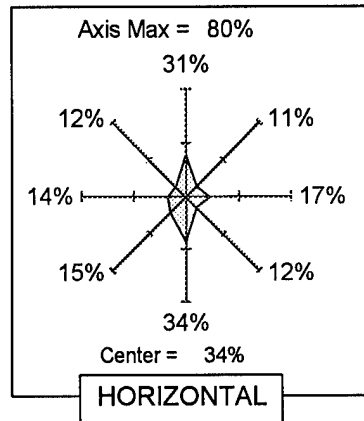

Misconvergence in Pixels

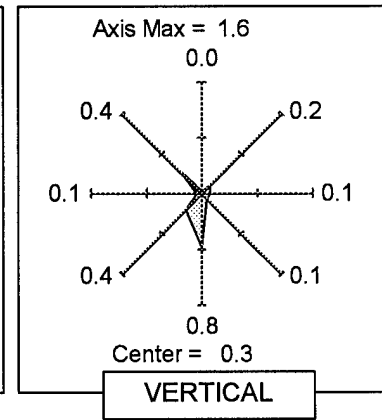
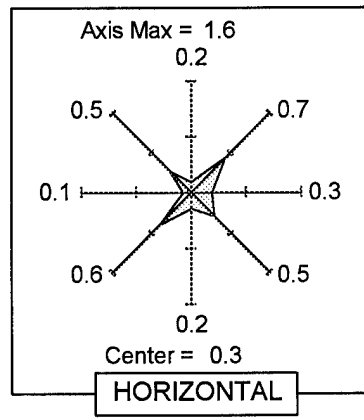

Maximum Luminance in Foot Lamberts

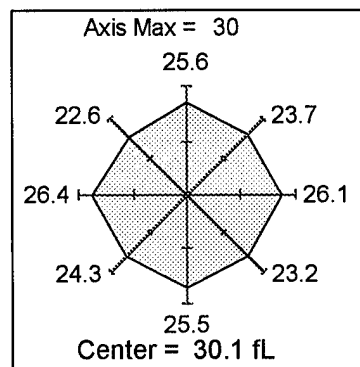

Waviness

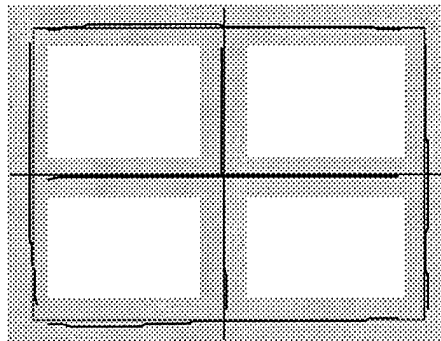

Gray band indicates $\pm 1\%$ distortion.

ORWIN C1632 (UPGRADED)**Manufacturer's Data**

| | |
|--------------------------|-------------------------------------|
| Manufacturer Name | Orwin |
| Model Number | C1632 (Upgraded) |
| Price | \$7,000 (Quantity pricing) |
| Screen Diagonal | 21 inches |
| Horizontal Scan Rate | 95.61 kHz |
| Vertical Scan Rate | 72.00 Hz |
| Image Size (H x V) | 14.9 x 11.6 inches |
| Addressable Pixel Number | 1600 x 1280 |
| Pixel Size | 9.30 x 9.06 mils (0.236 x 0.230 mm) |
| Dot Pitch | 10.2 mils (0.26 mm) |

Summary Comments:

- This was the only ruggedized monitor in the survey. That certainly contributes to the high cost, which should not be compared to the other, non-ruggedized monitors.
- The deflection system on this unit was upgraded by Orwin to achieve 1600 x 1280 addressable pixels, but resolution was still lower than 1600 x 1280.
- The video amplifier in this monitor is intended for 1280 x 1024 addressable pixels and may not have sufficient bandwidth to support 1600 x 1280 format. The manufacturer offers an optional higher bandwidth video amplifier intended for 1600 x 1280 applications.
- Horizontal Cm was degraded by Moiré on vertical grille patterns.
- The monitor exhibited high waviness of 0.83% for vertical pincushion.
- Based on a Cm = 25%, this monitor resolved 81% of the addressable pixels.

Detailed Performance Data**Display Resolution**

| <u>Display Content</u> | <u>Cm Required</u> | <u>Resolution Limit</u> |
|------------------------|--------------------|-------------------------|
| Grayscale Imagery: | Cm = 25% | 1380 x 1198 |
| Text and Graphics | Cm = 50% | 950 x 852 |

Linewidth in Pixels (RAR)

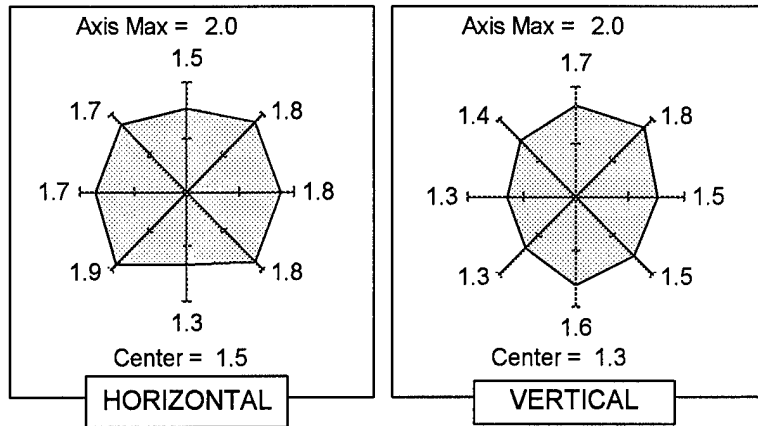

Contrast Modulation

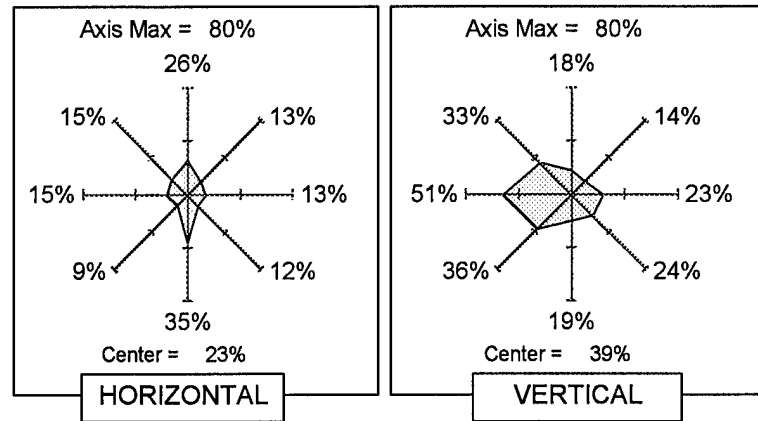

Misconvergence in Pixels

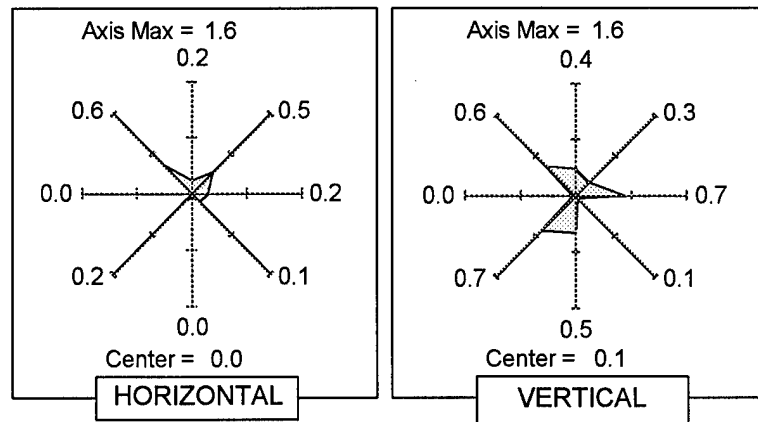

Maximum Luminance in Foot Lamberts

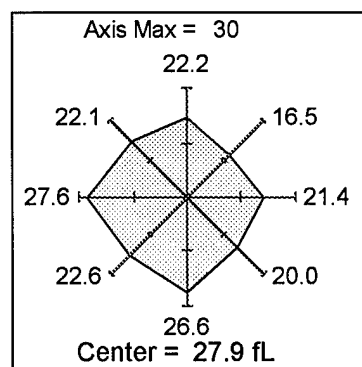

Waviness

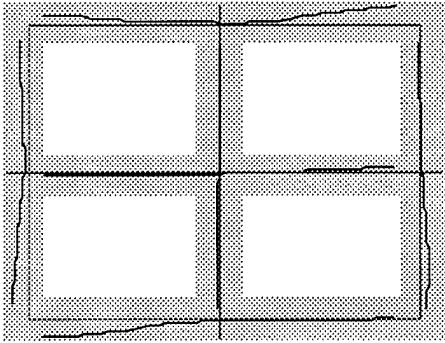

Gray band indicates $\pm 1\%$ distortion.

PANASONIC PANASONIC/PRO C-2192P**Manufacturer's Data**

| | |
|--------------------------|-------------------------------------|
| Manufacturer Name | Panasonic |
| Model Number | Panasonic/Pro C-2192P |
| Price | \$1,848 |
| Screen Diagonal | 21 inches |
| Horizontal Scan Rate | 82.01 kHz |
| Vertical Scan Rate | 62.08 Hz |
| Image Size (H x V) | 15.0 x 11.2 inches |
| Addressable Pixel Number | 1600 x 1280 |
| Pixel Size | 9.37 x 8.78 mils (0.238 x 0.223 mm) |
| Dot Pitch | 9.8 mils (0.25 mm) |

Summary Comments:

- Based on a $C_m = 25\%$, this monitor resolved 92% of the addressable pixels.
- Moiré correction circuitry available on this monitor was not evaluated and was instead set to the OFF position during testing.

Detailed Performance Data**Display Resolution**

| <u>Display Content</u> | <u>C_m Required</u> | <u>Resolution Limit</u> |
|------------------------|-------------------------------|-------------------------|
| Grayscale Imagery: | $C_m = 25\%$ | 1512 x 1252 |
| Text and Graphics | $C_m = 50\%$ | 975 x 884 |

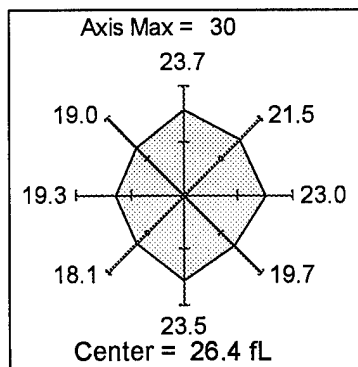
**Maximum Luminance
in Foot Lamberts**

Linewidth in Pixels (RAR)

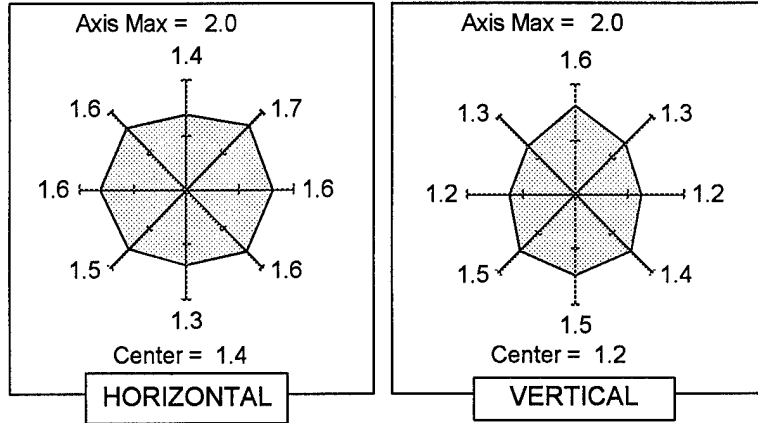

Contrast Modulation

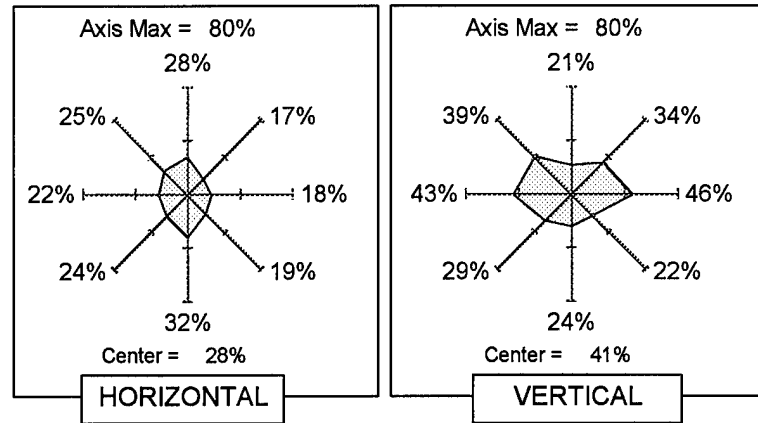

Misconvergence in Pixels

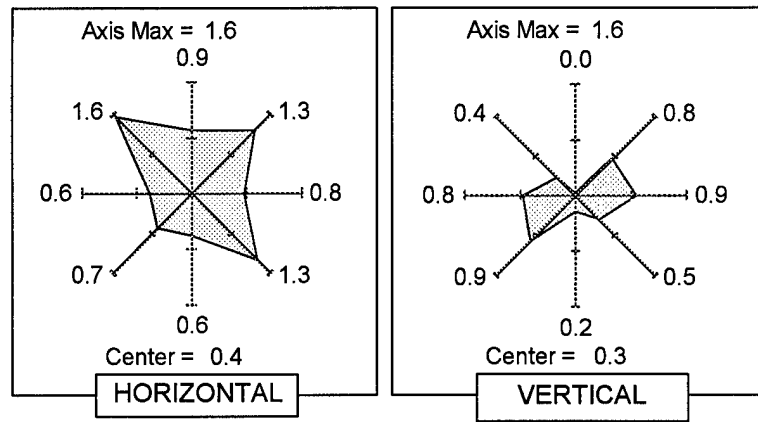

Waviness

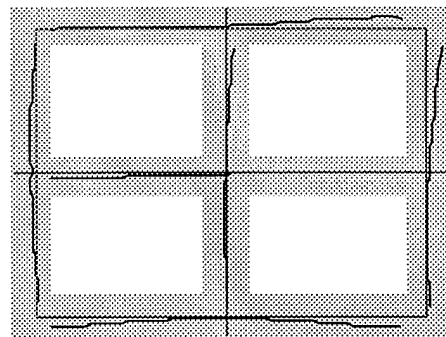

Gray band indicates ±1% distortion.

PHILIPS 2130DC**Manufacturer's Data**

| | |
|--------------------------|-------------------------------------|
| Manufacturer Name | Philips |
| Model Number | 2130DC |
| Price | \$2,699 |
| Screen Diagonal | 21 inches |
| Horizontal Scan Rate | 89.81 kHz |
| Vertical Scan Rate | 72.31 Hz |
| Image Size (H x V) | 15.0 x 11.2 inches |
| Addressable Pixel Number | 1600 x 1200 |
| Pixel Size | 9.36 x 9.36 mils (0.238 x 0.238 mm) |
| Dot Pitch | 11.0 mils (0.28 mm) |

Summary Comments:

- The monitor showed the least luminance variation over the screen.
- Based on a $C_m = 25\%$, this monitor resolved all of the addressable pixels.

Detailed Performance Data**Display Resolution**

| <u>Display Content</u> | <u>C_m Required</u> | <u>Resolution Limit</u> |
|------------------------|-------------------------------|-------------------------|
| Grayscale Imagery: | $C_m = 25\%$ | 1600 x 1194 |
| Text and Graphics | $C_m = 50\%$ | 1310 x 907 |

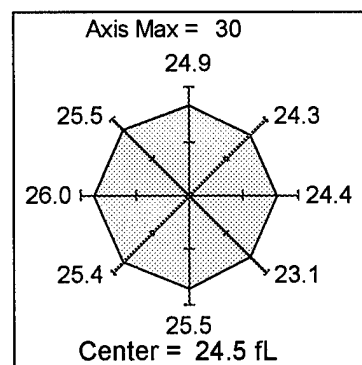
**Maximum Luminance
in Foot Lamberts**

Linewidth in Pixels (RAR)

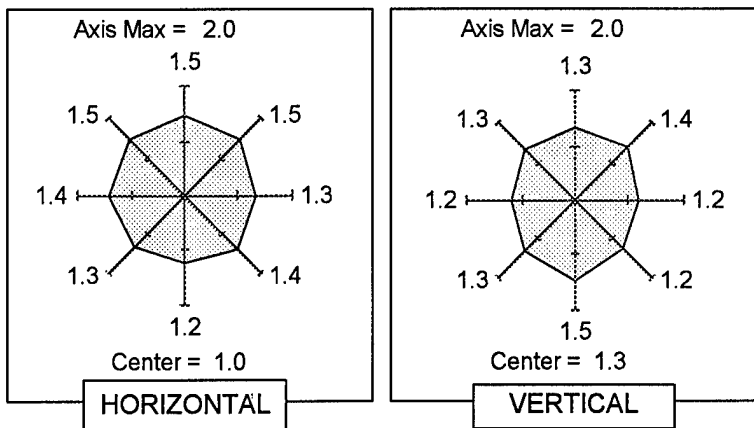

Contrast Modulation

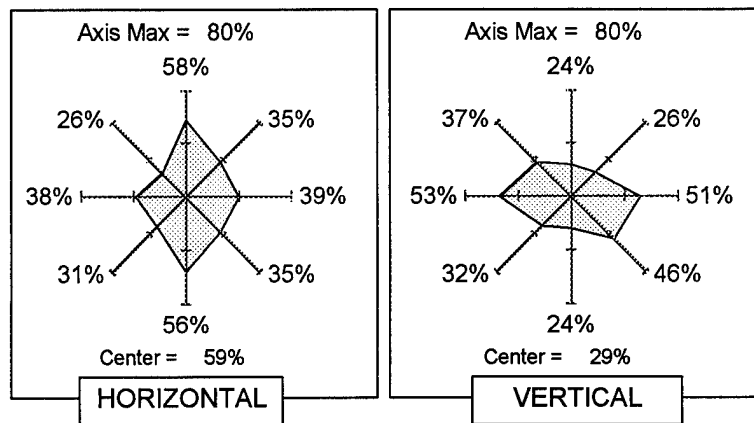

Misconvergence in Pixels

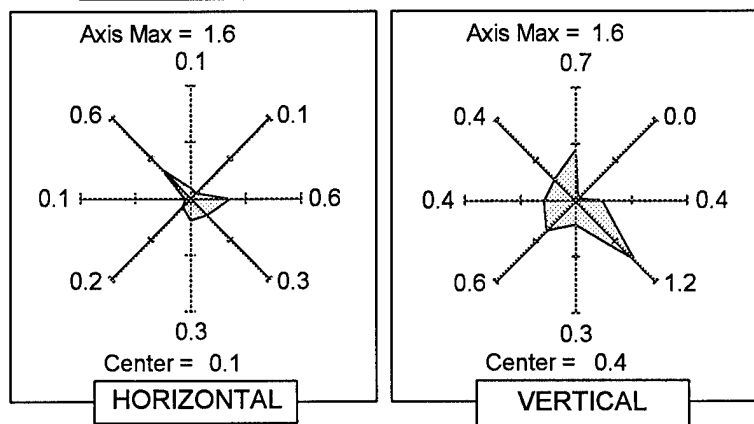

Waviness

