



Case Study: Structural Evaluation of Heavy Wood Trusses at Corpus Christi Army Depot, Texas

by Ghassan K. Al-Chaar, Dexter S. Yoon, and Pramod Desai

Army Regulation 420-70 requires the inspection of trusses, roof framing, and other structural items every 2 to 5 years (AR 420-70, par 3.21, app C). Building 8 at Corpus Christi Army Depot (CCAD), Texas, is an aircraft hangar/shop/office complex of timber construction. The roof trusses in Building 8 were inspected the U.S. Army Construction Engineering Research Laboratories (CERL) and the results were reported. The objectives of this study were to perform a complete, detailed structural evaluation of wood trusses and other support members (i.e., roof deck, beams/purlins, columns, etc.) of selected areas A, B, C, and D in Building 8 and to develop recommendations for appropriate retrofit schemes that will bring the structure into compliance with the latest requirements of the National Design Specification (NDS [AF & PA 1997]) and ANSI/ASCE 7-93, "Minimum Design Loads for Buildings and Other Structures."

Although the findings of this study pertain specifically to Building 8 at Corpus Christi Army

DTIC QUALITY INSPECTED 2

Approved for public release; distribution is unlimited.

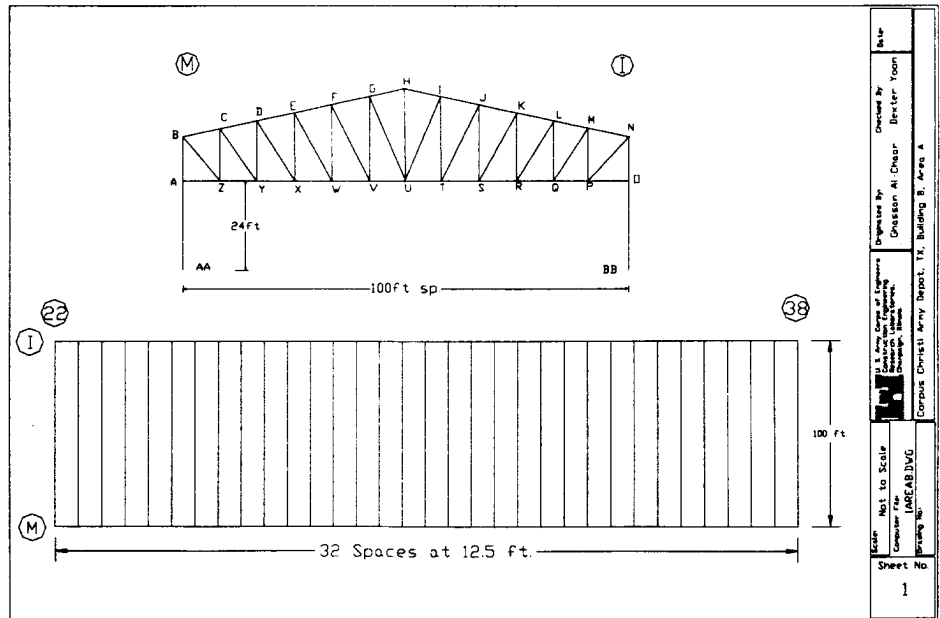

Depot, this report may be helpful to other Army installations for consideration as a case study when it is necessary to conduct periodic facility inspections IAW AR 420-70.

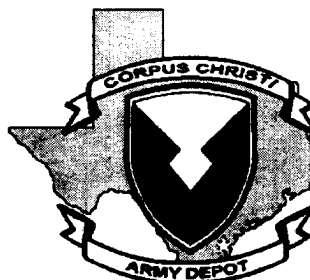

19990407 057

The contents of this report are not to be used for advertising, publication, or promotional purposes. Citation of trade names does not constitute an official endorsement or approval of the use of such commercial products. The findings of this report are not to be construed as an official Department of the Army position, unless so designated by other authorized documents.

DESTROY THIS REPORT WHEN IT IS NO LONGER NEEDED

DO NOT RETURN IT TO THE ORIGINATOR

USER EVALUATION OF REPORT

REFERENCE: USACERL Technical Report 99/26, *Case Study: Structural Evaluation of Heavy Wood Trusses at Corpus Christi Army Depot, Texas*

Please take a few minutes to answer the questions below, tear out this sheet, and return it to USACERL. As user of this report, your customer comments will provide USACERL with information essential for improving future reports.

1. Does this report satisfy a need? (Comment on purpose, related project, or other area of interest for which report will be used.)

2. How, specifically, is the report being used? (Information source, design data or procedure, management procedure, source of ideas, etc.)

3. Has the information in this report led to any quantitative savings as far as manhours/contract dollars saved, operating costs avoided, efficiencies achieved, etc.? If so, please elaborate.

4. What is your evaluation of this report in the following areas?

a. Presentation: _____

b. Completeness: _____

c. Easy to Understand: _____

d. Easy to Implement: _____

e. Adequate Reference Material: _____

f. Relates to Area of Interest: _____

g. Did the report meet your expectations? _____

h. Does the report raise unanswered questions? _____

i. General Comments. (Indicate what you think should be changed to make this report and future reports of this type more responsive to your needs, more usable, improve readability, etc.)

5. If you would like to be contacted by the personnel who prepared this report to raise specific questions or discuss the topic, please fill in the following information.

Name: _____

Telephone Number: _____

Organization Address: _____

6. Please mail the completed form to:

Department of the Army
CONSTRUCTION ENGINEERING RESEARCH LABORATORIES
ATTN: CECER-TR-I
P.O. Box 9005
Champaign, IL 61826-9005

REPORT DOCUMENTATION PAGE

Form Approved
OMB No. 0704-0188

Public reporting burden for this collection of information is estimated to average 1 hour per response, including the time for reviewing instructions, searching existing data sources, gathering and maintaining the data needed, and completing and reviewing the collection of information. Send comments regarding this burden estimate or any other aspect of this collection of information, including suggestions for reducing this burden, to Washington Headquarters Services, Directorate for Information Operations and Reports, 1215 Jefferson Davis Highway, Suite 1204, Arlington, VA 22202-4302, and to the Office of Management and Budget, Paperwork Reduction Project (0704-0188), Washington, DC 20503.

1. AGENCY USE ONLY (Leave Blank)	2. REPORT DATE February 1999	3. REPORT TYPE AND DATES COVERED Final
----------------------------------	---------------------------------	-------------------------------------------

4. TITLE AND SUBTITLE Case Study: Structural Evaluation of Heavy Wood Trusses at Corpus Christi Army Depot, Texas	5. FUNDING NUMBERS MIPR MP853Z0047D111, dated 3 Feb 98
----------------------------------------------------------------------------------------------------------------------	--------------------------------------------------------------

6. AUTHOR(S) Ghassan Al-Chaar, Dexter Yoon

7. PERFORMING ORGANIZATION NAME(S) AND ADDRESS(ES) U.S. Army Construction Engineering Research Laboratories (USACERL) P.O. Box 9005 Champaign, IL 61826-9005

8. PERFORMING ORGANIZATION REPORT NUMBER TR 99/26

9. SPONSORING / MONITORING AGENCY NAME(S) AND ADDRESS(ES) Corpus Christi Army Depot ATTN: SIOCC-DS-FE 308 Crecy St., Stop 30 Corpus Christi, TX 78419-5260

10. SPONSORING / MONITORING AGENCY REPORT NUMBER

11. SUPPLEMENTARY NOTES Copies are available from the National Technical Information Service, 5285 Port Royal Road, Springfield, VA 22161.

12a. DISTRIBUTION / AVAILABILITY STATEMENT Approved for public release; distribution is unlimited.

12b. DISTRIBUTION CODE

13. ABSTRACT (Maximum 200 words) Army Regulation 420-70 requires the inspection of trusses, roof framing, and other structural items every 2 to 5 years (AR 420-70, par 3.21, app C). Building 8 at Corpus Christi Army Depot (CCAD), Texas, is an aircraft hangar/shop/office complex of timber construction. The roof trusses in Building 8 were inspected the U.S. Army Construction Engineering Research Laboratories (CERL) and the results were reported. The objectives of this study were to perform a complete, detailed structural evaluation of wood trusses and other support members (i.e., roof deck, beams/purlins, columns, etc.) of selected areas A, B, C, and D in Building 8 and to develop recommendations for appropriate retrofit schemes that will bring the structure into compliance with the latest requirements of the National Design Specification (NDS [AF & PA 1997]) and ANSI/ASCE 7-93, "Minimum Design Loads for Buildings and Other Structures." Although the findings of this study pertain specifically to Building 8 at Corpus Christi Army Depot, this report may be helpful to other Army installations for consideration as a case study when it is necessary to conduct periodic facility inspections IAW AR 420-70.

14. SUBJECT TERMS wood trusses structural engineering evaluation Corpus Christi Army Depot, Texas

15. NUMBER OF PAGES 222

16. PRICE CODE

17. SECURITY CLASSIFICATION OF REPORT Unclassified

18. SECURITY CLASSIFICATION OF THIS PAGE Unclassified

19. SECURITY CLASSIFICATION OF ABSTRACT Unclassified

20. LIMITATION OF ABSTRACT SAR

Foreword

This study was performed for the Facilities Engineering and Management Division, Corpus Christi Army Depot (CCAD), TX, under Reimbursable Work Unit GL8, "Structural Repair to Wood Truss"; Military Interdepartmental Purchase Request (MIPR) MP853Z0047D111. The technical monitor was Mr. Robert Horton, SIOCC-DS-FE.

The work was performed by the Engineering Division (FL-E) of the Facilities Technology Laboratory (FL), U.S. Army Construction Engineering Research Laboratories (CERL). The CERL Principal Investigator was Ghassan K. Al-Chaar, CECER-FL-E. Larry M. Windingland is Acting Chief, CECER-FL-E, and L. Michael Golish is Acting Operations Chief, CECER-FL. The CERL technical editor was Gordon L. Cohen, Technical Information Team.

The authors acknowledge the work of Dr. Moussa Issa for his assistance in wind pressure design, Dr. Poo Chow for conducting the wood laboratory tests, Jason Petti for acquiring data, and Amador Garza for his search for drawings.

The authors acknowledge the assistance of the following Hangar Managers during inspection: Oscar Salinas, Manuel Garcia, Forty Garcia, Terry Figg, Robert Flores, Richard Medrano, and Hardi Boudissa.

Dr. Michael J. O'Connor is Director of CERL.

Contents

SF 298.....	1
Foreword.....	2
1 Introduction.....	9
Background.....	9
Objectives.....	9
Approach.....	9
Units of Weight and Measure.....	111
2 Inspection of Building 8 Wood Trusses.....	12
Description of the Small Hangar (Area A).....	12
Inspection of the Small Hangar (Area A).....	12
Description of Areas B, C, and D.....	14
Inspection of Area B, C, and D.....	14
3 Material Testing.....	17
Major Test Requirements.....	17
Specimens and Method of Testing.....	17
Test Results.....	18
4 Dead, Live, Point, and Wind Loads.....	20
Calculation of Dead, Live, Point Loads.....	20
Area A.....	20
Area B.....	20
Area C.....	21
Area D.....	22
Design of Wind Pressures for Area A Using ANSI/ASCE 7-95.....	22
Exposure and Structure Classification.....	23
Basic Wind Speed.....	23
Velocity Pressures.....	23
Summary of Wind Loads for Area A.....	28
Wind Pressures for Areas B, C, and D Using ANSI/ASCE 7-95.....	28
Exposure and Structure Classification.....	29
Basic Wind Speed.....	29
Velocity Pressures.....	29

5 Analytical Modeling and Results.....	35
Modeling and Analysis for Area A.....	35
Modeling and Analysis for Area B	36
Modeling and Analysis for Areas C and D.....	37
6 Retrofit and Repair Schemes	39
Recommended Retrofit and Repair in Area A	39
<i>Proposed Solution for General Deficiencies Discussed in Chapter 2</i>	<i>39</i>
<i>Proposed Solution for Specific Deficiencies Discussed in Chapter 2</i>	<i>39</i>
Recommended Retrofit and Repair in Areas B, C, and D.....	40
<i>Proposed Solution for General Deficiencies Discussed in Chapter 2</i>	<i>40</i>
<i>Proposed Solution for Specific Deficiencies Discussed in Chapter 2</i>	<i>40</i>
General Retrofit Structural Notes	41
7 Conclusions	43
References.....	85
Glossary.....	86
Appendix A: Inspection Tables for Area A.....	89
Appendix B: Inspection Tables for Area B.....	123
Appendix C: Inspection Tables for Area C.....	141
Appendix D: Inspection Tables for Area D.....	145
Appendix E: SAP90 Input and Output.....	151
Appendix F: Analytical Results for Members and Joints in Area A	169
Appendix G: Analytical Results for Members and Joints in Area B	183
Appendix H: Analytical Results for Members and Joints in Areas C and D.....	197
Appendix I: Diagrams of Proposed Repairs.....	211
Distribution	

List of Tables and Figures

Tables

1 Inspected areas in Building 8.....	44
2 Deficiency codes used in inspection forms of Appendices A, B, C, and D.	44
3 Number of deficiencies reported during inspection of Area A.*.....	45
4 Number of Deficiencies Reported During Inspection of Area B.*.....	46
5 Number of deficiencies reported during inspection of Area C.*.....	47
6 Number of deficiencies reported during inspection of Area D.*.....	48
7 List of damaged purlins.....	49
8 Southern Yellow Pine dimension lumber.....	49
9 Test specimens and methods.....	49
10 Static bending test results.....	50
11 Maximum tensile stress parallel to grain (average MC – 10.2%).....	50
12 Maximum horizontal shear stress.....	51
13 Maximum compressive stress parallel to grain.....	52
14 Compression perpendicular to grain.....	52
15 Average tested properties (psi) of Southern Yellow Pine.....	53
16 Average allowable strength properties for Southern Pine sample A.....	53
17 Average allowable strength properties for Southern Pine sample D.....	53

Figures

1 Plan view and typical truss in Area A.....	54
2 Location of leak traces and roof surfaces collecting water in Area A.....	54
3 Plan view and typical truss in Area B.....	55
4 Plan view and typical trusses in Areas C and D.....	55
5 Location of leak traces and roof surfaces collecting water in Area B.....	56
6 Location of leak traces and roof surfaces collecting water in Areas C and D.....	56
7 Location of heavy paint peeling from chemicals in Area B.....	57
8 Location of non-chemical paint peeling in Areas C and D.....	57
9 Wind pressure distribution on Area A.....	58

10	Wind pressure distribution on Areas B, C, and D.....	58
11	Maximum stress interaction in a typical truss in Area A.	59
12	Maximum stress interaction in a typical truss in Area B.....	59
13	Maximum stress interaction in a typical truss in Areas C and D.	60
14	Typical trusses in Areas B, C, and D.....	60

Photos

1	Column 29.5, Line M, damage by passing objects..	61
2	Misaligned slender column with loose bolts.....	62
3	Typical type of existing repair in Area A.	63
4	Typical existing repair in Area A.	64
5	Typical large split in a column in Area A.....	65
6	Typical small split in a column in Area A.	66
7	End split in a diagonal member in Building A.....	67
8	Decay due to leakage in Area A.	68
9	Major damage due to decay in a joint in Area A.....	69
10	Fracture in diagonal member BZ of Truss 34, Building A.....	70
11	Tension failure in diagonal member PN of Truss 38, Area A.	71
12	Fractured diagonal member CY of Truss 29.5, Area A.	72
13	Fractured diagonal member BZ of Truss 27, Area A.....	72
14	Fractured member QM of Truss 27, Area A.	73
15	Fractured CY diagonal member in Truss 34, Area A.....	73
16	Fractured diagonal member DX of Truss 36, Area A.	74
17	Fractured diagonal member QM of Truss 36.5, Area A.....	74
18	Cantilever pipe support on diagonal members of Truss 34, Area A.....	75
19	Water collected on the roof surface of Area B.....	76
20	Pond and sag in the roof of Area D.	76
21	Over stressed purlin.	77
22	Using the coring on termite damaged column.	77
23	Using the moisture content meter on termite damaged column.	78
24	Using the V-Meter on termite damaged column.....	78
25	Leakage from a sink that will damage a column.	79
26	Fractured chord of Truss 40, Section IG, Area B.	79
27	Fracture in chord RT line 56, Area D.....	80
28	Fracture on member CT of column line 63.....	80
29	Specimens cut and conditioned in a chamber at 68 percent humidity and 67 °F.	81

30	Static bending test.....	81
31	Tension parallel-to-grain test.	82
32	Shear parallel-to-grain test.....	82
33	Typical failure for compression parallel-to-grain test.....	83
34	Compression parallel-to-grain test with deformation gauge.	83
35	Compression perpendicular-to-grain test.....	84
36	Endorsed repair for a fractured diagonal member.	84

1 Introduction

Background

Army Regulation 420-70 requires the inspection of trusses, roof framing, and other structural items every 2 to 5 years (AR 420-70, par 3.21, app C). Building 8 at Corpus Christi Army Depot (CCAD), Texas, is an aircraft hangar/shop/office complex of timber construction. The roof trusses in Building 8 were inspected in May 1996 by the U.S. Army Construction Engineering Research Laboratories (CERL). A letter report dated 17 June 1996 on the result of that inspection was submitted to the sponsor (Al-Chaar 1996). The report identified deficiencies in the structures that were determined by inspection, and recommended a detailed structural evaluation of Areas A, B, C, and D in Building 8.

Objectives

The objectives of this study were to perform a complete, detailed structural evaluation of wood trusses and other support members (i.e., roof deck, beams/purlins, columns, etc.) of selected areas A, B, C, and D in Building 8, CCAD, and to develop recommendations for appropriate retrofit schemes that will bring the structure into compliance with the latest requirements of the National Design Specification (NDS [AF & PA 1997]) and ANSI/ASCE 7-93, "Minimum Design Loads for Buildings and Other Structures."

Approach

The evaluation procedure used in this analysis is based on allowable stress design (ASD) design practices. All parameters that describe existing conditions of the structures that may increase or decrease the actual and allowable stresses were identified and included in the final evaluation procedure. A detailed inspection was carried out prior to analysis to check the as-built and existing conditions of the structural members. The inspection objectives were to: (1) identify deficiencies that can be repaired to restore the strength of members to their original design strength or possibly stronger and (2) collect data on the attached loads that needed to be considered in the analysis.

Models representing the current conditions of the structures were developed and used for structural analysis. These models were subjected to two combinations of loading: the first consisting of dead load, live load, and point load; the second consisting of dead load, point load, and wind load. A detailed analysis was performed such that the models best duplicated the actual conditions of the structures under consideration, resulting in the computation of maximum capacity-demand ratios for all members and joints. All wood truss members and other support members (i.e., deck, beams/purlins, columns and joints) in the building were evaluated, and the capacity-demand ratios were computed and reported. In the course of this evaluation, structural deficiencies were identified and reported. Members with obvious signs of decay reported during the earlier inspection were recommended either for repair before detailed evaluation, or a strength-reduction estimate was incorporated into the analysis.

Deficiencies found during inspection were reported, and strength-restoring repair techniques were proposed. All members and joints with capacity-demand ratios greater than 1 were recommended for repair or were exempt due to the margin of safety included in the calculations. Retrofit schemes and repair techniques were then recommended. The structural analysis models were modified to include the proposed retrofit schemes and reanalyzed to ensure that the capacity-demand ratios of all members fell within allowable limits.

Scope

Although the findings of this study pertain specifically to Building 8 at Corpus Christi Army Depot, this report may be helpful to other Army installations for consideration as a case study when it is necessary to conduct periodic facility inspections IAW AR 420-70.

Units of Weight and Measure

U.S. standard units of measure are used throughout this report. A table of conversion factors for Standard International (SI) units is provided below.

SI conversion factors		
1 in.	=	2.54 cm
1 ft	=	0.305 m
1 sq ft	=	0.093 m ²
1 cu ft	=	0.028 m ³
1 lb	=	0.453 kg
1 ft-lb	=	1.356 joules
1 psi	=	6.89 kPa
°F	=	(°C x 1.8) + 32

2 Inspection of Building 8 Wood Trusses

Areas A, B, C, and D in Building 8 of CCAD comprise 153,600 sq ft of wood trusses, purlins supporting wood decks, and built-up roofs. The names, boundary column lines, and sizes of the inspected areas are shown in Table 1.

Description of the Small Hangar (Area A)

Area A has 32 trusses supported by 64 wood columns. The trusses span 100 ft in the east-west direction, supported between two wooden columns. Area A is located between column lines I and M, and column lines 22 and 38, each spaced at 12.5 ft.

Plan view, typical truss configuration and member identifications are presented in Figure 1. (Drawing reference NAVFAC DWG 5265187.) Sixty-four wood columns support the trusses at a 24 ft clear height from the ground. The roof consists of built-up roof over a 2 in. wood deck.

Inspection of the Small Hangar (Area A)

The inspection identified the following **general** deficiencies:

1. The structure was built in 1942, so the bolts are somewhat loose. A few bolts were tested and it was concluded that they could be tightened about one turn. It is recommended that all accessible bolts be tightened to 70 ft-lb.
2. Over time, some of the 32 columns along column line M have been hit by passing sharp objects and gouged. These columns are located in heavy traffic areas and must be protected. A typical column damaged by passing objects is shown in Photo 1. See Chapter 6 for recommended protection scheme.
3. Major signs of roof leaks were observed in several areas. The roof may have been repaired for some leaking areas, but some surfaces on the roof are still collecting water and may be actively leaking. All traces of leaking observed from inside the structure and roofing surfaces that are still collecting water are shown in Figure 2. Roof repair is recommended. Also, the roof should be inspected during heavy rain to assure the protection of the wood members supporting the roof.

4. Exterior columns were misaligned along their weak axes, as shown in Photo 2. These columns are considered slender and may potentially buckle. A retrofit scheme is proposed in Chapter 6.

Sixty-four columns, trusses, purlins, decks, and lateral braces were inspected for damage. The results of the inspection are reported in detail in Appendix A. For every truss in Area A, a table was developed containing a list of members in each truss, as identified in Figure 1. The codes used to identify deficiencies are defined in Table 2. Finally, the numbers of identical deficiencies observed in identical trusses of the same labels are summarized in Table 3. Based on the data presented in Table 3, the following **specific** observations were made:

1. A total of 72 chords were repaired for longitudinal splits along their neutral axes. It was found that another 141 members, nearly 9% of the total, have damage similar to those repaired. The seriousness of these splits was determined based on the factors of safety for these defective members, as calculated in the detailed analysis. These members are considered to have minor damage for a factor of safety less than 0.75. However, the presence of splits implies a reduction of the member's strength. Photos 3 and 4 show typical repairs, and Photo 5 shows a typical large split in a column in Area A.
2. A total of 176 members were identified as having minor splits. These splits should be closely monitored during the next inspection. See Photo 6 for a typical small split in a column in Area A.
3. A total of 135 end splits were counted, but access to 74 of the 135 may require removing exterior wood siding. See Photo 7 for a typical end split in a diagonal member in Area A. Recommended repairs are specified in Chapter 6.
4. A total of 13 splice splits were counted—4 on tension members and 9 on compression members. Repair is recommended in Chapter 6.
5. Decay was observed on 37 members. Repair is recommended based on the degree of decay and degree of stress in each member as determined by analysis. See Photo 8 for a typical decay of a member in Area A.
6. Decay was found in joint B, Truss 24.5. See Photo 9. The bolts are loose, and repairs are recommended in Chapter 6.
7. Eight diagonal members were found to be fractured, as shown in Photos 10 through 17. These members are: BZ and QM in Truss 27, CY in Truss 29.5, BZ and CY in Truss 34, DX in Truss 36, QM in Truss 36.5, and PN in Truss 38. See Chapter 6 for repair recommendations.
8. Truss 34 supports a pipe on cantilevers spanning in the out-of-plane direction, as shown in Photo 18. This connection is unacceptable on wood trusses. Wood trusses are not usually designed to carry moment along their planes. See Chapter 6 for a retrofit scheme.

Description of Areas B, C, and D

Areas B, C, and D are structurally considered one building, sharing interior columns and interior and exterior walls.

Area B, the Engine Cleaning Room, has 108 trusses supported by 135 columns. As illustrated in Figure 3, Area B is located between column lines A-I and 38-64. The inspection was performed on 100 trusses spanning 50 ft and spaced 16 ft apart. The total length of structure is 416 ft in the longitudinal direction and 200 ft in the transverse direction. A typical wood truss in Area B is shown in Figure 3.

Areas C and D, Engine Disassembly and Repair, are located between column lines A-DD and 45-64. The inspection was performed on 54 trusses spanning 50 ft and spaced 16 ft apart. As shown in Figure 4, the total length of structure is 304 ft in the longitudinal direction and 100 ft in the transverse direction. Typical wood trusses in Areas C and D are shown in Figure 4.

Inspection of Area B, C, and D

The inspection identified the following **general** deficiencies:

1. As in Area A, the bolts are not tight. A few bolts were tested and it was concluded that they could be tightened about one turn. It is recommended that all accessible bolts be tightened to approximately 70 ft-lb.
2. Major signs of roof leaks were observed in several areas. Some of the leaking areas of the roof may have been repaired, but surfaces on the roof are still collecting water and may be actively leaking, as shown in Photos 19 and 20. All traces of leaks observed from the inside of the structure and from the surfaces on the roof that are still collecting water are shown in Figures 5 and 6. Roof repair is recommended. Also, the roof should be inspected during heavy rain to ensure the protection of the wood members supporting the roof.
3. Paint is peeling due to chemicals. The wood truss between column E46 and G46 in the Engine Cleaning Area exhibits paint peeling and has dark brown burns from chemical reactions. Figures 7 and 8 show the location of the problem areas. Paint should be applied more frequently in these areas to protect the trusses from progressive damage.

Columns, trusses, purlins, decks, and lateral braces were inspected for damage. The results of the inspection for each area are reported in detail in Appendices B, C, and D, respectively. For every truss in Areas B, C, and D, a table was

developed that shows a list of members in each truss, as identified in Figures 3 and 4. The codes used to identify deficiencies are defined in Table 2. The numbers of identical deficiencies observed in identical trusses of the same labels are summarized in Tables 4, 5, and 6. Based on the data presented in these tables, the following **specific** observations were made:

1. A total of 58, 3, and 0 members in Areas B, C, and D, respectively, were found to have been repaired previously for the presence of longitudinal splits along their neutral axes. It was found that another 61, 29, and 13 members in Areas B, C, and D, respectively, have similar damage as those repaired. The seriousness of these splits was determined based on the factors of safety of these defective members calculated in the detailed analysis. These members are considered to have minor damage when the factor of safety is less than 0.75. However, the presence of splits implies a reduction in the member's strength.
2. A total of 227, 57, and 41 members in Areas B, C, and D, respectively, were found to have minor splits. These splits have been reported and should be closely monitored during the next inspection.
3. End splits were counted in Area B to total 108, but only 88 of the 108 are easily accessible. In Area C, 23 of the 24 end splits are easily accessible. Similarly, 35 members with end splits were found in Area D, of which 30 are easily accessible for repair. Recommended repairs (if any) are specified in Chapter 6.
4. No splits in splices were found.
5. Signs of decay were observed on 51 members. Repair is recommended based on the degree of decay and degree of stress in each member, as determined by analysis.
6. Purlins listed in Table 7 and identical to the one in Photo 21 are overstressed. These purlins have a major split longitudinally near the neutral axis of the beams.
7. Columns C39, E39, and G39 have missing knee braces. These braces were removed and never reinstalled in their original positions. Identical knee braces should be installed in place of the missing knee braces to restore the structure to its original design. Also, a knee brace removed from the truss on column line 48 between column lines BB and AA must be replaced (knee column BB and 48). This brace was removed for laboratory testing to determine the mechanical properties of the wood.
8. Column C63 exhibited termite damage, but termites were not seen. A nearby steamer was moved to another location. It may be inferred that the termites left after the steamer was moved because of the resulting reduction in moisture, which may have made the environment less attractive to termites. Photos 22, 23, and 24 show the condition of this column. Field tests were carried out to estimate the damage. See Chapter 6 for repair recommendations.

9. A sink in Area C, column line 53, will cause damage to the adjacent column, as shown in Photo 25. Isolating the sink from the column is recommended.
Moisture content from 18% to 23% is a potential start for termites.
10. The truss in column line 40, between column line I and G, has a fracture in the top chord between joints J and K, as shown in Photo 26. See Chapter 6 for recommended repair.
11. There is a fractured member in a truss on column line 56, Area D, located on the lower chord of the truss, between Joints R and T, as shown in Photo 27. See Chapter 6 for recommended repair.
12. Diagonal member CT in Truss 63 of Area B was found fractured, as shown in Photo 28. See Chapter 6 for recommended repair.

3 Material Testing

The objective of carrying out laboratory tests was to determine key physical and mechanical properties of wood samples extracted from Areas A and D of Building 8. These tests determined the comparable NDS code grade and species as well as the allowable stresses that reflect the actual condition of the wood materials.

Definitions of terms used in this chapter may be found in the Glossary, which is after the reference list immediately following the body of the report.

Major Test Requirements

The following tests were conducted:

1. static bending (1 in. x 1 in. x 16 in.)
2. tension parallel to grain (1 in. x 1 in. x 18 in.)
3. shear stress parallel to grain (2 in. x 2 in. x 2-1/2 in.)
4. compression parallel to grain (2 in. x 2 in. x 8 in.)
5. compression perpendicular to grain (2 in. x 2 in. x 6 in.)
6. wood species and grade
7. specific gravity and moisture content.

All tests were conducted in accordance with ASTM D 245-93 and D 2555-95 methods (References 6 and 7).

Specimens and Method of Testing

Two sets of wood samples (3 in. x 8 in. nominal size dimension lumber) were removed from Areas A and D. They were all identified as the southern pine wood species. Blue stain in the sapwood (light-color wood) area of all samples was observed. The nominal size of samples A-1, A-2, A-3, A-4, D-1, and D-2 was 3 in. x 8 in., which belongs to 2 in. to 4 in. thick and 8 in. wide category of southern pine dimensional lumber. Its intended use is in structural light framing and scaffold plank construction (References 3 and 5).

Table 8 shows the dimensions and specific gravities of the tested samples. Table 9 and Photo 29 show five different kinds of test specimens that were cut from the two sample sets, A and D. First, the specimens were conditioned at a relative humidity of 65% and a temperature of 68 °F for a period of at least 72 hours. They were then subjected to five mechanical tests using a universal testing machine, following standard ASTM D-143 test procedures (Reference 3). Both the average moisture content and specific gravity value for each specimen also were determined.

Test Results

Static bending, tensile, shear and compressive strengths are shown in Tables 10 – 17. The average specific gravity, which is based on oven-dry weight and air-dry volume of each specimen, was determined to be 0.68 and 0.547 for groups A and D, respectively (Tables 10, 13, and 14). The average moisture-content values were 10.5% and 11.6% for groups A and D, respectively (Table 10). The average number of annual rings per inch was also measured for all specimens. It ranged from 10 – 16 and 6 – 10 rings per inch for specimen groups A and D, respectively.

The test results are presented in the following tables and photos:

- Static bending—Table 10, Photo 30
- Tension—Table 11, Photo 31
- Shear—Table 12, Photo 32
- Compression parallel to grain—Table 13, Photos 33 and 34
- Compression perpendicular to grain—Table 14, Photo 35.

Almost all of the static bending tests showed a simple tension failure at mid-span of each specimen. In tension testing parallel to grain, more than 50% of the specimens did not fail at the mid-section. The mid-section is usually considered the weakest area because it tends to have a smaller cross-section than the ends. This result confirms that wood is not a homogeneous material. The test results for every specimen were recorded in a load-deflection chart.

The two sets of southern pine dimensional lumber samples tested here for ultimate static bending, tension, shear, compression parallel to the grain, and compression perpendicular to the grain had an average conditioned moisture content of about 12%. Table 15 contains the consolidated test results for sample sets A and D. For comparison purposes, average test values obtained from four major southern pine species were also included. The average specific gravity of

the southern pine samples was 0.55, as determined in accordance with AR 420-70 and ASTM D 245-93.

Based on the limited quantity of test data, the allowable design stress values were derived for both sample sets A and D, as shown in Tables 16 and 17. In summary:

1. After more than 40 years of service, timber sample set A remains structurally sound and of high strength. The average test values are comparable to published book values for clear southern pine lumber (tested at dry condition). Sample set A can still be rated as the Dense Select Structural (DSS) grade of southern pine dimensional lumber (2 in. to 4 in. thick, 8 in. wide).
2. Sample set D had lower average specific gravity and strength property values than those for sample set A, and is rated as the non-Dense Select Structural grade of southern pine dimensional lumber (2 in. to 4 in. thick, 8 in. wide).
3. The blue stain found in the sapwood area of all samples did not affect the strength property of the tested specimens or old southern pine lumber. However, this blue-stained lumber is susceptible to a variety of destructive decay and fungi, especially in wet conditions. For safety, the grade for Sample sets A and D could be lowered to No. 1 Dense and No. 1 non-Dense, respectively.

4 Dead, Live, Point, and Wind Loads

Calculation of Dead, Live, Point Loads

Area A

Bur (5 ply felt and gravel)	6 psf (pounds per square foot)
Insulation (fiberboard)	1.5 psf
Vapor Barrier	0.3 psf
Decking (2 in. Douglas Fir)	5 psf
Total:	12.8 psf for the assumed roof system

Tributary Area 12.5 ft x 100 ft

$$12.8 \text{ psf} \times 12.5 \text{ ft} = 160 \text{ lb/ft}$$

Self Weight of Truss A = 101.24 lb/ft

Total Dead Load = $160 + 101.24 = 261.3 \text{ lb/ft}$

Live Load = 20 psf

The wood trusses in the small hanger support conduits, pipes, and small equipment. All loads resulting from such equipment and fittings were estimated to be significantly less than 1000 lb per joint along the bottom chords. It was found that the original design considered point loads of 3000 lb (see Structural Drawing Y&D Drwg No. 210691). Point loads of 3000 lb per each joint of the bottom chord of each truss were considered in the analysis.

Area B

Bur (5 ply felt and gravel)	6 psf
-----------------------------	-------

Insulation (fiberboard)	1.5 psf
Vapor Barrier	0.3 psf
<u>Decking (2 in. Douglas Fir)</u>	<u>5 psf</u>
Total:	12.8 psf for the assumed roof system

Tributary Area: 16 ft X 50 ft

$$12.8 \text{ psf} \times 16 \text{ ft} = 204.8 \text{ lb/ft}$$

Self Weight of Truss B = 56.9 lb/ft

Total Dead Load = $204.8 + 56.9 = 261.7 \text{ lb/ft}$

Live load = 20 psf (see Structural Drawing Y&D Drwg No. 210691)

Area C

Bur (5 ply felt and gravel)	6 psf
Insulation (fiberboard)	1.5 psf
Vapor Barrier	0.3 psf
<u>Decking (2 in. Douglas Fir)</u>	<u>5 psf</u>
Total:	12.8 psf for the assumed roof system

Tributary Area: 16 ft x 50 ft

$$12.8 \text{ psf} \times 16 \text{ ft} = 204.8 \text{ lb/ft}$$

Self Weight of Truss B = 59.02 lb/ft

Total Dead Load = $204.8 + 59.02 = 263.82 \text{ lb/ft}$

Live Load = 20 psf

Point loading of 1000 lb per joint of the bottom chord is assumed for each truss.

Area D

Bur (5 ply felt and gravel)	6 psf
Insulation (fiberboard)	1.5 psf
Vapor Barrier	0.3 psf
<u>Decking (2 in. Douglas Fir)</u>	<u>5 psf</u>
Total:	12.8 psf for the assumed roof system

Tributary Area: 16 ft x 50 ft

$$12.8 \text{ psf} \times 16 \text{ ft} = 204.8 \text{ lb/ft}$$

Self Weight of Truss B = 59.02 lb/ft

Total Dead Load = 204.8 + 59.02 = 263.82 lb/ft

Total Load = D.L + W.L + L.L

$$= 263.82 \text{ lb/ft} + 40 \text{ psf} (16 \text{ ft}) + 20 \text{ psf} (16 \text{ ft})$$

$$= 1223.82 \text{ lb/ft} = \mathbf{0.102 \text{ kip/in.}}$$

Design of Wind Pressures for Area A Using ANSI/ASCE 7-95

Pertinent data from the hanger are as follows:

Location: Corpus Christi, TX

Terrain: Coastal area; building is surrounded by other structures.

Dimensions: 100 ft x 400 ft in Plan (Area A)

Eave height of 35 ft

Roof Slope of 8.5 degrees (Flat)

Ridge height is 40 ft

Exposure and Structure Classification

The structure is located in a coastal region, but it is connected to and shielded by other structures. Use **Exposure Category C** (sec. 6.5.3).

The structure function is industrial-military, used as an essential facility.

Use Category IV, **Importance Factor (I) = 1.15** (ANSI/ASCE 7-95, Table 1-1).

Basic Wind Speed

Select wind speed as per ANSI/ASCE 7-95, sec. 6.5.2 and Table 6-1.

Basic Wind Speed (V) = 130 mph (Table 6-1).

Velocity Pressures

The velocity pressures are computed using:

$$q_z = (0.00256) * (K_z) * (K_{zt}) * (V^2) * (I) \text{ psf (ANSI/ASCE 7-95, Eq 6-1).}$$

K_z is obtained from Ref. 5, ANSI/ASCE 7-95, Table 6-3.

$$K_{zt} = 1.0$$

$$I = 1.15$$

$$V = 130 \text{ mph}$$

Then Eq 6-1 $q_z = (0.00256) * (K_z) * (1.0) * (130^2) * (1.15)$

$$q_z = 49.75 * (K_z) \text{ psf}$$

Note: since $\theta = 8.5 \text{ degrees} \leq 10 \text{ degrees}$, use eave height for mean roof height ($h_m = 40 \text{ ft}$)

Velocity pressures are as follows:

Height, ft	K_z	q_z, psf
0-15	0.85	42.0

	25	0.94	47.0
Mean Roof Height	35	1.01	50.0
Ridge Height	40	1.04	52.0

Design wind pressures for the main wind-force resisting system (**MWFRS**) are calculated using the equation below, from ANSI/ASCE 7-95, Table 6-1:

$$p = q * (GC_p) - q_h * (GC_{pi})$$

where:

$q = q_z$ for windward wall at height Z above the ground

$q = q_h$ for leeward wall, side walls, and roof

$G = 0.85$ for Exposure C (sec. 6.6.1)

$C_p =$ values obtained from ANSI/ASCE 7-95, Figure 6-3

$(GC_{pi}) =$ values obtained from ANSI/ASCE 7-95, Table 6-4.

Note: When the wind is normal to the ridge, the windward roof experiences both positive and negative external pressures. Combining these external pressures with positive and negative internal pressures will result in four loading cases when wind is normal to the ridge. When wind is parallel to the ridge, positive and negative internal pressures result in two loading cases.

For Wall C_p , from ANSI/ASCE 7-95, Figure 6-3, the pressure coefficients for the windward wall and for the side walls are 0.80 and -0.70, respectively, for all L/B ratios.

The leeward wall pressure coefficient is a function of the L/B ratio. For wind normal to the ridge, $L/B = 100/400 = 0.25$; therefore, the leeward wall pressure is -0.50. When flow is parallel to the ridge, $L/B = 400/100 = 4.0$, the corresponding value of C_p is -0.20.

The wall pressure coefficients are summarized below:

Wall C_p

<u>Surface</u>	<u>Wind Dir.</u>	<u>L/b</u>	<u>C_p</u>
Windward Wall	All	All	0.80
Leeward Wall	Normal to Ridge	0.25	-0.50
		Parallel to Ridge	4.00 -0.20
Side Wall	All	All	-0.70

Wind Normal to the 400 ft Face-Ridge

$$h/L = 32/100 = 0.32 < 0.50 \text{ and since } \theta \leq 10 \text{ degrees}$$

Then: windward and leeward Roof $C_p = -0.90$ from $0-h$

windward and leeward Roof $C_p = -0.50$ from $h-2h$

windward and leeward Roof $C_p = -0.30$ from $>2h$

Internal GC_{pi} (ANSI/ASCE 7-95, Table 6-4)

The site is in a hurricane-prone region and has wind speeds equal to or greater than 110 mph. Positive Internal Pressure $GC_{pi} = +0.80$

Negative Internal Pressure $GC_{pi} = -0.30$

MWFRS Net Pressures

$$p = q *(GC_p) - q_h *(GC_{pi})$$

Where :

$q = q_z$ for windward wall at height Z above the ground

$q = q_h$ for leeward wall, side walls, and roof

$p = q *(0.85)*(C_p) - 50.0*(+GC_{pi})$ +Ve Internal Pressure

$p = q *(0.85)*(C_p) - 50.0*(-GC_{pi})$ -Ve Internal Pressure

Typical Calculation: Windward Wall, 0 - 15 ft

Wind Normal to Ridge:

$$p = 47*(0.85)*(0.8) - 50.0*(+0.8) \quad +\text{Ve Internal Pressure}$$

$$P = -8.04 \text{ psf, with +Ve Internal Pressure}$$

$$p = 47.0*(0.85)*(0.80) - 50.0*(-0.3) \quad +\text{Ve Internal Pressure}$$

$$P = 47 \text{ psf, with -Ve Internal Pressure}$$

Typical Calculation: Roof, 0 - 50 ft from edge

Wind Normal to Ridge:

$$p = 50*(0.85)*(-0.5) - 50.0*(+0.8) \quad +\text{Ve Internal Pressure}$$

$$P = -61.0 \text{ psf, with +Ve Internal Pressure}$$

$$p = 50.0*(0.85)*(-0.5) - 50.0*(-0.3) \quad +\text{Ve Internal Pressure}$$

$$P = -6.0 \text{ psf, with -Ve Internal Pressure}$$

Net MWFRS Pressures: Wind Normal to Ridge

Surface	Height (z), ft	q_z , psf	C_p	Net Pressure, psf	
				(+GC _{pl})	(-GC _{pl})
Windward Wall	0-15	42.0	0.80	-11.4	44.0
	25	47.0	0.80	-8.1	47.0
Mean Roof Height	35	50.0	0.80	-6.0	49.0
Ridge Height	40	52.0	0.80	-5.0	50.0
Leeward Wall	All	50.0	-0.50	-61.0	-6.0
Side Walls	All	50.0	-0.70	-70.0	-15.0
Windward and Leeward Roof	0-h*	50.0	-0.50	-61.0	-6.0
	h-2h*	50.0	-0.50	-61.0	-6.0
	>2h*	50.0	-0.30	-53.0	+2.0

* Distance from windward edge.

Wind Parallel to Ridge

If $h/L = 32/400 = 0.08 < 0.50$, and since $\theta \leq 10$ degrees

then: windward and leeward Roof $C_p = -0.90$ from $0-h$

windward and leeward Roof $C_p = -0.50$ from $h-2h$

windward and leeward Roof $C_p = -0.30$ from $>2h$

Internal GC_{pi} (ANSI/ASCE 7-95, Table 6-4)

The site is in a hurricane-prone region and has wind speeds equal to or greater than 110 mph. Positive Internal Pressure $GC_{pi} = +0.80$

Negative Internal Pressure $GC_{pi} = -0.30$

MWFRS Net Pressures

$$p = q * (GC_p) - q_h * (GC_{pi})$$

where:

$q = q_z$ for windward wall at height Z above the ground

$q = q_h$ for leeward wall, side walls, and roof

$$p = q * (0.85) * (C_p) - 50.0 * (+GC_{pi}) \quad \text{+Ve Internal Pressure}$$

$$p = q * (0.85) * (C_p) - 50.0 * (-GC_{pi}) \quad \text{-Ve Internal Pressure}$$

Typical Calculation: Windward Wall, 0 - 15 ft

Wind Parallel to Ridge:

$$p = 47 * (0.85) * (0.8) - 50.0 * (+0.8) \quad \text{+Ve Internal Pressure}$$

$$P = -8.04 \text{ psf, with +Ve Internal Pressure}$$

$$p = 47.0 * (0.85) * (0.80) - 50.0 * (-0.3) \quad \text{+Ve Internal Pressure}$$

$$P = 47 \text{ psf, with -Ve Internal Pressure}$$

Typical Calculation: Roof, 0 - 50 ft from edge

Wind Parallel to Ridge:

$$p = 50*(0.85)*(-0.5) - 50.0*(+0.8) \quad +\text{Ve Internal Pressure}$$

$$P = -61.0 \text{ psf, with } +\text{Ve Internal Pressure}$$

$$p = 50.0*(0.85)*(-0.5) - 50.0*(-0.3) \quad +\text{Ve Internal Pressure}$$

$$P = -6.0 \text{ psf, with } -\text{Ve Internal Pressure}$$

Net MWFRS Pressures: Wind Parallel to Ridge

Surface	Height (z), ft	q _z , psf	C _p	Net Pressure, psf	
				(+GC _{ps})	(-GC _{ps})
Windward Wall	0-15	42.0	0.80	-11.4	44.0
	25	47.0	0.80	-8.1	47.0
Mean Roof Height	35	50.0	0.80	-6.0	49.0
Ridge Height	40	52.0	0.80	-5.0	50.0
Leeward Wall	All	50.0	-0.20	-49.0	-7.0
Side Walls	All	50.0	-0.70	-70.0	-15.0
Windward and Leeward Roof	0-h*	50.0	-0.50	-61.0	-6.0
	h-2h*	50.0	-0.50	-61.0	-6.0
	>2h*	50.0	-0.30	-53.0	+2.0

* Distance from windward edge.

Summary of Wind Loads for Area A

Uplift Wind Load = 30 psf = 0.03125 k/in. (kilopounds per inch)

Load at Side of West Direction due to Wind = 45 psf x 12.5ft = 0.047 k/in.

Load at Side of East Direction due to Wind = 20 psf x 12.5 ft = 0.0208 k/in.

Load at West of Column due to Wind = 20 psf x 12.5 ft = 0.0208k/in.

Load at East of Column due to Wind=10 psf x 12.5ft = 0.0104k/in.

See Figure 9 for a summary of wind pressure loads on Areas A.

Wind Pressures for Areas B, C, and D Using ANSI/ASCE 7-95

Pertinent data for Areas B, C, and D are as follows:

Location: Corpus Christi, TX

Terrain: Coastal area; building is surrounded by other structures.

Dimensions: 300 ft x 416 ft in Plan (Areas B, C, and D)

Bottom of Truss height is 16 ft

Flat Roof

Roof height is 24 ft

Exposure and Structure Classification

The structure is located in a coastal region, but it is connected to and shielded by other structures. Use **Exposure Category C** (sec. 6.5.3).

The structure function is industrial-military, used as an essential facility.

Use Category IV, **Importance Factor (I) = 1.15** (ANSI/ASCE 7-95, Table 1-1).

Basic Wind Speed

Select wind speed as per ANSI/ASCE 7-95, sec. 6.5.2, Table 6-1.

Basic Wind Speed (V) = 130 mph (Table 6-1).

Velocity Pressures

The velocity pressures are computed using:

$$q_z = (0.00256) * (K_z) * (K_{zt}) * (V^2) * (I) \text{ psf (ANSI/ASCE 7-95, Eq 6-1).}$$

K_z is obtained from ANSI/ASCE 7-95, Table 6-3.

$$K_{zt} = 1.0$$

$$I = 1.15$$

$$V = 130 \text{ mph}$$

Then Eq 6-1 $q_z = (0.00256) * (K_z) * (1.0) * (130^2) * (1.15)$

$$q_z = 49.75*(K_z) \text{ psf}$$

Note: since $\theta = 0$ degrees (flat roof), use $h_m = 24$ ft

Velocity Pressures are as follows:

	<u>Height, ft</u>	<u>K_z</u>	<u>q_z, psf</u>
	0-15	0.85	42.0
Mean Roof Ht.	24	0.94	47.0

Design Wind Pressures for the Main Wind-Force Resisting System (MWFRS) are calculated using the equation below, from ANSI/ASCE 7-95, Table 6-1:

$$p = q *(GC_p) - q_h *(GC_{pi})$$

where:

$q = q_z$ for windward wall at height Z above the ground

$q = q_h$ for leeward wall, side walls, and roof

$G = 0.85$ for Exposure C (sec. 6.6.1)

$C_p =$ values obtained from ANSI/ASCE 7-95, Figure 6-3

$(GC_{pi}) =$ values obtained from ANSI/ASCE 7-95, Table 6-4.

Note: When the wind is normal to the ridge, the windward roof experiences both positive and negative external pressures. Combining these external pressures with positive and negative internal pressures will result in four loading cases when wind is normal to the ridge. When wind is parallel to the ridge, positive and negative internal pressures result in two loading cases.

For Wall C_p from ANSI/ASCE 7-95, Figure 6-3, the pressure coefficients for the windward wall and for the side walls are 0.80 and -0.70, respectively, for all L/B ratios.

The leeward wall pressure coefficient is a function of the L/B ratio. When the wind is normal to the ridge, $L/B = 300/416 = 0.72$, therefore, the leeward wall pressure is -0.50. When the flow is parallel to the ridge, $L/B = 416/300 = 1.39$,

and corresponding to a value of C_p is -0.20. The wall pressure coefficients are summarized below:

<u>Wall C_p</u>			
<u>Surface</u>	<u>Wind Dir.</u>	<u>L/b</u>	<u>C_p</u>
Windward Wall	All	All	0.80
Leeward Wall	Normal to Ridge	0.72	-0.50
	Parallel to Ridge	1.39	-0.20
Side Wall	All	All	-0.70

Wind Normal to the 416 ft Face-Ridge

$$h/L = 24/300 = 0.10 < 0.50$$

Then: windward and leeward Roof $C_p = -0.50$ from $0 - h$

windward and leeward Roof $C_p = -0.50$ from $h - 2h$

windward and leeward Roof $C_p = -0.30$ from $>2h$

Internal GC_{pi} (ANSI/ASCE 7-95, Table 6-4)

The site is in a hurricane-prone region and has wind speeds equal to or greater than 110 mph. Positive Internal Pressure $GC_{pi} = +0.80$

Negative Internal Pressure $GC_{pi} = -0.30$

MWFRS Net Pressures

$$p = q *(GC_p) - q_h *(GC_{pi})$$

where:

$q = q_z$ for windward wall at height Z above the ground

$q = q_h$ for leeward wall, side walls, and roof

$$p = q * (0.85) * (C_p) - 47.0 * (+GC_{pi}) \quad +Ve \text{ Internal Pressure}$$

$$p = q * (0.85) * (C_p) - 47.0 * (-GC_{pi}) \quad -Ve \text{ Internal Pressure}$$

Typical Calculation: Windward Wall, 0 - 15 ft

Wind Normal to Ridge:

$$p = 42 * (0.85) * (0.8) - 47.0 * (+0.8) \quad +Ve \text{ Internal Pressure}$$

$$P = -9.04 \text{ psf, with +Ve Internal Pressure}$$

$$p = 42.0 * (0.85) * (0.80) - 47.0 * (-0.3) \quad +Ve \text{ Internal Pressure}$$

$$P = 43 \text{ psf, with -Ve Internal Pressure}$$

Typical Calculation: Roof, 0 - 25 ft from edge

Wind Normal to Ridge:

$$p = 47 * (0.85) * (-0.5) - 47.0 * (+0.8) \quad +Ve \text{ Internal Pressure}$$

$$P = -58.0 \text{ psf, with +Ve Internal Pressure}$$

$$p = 47.0 * (0.85) * (-0.5) - 47.0 * (-0.3) \quad +Ve \text{ Internal Pressure}$$

$$P = -6.0 \text{ psf, with -Ve Internal Pressure}$$

Net MWFRS Pressures: Wind Normal to Ridge

Surface	Height(z), ft	q _z , psf	C _p	Net Pressure, psf	
				(+GC _{pi})	(-GC _{pi})
Windward Wall	0-15	42.0	0.80	-9.04	43.0
Roof Height	24	47.0	0.80	-5.6	46.0
Leeward Wall	All	47.0	-0.50	-58.0	-6.0
Side Walls	All	47.0	-0.70	-65.0	-14.0
Windward and Leeward Roof	0-h*	47.0	-0.50	-58.0	-6.0
	h-2h*	47.0	-0.50	-58.0	-6.0
	>2h*	47.0	-0.30	-50.0	+2.0

* Distance from windward edge.

Wind Parallel to Ridge

$$\text{If } h/L = 32/400 = 0.08 < 0.50$$

then: windward and leeward Roof $C_p = -0.50$ from 0-h

windward and leeward Roof $C_p = -0.50$ from h-2h

windward and leeward Roof $C_p = -0.30$ from >2h

Internal GC_{pi} (ANSI/ASCE 7-95, Table 6-4)

The site is in a hurricane-prone region and has wind speeds equal to or greater than 110 mph. Positive Internal Pressure $GC_{pi} = +0.80$

Negative Internal Pressure $GC_{pi} = -0.30$

MWFRS Net Pressures

$$p = q *(GC_p) - q_h *(GC_{pi})$$

where:

$q = q_z$ for windward wall at height Z above the ground

$q = q_h$ for leeward wall, side walls, and roof

$p = q *(0.85)*(C_p) - 47.0*(+GC_{pi})$ +Ve Internal Pressure

$p = q *(0.85)*(C_p) - 47.0*(-GC_{pi})$ -Ve Internal Pressure

Typical Calculation: Windward Wall, 0 - 15 ft

Wind Parallel to Ridge:

$$p = 42*(0.85)*(0.8) - 47.0*(+0.8) \quad +\text{Ve Internal Pressure}$$

$P = -9.04$ psf, with +Ve Internal Pressure

$$p = 42.0*(0.85)*(0.80) - 47.0*(-0.3) \quad +\text{Ve Internal Pressure}$$

$P = 43$ psf, with -Ve Internal Pressure

Typical Calculation: Roof, 0 – 25 ft from edge

Wind Parallel to Ridge:

$$p = 47*(0.85)*(-0.5) - 47.0*(+0.8) \quad +\text{Ve Internal Pressure}$$

$$P = -58.0 \text{ psf, with } +\text{Ve Internal Pressure}$$

$$p = 47.0*(0.85)*(-0.5) - 47.0*(-0.3) \quad +\text{Ve Internal Pressure}$$

$$P = -6.0 \text{ psf, with } -\text{Ve Internal Pressure}$$

Net MWFRS Pressures: Wind Parallel to Ridge

Surface	Height(z), ft	q _z , psf	C _p	Net Pressure, psf	
				(+GC _{pl})	(-GC _{pl})
Windward Wall	0-15	42.0	0.80	-9.04	43.0
Roof Height	24	47.0	0.80	-5.6	46.0
Leeward Wall	All	47.0	-0.20	-46.0	-6.0
Side Walls	All	47.0	-0.70	-65.0	-14.0
Windward and Leeward Roof	0-h*	47.0	-0.50	-58.0	-6.0
	h-2h*	47.0	-0.50	-58.0	-6.0
	>2h*	47.0	-0.30	-50.0	+2.0

* Distance from windward edge.

See Figure 10 for a summary of the wind pressure loads on the Areas B, C, and D.

5 Analytical Modeling and Results

Modeling and Analysis for Area A

The model for a typical truss in Area A is shown in Figure 1 (Chapter 2). This model was subjected to two load combinations:

- Load Combination 1 = Dead Load + Live Load + Point Load
- Load Combination 2 = Dead Load + Point Load + Wind Load

The dead, live, point, and wind loads are described in Chapter 3. Using the SAP90 commercial software program*, the forces and moments were obtained. The SAP90 input and output files are shown in Appendix E. To obtain accurate results, the model was assumed to have rigid joints when three or four bolts were present. Joints with one or two bolts were considered as pinned. The connections of columns to the foundation were assumed to be rigid with a 6 in. long fictitious element at the end with a 50% area reduction to act as a spring release, as recommended in Issa and Al-Chaar (1998).

Table F1 (in Appendix F) is a list of all members as labeled in Figure 1. These labels were used for inspection and as numbered for the SAP90 computer model. The corresponding section properties are also listed in Table F1. The reaction for each load type was keyed into a spreadsheet and converted into a stress, as shown in Tables F2, F3, F4, and F5. The stresses due to Load Combination 1 and Load Combination 2 are summarized in Table F6. The allowable stresses resulted from the laboratory tests and the unadjusted NDS allowable stresses are listed in Table F7. The allowable stresses with the appropriate adjustment factors were computed and are presented in Tables F8 and F9. The interaction factors as described NDS code equations Eq 3.9-1, 3.9-2, and 3.9-3 are summarized in Tables F10 and F11 for stress interaction based on NDS adjusted

* Computers & Structures, Inc., Berkeley, CA.

allowable and laboratory test unadjusted allowable stresses. Finally, connections were checked. Results are summarized in Table F12.

Based on the NDS allowable stresses, the maximum interaction factors were 0.664 for member UT and 0.513 for member NO, for Load Combination 1 and Load Combination 2, respectively. The maximum interaction factors based on the allowable stresses obtained from laboratory tests were 0.704 for member UT and 0.478 for columns, for Load Combination 1 and Load Combination 2, respectively. The analysis revealed that the most stressed members in the model in descending order, were UT, TS, NO, SR, and NP. See Table F11 for details. Due to the symmetry of the model and lateral load reversal on the model, interaction on any member holds true for its mirror image member with respect to line of symmetry. See Figure 11 for location of most stressed members in Area A.

Modeling and Analysis for Area B

The model for a typical truss in Area B is shown in Figure 3 (Chapter 2). This model was subjected to two load combinations:

- Load Combination 1 = Dead Load + Live Load + Point Load
- Load Combination 2 = Dead Load + Point Load + Wind Load

The dead, live, point, and wind loads are described in Chapter 3. Using the SAP90 commercial software program, the forces and moments were obtained. The SAP90 input and output files are shown in Appendix E. To obtain accurate results, the model was assumed to have rigid joints when two or more bolts were present. Joints with one bolt were considered as pinned. The connections of columns to the foundation were assumed to be rigid with a 4 in. long fictitious member at the end with a 50% area reduction to act as a spring release (Issa and Al-Chaar 1998).

Table G1 in Appendix G contains a list of all members as labeled in Figure 3, used for inspection and as numbered for the SAP90 computer model. The corresponding section properties are also listed in Table G1. The reaction for each load type was keyed into a spreadsheet and converted into a stress, as shown in Tables G2, G3, G4, and G5. The stresses due to Load Combination 1 and Load Combination 2 are summarized in Table G6. The allowable stresses resulted from the laboratory tests and the unadjusted NDS allowable stresses are listed in Table G7. The allowable stresses with the appropriate adjustment factors were computed and are presented in Tables G8 and G9. The interaction

factors as described NDS code, equations Eq 3.9-1, 3.9-2, and 3.9-3 are summarized in Tables G10 and G11 for stress interaction based on NDS adjusted allowable and laboratory test unadjusted allowable stresses. Finally, connections were checked. Results are summarized in Table G12.

Based on the NDS allowable stresses, the maximum interaction factors were 0.501 and 0.598 for the columns, corresponding to Load Combination 1 and Load Combination 2, respectively. The maximum interaction factors based on the allowable stresses obtained from laboratory tests were 0.539 for member QP and 0.811 for columns, corresponding to Load Combination 1 and Load Combination 2, respectively. This analysis reveals that the most stressed members in the model are, in descending order, columns QP, PO, and VX. See Table F12 for details. Due to the symmetry of the model and lateral load reversal on the model, interaction on any member holds true for its mirror image member with respect to line of symmetry. See Figures 12 and 13 for most stressed members in Areas B, C, and D. Figure 14 shows typical trusses in Areas B, C, and D.

Modeling and Analysis for Areas C and D

The model for a typical truss in Areas C and D is shown in Figure 4 (Chapter 2). This model was subjected to two load combinations:

- Load Combination 1 = Dead Load + Live Load + Point Load
- Load Combination 2 = Dead Load + Point Load + Wind Load

The dead, live, point, and wind loads are described in Chapter 3. Using the SAP90 commercial software program, the forces and moments were obtained. The SAP90 input and output files are shown in Appendix E. To obtain accurate results, the model was assumed to have rigid joints when two or more bolts were present. Joints with one or two bolts were treated as pinned connections. The connections of columns to the foundation are assumed to be rigid with a 4 in. long fictitious member at the end with a 50% area reduction to act as a spring release (Issa and Al-Chaar 1998).

Table H1 (Appendix H) is a list of all members as labeled in Figure 4 (Chapter 2), as used for inspection and as numbered for the SAP90 computer model. The corresponding section properties are also listed in Table H1. The reaction for each load type was keyed in a spreadsheet and converted into a stress, as shown in Tables H2, H3, H4, and H5. The stresses due to Load Combination 1 and Load Combination 2 are summarized in Table H6. The allowable stresses resulted from the laboratory tests and the unadjusted NDS allowable stresses

are listed in Table H7. The allowable stresses with the appropriate adjustment factors were computed and are presented in Tables H8 and H9. The interaction factors as described NDS code equations, Eq 3.9-1, 3.9-2, and 3.9-3 are summarized in Tables H10 and H11 for stress interaction based on NDS adjusted allowable and laboratory test unadjusted allowable stresses. Finally, connections were checked and the results are summarized in Table H12.

Based on the NDS allowable stresses, the maximum interaction factors were 0.666 for member SR and 0.496 for columns, corresponding to Load Combination 1 and Load Combination 2, respectively. The maximum interaction factors based on the allowable stresses obtained from laboratory tests were 0.724 for member SR and 0.574 for columns, corresponding to Load Combination 1 and Load Combination 2, respectively. These analyses reveal that the most stressed members in the model, in descending order, are the SR, RQ, QP members and the NO columns. Due to the symmetry of the model and reversal of lateral load on the model, interaction in any member holds true for its mirror image member with respect to line of symmetry.

6 Retrofit and Repair Schemes

Recommended Retrofit and Repair in Area A

Proposed Solution for General Deficiencies Discussed in Chapter 2

Item 1: Self-explanatory; bolt-tightening solution is provided in same item.

Item 2: Protection for columns along column line M is recommended, as presented in Figure I1 (Appendix I).

Item 3: Repair by a professional roofer is recommended.

Item 4: Figures I2-1 and I2-2 present adding vertical braces for two bays along column line M.

Proposed Solution for Specific Deficiencies Discussed in Chapter 2

A detailed section of a typical truss in Area A is shown in Figure I3. This figure shows six types of joints labeled J1 through J6, member sizes, splice locations, and overall dimensions.

Item 1: The maximum interaction values obtained from analysis were presented in Chapter 5. These values indicate that there is a significant margin of safety in all problem members having a large split deficiency code identified during inspection of Building A.

Item 2: Self-explanatory; close monitoring is recommended in the same item.

Item 3: The recommended repairs are presented in Figures I4, I5, I6, I7, I8, and I9.

Item 4: The recommended repairs are presented in Figures I10 and I11.

Item 5: The maximum interaction values obtained from analysis were presented in Chapter 5. These values indicate that there is a significant margin of safety

in all problem members having a D deficiency code (except for decay of Joint B in Truss 24.5).

Item 6: The recommendation to repair Joint B in Truss 24.5 is presented in Figure I12.

Item 7: Repairs recommended for fractured diagonal members are shown in Figures I13 and I14. The repair technique proposed in I13 is more effective; the proposed repair in Figure I14 may be used on members with constructibility problems. See Photo 36 for an existing repair application that may be used to repair newly damaged diagonal members in Area A.

Item 8: It is recommended that the ends of cantilever supports be connected directly to purlins spanning the truss under consideration and the adjacent truss.

Recommended Retrofit and Repair in Areas B, C, and D

Proposed Solution for General Deficiencies Discussed in Chapter 2

Item 1: Tighten bolts as recommended in the inspection notes.

Item 2: Repair by a professional roofer is recommended.

Item 3: An appropriate increase in repainting frequency is recommended to control the paint deterioration noted in the inspection.

Proposed Solution for Specific Deficiencies Discussed in Chapter 2

Item 1: The maximum interaction values obtained from analysis were presented in Chapter 5. The values, based on allowable stresses from laboratory tests, indicate a significant margin of safety, except for QR, RS, and ST members. Other than these exceptions, members identified during the inspection with an Ls deficiency code are structurally adequate. Repair of a split member ST in Truss 46 of Area D is recommended. The proposed repair can be accomplished by attaching a 3/8 in. x 5 in. x 11 ft steel plate to each side of the chord between joints T and R.

Item 2: Inspection results were provided for documentation only; the affected areas should be monitored closely during the next inspection.

Item 3: End-splits should be repaired by stitch-bolt techniques: one bolt on each side for compression members, and one bolt on the end of tension members.

Item 4: No split was found so no repair is necessary.

Item 5: The maximum interaction values obtained from analysis were presented in Chapter 5. The values, based on allowable stresses from laboratory tests, indicated a significant margin of safety, except for QR, RS, and ST members. Other than these exceptions, members identified with a D deficiency code, are structurally adequate. Repairs for decayed ST members in Truss 51, and QR and RS members in Trusses 49 and 51 of Area D shall be made by applying a 3/8 in. x 5 in. x 11 ft steel plate on each side of the chord between joints Q and S.

Item 6: Purlins may be replaced with identical or stronger wood purlins; alternatively, comparable standard steel beams may be used.

Item 7: Replace knee braces as described.

Item 8: The east face of the Column C63 has been severely damaged by termites. Replacement of the damaged face is recommended.

Item 9: Protect the column from moisture released from the sink, as suggested in the inspection notes in Chapter 2.

Item 10: Repair fractured top chord as shown in Figure I15.

Item 11: Repair fractured bottom chord as shown in Figure I16.

Item 12: For fractured diagonal CT member in Truss 63 of Area B, the use of a typical tension rod is recommended.

General Retrofit Structural Notes

1. The contractor shall provide adequate bracing as required for the stability of the structure during all phases of retrofit/construction.
2. Structural steel shall conform to ASTM-A36, unless otherwise noted.
3. High-strength bolts shall conform to ASTM-A325. The nuts shall be heavy Hex., Grade C, conforming to ASTM-A563.
4. Tighten bolts sufficiently to close split, but avoid crushing wood fibers.
5. All workmanship and material shall conform to the latest edition of the NDS specification.

6. All workmanship and material shall conform to the latest edition of the American Institute of Steel Construction (AISC) specification (9th ed.) for the design of the structural components.
7. All welding shall be done by the shielded arc process using approved electrodes per the latest edition of the Structural Welding Code by the American Welding Society (AWS).
8. For all stitch bolts in Figures I4 – I11, provide 3 x 3 x 3/8 in. steel plate washers under the bolt heads and the nuts.
9. All welding shall be in accordance with the latest edition of the AWS Structural Welding Code.

7 Conclusions

The loading combinations used in this analysis included a wind speed of 130 mph to account for the facility's location in a hurricane-prone region. However, wind forces did not govern the results due to low exposure of the structures to such loading. The combination of dead, live, and point loads exceeded the combined stresses resulting from dead, point, and wind loading.

Laboratory tests to determine the allowable stresses yielded higher allowable stresses than the NDS Standard did. These allowable stresses from laboratory tests resulted in unconservative but accurate interaction values. Based on the laboratory tests allowable stresses and the NDS allowable stresses, most members were concluded to be adequate.

Several members did not meet inspection requirements. They were grouped and retrofit schemes for each group were proposed. Some of these schemes are identical to existing repair techniques and can be applied with identical details.

Joint interactions have exceeded the allowable interaction of 1.0 in case of Joint J5 and Load Combination 1. It is recommended that the design point load be reduced from 3000 lb to 2000 lb per joint at bottom chords in Area A. For Areas B, C, and D a point load of 1000 lb was assumed for each joint of the bottom chords of all trusses. This assumption has yielded conservative values of joint interactions. Consequently, it is recommended to reduce the allowable point loads on each joint of the lower chord of each truss from 1000 lb to 500 lb.

Table 1. Inspected areas in Building 8.

Area	Name	Column lines	Size (sq ft)
A	Small Hangar	I-M & 22-38	400 x 100 = 40,000
B	Engine Cleaning	A-I & 38-64	416 x 200 = 83,200
C	Engine Disassy & Repair	A-BB & 45-64	304 x 50 = 15,200
D	Engine Disassy & Repair	BB-DD & 45-64	304 x 50 = 15,200

Table 2: Deficiency codes used in inspection forms of Appendices A, B, C, and D.

<p>Letter:</p> <p>T: Tension C: Compression H: Horizontal Chord V: Vertical Chord D: Diagonal Chord</p> <p>Definition of Inspection Codes:</p> <p>Ls (Large split): Recommendation for repair will be based on the degree of stresses computed in the detailed analysis. Only members with interaction stress greater than 0.75 will be suggested for repair. Usually a split greater than 1/16 in. is classified with Ls code. See Photo 5 for an example of member with large split.</p> <p>Ss (Small split): These splits are reported to be closely monitored during the next inspection period. Usually a split less than 1/16 in. is classified as Ss. See Photo 6 for an example of member with a small split.</p> <p>Es (End split): Any split in the end of members at the joint is classified as Es. Recommended repair is to apply a stitch bolt as shown in Figure 3. See Photo 7 for an example of member with an end split.</p> <p>Bsc (Splice split): Any split in a splice connecting two members is classified as Bsc. Recommended repair is to apply a stitch bolt as shown in Figures I10 and I11</p> <p>R (Repaired member): Already repaired member. These data will be used in analysis as needed, if the perspective member is over stressed. See Photos 3 and 4 for examples of a repair in Area A.</p> <p>D (Decayed member): Recommendation for repair will be based on the degree of stresses computed in the detailed analysis. See Photos 8 and 9 for an example of a decayed member. An engineering judgement will be exercised to estimate strength reduction based on the degree of decay in the damaged member.</p> <p>T (Termite damage): Full or partial replacement of member is required. See Photo 23 for an example of member damaged by termites that are no longer active.</p>

Table 3. Number of deficiencies reported during inspection of Area A.*

Member	T/C	H/V/D	# of Ls	# of Ss	# of R	# of Es	# of Bsc	# of D
AB	C	V	26	1	3	16		5
BC	C	H	5	6		6		1
CD	C	H	4	2		3	3	1
DE	C	H	5	3		2		
EF	C	H		2			3	
FG	C	H	3	3				
GH	C	H	2	2		1		
HI	C	H		1		2		
IJ	C	H	1					
JK	C	H		3			2	2
KL	C	H	3	7		2		1
LM	C	H		1		1	1	2
MN	C	H	2	6		8		1
NO	C	V	20	2	1	10		2
OP	T	H		1		1		
PQ	T	H		1				
QR	T	H		5				
RS	T	H		12				
ST	T	H		4				
TU	T	H		3				
UV	T	H		8		1		
VW	T	H		2			3	
WX	T	H	1	4		1		
XY	T	H	1	2				
YZ	T	H	2	3		2	1	1
ZA	T	H	1					
BZ	T	D	7	9		27		6
ZC	C	V	9	13	6	5		
CY	T	D	4	8	1	4		4
YD	C	V	3	11	7	4		
DX	T	D	1	1	2	2		
XE	C	V	3	5	5	1		
EW	T	D				1		
WF	C	V	1	4	3	1		1
FV	T	D	1					1
VG	C	V	7	10	7			
GU	T	D	1					
UH	C	V	11	7	7	2		
UI	T	D						
IT	C	V	5	2	1	1		
TJ	T	D		2				2
JS	C	V		1	4	1		
SK	T	D	1	2		2		2
KR	C	V	1	1	4			
RL	T	D			1	1		
LQ	C	V	1	5	9			
QM	T	D		2		5		4
MP	C	V	5	4	11	1		1
PN	T	D	4	5		21		
Total			141	176	72	**135	13	37

* See Table 2 and Appendix A for the use and definition of codes

** 80 accessible end splits and 55 unaccessible end splits

Table 4. Number of Deficiencies Reported During Inspection of Area B.*

Member	T/C	H/V/D	# of Ls	# of Ss	# of R	# of Es	# of Bsc	# of D
BC	C	V	2	3				
CD	C	H	1	1				
DE	C	H	1	2				
EF	C	H	1	2				
FG	C	H	1	4				
GH	C	H	1	5				1
HI	C	H		6				1
IJ	C	H		3	1			2
JK	C	H	1	4	1			1
KL	C	V	1	2	3			1
LN	T	H		4	2			1
NO	T	H		6	1			3
OP	T	H		3	1			3
PQ	T	H	1	1	1			1
QR	T	H		3	1			1
RS	T	H		8				4
ST	T	H	1	9				4
TB	T	H	1	4		1		3
CT	T	D	2	14	1	13		1
TD	C	V	3	9	3	1		1
DS	T	D	1	16	4	10		1
SE	C	V	5	13	2	4		1
ER	T	D	2	11	7	7		4
RF	C	V	6	13	2	1		1
FQ	T	D	2	8	1	3		6
QG	C	V	6	5	1	9		1
QH	T	D	2	18	2	5		3
HP	T	V		15		8		1
PI	T	D	6	8	9	3		4
IO	C	V	3	7	3	16		
OJ	T	D	4	10	6	7		1
JN	C	V		4	3	8		
NK	T	D	7	6	3	12		
Total			61	227	58	108**	0	51

* For Code definition and use see table 2 and Appendix B

** 88 accessible end splits and 20 inaccessible end splits

Table 5. Number of deficiencies reported during inspection of Area C.*

Member	T/C	H/V/D	# of Ls	# of Ss	# of R	# of Es	# of Bsc	# of D
BC	C	V						
CD	C	H		1				
DE	C	H		1				
EF	C	H		1				
FG	C	H		1				
GH	C	H		2				1
HI	C	H		1				
IJ	C	H		1				
JK	C	H	1	1				
KL	C	H	1	1				
LM	C	H		1				
MN	C	V		1				
NO	T	H						
OP	T	H	2					
PQ	T	H	2					
QR	T	H	1					
RS	T	H						
ST	T	H						
TU	T	H						
UV	T	H						
VW	T	H						
WB	T	H						
BD	C	D		1		1		
DW	C	V	1	1		2		1
DV	T	D	1	1		3		
VE	C	V	1	3	1	1		
EU	T	D	1	3				
UF	C	V		3	1			
FT	T	D	1	1				
TG	C	V	2	3				
GS	T	D		3				
SH	C	V	2	3		1		
SI	T	D	2	6				
IR	C	V	2	2		1		
RJ	T	D	2	3				
JQ	C	V	1	1		2		
QK	T	D		2		2		
KP	C	V		2		2		
PL	T	D	1	2		3		
LO	C	V	3	1	1			
OM	T	D	2	4		6		
Total			29	57	3	24**	0	2

* For code definition and use see Table 2 and Appendix C

** 23 accessible end splits and 1 inaccessible end split

Table 6. Number of deficiencies reported during inspection of Area D.*

Member	T/C	H/V/D	# of Ls	# of Ss	# of R	# of Es	# of Bsc	# of D
BC	C	V	1	1				
CD	C	H		1				
DE	C	H						1
EF	C	H						1
FG	C	H						2
GH	C	H		1				1
HI	C	H		1				2
IJ	C	H						2
JK	C	H						2
KL	C	H						3
LM	C	H						2
MN	C	V						1
NO	T	H						3
OP	T	H						3
PQ	T	H						3
QR	T	H						2
RS	T	H						2
ST	T	H	1					1
TU	T	H						
UV	T	H						
VW	T	H						
WB	T	H						
CW	C	D		3		5		
DW	C	V		3		1		
DV	T	D	2	2		8		
VE	C	V	2	3		1		
EU	T	D		3		4		
UF	C	V		1				
FT	T	D		4		3		
TG	C	V						
GS	T	D		2		1		1
SH	C	V	5			2		
SI	T	D	1	2		1		1
IR	C	V	1	2				
RJ	T	D		2		1		
JQ	C	V		2		1		
QK	T	D		3		1		1
KP	C	V		3		1		
PL	T	D				2		1
LO	C	V		1				
OM	T	D		1		3		1
Total			13	41	0	35**	0	36

* For definition and use of codes see Table 2 and Appendix D

** 30 accessible end splits and 5 inaccessible end splits

Table 7. List of damaged purlins.

Area	Truss No.	Section	Purlins *
B	60	AC	G,H,I
B	61	EG	J
B	61	CEJ	E,F
B	61	AC	G,H,I
B	62	EG	G
B	62	AC	K,I
B	63	EG	G,F
B	63	AC	I,E
B	64	EG	F
B	64	AC	I,E
D	62	BB DD	F,J,L
D	63	BB DD	J

* Total 23 purlins.

Table 8. Southern Yellow Pine dimension lumber.

Code	Dimension	Weight (lb)	Specific Gravity ^a
A-1	2 1/2" x 7 1/8" x 16 3/8"	8.3	0.788
A-2	2 1/2" x 7 1/4" x 18 3/4"	9.2	0.749
A-3	2 1/2" x 7 1/4" x 37 3/4"	17.2	0.696
A-4	2 1/2" x 7 1/4" x 38"	19.3	0.776
A-5	1 1/2" x 5 3/8" x 34 1/4"	7.1	0.712
D-1	2 1/2" x 7 1/4" x 40"	14.3	0.546
D-2	2 1/4" x 7 1/4" x 21 5/8"	8.2	0.644
D-3	1 3/4" x 1 1/2" x 28 3/8" (Irregular shaped)		

^a Specific gravity is calculated based on air-dry weight and air-dry volume.

Table 9. Test specimens and methods.

Specimens	Size	No. of Tests		Testing Speed (Inch/Min).	ASTM (D-143)
		A	D		
Static Bending Stress	1" x 1" x 16"	10	7	0.05	Sec. 8.1-8.8
Tensile Stress	1" x 1" x 18"	10	9	0.05	Sec. 16.1-16.6
Horizontal Shear Stress	2" x 2" x 2 1/2"	17	10	0.024	Sec. 14.1-14.6
Compression Parallel to Grain	2" x 2" x 8"	10	10	0.024	Sec. 9.1-9.8
Compression Perpendicular to Grain	2" x 2" x 6"	10	10	0.012	Sec. 12.1-12.6

Table 10. Static bending test results.

Code	Moisture Content (%)	Specific Gravity	Maximum Bending Stress (Psi)	Modulus of Elasticity (Psi)
A 1-1	11.1	0.651 (11) ^b	17,000	1,911,000
A 1-2	9.2	0.808 (20)	21,400	2,646,000
A 1-3	10.2	0.637 (17)	16,520	2,303,000
A 1-4	10.2	0.673 (10)	19,680	2,058,000
A 5-1	12.9	0.635 (7)	14,200	1,419,300
A 5-2	10.4	0.608 (7)	15,120	2,216,300
A 5-3	10.1	0.608 (7)	14,800	1,715,000
A 5-4	10.2	0.565 (7)	14,900	1,715,000
A 5-5	---	0.554 (6)	14,400	1,029,000
A 5-6	9.9	0.554 (6)	11,870	1,543,500
Average	10.5	0.629 (9.8)	16,000	1,856,000
D 1-1	11.3	0.496 (7)	12,610	1,813,000
D 1-2	11.1	0.512 (7)	13,300	2,015,130
D 1-3	11.7	0.489 (8)	13,000	2,058,000
D 1-4	14.1	0.487 (7)	12,350	1,672,130
D 2-1	11.5	0.499 (7)	12,330	1,500,630
D 2-2	11.2	0.520 (7)	11,900	1,586,380
D 3-1	10.2	0.620 (4)	9,870	1,749,300
Average	11.6	0.518 (6.7)	12,200	1,770,650

^a Based on oven dry weight and air dry volume.

^b Rings per inch.

Table 11. Maximum tensile stress parallel to grain (average MC – 10.2%).

Code	Tensile Stress (Psi)	Ring/Inch	Failure Mode
A 2-1	17,400	18	Mid-Section
A 2-2	9,300	22	Neck Area
A 2-3	11,700	9	Mid-Section
A 2-4	13,400	10	Mid-Section
A 3-1	2,340	17	Holder Area
A 3-2	10,040	15	Neck Area
A 3-3	11,220	10	Neck Area
A 3-4	3,020	13	Ring Shake
A 3-5	9,100	11	Decayed Area
A 3-6	8,350	13	Mid-Section
Average	9,590	14	
D 1-1	17,870	18	Mid-Section
D 1-2	3,570	10	Neck Area
D 1-3	4,700	7	Decayed Area
D 1-4	10,430	9	Decayed Area
D 2-1	12,600	9	Decayed Area
D 2-2	5,040	7	Mid-Section
D 2-3	9,900	7	Mid-Section
D 2-4	8,220	13	Mid-Section
D 2-5	10,500	10	Mid-Section
Average	9,200	9	

Table 12. Maximum horizontal shear stress.

Code	Shear Stress(Psi)	Shear Modulus(Psi)	Rings/Inch	Grain Direction
A 1-1	2,110	120,000	17	Tangential
A 1-2	1,864	109,000	5	Tangential
A 3-1	1,481	9,550	22	Tangential
A 3-2	1,834	107,600	14	Radial
A 4-1	1,672	111,430	18	Tangential
A 4-2	1,503	100,000	18	Tangential
A 4-3	1,803	88,900	9	Radial
A 4-4	1,726	88,900	11	Radial
A 4-5	1,717	110,800	11	Radial
A 4-6	2,140	110,800	18	Tangential
A 4-7	1,683	140,250	18	Tangential
A 4-8	842	56,000	15	Tangential
A 4-9	1,286	116,900	8	Tangential
A 4-10	1,192	79,500	8	Radial
A 4-11	1,290	129,000	8	Tangential
A 4-12	1,280	85,300	10	Radial
A 4-13	1,590	117,800	10	Tangential
Average	1,589	98,930		
D 1-1	1,270	67,500	12	Tangential
D 1-2	1,445	75,000	15	Radial
D 1-3	1,031	84,460	9	Radial
D 1-4	1,013	77,942	8	Radial
D 1-5	1,225	64,900	9	Tangential
D 1-6	1,426	60,000	7	Tangential
D 1-7	1,283	60,000	10	Radial
D 1-8	1,209	63,160	10	Radial
D 1-9	1,425	72,730	10	Radial
D 2-1	1,439	68,000	9	Tangential
Average	1,307	69,390		

Table 13. Maximum compressive stress parallel to grain.

Code	Specific Gravity ^a	Stress at Proportional Limit (Psi)	Maximum Stress (Psi)	MOE (C) (Psi)
A 2-1	0.850 (12) ^b	6,000	9,600	1,600,000
A 2-2	0.806 (12)	6,000	9,286	1,600,000
A 3-1	0.720 (20)	7,500	9,418	1,818,000
A 3-2	0.649 (22)	6,000	8,711	1,777,800
A 3-3	0.667 (18)	7,800	9,844	1,835,500
A 3-4	0.650 (15)	7,500	8,998	1,818,200
A 3-5	0.648 (15)	5,100	8,310	1,600,000
A 3-6	0.772 (15)	6,000	10,270	1,600,000
A 3-7	0.780 (14)	6,000	10,461	1,600,000
A 3-8	0.754 (15)	6,000	9,553	1,454,600
Average	0.730 (16)	6,390	9,445	1,670,410
D 1-1	0.538 (7)	4,500	6,720	1,333,000
D 1-2	0.563 (7)	4,500	7,197	1,241,400
D 1-3	0.563 (7)	5,700	7,197	1,425,000
D 1-4	0.545 (8)	5,400	7,282	1,440,000
D 1-5	0.569 (8)	5,550	7,579	1,585,700
D 1-6	0.576 (7)	5,400	7,350	1,600,000
D 1-7	0.576 (8)	5,875	7,640	1,468,750
D 1-8	0.555 (8)	4,500	6,704	1,200,000
D 2-1	0.630 (8)	4,200	6,123	960,000
D 2-2	0.578 (8)	5,400	7,000	1,440,000
Average	0.569 (7.6)	5,125	7,480	1,376,860

^a Based on oven dry weight and air dry volume.^b Rings per inch.**Table 14. Compression perpendicular to grain.**

Code	Specific Gravity ^a	Compressive Stress at Proportional Limit (Psi)	MOE (C _⊥) (Psi)
A 1-1	0.797 (13) ^b	2,100 (2,487) ^c	127,270
A 1-2	0.782 (18)	1,500 (2,513)	75,000
A 1-3	0.650 (12)	1,020 (1,482)	70,350
A 1-4	0.640 (12)	2,160 (2,719)	88,170
A 2-1	0.633 (20)	1,800 (2,288)	94,740
A 2-2	0.670 (12)	1,500 (2,010)	111,100
A 4-1	0.655 (16)	1,200 (1,603)	81,600
A 4-2	0.648 (16)	1,800 (2,250)	109,100
A 4-3	0.664 (18)	1,200 (1,821)	96,000
A 4-4	0.660 (Estimated)	1,200 (1,699)	80,000
Average	0.680 (15)	1,548 (2,087)	93,330
D 1-1	0.485 (7)	840 (1,356)	62,000
D 1-2	0.504 (9)	900 (1,187)	51,430
D 1-3	0.538 (7)	1,020 (1,265)	75,600
D 1-4	0.563 (7)	1,031 (1,200)	82,460
D 1-5	0.563 (7)	840 (1,247)	67,200
D 1-6	0.545 (8)	660 (1,243)	88,000
D 1-7	0.569 (8)	690 (1,141)	55,200
D 1-8	0.576 (7)	600 (1,187)	45,000
D 2-1	0.630 (8)	900 (1,263)	47,400
D 2-2	0.578 (8)	720 (1,565)	65,450
Average	0.555 (7.6)	820 (1,265)	63,970

^a Based on oven dry weight and air dry volume.^b Rings per inch.^c Stress at 0.100 inches deformation.

Table 15. Average tested properties (psi) of Southern Yellow Pine.

Property	Sample A	Sample D	Wood Handbook Values ¹
F _b (Bending)	16,000 (11,870-21,400) ²	12,200 (9,870-13,300)	14,050 (12,800-15,900)
C ₁₁ (Compression Parallel)	9,445 (8,310-10,461)	7,480 (6,123-7,640)	5,585 (4,820-6,280)
F _v (Shear)	1,589 (842-2,140) ²	1,307 (1,013-1,445)	1,477 (1,310-1,730)
F _t (Tension)	9,590 (2,340-13,400)	9,200 3,570-17,870	7,922 (7,070-9,100)
E (MOE)	1,856,000 (1,029,000-2,646,000)	1,770,650 (1,500,000-2,058,000)	1,900,000 1,760,000-2,060,000)
C ₁ (Compression Perpendicular)	1,548 (1,020-2,180)	820 (600-1,031)	1,140 (980-1,390)

¹ Reference No. 6.

² Minimum and maximum values.

Table 16. Average allowable strength properties for Southern Pine sample A.

Property	Tested Dry (Psi)	Adjustment Factor ¹	Strength Ratio ¹ (DSS grade)	Allowable Property (Psi)	Book Design Value (Psi) ²	
					Dense Select Structural (DSS)	No. 1 Dense Grade
F _b (Bending)	16,000	1/2.1	0.67	5,100	2,450	1,650
C ₁₁ (Compression)	9,445	1/1.9	0.78	3,875	2,050	1,800
F _v (Shear)	1,589	1/4.1	0.50	190	90	90
F _t (Tension)	9,590	1/2.1	0.37	1,690	1,350	875
E (MOE)	1,856,000	1/0.94	1.00	1,975,000	1,900,000	1,800,000
C ₁ (Compression Perpendicular)	1,548	1/1.67	1.00	925	660	660

¹ See reference No. 3.

² See reference Nos. 1 and 5.

Table 17. Average allowable strength properties for Southern Pine sample D.

Property	Tested Dry (Psi)	Adjustment Factor ¹	Strength Ratio ¹ (NDSS grade)	Allowable Property (Psi)	Book Design Value (Psi) ²	
					Non-Dense Select Structural (NDSS)	No. 1 Non-Dense Grade
F _b (Bending)	12,200	1/2.1	0.55	3,195	2,100	1,350
C ₁₁ (Compression)	7,480	1/1.9	0.62	2,440	1,750	1,550
F _v (Shear)	1,307	1/4.1	0.50	159	90	90
F _t (Tension)	9,200	1/2.1	0.31	1,355	1,100	725
E (MOE)	1,770,650	1/0.94	1.00	1,883,000	1,700,000	1,600,000
C ₁ (Compression Perpendicular)	820	1/1.67	1.00	490	480	480

¹ See reference No. 3.

² See reference Nos. 1 and 5.

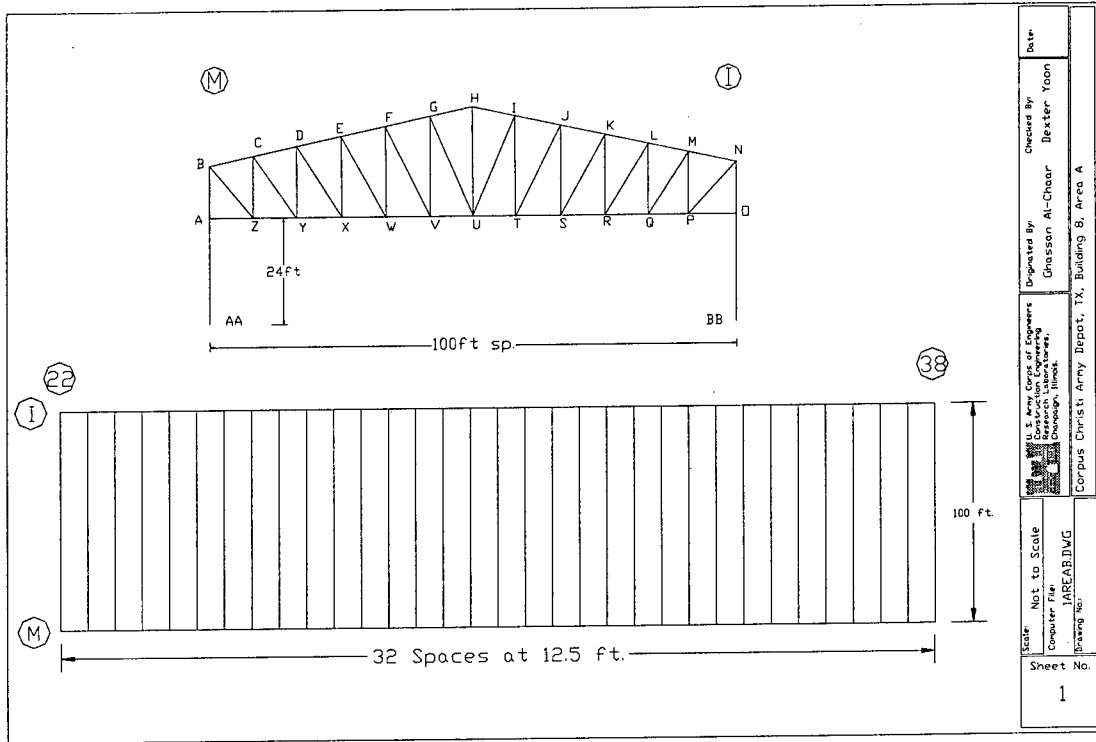

Figure 1. Plan view and typical truss in Area A.

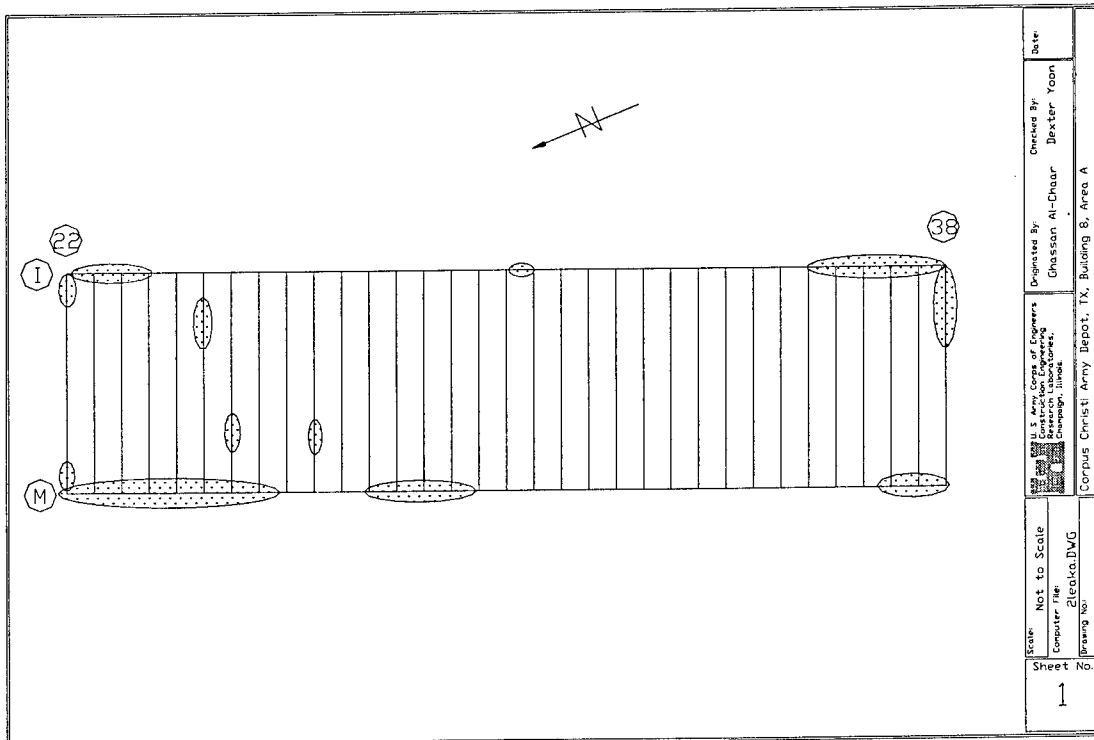

Figure 2. Location of leak traces and roof surfaces collecting water in Area A.

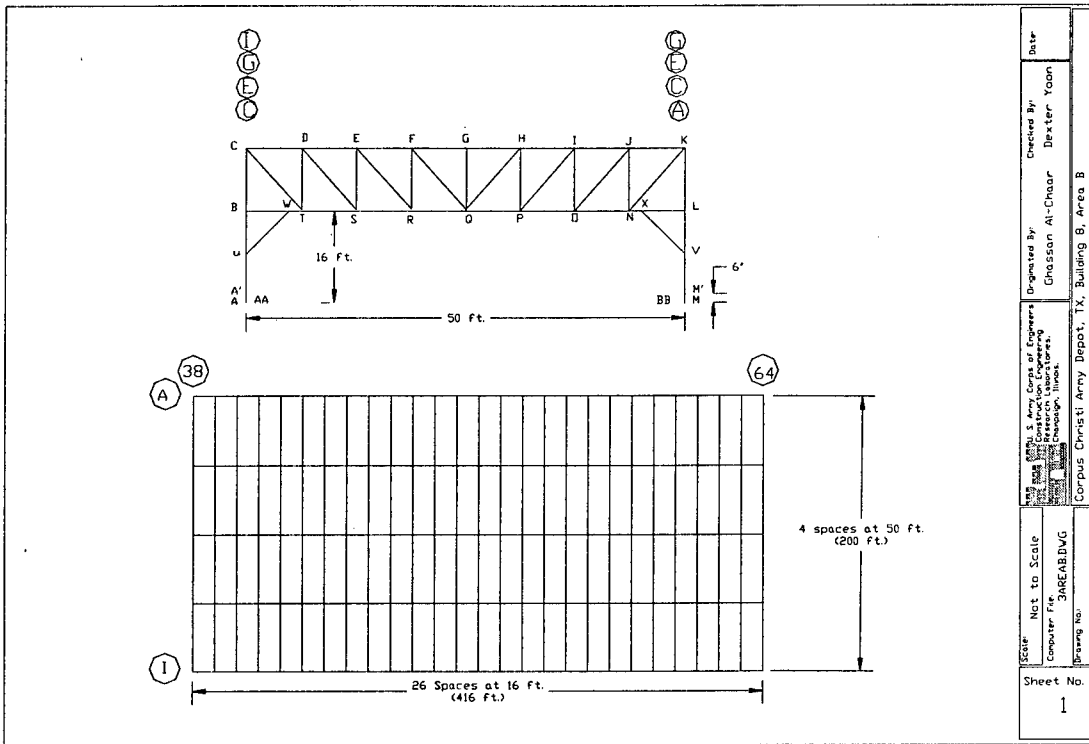

Figure 3. Plan view and typical truss in Area B.

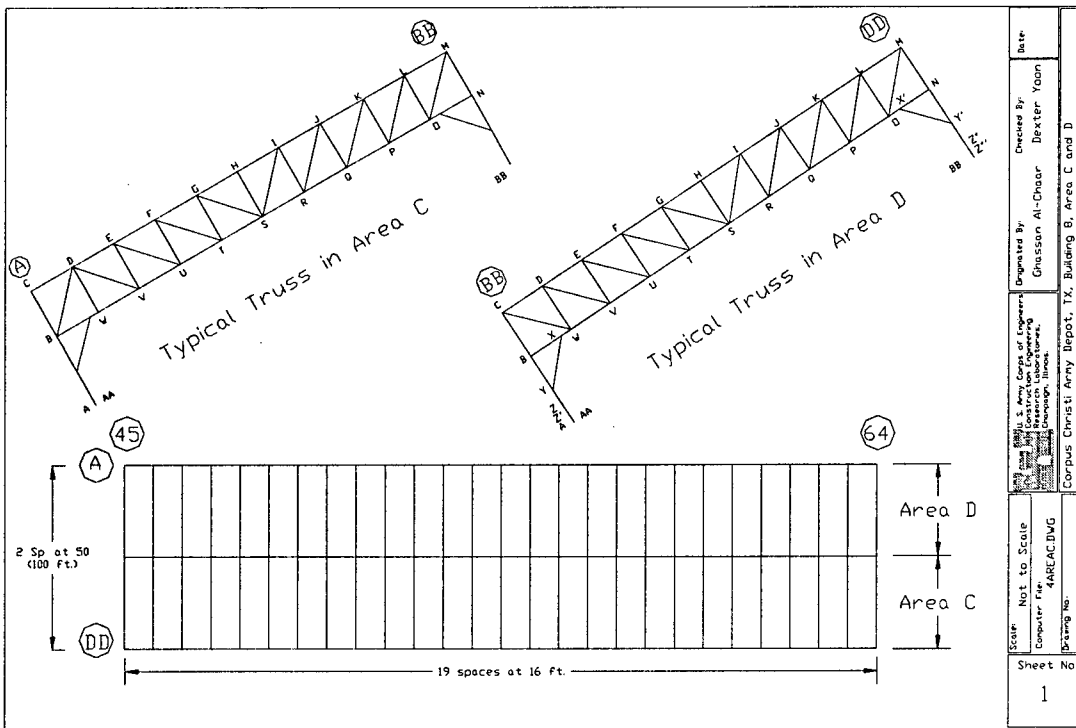

Figure 4. Plan view and typical trusses in Areas C and D.

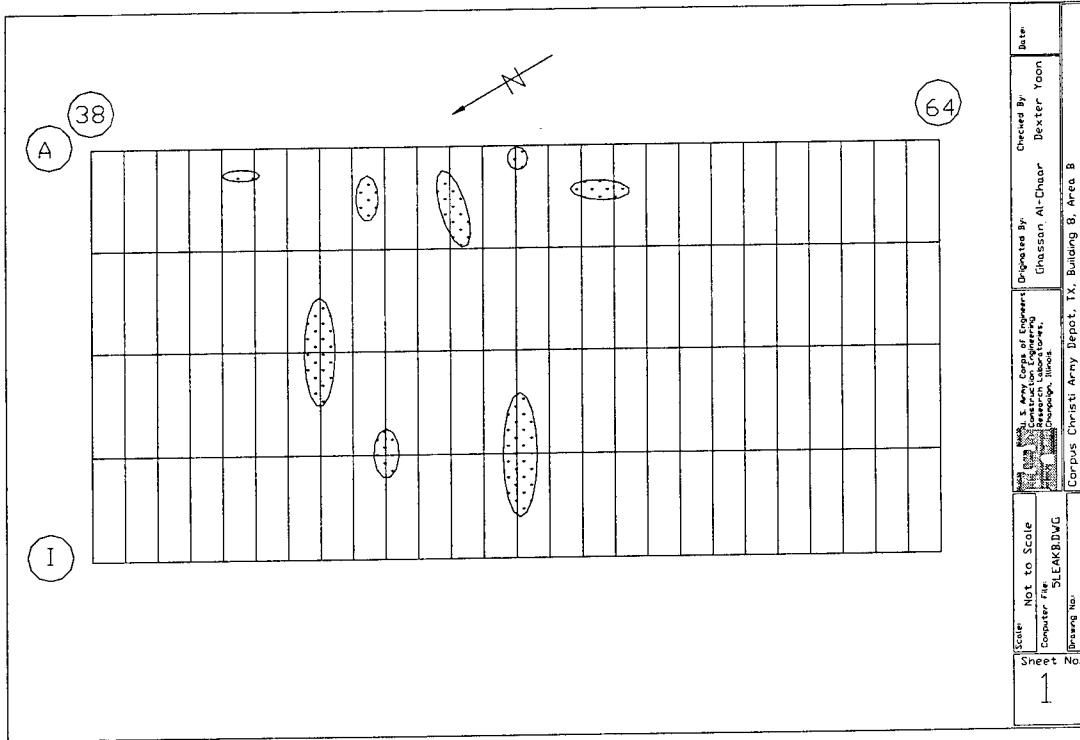

Figure 5. Location of leak traces and roof surfaces collecting water in Area B.

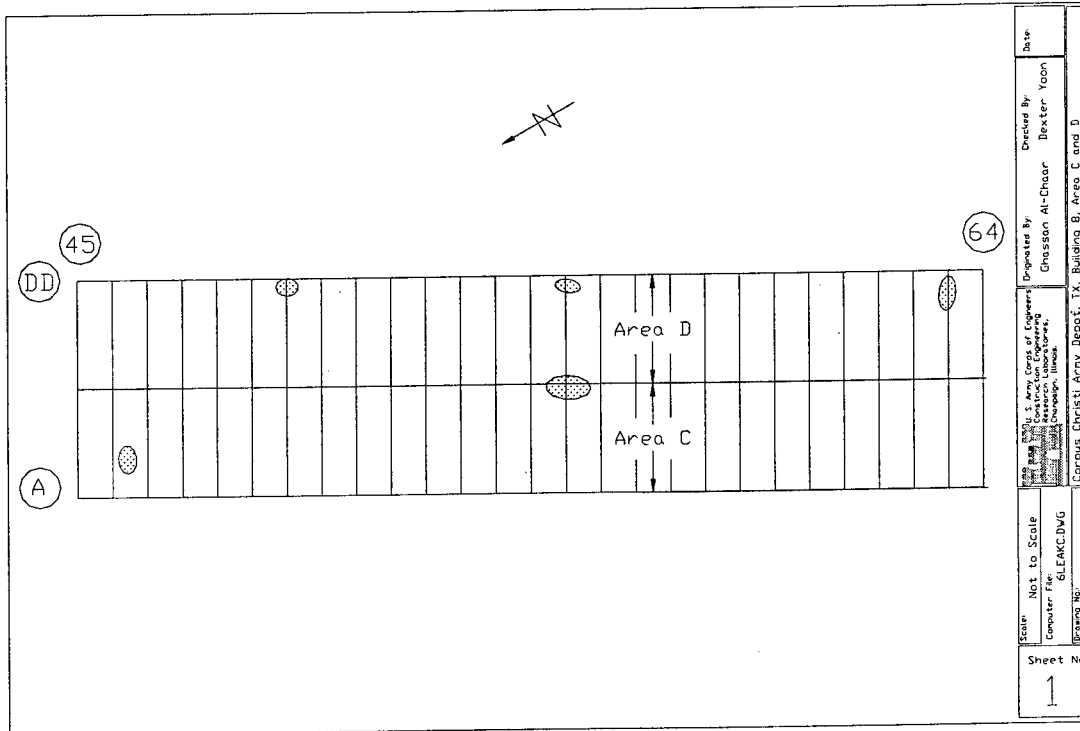

Figure 6. Location of leak traces and roof surfaces collecting water in Areas C and D.

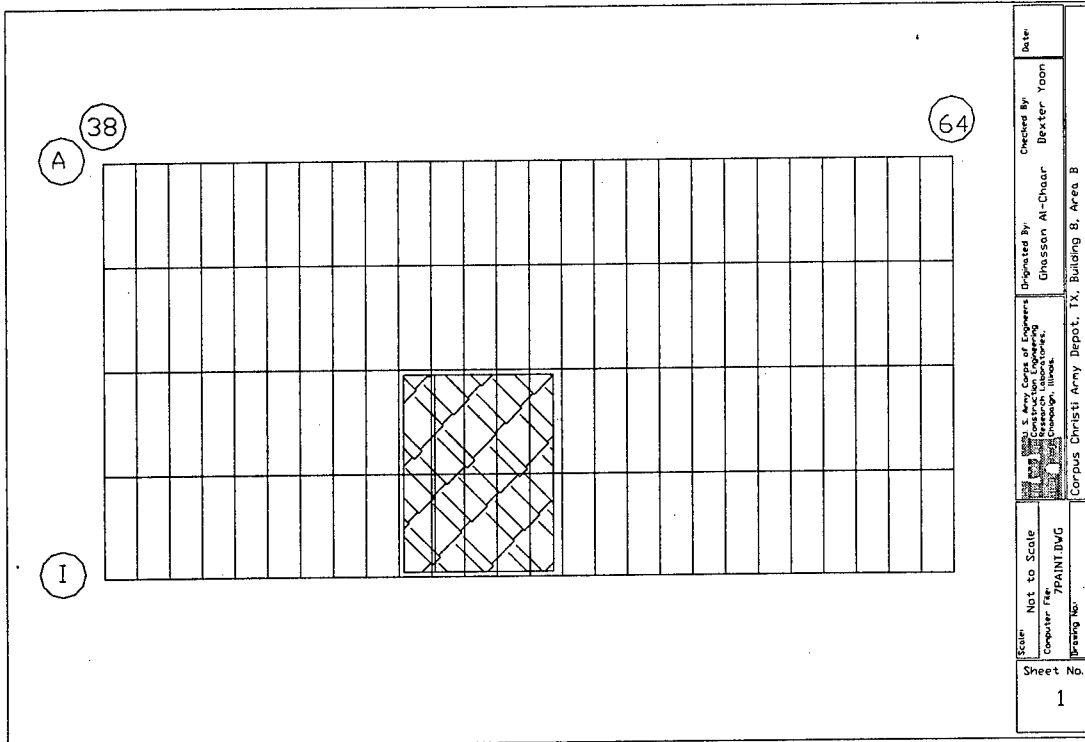

Figure 7. Location of heavy paint peeling from chemicals in Area B.

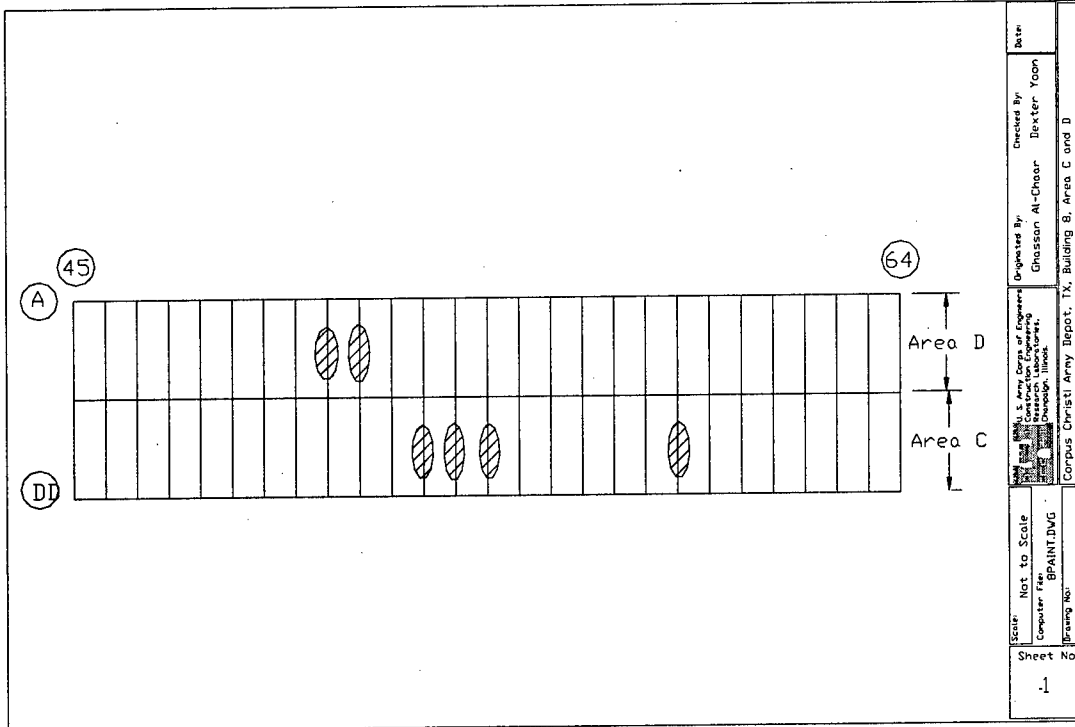

Figure 8. Location of non-chemical paint peeling in Areas C and D.

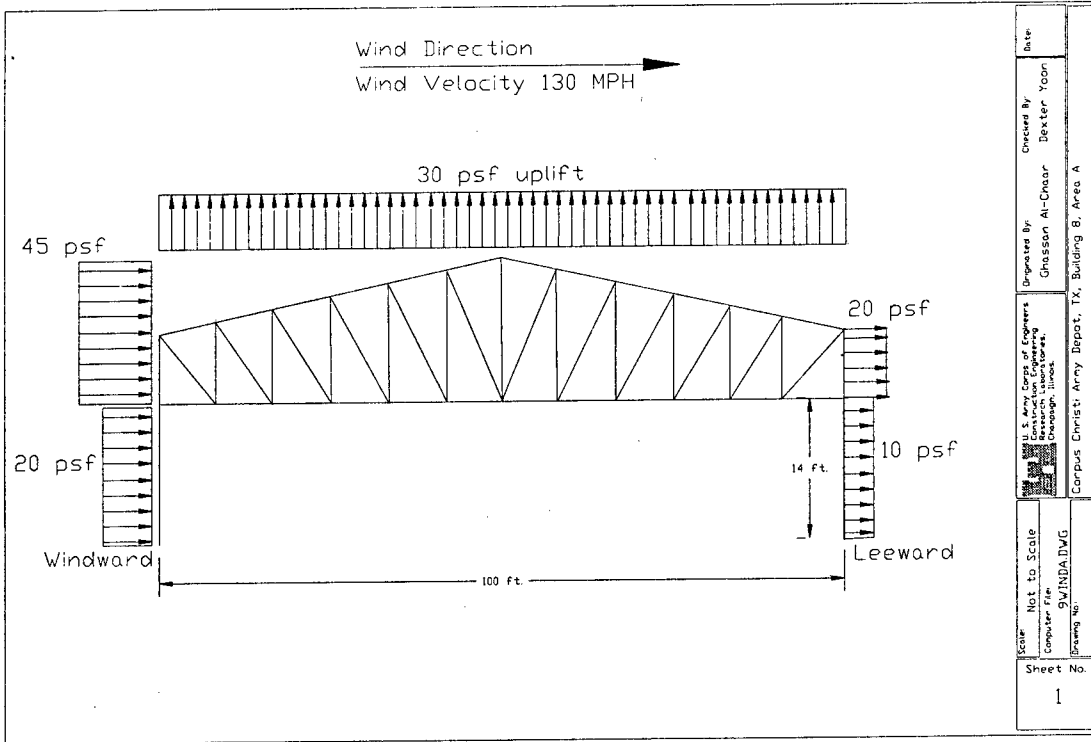

Figure 9. Wind pressure distribution on Area A.

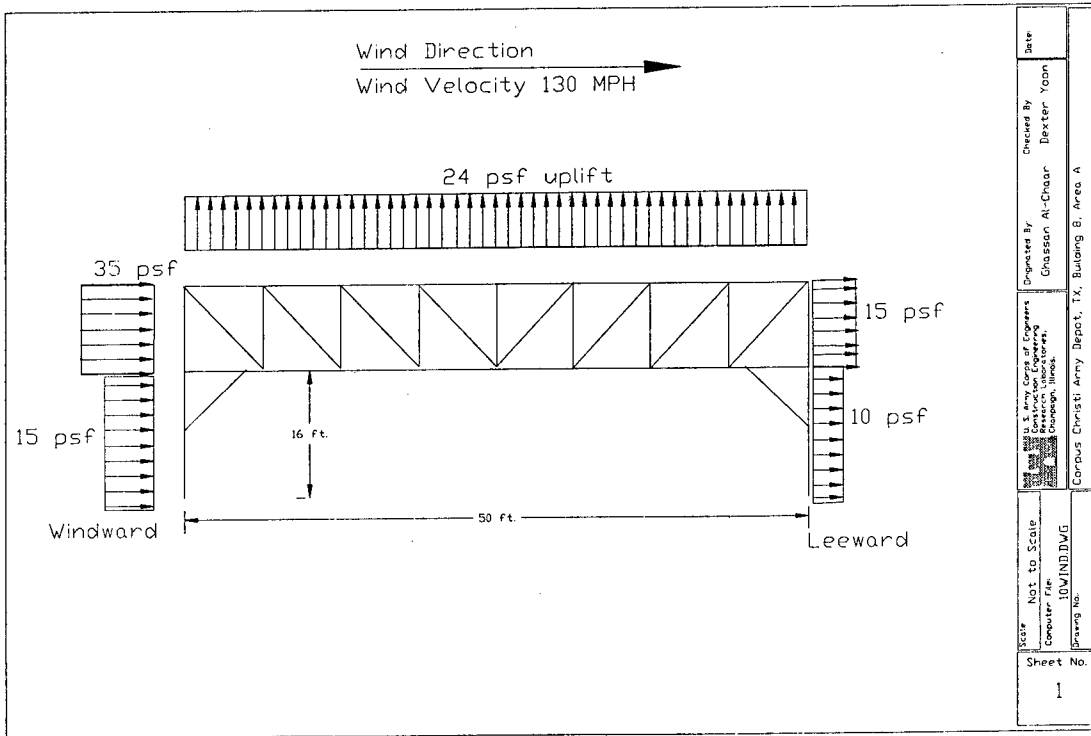

Figure 10. Wind pressure distribution on Areas B, C, and D.

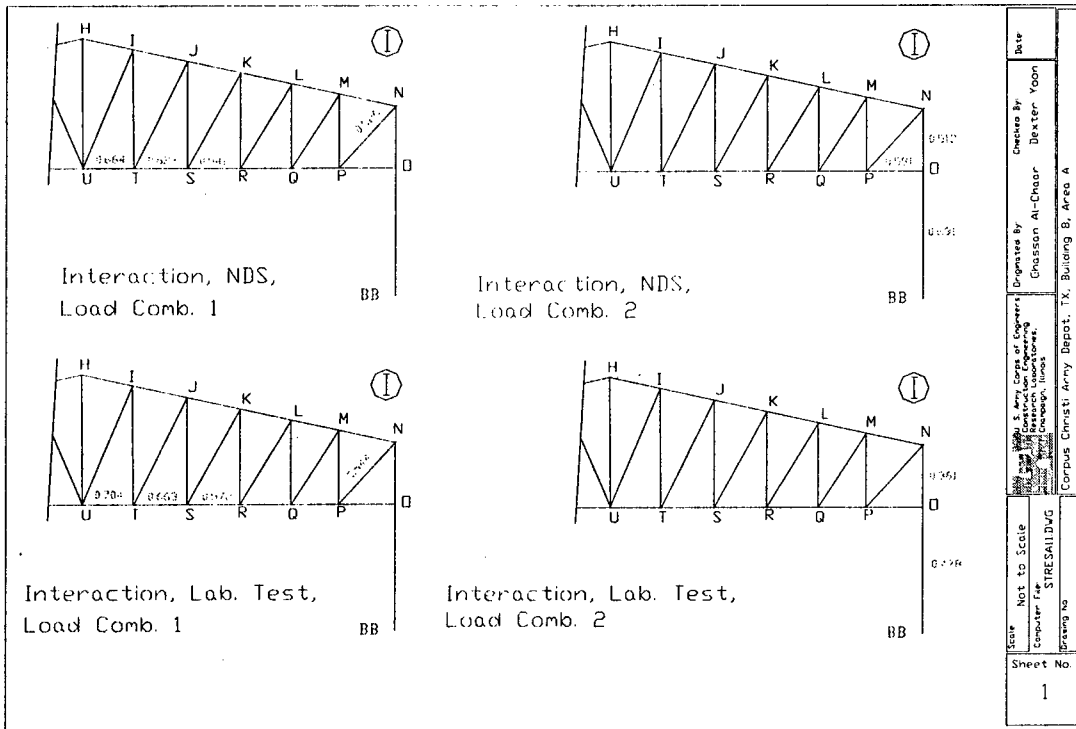

Figure 11. Maximum stress interaction in a typical truss in Area A.

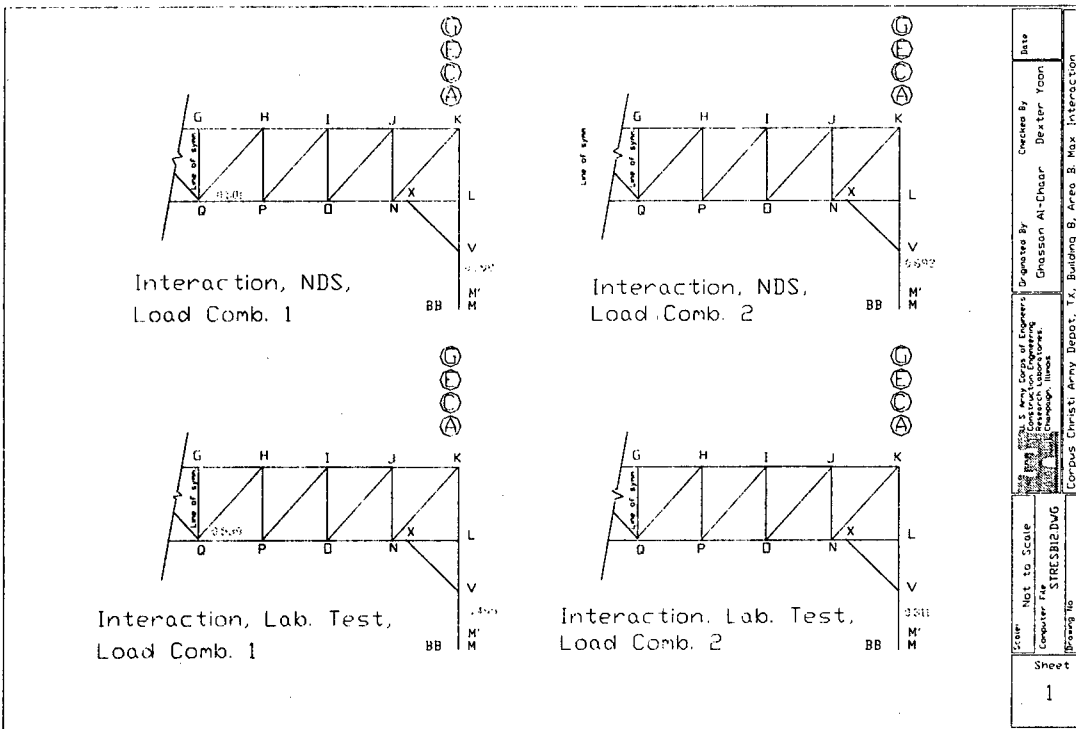

Figure 12. Maximum stress interaction in a typical truss in Area B.

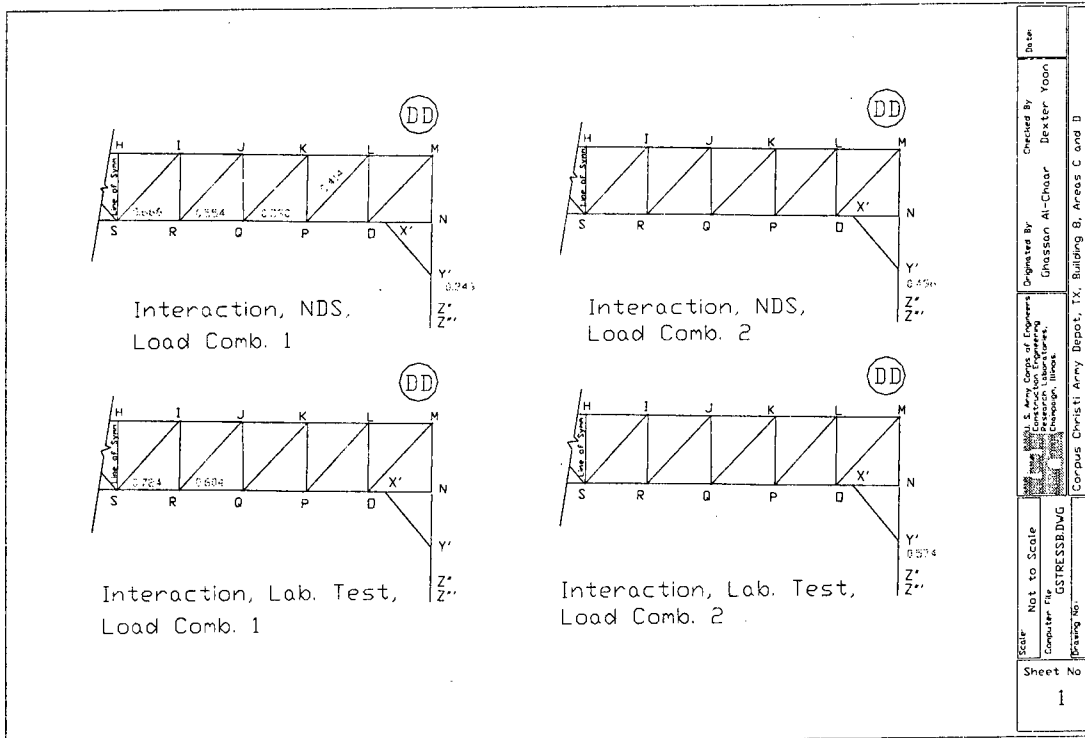

Figure 13. Maximum stress interaction in a typical truss in Areas C and D.

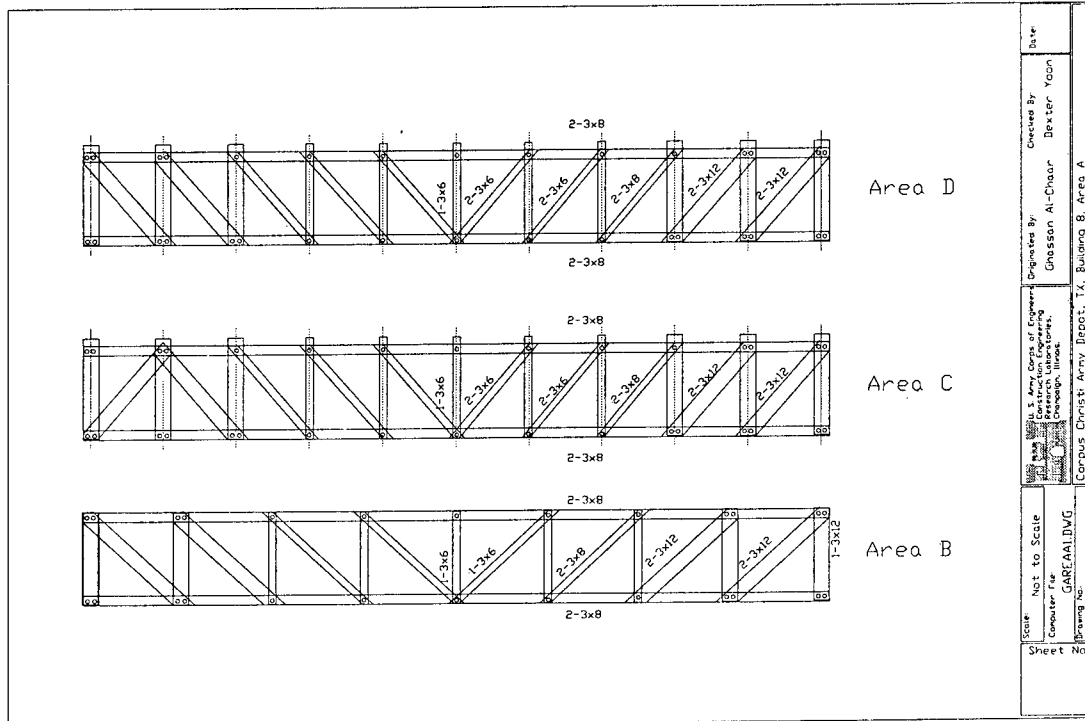

Figure 14. Typical trusses in Areas B, C, and D.

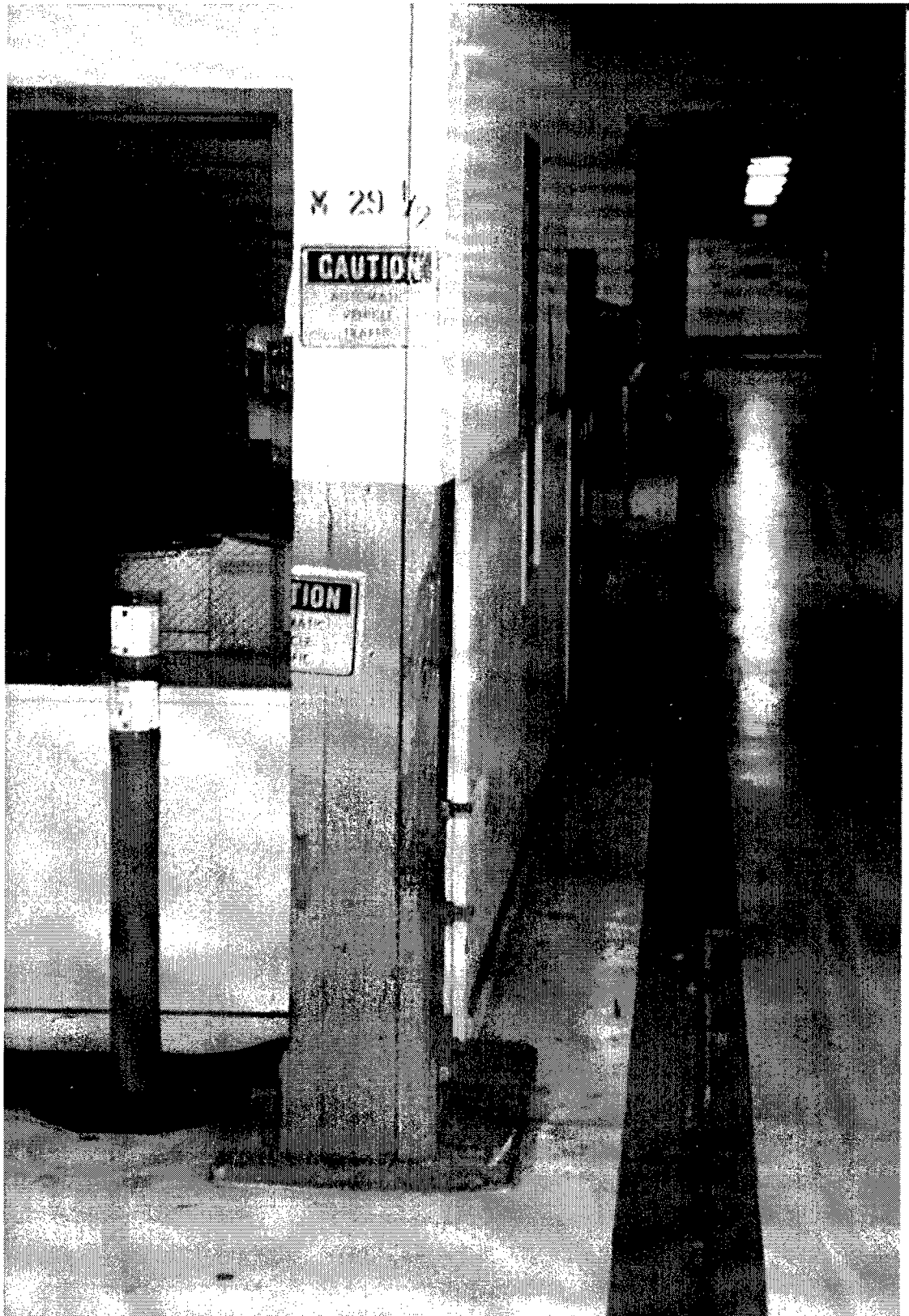

Photo 1. Column 29.5, Line M, damage by passing objects.



Photo 2. Misaligned slender column with loose bolts.



Photo 3. Typical type of existing repair in Area A.

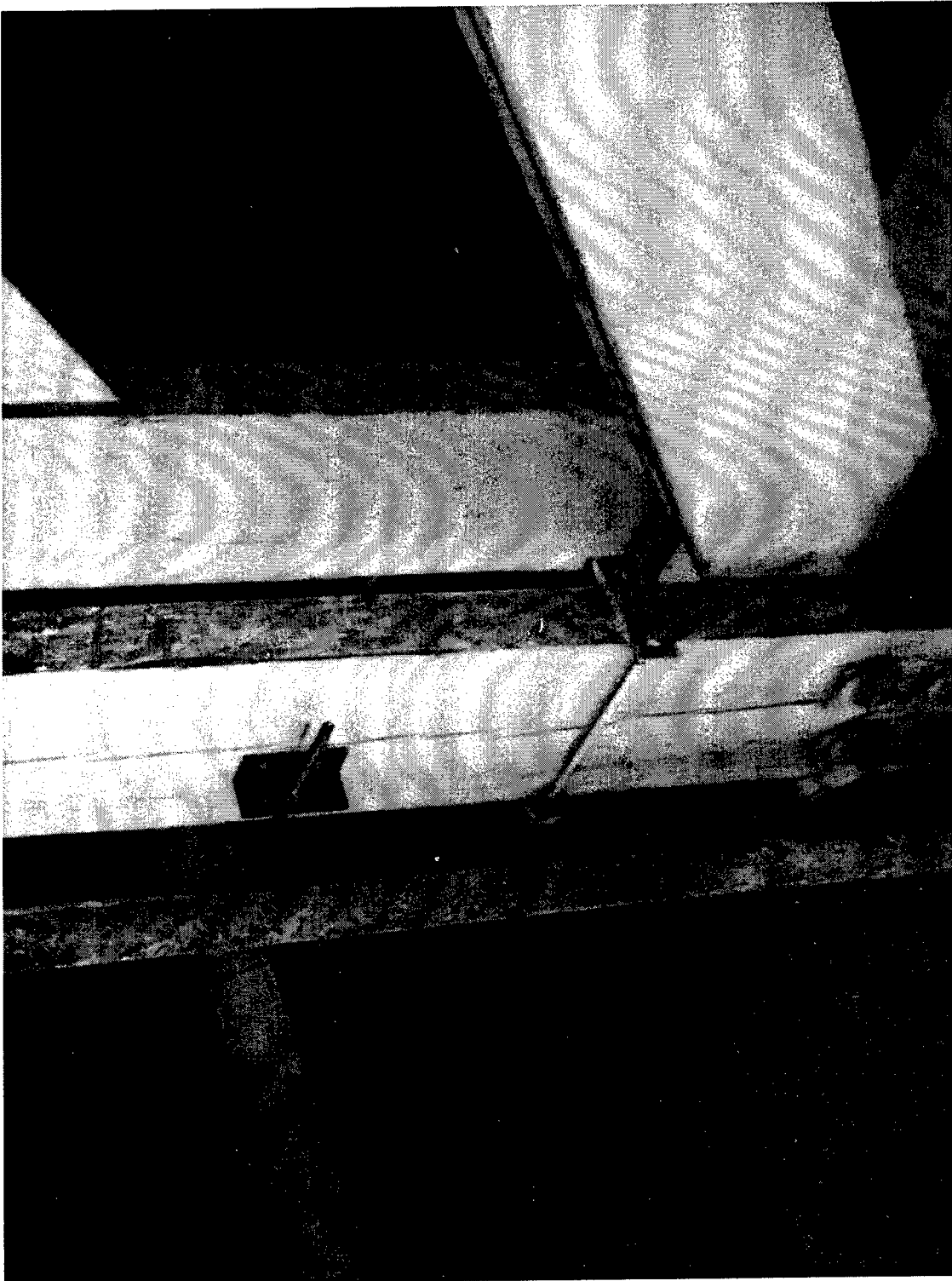

Photo 4. Typical existing repair in Area A.

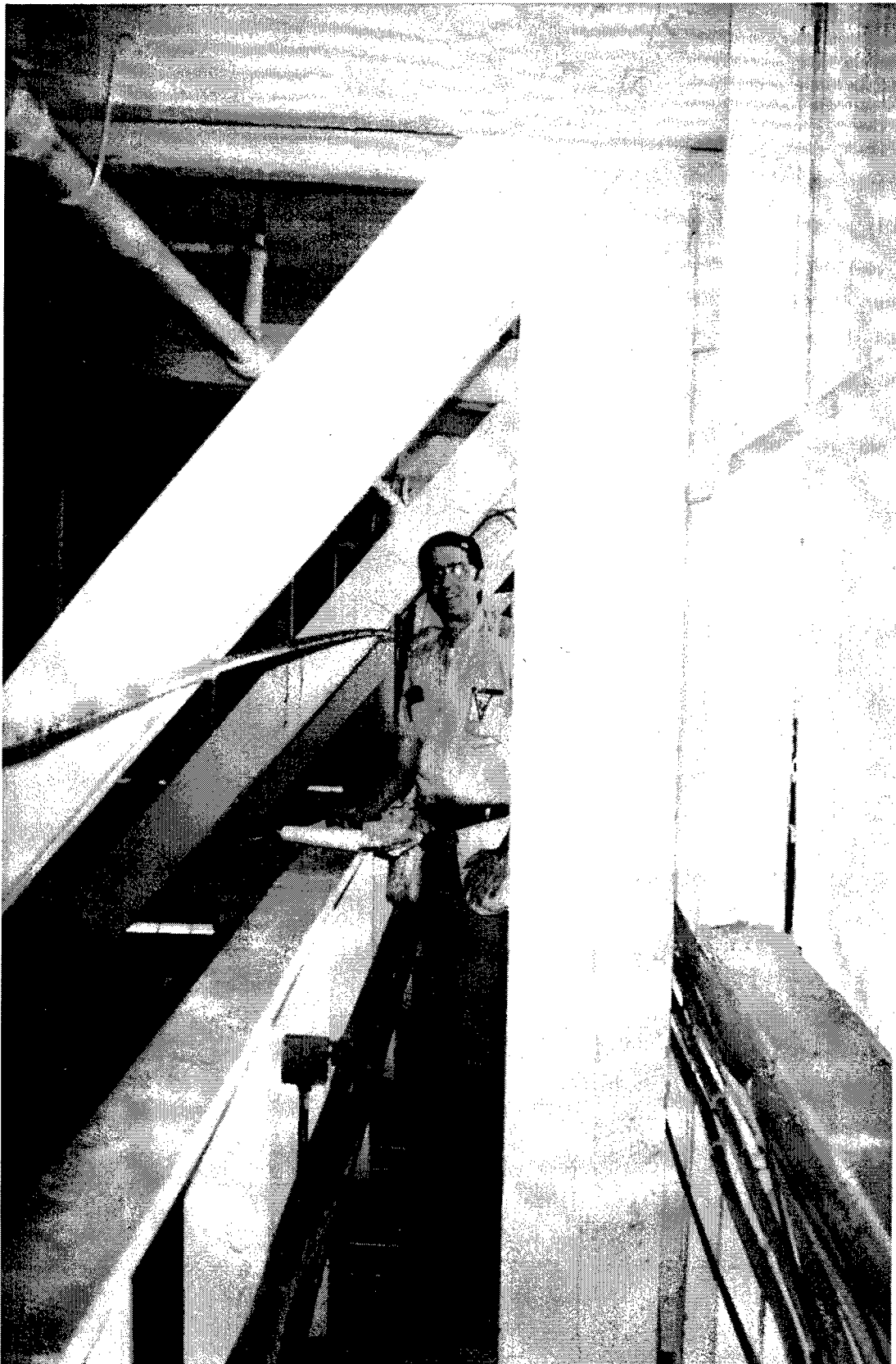

Photo 5. Typical large split in a column in Area A.

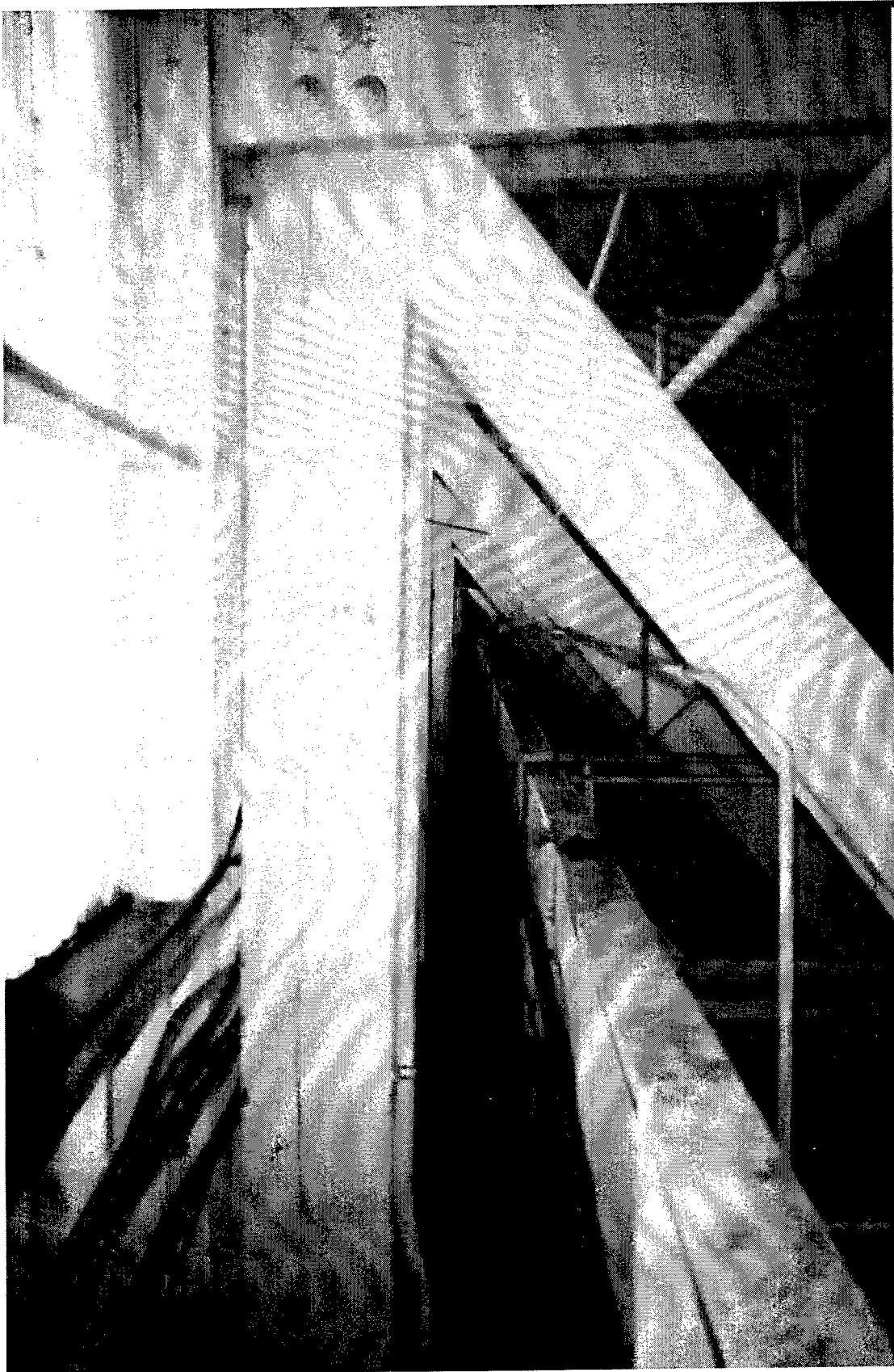

Photo 6. Typical small split in a column in Area A.

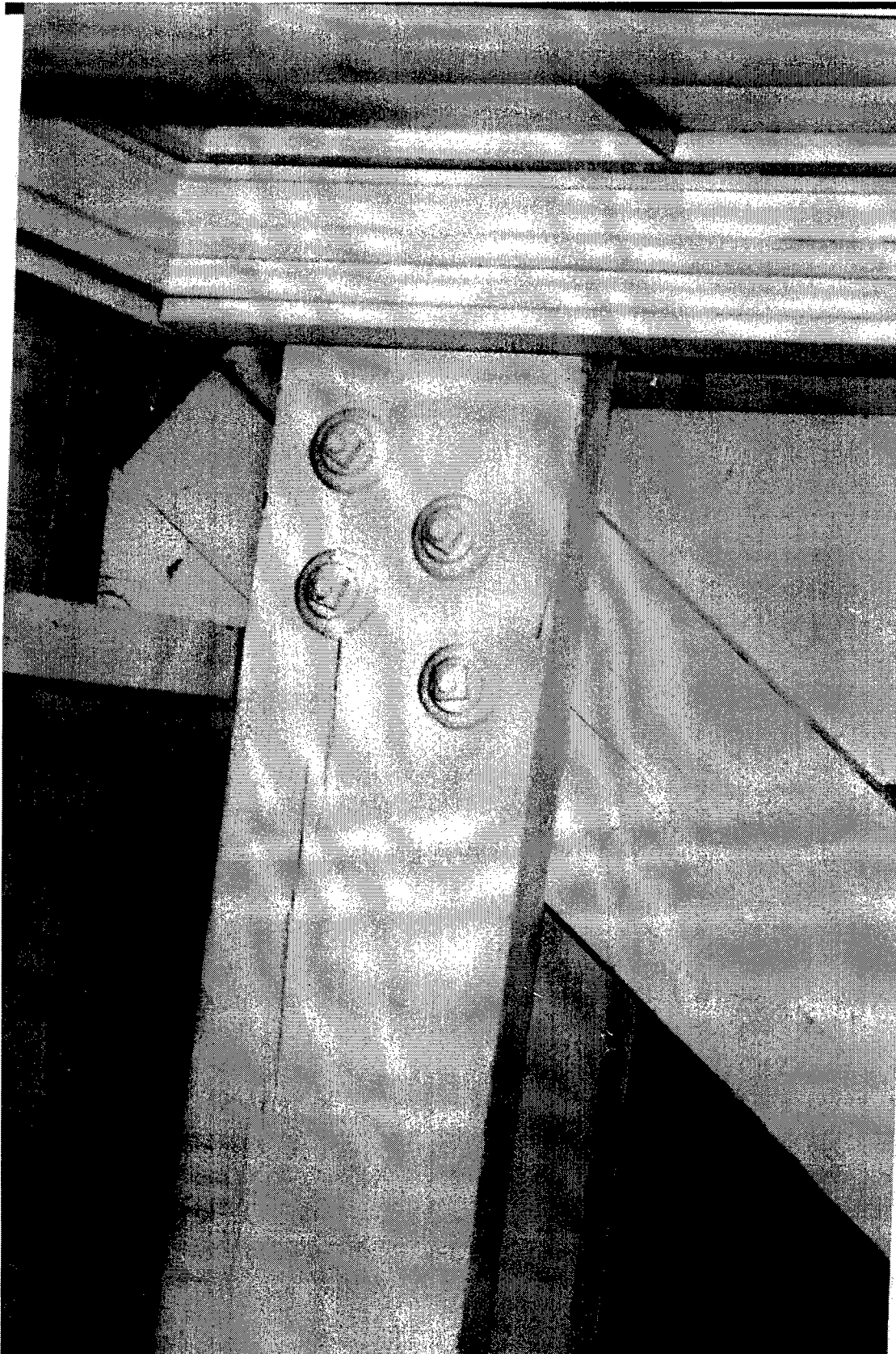

Photo 7. End split in a diagonal member in Building A.

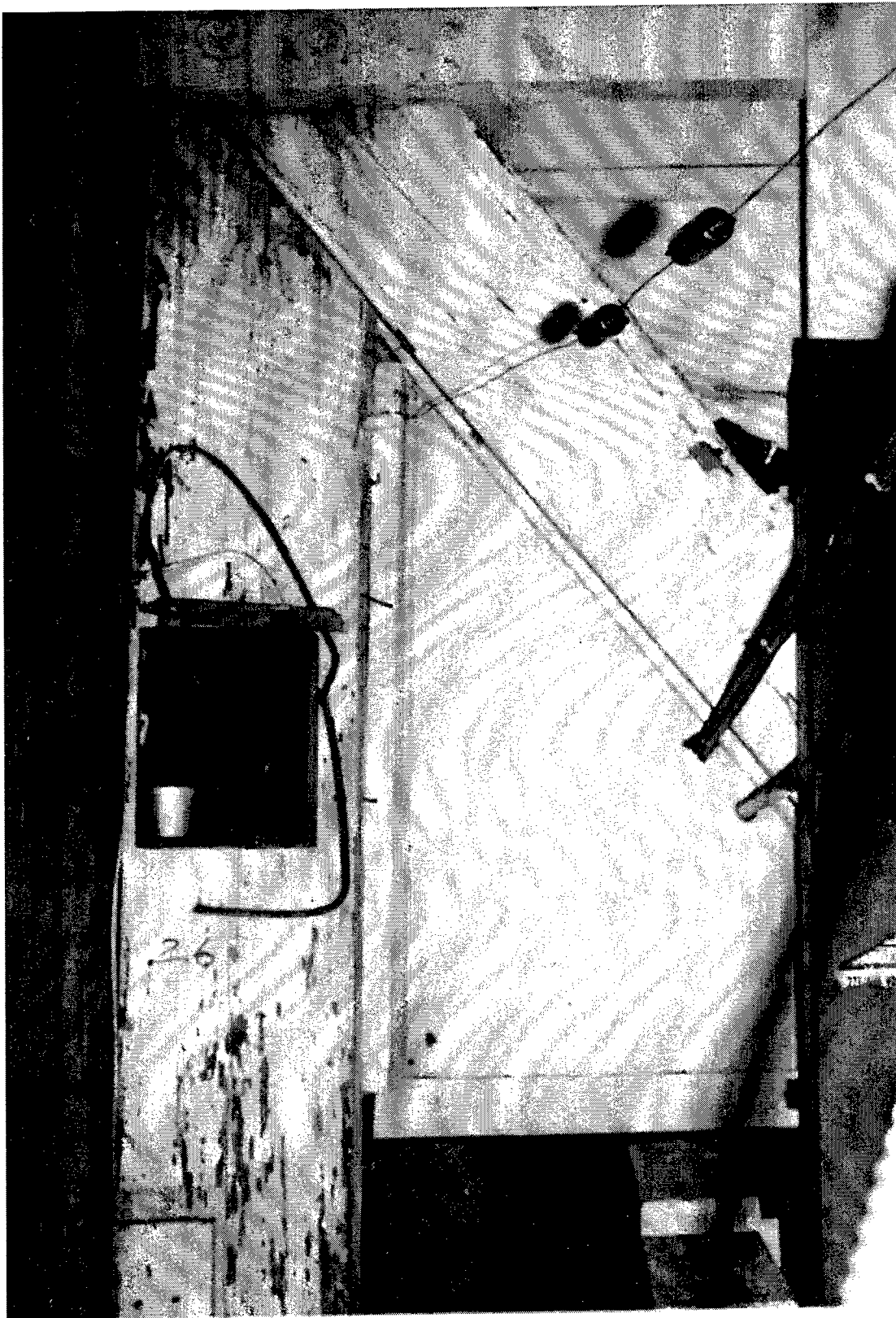

Photo 8. Decay due to leakage in Area A.



Photo 9. Major damage due to decay in a joint in Area A.

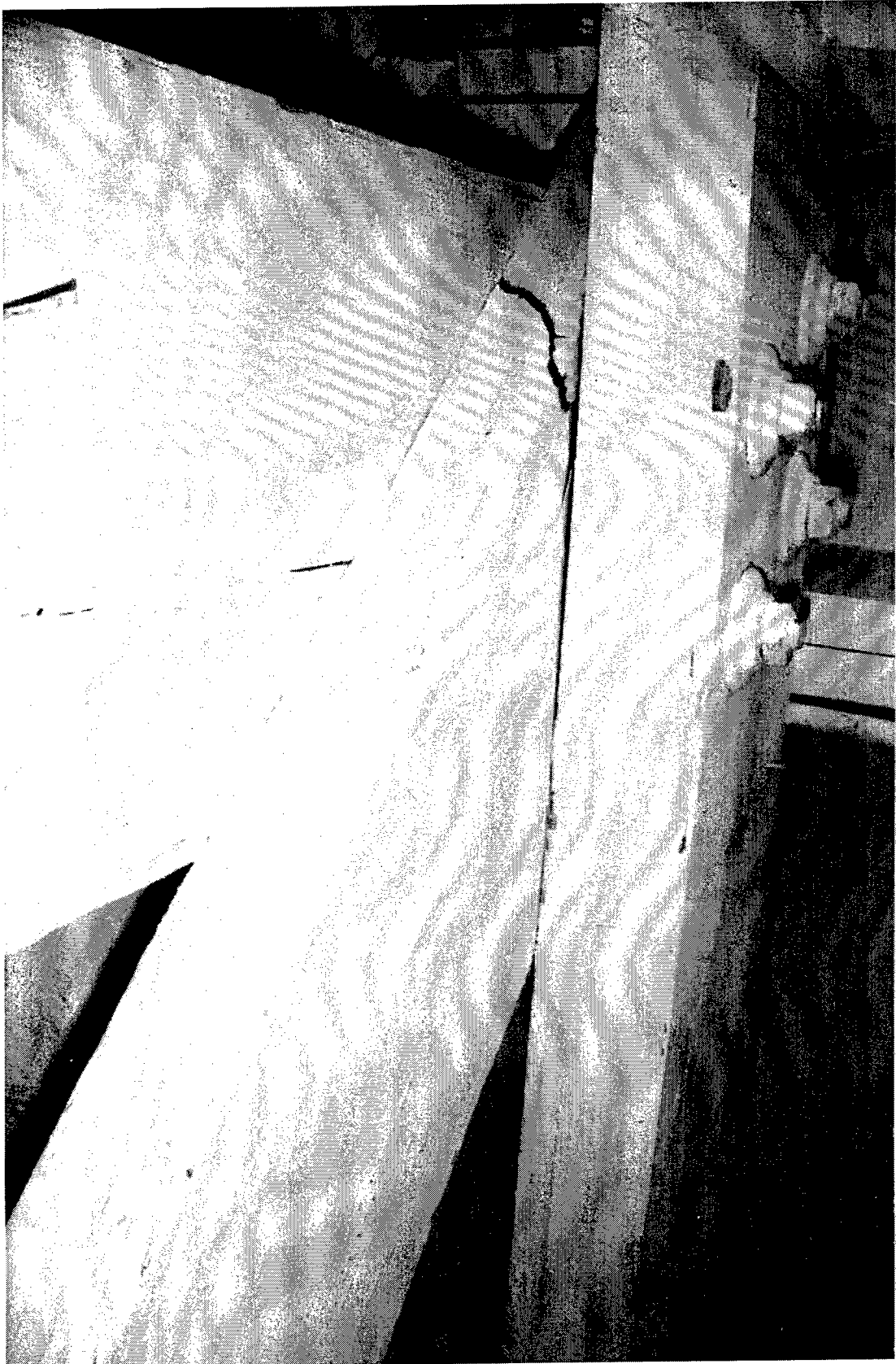

Photo 10. Fracture in diagonal member BZ of Truss 34, Building A.

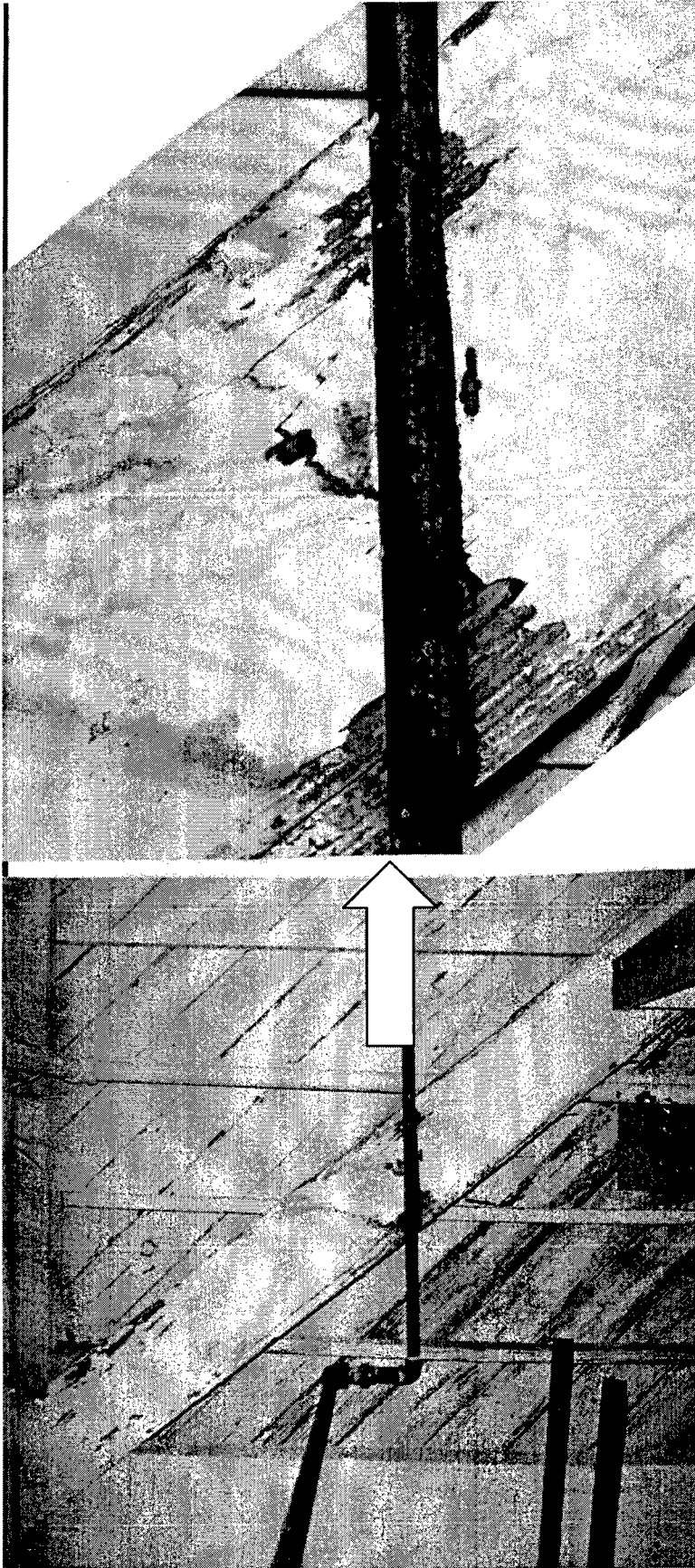

Photo 11. Tension failure in diagonal member PN of Truss 38, Area A.

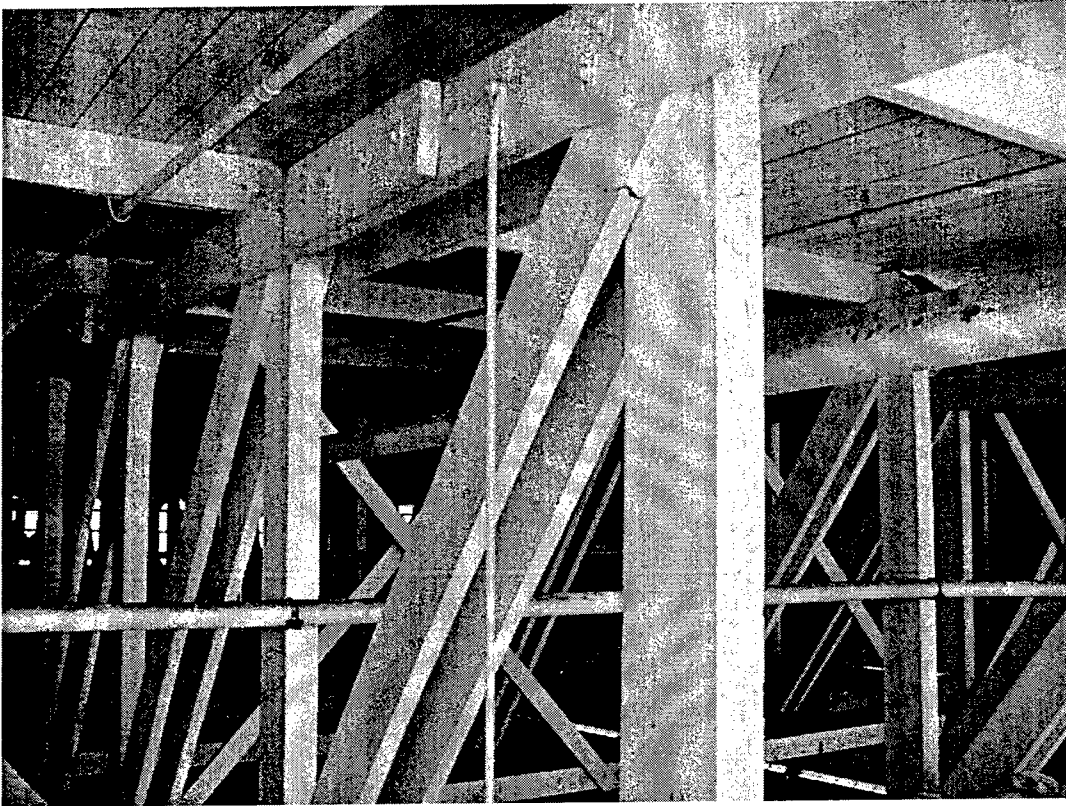

Photo 12. Fractured diagonal member CY of Truss 29.5, Area A.

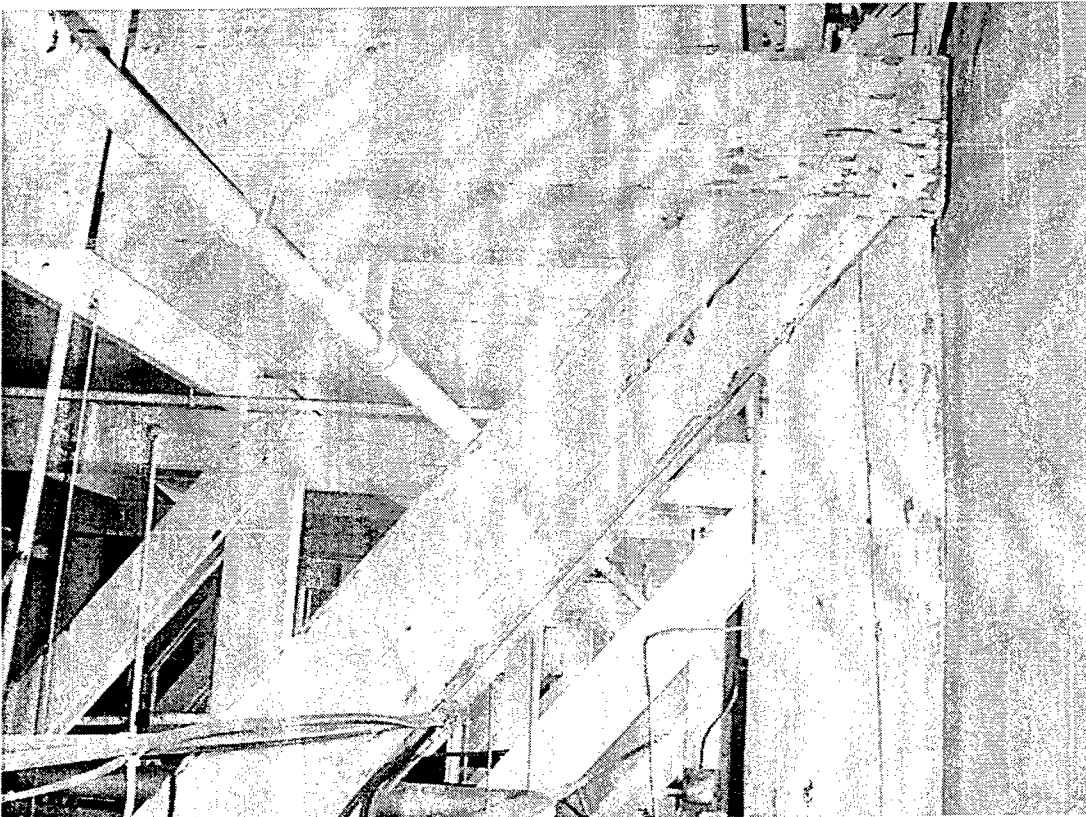

Photo 13. Fractured diagonal member BZ of Truss 27, Area A.

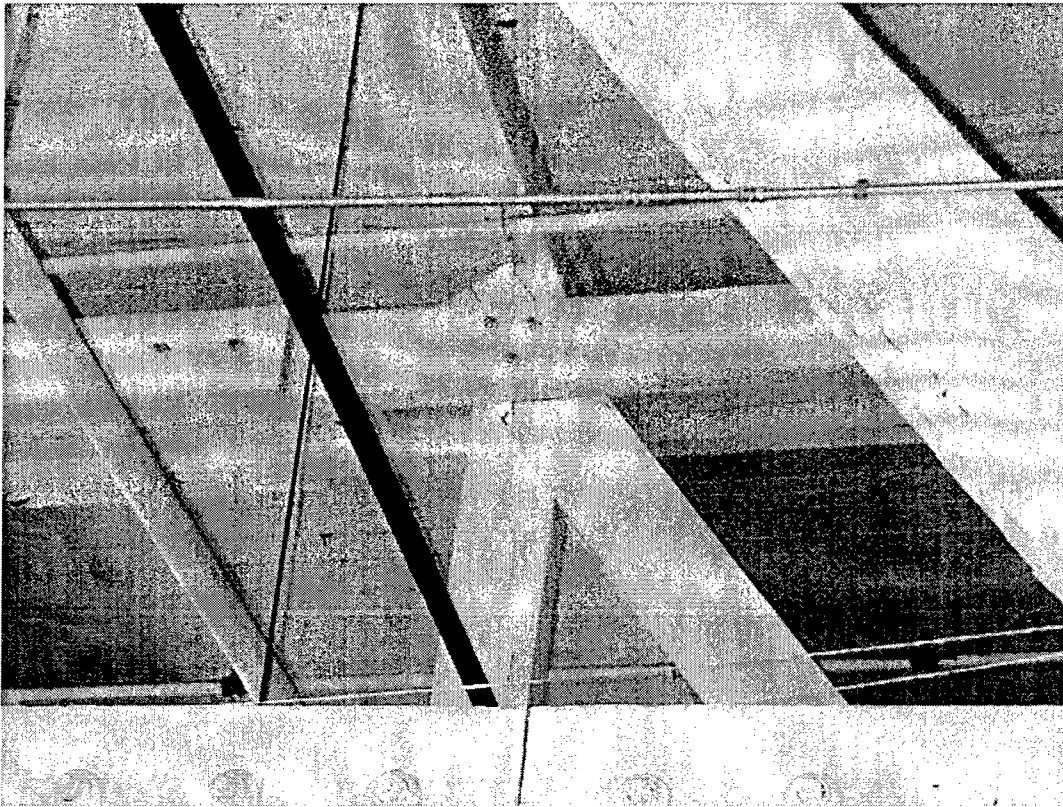

Photo 14. Fractured member QM of Truss 27, Area A.

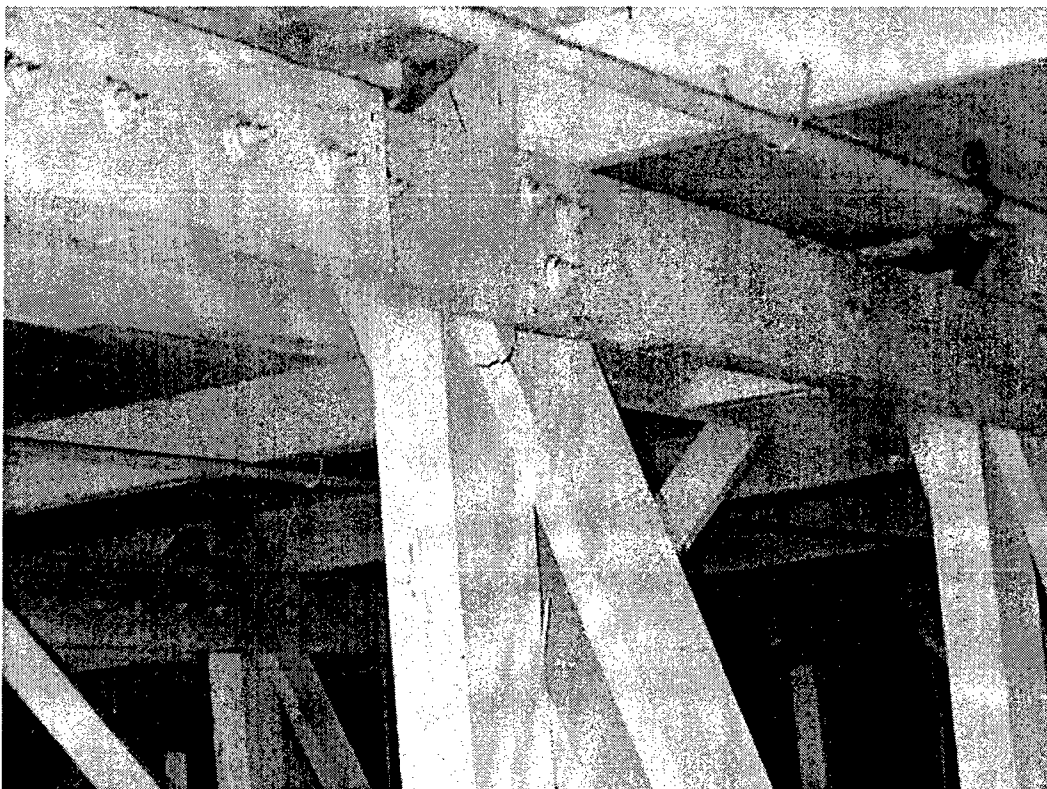

Photo 15. Fractured CY diagonal member in Truss 34, Area A.

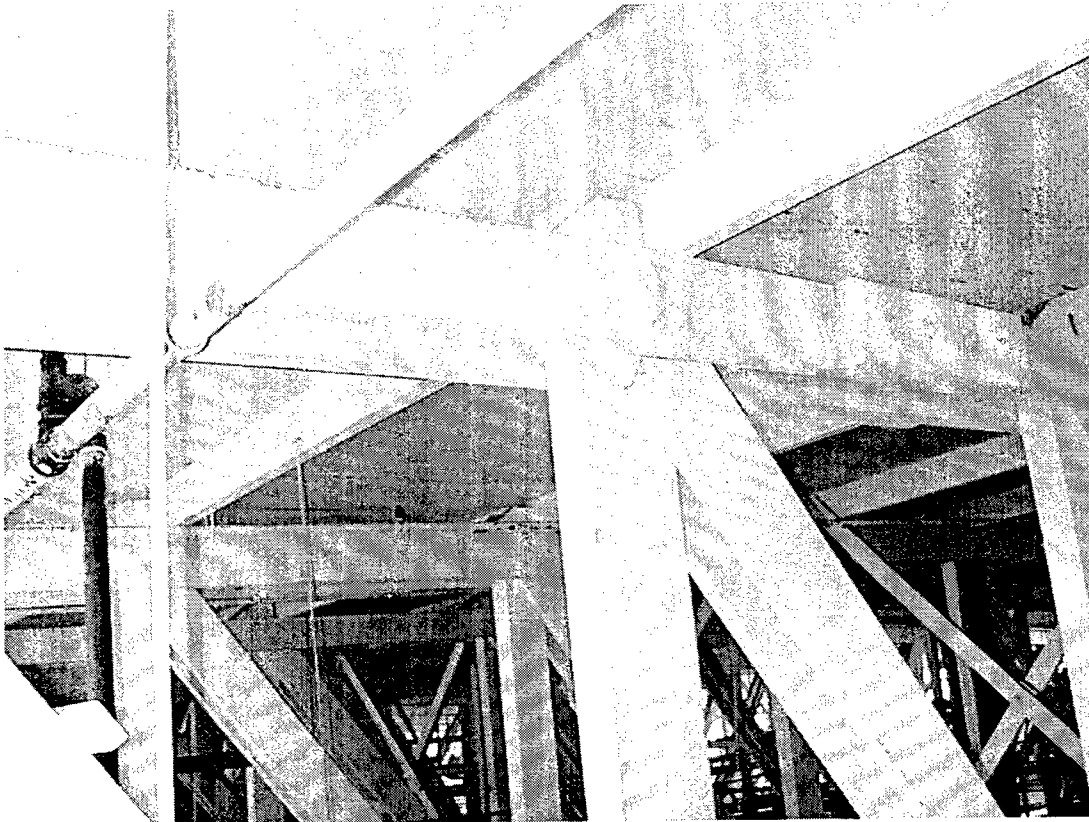

Photo 16. Fractured diagonal member DX of Truss 36, Area A.

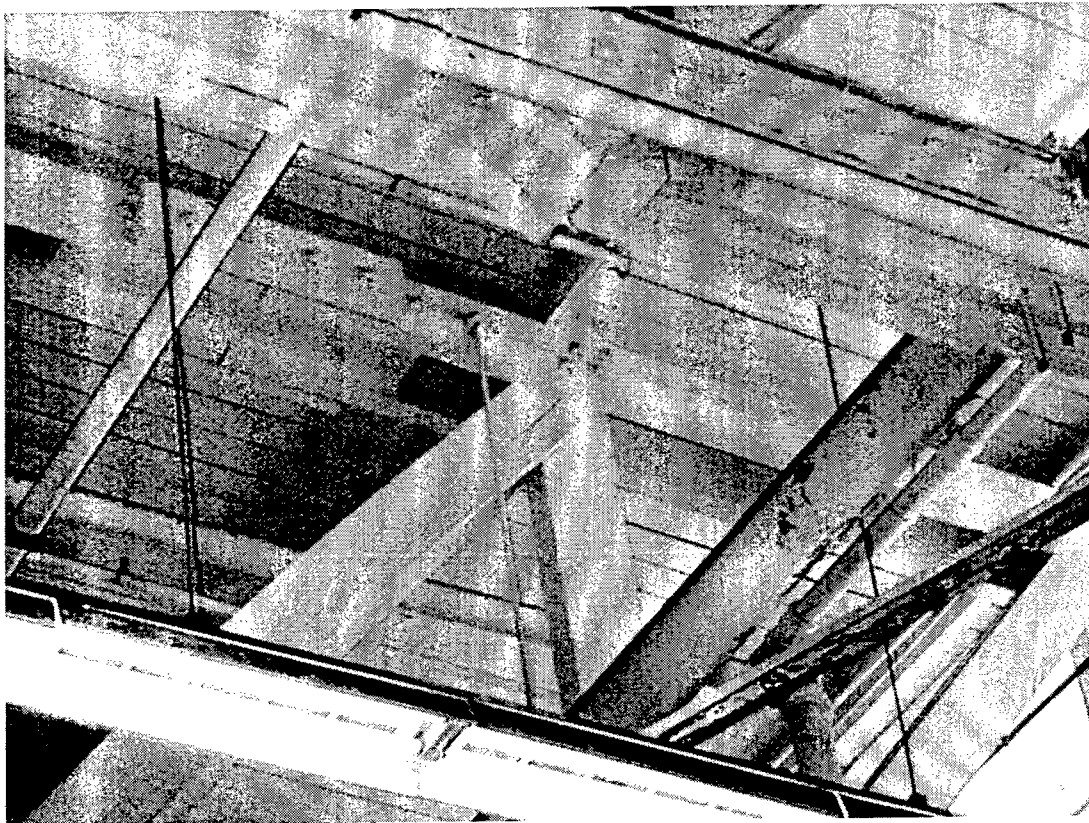

Photo 17. Fractured diagonal member QM of Truss 36.5, Area A.



Photo 18. Cantilever pipe support on diagonal members of Truss 34, Area A.



Photo 19. Water collected on the roof surface of Area B.

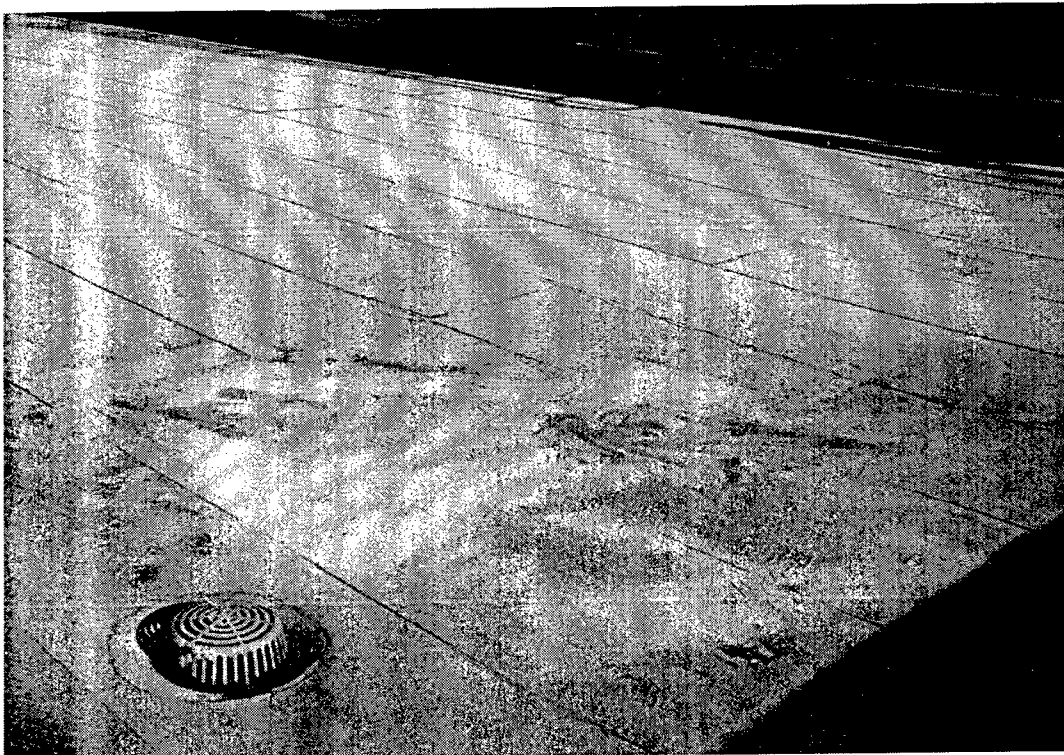

Photo 20. Pond and sag in the roof of Area D.

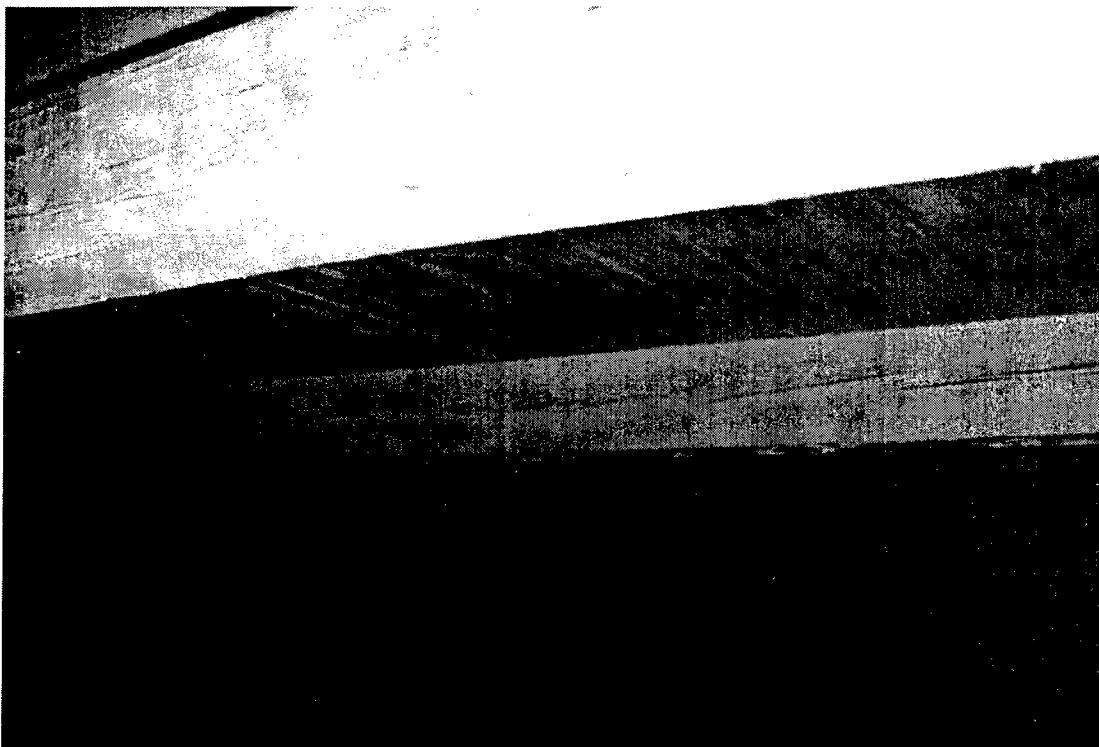

Photo 21. Over stressed purlin.



Photo 22. Using the coring on termite damaged column.



Photo 23. Using the moisture content meter on termite damaged column.

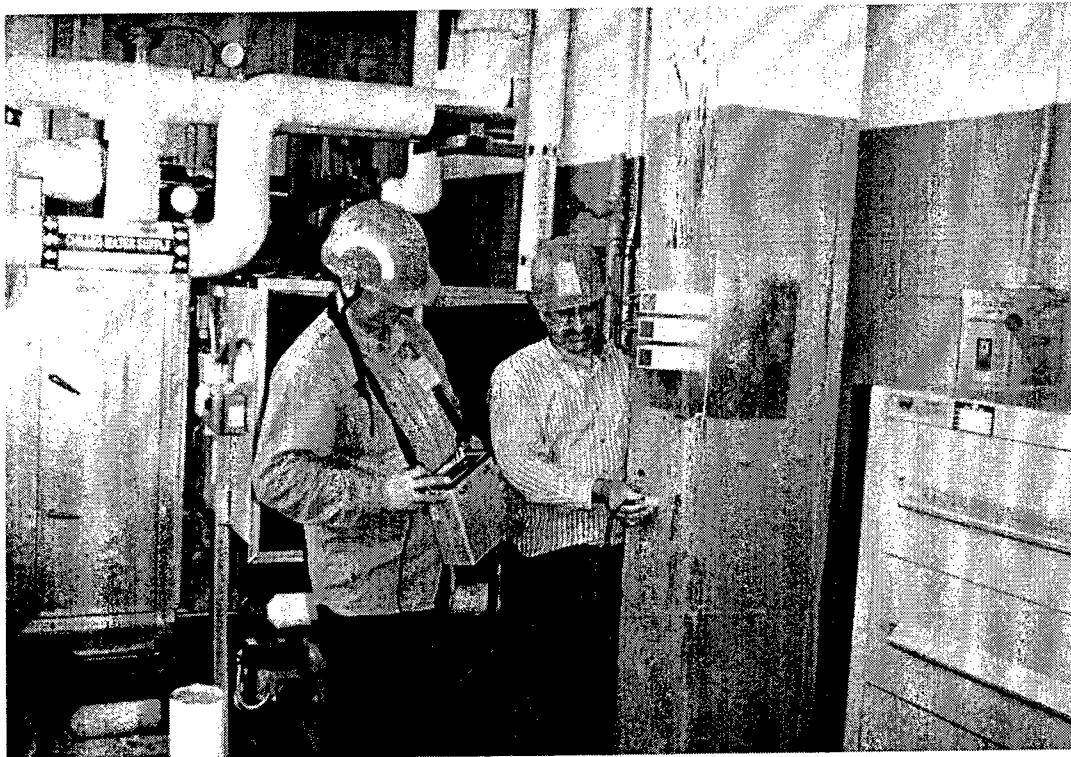

Photo 24. Using the V-Meter on termite damaged column.



Photo 25. Leakage from a sink that will damage a column.

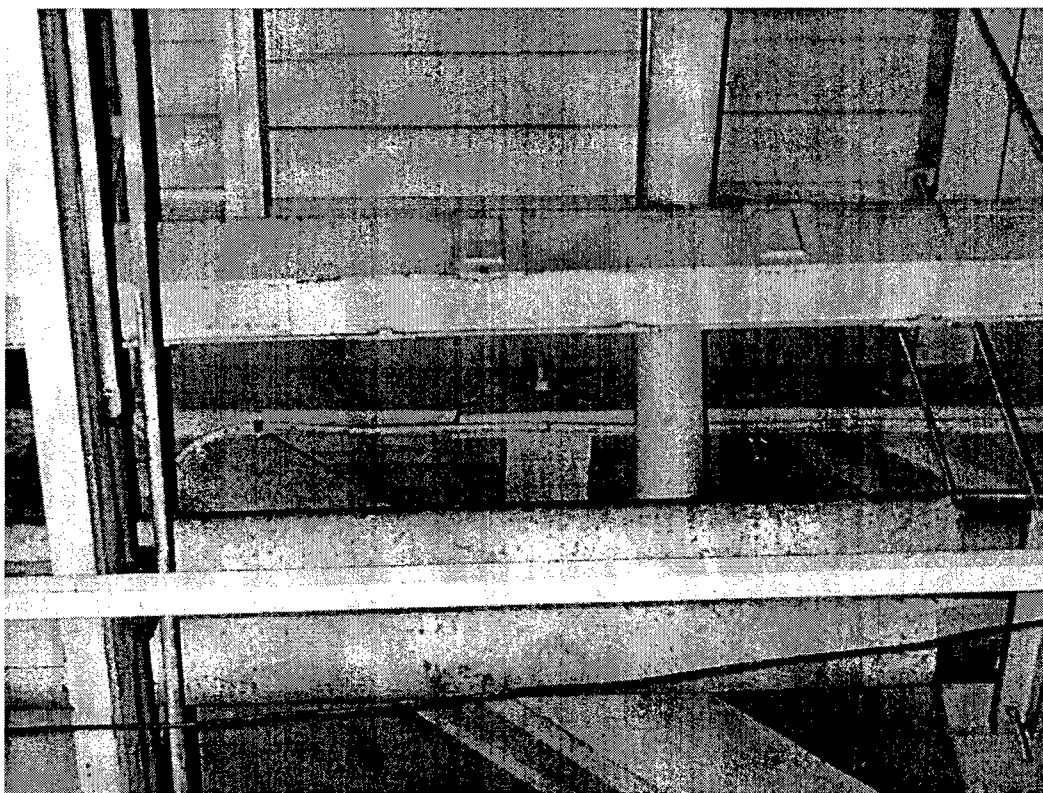

Photo 26. Fractured chord of Truss 40, Section IG, Area B.

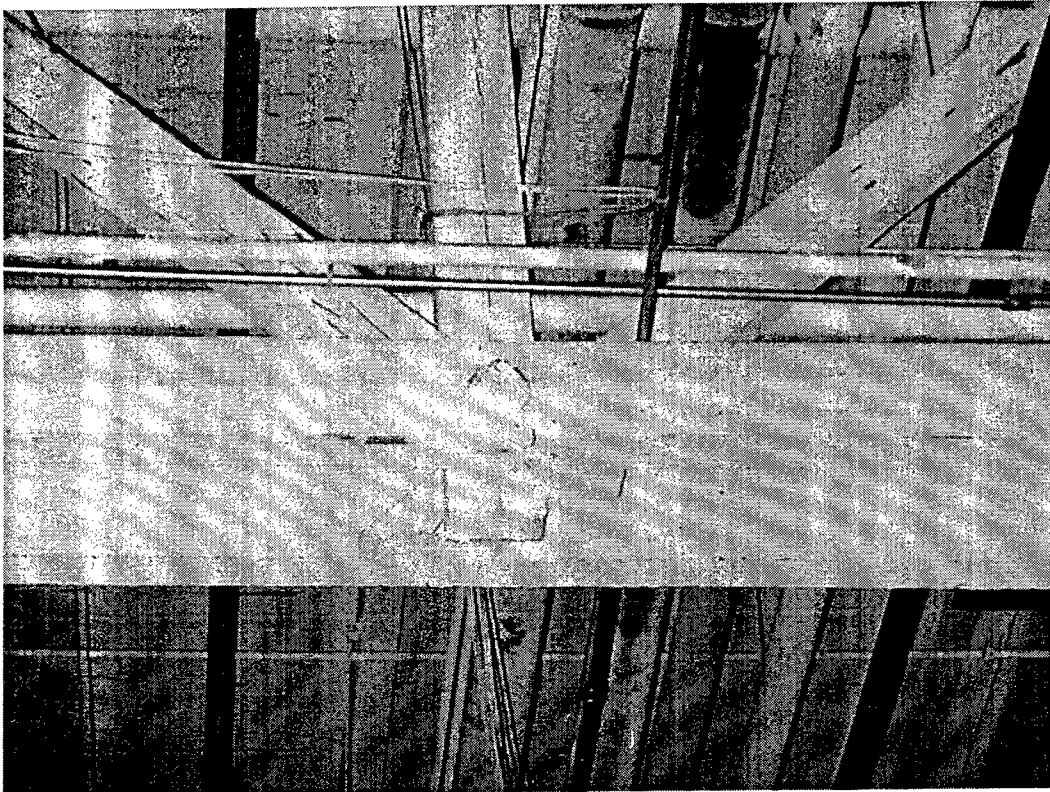

Photo 27. Fracture in chord RT line 56, Area D.



Photo 28. Fracture on member CT of column line 63.



Photo 29. Specimens cut and conditioned in a chamber at 68 percent humidity and 67 °F.



Photo 30. Static bending test.

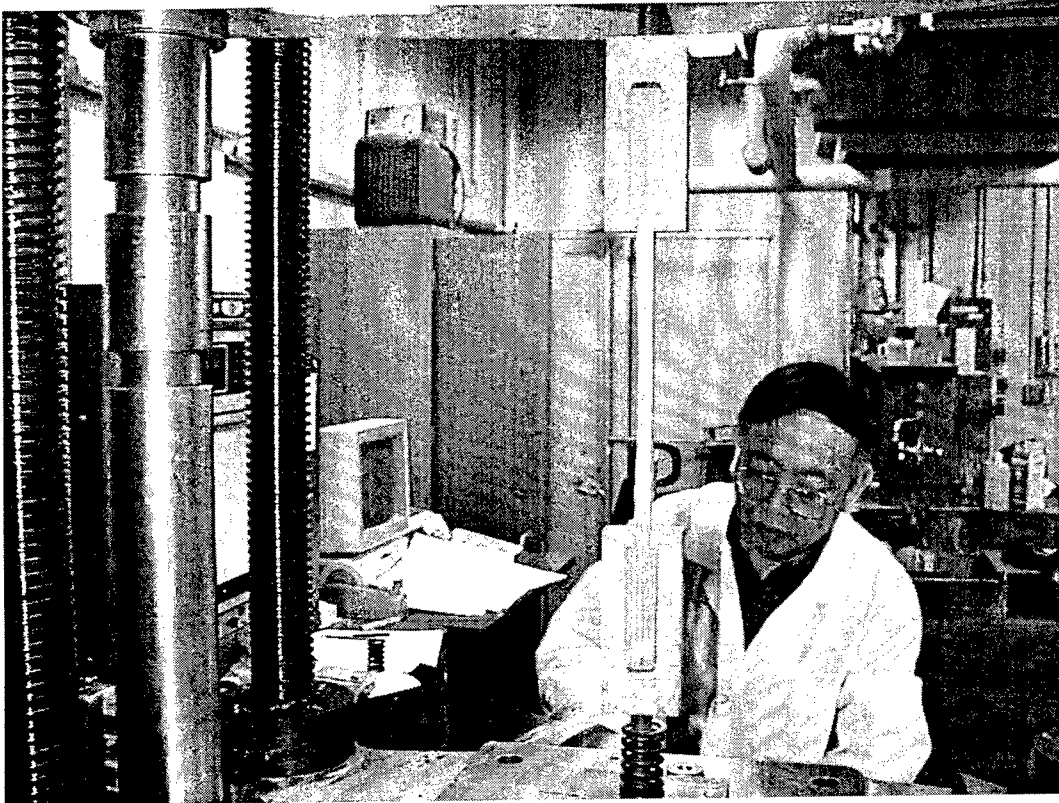

Photo 31. Tension parallel-to-grain test.

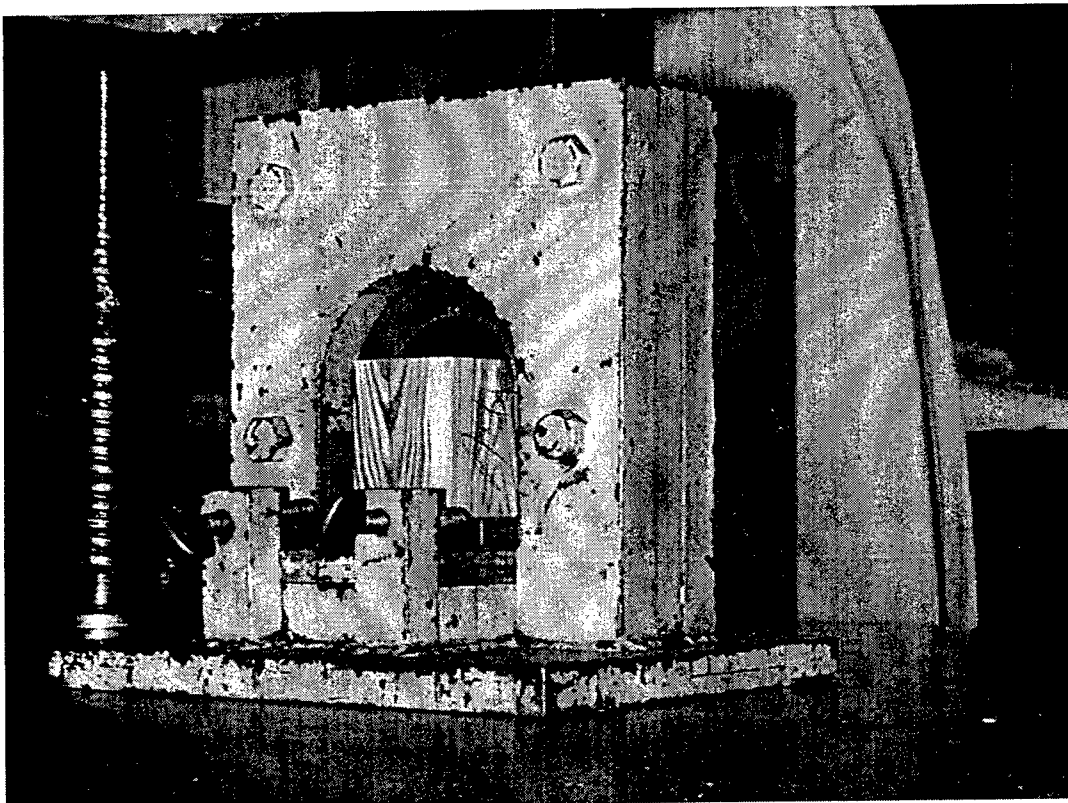

Photo 32. Shear parallel-to-grain test.

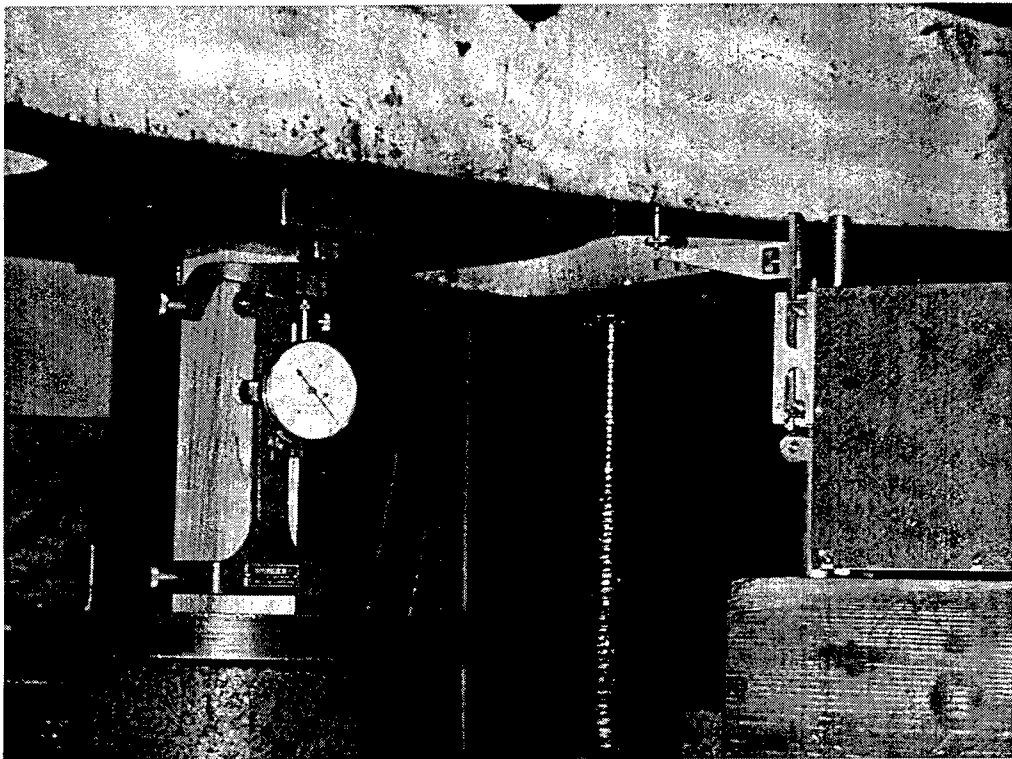

Photo 33. Typical failure for compression parallel-to-grain test.

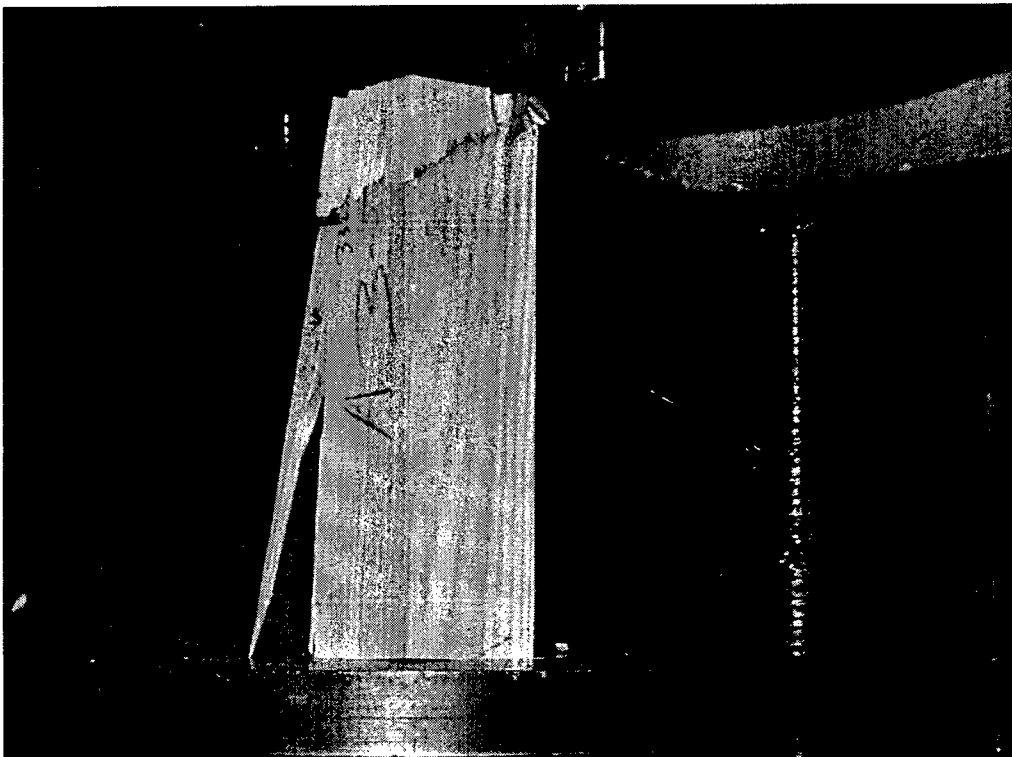

Photo 34. Compression parallel-to-grain test with deformation gauge.

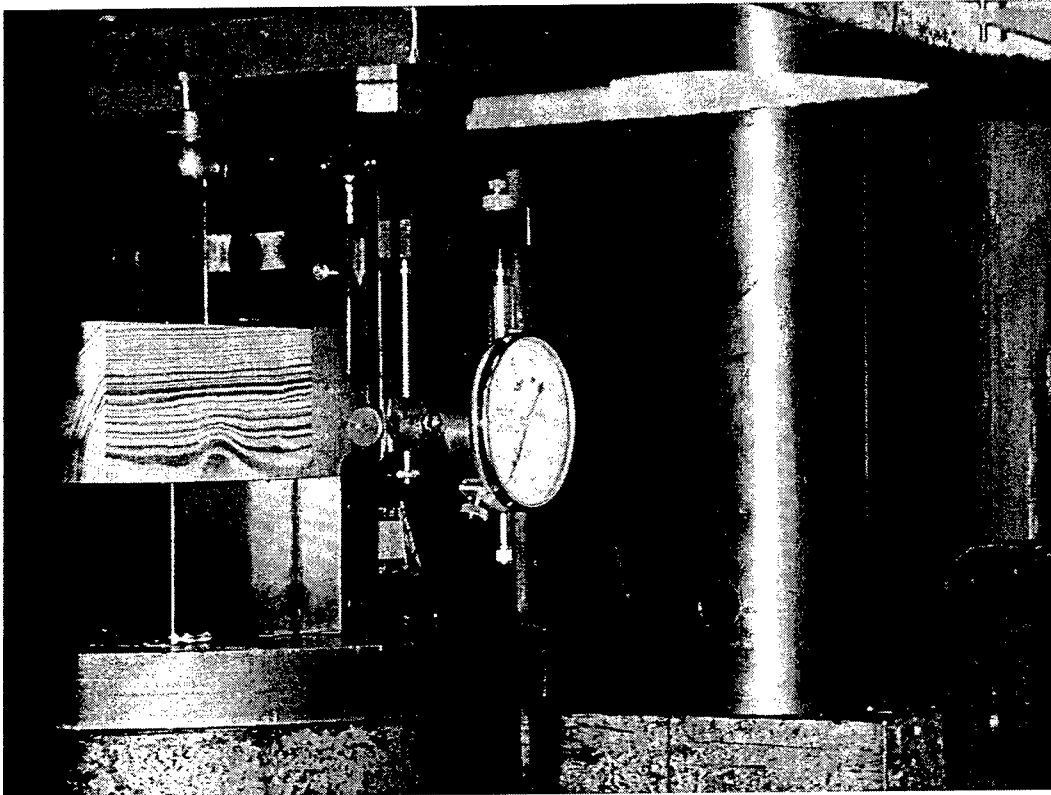

Photo 35. Compression perpendicular-to-grain test.

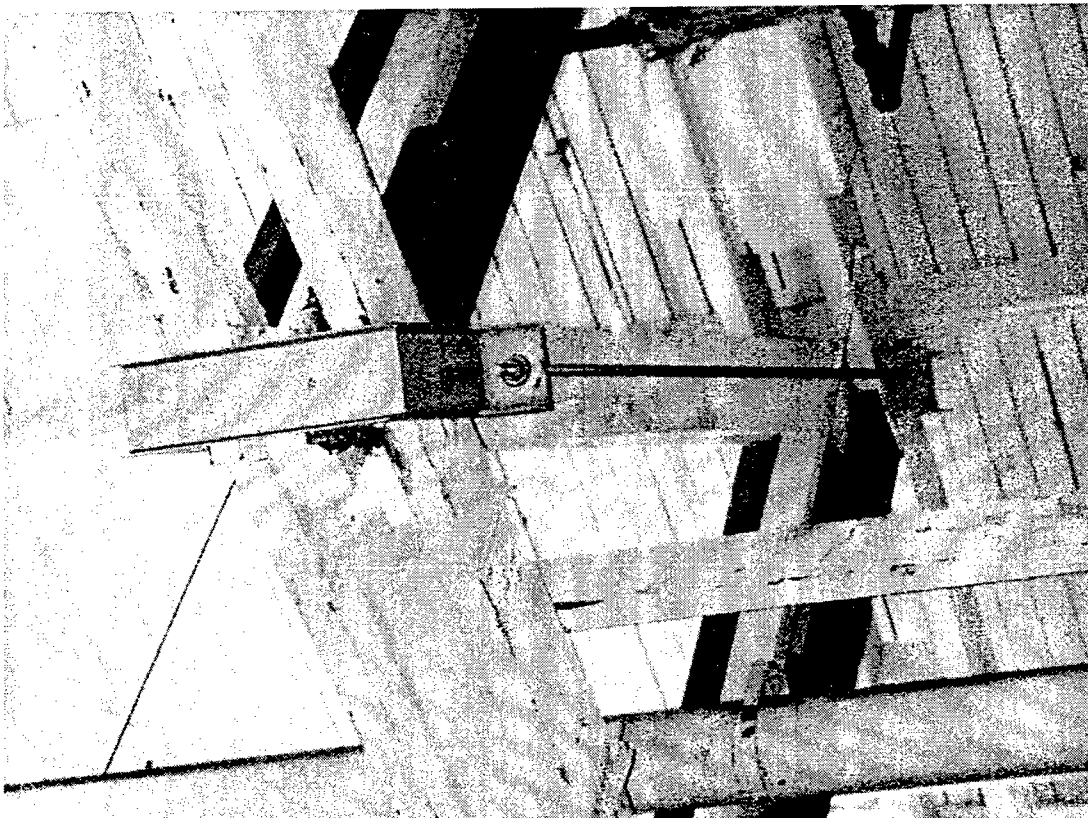

Photo 36. Endorsed repair for a fractured diagonal member.

References

- Al-Chaar, Ghassan. Letter report entitled "Wood Trusses and Purlins Inspection of Building 8, in Corpus Christi Army Depot, Texas", dated June 1996.
- American Forest and Paper Association (AF & PA). 1997. Supplement Natural Design Specification for Wood Construction. American Wood Council, AF & PA, Washington, DC.
- American Society for Testing and Materials (ASTM). 1996. Standard Grading Rules for Southern Pine Lumber, SPIB, Pensacola, FL.
- ANSI/ASCE 7-95, ASCE Standard "Minimum Design Loads for Building and Other Structures," May 12, 1994.
- Army Regulation 420-70, 29 May 1992, Facilities Engineering Buildings and Structures, paragraph 3.21 and Appendix C.
- ASTM. 1996. Standard Practice for Establishing Structural Grades and Related Allowable Properties for Visually Graded Lumber. Designated: D 245-93. vol 04.10 Wood, ASTM, West Conshohocken, PA.
- ASTM. 1996. Standard Test Methods for Establishing Clear Wood Strength Values. Designation: D 2555-95. vol 04.10 Wood, ASTM, West Conshohocken, PA.
- Issa, Mohsen and Al-Chaar, Ghassan "Structural Evaluation Procedure for Heavy Wood Truss Structures", USACERL Technical Report 98/89, June 1998.
- Southern Pine Inspection Bureau (SPIB). 1991. Standard Grading Rules for Southern Pine Lumber. SPIB, Pensacola, FL.
- USDA. Forest Service. 1987. Wood Handbook. Agricultural Handbook No. 72. USDA, Washington, DC.

Glossary

Allowable Property. The value of a natural property accepted as a standard for a specific design use. Allowable properties are identified with grade descriptions and standards that reflect the orthotropic structure of wood and anticipated end uses.

Blue Stain. A grayish discoloration of the sapwood caused by the growth of dark-colored fungi in the interior of the wood; made possible by the same conditions that favor the growth of other fungi.

Decay. The decomposition of wood substance by fungi.

Dense SYP. Either end of each piece of dense southern yellow pine (SYP) shall have an average of not less than six annual rings per inch, and one-third or more summer wood (the darker, harder portion of the annual ring) measured on a representative radial line. Pieces that average not less than four annual rings per inch shall be accepted as dense if they average one-half or more summer wood.

Density. The mass of wood substance enclosed within the boundary surfaces of a wood-plus-voids complex having a unit volume.

Pith. The soft core occurring near the center of a tree trunk, log, branch, or twig.

Radial Section. A length-wise section in a plane that passes through the centerline of a tree trunk.

Specific Gravity. As applied to wood, the ratio of the oven-dry weight of a sample to the weight of a volume of water equal to the volume of the sample at a specific moisture content (green, air-dry, or oven-dry). One cubic foot of water is equivalent to 62.4 lb.

Strength Ratio. The ratio of the strength of a structural member to that which it would have if it contained no strength-reducing characteristics (knots, slope of grain, shake, etc.).

Tangential. Coincident with a growth ring. A tangential section is a longitudinal section through a tree or limb perpendicular to radius. Flat-grained lumber is sawed tangentially.

Appendix A: Inspection Tables for Area A

Table A1: The Inspection of Area A, Column Line: 22 1/2

Member	T/C	H/V/D	Ls	Ss	R	Es*	Bsc	D	Remarks
AB	C	V	X			X@B		X	Decayed column due to leakage
BC	C	H	X			X@B			Leakage from ceiling
CD	C	H	X				X		Leakage from ceiling
DE	C	H	X						
EF	C	H					X		
FG	C	H	X						
GH	C	H	X						
HI	C	H				X@H			
IJ	C	H							
JK	C	H		X					
KL	C	H							
LM	C	H		X					
MN	C	H						X@N	
NO	C	V	X			X@N		X	Leakage from ceiling
OP	T	H		X					
PQ	T	H							
QR	T	H		X					
RS	T	H		X					
ST	T	H							
TU	T	H							
UV	T	H				X@U			
VW	T	H					X		
WX	T	H	X						
XY	T	H	X						
YZ	T	H	X						
ZA	T	H					X		
BZ	T	D	X			X@B			
ZC	C	V			X				
CY	T	D							
YD	C	V			X				
DX	T	D							
XE	C	V	X						
EW	T	D							
WF	C	V							
FV	T	D							
VG	C	V	X						
GU	T	D							
UH	C	V				X@H			
UI	T	D							
IT	C	V				X@I			
TJ	T	D							
JS	C	V							
SK	T	D		X					
KR	C	V							
RL	T	D							
LQ	C	V							
QM	T	D		X					
MP	C	V			X				
PN	T	D	X			X@N			

* Accessibility during repair may require removing an external wood siding for all highlighted members.

Table A2: The Inspection of Area A, Column Line: 23

Member	T/C	H/V/D	Ls	Ss	R	Es*	Bsc	D	Remarks
AB	C	V	X		X	X@B		X	Leakage from ceiling
BC	C	H		X		X@C			Leakage from ceiling
CD	C	H		X			X		
DE	C	H							
EF	C	H							
FG	C	H							
GH	C	H							
HI	C	H							
IJ	C	H							
JK	C	H		X			X		
KL	C	H							
LM	C	H							
MN	C	H		X		X@N			
NO	C	V		X					
OP	T	H							
PQ	T	H							
QR	T	H							This member supports a HVAC
RS	T	H							This member supports a HVAC
ST	T	H							This member supports a HVAC
TU	T	H							
UV	T	H							
VW	T	H							
WX	T	H							
XY	T	H							
YZ	T	H					X		
ZA	T	H							
BZ	T	D	X			X@B			
ZC	C	V		X					
CY	T	D		X		X@C			
YD	C	V		X					
DX	T	D							
XE	C	V		X					
EW	T	D							
WF	C	V							
FV	T	D							
VG	C	V							
GU	T	D	X						
UH	C	V	X						
UI	T	D							
IT	C	V							
TJ	T	D							
JS	C	V							
SK	T	D							
KR	C	V			X				
RL	T	D							
LQ	C	V							
QM	T	D		X					
MP	C	V			X				
PN	T	D	X			X@N			

* Accessibility during repair may require removing an external wood siding for all highlighted members.

Table A3: The Inspection of Area A, Column Line: 23 1/2

Member	T/C	H/V/D	Ls	Ss	R	Es*	Bsc	D	Remarks
AB	C	V	X		X	X@B			Leakage from ceiling
BC	C	H							Leakage from ceiling
CD	C	H							
DE	C	H		X					
EF	C	H							
FG	C	H							
GH	C	H							
HI	C	H				X@H			
IJ	C	H							
JK	C	H							
KL	C	H	X						
LM	C	H							
MN	C	H							
NO	C	V	X			X@N			
OP	T	H							
PQ	T	H		X					
QR	T	H							
RS	T	H							
ST	T	H		X					
TU	T	H							
UV	T	H							
VW	T	H							
WX	T	H							
XY	T	H							
YZ	T	H							
ZA	T	H							
BZ	T	D	X			X@B		X	Decay due to leakage
ZC	C	V							
CY	T	D	X						
YD	C	V		X					
DX	T	D		X					
XE	C	V							
EW	T	D							
WF	C	V							
FV	T	D							
VG	C	V		X					
GU	T	D							
UH	C	V		X					
UI	T	D							
IT	C	V							
TJ	T	D							
JS	C	V							
SK	T	D							
KR	C	V							
RL	T	D							
LQ	C	V							
QM	T	D							
MP	C	V	X		X			X	Significant decay
PN	T	D							

* Accessibility during repair may require removing an external wood siding for all highlighted members.

Table A4: The Inspection of Area A, Column Line: 24

Member	T/C	H/V/D	Ls	Ss	R	Es*	Bsc	D	Remarks
AB	C	V	X			X@B		X	Leakage from ceiling
BC	C	H				X@C			Leakage from ceiling
CD	C	H							
DE	C	H				X@D			
EF	C	H							
FG	C	H							
GH	C	H							
HI	C	H							
IJ	C	H							Supports ~6" pipe from col. 22 to 24 1/2
JK	C	H							
KL	C	H	X			X@K			
LM	C	H				X@L			
MN	C	H	X			X@M			
NO	C	V				X@N&O			Minor cracks on lower chord splices
OP	T	H							
PQ	T	H							
QR	T	H							
RS	T	H							
ST	T	H							
TU	T	H							
UV	T	H							
VW	T	H							
WX	T	H				X@X			
XY	T	H							
YZ	T	H							
ZA	T	H							
BZ	T	D							
ZC	C	V	X						
CY	T	D							
YD	C	V	X						
DX	T	D							
XE	C	V	X						
EW	T	D							
WF	C	V				X@F			
FV	T	D							
VG	C	V		X					
GU	T	D							
UH	C	V		X					
UI	T	D							
IT	C	V	X						
TJ	T	D							
JS	C	V							
SK	T	D				X@K			
KR	C	V							
RL	T	D				X@L			
LQ	C	V							
QM	T	D							
MP	C	V							
PN	T	D							

* Accessibility during repair may require removing an external wood siding for all highlighted members.

Table A5: The Inspection of Area A, Column Line: 24 1/2

Member	T/C	H/V/D	Ls	Ss	R	Es*	Bsc	D	Remarks
AB	C	V	X		X	X@B			Leakage from ceiling
BC	C	H							
CD	C	H							
DE	C	H							
EF	C	H							
FG	C	H							
GH	C	H		X					
HI	C	H							
IJ	C	H							
JK	C	H							
KL	C	H		X					
LM	C	H							
MN	C	H				X@N			
NO	C	V	X						
OP	T	H							
PQ	T	H							
QR	T	H		X					
RS	T	H							
ST	T	H							
TU	T	H							
UV	T	H		X					
VW	T	H							
WX	T	H							
XY	T	H							
YZ	T	H							
ZA	T	H							
BZ	T	D	X			X@B			Severe Leakage
ZC	C	V		X					
CY	T	D							
YD	C	V							
DX	T	D							
XE	C	V		X					
EW	T	D							
WF	C	V		X					
FV	T	D							
VG	C	V		X					
GU	T	D							
UH	C	V	X			X@H			
UI	T	D							
IT	C	V							
TJ	T	D							
JS	C	V		X					
SK	T	D							
KR	C	V			X				
RL	T	D							
LQ	C	V		X					
QM	T	D							
MP	C	V							
PN	T	D	X			X@N			

* Accessibility during repair may require removing an external wood siding for all highlighted members.

Table A6: The Inspection of Area A, Column Line: 25

Member	T/C	H/V/D	Ls	Ss	R	Es*	Bsc	D	Remarks
AB	C	V	X						
BC	C	H				X@C			
CD	C	H				X@D			
DE	C	H				X@E			
EF	C	H							
FG	C	H							
GH	C	H							
HI	C	H							
IJ	C	H							
JK	C	H					X		
KL	C	H							
LM	C	H							
MN	C	H				X@N&M			
NO	C	V	X						
OP	T	H							
PQ	T	H							
QR	T	H							
RS	T	H		X					
ST	T	H							
TU	T	H							
UV	T	H							
VW	T	H		X					
WX	T	H							
XY	T	H							
YZ	T	H		X					
ZA	T	H							
BZ	T	D	X					X	
ZC	C	V				X@C			
CY	T	D				X@C			
YD	C	V		X		X@D			
DX	T	D				X@D			
XE	C	V			X				
EW	T	D				X@E			
WF	C	V			X				
FV	T	D							
VG	C	V	X						
GU	T	D							
UH	C	V							
UI	T	D							
IT	C	V							
TJ	T	D							
JS	C	V							
SK	T	D							
KR	C	V							
RL	T	D							
LQ	C	V							
QM	T	D				X@M			
MP	C	V	X						
PN	T	D		X		X@N			

* Accessibility during repair may require removing an external wood siding for all highlighted members.

Table A7: The Inspection of Area A, Column Line: 25 1/2

Member	T/C	H/V/D	Ls	Ss	R	Es*	Bsc	D	Remarks
AB	C	V	X			X@B			Minor leak from ceiling
BC	C	H							Minor leak from ceiling
CD	C	H							
DE	C	H							
EF	C	H							
FG	C	H							
GH	C	H							
HI	C	H							
IJ	C	H							
JK	C	H		X					
KL	C	H							
LM	C	H							
MN	C	H		X					
NO	C	V				X@N			
OP	T	H							
PQ	T	H							Supports air ventilation equipment
QR	T	H							
RS	T	H							
ST	T	H							
TU	T	H							
UV	T	H							
VW	T	H							
WX	T	H		X					
XY	T	H							
YZ	T	H							
ZA	T	H							
BZ	T	D		X		X@B			
ZC	C	V							
CY	T	D	X						
YD	C	V	X						
DX	T	D			X				
XE	C	V							
EW	T	D							
WF	C	V							
FV	T	D							
VG	C	V		X					
GU	T	D							
UH	C	V							
UI	T	D							
IT	C	V	X						
TJ	T	D							
JS	C	V							
SK	T	D							
KR	C	V							
RL	T	D							
LQ	C	V							
QM	T	D							
MP	C	V		X		X@M			
PN	T	D		X					

* Accessibility during repair may require removing an external wood siding for all highlighted members.

Table A8: The Inspection of Area A, Column Line: 26

Member	T/C	H/V/D	Ls	Ss	R	Es*	Bsc	D	Remarks
AB	C	V	X			X@B			Exposed to leakage
BC	C	H				X@B			
CD	C	H							
DE	C	H		X					
EF	C	H							
FG	C	H							
GH	C	H							
HI	C	H							
IJ	C	H	X						
JK	C	H							
KL	C	H							
LM	C	H							
MN	C	H				X@N			
NO	C	V	X						
OP	T	H							
PQ	T	H							
QR	T	H							
RS	T	H		X					
ST	T	H							
TU	T	H							
UV	T	H		X					Air condition is supported by UV
VW	T	H							
WX	T	H							
XY	T	H							
YZ	T	H							
ZA	T	H							
BZ	T	D						D	
ZC	C	V	X		X				
CY	T	D							
YD	C	V			X				
DX	T	D							
XE	C	V							
EW	T	D							
WF	C	V	X						
FV	T	D							
VG	C	V							
GU	T	D							
UH	C	V							
UI	T	D							
IT	C	V							
TJ	T	D		X					
JS	C	V							
SK	T	D							
KR	C	V							
RL	T	D							
LQ	C	V		X					
QM	T	D							
MP	C	V		X					
PN	T	D				X@N			

* Accessibility during repair may require removing an external wood siding for all highlighted members.

Table A9: The Inspection of Area A, Column Line: 26 1/2

Member	T/C	H/V/D	Ls	Ss	R	Es*	Bsc	D	Remarks
AB	C	V	X			X@B			Exposed to minor leakage
BC	C	H				X@B			
CD	C	H				X@C&D			
DE	C	H							
EF	C	H							
FG	C	H							
GH	C	H							
HI	C	H		X					
IJ	C	H							
JK	C	H							
KL	C	H							
LM	C	H							Supports ~12" dia. Pipe
MN	C	H				X@N			
NO	C	V	X						
OP	T	H							
PQ	T	H							
QR	T	H							
RS	T	H							
ST	T	H		X					
TU	T	H							
UV	T	H							
VW	T	H							
WX	T	H							
XY	T	H							
YZ	T	H				X@Z		X	
ZA	T	H							
BZ	T	D	X						
ZC	C	V		X					
CY	T	D							
YD	C	V			X				
DX	T	D							
XE	C	V							
EW	T	D							
WF	C	V							
FV	T	D							
VG	C	V	X		X				
GU	T	D							
UH	C	V		X					
UI	T	D							
IT	C	V							
TJ	T	D							
JS	C	V							
SK	T	D		X					
KR	C	V							
RL	T	D							
LQ	C	V		X					
QM	T	D							
MP	C	V		X					Pipe is resting on MP&NP joint
PN	T	D		X		X@N			

* Accessibility during repair may require removing an external wood siding for all highlighted members.

Table A10: The Inspection of Area A, Column Line: 27

Member	T/C	H/V/D	Ls	Ss	R	Es*	Bsc	D	Remarks
AB	C	V				X@B			
BC	C	H							
CD	C	H							
DE	C	H							
EF	C	H		X					
FG	C	H							
GH	C	H							
HI	C	H							
IJ	C	H							
JK	C	H							
KL	C	H				X@L			
LM	C	H							
MN	C	H							
NO	C	V	X						
OP	T	H							Supports ~6" dia. Pipe
PQ	T	H							
QR	T	H							
RS	T	H							
ST	T	H		X					
TU	T	H							
UV	T	H							
VW	T	H							
WX	T	H							
XY	T	H							
YZ	T	H							
ZA	T	H							
BZ	T	D	X						Fractured
ZC	C	V	X						
CY	T	D		X					
YD	C	V		X					
DX	T	D							
XE	C	V							
EW	T	D							
WF	C	V							
FV	T	D							
VG	C	V	X						
GU	T	D							
UH	C	V							
UI	T	D							
IT	C	V	X						
TJ	T	D							
JS	C	V							
SK	T	D	X						
KR	C	V							
RL	T	D				X@L			
LQ	C	V	X						
QM	T	D							Fractured
MP	C	V	X						
PN	T	D							Supports two ~6" diameter pipes

* Accessibility during repair may require removing an external wood siding for all highlighted members.

Table A11: The Inspection of Area A, Column Line: 27 1/2

Member	T/C	H/V/D	Ls	Ss	R	Es*	Bsc	D	Remarks
AB	C	V	X						
BC	C	H	X						
CD	C	H							
DE	C	H							
EF	C	H							
FG	C	H							
GH	C	H							
HI	C	H							
IJ	C	H							
JK	C	H							
KL	C	H							
LM	C	H							
MN	C	H							
NO	C	V	X						
OP	T	H							
PQ	T	H							
QR	T	H							
RS	T	H							
ST	T	H							
TU	T	H		X					
UV	T	H							
VW	T	H							
WX	T	H							
XY	T	H							
YZ	T	H							
ZA	T	H							
BZ	T	D							
ZC	C	V		X					
CY	T	D							
YD	C	V							
DX	T	D							
XE	C	V							
EW	T	D							
WF	C	V							
FV	T	D							
VG	C	V							
GU	T	D							
UH	C	V							
UI	T	D							
IT	C	V							
TJ	T	D							
JS	C	V			X				
SK	T	D							
KR	C	V							
RL	T	D							
LQ	C	V		X					
QM	T	D							
MP	C	V		X					
PN	T	D							

Table A12: The Inspection of Area A, Column Line: 28

Member	T/C	H/V/D	Ls	Ss	R	Es*	Bsc	D	Remarks
AB	C	V				X@B			
BC	C	H							
CD	C	H							
DE	C	H							
EF	C	H							
FG	C	H	X						
GH	C	H	X						
HI	C	H							
IJ	C	H							
JK	C	H							
KL	C	H	X						
LM	C	H							
MN	C	H							
NO	C	V			X				
OP	T	H							
PQ	T	H							
QR	T	H							
RS	T	H							
ST	T	H							
TU	T	H							
UV	T	H							
VW	T	H							
WX	T	H							
XY	T	H							
YZ	T	H							
ZA	T	H							
BZ	T	D				X@B			
ZC	C	V			X				
CY	T	D			X				Repaired by tension rod
YD	C	V			X				
DX	T	D				X@D			
XE	C	V							
EW	T	D							
WF	C	V							
FV	T	D							
VG	C	V		X					
GU	T	D							
UH	C	V	X						
UI	T	D							
IT	C	V							
TJ	T	D							
JS	C	V							
SK	T	D							
KR	C	V							
RL	T	D							
LQ	C	V							
QM	T	D							
MP	C	V	X						
PN	T	D							

* Accessibility during repair may require removing an external wood siding for all highlighted members.

Table A13: The Inspection of Area A, Column Line: 28 1/2

Member	T/C	H/V/D	Ls	Ss	R	Es*	Bsc	D	Remarks
AB	C	V	X			X@B			
BC	C	H	X						
CD	C	H	X						
DE	C	H	X						
EF	C	H							
FG	C	H							
GH	C	H							
HI	C	H							
IJ	C	H							
JK	C	H							
KL	C	H		X					
LM	C	H							
MN	C	H							
NO	C	V	X			X@N			
OP	T	H							
PQ	T	H							
QR	T	H							
RS	T	H		X					
ST	T	H							
TU	T	H							
UV	T	H							
VW	T	H							
WX	T	H							
XY	T	H							
YZ	T	H	X						
ZA	T	H							
BZ	T	D				X@B&Z			
ZC	C	V				X@Z			
CY	T	D							
YD	C	V			X	X@D			
DX	T	D							
XE	C	V							
EW	T	D							
WF	C	V							
FV	T	D	X						
VG	C	V			X				
GU	T	D							
UH	C	V		X					
UI	T	D							
IT	C	V		X					
TJ	T	D							
JS	C	V							
SK	T	D							
KR	C	V		X					
RL	T	D							
LQ	C	V		X					
QM	T	D							
MP	C	V			X				
PN	T	D				X@N			

* Accessibility during repair may require removing an external wood siding for all highlighted members.

Table A14: The Inspection of Area A, Column Line: 29

Member	T/C	H/V/D	Ls	Ss	R	Es*	Bsc	D	Remarks
AB	C	V	X			X@B			
BC	C	H							
CD	C	H							
DE	C	H		X					
EF	C	H							
FG	C	H							
GH	C	H							
HI	C	H							
IJ	C	H							
JK	C	H							
KL	C	H		X					
LM	C	H							
MN	C	H		X					
NO	C	V		X					
OP	T	H							
PQ	T	H							
QR	T	H							
RS	T	H							
ST	T	H							
TU	T	H		X					
UV	T	H							
VW	T	H							
WX	T	H		X					
XY	T	H							
YZ	T	H							
ZA	T	H							
BZ	T	D		X		X@B			
ZC	C	V		X		X@C			Large split on upper section of ZC
CY	T	D							
YD	C	V			X				
DX	T	D							
XE	C	V							
EW	T	D							
WF	C	V							
FV	T	D							
VG	C	V		X					
GU	T	D							
UH	C	V							
UI	T	D							
IT	C	V						X	
TJ	T	D						X	Severe decay on upper part of TJ
JS	C	V				X@J			
SK	T	D							
KR	C	V	X						
RL	T	D							
LQ	C	V			X				
QM	T	D						X	
MP	C	V			X				
PN	T	D				X@N			

* Accessibility during repair may require removing an external wood siding for all highlighted members.

Table A15: The Inspection of Area A, Column Line: 29 1/2

Member	T/C	H/V/D	Ls	Ss	R	Es*	Bsc	D	Remarks
AB	C	V	X			X@B			
BC	C	H							
CD	C	H							
DE	C	H							
EF	C	H							
FG	C	H							
GH	C	H							
HI	C	H							
IJ	C	H							
JK	C	H							Purlin on joint K is severely decayed
KL	C	H							
LM	C	H							
MN	C	H							
NO	C	V	X			X@N			
OP	T	H							
PQ	T	H							
QR	T	H		X					
RS	T	H							
ST	T	H							
TU	T	H							
UV	T	H		X					
VW	T	H							
WX	T	H							
XY	T	H							
YZ	T	H							
ZA	T	H							
BZ	T	D				X@B			
ZC	C	V	X			X@B			
CY	T	D		X					Fractured
YD	C	V		X					
DX	T	D							
XE	C	V				X@E			
EW	T	D							
WF	C	V		X					
FV	T	D							
VG	C	V		X					
GU	T	D							
UH	C	V							
UI	T	D							
IT	C	V							
TJ	T	D							
JS	C	V							
SK	T	D						X@K	
KR	C	V							
RL	T	D							
LQ	C	V							
QM	T	D				X@M		X@M	
MP	C	V							
PN	T	D				X@N			

* Accessibility during repair may require removing an external wood siding for all highlighted members.

Table 16: The Inspection of Area A, Column Line: 30

Member	T/C	H/V/D	Ls	Ss	R	Es*	Bsc	D	Remarks
AB	C	V		X		X@B			
BC	C	H	X						
CD	C	H	X						
DE	C	H							
EF	C	H							
FG	C	H		X					
GH	C	H							
HI	C	H							
IJ	C	H							
JK	C	H							
KL	C	H		X					
LM	C	H							
MN	C	H							
NO	C	V	X			X@N			
OP	T	H							
PQ	T	H							
QR	T	H							
RS	T	H							
ST	T	H							Catwalk is placed along E-W direction
TU	T	H							
UV	T	H							
VW	T	H		X					
WX	T	H							
XY	T	H							
YZ	T	H				X@Z			
ZA	T	H							
BZ	T	D		X		X@B@Z			
ZC	C	V		X					
CY	T	D							
YD	C	V		X					
DX	T	D							
XE	C	V							
EW	T	D							
WF	C	V			X				
FV	T	D							
VG	C	V			X				
GU	T	D							
UH	C	V							
UI	T	D							
IT	C	V	X						
TJ	T	D							
JS	C	V							
SK	T	D							
KR	C	V							
RL	T	D							
LQ	C	V							
QM	T	D							
MP	C	V			X				
PN	T	D				X@N			

* Accessibility during repair may require removing an external wood siding for all highlighted members.

Table A17: The Inspection of Area A, Column Line: 30 1/2

Member	T/C	H/V/D	Ls	Ss	R	Es*	Bsc	D	Remarks
AB	C	V	X			X@B			
BC	C	H							
CD	C	H							
DE	C	H	X						
EF	C	H	X						
FG	C	H							
GH	C	H		X					
HI	C	H							
IJ	C	H							
JK	C	H							Purlin on K is decayed and bent
KL	C	H							
LM	C	H							
MN	C	H							
NO	C	V	X			X@N			
OP	T	H							
PQ	T	H							
QR	T	H		X					
RS	T	H							
ST	T	H							
TU	T	H							
UV	T	H							
VW	T	H							
WX	T	H							
XY	T	H							
YZ	T	H							
ZA	T	H							
BZ	T	D		X		X@B&Z			
ZC	C	V			X				
CY	T	D							
YD	C	V		X					
DX	T	D							
XE	C	V		X					
EW	T	D							
WF	C	V		X					
FV	T	D							
VG	C	V							
GU	T	D							
UH	C	V	X						
UI	T	D							
IT	C	V							
TJ	T	D							
JS	C	V							
SK	T	D							
KR	C	V							
RL	T	D							
LQ	C	V							
QM	T	D						X	
MP	C	V			X				
PN	T	D				X@N			

* Accessibility during repair may require removing an external wood siding for all highlighted members.

Table A18: The Inspection of Area A, Column Line: 31

Member	T/C	H/V/D	Ls	Ss	R	Es*	Bsc	D	Remarks
AB	C	V	X						
BC	C	H							
CD	C	H							
DE	C	H							
EF	C	H		X					
FG	C	H							
GH	C	H							
HI	C	H							
IJ	C	H							
JK	C	H							
KL	C	H							
LM	C	H						X	
MN	C	H		X					
NO	C	V	X						
OP	T	H							
PQ	T	H							
QR	T	H							
RS	T	H							
ST	T	H							
TU	T	H							
UV	T	H							
VW	T	H							
WX	T	H							
XY	T	H							
YZ	T	H							
ZA	T	H							
BZ	T	D				X@B			
ZC	C	V		X	X				
CY	T	D							
YD	C	V		X					
DX	T	D							
XE	C	V							
EW	T	D							
WF	C	V							
FV	T	D						X@V	
VG	C	V							
GU	T	D							
UH	C	V							
UI	T	D							
IT	C	V			X				
TJ	T	D							
JS	C	V			X				
SK	T	D							
KR	C	V							
RL	T	D							
LQ	C	V							
QM	T	D				X@M		X	
MP	C	V							
PN	T	D				X@N			

* Accessibility during repair may require removing an external wood siding for all highlighted members.

Table A19: The Inspection of Area A, Column Line: 31 1/2

Member	T/C	H/V/D	Ls	Ss	R	Es*	Bsc	D	Remarks
AB	C	V	X			X@B			
BC	C	H							
CD	C	H							
DE	C	H	X						
EF	C	H							
FG	C	H							
GH	C	H							
HI	C	H							
IJ	C	H							
JK	C	H							
KL	C	H		X					
LM	C	H							
MN	C	H							
NO	C	V							
OP	T	H				X@O			
PQ	T	H							
QR	T	H							
RS	T	H							
ST	T	H							
TU	T	H		X					
UV	T	H							
VW	T	H							
WX	T	H							
XY	T	H							
YZ	T	H							
ZA	T	H							
BZ	T	D		X					
ZC	C	V	X						
CY	T	D							
YD	C	V							
DX	T	D							
XE	C	V							
EW	T	D							
WF	C	V							
FV	T	D							
VG	C	V							
GU	T	D							
UH	C	V			X				
UI	T	D							
IT	C	V							
TJ	T	D							
JS	C	V			X				
SK	T	D							
KR	C	V			X				
RL	T	D							
LQ	C	V			X				
QM	T	D							
MP	C	V			X				
PN	T	D				X@N			

* Accessibility during repair may require removing an external wood siding for all highlighted members.

Table A20: The Inspection of Area A, Column Line: 32

Member	T/C	H/V/D	Ls	Ss	R	Es*	Bsc	D	Remarks
AB	C	V	X						
BC	C	H							
CD	C	H							
DE	C	H							
EF	C	H							
FG	C	H							
GH	C	H				X@H			
HI	C	H							
IJ	C	H							
JK	C	H							
KL	C	H							
LM	C	H							
MN	C	H				X@N			
NO	C	V	X						
OP	T	H							
PQ	T	H							
QR	T	H							
RS	T	H		X					
ST	T	H							
TU	T	H							
UV	T	H		X					
VW	T	H							
WX	T	H							
XY	T	H							
YZ	T	H							
ZA	T	H							
BZ	T	D							
ZC	C	V		X					
CY	T	D							
YD	C	V							
DX	T	D							
XE	C	V							
EW	T	D							
WF	C	V							
FV	T	D							
VG	C	V							
GU	T	D							
UH	C	V	X		X				
UI	T	D							
IT	C	V							
TJ	T	D							
JS	C	V			X				
SK	T	D							
KR	C	V							
RL	T	D							
LQ	C	V			X				
QM	T	D							
MP	C	V							
PN	T	D				X@N			

* Accessibility during repair may require removing an external wood siding for all highlighted members.

Table A21: The Inspection of Area A, Column Line: 32 1/2

Member	T/C	H/V/D	Ls	Ss	R	Es*	Bsc	D	Remarks
AB	C	V	X						
BC	C	H		X					
CD	C	H							
DE	C	H							
EF	C	H							
FG	C	H							
GH	C	H							
HI	C	H							
IJ	C	H							
JK	C	H						X	
KL	C	H							
LM	C	H							
MN	C	H							
NO	C	V	X						
OP	T	H							
PQ	T	H							
QR	T	H							
RS	T	H		X					
ST	T	H							
TU	T	H							
UV	T	H		X					
VW	T	H					X		
WX	T	H							
XY	T	H							
YZ	T	H							
ZA	T	H							
BZ	T	D		X		X@B			
ZC	C	V		X					
CY	T	D						X	
YD	C	V		X					
DX	T	D							
XE	C	V							
EW	T	D							
WF	C	V							
FV	T	D							
VG	C	V		X					
GU	T	D							
UH	C	V	X		X				
UI	T	D							
IT	C	V							
TJ	T	D							
JS	C	V							
SK	T	D							
KR	C	V							
RL	T	D							
LQ	C	V			X				
QM	T	D							
MP	C	V							
PN	T	D		X		X@N			

* Accessibility during repair may require removing an external wood siding for all highlighted members.

Table A22: The Inspection of Area A, Column Line: 33

Member	T/C	H/V/D	Ls	Ss	R	Es*	Bsc	D	Remarks
AB	C	V	X						
BC	C	H		X					
CD	C	H	X						
DE	C	H		X					
EF	C	H							
FG	C	H							
GH	C	H							
HI	C	H							
IJ	C	H							
JK	C	H							
KL	C	H							
LM	C	H						X	Serious. Purlins L&M decayed from leak
MN	C	H							
NO	C	V	X						
OP	T	H							
PQ	T	H							
QR	T	H							
RS	T	H		X					
ST	T	H							
TU	T	H							
UV	T	H							
VW	T	H					X		
WX	T	H							
XY	T	H							
YZ	T	H							
ZA	T	H							
BZ	T	D		X					
ZC	C	V	X						
CY	T	D				X@C			
YD	C	V				X@D			
DX	T	D						X	
XE	C	V							
EW	T	D							
WF	C	V							
FV	T	D							
VG	C	V							
GU	T	D							
UH	C	V	X			X@H			
UI	T	D							
IT	C	V							
TJ	T	D							
JS	C	V							
SK	T	D							
KR	C	V							
RL	T	D							
LQ	C	V			X				
QM	T	D							
MP	C	V							
PN	T	D				X@N			

* Accessibility during repair may require removing an external wood siding for all highlighted members.

Table A23: The Inspection of Area A, Column Line: 33 1/2

Member	T/C	H/V/D	Ls	Ss	R	Es*	Bsc	D	Remarks
AB	C	V	X						
BC	C	H							
CD	C	H							
DE	C	H							
EF	C	H					X		
FG	C	H							
GH	C	H							
HI	C	H							
IJ	C	H							
JK	C	H							
KL	C	H							
LM	C	H							
MN	C	H							
NO	C	V		X					
OP	T	H							
PQ	T	H							
QR	T	H		X					
RS	T	H							
ST	T	H							
TU	T	H							
UV	T	H							
VW	T	H							
WX	T	H		X					
XY	T	H							
YZ	T	H							
ZA	T	H							
BZ	T	D				X@B			
ZC	C	V		X					
CY	T	D							
YD	C	V							
DX	T	D							
XE	C	V							
EW	T	D							
WF	C	V							
FV	T	D							
VG	C	V		X	X				
GU	T	D							
UH	C	V	X						
UI	T	D							
IT	C	V							
TJ	T	D						X	
JS	C	V							
SK	T	D				X@K		X	
KR	C	V							
RL	T	D							
LQ	C	V			X				
QM	T	D				X@M			
MP	C	V							
PN	T	D							

* Accessibility during repair may require removing an external wood siding for all highlighted members.

Table A24: The Inspection of Area A, Column Line: 34

Member	T/C	H/V/D	Ls	Ss	R	Es*	Bsc	D	Remarks
AB	C	V							
BC	C	H							
CD	C	H							
DE	C	H							
EF	C	H							
FG	C	H							
GH	C	H							
HI	C	H							
IJ	C	H							
JK	C	H							
KL	C	H							
LM	C	H							
MN	C	H							
NO	C	V							
OP	T	H							
PQ	T	H							
QR	T	H							
RS	T	H							
ST	T	H							
TU	T	H							
UV	T	H							
VW	T	H							
WX	T	H		X					
XY	T	H		X					
YZ	T	H		X					
ZA	T	H							
BZ	T	D		X		X@B			Fractured
ZC	C	V	X						
CY	T	D		X					Fractured
YD	C	V							
DX	T	D							
XE	C	V			X				
EW	T	D							
WF	C	V							
FV	T	D							
VG	C	V	X						
GU	T	D							
UH	C	V	X						
UI	T	D							
IT	C	V	X						
TJ	T	D							
JS	C	V							
SK	T	D							
KR	C	V			X				
RL	T	D							
LQ	C	V							
QM	T	D							
MP	C	V							
PN	T	D							

* Accessibility during repair may require removing an external wood siding for all highlighted members.

Table A25: The Inspection of Area A, Column Line: 34 1/2

Member	T/C	H/V/D	Ls	Ss	R	Es*	Bsc	D	Remarks
AB	C	V							
BC	C	H							
CD	C	H							
DE	C	H							
EF	C	H							
FG	C	H							
GH	C	H							
HI	C	H							
IJ	C	H							
JK	C	H							
KL	C	H		X				X	
LM	C	H							
MN	C	H							
NO	C	V							
OP	T	H							
PQ	T	H							
QR	T	H							
RS	T	H		X					
ST	T	H							
TU	T	H							
UV	T	H							
VW	T	H							
WX	T	H							
XY	T	H		X					
YZ	T	H							
ZA	T	H							
BZ	T	D				X@B&Z			
ZC	C	V		X					
CY	T	D		X					
YD	C	V							
DX	T	D							
XE	C	V	X		X				Outer member is repaired, inner is split
EW	T	D							
WF	C	V			X				
FV	T	D							
VG	C	V	X		X				Outer member is repaired, inner is split
GU	T	D							
UH	C	V			X				
UI	T	D							
IT	C	V		X					
TJ	T	D							
JS	C	V							
SK	T	D							
KR	C	V							
RL	T	D							
LQ	C	V			X				
QM	T	D				X@M			
MP	C	V			X				
PN	T	D				X@N			

* Accessibility during repair may require removing an external wood siding for all highlighted members.

Table A26: The Inspection of Area A, Column Line: 35

Member	T/C	H/V/D	Ls	Ss	R	Es*	Bsc	D	Remarks
AB	C	V	X						
BC	C	H							
CD	C	H							
DE	C	H							
EF	C	H							
FG	C	H	X						
GH	C	H							
HI	C	H							
IJ	C	H							
JK	C	H							
KL	C	H							
LM	C	H							
MN	C	H	X						
NO	C	V	X						
OP	T	H							
PQ	T	H							
QR	T	H							
RS	T	H		X					
ST	T	H							
TU	T	H							
UV	T	H							
VW	T	H							
WX	T	H							
XY	T	H							
YZ	T	H							
ZA	T	H							
BZ	T	D				X@B			
ZC	C	V							
CY	T	D		X		X@C			
YD	C	V		X					
DX	T	D							
XE	C	V							
EW	T	D							
WF	C	V							
FV	T	D							
VG	C	V							
GU	T	D							
UH	C	V	X		X				Outer member is repaired, inner is split
UI	T	D							
IT	C	V							
TJ	T	D							
JS	C	V							
SK	T	D							
KR	C	V							
RL	T	D							
LQ	C	V							
QM	T	D							
MP	C	V							
PN	T	D				X@N			

* Accessibility during repair may require removing an external wood siding for all highlighted members.

Table A27: The Inspection of Area A, Column Line: 35 1/2

Member	T/C	H/V/D	Ls	Ss	R	Es*	Bsc	D	Remarks
AB	C	V							
BC	C	H							
CD	C	H					X		
DE	C	H							
EF	C	H					X		
FG	C	H							
GH	C	H							
HI	C	H							
IJ	C	H							
JK	C	H							
KL	C	H							
LM	C	H							
MN	C	H		X					
NO	C	V	X						
OP	T	H							
PQ	T	H							
QR	T	H							
RS	T	H							
ST	T	H		X					
TU	T	H							
UV	T	H							
VW	T	H							
WX	T	H							
XY	T	H							
YZ	T	H							
ZA	T	H							
BZ	T	D				X@B			
ZC	C	V	X						
CY	T	D							
YD	C	V							
DX	T	D							
XE	C	V			X				
EW	T	D							
WF	C	V					X		
FV	T	D							
VG	C	V			X				
GU	T	D							
UH	C	V							
UI	T	D							
IT	C	V							
TJ	T	D							
JS	C	V							
SK	T	D							
KR	C	V							
RL	T	D							
LQ	C	V							
QM	T	D							
MP	C	V							
PN	T	D	X			X@N			

- Accessibility during repair may require removing an external wood siding for all highlighted members.

Table A28: The Inspection of Area A, Column Line: 36

Member	T/C	H/V/D	Ls	Ss	R	Es*	Bsc	D	Remarks
AB	C	V	X						
BC	C	H	X						
CD	C	H							
DE	C	H	X						
EF	C	H							
FG	C	H							
GH	C	H							
HI	C	H							
IJ	C	H							
JK	C	H							
KL	C	H		X					
LM	C	H					X		
MN	C	H							
NO	C	V		X					
OP	T	H							
PQ	T	H							
QR	T	H							
RS	T	H		X					
ST	T	H							
TU	T	H							
UV	T	H		X					
VW	T	H							
WX	T	H							
XY	T	H							
YZ	T	H							
ZA	T	H							
BZ	T	D				X@B			
ZC	C	V	X						
CY	T	D		X				X	
YD	C	V							
DX	T	D	X						Fractured
XE	C	V							
EW	T	D							
WF	C	V							
FV	T	D							
VG	C	V	X						
GU	T	D							
UH	C	V		X					
UI	T	D							
IT	C	V							
TJ	T	D							
JS	C	V							
SK	T	D							
KR	C	V							
RL	T	D							
LQ	C	V							
QM	T	D							
MP	C	V			X				
PN	T	D							

* Accessibility during repair may require removing an external wood siding for all highlighted members.

Table A29: The Inspection of Area A, Column Line: 36 1/2

Member	T/C	H/V/D	Ls	Ss	R	Es*	Bsc	D	Remarks
AB	C	V							
BC	C	H							
CD	C	H							
DE	C	H							
EF	C	H							
FG	C	H							
GH	C	H							
HI	C	H							
IJ	C	H							
JK	C	H							
KL	C	H							
LM	C	H							
MN	C	H							
NO	C	V							
OP	T	H							
PQ	T	H							
QR	T	H							
RS	T	H							
ST	T	H							
TU	T	H							
UV	T	H							
VW	T	H							
WX	T	H							
XY	T	H							
YZ	T	H		X					
ZA	T	H	X						
BZ	T	D				X@B		X	Decay in lower section of BZ
ZC	C	V			X	X@C			
CY	T	D							
YD	C	V				X@D			
DX	T	D							
XE	C	V			X				
EW	T	D							
WF	C	V		X					
FV	T	D							
VG	C	V							
GU	T	D							
UH	C	V		X					
UI	T	D							
IT	C	V							
TJ	T	D							
JS	C	V							
SK	T	D							
KR	C	V							
RL	T	D							
LQ	C	V							
QM	T	D							Fractured
MP	C	V							
PN	T	D							

* Accessibility during repair may require removing an external wood siding for all highlighted members.

Table A30: The Inspection of Area A, Column Line: 37

Member	T/C	H/V/D	Ls	Ss	R	Es*	Bsc	D	Remarks
AB	C	V	X						
BC	C	H		X					
CD	C	H							
DE	C	H							
EF	C	H							
FG	C	H		X					
GH	C	H							
HI	C	H							
IJ	C	H							
JK	C	H							
KL	C	H							
LM	C	H							
MN	C	H							
NO	C	V							
OP	T	H							
PQ	T	H							
QR	T	H							
RS	T	H							
ST	T	H							
TU	T	H							
UV	T	H							
VW	T	H							
WX	T	H							
XY	T	H							
YZ	T	H							
ZA	T	H							
BZ	T	D							
ZC	C	V							
CY	T	D		X					
YD	C	V							
DX	T	D							
XE	C	V		X					
EW	T	D							
WF	C	V							
FV	T	D							
VG	C	V							
GU	T	D							
UH	C	V		X					
UI	T	D							
IT	C	V							
TJ	T	D							
JS	C	V							
SK	T	D							
KR	C	V							
RL	T	D							
LQ	C	V							
QM	T	D							
MP	C	V							
PN	T	D				X@N			

* Accessibility during repair may require removing an external wood siding for all highlighted members.

Table A31: The Inspection of Area A, Column Line: 37 1/2

Member	T/C	H/V/D	Ls	Ss	R	Es*	Bsc	D	Remarks
AB	C	V	X					X@B	Leakage
BC	C	H							
CD	C	H							
DE	C	H							
EF	C	H							
FG	C	H		X					
GH	C	H							
HI	C	H							
IJ	C	H							
JK	C	H							
KL	C	H							
LM	C	H							
MN	C	H							
NO	C	V							
OP	T	H							
PQ	T	H							
QR	T	H							
RS	T	H		X					
ST	T	H							
TU	T	H							
UV	T	H		X					
VW	T	H							
WX	T	H							
XY	T	H							
YZ	T	H							
ZA	T	H							
BZ	T	D				X@B		X@B	
ZC	C	V							
CY	T	D	X						
YD	C	V	X						
DX	T	D			X				
XE	C	V							
EW	T	D							
WF	C	V							
FV	T	D							
VG	C	V							
GU	T	D							
UH	C	V							
UI	T	D							
IT	C	V							
TJ	T	D							
JS	C	V							
SK	T	D							
KR	C	V							
RL	T	D							
LQ	C	V			X				
QM	T	D							
MP	C	V			X				
PN	T	D							

* Accessibility during repair may require removing an external wood siding for all highlighted members.

Table A32: The Inspection of Area A, Column Line: 38

Member	T/C	H/V/D	Ls	Ss	R	Es*	Bsc	D	Remarks
AB	C	V	X					X	Damage form Leakage from ceiling and sides
BC	C	H	X					X	
CD	C	H							
DE	C	H							
EF	C	H		X					
FG	C	H							
GH	C	H							
HI	C	H							
IJ	C	H							
JK	C	H							
KL	C	H							
LM	C	H							
MN	C	H		X					
NO	C	V				X@N		X	
OP	T	H							
PQ	T	H							
QR	T	H							
RS	T	H							
ST	T	H							
TU	T	H							
UV	T	H							
VW	T	H							
WX	T	H							
XY	T	H							
YZ	T	H							
ZA	T	H							
BZ	T	D				X@B		X	Leakage from ceiling, & Fractured
ZC	C	V		X					
CY	T	D	X					X	
YD	C	V			X				
DX	T	D							
XE	C	V		X					
EW	T	D							
WF	C	V							
FV	T	D							
VG	C	V			X				
GU	T	D							
UH	C	V			X				
UI	T	D							
IT	C	V							
TJ	T	D							
JS	C	V							
SK	T	D							
KR	C	V							
RL	T	D							
LQ	C	V							
QM	T	D							
MP	C	V	X						
PN	T	D							Fractured

* Accessibility during repair may require removing an external wood siding for all highlighted members.

Appendix B: Inspection Tables for Area B

Table B1: The Inspection of Area B, Column Line: 39, Section CA

Member	T/C	H/V/D	Ls	Ss	R	Es	Bsc	D	Remarks
CT	T	D		X					
QG	C	V				X @ G			
HP	T	V						D	

Column line 39 to 45 are exposed to chemical. Minor Decay is observed

Table B2: The Inspection of Area B, Column Line: 40, Section CA

Member	T/C	H/V/D	Ls	Ss	R	Es	Bsc	D	Remarks
NO	T	H		X					
OP	T	H		X					
QR	T	H		X					
RS	T	H		X					
ST	T	H		X					
IO	C	V		X					

Multiple pipes are supported by diagonal chords along the E-W direction.

Table B3: The Inspection of Area B, Column Line: 42, Section CA

Member	T/C	H/V/D	Ls	Ss	R	Es	Bsc	D	Remarks
KL	C	V	X					X	
ER	T	D	X						
OJ	T	D	X						

Table B4: The Inspection of Area B, Column Line: 43, Section CA

Member	T/C	H/V/D	Ls	Ss	R	Es	Bsc	D	Remarks
KL	C	V			X				
LN	T	H		X					
NO	T	H		X					
OP	T	H		X					

Minor cracks along top & lower horizontal chords.

Table B5: The Inspection of Area B, Column Line: 44, Section CA

Member	T/C	H/V/D	Ls	Ss	R	Es	Bsc	D	Remarks
KL	C	V			X				
LN	T	H			X				
OP	T	H			X				New member is provided on South side
PQ	T	H			X				New member is provided on South side
QR	T	H			X				New member is provided on South side
PI	T	D	X						
OJ	T	D			X				
NK	T	D			X				

Table B6: The Inspection of Area B, Column Line: 46, Section CA

Member	T/C	H/V/D	Ls	Ss	R	Es	Bsc	D	Remarks
TD	C	V		X					
SE	C	V		X					
FQ	T	D		X					
QH	T	D		X				X	
NK	T	D		X					

Table B7: The Inspection of Area B, Column Line: 47, Section CA

Member	T/C	H/V/D	Ls	Ss	R	Es	Bsc	D	Remarks
CT	T	D		X					
TD	C	V	X						
DS	T	D		X					
SE	C	V		X					
NK	T	D		X					

Table B8: The Inspection of Area B, Column Line: 48, Section CA

Member	T/C	H/V/D	Ls	Ss	R	Es	Bsc	D	Remarks
TD	C	V		X					

Table B9: The Inspection of Area B, Column Line: 49, Section CA

Member	T/C	H/V/D	Ls	Ss	R	Es	Bsc	D	Remarks
DS	T	D		X					
ER	T	D		X					
QG	C	V	X						
HP	T	V		X					
OJ	T	D	X						

Table B10: The Inspection of Area B, Column Line: 50, Section CA

Member	T/C	H/V/D	Ls	Ss	R	Es	Bsc	D	Remarks
TD	C	V		X					
QG	C	V						X	
HP	T	V		X					
OJ	T	D		X					

Table B11: The Inspection of Area B, Column Line: 51, Section CA

Member	T/C	H/V/D	Ls	Ss	R	Es	Bsc	D	Remarks
CT	T	D	X					X	
SE	C	V		X					
ER	T	D	X						
HP	T	V		X		X @ P			
IO	C	V		X		X @ O			

Table B12: The Inspection of Area B, Column Line: 53, Section CA

Member	T/C	H/V/D	Ls	Ss	R	Es	Bsc	D	Remarks
DS	T	D		X					
RF	C	V	X						
PI	T	D		X					
JN	C	V				X @ N			

Table B13: The Inspection of Area B, Column Line: 54, Section CA

Member	T/C	H/V/D	Ls	Ss	R	Es	Bsc	D	Remarks
LN	T	H		X					
CT	T	D				X @ T			
DS	T	D		X					
ER	T	D				X @ R			
RF	C	V	X						
NK	T	D				X @ N			

Table B14: The Inspection of Area B, Column Line: 55, Section CA

Member	T/C	H/V/D	Ls	Ss	R	Es	Bsc	D	Remarks
CT	T	D				X @ T			
DS	T	D		X					
HP	T	V		X					
IO	C	V		X					
NK	T	D				X @ N			

Table B15: The Inspection of Area B, Column Line: 56, Section CA

Member	T/C	H/V/D	Ls	Ss	R	Es	Bsc	D	Remarks
FG	C	H		X					
GH	C	H		X					
DS	T	D	X						
ER	T	D		X					
RF	C	V		X					
PI	T	D		X					
NK	T	D	X						

Table B16: The Inspection of Area B, Column Line: 57, Section CA

Member	T/C	H/V/D	Ls	Ss	R	Es	Bsc	D	Remarks
FG	C	H		X					
GH	C	H	X						
LN	T	H						X	
NO	T	H						X	
RS	T	H		X					
ST	T	H		X					
TB	T	H		X					
DS	T	D		X					
PI	T	D	X						

Table B17: The Inspection of Area B, Column Line: 61, Section CA

Member	T/C	H/V/D	Ls	Ss	R	Es	Bsc	D	Remarks
FG	C	H							Purlin on G is cracked
GH	C	H							Purlin on H is cracked
HI	C	H							Purlin on I is cracked

Column line 61 is covered by a dropped ceiling

Table B18: The Inspection of Area B, Column Line: 62, Section CA

Member	T/C	H/V/D	Ls	Ss	R	Es	Bsc	D	Remarks
KL	C	V		X					
SE	C	V		X					
RF	C	V		X					
QG	C	V	X			X @ Q			
HP	T	V		X					
OJ	T	D		X					
JN	C	V		X					

Table B19: The Inspection of Area B, Column Line: 63, Section CA

Member	T/C	H/V/D	Ls	Ss	R	Es	Bsc	D	Remarks
DE	C	H							Purlin on E is cracked through 64
HI	C	H							Purlin is cracked
IJ	C	H							Purlin on I is cracked
FQ	T	D		X					
QH	T	D		X					
HP	T	V		X					
PI	T	D	X						

Table B20: The Inspection of Area B, Column Line: 39, Section EC

Member	T/C	H/V/D	Ls	Ss	R	Es	Bsc	D	Remarks
TD	C	V			X				Stitch bolt is provided
DS	T	D				X @ S			
ER	T	D			X	X @ R		X	Joint R is decayed & fractured
OJ	T	D	X						

Table B21: The Inspection of Area B, Column Line: 40, Section EC

Member	T/C	H/V/D	Ls	Ss	R	Es	Bsc	D	Remarks
EF	C	H		X					
FG	C	H		X					
IO	C	V			X				Stitch bolt is provided
JN	C	V			X				

Table B22: The Inspection of Area B, Column Line: 41, Section EC

Member	T/C	H/V/D	Ls	Ss	R	Es	Bsc	D	Remarks
CT	T	D				X @ T			
IO	C	V			X	X @ O			Stitch bolt is provided
JN	C	V				X @ N			

Table B23: The Inspection of Area B, Column Line: 42, Section EC

Member	T/C	H/V/D	Ls	Ss	R	Es	Bsc	D	Remarks
BC	C	V	X						
ST	T	H						X	
TB	T	H						X	
SE	C	V			X				Steel rod is provided
RF	C	V		X					
QH	T	D			X				
JN	C	V			X				Steel rod is provided

Table B24: The Inspection of Area B, Column Line: 43, Section EC

Member	T/C	H/V/D	Ls	Ss	R	Es	Bsc	D	Remarks
DE	C	H		X					
FG	C	H		X					
HI	C	H		X					
IJ	C	H		X					
JK	C	H		X					
RS	T	H		X					
ST	T	H		X					
TB	T	H		X					
TD	C	V	X						
QG	C	V			X				Stitch bolt is provided
PI	T	D			X				Steel rod is provided
JN	C	V				X @ N			

Table B25: The Inspection of Area B, Column Line: 44, Section EC

Member	T/C	H/V/D	Ls	Ss	R	Es	Bsc	D	Remarks
BC	C	V	X						
CT	T	D		X					
DS	T	D		X		X@S			
IO	C	V				X@O			

Table B26: The Inspection of Area B, Column Line: 46, Section EC

Member	T/C	H/V/D	Ls	Ss	R	Es	Bsc	D	Remarks
OP	T	H		X					
CT	T	D				X@T			
DS	T	D				X@S			
ER	T	D		X					
RF	C	V		X					
QG	C	V	X						
PI	T	D		X					
IO	C	V		X					
OJ	T	D	X						
NK	T	D				X@N			

Table B27: The Inspection of Area B, Column Line: 47, Section EC

Member	T/C	H/V/D	Ls	Ss	R	Es	Bsc	D	Remarks
ST	T	H		X					
TD	C	V		X					
HP	T	V		X					

Table B28: The Inspection of Area B, Column Line: 48, Section EC

Member	T/C	H/V/D	Ls	Ss	R	Es	Bsc	D	Remarks
QR	T	H		X					
ST	T	H		X					
TB	T	H		X					
CT	T	D		X					
ER	T	D		X					
RF	C	V		X					
QH	T	D		X					
OJ	T	D		X					
NK	T	D		X		X@N			

Table B29: The Inspection of Area B, Column Line: 49, Section EC

Member	T/C	H/V/D	Ls	Ss	R	Es	Bsc	D	Remarks
RS	T	H		X					
ST	T	H		X					
TB	T	H		X					
CT	T	D		X					
ER	T	D		X					
RF	C	V							Chord RF is bent
QG	C	V				X@G			
QH	T	D		X		X@Q			
HP	T	V		X					

Table B30: The Inspection of Area B, Column Line: 50, Section EC

Member	T/C	H/V/D	Ls	Ss	R	Es	Bsc	D	Remarks
LN	T	H		X					
NO	T	H		X					
DS	T	D		X					
HP	T	V		X					
IO	C	V				X@O			
OJ	T	D		X					
JN	C	V				X@N			

Table B31: The Inspection of Area B, Column Line: 51, Section EC

Member	T/C	H/V/D	Ls	Ss	R	Es	Bsc	D	Remarks
IJ	C	H		X				X	
JK	C	H		X					
NO	T	H						X	
OP	T	H						X	
TD	C	V		X					
DS	T	D				X@S			
RF	C	V		X					
FQ	T	D		X					
QG	C	V	X						
QH	T	D		X					
OJ	T	D						X	
JN	C	V		X					
NK	T	D	X						

Table B32: The Inspection of Area B, Column Line: 53, Section EC

Member	T/C	H/V/D	Ls	Ss	R	Es	Bsc	D	Remarks
TD	C	V		X					
SE	C	V	X						
ER	T	D						X	
QG	C	V				X@Q			
QH	T	D		X					
JN	C	V		X					

Table B33: The Inspection of Area B, Column Line: 54, Section EC

Member	T/C	H/V/D	Ls	Ss	R	Es	Bsc	D	Remarks
KL	C	V		X					
CT	T	D		X					
DS	T	D		X					
SE	C	V	X						
ER	T	D		X					
RF	C	V	X						
IO	C	V				X@O			
JN	C	V				X@N			

Table B34: The Inspection of Area B, Column Line: 55, Section EC

Member	T/C	H/V/D	Ls	Ss	R	Es	Bsc	D	Remarks
BC	C	V		X					
CT	T	D		X					
RF	C	V	X						
QG	C	V	X			X @ G			

Table B35: The Inspection of Area B, Column Line: 56, Section EC

Member	T/C	H/V/D	Ls	Ss	R	Es	Bsc	D	Remarks
PQ	T	H		X					
DS	T	D		X					
RF	C	V		X					
FQ	T	D		X					
IO	C	V	X						
NK	T	D	X						

Table B36: The Inspection of Area B, Column Line: 60, Section EC

Member	T/C	H/V/D	Ls	Ss	R	Es	Bsc	D	Remarks
HI	C	H		X					
IJ	C	H							Purlin on J is cracked
RF	C	V		X					
HP	T	V		X		X @ H			

Column line 60 is covered by a dropped ceiling, but inspection has been performed using boom lift.

Table B37: The Inspection of Area B, Column Line: 61, Section EC

Member	T/C	H/V/D	Ls	Ss	R	Es	Bsc	D	Remarks
EF	C	H							Purlins on E & F are cracked
GH	C	H		X				X	
HP	T	V		X					

Table B38: The Inspection of Area B, Column Line: 62, Section EC

Member	T/C	H/V/D	Ls	Ss	R	Es	Bsc	D	Remarks
SE	C	V		X					
ER	T	D		X					
FQ	T	D		X				X	
QH	T	D		X					

Table B39: The Inspection of Area B, Column Line: 63, Section EC

Member	T/C	H/V/D	Ls	Ss	R	Es	Bsc	D	Remarks
FG	C	H							Purlin on G is cracked
IJ	C	H			X				
JK	C	H			X				
KL	C	V			X				
LN	T	H			X				
NO	T	H			X				
PI	T	D			X				
OJ	T	D			X				
JN	C	V			X				
NK	T	D			X				

Purlins on column line 62 to 64 are required to be inspected and repaired.

Table B40: The Inspection of Area B, Column Line: 39, Section GE

Member	T/C	H/V/D	Ls	Ss	R	Es	Bsc	D	Remarks
CT	T	D				X @ T			
TD	C	V			X				Stitch bolt is provided
DS	T	D			X				Steel rod is provided
ER	T	D			X				Steel rod is provided
RF	C	V		X					
QH	T	D	X						
PI	T	D			X				Steel rod is provided
OJ	T	D			X				Steel rod is provided
NK	T	D		X					

Table B41: The Inspection of Area B, Column Line: 40, Section GE

Member	T/C	H/V/D	Ls	Ss	R	Es	Bsc	D	Remarks
CT	T	D				X @ T			
RF	C	V		X					
FQ	T	D		X					
QH	T	D		X		X @ H			
IO	C	V		X					
JN	C	V				X @ N			

Table B42: The Inspection of Area B, Column Line: 47, Section GE

Member	T/C	H/V/D	Ls	Ss	R	Es	Bsc	D	Remarks
SE	C	V	X						
RF	C	V	X					X	Decayed and fractured
FQ	T	D	X					X	Decayed and fractured
QG	C	V		X					
IO	C	V	X						

Table B43: The Inspection of Area B, Column Line: 48, Section GE

Member	T/C	H/V/D	Ls	Ss	R	Es	Bsc	D	Remarks
QR	T	H		X				X	
RS	T	H		X				X	
ST	T	H		X				X	
TB	T	H				X @ B			
CT	T	D		X					
TD	C	V		X					
SE	C	V		X					
ER	T	D				X @ R			
PI	T	D		X					
OJ	T	D		X					
NK	T	D				X @ N			

Table B44: The Inspection of Area B, Column Line: 49, Section GE

Member	T/C	H/V/D	Ls	Ss	R	Es	Bsc	D	Remarks
ST	T	H						X	
TB	T	H						X	
TD	C	V						X	
SE	C	V		X					

Table B45: The Inspection of Area B, Column Line: 50, Section GE

Member	T/C	H/V/D	Ls	Ss	R	Es	Bsc	D	Remarks
CT	T	D		X					
PI	T	D		X					
OJ	T	D		X					
NK	T	D	X						

Table B46: The Inspection of Area B, Column Line: 51, Section GE

Member	T/C	H/V/D	Ls	Ss	R	Es	Bsc	D	Remarks
BC	C	V		X					
CT	T	D				X @ T			
DS	T	D				X @ S			
QH	T	D		X					
NK	T	D				X @ N			

Table B47: The Inspection of Area B, Column Line: 53, Section GE

Member	T/C	H/V/D	Ls	Ss	R	Es	Bsc	D	Remarks
TD	C	V		X					
ER	T	D						X	
FQ	T	D		X				X	
QG	C	V		X					
QH	T	D		X					
PI	T	D	X						
IO	C	V				X @ O			
OJ	T	D				X @ J			
NK	T	D				X @ N			

Table B48: The Inspection of Area B, Column Line: 54, Section GE

Member	T/C	H/V/D	Ls	Ss	R	Es	Bsc	D	Remarks
OP	T	H						X	
SE	C	V		X					
RF	C	V		X					
QH	T	D		X					
IO	C	V			X				Steel rod is provided

Table B49: The Inspection of Area B, Column Line: 55, Section GE

Member	T/C	H/V/D	Ls	Ss	R	Es	Bsc	D	Remarks
DS	T	D		X					
ER	T	D				X @ R			
QH	T	D		X					
PI	T	D				X @ I			
IO	C	V				X @ I			
OJ	T	D				X @ O			

Table B50: The Inspection of Area B, Column Line: 56, Section GE

Member	T/C	H/V/D	Ls	Ss	R	Es	Bsc	D	Remarks
SE	C	V		X		X @ E			
ER	T	D						X	
HP	T	V		X					
OJ	T	D		X					

Table B51: The Inspection of Area B, Column Line: 57, Section GE

Member	T/C	H/V/D	Ls	Ss	R	Es	Bsc	D	Remarks
BC	C	V		X					
RS	T	H						X	
CT	T	D		X					
SE	C	V				X @ E			
QH	T	D		X					
HP	T	V				X @ P			
IO	C	V				X @ O			

Table B52: The Inspection of Area B, Column Line: 58, Section GE

Member	T/C	H/V/D	Ls	Ss	R	Es	Bsc	D	Remarks
CT	T	D		X					
DS	T	D				X @ S			
ER	T	D				X @ R			
IO	C	V				X @ O			
OJ	T	D				X @ J			

Side of truss is covered by a wooden panel wall.

Table B53: The Inspection of Area B, Column Line: 59, Section GE

Member	T/C	H/V/D	Ls	Ss	R	Es	Bsc	D	Remarks
LN	T	H		X					
NO	T	H		X					
CT	T	D		X					
DS	T	D		X					
ER	T	D		X		X @ R			
QG	C	V				X @ G			
QH	T	D	X						
PI	T	D				X @ I			
IO	C	V	X						

Table B54: The Inspection of Area B, Column Line: 60, Section GE

Member	T/C	H/V/D	Ls	Ss	R	Es	Bsc	D	Remarks
HI	C	H		X					
CT	T	D		X					
DS	T	D		X					
ER	T	D		X					
RF	C	V		X					
QG	C	V		X					
QH	T	D						X	
HP	T	V				X @ P			
OJ	T	D		X					
NK	T	D				X @ N			

Table B55: The Inspection of Area B, Column Line: 61, Section GE

Member	T/C	H/V/D	Ls	Ss	R	Es	Bsc	D	Remarks
IJ	C	H							Purlin on top is cracked
RS	T	H						X	
ST	T	H						X	
TB	T	H						X	
PI	T	D						X	
OJ	T	D				X @ O			
JN	C	V				X @ J			

Table B56: The Inspection of Area B, Column Line: 62, Section GE

Member	T/C	H/V/D	Ls	Ss	R	Es	Bsc	D	Remarks
DE	C	H							Purlin on E is cracked
FG	C	H							Purlin on G is cracked
DS	T	D				X @ S			
SE	C	V				X @ E			
FQ	T	D				X @ Q			
QG	C	V				X @ G			Joint Q is decayed

Table B57: The Inspection of Area B, Column Line: 63, Section GE

Member	T/C	H/V/D	Ls	Ss	R	Es	Bsc	D	Remarks
BC	C	V							Purlin on C is cracked
CD	C	H							Purlin on C is cracked
DE	C	H							Purlin on E is cracked
EF	C	H							Purlin on F is cracked
HI	C	H							Purlin on H is cracked
IJ	C	H		X					
JK	C	H		X					
FQ	T	D						X	
QG	C	V							Significant decay at joint Q
NK	T	D	X						

Table B58: The Inspection of Area B, Column Line: 39, Section IG

Member	T/C	H/V/D	Ls	Ss	R	Es	Bsc	D	Remarks
GH	C	H		X					
DS	T	D		X					
ER	T	D			X				Steel rod is provided
FQ	T	D						X	
QG	C	V		X		X@Q			
QH	T	D		X		X@Q&H			H is not accessible
HP	T	V		X		X@H&P			H is not accessible
PI	T	D			X				Steel rod is provided for repair
IO	C	V				X @ O			
OJ	T	D				X @ O			
NK	T	D				X @ N			

Table B59: The Inspection of Area B, Column Line: 40, Section IG

Member	T/C	H/V/D	Ls	Ss	R	Es	Bsc	D	Remarks
JK	C	H	X						Fracture at mid section
ER	T	D			X				Steel rod is provided
FQ	T	D	X						
PI	T	D			X				Steel rod is provided
OJ	T	D				X @ J			

Table B60: The Inspection of Area B, Column Line: 46, Section IG

Member	T/C	H/V/D	Ls	Ss	R	Es	Bsc	D	Remarks
CT	T	D				X @ T			
ER	T	D		X					
FQ	T	D		X		X @ Q			
QH	T	D				X @ Q			
PI	T	D			X				Steel rod is provided
NK	T	D				X @ N			

Table B61: The Inspection of Area B, Column Line: 47, Section IG

Member	T/C	H/V/D	Ls	Ss	R	Es	Bsc	D	Remarks
NO	T	H		X					
RS	T	H						X	Decay due to chemical deterioration
SE	C	V	X						
PI	T	D				X @ P			
OJ	T	D		X					
NK	T	D				X @ N			

Column line 47 to 51 are exposed to chemicals, some of chord members have decayed

Table B62: The Inspection of Area B, Column Line: 48, Section IG

Member	T/C	H/V/D	Ls	Ss	R	Es	Bsc	D	Remarks
CT	T	D				X @ T			
ER	T	D			X				Steel rod is provided
RF	C	V			X	X @ R			Stitch bolts are provided
FQ	T	D				X @ Q			
QG	C	V				X @ Q			
QH	T	D		X					
IO	C	V				X @ O			
OJ	T	D				X @ J			
NK	T	D	X						

Table B63: The Inspection of Area B, Column Line: 49, Section IG

Member	T/C	H/V/D	Ls	Ss	R	Es	Bsc	D	Remarks
HI	C	H		X					
JK	C	H		X					
NO	T	H						X	
OP	T	H						X	
PQ	T	H						X	
TD	C	V	X						
DS	T	D						X	
ER	T	D			X				Steel rod is provided
RF	C	V	X						
HP	T	V				X @ P			
IO	C	V				X @ O			
OJ	T	D		X					

Table B64: The Inspection of Area B, Column Line: 50, Section IG

Member	T/C	H/V/D	Ls	Ss	R	Es	Bsc	D	Remarks
BC	C	V							Experienced leakage from ceiling
CD	C	H							Experienced leakage from ceiling
DE	C	H							Experienced leakage from ceiling
EF	C	H							Experienced leakage from ceiling
CT	T	D				X @ T			
TD	C	V				X @ T			
DS	T	D				X @ S			
RF	C	V			X				Stitch bolts are provided
PI	T	D			X				Steel rod is provided

Table B65: The Inspection of Area B, Column Line: 51, Section IG

Member	T/C	H/V/D	Ls	Ss	R	Es	Bsc	D	Remarks
BC	C	V							Experienced leakage from ceiling
CD	C	H	X						Experienced leakage from ceiling
DE	C	H	X						Experienced leakage from ceiling
EF	C	H	X						Experienced leakage from ceiling
FG	C	H							Experienced leakage from ceiling
PQ	T	H	X						
RS	T	H		X					
ST	T	H		X					
TD	C	V			X				
SE	C	V			X				Stitch bolts are provided
ER	T	D			X				Steel rod are provided
PI	T	D	X					X	
IO	C	V				X @ O			
JN	C	V				X @ N			
NK	T	D				X @ N			

Bottom of the east side of column 51 is split.

Table B66: The Inspection of Area B, Column Line: 53, Section IG

Member	T/C	H/V/D	Ls	Ss	R	Es	Bsc	D	Remarks
CD	C	H		X					
CT	T	D				X @ T			
DS	T	D			X				Steel rod is provided
SE	C	V	X			X @ S			
PI	T	D	X					X	
OJ	T	D			X				Steel rod is provided

Table B67: The Inspection of Area B, Column Line: 54, Section IG

Member	T/C	H/V/D	Ls	Ss	R	Es	Bsc	D	Remarks
CT	T	D				X@T			
DS	T	D				X@S			
FQ	T	D						X	
QG	C	V		X					
QH	T	D						X	
IO	C	V		X		X@O			

Table B68: The Inspection of Area B, Column Line: 55, Section IG

Member	T/C	H/V/D	Ls	Ss	R	Es	Bsc	D	Remarks
CT	T	D				X@T			
HP	T	V		X		X@P			
PI	T	D						X	
IO	C	V		X					
NK	T	D		X					

Table B69: The Inspection of Area B, Column Line: 56, Section IG

Member	T/C	H/V/D	Ls	Ss	R	Es	Bsc	D	Remarks
CT	T	D		X					
DS	T	D					X@S		
ER	T	D		X					
QG	C	V	X						
IO	C	V					X@O		
NK	T	D		X					

Table B70: The Inspection of Area B, Column Line: 57, Section IG

Member	T/C	H/V/D	Ls	Ss	R	Es	Bsc	D	Remarks
GH	C	H		X					
RS	T	H		X					
ST	T	H		X					
TD	C	V		X					
DS	T	D			X				Steel rod is provided
HP	T	V		X					
IO	C	V				X@O			
OJ	T	D			X				Steel rod is provided
JN	C	V		X					

Table B71: The Inspection of Area B, Column Line: 58, Section IG

Member	T/C	H/V/D	Ls	Ss	R	Es	Bsc	D	Remarks
GH	C	H		X					
HI	C	H		X					
NO	T	H		X					
DS	T	D		X					
SE	C	V		X					
FQ	T	D			X				Steel rod is provided
PI	T	D		X					

Table B72: The Inspection of Area B, Column Line: 59, Section IG

Member	T/C	H/V/D	Ls	Ss	R	Es	Bsc	D	Remarks
HI	C	H						X	Minor decay observed
IJ	C	H						X	Minor decay observed
JK	C	H						X	Minor decay observed
RS	T	H		X					
ST	T	H	X						
TB	T	H	X						
CT	T	D			X				Steel rod is provided
DS	T	D			X				Steel rod is provided
SE	C	V		X				X	
ER	T	D				X @ R			
QH	T	D			X				Steel rod is provided
PI	T	D		X					

Table B73: The Inspection of Area B, Column Line: 60, Section IG

Member	T/C	H/V/D	Ls	Ss	R	Es	Bsc	D	Remarks
DS	T	D		X					
QH	T	D		X					
PI	T	D		X	X				Steel rod is provided

Table B74: The Inspection of Area B, Column Line: 61, Section IG

Member	T/C	H/V/D	Ls	Ss	R	Es	Bsc	D	Remarks
FG	C	H	X						
HI	C	H		X					
SE	C	V		X					
RF	C	V		X					
QH	T	D		X					
NK	T	D	X						Split on lower member

Table B75: The Inspection of Area B, Column Line: 62, Section IG

Member	T/C	H/V/D	Ls	Ss	R	Es	Bsc	D	Remarks
DE	C	H		X					
EF	C	H		X					

Table B76: The Inspection of Area B, Column Line: 63, Section IG

Member	T/C	H/V/D	Ls	Ss	R	Es	Bsc	D	Remarks
CT	T	D	X						Fracture on lower section
SE	C	V		X					
QH	T	D		X					
PI	T	D			X				Steel rod is provided
OJ	T	D			X				Steel rod is provided
NK	T	D			X				Steel rod is provided

Appendix C: Inspection Tables for Area C

Table C1: The Inspection of Area C, Column Line: 46

Member	T/C	H/V/D	Ls	Ss	R	Es	Bsc	D	Remarks
GH	C	H						X	
BD	C	D				X@B			
VE	C	V				X@E			
SI	T	D		X					
RJ	T	D	X						
QK	T	D				X@Q			
OM	T	D				X@O			

Table C2: The Inspection of Area C, Column Line: 47

Member	T/C	H/V/D	Ls	Ss	R	Es	Bsc	D	Remarks
VE	C	V			X				
UF	C	V			X				
SH	C	V	X						
JQ	C	V				X@Q			
PL	T	D	X						
OM	T	D	X			X@O			

Table C3: The Inspection of Area C, Column Line: 48

Member	T/C	H/V/D	Ls	Ss	R	Es	Bsc	D	Remarks
JK	C	H	X						
KL	C	H	X						
DW	C	V						X	
DV	T	D				X@V			
VE	C	V	X						
TG	C	V	X						
SH	C	V		X					
SI	T	D	X						
IR	C	V		X					
JQ	C	V	X						
LO	C	V			X				
OM	T	D		X					

Table C4: The Inspection of Area C, Column Line: 49

Member	T/C	H/V/D	Ls	Ss	R	Es	Bsc	D	Remarks
VE	C	V		X					
UF	C	V		X					
SH	C	V	X						
SI	T	D		X					
IR	C	V	X						
PL	T	D				X@P			
OM	T	D		X		X@O			

Table C5: The Inspection of Area C, Column Line: 50

Member	T/C	H/V/D	Ls	Ss	R	Es	Bsc	D	Remarks
DV	T	D				X@V			
VE	C	V		X					
GS	T	D		X					
SH	C	V		X					
SI	T	D		X					
JQ	C	V				X@Q			
KP	C	V				X@P			

Table C6: The Inspection of Area C, Column Line: 51

Member	T/C	H/V/D	Ls	Ss	R	Es	Bsc	D	Remarks
DW	C	V		X					
UF	C	V		X					
FT	T	D		X					
TG	C	V		X					
GS	T	D							Lower portion of chord GS is fractured
SH	C	V				X@S			
SI	T	D		X					
IR	C	V				X@R			
JQ	C	V		X					
QK	T	D				X@Q			
KP	C	V				X@P			
OM	T	D				X@O			

Table C7: The Inspection of Area C, Column Line: 53

Member	T/C	H/V/D	Ls	Ss	R	Es	Bsc	D	Remarks
OP	T	H	X						
PQ	T	H	X						
QR	T	H	X						
EU	T	D		X					
IR	C	V		X					
KP	C	V		X					
PL	T	D				X@P			
LO	C	V		X					
OM	T	D		X		X@O			

Column 53-A shows severe decay and is rusting at the base plate.

Table C8: The Inspection of Area C, Column Line: 54

Member	T/C	H/V/D	Ls	Ss	R	Es	Bsc	D	Remarks
DW	C	V				X@W			
UF	C	V		X					
TG	C	V		X					
PL	T	D				X@P			
LO	C	V	X						
OM	T	D				X@O			

Table C9: The Inspection of Area C, Column Line: 55

Member	T/C	H/V/D	Ls	Ss	R	Es	Bsc	D	Remarks
DV	T	D		X					
EU	T	D		X					
FT	T	D	X						
TG	C	V	X						
GS	T	D		X					
SH	C	V		X					
SI	T	D		X					
RJ	T	D		X					
QK	T	D		X					
KP	C	V		X					
PL	T	D		X					
OM	T	D		X					

Table C10: The Inspection of Area C, Column Line: 56

Member	T/C	H/V/D	Ls	Ss	R	Es	Bsc	D	Remarks
MN	C	V		X					
OP	T	H	X						
PQ	T	H	X						
BD	C	D		X					
DW	C	V				X@W			
DV	T	D				X@V			
VE	C	V		X					
EU	T	D		X					
TG	C	V		X					
SI	T	D	X						
RJ	T	D	X						
PL	T	D		X					
LO	C	V	X						
OM	T	D	X						

Table C11: The Inspection of Area C, Column Line: 57

Member	T/C	H/V/D	Ls	Ss	R	Es	Bsc	D	Remarks
GS	T	D		X					
SI	T	D		X					

Column line 57 is covered by a wall.

Table C12: The Inspection of Area C, Column Line: 62

Member	T/C	H/V/D	Ls	Ss	R	Es	Bsc	D	Remarks
GH	C	H		X					
RJ	T	D		X					

Column line is covered by a dropped ceiling.

Table C13: The Inspection of Area C, Column Line: 63

Member	T/C	H/V/D	Ls	Ss	R	Es	Bsc	D	Remarks
CD	C	H		X					
DE	C	H		X					
EF	C	H		X					
FG	C	H		X					
GH	C	H		X					
HI	C	H		X					
IJ	C	H		X					
JK	C	H		X					
KL	C	H		X					
LM	C	H		X					
DW	C	V	X						
DV	T	D	X						
EU	T	D	X						
IR	C	V	X						
RJ	T	D		X					
QK	T	D		X					
LO	C	V	X						

Appendix D: Inspection Tables for Area D

Table D1: The Inspection of Area D, Column Line: 46

Member	T/C	H/V/D	Ls	Ss	R	Es	Bsc	D	Remarks
DE	C	H						X	
EF	C	H						X	
FG	C	H						X	
JK	C	H						X	Experienced leakage from ceiling
KL	C	H						X	
NO	T	H						X	Experienced leakage from ceiling
OP	T	H						X	Experienced leakage from ceiling
PQ	T	H						X	Experienced leakage from ceiling
ST	T	H	X						
CW	C	D				X @ W			
DW	C	V		X					
DV	T	D				X @ V			
FT	T	D				X @ T			
SI	T	D						X	
QK	T	D						X	
PL	T	D						X	
OM	T	D						X	

Column line 46 has experienced leakage through the ceiling.

Table D2: The Inspection of Area D, Column Line: 47

Member	T/C	H/V/D	Ls	Ss	R	Es	Bsc	D	Remarks
FG	C	H						X	
CW	C	D				X @ W			
VE	C	V		X					
EU	T	D				X @ U			
FT	T	D				X @ T			
SI	T	D		X					
PL	T	D				X @ P			
OM	T	D				X @ O			

Table D3: The Inspection of Area D, Column Line: 48

Member	T/C	H/V/D	Ls	Ss	R	Es	Bsc	D	Remarks
GH	C	H		X					
HI	C	H		X					
CW	C	D				X @ C			
DV	T	D	X			X @ D			
VE	C	V				X @ V			
EU	T	D				X @ U			
IR	C	V	X						
RJ	T	D		X					
JQ	C	V		X					
QK	T	D		X					
KP	C	V		X		X @ P			

Table D4: The Inspection of Area D, Column Line: 49

Member	T/C	H/V/D	Ls	Ss	R	Es	Bsc	D	Remarks
CD	C	H		X					
HI	C	H						X	
IJ	C	H						X	
MN	C	V						X	
NO	T	H						X	
OP	T	H						X	
PQ	T	H						X	
QR	T	H						X	
RS	T	H						X	
DV	T	D		X					
EU	T	D		X					
FT	T	D		X					
GS	T	D		X					

Column line 49 has experienced severe damage from leakage.
 A hollow column supports column line 49 directly under SH.

Table D5: The Inspection of Area D, Column Line: 50

Member	T/C	H/V/D	Ls	Ss	R	Es	Bsc	D	Remarks
KL	C	H						X	
LM	C	H						X	
CW	C	D				X@W			
DW	C	V				X@D			
DV	T	D				X@V			
VE	C	V	X						
FT	T	D				X@T			Joint T is decayed
SH	C	V	X						
SI	T	D	X						
OM	T	D				X@O			

Table D6: The Inspection of Area D, Column Line: 51

Member	T/C	H/V/D	Ls	Ss	R	Es	Bsc	D	Remarks
GH	C	H						X	Leakage damage from ceiling
HI	C	H						X	Leakage damage from ceiling
IJ	C	H						X	Leakage damage from ceiling
JK	C	H						X	Leakage damage from ceiling
KL	C	H						X	Leakage damage from ceiling
LM	C	H						X	Leakage damage from ceiling
NO	T	H						X	Leakage damage from ceiling
OP	T	H						X	Leakage damage from ceiling
PQ	T	H						X	Leakage damage from ceiling
QR	T	H						X	Leakage damage from ceiling
RS	T	H						X	Leakage damage from ceiling
ST	T	H						X	Leakage damage from ceiling
CW	C	D		X					
DV	T	D	X			X@V			
IR	C	V		X					
LO	C	V		X					
OM	T	D		X					

Table D7: The Inspection of Area D, Column Line: 53

Member	T/C	H/V/D	Ls	Ss	R	Es	Bsc	D	Remarks
BC	C	V		X					
DV	T	D				X@V			
VE	C	V		X					
EU	T	D				X@U			
FT	T	D		X					
SH	C	V	X						
JQ	C	V				X@Q			
QK	T	D				X@Q			
PL	T	D				X@P			
OM	T	D				X@O			

Table D8: The Inspection of Area D, Column Line: 54

Member	T/C	H/V/D	Ls	Ss	R	Es	Bsc	D	Remarks
DV	T	D				X@V			
EU	T	D				X@U			
SH	C	V	X						

Column line 54 is hidden by a wall beginning at chord IR, hiding the chords to the East.

Table D9: The Inspection of Area D, Column Line: 55

Member	T/C	H/V/D	Ls	Ss	R	Es	Bsc	D	Remarks
CW	C	D		X					
DW	C	V		X					
DV	T	D				X@V			
VE	C	V		X					
EU	T	D		X					
SI	T	D				X@S			
RJ	T	D				X@R			

Column line 55 is hidden by a wall beginning at chord IR, hiding the chords to the East.

Table D10: The Inspection of Area D, Column Line: 56

Member	T/C	H/V/D	Ls	Ss	R	Es	Bsc	D	Remarks
CW	C	D				X@W			
DV	T	D				X@V			
UF	C	V		X					
FT	T	D		X					
GS	T	D						X	
SH	C	V	X			X@S			

Column line 56 is partially hidden by a wall.

Table D11: The Inspection of Area D, Column Line: 62

Member	T/C	H/V/D	Ls	Ss	R	Es	Bsc	D	Remarks
BC	C	V	X						
EF	C	H							Purlin is cracked at F
FG	C	H							Purlin is cracked at F
IJ	C	H							Water leak along IJ
JK	C	H							Water leak along JK
KL	C	H							Minor cracking at L
LM	C	H							Minor cracking at L
CW	C	D		X					
DW	C	V		X					
DV	T	D		X					
VE	C	V	X						
EU	T	D		X					
FT	T	D		X					
GS	T	D		X		X @ G			
SH	C	V	X			X @ H			
SI	T	D		X					
IR	C	V		X					
QK	T	D		X					
KP	C	V		X					

Column line 58 through 64 are covered by a dropped ceiling.
 Inspection has been performed using boom lift.

Table D12: The Inspection of Area D, Column Line: 63

Member	T/C	H/V/D	Ls	Ss	R	Es	Bsc	D	Remarks
RJ	T	D		X					
JQ	C	V		X					
QK	T	D		X					
KP	C	V		X					

Column line 58 through 64 are covered by a dropped ceiling.
 Inspection has been performed using boom lift.

Appendix E: SAP90 Input and Output

STRUCTURAL ANALYSIS PROGRAMS

VERSION 5.41

Copyright (C) 1978-1994
 EDWARD L. WILSON
 All rights reserved

Input:

c Wood Truss, Area A Sections 22-38
 c U.S.CERL c Apr. 27 1998
 c Load Combination=D.L+L.L+P.L system
 L=1

joints

1 x=0 y=0 z=0
 13 x=1200 y=0 g=1,13
 14 x=0 y=120
 20 x=600 y=144 g=14,20
 26 x=1200 y=120 g=20,26
 27 x=0 y=-288 z=0
 28 x=1200 y=-288 z=0
 29 x=0 y=-282 z=0
 30 x=1200 y=-282 z=0

restraints

27 r=1,1,1,1,1,1
 28 r=1,1,1,1,1,1

frame

nm=10 nl=3
 1 a=78.76 i=830.6 e=1860
 2 a=74.25 i=1128.0 e=1860
 3 a=63.25 i=697.1 e=1860
 4 a=52.25 i=393.0 e=1860
 5 a=30.25 i=76.26 e=1860
 6 a=56.26 i=593.2 e=1860
 7 a=36.26 i=158.8 e=1860
 8 a=18.13 i=79.4 e=1860
 9 a=180 i=3375 e=1860
 10 a=90 i=1687.5 e=1860
 1 wg=0, -0.0219, 0
 2 wg=0.047, 0, 0
 3 wg=0.0208, 0, 0
 1 1 2 m=1 lr=0,0,0,0,0,0 nsl=1 g=11,1,1,1
 13 14 15 m=1 lr=0,0,0,0,0,0 nsl=1 g=5,1,1,1
 19 20 21 m=1 lr=0,0,0,0,0,0 nsl=1 g=5,1,1,1
 25 1 14 m=2 lr=0,0,0,0,0,0
 26 2 15 m=2 lr=0,0,0,0,0,0
 27 3 16 m=3 lr=0,0,0,0,0,0
 28 4 17 m=3 lr=0,0,0,0,0,0
 29 5 18 m=4 lr=1,1,0,0,0,0
 30 6 19 m=5 lr=1,1,0,0,0,0
 31 7 20 m=5 lr=1,1,0,0,0,0
 32 8 21 m=5 lr=1,1,0,0,0,0
 33 9 22 m=4 lr=1,1,0,0,0,0
 34 10 23 m=3 lr=0,0,0,0,0,0
 35 11 24 m=3 lr=0,0,0,0,0,0
 36 12 25 m=2 lr=0,0,0,0,0,0
 37 13 26 m=2 lr=0,0,0,0,0,0
 38 14 2 m=6 lr=0,0,0,0,0,0
 39 15 3 m=6 lr=0,0,0,0,0,0
 40 16 4 m=6 lr=0,1,0,0,0,0
 41 17 5 m=6 lr=0,0,0,0,0,0
 42 18 6 m=7 lr=1,1,0,0,0,0
 43 19 7 m=8 lr=1,1,0,0,0,0
 44 7 21 m=8 lr=1,1,0,0,0,0
 45 8 22 m=7 lr=1,1,0,0,0,0
 46 9 23 m=6 lr=1,0,0,0,0,0
 47 10 24 m=6 lr=0,0,0,0,0,0
 48 11 25 m=6 lr=0,0,0,0,0,0
 49 12 26 m=6 lr=0,0,0,0,0,0
 50 29 1 m=9 lr=0,0,0,0,0,0
 51 30 13 m=9 lr=0,0,0,0,0,0
 52 27 29 m=10 lr=0,0,0,0,0,0
 53 28 30 m=10 lr=0,0,0,0,0,0

LOADS

2 12 1 L=1 f=0, -3, 0

Output:

CSI / SAP90 - - FINITE ELEMENT ANALYSIS
 OF STRUCTURES PAGE 1

PROGRAM:SAP90/FILE:trussa.F3F
 c Wood Truss, Area A Sections 22-38

FRAME ELEMENT FORCES

1-3 PLANE ID	COND	DIST			1-2 PLANE		AXIAL
		SHEAR	MOMENT	TORQ	SHEAR	MOMENT	FORCE
1	1	.000	.000	.000	4.019	-203.614	-2.012
		100.000	1.829	88.775			-2.012
2	1	.000	.000	.000	1.546	-27.796	29.482
		70.604	.000	26.789			
		100.000	-.644	17.327			29.482
3	1	.000	.000	.000	1.568	-30.411	54.251
		71.582	.000	25.697			
		100.000	-.622	16.854			54.251
4	1	.000	.000	.000	1.209	-11.019	71.905
		55.186	.000	22.330			
		100.000	-.981	.339			71.905
5	1	.000	.000	.000	1.182	-5.762	83.268
		53.953	.000	26.112			
		100.000	-1.008	2.894			83.268
6	1	.000	.000	.000	1.020	2.894	88.626
		46.558	.000	26.630			
		100.000	-1.170	-4.644			88.626
7	1	.000	.000	.000	1.162	-4.644	88.631
		53.060	.000	26.184			
		100.000	-1.028	2.058			88.631
8	1	.000	.000	.000	1.053	2.058	83.244
		48.098	.000	27.390			
		100.000	-1.137	-2.108			83.244
9	1	.000	.000	.000	.988	-2.108	71.925
		45.095	.000	20.160			
		100.000	-1.202	-12.849			71.925
10	1	.000	.000	.000	.575	20.452	54.241
		26.252	.000	27.999			
		100.000	-1.615	-31.555			54.241
11	1	.000	.000	.000	.654	16.575	29.482
		29.861	.000	26.339			
		100.000	-1.536	-27.529			29.482
12	1	.000	.000	.000	-1.831	88.906	-2.012

		100.000	-4.021	-203.652		.000	-1.325	90.643
		100.000		-2.012		124.000	-1.325	-73.630
13		-----						
	1	.000		-29.836		124.000		-32.947
		.000	1.906	-48.853		1	.000	-24.521
		87.168	.000	34.214		.000	-.620	39.497
		100.080	-.282	32.391		128.000	-.620	-39.864
		100.080		-29.748		128.000		-24.521
14		-----						
	1	.000		-55.330		1	.000	-17.116
		.000	1.911	-54.186		.000	-.389	27.873
		87.423	.000	29.368		132.000	-.389	-23.499
		100.080	-.277	27.616		132.000		-17.116
		100.080		-55.242				
15		-----						
	1	.000		-73.215		1	.000	-9.633
		.000	1.580	-27.384		.000	.000	.000
		72.261	.000	29.702		136.000	.000	.000
		100.080	-.608	21.241		136.000		-9.633
		100.080		-73.128				
16		-----						
	1	.000		-84.964		1	.000	-2.259
		.000	1.241	-16.527		.000	.000	.000
		56.751	.000	18.683		140.000	.000	.000
		100.080	-.947	-1.841		140.000		-2.259
		100.080		-84.876				
17		-----						
	1	.000		-90.324		1	.000	4.585
		.000	1.182	-1.841		.000	.000	.000
		54.063	.000	30.112		144.000	.000	.000
		100.080	-1.006	6.961		144.000		4.585
		100.080		-90.236				
18		-----						
	1	.000		-90.581		1	.000	-2.245
		.000	.864	6.961		.000	.000	.000
		39.494	.000	24.013		140.000	.000	.000
		100.080	-1.325	-16.117		140.000		-2.245
		100.080		-90.493				
19		-----						
	1	.000		-90.493		1	.000	-17.123
		.000	1.326	-16.117		.000	.373	-25.868
		60.655	.000	24.104		132.000	.373	23.379
		100.080	-.862	7.111		132.000		-17.123
		100.080		-90.581				
20		-----						
	1	.000		-90.241		1	.000	-24.453
		.000	1.000	7.111		.000	.613	-39.476
		45.746	.000	29.989		128.000	.613	39.014
		100.080	-1.188	-2.286		128.000		-24.453
		100.080		-90.329				
21		-----						
	1	.000		-84.852		1	.000	-32.959
		.000	.968	-2.286		.000	1.325	-90.584
		44.252	.000	19.123		124.000	1.325	73.759
		100.080	-1.221	-14.952		124.000		-32.959
		100.080		-84.939				
22		-----						
	1	.000		-73.164		1	.000	-38.759
		.000	.610	20.248		.000	-.434	72.888
		27.916	.000	28.768		120.000	-.434	20.848
		100.080	-1.578	-28.165		120.000		-38.759
		100.080		-73.252				
23		-----						
	1	.000		-55.240		1	.000	38.303
		.000	.256	29.139		.000	-.133	12.948
		11.700	.000	30.636		159.298	-.133	-8.241
		100.080	-1.932	-54.759		159.298		38.303
		100.080		-55.328				
24		-----						
	1	.000		-29.748		1	.000	27.924
		.000	.285	32.222		.000	-.093	15.136
		13.017	.000	34.074		162.432	-.093	.000
		100.080	-1.904	-48.795		162.432		27.924
		100.080		-29.835				
25		-----						
	1	.000		-38.761		1	.000	18.655
		.000	.434	-72.914		.000	-.123	14.270
		120.000	.434	-20.859		165.602	-.123	-6.101
		120.000		-38.761		165.602		18.655
26		-----						
	1	.000		-32.947		1	.000	9.045
						.000	.000	.000
						168.808	.000	.000
						168.808		9.045

43	-----			
	1	.000		.464
		.000	.000	.000
		172.047	.000	.000
		172.047		.464
44	-----			
	1	.000		.455
		.000	.000	.000
		172.047	.000	.000
		172.047		.455
45	-----			
	1	.000		9.093
		.000	.000	.000
		168.808	.000	.000
		168.808		9.093
46	-----			
	1	.000		18.650
		.000	.071	.000
		165.602	.071	11.821
		165.602		18.650
47	-----			
	1	.000		27.915
		.000	.158	-7.434
		162.432	.158	18.290
		162.432		27.915
48	-----			
	1	.000		38.293
		.000	.137	-8.655
		159.298	.137	13.221
		159.298		38.293
49	-----			
	1	.000		46.712
		.000	.344	-25.852
		156.205	.344	27.947
		156.205		46.712
50	-----			
	1	.000		-42.780
		.000	-1.578	168.538
		282.000	-1.578	-276.528
		282.000		-42.780
51	-----			
	1	.000		-42.780
		.000	1.578	-168.526
		282.000	1.578	276.540
		282.000		-42.780
52	-----			
	1	.000		-42.780
		.000	-1.578	178.007
		6.000	-1.578	168.538
		6.000		-42.780
53	-----			
	1	.000		-42.780
		.000	1.578	-177.996
		6.000	1.578	-168.526
		6.000		-42.780

STRUCTURAL ANALYSIS PROGRAMS

VERSION 5.41

Copyright (C) 1978-1994
 EDWARD L. WILSON
 All rights reserved

Input:

c Wood Truss, Area A Sections 22-38
 c U.S.CERL
 c Apr. 27 1998
 c Load Combination =D.L+W.L+P.L
 system
 I=1

joints

1 x=0 y=0 z=0
 13 x=1200 y=0 g=1,13
 14 x=0 y=120
 20 x=600 y=144 g=14,20
 26 x=1200 y=120 g=20,26
 27 x=0 y=-288 z=0
 28 x=1200 y=-288 z=0
 29 x=0 y=-282 z=0
 30 x=1200 y=-282 z=0

restraints

27 r=1,1,1,1,1,1
 28 r=1,1,1,1,1,1

frame

rm=10 nl=3
 1 a=78.76 i=830.6 e=1860
 2 a=74.25 i=1128.0 e=1860
 3 a=63.25 i=697.1 e=1860
 4 a=52.25 i=393.0 e=1860
 5 a=30.25 i=76.26 e=1860
 6 a=56.26 i=593.2 e=1860
 7 a=36.26 i=158.8 e=1860
 8 a=18.13 i=79.4 e=1860
 9 a=180 i=3375 e=1860
 10 a=90 i=1687.5 e=1860

1 wg=0,0,004125,0
 2 wg=0.047,0,0
 3 wg=0.0208,0,0

1	1	2	m=1	lr=0,0,0,0,0,0	nsl=1	g=11,1,1,1
13	14	15	m=1	lr=0,0,0,0,0,0	nsl=1	g=5,1,1,1
19	20	21	m=1	lr=0,0,0,0,0,0	nsl=1	g=5,1,1,1
25	1	14	m=2	lr=0,0,0,0,0,0	nsl=2	
26	2	15	m=2	lr=0,0,0,0,0,0		
27	3	16	m=3	lr=0,0,0,0,0,0		
28	4	17	m=3	lr=0,0,0,0,0,0		
29	5	18	m=4	lr=1,1,0,0,0,0		
30	6	19	m=5	lr=1,1,0,0,0,0		
31	7	20	m=5	lr=1,1,0,0,0,0		
32	8	21	m=5	lr=1,1,0,0,0,0		
33	9	22	m=4	lr=1,1,0,0,0,0		
34	10	23	m=3	lr=0,0,0,0,0,0		
35	11	24	m=3	lr=0,0,0,0,0,0		
36	12	25	m=2	lr=0,0,0,0,0,0		
37	13	26	m=2	lr=0,0,0,0,0,0		
38	14	2	m=6	lr=0,0,0,0,0,0		
39	15	3	m=6	lr=0,0,0,0,0,0		
40	16	4	m=6	lr=0,1,0,0,0,0		
41	17	5	m=6	lr=0,0,0,0,0,0		
42	18	6	m=7	lr=1,1,0,0,0,0		
43	19	7	m=8	lr=1,1,0,0,0,0		
44	7	21	m=8	lr=1,1,0,0,0,0		
45	8	22	m=7	lr=1,1,0,0,0,0		
46	9	23	m=6	lr=1,0,0,0,0,0		
47	10	24	m=6	lr=0,0,0,0,0,0		
48	11	25	m=6	lr=0,0,0,0,0,0		
49	12	26	m=6	lr=0,0,0,0,0,0		
50	29	1	m=9	lr=0,0,0,0,0,0	nsl=3	
51	30	13	m=9	lr=0,0,0,0,0,0	nsl=3	
52	27	29	m=10	lr=0,0,0,0,0,0	nsl=3	
53	28	30	m=10	lr=0,0,0,0,0,0	nsl=3	

LOADS

2 12 1 I=1 f=0,-3,0

Output:

CSI / SAP90 - - FINITE ELEMENT ANALYSIS
 OF STRUCTURES

PROGRAM:SAP90/FILE:trussa.F3F
 c Wood Truss, Area A Sections 22-38

FRAME ELEMENT FORCES

1-3 PLANE	ELT LOAD	DIST	1-2 PLANE		AXIAL
			SHEAR	MOMENT	
ID	COND	ENI	TORQ	FORCE	

1	1	.000			.447
		.000	-2.540	180.219	
		100.000	-2.128	-53.201	
		100.000			.447

2	1	.000			9.634
		.000	.281	-25.489	
		100.000	.694	23.236	
		100.000			9.634

3	1	.000			15.921
		.000	-.135	4.882	
		32.810	.000	2.662	
		100.000	.277	11.973	
		100.000			15.921

4	1	.000			20.196
		.000	-.180	5.850	
		43.554	.000	1.938	
		100.000	.233	8.509	
		100.000			20.196

5	1	.000			22.669
		.000	-.173	7.811	
		41.997	.000	4.174	
		100.000	.239	11.113	
		100.000			22.669

6	1	.000			23.416
		.000	-.255	11.113	
		61.723	.000	3.255	
		100.000	.158	6.277	
		100.000			23.416

7	1	.000			21.918
		.000	-.185	6.277	
		44.748	.000	2.147	
		100.000	.228	8.444	
		100.000			21.918

8	1	.000			19.545
		.000	-.214	8.444	

		51.938	.000	2.880	
		100.000	.198	7.644	
		100.000			19.545
9		-----			
	1	.000			15.391
		.000	-.241	7.644	
		58.413	.000	.607	
		100.000	.172	4.174	
		100.000			15.391
10		-----			
	1	.000			9.303
		.000	-.442	17.043	
		100.000	-.030	-6.547	
		100.000			9.303
11		-----			
	1	.000			.988
		.000	.070	2.511	
		100.000	.483	30.161	
		100.000			.988
12		-----			
	1	.000			-7.852
		.000	-4.501	128.417	
		100.000	-4.088	-301.028	
		100.000			-7.852
13		-----			
	1	.000			-14.185
		.000	.992	-77.035	
		100.080	1.405	42.916	
		100.080			-14.202
14		-----			
	1	.000			-20.432
		.000	-.201	10.402	
		48.779	.000	5.503	
		100.080	.211	10.922	
		100.080			-20.449
15		-----			
	1	.000			-24.787
		.000	-.051	-.762	
		12.480	.000	-1.083	
		100.080	.361	14.719	
		100.080			-24.803
16		-----			
	1	.000			-27.345
		.000	-.176	5.696	
		42.733	.000	1.935	
		100.080	.236	8.708	
		100.080			-27.361
17		-----			
	1	.000			-28.092
		.000	-.181	8.708	
		43.895	.000	4.740	
		100.080	.231	11.240	
		100.080			-28.109
18		-----			
	1	.000			-27.414
		.000	-.289	11.240	
		70.188	.000	1.096	
		100.080	.123	2.936	
		100.080			-27.430
19		-----			
	1	.000			-27.431
		.000	-.130	2.936	
		31.511	.000	.891	
		100.080	.282	10.573	
		100.080			-27.414
20		-----			
	1	.000			-26.609
		.000	-.236	10.573	
		57.258	.000	3.822	
		100.080	.176	7.598	
		100.080			-26.593
21		-----			
	1	.000			-24.236
		.000	-.253	7.598	
		61.457	.000	-.179	
		100.080	.159	2.892	
		100.080			-24.219
22		-----			
	1	.000			-19.948
		.000	-.333	14.258	
		80.855	.000	.796	
		100.080	.079	1.557	
		100.080			-19.931

23		-----			
	1	.000			-13.804
		.000	-.654	22.165	
		100.080	-.242	-22.688	
		100.080			-13.788
24		-----			
	1	.000			-4.930
		.000	.212	1.482	
		100.080	.625	43.358	
		100.080			-4.913
25		-----			
	1	.000			-13.025
		.000	.532	160.912	
		11.319	.000	163.923	
		120.000	-5.108	-113.651	
		120.000			-13.025
26		-----			
	1	.000			-6.058
		.000	-.161	-.829	
		124.000	-.161	-20.788	
		124.000			-6.058
27		-----			
	1	.000			-5.242
		.000	-.158	11.386	
		128.000	-.158	-8.861	
		128.000			-5.242
28		-----			
	1	.000			-2.788
		.000	-.088	6.123	
		132.000	-.088	-5.513	
		132.000			-2.788
29		-----			
	1	.000			-.628
		.000	.000	.000	
		136.000	.000	.000	
		136.000			-.628
30		-----			
	1	.000			1.490
		.000	.000	.000	
		140.000	.000	.000	
		140.000			1.490
31		-----			
	1	.000			2.445
		.000	.000	.000	
		144.000	.000	.000	
		144.000			2.445
32		-----			
	1	.000			-.669
		.000	.000	.000	
		140.000	.000	.000	
		140.000			-.669
33		-----			
	1	.000			-2.892
		.000	.000	.000	
		136.000	.000	.000	
		136.000			-2.892
34		-----			
	1	.000			-5.132
		.000	.133	-9.316	
		132.000	.133	8.298	
		132.000			-5.132
35		-----			
	1	.000			-7.030
		.000	.197	-11.384	
		128.000	.197	13.826	
		128.000			-7.030
36		-----			
	1	.000			-10.938
		.000	.714	-60.429	
		124.000	.714	28.145	
		124.000			-10.938
37		-----			
	1	.000			-8.527
		.000	-3.191	297.844	
		120.000	-3.191	-85.079	
		120.000			-8.527
38		-----			
	1	.000			14.587
		.000	.407	-36.616	
		156.205	.407	26.882	
		156.205			14.587
39		-----			
	1	.000			9.618

		.000	-.117	11.726	
		159.298	-.117	-6.969	
		159.298			9.618
40	1	.000			6.778
		.000	-.017	2.823	
		162.432	-.017	.000	
		162.432			6.778
41	1	.000			4.062
		.000	-.025	3.511	
		165.602	-.025	-.698	
		165.602			4.062
42	1	.000			1.261
		.000	.000	.000	
		168.808	.000	.000	
		168.808			1.261
43	1	.000			-1.158
		.000	.000	.000	
		172.047	.000	.000	
		172.047			-1.158
44	1	.000			1.419
		.000	.000	.000	
		172.047	.000	.000	
		172.047			1.419
45	1	.000			4.005
		.000	.000	.000	
		168.808	.000	.000	
		168.808			4.005
46	1	.000			6.855
		.000	.019	.000	
		165.602	.019	3.068	
		165.602			6.855
47	1	.000			9.590
		.000	.064	-3.553	
		162.432	.064	6.783	
		162.432			9.590
48	1	.000			12.982
		.000	-.040	2.326	
		159.298	-.040	-3.976	
		159.298			12.982
49	1	.000			12.081
		.000	.509	-37.826	
		156.205	.509	41.721	
		156.205			12.081
50	1	.000			-10.485
		.000	6.845	-762.025	
		282.000	.979	341.131	
		282.000			-10.485
51	1	.000			-12.615
		.000	4.661	-715.502	
		282.000	4.661	598.871	
		282.000			-12.615
52	1	.000			-10.485
		.000	6.970	-803.467	
		6.000	6.845	-762.025	
		6.000			-10.485
53	1	.000			-12.615
		.000	4.661	-743.468	
		6.000	4.661	-715.502	
		6.000			-12.615

STRUCTURAL ANALYSIS PROGRAMS

VERSION 5.41

Copyright (C) 1978-1994
 EDWARD L. WILSON
 All rights reserved

Input:

Wood Truss at Area B
 c USCERL
 c Apr. 27 1998
 c Load Combination=D.L+L.L+P.L
 c Section I-A
 system
 L=1

joints
 1 x=0 y=0 z=0
 9 x=600 y=0 g=1,9
 10 x=0 y=79 z=0
 18 x=600 y=79 g=10,18
 19 x=0 y=-75 z=0
 21 x=0 y=-192 z=0
 22 x=600 y=-75 z=0
 24 x=600 y=-192 z=0
 20 x=0 y=-186 z=0
 23 x=600 y=-186 z=0
 25 x=52.75 y=0 z=0
 26 x=547.25 y=0 z=0

restraints
 21 r=1,1,1,1,1,1
 24 r=1,1,1,1,1,1

frame
 nm=6 nl=3
 1 a=36.26 i=158.78 e=1770
 2 a=28.13 i=296.63 e=1770
 3 a=56.26 i=593.26 e=1770
 4 a=13.75 i=34.66 e=1770
 5 a=120 i=1440 e=1770
 6 a=60 i=720 e=1770
 1 wg=0, -.02425, 0
 2 wg=.0467, 0, 0
 3 wg=.02, 0, 0
 1 1 25 m=1 lr=0,0,0,0,0,0 nsl=1
 2 2 3 m=1 lr=0,0,0,0,0,0 nsl=1
 g=5,1,1,1
 8 26 9 m=1 lr=0,0,0,0,0,0 nsl=1
 9 10 11 m=1 lr=0,0,0,0,0,0 nsl=1
 g=7,1,1,1
 17 1 10 m=2 lr=0,0,0,0,0,0
 18 2 11 m=2 lr=0,0,0,0,0,0
 19 3 12 m=4 lr=1,1,0,0,0,0
 20 4 13 m=4 lr=1,1,0,0,0,0
 21 5 14 m=4 lr=1,1,0,0,0,0
 22 6 15 m=4 lr=1,1,0,0,0,0
 23 7 16 m=4 lr=1,1,0,0,0,0
 24 8 17 m=2 lr=0,0,0,0,0,0
 25 9 18 m=2 lr=0,0,0,0,0,0
 26 10 2 m=3 lr=1,1,0,0,0,0
 27 11 3 m=3 lr=0,1,0,0,0,0
 28 12 4 m=1 lr=1,1,0,0,0,0
 29 13 5 m=4 lr=1,1,0,0,0,0
 30 5 15 m=4 lr=1,1,0,0,0,0
 31 6 16 m=1 lr=1,1,0,0,0,0
 32 7 17 m=1 lr=1,0,0,0,0,0
 33 8 18 m=3 lr=1,1,0,0,0,0
 34 19 2 m=3 lr=0,0,0,0,0,0
 35 22 8 m=3 lr=0,0,0,0,0,0
 36 19 1 m=5 lr=0,0,0,0,0,0
 37 22 9 m=5 lr=0,0,0,0,0,0
 38 20 19 m=5 lr=0,0,0,0,0,0
 39 23 22 m=5 lr=0,0,0,0,0,0
 40 21 20 m=6 lr=0,0,0,0,0,0
 41 24 23 m=6 lr=0,0,0,0,0,0
 42 25 2 m=1 lr=0,0,0,0,0,0 nsl=1
 43 8 26 m=1 lr=0,0,0,0,0,0 nsl=1

loads

2 8 1 L=1 f=0, -1, 0

Output:

CSI / SAP90 - - FINITE ELEMENT ANALYSIS
 OF STRUCTURES PAGE 1

PROGRAM:SAP90/FILE:trussb.F3F
 Wood Truss at Area B

FRAME ELEMENT FORCES

1-3 PLANE	ELEM ID	LOAD COND	1-2 PLANE			AXIAL FORCE
			AXIAL	SHEAR	MOMENT	

1	1	1	.000	.725	-3.293	3.282
			.000	.000	7.543	
			29.895	.000	1.209	
			52.750	-.554		
			52.750			3.282

2	1	1	.000	.911	-10.067	4.868
			.000	.000	7.049	
			37.573	.000	-9.935	
			75.000	-.908		
			75.000			4.868

3	1	1	.000	.931	-9.935	15.735
			.000	.000	7.939	
			38.395	.000	-8.308	
			75.000	-.888		
			75.000			15.735

4	1	1	.000	.976	-8.308	22.371
			.000	.000	11.340	
			40.255	.000	-3.298	
			75.000	-.843		
			75.000			22.371

5	1	1	.000	.837	-3.298	22.382
			.000	.000	11.153	
			34.524	.000	-8.711	
			75.000	-.982		
			75.000			22.382

6	1	1	.000	.915	-8.711	15.701
			.000	.000	8.562	
			37.744	.000	-8.268	
			75.000	-.903		
			75.000			15.701

7	1	1	.000	.852	-8.268	4.952
			.000	.000	6.693	
			35.127	.000	-12.584	
			75.000	-.967		
			75.000			4.952

8	1	1	.000	.559	1.075	3.270
			.000	.000	7.517	
			23.050	.000	-3.179	
			52.750	-.720		
			52.750			3.270

9	1	1	.000	1.110	-17.928	-8.382
			.000	.000	7.487	
			45.784	.000	-2.862	
			75.000	-.708		
			75.000			-8.382

10	1	1	.000	1.090	-19.248	-19.689
			.000	.000	5.256	
			44.955	.000	-5.690	
			75.000	-.729		
			75.000			-19.689

11	1	1	.000	.856	-5.690	-26.325
			.000	.000	9.405	
			35.283	.000	-9.722	
			75.000	-.963		
			75.000			-26.325

12						

	1	.000			-28.389		108.931	-.024	.000		
		.000	.988	-9.722			108.931			15.759	
		40.748	.000	10.411							
		75.000	-.831	-3.814							
		75.000			-28.389						
13		-----									
	1	.000			-28.389		1	.000			9.638
		.000	.826	-3.814				.000	.000		
		34.069	.000	10.259			108.931	.000	.000		
		75.000	-.993	-10.055			108.931				
		75.000			-28.389						
14		-----									
	1	.000			-26.336		1	.000			2.998
		.000	.987	-10.055				.000	.000		
		40.688	.000	10.018			108.931	.000	.000		
		75.000	-.832	-4.257			108.931				
		75.000			-26.336						
15		-----									
	1	.000			-19.655		1	.000			9.705
		.000	.687	-4.257				.000	.000		
		28.335	.000	5.478			108.931	.000	.000		
		75.000	-1.132	-20.927			108.931				
		75.000			-19.655						
16		-----									
	1	.000			-8.415		1	.000			15.605
		.000	.728	-3.970				.007	.000		
		30.034	.000	6.967			108.931	.007	.715		
		75.000	-1.090	-17.549			108.931				
		75.000			-8.415						
17		-----									
	1	.000			-9.357		1	.000			11.430
		.000	-.552	25.718				.000	.000		
		79.000	-.552	-17.928			108.931	.000	.000		
		79.000			-9.357		108.931				
18		-----									
	1	.000			-13.211		1	.000			15.605
		.000	-.440	20.933				.007	.000		
		79.000	-.440	-13.806			108.931	.007	.715		
		79.000			-13.211						
19		-----									
	1	.000			-8.574		1	.000			11.430
		.000	.000	.000				.000	.000		
		79.000	.000	.000			108.931	.000	.000		
		79.000			-8.574		108.931				
20		-----									
	1	.000			-4.126		1	.000			11.430
		.000	.000	.000				.000	.000		
		79.000	.000	.000			108.931	.000	.000		
		79.000			-4.126						
21		-----									
	1	.000			-1.657		1	.000			15.605
		.000	.000	.000				.007	.000		
		79.000	.000	.000			108.931	.007	.715		
		79.000			-1.657						
22		-----									
	1	.000			-4.141		1	.000			15.605
		.000	.000	.000				.007	.000		
		79.000	.000	.000			108.931	.007	.715		
		79.000			-4.141						
23		-----									
	1	.000			-8.557		1	.000			11.430
		.000	.000	.000				.000	.000		
		79.000	.000	.000			108.931	.000	.000		
		79.000			-8.557						
24		-----									
	1	.000			-13.173		1	.000			11.430
		.000	.491	-22.516				.000	.000		
		79.000	.491	16.242			108.931	.000	.000		
		79.000			-13.173						
25		-----									
	1	.000			-9.380		1	.000			15.605
		.000	.546	-25.555				.000	.000		
		79.000	.546	17.549			108.931	.000	.000		
		79.000			-9.380						
26		-----									
	1	.000			11.372		1	.000			2.998
		.000	.000	.000				.000	.000		
		108.931	.000	.000			108.931	.000	.000		
		108.931			11.372						
27		-----									
	1	.000			15.759		1	.000			9.705
		.000	-.024	2.580				.000	.000		
							22.250	-1.094	-17.125		
							22.250			3.282	
	1	.000			3.270		1	.000			2.981
		.000	1.099	-17.364				.000	.000		
		22.250	.559	1.075			22.250				
		22.250			15.759						

STRUCTURAL ANALYSIS PROGRAMS

VERSION 5.41

Copyright (C) 1978-1994
 EDWARD L. WILSON
 All rights reserved

Input:

Wood Truss at Area B
 c USCERL
 c Apr. 27 1998
 c Load Combination=D.L+W.L+P.L
 c Section I-A

system
 L=1

joints

1 x=0 y=0 z=0
 9 x=600 y=0 g=1,9
 10 x=0 y=79 z=0
 18 x=600 y=79 g=10,18
 19 x=0 y=-75 z=0
 21 x=0 y=-192 z=0
 22 x=600 y=-75 z=0
 24 x=600 y=-192 z=0
 20 x=0 y=-186 z=0
 23 x=600 y=-186 z=0
 25 x=52.75 y=0 z=0
 26 x=547.25 y=0 z=0

restraints

21 r=1,1,1,1,1,1
 24 r=1,1,1,1,1,1

frame

mm=6 nl=3
 1 a=36.26 i=158.78 e=1770
 2 a=28.13 i=296.63 e=1770
 3 a=56.26 i=593.26 e=1770
 4 a=13.75 i=34.66 e=1770
 5 a=120 i=1440 e=1770
 6 a=60 i=720 e=1770
 1 wg=0,0.0051,0
 2 wg=.0467,0,0
 3 wg=.02,0,0
 1 1 25 m=1 lr=0,0,0,0,0,0 nsl=1
 2 2 3 m=1 lr=0,0,0,0,0,0 nsl=1
 g=5,1,1,1
 8 26 9 m=1 lr=0,0,0,0,0,0 nsl=1
 9 10 11 m=1 lr=0,0,0,0,0,0 nsl=1
 g=7,1,1,1
 17 1 10 m=2 lr=0,0,0,0,0,0 nsl=2
 18 2 11 m=2 lr=0,0,0,0,0,0
 19 3 12 m=4 lr=1,1,0,0,0,0
 20 4 13 m=4 lr=1,1,0,0,0,0
 21 5 14 m=4 lr=1,1,0,0,0,0
 22 6 15 m=4 lr=1,1,0,0,0,0
 23 7 16 m=4 lr=1,1,0,0,0,0
 24 8 17 m=2 lr=0,0,0,0,0,0
 25 9 18 m=2 lr=0,0,0,0,0,0
 26 10 2 m=3 lr=1,1,0,0,0,0
 27 11 3 m=3 lr=0,1,0,0,0,0
 28 12 4 m=1 lr=1,1,0,0,0,0
 29 13 5 m=4 lr=1,1,0,0,0,0
 30 5 15 m=4 lr=1,1,0,0,0,0
 31 6 16 m=1 lr=1,1,0,0,0,0
 32 7 17 m=1 lr=1,0,0,0,0,0
 33 8 18 m=3 lr=1,1,0,0,0,0
 34 19 2 m=3 lr=0,0,0,0,0,0
 35 22 8 m=3 lr=0,0,0,0,0,0
 36 19 1 m=5 lr=0,0,0,0,0,0 nsl=3
 37 22 9 m=5 lr=0,0,0,0,0,0
 38 20 19 m=5 lr=0,0,0,0,0,0 nsl=3
 39 23 22 m=5 lr=0,0,0,0,0,0
 40 21 20 m=6 lr=0,0,0,0,0,0 nsl=3
 41 24 23 m=6 lr=0,0,0,0,0,0
 42 25 2 m=1 lr=0,0,0,0,0,0 nsl=1
 43 8 26 m=1 lr=0,0,0,0,0,0 nsl=1

loads

2 8 1 L=1 f=0,-1,0

Output:

CSI / SAP90 - - FINITE ELEMENT ANALYSIS
 OF STRUCTURES PAGE 1

PROGRAM:SAP90/FILE:trussb.F3F
 Wood Truss at Area B

FRAME ELEMENT FORCES

1-3 PLANE	DIST	1-2 PLANE		AXIAL
ID COND	AXIAL	SHEAR	MOMENT	FORCE
SHEAR	MOMENT	TORQ		
1 -----				
1	.000			-4.762
	.000	-.050	-2.322	
	9.785	.000	-2.566	
	52.750	.219	2.141	
	52.750			-4.762
2 -----				
1	.000			1.394
	.000	-.173	1.701	
	33.883	.000	-1.226	
	75.000	.210	3.085	
	75.000			1.394
3 -----				
1	.000			.766
	.000	-.193	3.085	
	37.852	.000	-.569	
	75.000	.189	2.950	
	75.000			.766
4 -----				
1	.000			-.138
	.000	-.194	2.950	
	38.085	.000	-.748	
	75.000	.188	2.727	
	75.000			-.138
5 -----				
1	.000			-2.580
	.000	-.205	2.727	
	40.141	.000	-1.382	
	75.000	.178	1.717	
	75.000			-2.580
6 -----				
1	.000			-4.168
	.000	-.183	1.717	
	35.939	.000	-1.577	
	75.000	.199	2.314	
	75.000			-4.168
7 -----				
1	.000			-5.902
	.000	-.205	2.314	
	40.200	.000	-1.807	
	75.000	.177	1.281	
	75.000			-5.902
8 -----				
1	.000			1.645
	.000	.094	-3.264	
	52.750	.363	8.813	
	52.750			1.645
9 -----				
1	.000			-4.460
	.000	.041	-8.933	
	75.000	.424	8.502	
	75.000			-4.460
10 -----				
1	.000			-3.824
	.000	-.219	4.408	
	42.868	.000	-.278	
	75.000	.164	2.354	
	75.000			-3.824
11 -----				
1	.000			-2.920
	.000	-.185	2.354	
	36.336	.000	-1.012	
	75.000	.197	2.800	
	75.000			-2.920
12 -----				
1	.000			-1.802
	.000	-.193	2.800	

		37.881	.000	-.859	
		75.000	.189	2.654	
		75.000			-1.802
13		-----			
	1	.000			-1.802
		.000	-.201	2.654	
		39.422	.000	-1.309	
		75.000	.181	1.919	
		75.000			-1.802
14		-----			
	1	.000			-.478
		.000	-.180	1.919	
		35.306	.000	-1.259	
		75.000	.202	2.759	
		75.000			-.478
15		-----			
	1	.000			1.110
		.000	-.228	2.759	
		44.730	.000	-2.343	
		75.000	.154	-.007	
		75.000			1.110
16		-----			
	1	.000			2.904
		.000	-.175	1.092	
		34.271	.000	-1.903	
		75.000	.208	2.327	
		75.000			2.904
17		-----			
	1	.000			-3.087
		.000	2.120	-30.711	
		45.403	.000	17.423	
		79.000	-1.569	-8.933	
		79.000			-3.087
18		-----			
	1	.000			1.346
		.000	.008	-1.530	
		79.000	.008	-.869	
		79.000			1.346
19		-----			
	1	.000			1.301
		.000	.000	.000	
		79.000	.000	.000	
		79.000			1.301
20		-----			
	1	.000			1.568
		.000	.000	.000	
		79.000	.000	.000	
		79.000			1.568
21		-----			
	1	.000			.390
		.000	.000	.000	
		79.000	.000	.000	
		79.000			.390
22		-----			
	1	.000			-1.033
		.000	.000	.000	
		79.000	.000	.000	
		79.000			-1.033
23		-----			
	1	.000			-1.242
		.000	.000	.000	
		79.000	.000	.000	
		79.000			-1.242
24		-----			
	1	.000			-1.508
		.000	.060	-2.856	
		79.000	.060	1.886	
		79.000			-1.508
25		-----			
	1	.000			3.248
		.000	-.018	-.933	
		79.000	-.018	-2.327	
		79.000			3.248
26		-----			
	1	.000			4.199
		.000	.000	.000	
		108.931	.000	.000	
		108.931			4.199
27		-----			
	1	.000			-.943
		.000	-.030	3.226	
		108.931	-.030	.000	
		108.931			-.943
28		-----			
	1	.000			-1.313
		.000	.000	.000	
		108.931	.000	.000	
		108.931			-1.313
29		-----			
	1	.000			-1.624
		.000	.000	.000	
		108.931	.000	.000	
		108.931			-1.624
30		-----			
	1	.000			1.923
		.000	.000	.000	
		108.931	.000	.000	
		108.931			1.923
31		-----			
	1	.000			2.306
		.000	.000	.000	
		108.931	.000	.000	
		108.931			2.306
32		-----			
	1	.000			2.527
		.000	-.007	.000	
		108.931	-.007	-.787	
		108.931			2.527
33		-----			
	1	.000			-4.192
		.000	.000	.000	
		108.931	.000	.000	
		108.931			-4.192
34		-----			
	1	.000			5.070
		.000	-.442	38.754	
		106.066	-.442	-8.108	
		106.066			5.070
35		-----			
	1	.000			-7.123
		.000	-.446	39.076	
		106.066	-.446	-8.239	
		106.066			-7.123
36		-----			
	1	.000			-3.037
		.000	-1.141	108.815	
		75.000	-2.641	-33.033	
		75.000			-3.037
37		-----			
	1	.000			3.611
		.000	-1.663	114.963	
		75.000	-1.663	-9.746	
		75.000			3.611
38		-----			
	1	.000			.860
		.000	4.351	-212.191	
		111.000	2.131	147.569	
		111.000			.860
39		-----			
	1	.000			-1.740
		.000	3.058	-185.423	
		111.000	3.058	154.039	
		111.000			-1.740
40		-----			
	1	.000			.860
		.000	4.471	-238.658	
		6.000	4.351	-212.191	
		6.000			.860
41		-----			
	1	.000			-1.740
		.000	3.058	-203.772	
		6.000	3.058	-185.423	
		6.000			-1.740
42		-----			
	1	.000			-4.762
		.000	.219	2.141	
		22.250	.333	8.279	
		22.250			-4.762
43		-----			
	1	.000			1.645
		.000	-.019	-4.102	
		3.735	.000	-4.138	
		22.250	.094	-3.264	
		22.250			1.645

STRUCTURAL ANALYSIS PROGRAMS

VERSION 5.41

Copyright (C) 1978-1994
 EDWARD L. WILSON
 All rights reserved

Input:

Wood Truss at Area D
 c Dexter Yoon
 c Apr. 27 1998
 c Load Combination=D.L+L.L+P.L
 system
 L=1

joints

1 x=0 y=0 z=0
 11 x=600 y=0 g=1,11
 12 x=0 y=72 z=0
 22 x=600 y=72 g=12,22
 23 x=42.2 y=0 z=0
 24 x=0 y=-42.2 z=0
 25 x=0 y=-186 z=0
 26 x=0 y=-192 z=0
 27 x=557.8 y=0 z=0
 28 x=600 y=-42.2 z=0
 29 x=600 y=-186 z=0
 30 x=600 y=-192 z=0

restraints

26 r=1,1,1,1,1,1
 30 r=1,1,1,1,1,1

frame

nm=7 nl=3
 1 a=36.26 i=158.78 e=1770
 2 a=28.13 i=296.63 e=1770
 3 a=13.75 i=34.66 e=1770
 4 a=56.26 i=593.26 e=1770
 5 a=27.50 i=69.32 e=1770
 6 a=120 i=1440 e=1770
 7 a=60 i=720 e=1770
 1 wj=0, -.02425,0
 2 wj=-.0467,0,0
 3 wj=-.02,0,0
 1 1 23 m=1 lr=0,0,0,0,0,0 nsl=1
 2 2 3 m=1 lr=0,0,0,0,0,0 nsl=1
 g=7,1,1,1
 10 27 11 m=1 lr=0,0,0,0,0,0 nsl=1
 11 12 13 m=1 lr=0,0,0,0,0,0 nsl=1
 g=9,1,1,1
 21 1 12 m=2 lr=0,0,0,0,0,0
 22 2 13 m=2 lr=0,0,0,0,0,0
 23 3 14 m=2 lr=0,1,0,0,0,0
 24 4 15 m=3 lr=1,1,0,0,0,0
 25 5 16 m=3 lr=1,1,0,0,0,0
 26 6 17 m=3 lr=1,1,0,0,0,0
 27 7 18 m=3 lr=1,1,0,0,0,0
 28 8 19 m=3 lr=1,1,0,0,0,0
 29 9 20 m=2 lr=0,1,0,0,0,0
 30 10 21 m=2 lr=0,0,0,0,0,0
 31 11 22 m=2 lr=0,0,0,0,0,0
 32 12 2 m=4 lr=0,0,0,0,0,0
 33 13 3 m=4 lr=0,0,0,0,0,0
 34 14 4 m=1 lr=1,1,0,0,0,0
 35 15 5 m=5 lr=1,1,0,0,0,0
 36 16 6 m=3 lr=1,1,0,0,0,0
 37 6 18 m=3 lr=1,1,0,0,0,0
 38 7 19 m=5 lr=1,1,0,0,0,0
 39 8 20 m=1 lr=1,1,0,0,0,0
 40 9 21 m=2 lr=0,0,0,0,0,0
 41 10 22 m=4 lr=0,0,0,0,0,0
 42 23 2 m=1 lr=0,0,0,0,0,0 nsl=1
 43 24 23 m=4 lr=0,0,0,0,0,0
 44 24 1 m=6 lr=0,0,0,0,0,0
 45 25 24 m=6 lr=0,0,0,0,0,0
 46 26 25 m=7 lr=0,0,0,0,0,0
 47 10 27 m=1 lr=0,0,0,0,0,0 nsl=1
 48 28 27 m=4 lr=0,0,0,0,0,0
 49 28 11 m=6 lr=0,0,0,0,0,0
 50 29 28 m=6 lr=0,0,0,0,0,0

51 30 29 m=7 lr=0,0,0,0,0,0

loads

2 10 1 L=1 f=0,-1,0

Output:

CSI / SAP90 - - FINITE ELEMENT ANALYSIS
 OF STRUCTURES
 PROGRAM:SAP90/FILE:trussd.F3F

FRAME ELEMENT FORCES

ELT 1-3 PLANE	LOAD ID COND	DIST AXIAL ENDD	1-2 PLANE		AXIAL FORCE
			SHEAR	MOMENT	
			TORQ		
1 -----					
1	1	.000			5.125
		.000			
		42.200	-1.501	12.331	
		42.200		-29.410	5.125
2 -----					
1	1	.000			7.356
		.000	.825	-5.701	
		34.030	.000	8.340	
		60.000	-.630	.162	
		60.000			7.356
3 -----					
1	1	.000			18.735
		.000	.842	-9.746	
		34.731	.000	4.880	
		60.000	-.613	-2.862	
		60.000			18.735
4 -----					
1	1	.000			26.758
		.000	.735	-2.862	
		30.289	.000	8.262	
		60.000	-.720	-2.441	
		60.000			26.758
5 -----					
1	1	.000			31.654
		.000	.800	-2.441	
		32.989	.000	10.754	
		60.000	-.655	1.908	
		60.000			31.654
6 -----					
1	1	.000			31.652
		.000	.658	1.908	
		27.131	.000	10.833	
		60.000	-.797	-2.267	
		60.000			31.652
7 -----					
1	1	.000			26.785
		.000	.707	-2.267	
		29.143	.000	8.031	
		60.000	-.748	-3.514	
		60.000			26.785
8 -----					
1	1	.000			18.658
		.000	.665	-3.514	
		27.442	.000	5.617	
		60.000	-.790	-7.236	
		60.000			18.658
9 -----					
1	1	.000			7.554
		.000	.420	5.971	
		17.338	.000	9.616	
		60.000	-1.035	-12.453	
		60.000			7.554
10 -----					
1	1	.000			5.084
		.000	1.506	-29.534	
		42.200	.483	12.427	
		42.200			5.084
11 -----					
1	1	.000			-9.340
		.000	1.249	-22.552	
		51.521	.000	9.633	
		60.000	-.206	8.761	
		60.000			-9.340
12 -----					
1	1	.000			-21.292

		.000	.893	-14.088	1	.000			-3.336
		36.823	.000	2.353		.000	.000	.000	
		60.000	-.562	-4.161		72.000	.000	.000	
		60.000		-21.292		72.000			-3.336
13	1	.000		-29.436	28	1	.000		-7.339
		.000	.762	-4.161		.000	.000	.000	
		31.425	.000	7.813		72.000	.000	.000	
		60.000	-.693	-2.087		72.000			-7.339
		60.000		-29.436	29	1	.000		-10.860
14	1	.000		-34.332		.000	.170	-12.214	
		.000	.712	-2.087		72.000	.170	.000	
		29.363	.000	8.366		72.000			-10.860
		60.000	-.743	-3.015	30	1	.000		-14.357
		60.000		-34.332		.000	.806	-34.601	
15	1	.000		-35.849		72.000	.806	23.406	
		.000	.791	-3.015		72.000			-14.357
		32.617	.000	9.885	31	1	.000		-11.426
		60.000	-.664	.793		.000	.178	-7.830	
		60.000		-35.849		72.000	.178	4.996	
16	1	.000		-35.849	32	1	.000		13.638
		.000	.667	.793		.000	-.539	16.785	
		27.521	.000	9.976		93.723	-.539	-33.719	
		60.000	-.788	-2.814		93.723			13.638
		60.000		-35.849	33	1	.000		17.520
17	1	.000		-34.330		.000	-.055	3.988	
		.000	.725	-2.814		93.723	-.055	-1.182	
		29.887	.000	8.016		93.723			17.520
		60.000	-.730	-2.979	34	1	.000		12.532
		60.000		-34.330		.000	.000	.000	
18	1	.000		-29.463		93.723	.000	.000	
		.000	.769	-2.979		93.723			12.532
		31.727	.000	9.226	35	1	.000		7.648
		60.000	-.686	-.466		.000	.000	.000	
		60.000		-29.463		93.723	.000	.000	7.648
19	1	.000		-21.166	36	1	.000		2.370
		.000	.421	-.466		.000	.000	.000	
		17.374	.000	3.194		93.723	.000	.000	2.370
		60.000	-1.034	-18.836	37	1	.000		2.374
		60.000		-21.166		.000	.000	.000	
20	1	.000		-9.427		93.723	.000	.000	2.374
		.000	.254	6.611	38	1	.000		7.602
		10.458	.000	7.938		.000	.000	.000	
		60.000	-1.201	-21.822		93.723	.000	.000	7.602
		60.000		-9.427	39	1	.000		12.696
21	1	.000		-11.382		.000	.000	.000	
		.000	-.195	8.266		93.723	.000	.000	12.696
		72.000	-.195	-5.767	40	1	.000		17.040
		72.000		-11.382		.000	.032	-.992	
22	1	.000		-14.522		93.723	.032	2.042	
		.000	-.693	31.064	41	1	.000		13.775
		72.000	-.693	-18.861		.000	.559	-35.606	
		72.000		-14.522		93.723	.559	16.826	13.775
23	1	.000		-10.952	42	1	.000		-2.483
		.000	-.121	8.727		.000	6.647	-55.387	
		72.000	-.121	.000		17.800	6.215	59.082	-2.483
		72.000		-10.952	43	1	.000		-11.141
24	1	.000		-7.280		.000	.381	-48.742	
		.000	.000	.000		59.680	.381	-25.976	
		72.000	.000	.000					
		72.000		-3.355					
25	1	.000		-3.355					
		.000	.000	.000					
		72.000	.000	.000					
		72.000		-3.355					
26	1	.000		-1.331					
		.000	.000	.000					
		72.000	.000	.000					
		72.000		-1.331					
27	1	.000		-1.331					

		59.680		-11.141
44	-----			
	1	.000		-10.904
		.000	4.930	-187.457
		42.200	4.930	20.596
		42.200		-10.904
45	-----			
	1	.000		-19.052
		.000	-2.678	148.878
		143.800	-2.678	-236.199
		143.800		-19.052
46	-----			
	1	.000		-19.052
		.000	-2.678	164.946
		6.000	-2.678	148.878
		6.000		-19.052
47	-----			
	1	.000		-2.500
		.000	-6.168	57.754
		17.800	-6.599	-55.870
		17.800		-2.500
48	-----			
	1	.000		-11.094
		.000	-.369	48.350
		59.680	-.369	26.336
		59.680		-11.094
49	-----			
	1	.000		-10.943
		.000	-4.906	186.762
		42.200	-4.906	-20.257
		42.200		-10.943
50	-----			
	1	.000		-19.048
		.000	2.678	-149.965
		143.800	2.678	235.112
		143.800		-19.048
51	-----			
	1	.000		-19.048
		.000	2.678	-166.032
		6.000	2.678	-149.965
		6.000		-19.048

STRUCTURAL ANALYSIS PROGRAMS

VERSION 5.41
 Copyright (C) 1978-1994
 EDWARD L. WILSON
 All rights reserved

Input:

Wood Truss at Area D
 c Dexter Yoon
 c Apr. 27 1998
 c Load Combination=D.L+W.L+P.L
 system
 L=1

joints
 1 x=0 y=0 z=0
 11 x=600 y=0 g=1,11
 12 x=0 y=72 z=0
 22 x=600 y=72 g=12,22
 23 x=42.2 y=0 z=0
 24 x=0 y=-42.2 z=0
 25 x=0 y=-186 z=0
 26 x=0 y=-192 z=0
 27 x=557.8 y=0 z=0
 28 x=600 y=-42.2 z=0
 29 x=600 y=-186 z=0
 30 x=600 y=-192 z=0

restraints
 26 r=1,1,1,1,1,1
 30 r=1,1,1,1,1,1

frame
 nm=7 nl=3
 1 a=36.26 i=158.78 e=1770
 2 a=28.13 i=296.63 e=1770
 3 a=13.75 i=34.66 e=1770
 4 a=56.26 i=593.26 e=1770
 5 a=27.50 i=69.32 e=1770
 6 a=120 i=1440 e=1770
 7 a=60 i=720 e=1770
 1 wg=0,0,0051,0
 2 wg=-.0467,0,0
 3 wg=-.02,0,0
 1 1 23 m=1 lr=0,0,0,0,0,0 nsl=1
 2 2 3 m=1 lr=0,0,0,0,0,0 nsl=1
 g=7,1,1,1
 10 27 11 m=1 lr=0,0,0,0,0,0 nsl=1
 11 12 13 m=1 lr=0,0,0,0,0,0 nsl=1
 g=9,1,1,1
 21 1 12 m=2 lr=0,0,0,0,0,0
 22 2 13 m=2 lr=0,0,0,0,0,0
 23 3 14 m=2 lr=0,1,0,0,0,0
 24 4 15 m=3 lr=1,1,0,0,0,0
 25 5 16 m=3 lr=1,1,0,0,0,0
 26 6 17 m=3 lr=1,1,0,0,0,0
 27 7 18 m=3 lr=1,1,0,0,0,0
 28 8 19 m=3 lr=1,1,0,0,0,0
 29 9 20 m=2 lr=0,1,0,0,0,0
 30 10 21 m=2 lr=0,0,0,0,0,0
 31 11 22 m=2 lr=0,0,0,0,0,0 nsl=2
 32 12 2 m=4 lr=0,0,0,0,0,0
 33 13 3 m=4 lr=0,0,0,0,0,0
 34 14 4 m=1 lr=1,1,0,0,0,0
 35 15 5 m=5 lr=1,1,0,0,0,0
 36 16 6 m=3 lr=1,1,0,0,0,0
 37 6 18 m=3 lr=1,1,0,0,0,0
 38 7 19 m=5 lr=1,1,0,0,0,0
 39 8 20 m=1 lr=1,1,0,0,0,0
 40 9 21 m=2 lr=0,0,0,0,0,0
 41 10 22 m=4 lr=0,0,0,0,0,0
 42 23 2 m=1 lr=0,0,0,0,0,0 nsl=1
 43 24 23 m=4 lr=0,0,0,0,0,0
 44 24 1 m=6 lr=0,0,0,0,0,0
 45 25 24 m=6 lr=0,0,0,0,0,0
 46 26 25 m=7 lr=0,0,0,0,0,0
 47 10 27 m=1 lr=0,0,0,0,0,0 nsl=1
 48 28 27 m=4 lr=0,0,0,0,0,0
 49 28 11 m=6 lr=0,0,0,0,0,0 nsl=3
 50 29 28 m=6 lr=0,0,0,0,0,0 nsl=3
 51 30 29 m=7 lr=0,0,0,0,0,0 nsl=3

loads
 2 10 1 L=1 f=0,-1,0

Output

CSI / SAP90 - - FINITE ELEMENT ANALYSIS
 OF STRUCTURES PAGE 1

PROGRAM:SAP90/FILE:trussd.F3F

FRAME ELEMENT FORCES		1-2 PLANE			AXIAL	
ELT	LOAD	DIST	AXIAL	SHEAR	MOMENT	FORCE
1-3 PLANE	ID	COND	ENDDI	TORQ		
SHEAR	MOMENT					
1	1	.000	.000	-1.089	16.793	3.430
			42.200	-.874	-24.632	
			42.200			3.430
2	1	.000	.000	-.286	7.495	-5.018
			56.124	.000	-.537	
			60.000	.020	-.498	
			60.000			-5.018
3	1	.000	.000	-.121	-.156	-3.006
			23.698	.000	-1.588	
			60.000	.185	1.772	
			60.000			-3.006
4	1	.000	.000	-.159	1.772	-1.348
			31.265	.000	-.720	
			60.000	.147	1.385	
			60.000			-1.348
5	1	.000	.000	-.138	1.385	.015
			27.118	.000	-.490	
			60.000	.168	2.267	
			60.000			.015
6	1	.000	.000	-.151	2.267	1.748
			29.611	.000	.032	
			60.000	.155	2.387	
			60.000			1.748
7	1	.000	.000	-.157	2.387	2.138
			30.873	.000	-.044	
			60.000	.149	2.119	
			60.000			2.138
8	1	.000	.000	-.148	2.119	2.205
			29.094	.000	-.039	
			60.000	.158	2.397	
			60.000			2.205
9	1	.000	.000	-.267	4.094	1.968
			52.384	.000	-2.904	
			60.000	.039	-2.756	
			60.000			1.968
10	1	.000	.000	-.710	17.056	-5.114
			42.200	-.495	-8.379	
			42.200			-5.114
11	1	.000	.000	-.131	.329	2.435
			25.690	.000	-1.354	
			60.000	.175	1.648	
			60.000			2.435
12	1	.000	.000			.123

		.000	-.107	-1.165		.000	.000	.000	
		20.943	.000	-2.284		72.000	.000	.000	
		60.000	.199	1.606		72.000			1.155
		60.000			.123				
13		-----							
	1	.000			-1.550				
		.000	-.154	1.606		.000	.000	.000	
		30.125	.000	-.708		72.000	.000	.000	
		60.000	.152	1.568		72.000			.784
		60.000			-1.550				
14		-----							
	1	.000			-2.912				
		.000	-.150	1.568		.000	.013	-.918	
		29.397	.000	-.636		72.000	.013	.000	
		60.000	.156	1.753		72.000			.361
		60.000			-2.912				
15		-----							
	1	.000			-3.932				
		.000	-.146	1.753		.000			
		28.720	.000	-.351		72.000			
		60.000	.160	2.144		72.000			.361
		60.000			-3.932				
16		-----							
	1	.000			-3.932				
		.000	-.156	2.144		.000			
		30.594	.000	-.242		31.169	.000	-15.556	
		60.000	.150	1.963		72.000	1.907	23.373	
		60.000			-3.932	72.000			-4.317
17		-----							
	1	.000			-4.646				
		.000	-.148	1.963		.000			
		29.029	.000	-.186		93.723	.063	-4.444	
		60.000	.158	2.260		93.723	.063	1.417	
		60.000			-4.646	93.723			3.196
18		-----							
	1	.000			-5.036				
		.000	-.158	2.260		.000	.000	.000	
		31.075	.000	-.203		93.723	.000	.000	
		60.000	.148	1.931		93.723			2.589
		60.000			-5.036				
19		-----							
	1	.000			-5.090				
		.000	-.133	1.931		.000	.000	.000	
		26.020	.000	.204		93.723	.000	.000	
		60.000	.173	3.149		93.723			2.129
		60.000			-5.090				
20		-----							
	1	.000			-4.942				
		.000	-.321	5.431		.000	.000	.000	
		60.000	-.015	-4.676		93.723	.000	.000	
		60.000			-4.942	93.723			1.592
21		-----							
	1	.000			3.206				
		.000	.363	-15.660		.000	.000	.000	
		72.000	.363	10.499		93.723	.000	.000	
		72.000			3.206	93.723			-1.116
22		-----							
	1	.000			-2.213				
		.000	-.314	15.357		.000	.000	.000	
		72.000	-.314	-7.257		93.723	.000	.000	
		72.000			-2.213	93.723			-609
23		-----							
	1	.000			-1.636				
		.000	-.015	1.074		.000	.000	.000	
		72.000	-.015	.000		93.723	.000	.000	
		72.000			-1.636	93.723			-105
24		-----							
	1	.000			-1.333				
		.000	.000	.000		.035	.035	-.780	
		72.000	.000	.000		93.723	.035	2.544	
		72.000			-1.333	93.723			.308
25		-----							
	1	.000			-.920				
		.000	.000	.000		.000	.000	20.829	
		72.000	.000	.000		93.723	-.422	-18.697	
		72.000			-.920	93.723			5.248
26		-----							
	1	.000			.316				
		.000	.000	.000		.000	5.911	-57.976	
		72.000	.000	.000		17.800	6.002	48.056	
		72.000			.316	17.800			-3.261
27		-----							
	1	.000			1.155				
		.000				.067	.067	-37.335	
		72.000				59.680		-33.344	
		72.000							-9.529
28		-----							
	1	.000			.784				
		.000	.000	.000		.000	.000	.000	
		72.000	.000	.000		72.000	.000	.000	
		72.000			.784				
29		-----							
	1	.000			.361				
		.000				.013			
		72.000	.013	.000		72.000			
		72.000			.361				
30		-----							
	1	.000			.281				
		.000	-.076	5.239		.000	-.076	-.262	
		72.000			.281	72.000			
		72.000							
31		-----							
	1	.000			-4.317				
		.000	-1.456	7.129		.000			
		31.169	.000	-15.556		72.000	1.907	23.373	
		72.000			-4.317	72.000			
32		-----							
	1	.000			-3.688				
		.000	-.377	10.170		.000			
		93.723	-.377	-25.204		93.723			
		93.723			-3.688	93.723			
33		-----							
	1	.000			3.196				
		.000	.063	-4.444		.063			
		93.723	.063	1.417		93.723			
		93.723			3.196				
34		-----							
	1	.000			2.589				
		.000	.000	.000		.000	.000	.000	
		93.723	.000	.000		93.723	.000	.000	
		93.723			2.589				
35		-----							
	1	.000			2.129				
		.000	.000	.000		.000	.000	.000	
		93.723	.000	.000		93.723			
		93.723			2.129				
36		-----							
	1	.000			1.592				
		.000	.000	.000		.000	.000	.000	
		93.723	.000	.000		93.723	.000	.000	
		93.723			1.592				
37		-----							
	1	.000			-1.116				
		.000	.000	.000		.000	.000	.000	
		93.723	.000	.000		93.723	.000	.000	
		93.723			-1.116				
38		-----							
	1	.000			-.609				
		.000	.000	.000		.000	.000	.000	
		93.723	.000	.000		93.723	.000	.000	
		93.723			-.609				
39		-----							
	1	.000			-.105				
		.000	.000	.000		.000	.000	.000	
		93.723	.000	.000		93.723	.000	.000	
		93.723			-.105				
40		-----							
	1	.000			.308				
		.000	.035	-.780		.035			
		93.723	.035	2.544		93.723			
		93.723			.308				
41		-----							
	1	.000			5.248				
		.000	-.422	20.829		.000			
		93.723	-.422	-18.697		93.723			
		93.723			5.248				
42		-----							
	1	.000			-3.261				
		.000	5.911	-57.976		.000			
		17.800	6.002	48.056		17.800			
		17.800			-3.261				
43		-----							
	1	.000			-9.529				
		.000	.067	-37.335		.067			
		59.680	.067	-33.344					

		59.680			-9.529
44		-----			
	1	.000			4.295
		.000	3.793	-158.934	
		42.200	3.793	1.133	
		42.200			4.295
45		-----			
	1	.000			-2.490
		.000	-2.898	220.447	
		143.800	-2.898	-196.270	
		143.800			-2.490
46		-----			
	1	.000			-2.490
		.000	-2.898	237.835	
		6.000	-2.898	220.447	
		6.000			-2.490
47		-----			
	1	.000			-.991
		.000	3.621	-28.824	
		17.800	3.712	36.437	
		17.800			-.991
48		-----			
	1	.000			6.042
		.000	.212	-32.021	
		59.680	.212	-19.382	
		59.680			6.042
49		-----			
	1	.000			-4.812
		.000	2.814	-121.054	
		42.200	3.658	15.507	
		42.200			-4.812
50		-----			
	1	.000			-.390
		.000	-4.185	241.873	
		143.800	-1.309	-153.075	
		143.800			-.390
51		-----			
	1	.000			-.390
		.000	-4.305	267.340	
		6.000	-4.185	241.873	
		6.000			-.390

**Appendix F: Analytical Results for
Members and Joints in Area
A**

Table F1: Structural Analysis of Area A, Building 8, CCAD

Section Properties

Member ID,	#	Area (In ²)	Inertia (In ⁴)	Centroid (In)
AB	25	74.3	1128	6.750
BC	13	78.8	831	5.625
CD	14	78.8	831	5.625
DE	15	78.8	831	5.625
EF	16	78.8	831	5.625
FG	17	78.8	831	5.625
GH	18	78.8	831	5.625
HI	19	78.8	831	5.625
IJ	20	78.8	831	5.625
JK	21	78.8	831	5.625
KL	22	78.8	831	5.625
LM	23	78.8	831	5.625
MN	24	78.8	831	5.625
NO	37	74.3	1128	6.750
OP	12	78.8	831	5.625
PQ	11	78.8	831	5.625
QR	10	78.8	831	5.625
RS	9	78.8	831	5.625
ST	8	78.8	831	5.625
TU	7	78.8	831	5.625
UV	6	78.8	831	5.625
VW	5	78.8	831	5.625
WX	4	78.8	831	5.625
XY	3	78.8	831	5.625
YZ	2	78.8	831	5.625
ZA	1	78.8	831	5.625
BZ	38	56.3	593	5.625
ZC	26	74.3	1128	6.750
CY	39	56.3	593	5.625
YD	27	63.3	697	5.750
DX	40	56.3	593	5.625
XE	28	63.3	697	5.750
EW	41	56.3	593	5.625
WF	29	52.3	393	4.750
FV	42	36.3	159	3.625
VG	30	30.3	76	2.750
GU	43	18.1	79	3.625
UH	31	30.3	76	2.750
UI	44	18.1	79	3.625
IT	32	30.3	76	2.750
TJ	45	36.3	159	3.625
JS	33	52.3	393	4.750
SK	46	56.3	593	5.625
KR	34	63.3	697	5.750
RL	47	56.3	593	5.625
LQ	35	63.3	697	5.750
QM	48	56.3	593	5.625
MP	36	74.3	1128	6.750
PN	49	56.3	593	5.625
AA'	50	180.0	3375	7.500
OO'	51	180.0	3375	7.500

Table F2: Structural Analysis of Area A, Building 8, CCAD

Reaction and Stresses Due to Dead Loads

Member ID,	#	Shear (kip)	Axial (kip)	Moment (kip-in)	Stress (ksi)		
					fv	fc,t	fb
AB	25	0.101	-12.340	-20.873	0.002	-0.166	-0.125
BC	13	0.814	-9.347	-18.063	0.016	-0.119	-0.122
CD	14	-1.479	-17.302	-21.083	-0.028	-0.220	-0.143
DE	15	-0.717	-22.842	-12.550	-0.014	-0.290	-0.085
EF	16	0.621	-26.533	-9.189	0.012	-0.337	-0.062
FG	17	0.602	-28.198	11.237	0.011	-0.358	0.076
GH	18	-0.640	-28.277	9.452	-0.012	-0.359	0.064
HI	19	0.641	-28.277	9.483	0.012	-0.359	0.064
IJ	20	-0.603	-28.198	11.193	-0.011	-0.358	0.076
JK	21	-0.614	-26.518	-8.664	-0.012	-0.337	-0.059
KL	22	0.421	-22.884	-12.812	0.008	-0.291	-0.087
LM	23	-0.841	-17.302	-21.273	-0.016	-0.220	-0.144
MN	24	-0.813	-9.347	-18.063	-0.015	-0.119	-0.122
NO	37	-0.101	-12.319	20.862	-0.002	-0.166	0.125
OP	12	-1.479	-0.599	-66.751	-0.028	-0.008	-0.452
PQ	11	-0.717	9.237	-12.797	-0.014	0.117	-0.087
QR	10	-0.740	16.961	-13.863	-0.014	0.215	-0.094
RS	9	-0.610	22.474	-8.139	-0.012	0.285	-0.055
ST	8	-0.585	25.992	10.397	-0.011	0.330	0.070
TU	7	0.588	27.673	10.255	0.011	0.351	0.069
UV	6	-0.590	27.673	10.397	-0.011	0.351	0.070
VW	5	0.600	25.992	9.940	0.011	0.330	0.067
WX	4	0.613	22.450	8.885	0.012	0.285	0.060
XY	3	0.725	16.961	-13.495	0.014	0.215	-0.091
YZ	2	0.721	9.242	-12.886	0.014	0.117	-0.087
ZA	1	1.479	-0.599	-66.740	0.028	-0.008	-0.452
BZ	38	-0.113	14.598	9.378	-0.003	0.259	0.089
ZC	26	-0.412	-10.765	28.172	-0.008	-0.145	0.169
CY	39	-0.043	11.920	4.085	-0.001	0.212	0.039
YD	27	-0.197	-8.102	-12.655	-0.005	-0.128	-0.104
DX	40	-0.029	8.717	4.805	-0.001	0.155	0.046
XE	28	-0.124	-5.792	8.895	-0.003	-0.092	0.073
EW	41	-0.040	5.808	4.568	-0.001	0.103	0.043
WF	29	0.000	-3.466	0.000	0.000	-0.066	0.000
FV	42	0.000	2.820	0.000	0.000	0.078	0.000
VG	30	0.000	-1.155	0.000	0.000	-0.038	0.000
GU	43	0.000	0.125	0.000	0.000	0.007	0.000
UH	31	0.000	0.977	0.000	0.000	0.032	0.000
UI	44	0.000	0.122	0.000	0.000	0.007	0.000
IT	32	0.000	-1.155	0.000	0.000	-0.038	0.000
TJ	45	0.000	2.836	0.000	0.000	0.078	0.000
JS	33	0.000	-3.492	0.000	0.000	-0.067	0.000
SK	46	0.023	5.829	3.754	0.001	0.104	0.036
KR	34	0.119	-5.797	-8.234	0.003	-0.092	-0.068
RL	47	0.051	8.717	5.829	0.001	0.155	0.055
LQ	35	0.194	-8.087	-12.516	0.005	-0.128	-0.103
QM	48	0.044	11.920	4.180	0.001	0.212	0.040
MP	36	0.412	-10.765	-28.145	0.008	-0.145	-0.168
PN	49	0.113	14.598	9.347	0.003	0.259	0.089
AA'	50	-0.499	-13.810	-87.587	-0.004	-0.077	-0.195
OO'	51	0.499	-13.810	87.618	0.004	-0.077	0.195

Table F3: Structural Analysis of Area A, Building 8, CCAD

Reaction and Stresses Due to Live Loads

Member ID,	#	Shear (kip)	Axial (kip)	Moment (kip-in)	Stress (ksi)		
					fv	fc,t	fb
AB	25	0.092	-11.160	-18.877	0.002	-0.150	-0.113
BC	13	0.736	-8.453	-16.337	0.014	-0.107	-0.111
CD	14	-1.338	-15.648	-19.067	-0.025	-0.199	-0.129
DE	15	-0.649	-20.658	-11.350	-0.012	-0.262	-0.077
EF	16	0.562	-23.997	-8.311	0.011	-0.305	-0.056
FG	17	0.544	-25.502	10.163	0.010	-0.324	0.069
GH	18	-0.579	-25.573	8.548	-0.011	-0.325	0.058
HI	19	0.579	-25.573	8.577	0.011	-0.325	0.058
IJ	20	-0.546	-25.502	10.123	-0.010	-0.324	0.069
JK	21	-0.556	-23.982	-7.836	-0.011	-0.305	-0.053
KL	22	0.381	-20.696	-11.588	0.007	-0.263	-0.078
LM	23	-0.761	-15.648	-19.239	-0.014	-0.199	-0.130
MN	24	-0.736	-8.453	-16.337	-0.014	-0.107	-0.111
NO	37	-0.092	-11.141	18.868	-0.002	-0.150	0.113
OP	12	-1.338	-0.541	-60.369	-0.025	-0.007	-0.409
PQ	11	-0.649	8.353	-11.573	-0.012	0.106	-0.078
QR	10	-0.669	15.339	-12.537	-0.013	0.195	-0.085
RS	9	-0.552	20.326	-7.361	-0.011	0.258	-0.050
ST	8	-0.529	23.508	9.403	-0.010	0.298	0.064
TU	7	0.531	25.027	9.275	0.010	0.318	0.063
UV	6	-0.534	25.027	9.403	-0.010	0.318	0.064
VW	5	0.542	23.508	8.990	0.010	0.298	0.061
WX	4	0.554	20.304	8.035	0.011	0.258	0.054
XY	3	0.655	15.339	-12.205	0.012	0.195	-0.083
YZ	2	0.652	8.358	-11.654	0.012	0.106	-0.079
ZA	1	1.337	-0.541	-60.360	0.025	-0.007	-0.409
BZ	38	-0.103	13.202	8.482	-0.003	0.235	0.080
ZC	26	-0.372	-9.735	25.478	-0.008	-0.131	0.153
CY	39	-0.038	10.780	3.695	-0.001	0.192	0.035
YD	27	-0.178	-7.328	-11.445	-0.004	-0.116	-0.094
DX	40	-0.027	7.883	4.345	-0.001	0.140	0.041
XE	28	-0.113	-5.238	8.045	-0.003	-0.083	0.066
EW	41	-0.036	5.252	4.132	-0.001	0.093	0.039
WF	29	0.000	-3.134	0.000	0.000	-0.060	0.000
FV	42	0.000	2.550	0.000	0.000	0.070	0.000
VG	30	0.000	-1.045	0.000	0.000	-0.035	0.000
GU	43	0.000	0.114	0.000	0.000	0.006	0.000
UH	31	0.000	0.883	0.000	0.000	0.029	0.000
UI	44	0.000	0.111	0.000	0.000	0.006	0.000
IT	32	0.000	-1.045	0.000	0.000	-0.035	0.000
TJ	45	0.000	2.564	0.000	0.000	0.071	0.000
JS	33	0.000	-3.158	0.000	0.000	-0.060	0.000
SK	46	0.020	5.271	3.396	0.001	0.094	0.032
KR	34	0.108	-5.243	-7.446	0.003	-0.083	-0.061
RL	47	0.046	7.883	5.271	0.001	0.140	0.050
LQ	35	0.176	-7.313	-11.320	0.004	-0.116	-0.093
QM	48	0.039	10.780	3.780	0.001	0.192	0.036
MP	36	0.373	-9.735	-25.455	0.008	-0.131	-0.152
PN	49	0.103	13.202	8.453	0.003	0.235	0.080
AA'	50	-0.452	-12.490	-79.213	-0.004	-0.069	-0.176
OO'	51	0.452	-12.490	79.242	0.004	-0.069	0.176

Table F4: Structural Analysis of Area A, Building 8, CCAD

Reaction and Stresses Due to Point Loads

Member ID,	#	Shear (kip)	Axial (kip)	Moment (kip-in)	Stress (ksi)		
					fv	fc,t	fb
AB	25	0.241	-15.300	-33.200	0.005	-0.206	-0.199
BC	13	0.355	-12.000	21.140	0.007	-0.152	0.143
CD	14	0.323	-22.400	18.300	0.006	-0.284	0.124
DE	15	0.192	-29.700	15.730	0.004	-0.377	0.107
EF	16	0.058	-34.400	6.770	0.001	-0.437	0.046
FG	17	0.036	-36.600	10.400	0.001	-0.465	0.070
GH	18	-0.105	-36.700	10.420	-0.002	-0.466	0.071
HI	19	0.106	-36.700	10.500	0.002	-0.466	0.071
IJ	20	-0.039	-36.600	10.500	-0.001	-0.465	0.071
JK	21	-0.051	-34.400	6.600	-0.001	-0.437	0.045
KL	22	-0.191	-29.670	15.300	-0.004	-0.377	0.104
LM	23	-0.331	-22.400	18.900	-0.006	-0.284	0.128
MN	24	-0.355	-12.000	21.080	-0.007	-0.152	0.143
NO	37	-0.240	-15.300	33.200	-0.005	-0.206	0.199
OP	12	-1.203	-0.868	-76.530	-0.023	-0.011	-0.518
PQ	11	-0.170	11.890	13.800	-0.003	0.151	0.093
QR	10	-0.206	21.970	15.420	-0.004	0.279	0.104
RS	9	-0.040	29.200	6.440	-0.001	0.371	0.044
ST	8	-0.023	33.760	8.700	0.000	0.429	0.059
TU	7	0.043	35.950	8.720	0.001	0.456	0.059
UV	6	-0.046	35.950	9.020	-0.001	0.456	0.061
VW	5	0.039	33.773	9.020	0.001	0.429	0.061
WX	4	0.042	29.150	7.326	0.001	0.370	0.050
XY	3	0.188	21.970	14.080	0.004	0.279	0.095
YZ	2	0.173	11.890	14.080	0.003	0.151	0.095
ZA	1	1.202	-0.870	43.730	0.023	-0.011	0.296
BZ	38	-0.129	18.930	10.130	-0.003	0.336	0.096
ZC	26	-0.541	-12.500	37.000	-0.011	-0.168	0.221
CY	39	-0.052	15.600	5.160	-0.001	0.277	0.049
YD	27	-0.245	-9.090	-15.770	-0.006	-0.144	-0.130
DX	40	-0.037	11.370	5.980	-0.001	0.202	0.057
XE	28	-0.153	-6.080	10.940	-0.004	-0.096	0.090
EW	41	-0.047	11.400	5.560	-0.001	0.203	0.053
WF	29	0.000	-3.030	0.000	0.000	-0.058	0.000
FV	42	0.000	3.670	0.000	0.000	0.101	0.000
VG	30	0.000	-0.046	0.000	0.000	-0.002	0.000
GU	43	0.000	0.225	0.000	0.000	0.012	0.000
UH	31	0.000	2.750	0.000	0.000	0.091	0.000
UI	44	0.000	0.222	0.000	0.000	0.012	0.000
IT	32	0.000	-0.041	0.000	0.000	-0.001	0.000
TJ	45	0.000	3.640	0.000	0.000	0.100	0.000
JS	33	0.000	-3.050	0.000	0.000	-0.058	0.000
SK	46	0.028	7.590	4.670	0.001	0.135	0.044
KR	34	0.147	-6.080	-10.200	0.003	-0.096	-0.084
RL	47	0.061	11.360	7.170	0.002	0.202	0.068
LQ	35	0.243	-9.070	-15.640	0.006	-0.143	-0.129
QM	48	0.054	15.600	5.260	0.001	0.277	0.050
MP	36	0.541	-12.500	-36.980	0.011	-0.168	-0.221
PN	49	0.128	18.960	10.120	0.003	0.337	0.096
AA'	50	-0.627	-16.500	-109.700	-0.005	-0.092	-0.244
OO'	51	0.627	-16.500	109.700	0.005	-0.092	0.244

Table F5: Structural Analysis of Area A, Building 8, CCAD

Reaction and Stresses Due to Wind Loads

Member ID,	#	Shear (kip)	Axial (kip)	Moment (kip-in)	Stress (ksi)		
					fv	fc,t	fb
AB	25	-5.450	14.590	215.300	-0.110	0.196	1.289
BC	13	1.384	7.180	-45.530	0.026	0.091	-0.308
CD	14	-1.358	19.250	45.500	-0.026	0.244	0.308
DE	15	-0.972	27.740	15.300	-0.019	0.352	0.104
EF	16	-0.855	33.600	13.920	-0.016	0.427	0.094
FG	17	-0.819	36.720	-15.030	-0.016	0.466	-0.102
GH	18	-0.692	37.600	-12.730	-0.013	0.477	-0.086
HI	19	-0.876	37.600	-13.200	-0.017	0.477	-0.089
IJ	20	-0.743	38.260	-15.800	-0.014	0.486	-0.107
JK	21	-0.737	36.730	-11.760	-0.014	0.466	-0.080
KL	22	-0.563	32.640	18.140	-0.011	0.414	0.123
LM	23	0.930	25.890	-14.870	0.018	0.329	-0.101
MN	24	1.780	16.450	75.830	0.034	0.209	0.514
NO	37	-2.850	19.090	243.800	-0.058	0.257	1.459
OP	12	-2.970	-6.380	-157.740	-0.057	-0.081	-1.068
PQ	11	1.370	-20.140	46.110	0.026	-0.256	0.312
QR	10	0.916	-29.610	-14.390	0.017	-0.376	-0.097
RS	9	0.822	-36.200	-11.860	0.016	-0.460	-0.080
ST	8	0.806	-40.200	-15.090	0.015	-0.510	-0.102
TU	7	-0.815	-41.700	-14.650	-0.016	-0.529	-0.099
UV	6	0.794	-40.200	-13.560	0.015	-0.510	-0.092
VW	5	-0.812	-37.090	-12.700	-0.015	-0.471	-0.086
WX	4	-0.834	-31.400	-12.120	-0.016	-0.399	-0.082
XY	3	-1.050	-23.000	23.100	-0.020	-0.292	0.156
YZ	2	0.946	-11.500	-21.400	0.018	-0.146	-0.145
ZA	1	-5.220	1.916	323.500	-0.099	0.024	2.191
BZ	38	0.650	-18.930	-56.200	0.017	-0.336	-0.533
ZC	26	0.791	17.200	-66.000	0.016	0.232	-0.395
CY	39	-0.023	-17.900	2.470	-0.001	-0.318	0.023
YD	27	0.284	11.950	19.560	0.007	0.189	0.161
DX	40	0.049	-13.300	-7.970	0.001	-0.236	-0.076
XE	28	0.189	9.100	-13.700	0.004	0.144	-0.113
EW	41	0.061	-9.340	-6.620	0.002	-0.166	-0.063
WF	29	0.000	5.870	0.000	0.000	0.112	0.000
FV	42	0.000	-5.230	0.000	0.000	-0.144	0.000
VG	30	0.000	2.700	0.000	0.000	0.089	0.000
GU	43	0.000	-1.509	0.000	0.000	-0.083	0.000
UH	31	0.000	-1.260	0.000	0.000	-0.042	0.000
UI	44	0.000	1.075	0.000	0.000	0.059	0.000
IT	32	0.000	0.529	0.000	0.000	0.017	0.000
TJ	45	0.000	-2.523	0.000	0.000	-0.070	0.000
JS	33	0.000	3.650	0.000	0.000	0.070	0.000
SK	46	-0.032	-6.540	-5.350	-0.001	-0.116	-0.051
KR	34	-0.132	6.750	9.100	-0.003	0.107	0.075
RL	47	-0.049	-10.470	-6.230	-0.001	-0.186	-0.059
LQ	35	-0.240	10.110	16.770	-0.006	0.160	0.138
QM	48	-0.137	-14.530	-13.420	-0.004	-0.258	-0.127
MP	36	-0.238	12.300	-24.860	-0.005	0.166	-0.149
PN	49	0.267	-21.440	22.240	0.007	-0.381	0.211
AA'	50	7.971	19.800	-882.459	0.066	0.110	-1.961
OO'	51	3.530	17.700	-595.080	0.029	0.098	-1.322

Table F6: Structural Analysis of Area A, Building 8, CCAD

Actual Total Stresses

Member ID, #	Load Comb.=D.L+L.L+Point L.				Load Comb.=D.L+W.L+Point L.			
	fv	ft	fc	fb	fv	ft	fc	fb
AB 25	0.009		-0.523	-0.437	-0.103		-0.176	0.965
BC 13	0.036		-0.378	-0.090	0.049		-0.180	-0.288
CD 14	-0.047		-0.703	-0.148	-0.048		-0.260	0.289
DE 15	-0.022		-0.929	-0.055	-0.029		-0.315	0.125
EF 16	0.024		-1.078	-0.073	-0.003		-0.347	0.078
FG 17	0.023		-1.147	0.215	-0.003		-0.356	0.045
GH 18	-0.025		-1.150	0.192	-0.027		-0.348	0.048
HI 19	0.025		-1.150	0.193	-0.002		-0.348	0.046
IJ 20	-0.023		-1.147	0.215	-0.026		-0.337	0.040
JK 21	-0.023		-1.078	-0.067	-0.027		-0.307	-0.094
KL 22	0.012		-0.930	-0.062	-0.006		-0.253	0.140
LM 23	-0.037		-0.703	-0.146	-0.005		-0.175	-0.117
MN 24	-0.036		-0.378	-0.090	0.012		-0.062	0.534
NO 37	-0.009		-0.522	0.437	-0.064		-0.115	1.783
OP 12	-0.077		-0.025	-1.379	-0.108		-0.100	-2.039
PQ 11	-0.029	0.374		-0.072	0.009	0.013		0.319
QR 10	-0.031	0.689		-0.074	-0.001	0.118		-0.087
RS 9	-0.023	0.914		-0.061	0.003	0.196		-0.092
ST 8	-0.022	1.057		0.193	0.004	0.248		0.027
TU 7	0.022	1.126		0.191	-0.004	0.278		0.029
UV 6	-0.022	1.126		0.195	0.003	0.297		0.040
VW 5	0.022	1.057		0.189	-0.003	0.288		0.042
WX 4	0.023	0.913		0.164	-0.003	0.256		0.028
XY 3	0.030	0.689		-0.079	-0.003	0.202		0.160
YZ 2	0.029	0.374		-0.071	0.035	0.122		-0.137
ZA 1	0.077		-0.026	-0.565	-0.048	0.006		2.035
BZ 38	-0.009	0.831		0.265	0.011	0.259		-0.348
ZC 26	-0.027		-0.444	0.543	-0.003		-0.082	-0.005
CY 39	-0.004	0.681		0.123	-0.003	0.171		0.111
YD 27	-0.015		-0.388	-0.329	-0.004		-0.083	-0.073
DX 40	-0.002	0.497		0.143	0.000	0.121		0.027
XE 28	-0.009		-0.271	0.230	-0.002		-0.044	0.051
EW 41	-0.003	0.399		0.135	-0.001	0.140		0.033
WF 29	0.000		-0.184	0.000	0.000		-0.012	0.000
FV 42	0.000	0.249		0.000	0.000	0.035		0.000
VG 30	0.000		-0.074	0.000	0.000	0.050		0.000
GU 43	0.000	0.026		0.000	0.000		-0.064	0.000
UH 31	0.000	0.152		0.000	0.000	0.082		0.000
UI 44	0.000	0.025		0.000	0.000	0.078		0.000
IT 32	0.000		-0.074	0.000	0.000		-0.022	0.000
TJ 45	0.000	0.249		0.000	0.000	0.109		0.000
JS 33	0.000		-0.186	0.000	0.000		-0.055	0.000
SK 46	0.002	0.332		0.112	0.000	0.122		0.029
KR 34	0.009		-0.271	-0.213	0.003		-0.081	-0.077
RL 47	0.004	0.497		0.173	0.002	0.171		0.064
LQ 35	0.015		-0.387	-0.326	0.005		-0.111	-0.094
QM 48	0.004	0.681		0.125	-0.001	0.231		-0.038
MP 36	0.027		-0.444	-0.542	0.014		-0.148	-0.539
PN 49	0.009	0.831		0.265	0.014	0.215		0.395
AA' 50	-0.013		-0.238	-0.614	0.057		-0.058	-2.399
OO' 51	0.013		-0.238	0.615	0.039		-0.070	-0.884

Table F7: Allowable Stresses

Laboratory Test (ksi)		NDS (ksi), Unfactored	
Fv=	0.190	Fv=	0.090
Ft=	1.690	Ft=	1.350
Fc=	3.875	Fc=	2.050
Fb=	5.100	Fb=	2.450

Density=46.4 lb.ft³

Table F8: Structural Analysis of Area A, Building 8, CCAD

Adjustment Factors from NDS Specifications and Factored Allowables

Member ID, #	Load Comb.: D.L+L.L+P.L for : Fb=3.05, Ft=1.65, Fv=0.1, Fc=2.25									(ksi)			
	Cd	Cm	Ct	Cfu	Cv<1.0	Cf	Cp	Ch	F'b	F't	F'v	F'c	
AB 25	1.25	1	1	1	1	1.10	0.893	1	3.369	1.856	0.113	2.517	
BC 13	1.25	1	1	1	1	1.10	1.000	1	3.369	1.856	0.113	2.819	
CD 14	1.25	1	1	1	1	1.10	1.000	1	3.369	1.856	0.113	2.819	
DE 15	1.25	1	1	1	1	1.10	1.000	1	3.369	1.856	0.113	2.819	
EF 16	1.25	1	1	1	1	1.10	1.000	1	3.369	1.856	0.113	2.819	
FG 17	1.25	1	1	1	1	1.10	1.000	1	3.369	1.856	0.113	2.819	
GH 18	1.25	1	1	1	1	1.10	1.000	1	3.369	1.856	0.113	2.819	
HI 19	1.25	1	1	1	1	1.10	1.000	1	3.369	1.856	0.113	2.819	
IJ 20	1.25	1	1	1	1	1.10	1.000	1	3.369	1.856	0.113	2.819	
JK 21	1.25	1	1	1	1	1.10	1.000	1	3.369	1.856	0.113	2.819	
KL 22	1.25	1	1	1	1	1.10	1.000	1	3.369	1.856	0.113	2.819	
LM 23	1.25	1	1	1	1	1.10	1.000	1	3.369	1.856	0.113	2.819	
MN 24	1.25	1	1	1	1	1.10	1.000	1	3.369	1.856	0.113	2.819	
NO 37	1.25	1	1	1	1	1.10	0.893	1	3.369	1.856	0.113	2.517	
OP 12	1.25	1	1	1	1	1.10	1.000	1	3.369	1.856	0.113	2.819	
PQ 11	1.25	1	1	1	1	1.10	1.000	1	3.369	1.856	0.113	2.819	
QR 10	1.25	1	1	1	1	1.10	1.000	1	3.369	1.856	0.113	2.819	
RS 9	1.25	1	1	1	1	1.10	1.000	1	3.369	1.856	0.113	2.819	
ST 8	1.25	1	1	1	1	1.10	1.000	1	3.369	1.856	0.113	2.819	
TU 7	1.25	1	1	1	1	1.10	1.000	1	3.369	1.856	0.113	2.819	
UV 6	1.25	1	1	1	1	1.10	1.000	1	3.369	1.856	0.113	2.819	
VW 5	1.25	1	1	1	1	1.10	1.000	1	3.369	1.856	0.113	2.819	
WX 4	1.25	1	1	1	1	1.10	1.000	1	3.369	1.856	0.113	2.819	
XY 3	1.25	1	1	1	1	1.10	1.000	1	3.369	1.856	0.113	2.819	
YZ 2	1.25	1	1	1	1	1.10	1.000	1	3.369	1.856	0.113	2.819	
ZA 1	1.25	1	1	1	1	1.10	1.000	1	3.369	1.856	0.113	2.819	
BZ 38	1.25	1	1	1	1	1.10	1.000	1	3.369	1.856	0.113	2.819	
ZC 26	1.25	1	1	1	1	1.10	0.882	1	3.369	1.856	0.113	2.486	
CY 39	1.25	1	1	1	1	1.10	1.000	1	3.369	1.856	0.113	2.819	
YD 27	1.25	1	1	1	1	1.10	0.872	1	3.369	1.856	0.113	2.458	
DX 40	1.25	1	1	1	1	1.10	1.000	1	3.369	1.856	0.113	2.819	
XE 28	1.25	1	1	1	1	1.10	0.862	1	3.369	1.856	0.113	2.430	
EW 41	1.25	1	1	1	1	1.10	1.000	1	3.369	1.856	0.113	2.819	
WF 29	1.25	1	1	1	1	1.10	0.852	1	3.369	1.856	0.113	2.402	
FV 42	1.25	1	1	1	1	1.10	1.000	1	3.369	1.856	0.113	2.819	
VG 30	1.25	1	1	1	1	1.10	0.842	1	3.369	1.856	0.113	2.373	
GU 43	1.25	1	1	1	1	1.10	1.000	1	3.369	1.856	0.113	2.819	
UH 31	1.25	1	1	1	1	1.10	0.832	1	3.369	1.856	0.113	2.345	
UI 44	1.25	1	1	1	1	1.10	1.000	1	3.369	1.856	0.113	2.819	
IT 32	1.25	1	1	1	1	1.10	0.842	1	3.369	1.856	0.113	2.373	
TJ 45	1.25	1	1	1	1	1.10	1.000	1	3.369	1.856	0.113	2.819	
JS 33	1.25	1	1	1	1	1.10	0.852	1	3.369	1.856	0.113	2.402	
SK 46	1.25	1	1	1	1	1.10	1.000	1	3.369	1.856	0.113	2.819	
KR 34	1.25	1	1	1	1	1.10	0.862	1	3.369	1.856	0.113	2.430	
RL 47	1.25	1	1	1	1	1.10	1.000	1	3.369	1.856	0.113	2.819	
LQ 35	1.25	1	1	1	1	1.10	0.872	1	3.369	1.856	0.113	2.458	
QM 48	1.25	1	1	1	1	1.10	1.000	1	3.369	1.856	0.113	2.819	
MP 36	1.25	1	1	1	1	1.10	0.882	1	3.369	1.856	0.113	2.486	
PN 49	1.25	1	1	1	1	1.10	1.000	1	3.369	1.856	0.113	2.819	
AA' 50	1.25	1	1	1	1	1.10	0.370	1	3.369	1.856	0.113	1.043	
OO' 51	1.25	1	1	1	1	1.10	0.370	1	3.369	1.856	0.113	1.043	

Cm=1.0 due to occupancy Live Load
 When Cv is determined, some vales are used conventionally.
 Ch=1.0 for assuming splits at all members.

Table F9: Structural Analysis of Area A, Building 8, CCAD

Adjustment Factors from NDS Specifications and Factored Allowables

Member		Load Comb.: D.L+W.L+P.L for Fb=3.05, Ft=1.65, Fv=0.1, Fc=2.25								(ksi)			
ID,	#	Cd	Cm	Ct	Cfu	Cv<1.0	Cf	Cp	Ch	F'b	F't	F'v	F'c
AB	25	1.60	1	1	1	0.838	1.1	0.893	1	3.614	2.160	0.144	3.222
BC	13	1.60	1	1	1	0.838	1.1	1.000	1	3.614	2.160	0.144	3.608
CD	14	1.60	1	1	1	0.838	1.1	1.000	1	3.614	2.160	0.144	3.608
DE	15	1.60	1	1	1	0.838	1.1	1.000	1	3.614	2.160	0.144	3.608
EF	16	1.60	1	1	1	0.838	1.1	1.000	1	3.614	2.160	0.144	3.608
FG	17	1.60	1	1	1	0.838	1.1	1.000	1	3.614	2.160	0.144	3.608
GH	18	1.60	1	1	1	0.838	1.1	1.000	1	3.614	2.160	0.144	3.608
HI	19	1.60	1	1	1	0.838	1.1	1.000	1	3.614	2.160	0.144	3.608
IJ	20	1.60	1	1	1	0.838	1.1	1.000	1	3.614	2.160	0.144	3.608
JK	21	1.60	1	1	1	0.838	1.1	1.000	1	3.614	2.160	0.144	3.608
KL	22	1.60	1	1	1	0.838	1.1	1.000	1	3.614	2.160	0.144	3.608
LM	23	1.60	1	1	1	0.838	1.1	1.000	1	3.614	2.160	0.144	3.608
MN	24	1.60	1	1	1	0.838	1.1	1.000	1	3.614	2.160	0.144	3.608
NO	37	1.60	1	1	1	0.838	1.1	0.893	1	3.614	2.160	0.144	3.222
OP	12	1.60	1	1	1	0.838	1.1	1.000	1	3.614	2.160	0.144	3.608
PQ	11	1.60	1	1	1	0.838	1.1	1.000	1	3.614	2.160	0.144	3.608
QR	10	1.60	1	1	1	0.838	1.1	1.000	1	3.614	2.160	0.144	3.608
RS	9	1.60	1	1	1	0.838	1.1	1.000	1	3.614	2.160	0.144	3.608
ST	8	1.60	1	1	1	0.838	1.1	1.000	1	3.614	2.160	0.144	3.608
TU	7	1.60	1	1	1	0.838	1.1	1.000	1	3.614	2.160	0.144	3.608
UV	6	1.60	1	1	1	0.838	1.1	1.000	1	3.614	2.160	0.144	3.608
VW	5	1.60	1	1	1	0.838	1.1	1.000	1	3.614	2.160	0.144	3.608
WX	4	1.60	1	1	1	0.838	1.1	1.000	1	3.614	2.160	0.144	3.608
XY	3	1.60	1	1	1	0.838	1.1	1.000	1	3.614	2.160	0.144	3.608
YZ	2	1.60	1	1	1	0.838	1.1	1.000	1	3.614	2.160	0.144	3.608
ZA	1	1.60	1	1	1	0.838	1.1	1.000	1	3.614	2.160	0.144	3.608
BZ	38	1.60	1	1	1	0.838	1.1	1.000	1	3.614	2.160	0.144	3.608
ZC	26	1.60	1	1	1	0.838	1.1	0.882	1	3.614	2.160	0.144	3.182
CY	39	1.60	1	1	1	0.838	1.1	1.000	1	3.614	2.160	0.144	3.608
YD	27	1.60	1	1	1	0.838	1.1	0.872	1	3.614	2.160	0.144	3.146
DX	40	1.60	1	1	1	0.838	1.1	1.000	1	3.614	2.160	0.144	3.608
XE	28	1.60	1	1	1	0.838	1.1	0.862	1	3.614	2.160	0.144	3.110
EW	41	1.60	1	1	1	0.838	1.1	1.000	1	3.614	2.160	0.144	3.608
WF	29	1.60	1	1	1	0.838	1.1	0.852	1	3.614	2.160	0.144	3.074
FV	42	1.60	1	1	1	0.838	1.1	1.000	1	3.614	2.160	0.144	3.608
VG	30	1.60	1	1	1	0.838	1.1	0.842	1	3.614	2.160	0.144	3.038
GU	43	1.60	1	1	1	0.838	1.1	1.000	1	3.614	2.160	0.144	3.608
UH	31	1.60	1	1	1	0.838	1.1	0.832	1	3.614	2.160	0.144	3.002
UI	44	1.60	1	1	1	0.838	1.1	1.000	1	3.614	2.160	0.144	3.608
IT	32	1.60	1	1	1	0.838	1.1	0.842	1	3.614	2.160	0.144	3.038
TJ	45	1.60	1	1	1	0.838	1.1	1.000	1	3.614	2.160	0.144	3.608
JS	33	1.60	1	1	1	0.838	1.1	0.852	1	3.614	2.160	0.144	3.074
SK	46	1.60	1	1	1	0.838	1.1	1.000	1	3.614	2.160	0.144	3.608
KR	34	1.60	1	1	1	0.838	1.1	0.862	1	3.614	2.160	0.144	3.110
RL	47	1.60	1	1	1	0.838	1.1	1.000	1	3.614	2.160	0.144	3.608
LQ	35	1.60	1	1	1	0.838	1.1	0.872	1	3.614	2.160	0.144	3.146
QM	48	1.60	1	1	1	0.838	1.1	1.000	1	3.614	2.160	0.144	3.608
MP	36	1.60	1	1	1	0.838	1.1	0.882	1	3.614	2.160	0.144	3.182
PN	49	1.60	1	1	1	0.838	1.1	1.000	1	3.614	2.160	0.144	3.608
AA'	50	1.60	1	1	1	0.838	1.1	0.370	1	3.614	2.160	0.144	1.335
OO'	51	1.60	1	1	1	0.838	1.1	0.370	1	3.614	2.160	0.144	1.335

Cd=1.6 due to Wind Load

When Cv is determined, some vales are used conventionally.

Ch=1.0 for assuming splits at all members.

Table F10: Structural Analysis of Area A, Building 8, CCAD

Stress Interaction Per NDS Allowables

Member ID,	#	Load Comb.:D.L+L.L+Point L.			Load Comb.:D.L+W.L+Point L.		
		I (b,t)*	I (b,t)**	I (b,c)***	I (b,t)*	I (b,t)**	I (b,c)***
AB	25			0.207			0.285
BC	13			0.049			0.086
CD	14			0.121			0.091
DE	15			0.133			0.046
EF	16			0.181			0.033
FG	17			0.273			0.024
GH	18			0.263			0.024
HI	19			0.263			0.023
IJ	20			0.273			0.021
JK	21			0.178			0.036
KL	22			0.136			0.046
LM	23			0.120			0.036
MN	24			0.049			0.151
NO	37			0.207			0.513
OP	12			0.413			0.581
PQ	11	0.223	0.090		0.094	0.085	
QR	10	0.393	0.182		0.079	0.009	
RS	9	0.511	0.253		0.116	0.029	
ST	8	0.627	0.257		0.122	0.061	
TU	7	0.663	0.277		0.137	0.069	
UV	6	0.664	0.276		0.149	0.071	
VW	5	0.626	0.258		0.145	0.068	
WX	4	0.541	0.222		0.126	0.063	
XY	3	0.395	0.181		0.138	0.012	
YZ	2	0.223	0.090		0.094	0.004	
ZA	1			0.169	0.566	0.562	
BZ	38	0.526	0.168		0.216	0.024	
ZC	26			0.228			0.002
CY	39	0.403	0.166		0.110	0.017	
YD	27			0.141			0.021
DX	40	0.310	0.105		0.063	0.026	
XE	28			0.089			0.014
EW	41	0.255	0.078		0.074	0.029	
WF	29			0.006			0.000
FV	42	0.134	0.074		0.016	0.010	
VG	30			0.001	0.023	0.014	
GU	43	0.014	0.008				0.000
UH	31	0.082	0.045		0.038	0.023	
UI	44	0.014	0.007		0.036	0.022	
IT	32			0.001			0.000
TJ	45	0.134	0.074		0.050	0.030	
JS	33			0.006			0.000
SK	46	0.212	0.065		0.065	0.026	
KR	34			0.084			0.023
RL	47	0.319	0.096		0.097	0.029	
LQ	35			0.139			0.028
QM	48	0.404	0.165		0.117	0.053	
MP	36			0.228			0.158
PN	49	0.526	0.168		0.209	0.050	
AA'	50			0.288			0.696
OO'	51			0.288			0.261

*: $f_t/F_t + f_b/F_b < 1.0$

** : $(f_b - f_t)/F_b < 1.0$

***: $(f_c/F_c)^2 + f_b/(F_b * (1 - (f_c/F_c))) < 1.0$

Table F11: Structural Analysis of Area A, Building 8, CCAD

Stress Interaction Based on Lab. Test Allowables

Member ID, #	Load Comb.:D.L+L.L+Point L.			Load Comb.:D.L+W.L+Point L.		
	I (b,t)*	I (b,t) **	I (b,c) ***	I (b,t)*	I (b,t) **	I (b,c) ***
AB	25		0.117			0.200
BC	13		0.029			0.061
CD	14		0.068			0.065
DE	15		0.072			0.033
EF	16		0.097			0.025
FG	17		0.148			0.018
GH	18		0.142			0.018
HI	19		0.142			0.018
IJ	20		0.148			0.016
JK	21		0.096			0.026
KL	22		0.074			0.034
LM	23		0.068			0.026
MN	24		0.029			0.107
NO	37		0.117			0.361
OP	12		0.272			0.411
PQ	11	0.236	0.059	0.070	0.060	
QR	10	0.422	0.121	0.087	0.006	
RS	9	0.553	0.167	0.134	0.021	
ST	8	0.663	0.169	0.152	0.043	
TU	7	0.704	0.183	0.170	0.049	
UV	6	0.704	0.182	0.184	0.051	
VW	5	0.663	0.170	0.179	0.048	
WX	4	0.572	0.147	0.157	0.045	
XY	3	0.423	0.120	0.151	0.008	
YZ	2	0.235	0.060	0.099	0.003	
ZA	1		0.111	0.402	0.398	
BZ	38	0.544	0.111	0.222	0.017	
ZC	26		0.133			0.001
CY	39	0.427	0.109	0.123	0.012	
YD	27		0.082			0.015
DX	40	0.322	0.069	0.077	0.018	
XE	28		0.053			0.010
EW	41	0.263	0.052	0.089	0.021	
WF	29		0.002			0.000
FV	42	0.148	0.049	0.021	0.007	
VG	30		0.000	0.029	0.010	
GU	43	0.015	0.005			0.000
UH	31			0.048	0.016	
UI	44	0.015	0.005	0.046	0.015	
IT	32		0.000			0.000
TJ	45	0.148	0.049	0.065	0.021	
JS	33		0.002			0.000
SK	46	0.219	0.043	0.078	0.018	
KR	34		0.050			0.016
RL	47	0.328	0.063	0.114	0.021	
LQ	35		0.081			0.020
QM	48	0.427	0.109	0.144	0.038	
MP	36		0.133			0.111
PN	49	0.544	0.111	0.205	0.035	
AA'	50		0.132			0.478
OO'	51		0.132			0.177

*: $f_t/F_t + f_b/F_b < 1.0$ **: $(f_b - f_t)/F_b < 1.0$ ***: $(f_c/F_c)^2 + f_b/(F_b(1 - (f_c/F_c))) < 1.0$

Table F12: Connection Evaluation in Area A

Load Combination=D.L+L.L+P.L																								
Joint Type	I.D.	Position of Ring	Angle (Deg.)	Angle (Rad.)	# of Bolts	P	Q	OD	CM	CI	Cg	Cd	Cst	P	Q	Sina	Cosa	n'	N(n'#)	Axial Load	Half of Axial Load	Result Load	Half of Result	Interaction
J1(B)	BC	out	0	0.000	4	6.14	4.27	1.25	1	1	0.507	1	1.18	4.59	2.71	0.000	1.000	4.59	18.37	-29.84	-14.92			0.264
	BZ	out	52	0.908	4	6.14	4.27	1.25	1	1	0.507	1	1.18	4.59	2.71	0.788	0.616	3.20	12.82	46.7	23.35			0.378
	BZ	in	0	0.000	4	6.14	4.27	1.25	1	1	0.507	1	1.18	4.59	2.71	0.000	1.000	4.59	18.37	46.7	23.35			0.264
	AB	in	40	0.698	4	6.14	4.27	1.25	1	1	0.507	1	1.18	4.59	2.71	0.643	0.766	3.57	14.26	-38.8	-19.4	9.7	4.85	0.340
J2(E)	XE	in	0	0.000	3	6.14	4.27	1.25	1	1	1.000	1	1.18	9.06	5.34	0.000	1.000	9.06	27.17	-17.2	-8.6			0.404
	EW	in	52	0.908	3	6.14	4.27	1.25	1	1	1.000	1	1.18	9.06	5.34	0.788	0.616	6.32	18.96	18.63	9.315			0.579
	EW	out	0	0.000	3	6.14	4.27	1.25	1	1	1.000	1	1.18	9.06	5.34	0.000	1.000	9.06	27.17	18.63	9.315			0.404
	EF	out	40	0.698	3	6.14	4.27	1.25	1	1	1.000	1	1.18	9.06	5.34	0.643	0.766	7.03	21.10	-84.96	-42.48	21.97	10.99	0.521
J3(H)	UH	in/out	88	1.536	9	6.14	4.27	1.25	1	1	0.335	1	1.18	3.03	1.79	0.999	0.035	1.79	16.10	4.58	2.29	2.29	1.145	0.071
	UH	in	0	0.000	1	6.14	4.27	1.25	1	1	1.000	1	1.18	9.06	5.34	0.000	1.000	9.06	9.06	4.58	2.29			0.148
J4(U)	GU	in	40	0.698	1	6.14	4.27	1.25	1	1	1.000	1	1.18	9.06	5.34	0.643	0.766	7.03	7.03	0.46	0.23			0.191
	GU	out	0	0.000	1	6.14	4.27	1.25	1	1	1.000	1	1.18	9.06	5.34	0.000	1.000	9.06	9.06	0.46	0.23			0.148
J5(X)	VU	out	50	0.873	1	6.14	4.27	1.25	1	1	1.000	1	1.18	9.06	5.34	0.766	0.643	6.43	6.43	86.41	43.205	2.68	1.34	0.208
	XE	in	0	0.000	3	6.14	4.27	1.25	1	1	0.335	1	1.18	3.03	1.79	0.000	1.000	3.03	9.10	-17.2	-8.6			0.736
	DX	in	40	0.698	3	6.14	4.27	1.25	1	1	0.335	1	1.18	3.03	1.79	0.643	0.766	2.96	7.07	27.924	13.962			0.948
	DX	out	0	0.000	3	6.14	4.27	1.25	1	1	0.335	1	1.18	3.03	1.79	0.000	1.000	3.03	9.10	27.924	13.962			0.736
	XY	out	50	0.873	3	6.14	4.27	1.25	1	1	0.335	1	1.18	3.03	1.79	0.766	0.643	2.15	6.46	54.25	27.125			1.037
	XW	out	50	0.873	3	6.14	4.27	1.25	1	1	0.335	1	1.18	3.03	1.79	0.766	0.643	2.15	6.46	71.85	35.925	13.4	6.7	1.037
J6(O)	ZA	out	0	0.000	2	6.14	4.27	1.25	1	1	0.335	1	1.18	3.03	1.79	0.000	1.000	3.03	6.07	-2.01	-1.005	2.01	1.005	0.166

Load Combination=D.L+W.L+P.L																								
Joint Type	I.D.	Position of Ring	Angle (Deg.)	Angle (Rad.)	# of Bolts	P	Q	CD	CM	CI	Cg	Cd	Cst	P	Q	Sina	Cosa	n'	N(n'#)	Axial Load	Half of Axial Load	Result Load	Half of Result	Interaction
J1(B)	BC	out	0	0.000	4	6.14	4.27	1.6	1	1	0.507	1	1.18	5.88	3.46	0.000	1.000	5.88	23.51	-14.2	-7.1			0.113
	BZ	out	52	0.908	4	6.14	4.27	1.6	1	1	0.507	1	1.18	5.88	3.46	0.788	0.616	4.10	16.41	14.6	7.3			0.162
	BZ	in	0	0.000	4	6.14	4.27	1.6	1	1	0.507	1	1.18	5.88	3.46	0.000	1.000	5.88	23.51	14.6	7.3			0.113
	AB	in	40	0.698	4	6.14	4.27	1.6	1	1	0.507	1	1.18	5.88	3.46	0.643	0.766	4.56	18.25	-13.03	-6.5125	5.301	2.651	0.145
J2(E)	XE	in	0	0.000	3	6.14	4.27	1.6	1	1	1.000	1	1.18	11.59	6.83	0.000	1.000	11.59	34.78	-17.2	-8.6			0.038
	EW	in	52	0.908	3	6.14	4.27	1.6	1	1	1.000	1	1.18	11.59	6.83	0.788	0.616	8.09	24.27	18.63	4.06			0.054
	EW	out	0	0.000	3	6.14	4.27	1.6	1	1	1.000	1	1.18	11.59	6.83	0.000	1.000	11.59	34.78	18.63	4.06			0.038
	EF	out	40	0.698	3	6.14	4.27	1.6	1	1	1.000	1	1.18	11.59	6.83	0.643	0.766	9.00	27.00	-84.96	-42.48			0.049
J3(H)	UH	in/out	88	1.536	9	6.14	4.27	1.6	1	1	0.335	1	1.18	3.88	2.29	0.999	0.035	2.29	20.61	2.445	1.22	1.22	0.61	0.056
	UH	in	0	0.000	1	6.14	4.27	1.6	1	1	1.000	1	1.18	11.59	6.83	0.000	1.000	11.59	11.59	2.445	1.2225			0.165
J4(U)	GU	in	40	0.698	1	6.14	4.27	1.6	1	1	1.000	1	1.18	11.59	6.83	0.643	0.766	9.00	9.00	-1.158	-0.579			0.212
	GU	out	0	0.000	1	6.14	4.27	1.6	1	1	1.000	1	1.18	11.59	6.83	0.000	1.000	11.59	11.59	-1.158	-0.579			0.165
J5(X)	VU	out	50	0.873	1	6.14	4.27	1.6	1	1	1.000	1	1.18	11.59	6.83	0.766	0.643	8.23	8.23	-2.788	-1.394	3.82	1.91	0.232
	XE	in	0	0.000	3	6.14	4.27	1.6	1	1	0.335	1	1.18	3.88	2.29	0.000	1.000	3.88	11.65	-2.788	-1.394			0.352
	DX	in	40	0.698	3	6.14	4.27	1.6	1	1	0.335	1	1.18	3.88	2.29	0.643	0.766	3.02	9.05	6.78	3.39			0.453
	DX	out	0	0.000	3	6.14	4.27	1.6	1	1	0.335	1	1.18	3.88	2.29	0.000	1.000	3.88	11.65	6.78	3.39			0.352
J6(O)	XY	out	50	0.873	3	6.14	4.27	1.6	1	1	0.335	1	1.18	3.88	2.29	0.766	0.643	2.76	8.27	16.08	8.04			0.496
	XW	out	50	0.873	3	6.14	4.27	1.6	1	1	0.335	1	1.18	3.88	2.29	0.766	0.643	2.76	8.27	19.98	9.99	8.2	4.1	0.496
J6(O)	ZA	out	0	0.000	2	6.14	4.27	1.6	1	1	0.335	1	1.18	3.88	2.29	0.000	1.000	3.88	7.77	2.01	1.005	2.01	1.005	0.129

**Appendix G: Analytical Results for
Members and Joints in Area
B**

Table G1: Structural Analysis of Area B, Building 8, CCAD

Section Properties				
Member		Area	Inertia	Centroid
ID,	#	(In ²)	(In ⁴)	(In)
BW	1	36.3	158.8	3.625
WT	42	36.3	158.8	3.625
TS	2	36.3	158.8	3.625
SR	3	36.3	158.8	3.625
RQ	4	36.3	158.8	3.625
QP	5	36.3	158.8	3.625
PO	6	36.3	158.8	3.625
ON	7	36.3	158.8	3.625
NX	43	36.3	158.8	3.625
XL	8	36.3	158.8	3.625
CD	9	36.3	158.8	3.625
DE	10	36.3	158.8	3.625
EF	11	36.3	158.8	3.625
FG	12	36.3	158.8	3.625
GH	13	36.3	158.8	3.625
HI	14	36.3	158.8	3.625
IJ	15	36.3	158.8	3.625
JK	16	36.3	158.8	3.625
CB	17	28.1	296.6	5.625
DT	18	28.1	296.6	5.625
ES	19	13.8	34.7	2.750
FR	20	13.8	34.7	2.750
GQ	21	13.8	34.7	2.750
HP	22	13.8	34.7	2.750
IO	23	13.8	34.7	2.750
JN	24	28.1	296.6	5.625
KL	25	28.1	296.6	5.625
CT	26	56.3	593.3	5.625
DS	27	56.3	593.3	5.625
ER	28	36.3	158.8	3.625
FQ	29	13.8	34.7	2.750
HQ	30	13.8	34.7	2.750
IP	31	36.3	158.8	3.625
JO	32	56.3	593.3	5.625
KN	33	56.3	593.3	5.625
A'U	38	95.6	1008.5	5.625
UB	36	95.6	1008.5	5.625
UW	34	56.3	593.3	5.625
M'V	39	95.6	1008.5	5.625
VL	37	95.6	1008.5	5.625
VX	35	56.3	593.3	5.625

Table G2: Structural Analysis of Area B, Building 8, CCAD							
Reaction and Stresses Due to Dead Loads							
Member		Shear	Axial	Moment		Stress (ksi)	
ID,	#	(kip)	(kip)	(kip-in)	fv	fc,t	fb
BW	1	0.342	1.172	3.193	0.014	0.032	0.073
WT	42	-0.476	1.172	-7.197	-0.020	0.032	-0.164
TS	2	0.410	1.732	-4.662	0.017	0.048	-0.106
SR	3	0.417	5.566	-4.623	0.017	0.153	-0.106
RQ	4	0.434	7.909	4.589	0.018	0.218	0.105
QP	5	-0.436	7.913	4.522	-0.018	0.218	0.103
PO	6	0.411	5.553	-4.193	0.017	0.153	-0.096
ON	7	-0.429	1.761	-5.550	-0.018	0.049	-0.127
NX	43	0.478	1.167	-7.281	0.020	0.032	-0.166
XL	8	-0.341	1.167	3.181	-0.014	0.032	0.073
CD	9	0.475	-2.977	-7.128	0.020	-0.082	-0.163
DE	10	0.475	-6.967	-8.003	0.020	-0.192	-0.183
EF	11	-0.429	-9.310	-4.562	-0.018	-0.257	-0.104
FG	12	0.439	-10.036	-4.562	0.018	-0.277	-0.104
GH	13	-0.440	-10.036	-4.680	-0.018	-0.277	-0.107
HI	14	0.437	-9.314	-4.680	0.018	-0.257	-0.107
IJ	15	-0.490	-6.955	-8.597	-0.020	-0.192	-0.196
JK	16	-0.468	-2.989	-6.994	-0.019	-0.082	-0.160
CB	17	-0.212	-3.387	9.627	-0.011	-0.120	0.183
DT	18	-0.156	-4.845	7.446	-0.008	-0.172	0.141
ES	19	0.000	-3.201	0.000	0.000	-0.233	0.000
FR	20	0.000	-1.632	0.000	0.000	-0.119	0.000
GQ	21	0.000	-0.758	0.000	0.000	-0.055	0.000
HP	22	0.000	-1.638	0.000	0.000	-0.119	0.000
IO	23	0.000	-3.195	0.000	0.000	-0.232	0.000
JN	24	0.174	-4.831	-8.004	0.009	-0.172	-0.152
KL	25	0.210	-3.395	-9.570	0.011	-0.121	-0.181
CT	26	0.000	4.016	0.000	0.000	0.071	0.000
DS	27	-0.008	5.560	0.901	0.000	0.099	0.009
ER	28	0.000	3.403	0.000	0.000	0.094	0.000
FQ	29	0.000	1.054	0.000	0.000	0.077	0.000
HQ	30	0.000	1.048	0.000	0.000	0.076	0.000
IP	31	0.000	3.427	0.000	0.000	0.095	0.000
JO	32	0.002	5.505	0.240	0.000	0.098	0.002
KN	33	0.000	4.037	0.000	0.000	0.072	0.000
A'U	38	-1.401	-6.548	-88.844	-0.022	-0.068	-0.496
UB	36	0.959	-3.730	-64.511	0.015	-0.039	-0.360
UW	34	0.324	-3.663	-24.332	0.009	-0.065	-0.231
MV	39	1.401	-6.547	88.574	0.022	-0.068	0.494
VL	37	-0.958	-3.735	64.399	-0.015	-0.039	0.359
VX	35	-0.320	-3.656	24.175	-0.009	-0.065	0.229

Table G3: Structural Analysis of Area B, Building 8, CCAD

Reaction and Stresses Due to Live Loads							
Member		Shear (kip)	Axial (kip)	Moment (kip-in)	fv	Stress (ksi)	
ID,	#					fc,t	fb
BW	1	0.419	1.432	3.902	0.017	0.039	0.089
WT	42	-0.582	1.432	-8.796	-0.024	0.039	-0.201
TS	2	0.501	2.116	-5.699	0.021	0.058	-0.130
SR	3	0.509	6.802	-5.651	0.021	0.188	-0.129
RQ	4	0.531	9.666	5.608	0.022	0.267	0.128
QP	5	-0.533	9.671	5.527	-0.022	0.267	0.126
PO	6	0.503	6.788	-5.124	0.021	0.187	-0.117
ON	7	-0.525	2.153	-6.784	-0.022	0.059	-0.155
NX	43	0.584	1.427	-8.900	0.024	0.039	-0.203
XL	8	-0.416	1.427	3.888	-0.017	0.039	0.089
CD	9	0.580	-3.639	-8.711	0.024	-0.100	-0.199
DE	10	0.580	-8.516	-9.781	0.024	-0.235	-0.223
EF	11	-0.524	-11.379	-5.576	-0.022	-0.314	-0.127
FG	12	0.536	-12.266	-5.576	0.022	-0.338	-0.127
GH	13	-0.538	-12.266	-5.719	-0.022	-0.338	-0.131
HI	14	0.535	-11.384	-5.719	0.022	-0.314	-0.131
IJ	15	-0.598	-8.501	-10.507	-0.025	-0.234	-0.240
JK	16	-0.572	-3.653	-8.548	-0.024	-0.101	-0.195
CB	17	-0.259	-4.140	11.767	-0.014	-0.147	0.223
DT	18	-0.191	-5.922	9.101	-0.010	-0.211	0.173
ES	19	0.000	-3.912	0.000	0.000	-0.285	0.000
FR	20	0.000	-1.995	0.000	0.000	-0.145	0.000
GQ	21	0.000	-0.926	0.000	0.000	-0.067	0.000
HP	22	0.000	-2.001	0.000	0.000	-0.146	0.000
IO	23	0.000	-3.905	0.000	0.000	-0.284	0.000
JN	24	0.213	-5.905	-9.782	0.011	-0.210	-0.186
KL	25	0.256	-4.150	-11.696	0.014	-0.148	-0.222
CT	26	0.000	4.908	0.000	0.000	0.087	0.000
DS	27	-0.010	6.795	1.101	0.000	0.121	0.010
ER	28	0.000	4.159	0.000	0.000	0.115	0.000
FQ	29	0.000	1.288	0.000	0.000	0.094	0.000
HQ	30	0.000	1.281	0.000	0.000	0.093	0.000
IP	31	0.000	4.188	0.000	0.000	0.116	0.000
JO	32	0.003	6.729	0.293	0.000	0.120	0.003
KN	33	0.000	4.934	0.000	0.000	0.088	0.000
A'U	38	-1.713	-8.003	-108.587	-0.027	-0.084	-0.606
UB	36	1.173	-4.558	-78.847	0.018	-0.048	-0.440
UW	34	0.395	-4.476	-29.740	0.011	-0.080	-0.282
M'V	39	1.713	-8.002	108.257	0.027	-0.084	0.604
VL	37	-1.170	-4.566	78.709	-0.018	-0.048	0.439
VX	35	-0.391	-4.469	29.548	-0.010	-0.079	0.280

Table G4: Structural Analysis of Area B, Building 8, CCAD
Reaction and Stresses Due to Point Loads

Member		Shear (kip)	Axial (kip)	Moment (kip-in)	fv	Stress (ksi)	
ID,	#					fc,t	fb
BW	1	-0.036	0.678	1.539	-0.001	0.019	0.035
WT	42	-0.036	0.678	-1.132	-0.001	0.019	-0.026
TS	2	0.001	1.019	0.339	0.000	0.028	0.008
SR	3	0.005	3.367	0.693	0.000	0.093	0.016
RQ	4	0.011	4.796	1.536	0.000	0.132	0.035
QP	5	-0.012	4.798	1.536	0.000	0.132	0.035
PO	6	0.001	3.359	0.699	0.000	0.093	0.016
ON	7	-0.013	1.038	0.699	-0.001	0.029	0.016
NX	43	0.037	0.676	-1.183	0.002	0.019	-0.027
XL	8	0.037	0.676	1.563	0.002	0.019	0.036
CD	9	0.055	-1.766	-2.089	0.002	-0.049	-0.048
DE	10	0.035	-4.206	-1.464	0.001	-0.116	-0.033
EF	11	-0.010	-5.636	1.146	0.000	-0.155	0.026
FG	12	0.013	-6.087	1.414	0.001	-0.168	0.032
GH	13	-0.014	-6.087	1.414	-0.001	-0.168	0.032
HI	14	0.015	-5.638	1.455	0.001	-0.155	0.033
IJ	15	-0.044	-4.199	-1.823	-0.002	-0.116	-0.042
JK	16	-0.051	-1.774	-2.006	-0.002	-0.049	-0.046
CB	17	-0.081	-1.830	4.324	-0.004	-0.065	0.082
DT	18	-0.093	-2.444	4.386	-0.005	-0.087	0.083
ES	19	0.000	-1.461	0.000	0.000	-0.106	0.000
FR	20	0.000	-0.499	0.000	0.000	-0.036	0.000
GQ	21	0.000	0.028	0.000	0.000	0.002	0.000
HP	22	0.000	-0.502	0.000	0.000	-0.037	0.000
IO	23	0.000	-1.457	0.000	0.000	-0.106	0.000
JN	24	0.104	-2.436	-4.731	0.006	-0.087	-0.090
KL	25	0.080	-1.835	-4.288	0.004	-0.065	-0.081
CT	26	0.000	2.448	0.000	0.000	0.044	0.000
DS	27	-0.005	3.404	0.578	0.000	0.061	0.005
ER	28	0.000	2.076	0.000	0.000	0.057	0.000
FQ	29	0.000	0.656	0.000	0.000	0.048	0.000
HQ	30	0.000	0.652	0.000	0.000	0.047	0.000
IP	31	0.000	2.090	0.000	0.000	0.058	0.000
JO	32	0.001	3.371	0.162	0.000	0.060	0.002
KN	33	0.000	2.460	0.000	0.000	0.044	0.000
A'U	38	-0.840	-3.500	-53.270	-0.013	-0.037	-0.297
UB	36	0.597	-1.795	-38.907	0.009	-0.019	-0.217
UW	34	0.190	-2.222	-14.363	0.005	-0.039	-0.136
M'V	39	0.840	-3.500	53.105	0.013	-0.037	0.296
VL	37	-0.596	-1.798	38.837	-0.009	-0.019	0.217
VX	35	-0.188	-2.218	14.268	-0.005	-0.039	0.135

Table G5: Structural Analysis of Area B, Building 8, CCAD

Reaction and Stresses Due to Wind Loads

Member		Shear	Axial	Moment	Stress (ksi)		
ID,	#	(kip)	(kip)	(kip-in)	fv	fc,t	fb
BW	1	0.488	-6.610	-5.653	0.020	-0.182	-0.129
WT	42	0.844	-6.610	16.600	0.035	-0.182	0.379
TS	2	0.617	-1.356	7.364	0.026	-0.037	0.168
SR	3	-0.614	-8.160	7.364	-0.025	-0.225	0.168
RQ	4	-0.639	-12.833	-6.465	-0.026	-0.354	-0.148
QP	5	0.626	-15.282	-6.940	0.026	-0.421	-0.158
PO	6	0.605	-13.074	-5.779	0.025	-0.361	-0.132
ON	7	0.619	-8.699	7.075	0.026	-0.240	0.162
NX	43	-0.533	-0.197	4.354	-0.022	-0.005	0.099
XL	8	0.667	-0.197	9.381	0.028	-0.005	0.214
CD	9	0.712	0.280	8.659	0.029	0.008	0.198
DE	10	-0.728	7.341	13.865	-0.030	0.202	0.317
EF	11	0.635	12.015	6.940	0.026	0.331	0.158
FG	12	-0.645	14.310	6.940	-0.027	0.395	0.158
GH	13	0.635	14.310	-6.370	0.026	0.395	-0.145
HI	14	-0.623	14.464	6.249	-0.026	0.399	0.143
IJ	15	0.687	12.256	10.403	0.028	0.338	0.238
JK	16	0.726	7.663	11.320	0.030	0.211	0.258
CB	17	2.413	2.127	-44.651	0.129	0.076	-0.847
DT	18	0.257	8.630	-13.354	0.014	0.307	-0.253
ES	19	0.000	5.959	0.000	0.000	0.433	0.000
FR	20	0.000	3.697	0.000	0.000	0.269	0.000
GQ	21	0.000	1.120	0.000	0.000	0.081	0.000
HP	22	0.000	1.105	0.000	0.000	0.080	0.000
IO	23	0.000	3.407	0.000	0.000	0.248	0.000
JN	24	-0.218	5.754	9.869	-0.012	0.205	0.187
KL	25	-0.307	8.474	12.914	-0.016	0.301	0.245
CT	26	0.000	-2.260	0.000	0.000	-0.040	0.000
DS	27	-0.016	-9.900	1.747	0.000	-0.176	0.017
ER	28	0.000	-6.788	0.000	0.000	-0.187	0.000
FQ	29	0.000	-3.333	0.000	0.000	-0.242	0.000
HQ	30	0.000	0.224	0.000	0.000	0.016	0.000
IP	31	0.000	-3.207	0.000	0.000	-0.088	0.000
JO	32	-0.011	-6.343	-1.198	0.000	-0.113	-0.011
KN	33	0.000	-10.684	0.000	0.000	-0.190	0.000
A'U	38	6.591	10.901	-318.769	0.103	0.114	-1.778
UB	36	-4.197	2.483	212.159	-0.066	0.026	1.183
UW	34	-0.955	10.950	77.422	-0.025	0.195	0.734
M'V	39	0.819	8.299	-78.411	0.013	0.087	-0.437
VL	37	-0.110	9.141	11.801	-0.002	0.096	0.066
VX	35	0.061	-1.253	7.148	0.002	-0.022	0.068

Table G6: Structural Analysis of Area B, Building 8, CCAD									
Actual Total Stresses									
Member		Load Comb.=D.L+L.L+Point L.				Load Comb.=D.L+W.L+Point L.			
ID,	#	fv	ft	fc	fb	fv	ft	fc	fb
BW	1	0.030	0.091		0.197	0.033		-0.131	-0.021
WT	42	-0.045	0.091		-0.391	0.014		-0.131	0.189
TS	2	0.038	0.134		-0.229	0.043	0.038		0.069
SR	3	0.039	0.434		-0.219	-0.008	0.021		0.078
RQ	4	0.040	0.617		0.268	-0.008		-0.004	-0.008
QP	5	-0.041	0.617		0.264	0.007		-0.071	-0.020
PO	6	0.038	0.433		-0.197	0.042		-0.115	-0.212
ON	7	-0.040	0.137		-0.266	0.007		-0.163	0.051
NX	43	0.045	0.090		-0.396	-0.001	0.045		-0.094
XL	8	-0.030	0.090		0.197	0.015	0.045		0.322
CD	9	0.046		-0.231	-0.409	0.051		-0.123	-0.013
DE	10	0.045		-0.543	-0.439	-0.009		-0.106	0.100
EF	11	-0.040		-0.726	-0.205	0.008		-0.081	0.080
FG	12	0.041		-0.783	-0.199	-0.008		-0.050	0.087
GH	13	-0.041		-0.783	-0.205	0.007		-0.050	-0.220
HI	14	0.041		-0.726	-0.204	-0.007		-0.013	0.069
IJ	15	-0.047		-0.542	-0.478	0.006	0.030		0.000
JK	16	-0.045		-0.232	-0.401	0.009	0.080		0.053
CB	17	-0.029		-0.333	0.488	0.113		-0.110	-0.582
DT	18	-0.023		-0.470	0.397	0.000	0.048		-0.029
ES	19	0.000		-0.624	0.000	0.000	0.094		0.000
FR	20	0.000		-0.300	0.000	0.000	0.114		0.000
GQ	21	0.000		-0.120	0.000	0.000	0.028		0.000
HP	22	0.000		-0.301	0.000	0.000		-0.075	0.000
IO	23	0.000		-0.622	0.000	0.000		-0.091	0.000
JN	24	0.026		-0.468	-0.427	0.003		-0.054	-0.054
KL	25	0.029		-0.333	-0.485	-0.001	0.115		-0.018
CT	26	0.000	0.202		0.000	0.000	0.075		0.000
DS	27	-0.001	0.280		0.024	-0.001		-0.017	0.031
ER	28	0.000	0.266		0.000	0.000		-0.036	0.000
FQ	29	0.000	0.218		0.000	0.000		-0.118	0.000
HQ	30	0.000	0.217		0.000	0.000	0.140		0.000
IP	31	0.000	0.268		0.000	0.000	0.064		0.000
JO	32	0.000	0.277		0.007	0.000	0.045		-0.008
KN	33	0.000	0.203		0.000	0.000		-0.074	0.000
A'U	38	-0.062		-0.189	-1.398	0.068	0.009		-2.571
UB	36	0.043		-0.105	-1.017	-0.041		-0.032	0.606
UW	34	0.024		-0.184	-0.649	-0.012	0.090		0.367
M'V	39	0.062		-0.189	1.394	0.048		-0.018	0.353
VL	37	-0.043		-0.106	1.015	-0.026	0.038		0.642
VX	35	-0.024		-0.184	0.645	-0.012		-0.127	0.432

Laboratory Test (ksi)		NDS (ksi), Unfactored	
Fb=	3.195	Fb=	2.100
Fc=	1.880	Fc=	1.750
Fv=	0.159	Fv=	0.090
Ft=	1.355	Ft=	1.100
Density =35 lb/ft ³			

Table G8: Structural Analysis of Area B, Building 8, CCAD

Adjustment Factors from NDS Specifications and Factored Allowables

Member		Load Comb.: D.L+L.L+P.L for : F _b =1.7, F _t =0.9, F _v =0.1, F _c =1.7								(ksi)			
ID,	#	C _d	C _m	C _t	C _f	C _v <1.0	C _f	C _p	C _h	F _b	F _t	F _v	F _c
BW	1	1.25	1	1	1.000	1	1.1	1	1	2.888	1.513	0.113	2.406
WT	42	1.25	1	1	1.000	1	1.1	1	1	2.888	1.513	0.113	2.406
TS	2	1.25	1	1	1.000	1	1.1	1	1	2.888	1.513	0.113	2.406
SR	3	1.25	1	1	1.000	1	1.1	1	1	2.888	1.513	0.113	2.406
RQ	4	1.25	1	1	1.000	1	1.1	1	1	2.888	1.513	0.113	2.406
QP	5	1.25	1	1	1.000	1	1.1	1	1	2.888	1.513	0.113	2.406
PO	6	1.25	1	1	1.000	1	1.1	1	1	2.888	1.513	0.113	2.406
ON	7	1.25	1	1	1.000	1	1.1	1	1	2.888	1.513	0.113	2.406
NX	43	1.25	1	1	1.000	1	1.1	1	1	2.888	1.513	0.113	2.406
XL	8	1.25	1	1	1.000	1	1.1	1	1	2.888	1.513	0.113	2.406
CD	9	1.25	1	1	1.000	1	1.1	1	1	2.888	1.513	0.113	2.406
DE	10	1.25	1	1	1.000	1	1.1	1	1	2.888	1.513	0.113	2.406
EF	11	1.25	1	1	1.000	1	1.1	1	1	2.888	1.513	0.113	2.406
FG	12	1.25	1	1	1.000	1	1.1	1	1	2.888	1.513	0.113	2.406
GH	13	1.25	1	1	1.000	1	1.1	1	1	2.888	1.513	0.113	2.406
HI	14	1.25	1	1	1.000	1	1.1	1	1	2.888	1.513	0.113	2.406
IJ	15	1.25	1	1	1.000	1	1.1	1	1	2.888	1.513	0.113	2.406
JK	16	1.25	1	1	1.000	1	1.1	1	1	2.888	1.513	0.113	2.406
CB	17	1.25	1	1	1.000	1	1.1	1	1	2.888	1.513	0.113	2.252
DT	18	1.25	1	1	1.000	1	1.1	1	1	2.888	1.513	0.113	2.252
ES	19	1.25	1	1	1.000	1	1.1	1	1	2.888	1.513	0.113	2.252
FR	20	1.25	1	1	1.000	1	1.1	1	1	2.888	1.513	0.113	2.252
GQ	21	1.25	1	1	1.000	1	1.1	1	1	2.888	1.513	0.113	2.252
HP	22	1.25	1	1	1.000	1	1.1	1	1	2.888	1.513	0.113	2.252
IO	23	1.25	1	1	1.000	1	1.1	1	1	2.888	1.513	0.113	2.252
JN	24	1.25	1	1	1.000	1	1.1	1	1	2.888	1.513	0.113	2.252
KL	25	1.25	1	1	1.000	1	1.1	1	1	2.888	1.513	0.113	2.252
GT	26	1.25	1	1	1.000	1	1.1	1	1	2.888	1.513	0.113	2.406
DS	27	1.25	1	1	1.000	1	1.1	1	1	2.888	1.513	0.113	2.406
ER	28	1.25	1	1	1.000	1	1.1	1	1	2.888	1.513	0.113	2.406
FQ	29	1.25	1	1	1.000	1	1.1	1	1	2.888	1.513	0.113	2.406
HQ	30	1.25	1	1	1.000	1	1.1	1	1	2.888	1.513	0.113	2.406
IP	31	1.25	1	1	1.000	1	1.1	1	1	2.888	1.513	0.113	2.406
JO	32	1.25	1	1	1.000	1	1.1	1	1	2.888	1.513	0.113	2.406
KN	33	1.25	1	1	1.000	1	1.1	1	1	2.888	1.513	0.113	2.406
A'U	38	1.25	1	1	1.000	1	1.1	1	1	2.888	1.513	0.113	1.213
UB	36	1.25	1	1	1.000	1	1.1	1	1	2.888	1.513	0.113	1.213
UW	34	1.25	1	1	1.000	1	1.1	1	1	2.888	1.513	0.113	2.406
M'V	39	1.25	1	1	1.000	1	1.1	1	1	2.888	1.513	0.113	1.213
VL	37	1.25	1	1	1.000	1	1.1	1	1	2.888	1.513	0.113	1.213
VX	35	1.25	1	1	1.000	1	1.1	1	1	2.888	1.513	0.113	2.406

C_m=1.0 due to occupancy Live Load.

When C_v is determined, some vales are used conventionally.

C_h=1.0 for assuming splits at all members.

Table G9: Structural Analysis of Area B, Building 8, CCAD													
Adjustment Factors from NDS Specifications and Factored Allowables													
Member		Load Comb.: D.L+W.L+P.L for Fb=1.7, Ft=0.9, Fv=0.1, Fc=1.7									(ksi)		
ID,	#	Cd	Cm	Ct	Cfu	Cv<1.0	Cf	Cp	Ch	F'b	F't	F'v	F'c
BW	1	1.60	1	1	1	1	1.1	1.000	1	3.866	1.841	0.144	3.080
WT	42	1.60	1	1	1	1	1.1	1.000	1	3.866	1.841	0.144	3.080
TS	2	1.60	1	1	1	1	1.1	1.000	1	3.866	1.841	0.144	3.080
SR	3	1.60	1	1	1	1	1.1	1.000	1	3.866	1.841	0.144	3.080
RQ	4	1.60	1	1	1	1	1.1	1.000	1	3.866	1.841	0.144	3.080
QP	5	1.60	1	1	1	1	1.1	1.000	1	3.866	1.841	0.144	3.080
PO	6	1.60	1	1	1	1	1.1	1.000	1	3.866	1.841	0.144	3.080
ON	7	1.60	1	1	1	1	1.1	1.000	1	3.866	1.841	0.144	3.080
NX	43	1.60	1	1	1	1	1.1	1.000	1	3.866	1.841	0.144	3.080
XL	8	1.60	1	1	1	1	1.1	1.000	1	3.866	1.841	0.144	3.080
CD	9	1.60	1	1	1	1	1.1	1.000	1	3.866	1.841	0.144	3.080
DE	10	1.60	1	1	1	1	1.1	1.000	1	3.866	1.841	0.144	3.080
EF	11	1.60	1	1	1	1	1.1	1.000	1	3.866	1.841	0.144	3.080
FG	12	1.60	1	1	1	1	1.1	1.000	1	3.866	1.841	0.144	3.080
GH	13	1.60	1	1	1	1	1.1	1.000	1	3.866	1.841	0.144	3.080
HI	14	1.60	1	1	1	1	1.1	1.000	1	3.866	1.841	0.144	3.080
IJ	15	1.60	1	1	1	1	1.1	1.000	1	3.866	1.841	0.144	3.080
JK	16	1.60	1	1	1	1	1.1	1.000	1	3.866	1.841	0.144	3.080
CB	17	1.60	1	1	1	1	1.1	0.936	1	3.696	1.760	0.144	2.883
DT	18	1.60	1	1	1	1	1.1	0.936	1	3.696	1.760	0.144	2.883
ES	19	1.60	1	1	1	1	1.1	0.936	1	3.992	1.901	0.144	2.883
FR	20	1.60	1	1	1	1	1.1	0.936	1	3.992	1.901	0.144	2.883
GQ	21	1.60	1	1	1	1	1.1	0.936	1	3.992	1.901	0.144	2.883
HP	22	1.60	1	1	1	1	1.1	0.936	1	3.992	1.901	0.144	2.883
IO	23	1.60	1	1	1	1	1.1	0.936	1	3.992	1.901	0.144	2.883
JN	24	1.60	1	1	1	1	1.1	0.936	1	3.696	1.760	0.144	2.883
KL	25	1.60	1	1	1	1	1.1	0.936	1	3.696	1.760	0.144	2.883
CT	26	1.60	1	1	1	1	1.1	1.000	1	3.696	1.760	0.144	3.080
DS	27	1.60	1	1	1	1	1.1	1.000	1	3.696	1.760	0.144	3.080
ER	28	1.60	1	1	1	1	1.1	1.000	1	3.866	1.841	0.144	3.080
FQ	29	1.60	1	1	1	1	1.1	1.000	1	3.992	1.901	0.144	3.080
HQ	30	1.60	1	1	1	1	1.1	1.000	1	3.992	1.901	0.144	3.080
IP	31	1.60	1	1	1	1	1.1	1.000	1	3.866	1.841	0.144	3.080
JO	32	1.60	1	1	1	1	1.1	1.000	1	3.696	1.760	0.144	3.080
KN	33	1.60	1	1	1	1	1.1	1.000	1	3.696	1.760	0.144	3.080
A'U	38	1.60	1	1	1	1	1.1	0.504	1	3.696	1.760	0.144	1.552
UB	36	1.60	1	1	1	1	1.1	0.504	1	3.696	1.760	0.144	1.552
UW	34	1.60	1	1	1	1	1.1	1.000	1	3.696	1.760	0.144	3.080
M'V	39	1.60	1	1	1	1	1.1	0.504	1	3.696	1.760	0.144	1.552
VL	37	1.60	1	1	1	1	1.1	0.504	1	3.696	1.760	0.144	1.552
VX	35	1.60	1	1	1	1	1.1	1.000	1	3.696	1.760	0.144	3.080

Cd=1.6 due to Wind Load
 When Cv is determined, some vales are used conventionally.
 Ch=1.0 for assuming splits at all members.

Table G10: Structural Analysis of Area B, Building 8, CCAD

Stress Interaction Per NDS Allowables

Member		Load Comb.:D.L+L.L+Point L.			Load Comb.:D.L+W.L+Point L.		
ID,	#	I (b,t)*	I (b,t) **	I (b,c) ***	I (b,t)*	I (b,t) **	I (b,c) ***
BW	1	0.128	0.037				0.007
WT	42	0.195	0.104				0.053
TS	2	0.168	0.033		0.039	0.008	
SR	3	0.363	0.075		0.032	0.015	
RQ	4	0.501	0.121				0.002
QP	5	0.500	0.122				0.006
PO	6	0.354	0.082				0.058
ON	7	0.182	0.045				0.017
NX	43	0.197	0.106		0.049	0.013	
XL	8	0.128	0.037		0.108	0.072	
CD	9			0.166			0.005
DE	10			0.247			0.028
EF	11			0.193			0.022
FG	12			0.208			0.023
GH	13			0.211			0.058
HI	14			0.192			0.018
IJ	15			0.264	0.017	0.008	
JK	16			0.163	0.057	0.007	
CB	17			0.220			0.165
DT	18			0.217	0.035	0.005	
ES	19			0.077	0.050	0.024	
FR	20			0.018	0.060	0.029	
GQ	21			0.003	0.015	0.007	
HP	22			0.018			0.001
IO	23			0.076			0.001
JN	24			0.230			0.015
KL	25			0.219	0.070	0.026	
CT	26	0.134	0.070		0.042	0.020	
DS	27	0.194	0.089				0.008
ER	28	0.176	0.092				0.000
FQ	29	0.144	0.076				0.001
HQ	30	0.143	0.075		0.074	0.035	
IP	31	0.177	0.093		0.035	0.016	
JO	32	0.186	0.094		0.028	0.010	
KN	33	0.134	0.070				0.001
AU	38			0.598	0.701	0.693	
UB	36			0.393			0.168
UW	34			0.249	0.151	0.075	
MV	39			0.596			0.097
VL	37			0.393	0.195	0.163	
VX	35			0.248			0.124

*: $f_t/F_t + f_b/F_b < 1.0$

** : $(f_b - f_t)/F_b < 1.0$

***: $(f_c/F_c)^2 + f_b/(F_b(1 - (f_c/F_c))) < 1.0$

Table G11: Structural Analysis of Area B, Building 8, CCAD

Stress Interaction Based on Lab. Test Allowables							
Member		Load Comb.:D.L+L.L+Point L.			Load Comb.:D.L+W.L+Point L.		
ID,	#	I (b,t)*	I (b,t)**	I (b,c)***	I (b,t)*	I (b,t)**	I (b,c)***
BW	1	0.128	0.033				0.012
WT	42	0.189	0.094				0.068
TS	2	0.171	0.030		0.050	0.010	
SR	3	0.389	0.067		0.040	0.018	
RQ	4	0.539	0.109				0.002
QP	5	0.538	0.110				0.008
PO	6	0.381	0.074				0.074
ON	7	0.184	0.040				0.025
NX	43	0.191	0.096		0.063	0.015	
XL	8	0.128	0.033		0.134	0.087	
CD	9			0.161			0.009
DE	10			0.277			0.036
EF	11			0.254			0.028
FG	12			0.280			0.029
GH	13			0.283			0.071
HI	14			0.253			0.022
IJ	15			0.293	0.023	0.009	
JK	16			0.158	0.076	0.008	
CB	17			0.217		0.182	
DT	18			0.228	0.044	0.006	
ES	19			0.110	0.070	0.030	
FR	20			0.025	0.084	0.036	
GQ	21			0.004	0.021	0.009	
HP	22			0.026			0.002
IO	23			0.110			0.002
JN	24			0.240			0.018
KL	25			0.216	0.091	0.030	
CT	26	0.149	0.063		0.055	0.023	
DS	27	0.214	0.080				0.010
ER	28	0.196	0.083				0.000
FQ	29	0.161	0.068				0.004
HQ	30	0.160	0.068		0.103	0.044	
IP	31	0.198	0.084		0.047	0.020	
JO	32	0.207	0.085		0.036	0.012	
KN	33	0.150	0.064				0.002
A'U	38			0.497	0.811	0.802	
UB	36			0.340			0.193
UW	34			0.235	0.181	0.087	
M'V	39			0.495			0.112
VL	37			0.340	0.229	0.189	
VX	35			0.233			0.150

*: $f_t/F_t + f_b/F_b < 1.0$ **: $(f_b - f_t)/F_b < 1.0$ ***: $(f_c/F_c)^2 + f_b/(F_b(1 - (f_c/F_c))) < 1.0$

Table G12: Connection Evaluation in Area B

Load Combination=D.L+L.L+P.L

Joint Type	I.D	Position of Ring	Angle (Deg.)	Angle (Rad.)	# of Bolts	P	Q	CD	Cm	Ct	Cg	Cdelta	Cd	Cst	P'	Q'	Sina	Cosa	n'	N'(n*#)	Axial Load	Result Load	Half of Result	Interaction
J1	KL	in	46	0.803	2	6.14	4.27	1.25	1	1	0.502	1	1.18	1	4.55	2.68	0.719	0.695	3.34	6.68	-9.4			0.093
	JK	out	0	0.000	2	6.14	4.27	1.25	1	1	0.502	1	1.18	1	4.55	2.68	0.000	1.000	4.55	9.09	-8.4			0.068
	NK	out	44	0.768	2	6.14	4.27	1.25	1	1	0.502	1	1.18	1	4.55	2.68	0.695	0.719	3.40	6.80	11.4			0.091
	NK	in	0	0.000	2	6.14	4.27	1.25	1	1	0.502	1	1.18	1	4.55	2.68	0.000	1.000	4.55	9.09	11.4	1.24	0.62	0.068
J2	NL	out	90	1.571	2	6.14	4.27	1.25	1	1	0.502	1	1.18	1	4.55	2.68	1.000	0.000	2.68	5.36	3.27			0.928
	KL	in	0	0.000	2	6.14	4.27	1.25	1	1	0.502	1	1.18	1	4.55	2.68	0.000	1.000	4.55	9.09	-9.4	9.95	4.975	0.547
J3	QP	out	44	0.768	1	6.14	4.27	1.25	1	1	0.502	1	1.18	1	4.55	2.68	0.695	0.719	3.40	3.40	22.3			0.250
	QG	in	0	0.000	1	6.14	4.27	1.25	1	1	0.502	1	1.18	1	4.55	2.68	0.000	1.000	4.55	4.55	-1.7			0.187
	QH	in	44	0.768	1	6.14	4.27	1.25	1	1	0.502	1	1.18	1	4.55	2.68	0.695	0.719	3.40	3.40	2.98			0.250
	QH	out	0	0.000	1	6.14	4.27	1.25	1	1	0.502	1	1.18	1	4.55	2.68	0.000	1.000	4.55	4.55	2.98	1.7	0.85	0.187
J4	GQ	in	90	1.571	1	6.14	4.27	1.25	1	1	0.502	1	1.18	1	4.55	2.68	1.000	0.000	2.68	2.68	-1.7			0.317
	GH	out	0	0.000	1	6.14	4.27	1.25	1	1	0.502	1	1.18	1	4.55	2.68	0.000	1.000	4.55	4.55	-28	1.7	0.85	0.187

Load Combination=D.L+W.L+P.L

Joint Type	I.D	Position of Ring	Angle (Deg.)	Angle (Rad.)	# of Bolts	P	Q	CD	Cm	Ct	Cg	Cdelta	Cd	Cst	P'	Q'	Sina	Cosa	n'	N'(n*#)	Axial Load	Result Load	Half of Result	Interaction
J1	KL	in	46	0.803	2	6.14	4.27	1.60	1	1	0.502	1	1.18	1	5.82	3.43	0.719	0.695	4.28	8.55	3.24			0.021
	JK	out	0	0.000	2	6.14	4.27	1.60	1	1	0.502	1	1.18	1	5.82	3.43	0.000	1.000	5.82	11.64	2.9			0.016
	NK	out	44	0.768	2	6.14	4.27	1.60	1	1	0.502	1	1.18	1	5.82	3.43	0.695	0.719	4.36	8.71	-4.2			0.021
	NK	in	0	0.000	2	6.14	4.27	1.60	1	1	0.502	1	1.18	1	5.82	3.43	0.000	1.000	5.82	11.64	-4.2	0.366	0.183	0.016
J2	NL	out	90	1.571	2	6.14	4.27	1.60	1	1	0.502	1	1.18	1	5.82	3.43	1.000	0.000	3.43	6.86	1.65			0.265
	KL	in	0	0.000	2	6.14	4.27	1.60	1	1	0.502	1	1.18	1	5.82	3.43	0.000	1.000	5.82	11.64	3.24	3.63	1.815	0.156
J3	QP	out	44	0.768	1	6.14	4.27	1.60	1	1	0.502	1	1.18	1	5.82	3.43	0.695	0.719	4.36	4.36	-1.6			0.189
	QG	in	0	0.000	1	6.14	4.27	1.60	1	1	0.502	1	1.18	1	5.82	3.43	0.000	1.000	5.82	5.82	0.39			0.142
	QH	in	44	0.768	1	6.14	4.27	1.60	1	1	0.502	1	1.18	1	5.82	3.43	0.695	0.719	4.36	4.36	1.95			0.189
	QH	out	0	0.000	1	6.14	4.27	1.60	1	1	0.502	1	1.18	1	5.82	3.43	0.000	1.000	5.82	5.82	1.95	1.65	0.825	0.142
J4	GQ	in	90	1.571	1	6.14	4.27	1.60	1	1	0.502	1	1.18	1	5.82	3.43	1.000	0.000	3.43	3.43	0.39			0.053
	GH	out	0	0.000	1	6.14	4.27	1.60	1	1	0.502	1	1.18	1	5.82	3.43	0.000	1.000	5.82	5.82	1.95	0.39	0.195	0.031

Appendix H: Analytical Results for Members and Joints in Areas C and D

Table H1: Structural Analysis of Area D, Building 8, CCAD

Member		Section Properties		
ID,	#	Area (in ²)	Inertia (in ⁴)	Centroid (In)
BC	21	28.1	297	5.625
CD	11	36.3	159	3.625
DE	12	36.3	159	3.625
EF	13	36.3	159	3.625
FG	14	36.3	159	3.625
GH	15	36.3	159	3.625
HI	16	36.3	159	3.625
IJ	17	36.3	159	3.625
JK	18	36.3	159	3.625
KL	19	36.3	159	3.625
LM	20	36.3	159	3.625
MN	31	28.1	297	5.625
NX'	10	36.3	159	3.625
OP	9	36.3	159	3.625
PQ	8	36.3	159	3.625
QR	7	36.3	159	3.625
RS	6	36.3	159	3.625
ST	5	36.3	159	3.625
TU	4	36.3	159	3.625
UV	3	36.3	159	3.625
VW	2	36.3	159	3.625
XB	1	36.3	159	3.625
CW	32	56.3	593	5.625
DW	22	28.1	297	5.625
DV	33	56.3	593	5.625
VE	23	28.1	297	5.625
EU	34	36.3	159	3.625
UF	24	13.8	35	2.750
FT	35	27.5	69	2.750
TG	25	13.8	35	2.750
GS	36	13.8	35	2.750
SH	26	13.8	35	2.750
SI	37	13.8	35	2.750
IR	27	13.8	35	2.750
RJ	38	27.5	69	2.750
JQ	28	13.8	35	2.750
QK	39	36.3	159	3.625
KP	29	28.1	297	5.625
PL	40	28.1	297	5.625
LO	30	28.1	297	5.625
OM	41	56.3	593	5.625
XW	42	36.3	159	5.625
XY	43	56.3	593	5.625
BY	44	120.0	1440	5.625
YZ	45	120.0	1440	5.625
OX'	47	120.0	1440	5.625
X'Y'	48	56.3	593	5.625
NY'	49	120.0	1440	5.625
YZ''	50	120.0	1440	5.625

Table H2: Structural Analysis of Area D, Building 8, CCAD

Reaction and Stresses Due to Dead Loads

Member ID, #	Shear (kip)	Axial (kip)	Moment (kip-in)	Stress (ksi)		
				fv	fc,t	fb
BC 21	-0.074	-3.888	3.073	-0.004	-0.138	0.058
CD 11	0.502	-3.141	-8.333	0.021	-0.087	-0.190
DE 12	0.383	-7.144	-5.597	0.016	-0.197	-0.128
EF 13	0.339	-9.871	3.030	0.014	-0.272	0.069
FG 14	-0.333	-11.512	3.214	-0.014	-0.317	0.073
GH 15	0.351	-12.016	3.774	0.015	-0.331	0.086
HI 16	-0.350	-12.016	3.804	-0.014	-0.331	0.087
IJ 17	-0.328	-11.511	3.097	-0.014	-0.317	0.071
JK 18	0.341	-9.881	3.501	0.014	-0.272	0.080
KL 19	-0.430	-7.102	-7.184	-0.018	-0.196	-0.164
LM 20	-0.486	-3.170	-8.087	-0.020	-0.087	-0.185
MN 31	0.069	-3.903	-2.927	0.004	-0.139	-0.056
NX' 10	0.558	1.711	-10.139	0.023	0.047	-0.231
OP 9	-0.432	2.538	-5.071	-0.018	0.070	-0.116
PQ 8	-0.348	6.257	-3.281	-0.014	0.173	-0.075
QR 7	-0.334	8.978	3.089	-0.014	0.248	0.071
RS 6	-0.353	10.609	4.093	-0.015	0.293	0.093
ST 5	0.354	10.609	4.066	0.015	0.293	0.093
TU 4	0.330	8.969	3.168	0.014	0.247	0.072
UV 3	0.366	6.283	-4.127	0.015	0.173	-0.094
VW 2	0.362	2.472	3.204	0.015	0.068	0.073
XB 1	-0.556	1.725	-10.098	-0.023	0.048	-0.231
CW 32	-0.188	4.565	-11.560	-0.005	0.081	-0.110
DW 22	-0.233	-5.029	10.453	-0.012	-0.179	0.198
DV 33	-0.020	5.865	1.377	-0.001	0.104	0.013
VE 23	-0.041	-3.835	2.954	-0.002	-0.136	0.056
EU 34	0.000	4.196	0.000	0.000	0.116	0.000
UF 24	0.000	-2.605	0.000	0.000	-0.189	0.000
FT 35	0.000	2.562	0.000	0.000	0.093	0.000
TG 25	0.000	-1.289	0.000	0.000	-0.094	0.000
GS 36	0.000	0.788	0.000	0.000	0.057	0.000
SH 26	0.000	-0.608	0.000	0.000	-0.044	0.000
SI 37	0.000	0.789	0.000	0.000	0.057	0.000
IR 27	0.000	-1.283	0.000	0.000	-0.093	0.000
RJ 38	0.000	2.547	0.000	0.000	0.093	0.000
JQ 28	0.000	-2.625	0.000	0.000	-0.191	0.000
QK 39	0.000	4.251	0.000	0.000	0.117	0.000
KP 29	0.057	-3.804	-4.131	0.003	-0.135	-0.078
PL 40	0.012	5.705	0.715	0.001	0.203	0.014
LO 30	0.271	-4.974	-11.638	0.014	-0.177	-0.221
OM 41	0.195	4.611	-12.188	0.005	0.082	-0.116
XW 42	2.200	-0.828	19.199	0.091	-0.023	0.680
XY 43	0.144	-3.754	-16.693	0.004	-0.067	-0.158
BY 44	1.651	-3.792	-62.917	0.021	-0.032	-0.246
YZ 45	-0.902	-6.548	-79.610	-0.011	-0.055	-0.311
OX' 47	-1.989	-0.834	18.756	-0.025	-0.007	0.073
X'Y' 48	-0.140	-3.738	16.562	-0.004	-0.066	0.157
NY' 49	-1.642	-3.805	62.684	-0.021	-0.032	0.245
Y'Z'' 50	0.902	-6.547	79.247	0.011	-0.055	0.310

Table H3: Structural Analysis of Area D, Building 8, CCAD
Reaction and Stresses Due to Live Loads

Member ID,	#	Shear (kip)	Axial (kip)	Moment (kip-in)	Stress (ksi)		
					fv	fc,t	fb
BC	21	-0.091	-4.752	3.755	-0.005	-0.169	0.071
CD	11	0.613	-3.839	-10.185	0.025	-0.106	-0.233
DE	12	0.468	-8.732	-6.841	0.019	-0.241	-0.156
EF	13	0.415	-12.065	3.704	0.017	-0.333	0.085
FG	14	-0.407	-14.070	3.928	-0.017	-0.388	0.090
GH	15	0.429	-14.686	4.613	0.018	-0.405	0.105
HI	16	-0.428	-14.686	4.650	-0.018	-0.405	0.106
IJ	17	-0.400	-14.069	3.785	-0.017	-0.388	0.086
JK	18	0.416	-12.076	4.278	0.017	-0.333	0.098
KL	19	-0.526	-8.680	-8.780	-0.022	-0.239	-0.200
LM	20	-0.593	-3.874	-9.885	-0.025	-0.107	-0.226
MN	31	0.084	-4.770	-3.577	0.004	-0.170	-0.068
NX'	10	0.682	2.091	-12.392	0.028	0.058	-0.283
OP	9	-0.529	3.103	-6.198	-0.022	0.086	-0.142
PQ	8	-0.426	7.647	-4.010	-0.018	0.211	-0.092
QR	7	-0.409	10.974	3.775	-0.017	0.303	0.086
RS	6	-0.431	12.967	5.003	-0.018	0.358	0.114
ST	5	0.433	12.967	4.970	0.018	0.358	0.113
TU	4	0.403	10.962	3.871	0.017	0.302	0.088
UV	3	0.447	7.679	-5.044	0.018	0.212	-0.115
VW	2	0.443	3.021	3.916	0.018	0.083	0.089
XB	1	-0.680	2.108	-12.341	-0.028	0.058	-0.282
CW	32	-0.230	5.579	-14.128	-0.006	0.099	-0.134
DW	22	-0.285	-6.147	12.775	-0.015	-0.219	0.242
DV	33	-0.024	7.168	1.683	-0.001	0.127	0.016
VE	23	-0.050	-4.687	3.611	-0.003	-0.167	0.068
EU	34	0.000	5.129	0.000	0.000	0.141	0.000
UF	24	0.000	-3.184	0.000	0.000	-0.232	0.000
FT	35	0.000	3.132	0.000	0.000	0.114	0.000
TG	25	0.000	-1.576	0.000	0.000	-0.115	0.000
GS	36	0.000	0.963	0.000	0.000	0.070	0.000
SH	26	0.000	-0.744	0.000	0.000	-0.054	0.000
SI	37	0.000	0.964	0.000	0.000	0.070	0.000
IR	27	0.000	-1.568	0.000	0.000	-0.114	0.000
RJ	38	0.000	3.112	0.000	0.000	0.113	0.000
JQ	28	0.000	-3.208	0.000	0.000	-0.233	0.000
QK	39	0.000	5.196	0.000	0.000	0.143	0.000
KP	29	0.070	-4.650	-5.048	0.004	-0.165	-0.096
PL	40	0.014	6.972	0.874	0.001	0.248	0.017
LO	30	0.331	-6.080	-14.224	0.018	-0.216	-0.270
OM	41	0.238	5.635	-14.897	0.006	0.100	-0.141
XW	42	2.688	-1.012	23.465	0.111	-0.028	0.831
XY	43	0.175	-4.588	-20.403	0.005	-0.082	-0.193
BY	44	2.017	-4.635	-76.898	0.025	-0.039	-0.300
YZ	45	-1.103	-8.003	-97.302	-0.014	-0.067	-0.380
OX'	47	-2.432	-1.019	22.923	-0.030	-0.008	0.090
X'Y	48	-0.171	-4.568	20.243	-0.005	-0.081	0.192
NY'	49	-2.007	-4.651	76.614	-0.025	-0.039	0.299
Y'Z''	50	1.103	-8.002	96.857	0.014	-0.067	0.378

Table H4: Structural Analysis of Area D, Building 8, CCAD
Reaction and Stresses Due to Point Loads

Member ID, #	Shear (kip)	Axial (kip)	Moment (kip-in)	Stress (ksi)		
				fv	fc,t	fb
BC 21	-0.030	-2.742	1.438	-0.002	-0.097	0.027
CD 11	0.135	-2.360	4.041	0.006	-0.065	0.092
DE 12	0.042	-5.416	-1.649	0.002	-0.149	-0.038
EF 13	0.008	-7.499	1.297	0.000	-0.207	0.030
FG 14	-0.002	-8.750	1.297	0.000	-0.241	0.030
GH 15	0.011	-9.147	1.796	0.000	-0.252	0.041
HI 16	-0.010	-9.147	1.796	0.000	-0.252	0.041
IJ 17	-0.002	-8.750	1.200	0.000	-0.241	0.027
JK 18	0.012	-7.506	1.791	0.000	-0.207	0.041
KL 19	-0.078	-5.384	-2.872	-0.003	-0.148	-0.066
LM 20	-0.122	-2.382	-3.850	-0.005	-0.066	-0.088
MN 31	0.025	-2.753	-1.326	0.001	-0.098	-0.025
NX' 10	0.266	1.282	-7.003	0.011	0.035	-0.160
OP 9	-0.074	1.913	3.247	-0.003	0.053	0.074
PQ 8	-0.016	4.754	1.003	-0.001	0.131	0.023
QR 7	-0.005	6.834	1.323	0.000	0.188	0.030
RS 6	-0.013	8.077	2.084	-0.001	0.223	0.048
ST 5	0.013	8.077	2.084	0.001	0.223	0.048
TU 4	0.002	6.827	1.279	0.000	0.188	0.029
UV 3	0.029	4.773	1.166	0.001	0.132	0.027
VW 2	0.020	1.862	1.745	0.001	0.051	0.040
XB 1	-0.265	1.292	-6.971	-0.011	0.036	-0.159
CW 32	-0.121	3.495	-8.031	-0.003	0.062	-0.076
DW 22	-0.175	-3.346	7.836	-0.009	-0.119	0.149
DV 33	-0.012	4.486	0.928	0.000	0.080	0.009
VE 23	-0.030	-2.430	2.161	-0.002	-0.086	0.041
EU 34	0.000	3.207	0.000	0.000	0.088	0.000
UF 24	0.000	-1.491	0.000	0.000	-0.108	0.000
FT 35	0.000	1.954	0.000	0.000	0.071	0.000
TG 25	0.000	-0.490	0.000	0.000	-0.036	0.000
GS 36	0.000	0.620	0.000	0.000	0.045	0.000
SH 26	0.000	0.021	0.000	0.000	0.002	0.000
SI 37	0.000	0.621	0.000	0.000	0.045	0.000
IR 27	0.000	-0.485	0.000	0.000	-0.035	0.000
RJ 38	0.000	1.942	0.000	0.000	0.071	0.000
JQ 28	0.000	-1.506	0.000	0.000	-0.110	0.000
QK 39	0.000	3.249	0.000	0.000	0.090	0.000
KP 29	0.042	-2.406	-3.035	0.002	-0.086	-0.058
PL 40	0.007	4.364	0.456	0.000	0.155	0.009
LO 30	0.204	-3.303	-8.739	0.011	-0.117	-0.166
OM 41	0.127	3.530	-8.520	0.003	0.063	-0.081
XW 42	1.759	-0.643	16.418	0.073	-0.018	0.582
XY 43	0.062	-2.799	-11.645	0.002	-0.050	-0.110
BY 44	1.263	-2.477	-47.641	0.016	-0.021	-0.186
YZ 45	-0.673	-4.500	-59.287	-0.008	-0.038	-0.232
OX' 47	-1.747	-0.647	16.075	-0.022	-0.005	0.063
X'Y' 48	-0.059	-2.787	11.545	-0.002	-0.050	0.109
NY' 49	-1.256	-2.487	47.464	-0.016	-0.021	0.185
Y'Z'' 50	0.673	-4.500	59.008	0.008	-0.038	0.231

Table H5: Structural Analysis of Area D, Building 8, CCAD

Reaction and Stresses Due to Wind Loads

Member ID, #	Shear (kip)	Axial (kip)	Moment (kip-in)	Stress (ksi)		
				fv	fc,t	fb
BC 21	0.467	9.831	-20.167	0.025	0.349	-0.382
CD 11	-0.767	7.932	12.686	-0.032	0.219	0.290
DE 12	0.520	12.674	6.075	0.022	0.350	0.139
EF 13	-0.500	15.810	-4.810	-0.021	0.436	-0.110
FG 14	0.491	17.336	-5.070	0.020	0.478	-0.116
GH 15	-0.508	17.218	-5.587	-0.021	0.475	-0.128
HI 16	0.509	17.218	-5.544	0.021	0.475	-0.127
IJ 17	0.487	15.610	-4.413	0.020	0.431	-0.101
JK 18	-0.511	12.340	-5.147	-0.021	0.340	-0.118
KL 19	0.681	7.388	13.197	0.028	0.204	0.301
LM 20	0.592	0.606	7.252	0.024	0.017	0.166
MN 31	1.813	2.334	20.847	0.097	0.083	0.395
NX' 10	-1.534	-8.104	34.186	-0.063	-0.223	0.780
OP 9	0.545	-2.481	-5.772	0.023	-0.068	-0.132
PQ 8	0.521	-8.797	5.619	0.022	-0.243	0.128
QR 7	0.488	-13.664	-4.290	0.020	-0.377	-0.098
RS 6	0.520	-16.925	-5.781	0.022	-0.467	-0.132
ST 5	-0.505	-18.660	-6.199	-0.021	-0.515	-0.142
TU 4	-0.491	-17.134	-5.106	-0.020	-0.473	-0.117
UV 3	-0.515	-14.054	4.541	-0.021	-0.388	0.104
VW 2	-0.668	-9.350	9.755	-0.028	-0.258	0.223
XB 1	-0.729	0.415	8.940	-0.030	0.011	0.204
CW 32	-0.069	-11.742	-5.627	-0.002	-0.209	-0.053
DW 22	0.094	6.156	3.842	0.005	0.219	0.073
DV 33	0.094	-7.149	-6.747	0.003	-0.127	-0.064
VE 23	0.056	4.624	-4.038	0.003	0.164	-0.077
EU 34	0.000	-4.810	0.000	0.000	-0.133	0.000
UF 24	0.000	2.760	0.000	0.000	0.201	0.000
FT 35	0.000	-2.384	0.000	0.000	-0.087	0.000
TG 25	0.000	0.857	0.000	0.000	0.062	0.000
GS 36	0.000	0.185	0.000	0.000	0.013	0.000
SH 26	0.000	0.903	0.000	0.000	0.066	0.000
SI 37	0.000	-2.524	0.000	0.000	-0.184	0.000
IR 27	0.000	2.921	0.000	0.000	0.212	0.000
RJ 38	0.000	-5.095	0.000	0.000	-0.185	0.000
JQ 28	0.000	4.912	0.000	0.000	0.357	0.000
QK 39	0.000	-7.600	0.000	0.000	-0.210	0.000
KP 29	-0.087	6.567	6.243	-0.005	0.233	0.118
PL 40	0.017	-9.753	1.375	0.001	-0.347	0.026
LO 30	-0.551	8.553	25.602	-0.029	0.304	0.485
OM 41	-0.743	-2.887	41.524	-0.020	-0.051	0.394
XW 42	2.240	-1.791	-24.884	0.093	-0.049	-0.882
XY 43	-0.139	-2.981	-17.309	-0.004	-0.053	-0.164
BY 44	0.882	10.560	-48.448	0.011	0.088	-0.189
YZ 45	-1.324	8.551	132.914	-0.017	0.071	0.519
OX' 47	7.640	0.489	69.816	0.096	0.004	0.273
X'Y' 48	0.410	12.563	-60.109	0.011	0.223	-0.570
NY' 49	6.555	1.476	-231.130	0.082	0.012	-0.903
YZ'' 50	-5.758	10.649	330.047	-0.072	0.089	1.289

Table H6: Structural Analysis of Area D, Building 8, CCAD
Actual Total Stresses

Member ID, #	Load Comb.=D.L+L.L+Point L.				Load Comb.=D.L+W.L+Point L.			
	fv	ft	fc	fb	fv	ft	fc	fb
BC 21	-0.010		-0.405	0.157	0.019	0.114		-0.297
CD 11	0.052		-0.258	-0.331	-0.005	0.067		0.192
DE 12	0.037		-0.587	-0.322	0.039	0.003		-0.027
EF 13	0.032		-0.812	0.183	-0.006		-0.043	-0.011
FG 14	-0.031		-0.947	0.193	0.006		-0.081	-0.013
GH 15	0.033		-0.989	0.232	-0.006		-0.109	0.000
HI 16	-0.033		-0.989	0.234	0.006		-0.109	0.001
IJ 17	-0.030		-0.947	0.185	0.007		-0.128	-0.003
JK 18	0.032		-0.813	0.218	-0.007		-0.139	0.003
KL 19	-0.043		-0.584	-0.430	0.007		-0.141	0.072
LM 20	-0.050		-0.260	-0.498	-0.001		-0.136	-0.107
MN 31	0.009		-0.406	-0.148	0.102		-0.154	0.315
NX' 10	0.062	0.140		-0.674	-0.029		-0.141	0.389
OP 9	-0.043	0.208		-0.183	0.002	0.054		-0.173
PQ 8	-0.033	0.515		-0.144	0.006	0.061		0.076
QR 7	-0.031	0.739		0.187	0.006	0.059		0.003
RS 6	-0.033	0.873		0.255	0.006	0.049		0.009
ST 5	0.033	0.873		0.254	-0.006	0.001		-0.001
TU 4	0.030	0.738		0.190	-0.007		-0.037	-0.015
UV 3	0.035	0.517		-0.183	-0.005		-0.083	0.036
VW 2	0.034	0.203		0.202	-0.012		-0.138	0.336
XB 1	-0.062	0.141		-0.671	-0.064	0.095		-0.186
CW 32	-0.014	0.242		-0.320	-0.010		-0.065	-0.239
DW 22	-0.037		-0.516	0.589	-0.017		-0.079	0.420
DV 33	-0.001	0.311		0.038	0.002	0.057		-0.042
VE 23	-0.006		-0.389	0.165	-0.001		-0.058	0.020
EU 34	0.000	0.346		0.000	0.000	0.072		0.000
UF 24	0.000		-0.529	0.000	0.000		-0.097	0.000
FT 35	0.000	0.278		0.000	0.000	0.078		0.000
TG 25	0.000		-0.244	0.000	0.000		-0.067	0.000
GS 36	0.000	0.172		0.000	0.000	0.116		0.000
SH 26	0.000		-0.097	0.000	0.000	0.023		0.000
SI 37	0.000	0.173		0.000	0.000		-0.081	0.000
IR 27	0.000		-0.243	0.000	0.000	0.084		0.000
RJ 38	0.000	0.276		0.000	0.000		-0.022	0.000
JQ 28	0.000		-0.534	0.000	0.000	0.057		0.000
QK 39	0.000	0.350		0.000	0.000		-0.003	0.000
KP 29	0.009		-0.386	-0.232	0.001	0.013		-0.017
PL 40	0.002	0.606		0.039	0.002	0.011		0.048
LO 30	0.043		-0.510	-0.656	-0.004	0.010		0.099
OM 41	0.015	0.245		-0.338	-0.011	0.093		0.197
XW 42	0.275		-0.068	2.093	0.256		-0.090	0.380
XY 43	0.010		-0.198	-0.462	0.002		-0.169	-0.433
BY 44	0.062		-0.091	-0.732	0.047	0.036		-0.621
YZ 45	-0.033		-0.159	-0.923	-0.036		-0.021	-0.023
OX' 47	-0.077		-0.021	0.226	0.049		-0.008	0.409
X'Y' 48	-0.010		-0.197	0.458	0.006	0.107		-0.303
NY' 49	-0.061		-0.091	0.730	0.046		-0.040	-0.473
Y'Z'' 50	0.033		-0.159	0.918	-0.052		-0.003	1.829

Table H7: Allowable Stresses

Laboratory Test (ksi)		NDS (ksi), Unfactored	
Fb=	3.195	Fb=	2.100
Fc=	1.880	Fc=	1.750
Fv=	0.159	Fv=	0.090
Ft=	1.355	Ft=	1.100

Density=35 lb.ft³

Table H8: Structural Analysis of Area D, Building 8, CCAD

Adjustment Factors from NDS Specifications and Factored Allowables

Member ID, #	Load Comb.: D.L+L.L+P.L for Fb=1.7, Ft=.9, Fv=.1, Fc=1.7								Stress (ksi)			
	Cd	Cm	Ct	Cfu	Cv<1.0	Cf	Cp	Ch	F'b	F't	F'v	F'c
BC 21	1.25	1	1	1.000	1	1.100	0.981	1	2.888	1.513	0.113	2.361
CD 11	1.25	1	1	1.000	1	1.100	1.000	1	2.888	1.513	0.113	2.406
DE 12	1.25	1	1	1.000	1	1.100	1.000	1	2.888	1.513	0.113	2.406
EF 13	1.25	1	1	1.000	1	1.100	1.000	1	2.888	1.513	0.113	2.406
FG 14	1.25	1	1	1.000	1	1.100	1.000	1	2.888	1.513	0.113	2.406
GH 15	1.25	1	1	1.000	1	1.100	1.000	1	2.888	1.513	0.113	2.406
HI 16	1.25	1	1	1.000	1	1.100	1.000	1	2.888	1.513	0.113	2.406
IJ 17	1.25	1	1	1.000	1	1.100	1.000	1	2.888	1.513	0.113	2.406
JK 18	1.25	1	1	1.000	1	1.100	1.000	1	2.888	1.513	0.113	2.406
KL 19	1.25	1	1	1.000	1	1.100	1.000	1	2.888	1.513	0.113	2.406
LM 20	1.25	1	1	1.000	1	1.100	1.000	1	2.888	1.513	0.113	2.406
MN 31	1.25	1	1	1.000	1	1.100	0.981	1	2.888	1.513	0.113	2.361
NX' 10	1.25	1	1	1.000	1	1.100	1.000	1	2.888	1.513	0.113	2.406
OP 9	1.25	1	1	1.000	1	1.100	1.000	1	2.888	1.513	0.113	2.406
PQ 8	1.25	1	1	1.000	1	1.100	1.000	1	2.888	1.513	0.113	2.406
QR 7	1.25	1	1	1.000	1	1.100	1.000	1	2.888	1.513	0.113	2.406
RS 6	1.25	1	1	1.000	1	1.100	1.000	1	2.888	1.513	0.113	2.406
ST 5	1.25	1	1	1.000	1	1.100	1.000	1	2.888	1.513	0.113	2.406
TU 4	1.25	1	1	1.000	1	1.100	1.000	1	2.888	1.513	0.113	2.406
UV 3	1.25	1	1	1.000	1	1.100	1.000	1	2.888	1.513	0.113	2.406
VW 2	1.25	1	1	1.000	1	1.100	1.000	1	2.888	1.513	0.113	2.406
XB 1	1.25	1	1	1.000	1	1.100	1.000	1	2.888	1.513	0.113	2.406
CW 32	1.25	1	1	1.000	1	1.100	1.000	1	2.888	1.513	0.113	2.406
DW 22	1.25	1	1	1.000	1	1.100	0.981	1	2.888	1.513	0.113	2.361
DV 33	1.25	1	1	1.000	1	1.100	1.000	1	2.888	1.513	0.113	2.406
VE 23	1.25	1	1	1.000	1	1.100	0.981	1	2.888	1.513	0.113	2.361
EU 34	1.25	1	1	1.000	1	1.100	1.000	1	2.888	1.513	0.113	2.406
UF 24	1.25	1	1	1.000	1	1.100	0.981	1	2.888	1.513	0.113	2.361
FT 35	1.25	1	1	1.000	1	1.100	1.000	1	2.888	1.513	0.113	2.406
TG 25	1.25	1	1	1.000	1	1.100	0.981	1	2.888	1.513	0.113	2.361
GS 36	1.25	1	1	1.000	1	1.100	1.000	1	2.888	1.513	0.113	2.406
SH 26	1.25	1	1	1.000	1	1.100	0.981	1	2.888	1.513	0.113	2.361
SI 37	1.25	1	1	1.000	1	1.100	1.000	1	2.888	1.513	0.113	2.406
IR 27	1.25	1	1	1.000	1	1.100	0.981	1	2.888	1.513	0.113	2.361
RJ 38	1.25	1	1	1.000	1	1.100	1.000	1	2.888	1.513	0.113	2.406
JQ 28	1.25	1	1	1.000	1	1.100	0.981	1	2.888	1.513	0.113	2.361
QK 39	1.25	1	1	1.000	1	1.100	1.000	1	2.888	1.513	0.113	2.406
KP 29	1.25	1	1	1.000	1	1.100	0.981	1	2.888	1.513	0.113	2.361
PL 40	1.25	1	1	1.000	1	1.100	1.000	1	2.888	1.513	0.113	2.406
LO 30	1.25	1	1	1.000	1	1.100	0.981	1	2.888	1.513	0.113	2.361
OM 41	1.25	1	1	1.000	1	1.100	1.000	1	2.888	1.513	0.113	2.406
XW 42	1.25	1	1	1.000	1	1.100	1.000	1	2.888	1.513	0.113	2.406
XY 43	1.25	1	1	1.000	1	1.100	1.000	1	2.888	1.513	0.113	2.406
BY 44	1.25	1	1	1.000	1	1.100	0.974	1	2.888	1.513	0.113	2.344
YZ 45	1.25	1	1	1.000	1	1.100	0.891	1	2.888	1.513	0.113	2.144
OX' 47	1.25	1	1	1.000	1	1.100	1.000	1	2.888	1.513	0.113	2.406
X'Y' 48	1.25	1	1	1.000	1	1.100	1.000	1	2.888	1.513	0.113	2.406
NY' 49	1.25	1	1	1.000	1	1.100	0.974	1	2.888	1.513	0.113	2.344
Y'Z'' 50	1.25	1	1	1.000	1	1.100	0.891	1	2.888	1.513	0.113	2.144

Cd=1.0 due to occupancy Live Load

When Cv is determined, some vales are used conventionally.

Ch=1.0 for assuming splits at all members.

Table H9: Structural Analysis of Area D, Building 8, CCAD

Adjustment Factors from NDS Specifications and Factored Allowables

Member ID, #	Load Comb.: D.L+W.L+P.L for Fb=1.7, Ft=.9, Fv=1, Fc=1.7									(ksi)			
	Cd	Cm	Ct	Cfu	Cv<1.0	Cf	Cp	Ch	F'b	F't	F'v	F'c	
BC 21	1.60	1	1	1	1	1.1	0.981	1	3.696	1.760	0.144	3.021	
CD 11	1.60	1	1	1	1	1.1	1.000	1	3.866	1.841	0.144	3.080	
DE 12	1.60	1	1	1	1	1.1	1.000	1	3.866	1.841	0.144	3.080	
EF 13	1.60	1	1	1	1	1.1	1.000	1	3.866	1.841	0.144	3.080	
FG 14	1.60	1	1	1	1	1.1	1.000	1	3.866	1.841	0.144	3.080	
GH 15	1.60	1	1	1	1	1.1	1.000	1	3.866	1.841	0.144	3.080	
HI 16	1.60	1	1	1	1	1.1	1.000	1	3.866	1.841	0.144	3.080	
IJ 17	1.60	1	1	1	1	1.1	1.000	1	3.866	1.841	0.144	3.080	
JK 18	1.60	1	1	1	1	1.1	1.000	1	3.866	1.841	0.144	3.080	
KL 19	1.60	1	1	1	1	1.1	1.000	1	3.866	1.841	0.144	3.080	
LM 20	1.60	1	1	1	1	1.1	1.000	1	3.866	1.841	0.144	3.080	
MN 31	1.60	1	1	1	1	1.1	0.981	1	3.696	1.760	0.144	3.021	
NX' 10	1.60	1	1	1	1	1.1	1.000	1	3.866	1.841	0.144	3.080	
OP 9	1.60	1	1	1	1	1.1	1.000	1	3.866	1.841	0.144	3.080	
PQ 8	1.60	1	1	1	1	1.1	1.000	1	3.866	1.841	0.144	3.080	
QR 7	1.60	1	1	1	1	1.1	1.000	1	3.866	1.841	0.144	3.080	
RS 6	1.60	1	1	1	1	1.1	1.000	1	3.866	1.841	0.144	3.080	
ST 5	1.60	1	1	1	1	1.1	1.000	1	3.866	1.841	0.144	3.080	
TU 4	1.60	1	1	1	1	1.1	1.000	1	3.866	1.841	0.144	3.080	
UV 3	1.60	1	1	1	1	1.1	1.000	1	3.866	1.841	0.144	3.080	
VW 2	1.60	1	1	1	1	1.1	1.000	1	3.866	1.841	0.144	3.080	
XB 1	1.60	1	1	1	1	1.1	1.000	1	3.866	1.841	0.144	3.080	
CW 32	1.60	1	1	1	1	1.1	1.000	1	3.696	1.760	0.144	3.080	
DW 22	1.60	1	1	1	1	1.1	0.981	1	3.696	1.760	0.144	3.021	
DV 33	1.60	1	1	1	1	1.1	1.000	1	3.696	1.760	0.144	3.080	
VE 23	1.60	1	1	1	1	1.1	0.981	1	3.696	1.760	0.144	3.021	
EU 34	1.60	1	1	1	1	1.1	1.000	1	3.866	1.841	0.144	3.080	
UF 24	1.60	1	1	1	1	1.1	0.981	1	3.992	1.901	0.144	3.021	
FT 35	1.60	1	1	1	1	1.1	1.000	1	3.992	1.901	0.144	3.080	
TG 25	1.60	1	1	1	1	1.1	0.981	1	3.992	1.901	0.144	3.021	
GS 36	1.60	1	1	1	1	1.1	1.000	1	3.992	1.901	0.144	3.080	
SH 26	1.60	1	1	1	1	1.1	0.981	1	3.992	1.901	0.144	3.021	
SI 37	1.60	1	1	1	1	1.1	1.000	1	3.992	1.901	0.144	3.080	
IR 27	1.60	1	1	1	1	1.1	0.981	1	3.992	1.901	0.144	3.021	
RJ 38	1.60	1	1	1	1	1.1	1.000	1	3.992	1.901	0.144	3.080	
JQ 28	1.60	1	1	1	1	1.1	0.981	1	3.992	1.901	0.144	3.021	
QK 39	1.60	1	1	1	1	1.1	1.000	1	3.866	1.841	0.144	3.080	
KP 29	1.60	1	1	1	1	1.1	0.981	1	3.696	1.760	0.144	3.021	
PL 40	1.60	1	1	1	1	1.1	1.000	1	3.696	1.760	0.144	3.080	
LO 30	1.60	1	1	1	1	1.1	0.981	1	3.696	1.760	0.144	3.021	
OM 41	1.60	1	1	1	1	1.1	1.000	1	3.696	1.760	0.144	3.080	
XW 42	1.60	1	1	1	1	1.1	1.000	1	3.866	1.841	0.144	3.080	
XY 43	1.60	1	1	1	1	1.1	1.000	1	3.696	1.760	0.144	3.080	
BY 44	1.60	1	1	1	1	1.1	0.974	1	3.696	1.760	0.144	3.000	
YZ 45	1.60	1	1	1	1	1.1	0.891	1	3.696	1.760	0.144	2.744	
OX' 47	1.60	1	1	1	1	1.1	1.000	1	3.866	1.841	0.144	3.080	
X'Y' 48	1.60	1	1	1	1	1.1	1.000	1	3.696	1.760	0.144	3.080	
NY' 49	1.60	1	1	1	1	1.1	0.974	1	3.696	1.760	0.144	3.000	
YZ'' 50	1.60	1	1	1	1	1.1	0.891	1	3.696	1.760	0.144	2.744	

Cd=1.6 due to Wind Load

When Cv is determined, some vales are used conventionally.

Ch=1.0 for assuming splits at all members.

Table H10: Structural Analysis of Area D, Building 8, CCAD
Stress Interaction Per NDS Allowables

Member ID,	#	Load Comb.:D.L+L.L+Point L.			Load Comb.:D.L+W.L+Point L.		
		I (b,t)*	I (b,t) **	I (b,c) ***	I (b,t)*	I (b,t) **	I (b,c) ***
BC	21			0.095	0.145	0.050	
CD	11			0.140	0.086	0.032	
DE	12			0.207	0.009	0.006	
EF	13			0.210			0.003
FG	14			0.265			0.004
GH	15			0.305			0.001
HI	16			0.306			0.002
IJ	17			0.260			0.002
JK	18			0.228			0.003
KL	19			0.255			0.022
LM	20			0.205			0.031
MN	31			0.092			0.092
NX'	10	0.326	0.185				0.108
OP	9	0.201	0.009		0.074	0.031	
PQ	8	0.390	0.128		0.053	0.004	
QR	7	0.553	0.191		0.033	0.015	
RS	6	0.666	0.214		0.029	0.010	
ST	5	0.665	0.214		0.001	0.000	
TU	4	0.554	0.190				0.004
UV	3	0.405	0.116				0.010
VW	2	0.204	0.000				0.093
XB	1	0.326	0.184		0.099	0.024	
CW	32	0.271	0.027				0.067
DW	22			0.309			0.117
DV	33	0.219	0.095		0.044	0.004	
VE	23			0.096			0.006
EU	34	0.229	0.120		0.039	0.018	
UF	24			0.050			0.001
FT	35	0.184	0.096		0.041	0.019	
TG	25			0.011			0.000
GS	36	0.114	0.060		0.061	0.029	
SH	26			0.002	0.012	0.006	
SI	37	0.114	0.060				0.001
IR	27			0.011	0.044	0.021	
RJ	38	0.183	0.096				0.000
JQ	28			0.051	0.030	0.014	
QK	39	0.231	0.121				0.000
KP	29			0.123	0.012	0.001	
PL	40	0.414	0.196		0.019	0.010	
LO	30			0.337	0.032	0.024	
OM	41	0.279	0.032		0.106	0.028	
XW	42			0.747			0.102
XY	43			0.181			0.127
BY	44			0.265	0.188	0.158	
YZ	45			0.351			0.006
OX'	47			0.079			0.106
X'Y'	48			0.180	0.143	0.053	
NY'	49			0.264			0.130
YZ''	50			0.349			0.496

*: $f_t/F_t + f_b/F_b < 1.0$

** : $(f_b - f_t)/F_b < 1.0$

***: $(f_c/F_c)^2 + f_b/(F_b * (1 - (f_c/F_c))) < 1.0$

Table H11: Structural Analysis of Area D, Building 8, CCAD

Stress Interaction Based on Lab. Test Allowables

Member ID, #		Load Comb.:D.L+L.L+Point L.			Load Comb.:D.L+W.L+Point L.		
		I (b,t)*	I (b,t) **	I (b,c) ***	I (b,t)*	I (b,t) **	I (b,c) ***
BC	21			0.109	0.177	0.057	
CD	11			0.139	0.109	0.039	
DE	12			0.244	0.011	0.007	
EF	13			0.287			0.004
FG	14			0.375			0.006
GH	15			0.430			0.003
HI	16			0.431			0.004
IJ	17			0.370			0.006
JK	18			0.307			0.007
KL	19			0.292			0.030
LM	20			0.200			0.041
MN	31			0.106			0.114
NX'	10	0.315	0.167				0.137
OP	9	0.211	0.008		0.094	0.037	
PQ	8	0.425	0.116		0.069	0.005	
QR	7	0.604	0.173		0.045	0.018	
RS	6	0.724	0.193		0.039	0.012	
ST	5	0.724	0.194		0.001	0.000	
TU	4	0.604	0.172				0.005
UV	3	0.439	0.105				0.014
VW	2	0.213	0.000			0.105	
XB	1	0.314	0.166		0.128	0.028	
CW	32	0.279	0.024				0.079
DW	22			0.330			0.139
DV	33	0.242	0.086		0.055	0.005	
VE	23			0.108			0.008
EU	34	0.255	0.108		0.053	0.022	
UF	24			0.079			0.003
FT	35	0.205	0.087		0.057	0.024	
TG	25			0.017			0.001
GS	36	0.127	0.054		0.085	0.036	
SH	26			0.003	0.017	0.007	
SI	37	0.127	0.054				0.002
IR	27			0.017	0.062	0.026	
RJ	38	0.204	0.087				0.000
JQ	28			0.081	0.042	0.018	
QK	39	0.258	0.110				0.000
KP	29			0.133	0.015	0.002	
PL	40	0.459	0.177		0.023	0.012	
LO	30			0.356	0.038	0.028	
OM	41	0.286	0.029		0.131	0.033	
XW	42			0.681			0.127
XY	43			0.173			0.157
BY	44			0.243	0.221	0.183	
YZ	45			0.323			0.008
OX'	47			0.072			0.129
X'Y'	48			0.171	0.174	0.061	
NY'	49			0.242			0.152
YZ'	50			0.321			0.574

*: $f_t/F_t + f_b/F_b < 1.0$ **: $(f_b - f_t)/F_b < 1.0$ ***: $(f_c/F_c)^2 + f_b/(F_b * (1 - (f_c/F_c))) < 1.0$

Table H12: Connection Evaluation in Area D

Joint Type	I.D.	Position	Angle (Deg.)	Angle (Rad.)	# of Bolts	P	Q	CD	Cm	Ct	Cg	Cdelta	Cd	Cst	P'	Q'	Sina	Cosa	n	N(n**#)	Axial Load	Result Load	Half of Result	Interaction
Load Combination=D.L+L.L+PL																								
J1	BW	out	90	1.57	2	6.14	4.27	1.25	1	1	0.502	1	1	1.18	4.55	2.68	1.000	0.000	2.68	5.36	5.12	12.47	6.235	1.163
	BC	in	0	0.00	2	6.14	4.27	1.25	1	1	0.502	1	1	1.18	4.55	2.68	0.000	1.000	4.55	9.09	-11.38			0.686
J2	CB	in	0	0.00	2	6.14	4.27	1.25	1	1	0.502	1	1	1.18	4.55	2.68	0.000	1.000	4.55	9.09	-11.38			0.077
	CW	in	43	0.75	2	6.14	4.27	1.25	1	1	0.502	1	1	1.18	4.55	2.68	0.682	0.731	3.43	6.87	13.60			0.102
	CW	out	0	0.00	2	6.14	4.27	1.25	1	1	0.502	1	1	1.18	4.55	2.68	0.000	1.000	4.55	9.09	13.60			0.077
	CD	out	47	0.82	2	6.14	4.27	1.25	1	1	0.502	1	1	1.18	4.55	2.68	0.731	0.682	3.31	6.62	-9.34	1.4	0.7	0.106
J3	FU	in	0	0.00	1	6.14	4.27	1.25	1	1	0.502	1	1	1.18	4.55	2.68	0.000	1.000	4.55	4.55	-7.28			0.190
	FT	out	43	0.75	1	6.14	4.27	1.25	1	1	0.502	1	1	1.18	4.55	2.68	0.682	0.731	3.43	3.43	7.64			0.252
	FT	in	0	0.00	1	6.14	4.27	1.25	1	1	0.502	1	1	1.18	4.55	2.68	0.000	1.000	4.55	4.55	7.64			0.190
	FG	out	47	0.82	1	6.14	4.27	1.25	1	1	0.502	1	1	1.18	4.55	2.68	0.731	0.682	3.31	3.31	-34.33	1.73	0.865	0.261
J4	HS	in	0	0.00	1	6.14	4.27	1.25	1	1	0.502	1	1	1.18	4.55	2.68	0.000	1.000	4.55	4.55	-1.33			0.935
	HI	out	90	1.57	1	6.14	4.27	1.25	1	1	0.502	1	1	1.18	4.55	2.68	1.000	0.000	2.68	2.68	-26.70	8.5	4.25	1.586
J5	HS	in	0	0.00	1	6.14	4.27	1.25	1	1	0.502	1	1	1.18	4.55	2.68	0.000	1.000	4.55	4.55	-1.33			0.177
	GS	out	43	0.75	1	6.14	4.27	1.25	1	1	0.502	1	1	1.18	4.55	2.68	0.682	0.731	3.43	3.43	2.37			0.234
	GS	in	0	0.00	1	6.14	4.27	1.25	1	1	0.502	1	1	1.18	4.55	2.68	0.000	1.000	4.55	4.55	2.37			0.177
	TS	out	47	0.82	1	6.14	4.27	1.25	1	1	0.502	1	1	1.18	4.55	2.68	0.731	0.682	3.31	3.31	-3.18	1.61	0.805	0.243

Load Combination=D.L+WL+PL

Joint Type	I.D.	Position	Angle (Deg.)	Angle (Rad.)	# of Bolts	P	Q	CD	Cm	Ct	Cg	Cdelta	Cd	Cst	P'	Q'	Sina	Cosa	n	N(n**#)	Axial Load	Result Load	Half of Result	Interaction
Load Combination=D.L+WL+PL																								
J1	BW	out	90	1.57	2	6.14	4.27	1.6	1	1	0.502	1	1	1.18	5.82	3.43	1.000	0.000	3.43	6.86	3.42			0.340
	BC	in	0	0.00	2	6.14	4.27	1.6	1	1	0.502	1	1	1.18	5.82	3.43	0.000	1.000	5.82	11.64	3.18	4.67	2.335	0.201
J2	CB	in	0	0.00	2	6.14	4.27	1.6	1	1	0.502	1	1	1.18	5.82	3.43	0.000	1.000	5.82	11.64	3.18			0.021
	CW	in	43	0.75	2	6.14	4.27	1.6	1	1	0.502	1	1	1.18	5.82	3.43	0.682	0.731	4.40	8.79	-3.68			0.028
	CW	out	0	0.00	2	6.14	4.27	1.6	1	1	0.502	1	1	1.18	5.82	3.43	0.000	1.000	5.82	11.64	-3.68			0.021
	CD	out	47	0.82	2	6.14	4.27	1.6	1	1	0.502	1	1	1.18	5.82	3.43	0.731	0.682	4.24	8.48	2.43	0.489	0.245	0.029
J3	FU	in	0	0.00	1	6.14	4.27	1.6	1	1	0.502	1	1	1.18	5.82	3.43	0.000	1.000	5.82	5.82	-4.52			0.283
	FT	out	43	0.75	1	6.14	4.27	1.6	1	1	0.502	1	1	1.18	5.82	3.43	0.682	0.731	4.40	4.40	2.13			0.374
	FT	in	0	0.00	1	6.14	4.27	1.6	1	1	0.502	1	1	1.18	5.82	3.43	0.000	1.000	5.82	5.82	2.13			0.283
	FG	out	47	0.82	1	6.14	4.27	1.6	1	1	0.502	1	1	1.18	5.82	3.43	0.731	0.682	4.24	4.24	-2.90	3.29	1.645	0.388
J4	HS	in	0	0.00	1	6.14	4.27	1.6	1	1	0.502	1	1	1.18	5.82	3.43	0.000	1.000	5.82	5.82	-0.43			0.339
	HI	out	90	1.57	1	6.14	4.27	1.6	1	1	0.502	1	1	1.18	5.82	3.43	1.000	0.000	3.43	3.43	-3.92	3.94	1.97	0.574
J5	HS	in	0	0.00	1	6.14	4.27	1.6	1	1	0.502	1	1	1.18	5.82	3.43	0.000	1.000	5.82	5.82	-0.43			0.121
	GS	out	43	0.75	1	6.14	4.27	1.6	1	1	0.502	1	1	1.18	5.82	3.43	0.682	0.731	4.40	4.40	1.60			0.160
	GS	in	0	0.00	1	6.14	4.27	1.6	1	1	0.502	1	1	1.18	5.82	3.43	0.000	1.000	5.82	5.82	1.60			0.121
	TS	out	47	0.82	1	6.14	4.27	1.6	1	1	0.502	1	1	1.18	5.82	3.43	0.731	0.682	4.24	4.24	0.08	1.41	0.705	0.166

Appendix I: Diagrams of Proposed Repairs

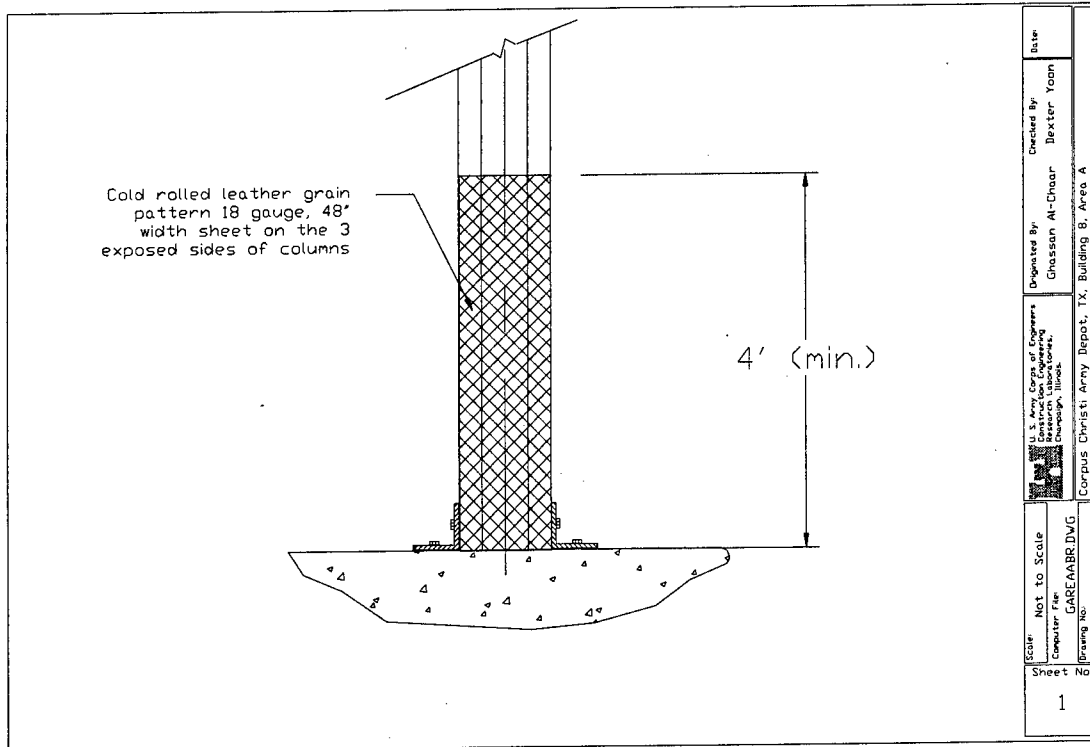

Figure I1. Proposed Protection for the bottom of columns along the M column line in Area A.

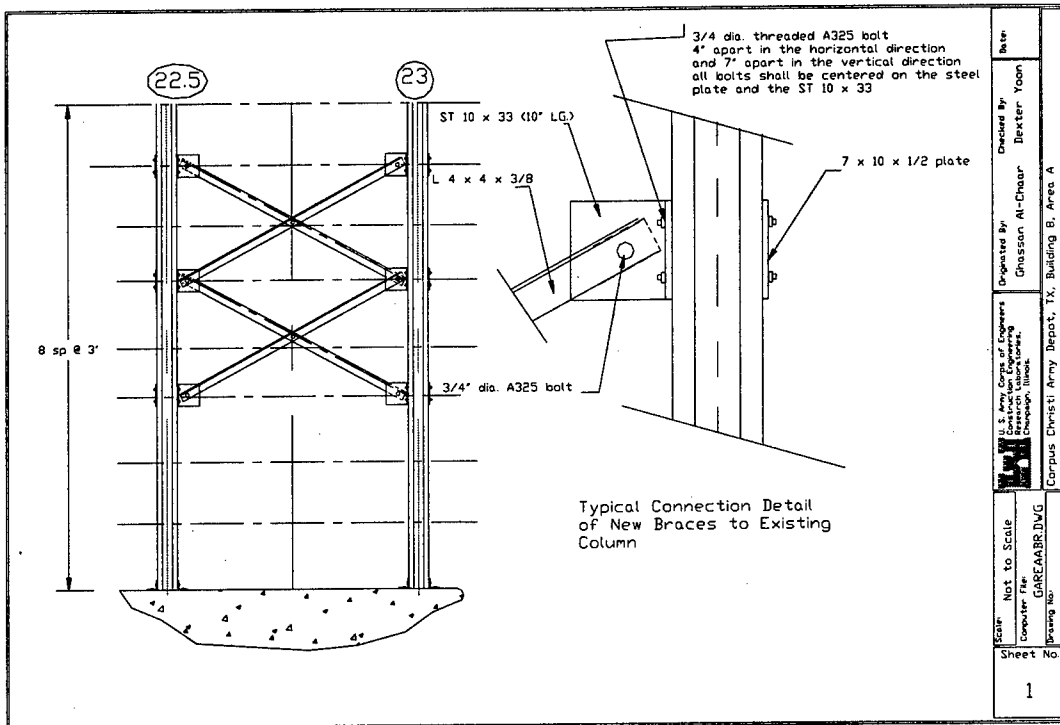

Figure I2-1. Proposed braces for bay 22.5 – 23 along column line M.

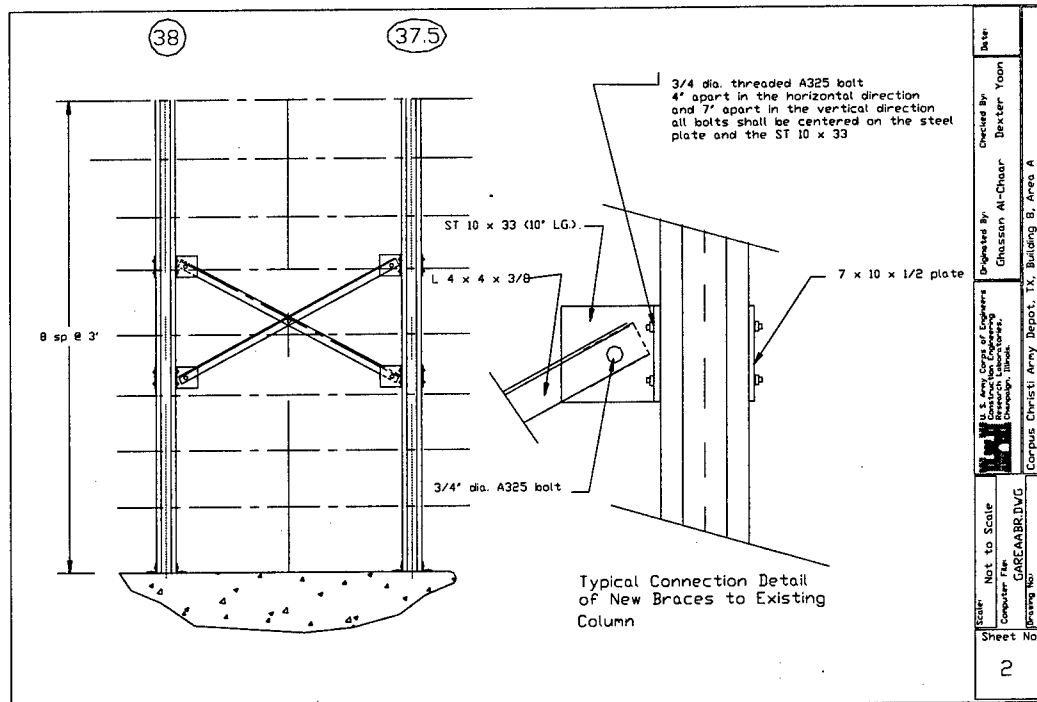

Figure I2-2. Proposed braces for bay 37.5 – 38 along column line M.

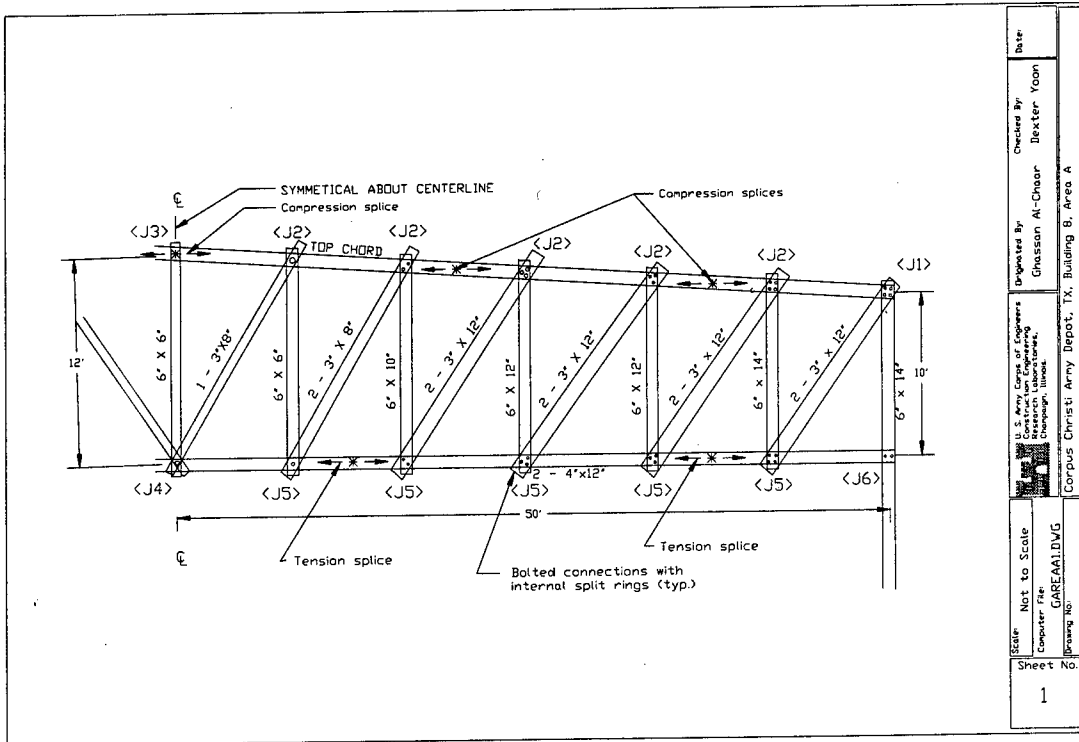

Figure 13. Joint types and splice locations on a typical truss in Area A.

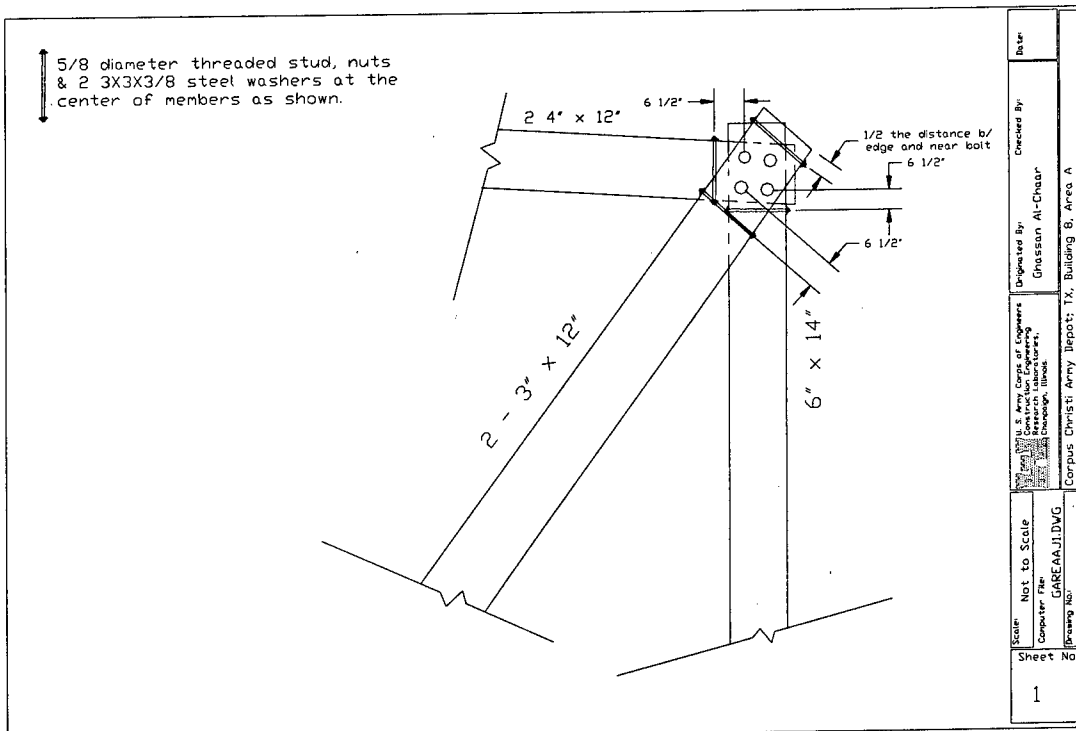

Figure 14. Proposed repair for end splits of joint type <J1>.

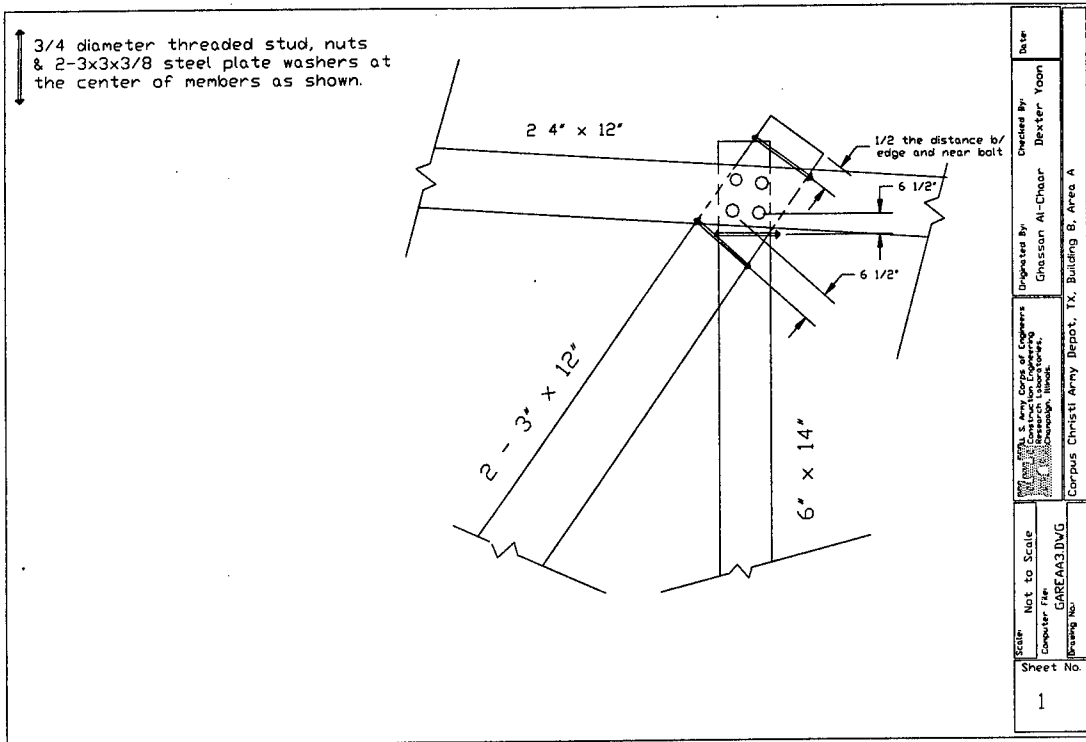

Figure 15. Proposed repair for end splits joint type <J2>.

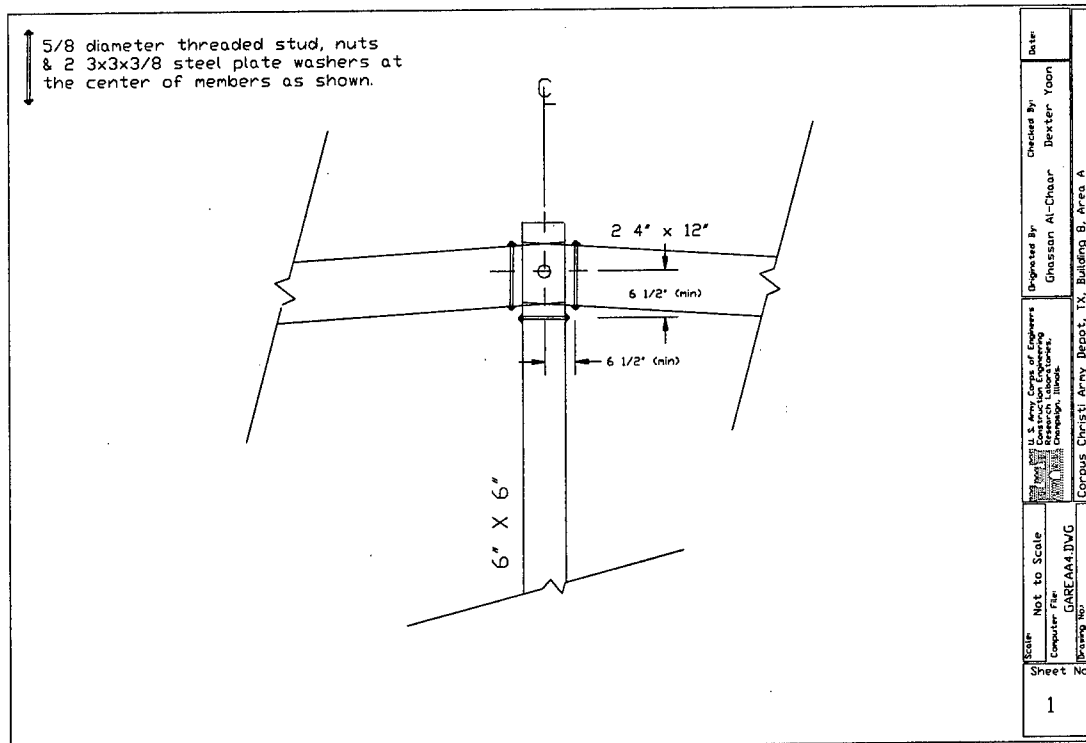

Figure 16. Proposed repair for end splits joint type <J3>.

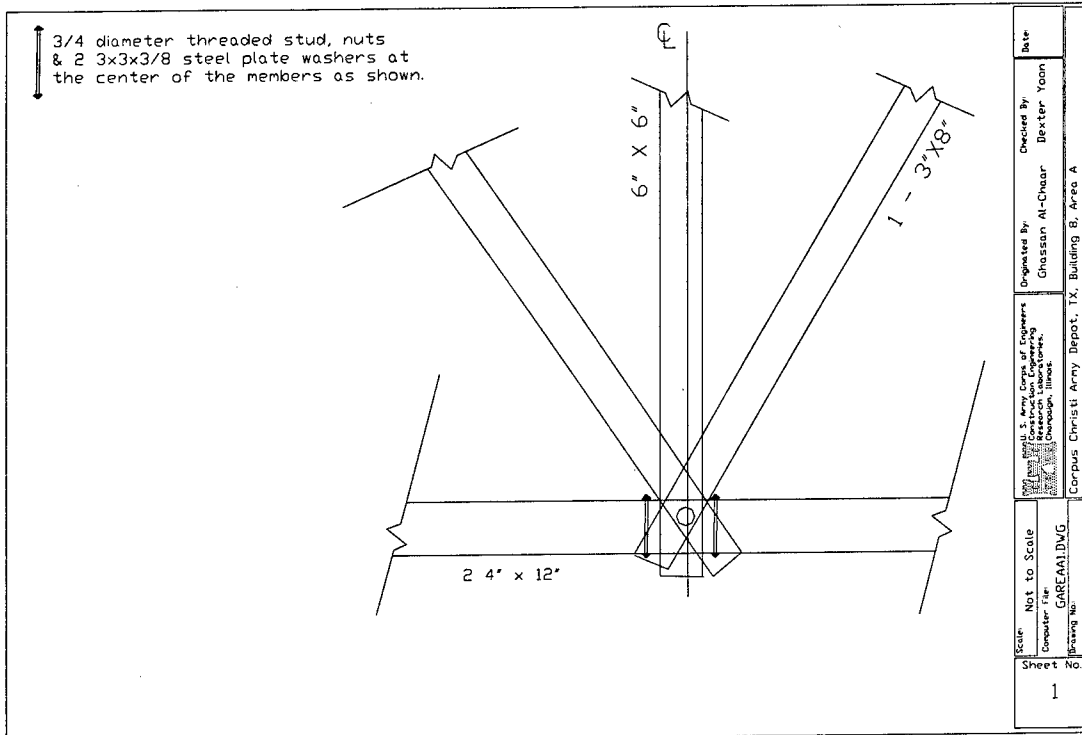

Figure 17. Proposed repair for end splits joint type <J4>.

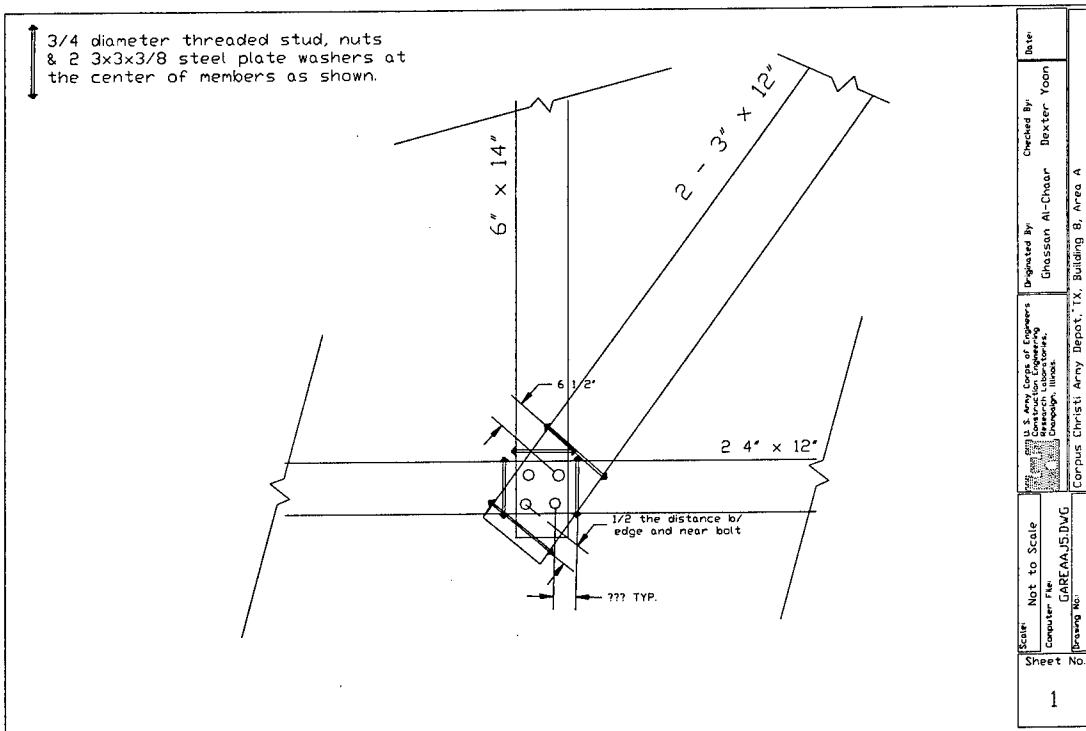

Figure 18. Proposed repair for end splits in joints type <J5>.

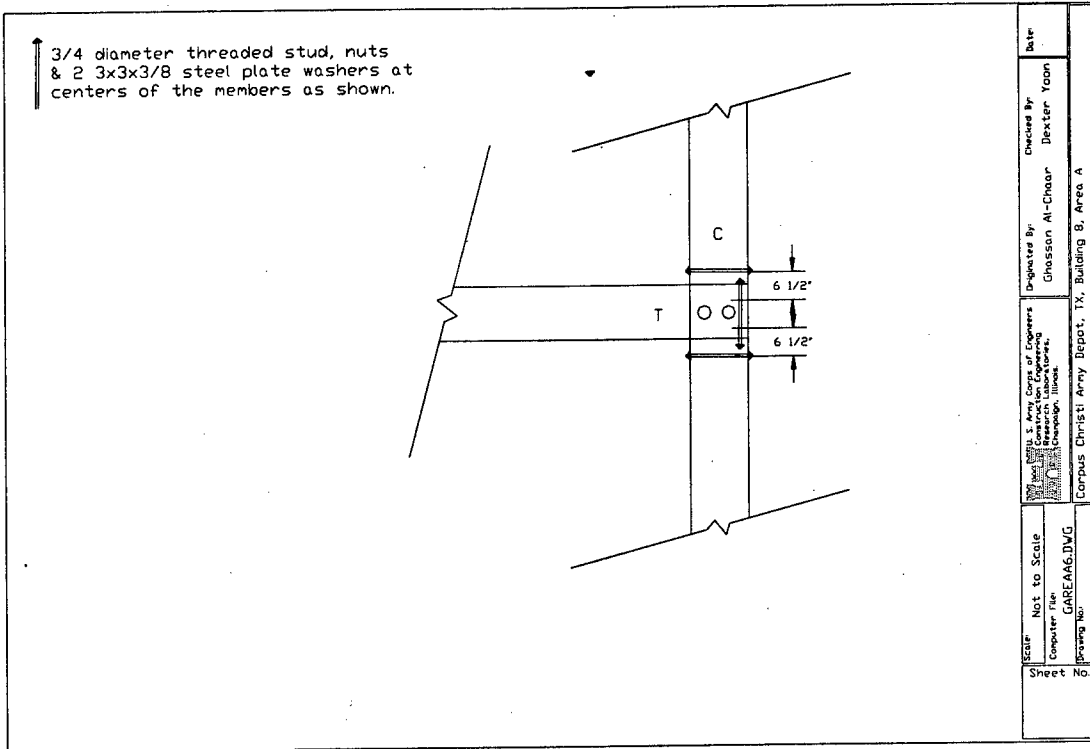

Figure I9. Proposed repair for end splits joint type <J6>.

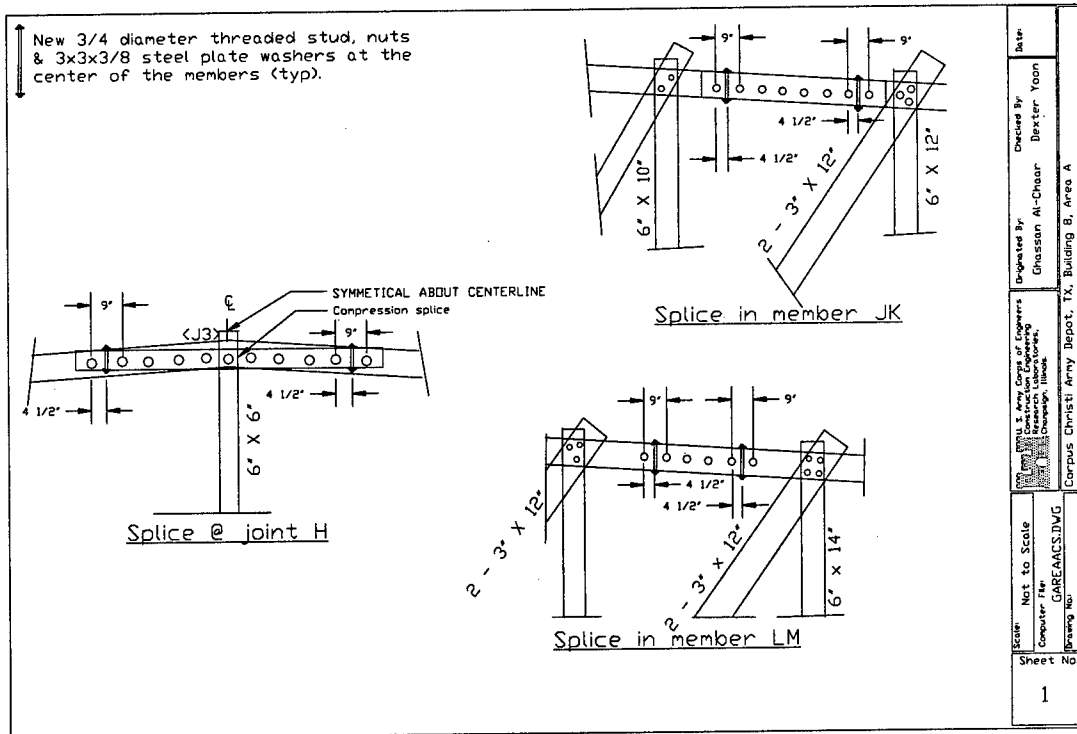

Figure I10. Proposed repair for end split in compression splices.

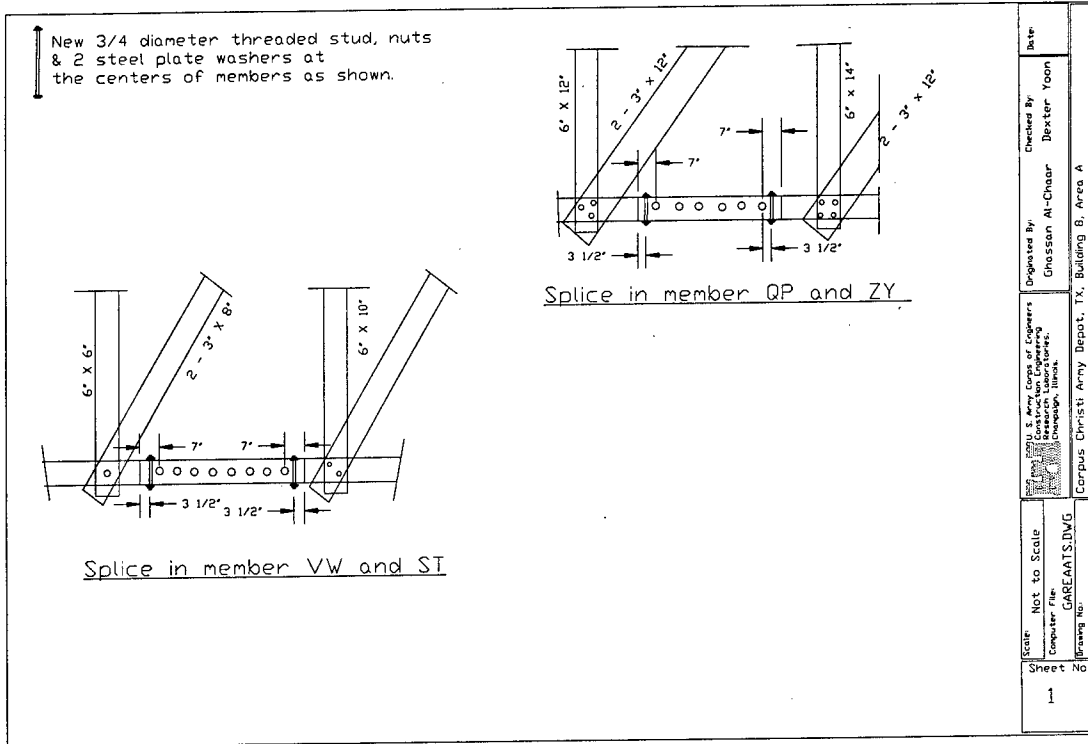

Figure I11. Proposed repair for end split in tension splices.

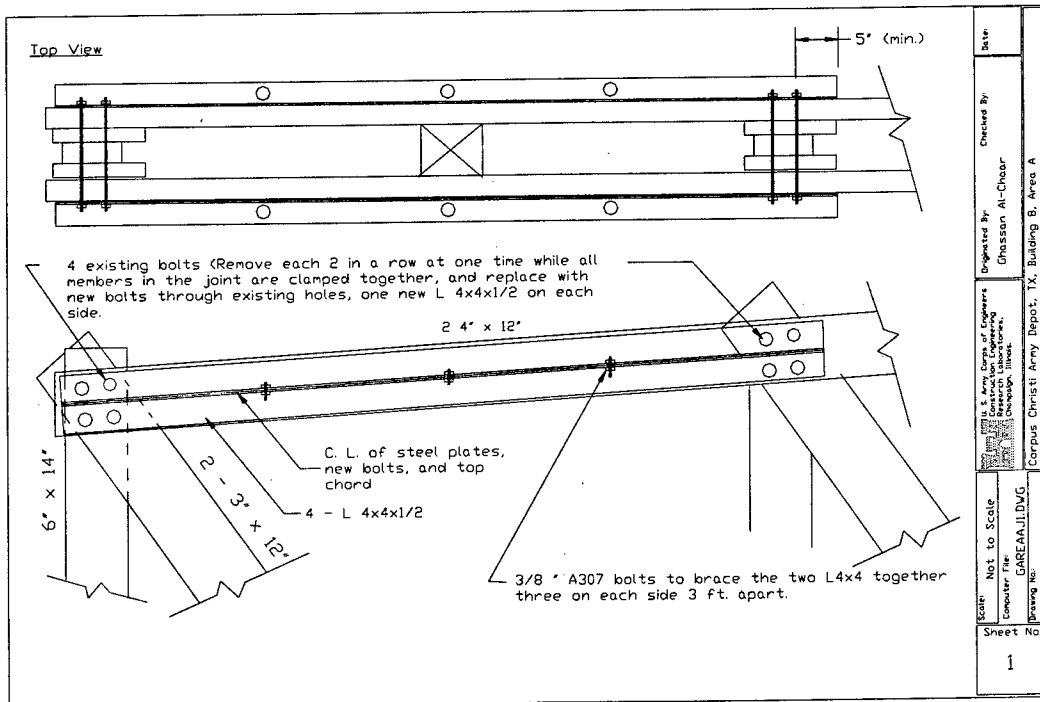

Figure I12. Proposed repair for decayed Joint B of Truss 24.5.

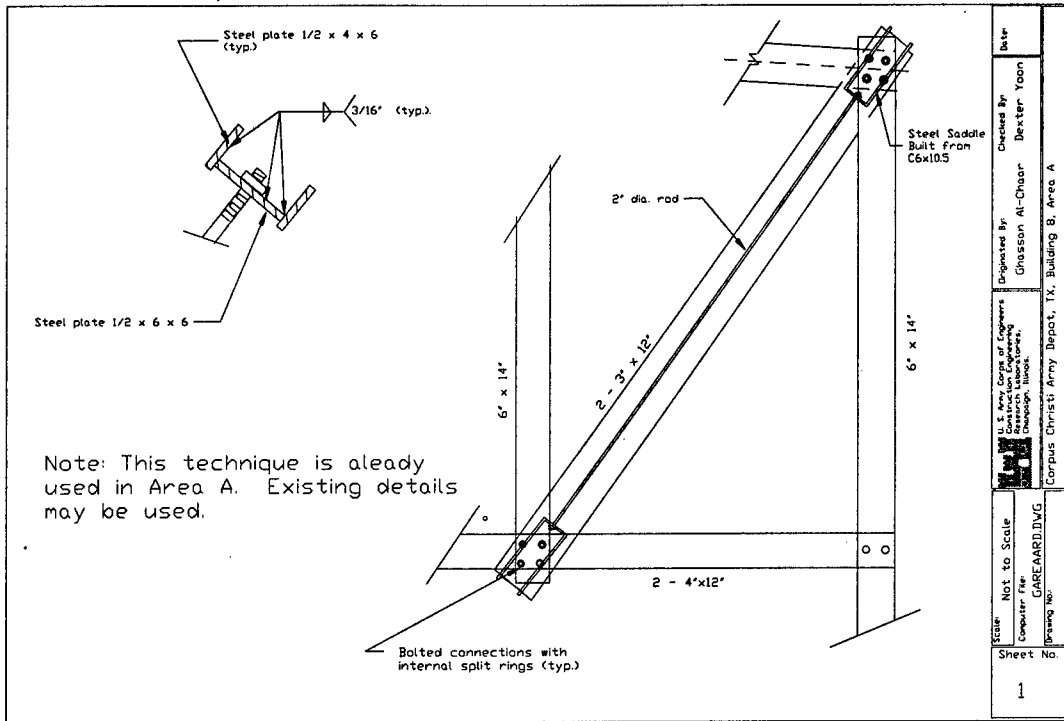

Figure I13. Repair of diagonal members by tension rods.

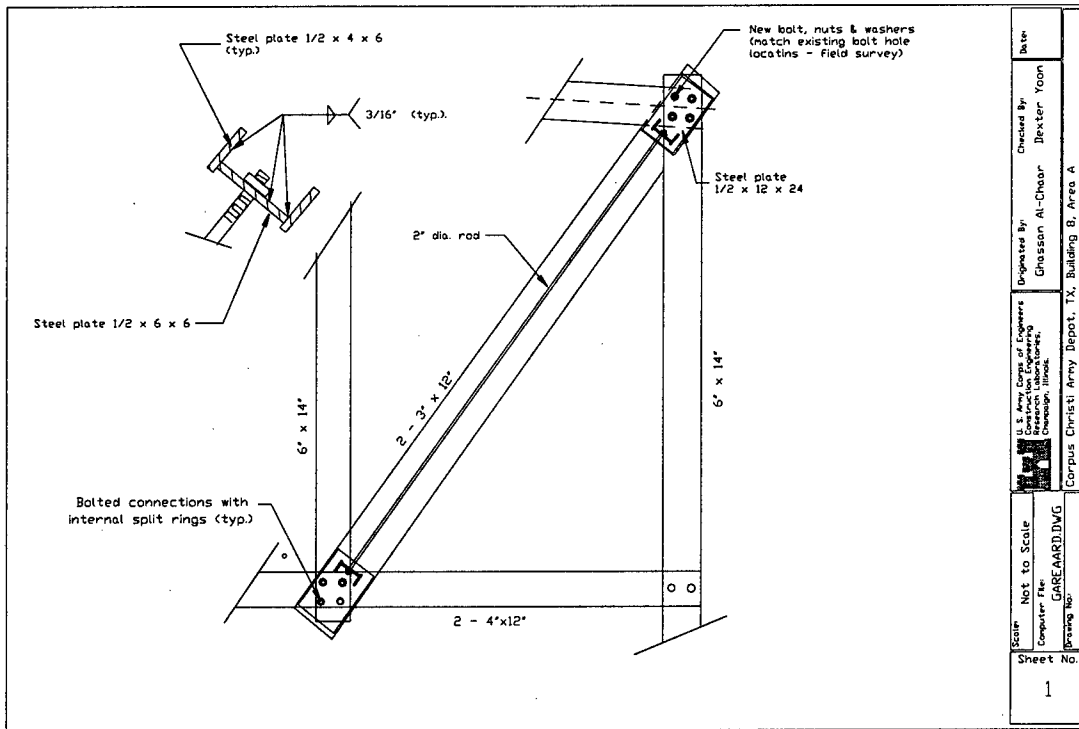

Figure I14. Proposed repair of diagonal chords by tension rods.

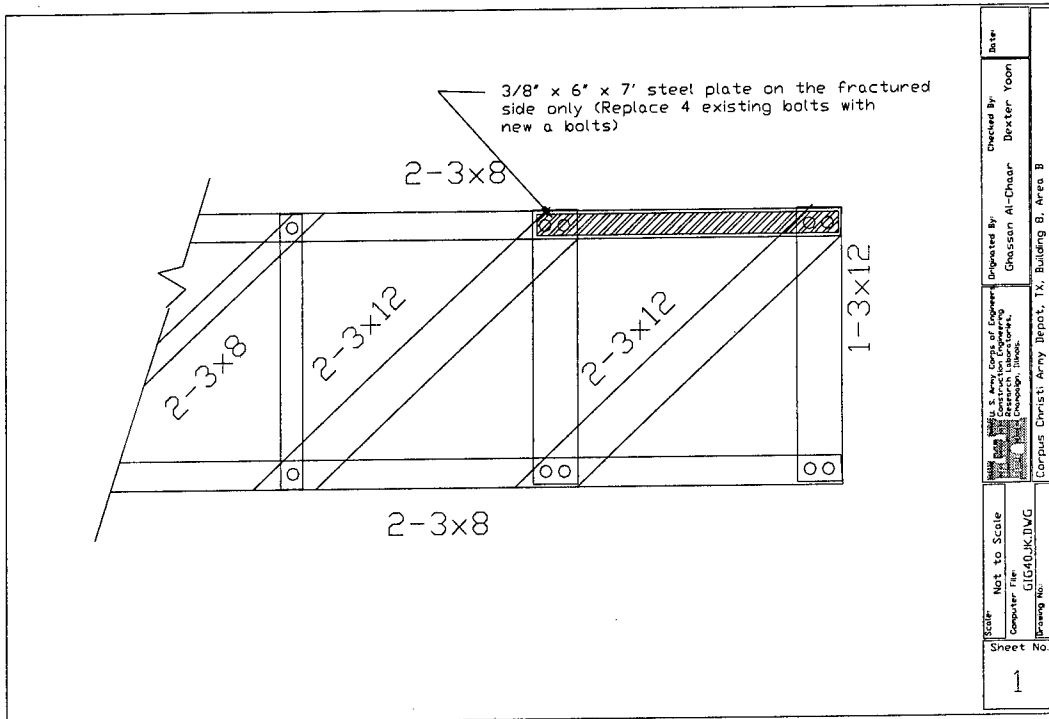

Figure I15. Proposed repair for member JK Truss Column Line 40, Section IG, Area B.

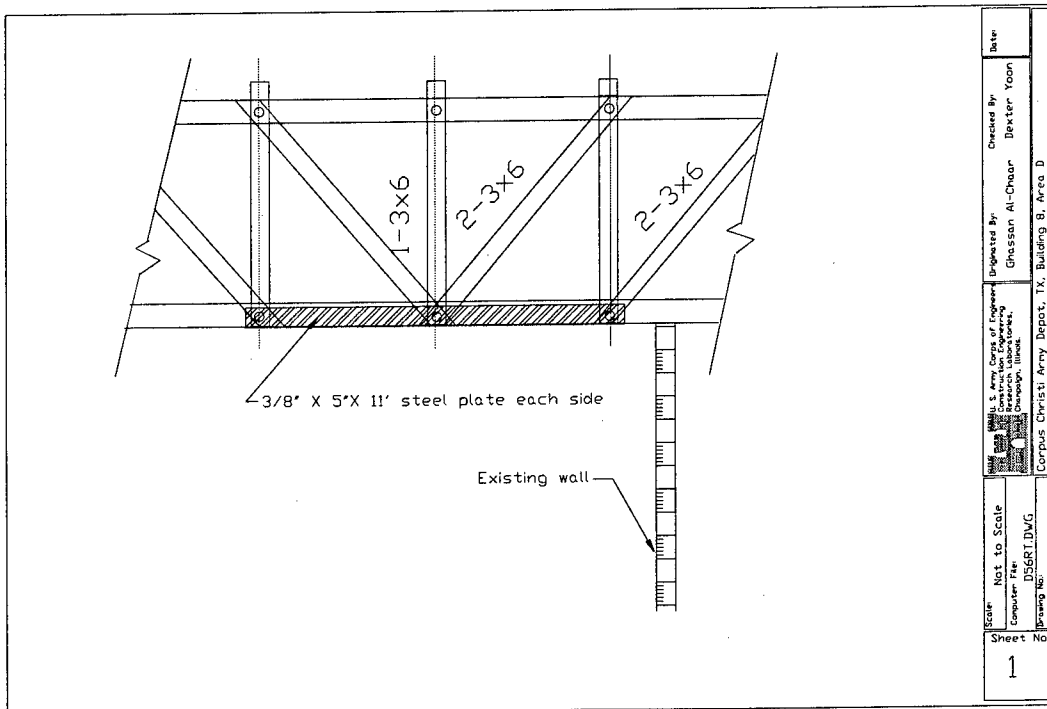

Figure I16. Proposed repair for Member TR in Truss Column Line 56, Area D.

USACERL DISTRIBUTION

Chief of Engineers

ATTN: CEHEC-IM-LH (2)
 ATTN: CEHEC-IM-LP (2)
 ATTN: CECG
 ATTN: CECC-P
 ATTN: CECC-R
 ATTN: CECW
 ATTN: CECW-O
 ATTN: CECW-P
 ATTN: CECW-PR
 ATTN: CEMP
 ATTN: CEMP-ET
 ATTN: CEMP-C
 ATTN: CEMP-M
 ATTN: CEMP-R
 ATTN: CERD-C
 ATTN: CERD-ZA
 ATTN: CERD-L
 ATTN: CERD-M (2)

ACS(IM) 22060
 ATTN: DAIM-FDP

Tennessee Valley Authority
 ATTN: WT 9D-K (2)

CEISC 22310-3862
 ATTN: CEISC-E
 ATTN: CEISC-FT
 ATTN: CEISC-ZC

US Army Engr District
 ATTN: Library (42)

US Army Engr Division
 ATTN: Library (8)

US Army Engineering and Support Center
 ATTN: CEHND 35807-4301

US Army Europe
 ATTN: AEAEN-EH 09014
 ATTN: AEAEN-ODCS 09014

US Army Materiel Command (AMC)
 Alexandria, VA 22333-0001
 ATTN: AMCEN-F

FORSCOM
 Forts Gillem & McPherson 30330
 ATTN: FCEN

TRADOC
 Fort Monroe 23651
 ATTN: ATBO-G

Fort Belvoir 22060
 ATTN: CETEC-IM-T
 ATTN: Water Resources Support Ctr

USA Natick RD&E Center 01760
 ATTN: STRNC-DT
 ATTN: AMSSC-S-IMI

CEWES 39180
 ATTN: Library
 CETEC 22315
 ATTN: Library
 CECRL 03755
 ATTN: Library

Defense Nuclear Agency
 ATTN: NADS 20305

Defense Logistics Agency
 ATTN: MMBIR 22060-6221

National Guard Bureau 20310
 ATTN: NGB-ARI

Naval Facilities Engr Command
 ATTN: Facilities Engr Command (8)
 ATTN: Engrg Field Divisions (10)
 ATTN: Engrg Field Activities (4)
 ATTN: Public Works Center (8)
 ATTN: Naval Constr Battalion Ctr 93043
 ATTN: Naval Facil. Engr. Service Ctr 93043-4328

8th US Army Korea
 ATTN: DPW (11)

US Army MEDCOM
 ATTN: MCFA 78234-6000

American Public Works Assoc. 64104-1806

US Army CHPPM
 ATTN: MCHB-DE 21010

US Gov't Printing Office 20401
 ATTN: Rec Sec/Deposit Sec (2)

Nat'l Institute of Standards & Tech
 ATTN: Library 20899

Defense General Supply Center
 ATTN: DGSC-WI 23297-5000

Defense Supply Center Columbus
 ATTN: DSCC-WI 43216-5000

Defense Tech Info Center 22060-6218
 ATTN: DTIC-O (2)

Corpus Christi Army Depot, TX 78419-5260 (10)

156
 07/98