

234163

JPRS-CST-85-020

24 June 1985

China Report

SCIENCE AND TECHNOLOGY

DTIC QUALITY INSPECTED 4

DISTRIBUTION STATEMENT A
Approved for Public Release
Distribution Unlimited

1 9 9 9 0 4 1 4 0 6 0

FBIS FOREIGN BROADCAST INFORMATION SERVICE

REPRODUCED BY
NATIONAL TECHNICAL
INFORMATION SERVICE
U.S. DEPARTMENT OF COMMERCE
SPRINGFIELD, VA. 22161

2
198
A99

NOTE

JPRS publications contain information primarily from foreign newspapers, periodicals and books, but also from news agency transmissions and broadcasts. Materials from foreign-language sources are translated; those from English-language sources are transcribed or reprinted, with the original phrasing and other characteristics retained.

Headlines, editorial reports, and material enclosed in brackets [] are supplied by JPRS. Processing indicators such as [Text] or [Excerpt] in the first line of each item, or following the last line of a brief, indicate how the original information was processed. Where no processing indicator is given, the information was summarized or extracted.

Unfamiliar names rendered phonetically or transliterated are enclosed in parentheses. Words or names preceded by a question mark and enclosed in parentheses were not clear in the original but have been supplied as appropriate in context. Other unattributed parenthetical notes within the body of an item originate with the source. Times within items are as given by source.

The contents of this publication in no way represent the policies, views or attitudes of the U.S. Government.

PROCUREMENT OF PUBLICATIONS

JPRS publications may be ordered from the National Technical Information Service, Springfield, Virginia 22161. In ordering, it is recommended that the JPRS number, title, date and author, if applicable, of publication be cited.

Current JPRS publications are announced in Government Reports Announcements issued semi-monthly by the National Technical Information Service, and are listed in the Monthly Catalog of U.S. Government Publications issued by the Superintendent of Documents, U.S. Government Printing Office, Washington, D.C. 20402.

Correspondence pertaining to matters other than procurement may be addressed to Joint Publications Research Service, 1000 North Glebe Road, Arlington, Virginia 22201.

24 June 1985

CHINA REPORT

SCIENCE AND TECHNOLOGY

CONTENTS

PEOPLE'S REPUBLIC OF CHINA

NATIONAL DEVELOPMENTS

| | |
|--|----|
| Policy Issues in Science, Technology System Reform (Hu Ping; KEXUEXUE YU KEXUE JISHU GUANLI, No 2, 12 Feb 85)... | 1 |
| Systematic Science and Technology System Reform Explored (Li Anhuan, He Jicheng; KEXUEXUE YU KEXUE JISHU GUANLI, No 3, 12 Mar 85)..... | 3 |
| Continuing Education Under New Situation Discussed (Qin Yunzhong; KEXUEXUE YU KEXUE JISHU GUANLI, No 2, 12 Feb 85)..... | 9 |
| Integration of Scientific Research, Teaching in Colleges (Ren Tingshu; KEYAN GUANLI, No 3, 1984)..... | 14 |
| Reform of Standardization Work Discussed (ZHONGGUO BIAOZHUNHUA, No 1, 1985)..... | 21 |
| Development Plans for Science, Technology in Liaoning (Jiang Zhizheng; KEZHANLUE KEJI GUANLI, May 83)..... | 24 |
| Workers Use Computers in Shipbuilding Industry (XINHUA, 3 May 85)..... | 31 |
| Editorial Urges Increased Use of Computers (XINHUA, 10 May 85)..... | 33 |
| Chinese Newspapers May Use Domestically Made Typeset Computers (Li Xing; CHINA DAILY, 23 May 85)..... | 34 |

| | |
|--|----|
| New Chinese Character Microcomputer Nears Production (GUANGDONG KEJI BAO, 4 May 85)..... | 37 |
| Smart Terminal Handles Chinese Characters (Wu Huijin, Qu Zhihong; HAINAN RIBAO, 5 May 85)..... | 39 |
| Software Company Opens Branch in Chengdu (Gu Longyuan; SICHUAN RIBAO, 5 May 84)..... | 40 |
| Peripherals Company Produces Chinese Character Printer (Wang Xin; HUBEI RIBAO, 5 May 84)..... | 41 |
| Nanjing Plant Manufactures Microcomputers (Zhu Weiwei; XINHUA RIBAO, 18 Apr 84)..... | 43 |
| Specific Computer Popularization Applications Listed (Wei Runsheng; SHICHANG ZHOUBAO, 15 May 84)..... | 45 |
| Microprocessor Controlled Engine Testing Developed (BEIJING DIANZI BAO, 12 May 84)..... | 47 |
| New Seismology Research Fund Allocation System Explained (Chen Yong; KEXUEXUE YU KEXUE JISHU GUANLI, No 3, 12 Mar 85)..... | 48 |
| Expansion of Vocational High School Education Advocated (Wen Ke; RENMIN RIBAO, 28 Apr 85)..... | 52 |
| Improving International Scientific Research Cooperation Suggested (LIAOWANG, No 8, 25 Feb 85)..... | 54 |
| Briefs | |
| Operation for Research, Production, | 56 |
| Computer Leasing Begins | 56 |
| Marketing of Microcomputers | 57 |
| Microcomputer Station Established | 57 |
| Ningxia Chemical Plant | 57 |
| Computer Software Development | 58 |
| Tianjin Harbor Television System | 58 |

APPLIED SCIENCES

| | |
|--|----|
| Preliminary Experimental Results of CT-6B Tokamak Heating Field Voltage Feedback Control (Zheng Shaobai, Shen Zhongqing; KEXUE TONGBAO, No 12, 1984)..... | 59 |
| Scheme for High-Speed Real-Time DFT Operation for Radar Signal Processing (Su Yanguang, Shi Xingrong; DIANZI XUEBAO, No 1, Jan 84)..... | 65 |

| | |
|--|-----|
| On H Plane Dielectric Loading Theory for H Plane Ferrite Phase Shifter (Wen Junding; DIANZI XUEBAO, No 1, Jan 84)..... | 70 |
| Nation's Achievements in High Energy Physics Reviewed (Zhang Wenyu; GAONENG WULI, No 3, Sep 84)..... | 76 |
| Integrated Optics Developments Over Past Decade, Future Prospects (Yu Rongjin; ZHONGGUO JIGUANG, No 4, 20 Apr 85)..... | 90 |
| High-Pressure, High-Temperature Opposed Anvil Device Described (He Yi, et al.; WULI, No 1, Jan 85)..... | 96 |
| Application of Computers in Analytical Chemistry: Calculation of Optimum Acidity of Reaction Between Metal Ions and Organic Reagents in Solution (Zhang Sunwei, et al.; HANGZHOU DAXUE XUEBAO, No 1, Jan 85)..... | 100 |
| Improved Algorithm for Radar Real-Time Data Processing (Zhang Zhiben; DIANZI XUEBAO, No 1, Jan 85)..... | 105 |
| Real-Time Application of OEM Modular 16-Bit Microcomputer System (Ye Shixun, Xu Zhigang; DIANLI XITONG ZIDONGHUA, No 1, Jan 85)..... | 109 |
| Chinese Character Output From TRS-80 Model I (Shu Kexin; XIAOXING WEIXING JISUANJI XITONG, No 4, 8 Apr 84)..... | 115 |
| Pulsed, Optically Pumped Gas-Mixture FIR Lasers (Pan Chengzhi, et al.; DIANZI XUEBAO, No 1, Jan 85)..... | 122 |

LIFE SCIENCES

| | |
|---|-----|
| Military Symposium on Microreconstructive Surgery Summarized (Zhu Shengxiu, Wang Huimin; JIEFANGJUN YIXUE ZAZHI, No 6, 20 Dec 84)..... | 126 |
|---|-----|

ENVIRONMENTAL QUALITY

| | |
|---|-----|
| Gearing Development of Environmental Science to Economic Construction (HUANJING KEXUE, No 4, 30 Apr 84)..... | 132 |
|---|-----|

ABSTRACTS

AUTOMATIC DATA PROCESSING

| | |
|---|-----|
| HANGZHOU DAXUE XUEBAO (ZIRAN KEXUE BAN) [JOURNAL OF HANGZHOU UNIVERSITY (NATURAL SCIENCES EDITION)] No 1, Jan 85..... | 138 |
|---|-----|

BIOCHEMISTRY

SHENGWU HUAXUE YU SHENGWU WULI JINZHAN [BIOCHEMISTRY AND BIOPHYSICS] No 6, Dec 84.....139

CHEMICAL PHYSICS

CUIHUA XUEBAO [JOURNAL OF CATALYSIS] No 4, Dec 84.....142

CHEMISTRY

HUAXUE SHIJIE [CHEMICAL WORLD] No 9, 20 Sep 84, No 10, 20 Oct 85...152

GAOFENZI TONGZUN [POLYMER COMMUNICATIONS] No 5, Oct 84.....154

ZHONGGUO XITU XUEBAO [JOURNAL OF THE CHINESE RARE EARTH SOCIETY] No 2, Nov 84.....159

HUAGONG XUEBAO [JOURNAL OF CHEMICAL INDUSTRY AND ENGINEERING (CHINA)] No 4, Dec 84.....160

COMMUNICATIONS

HANGZHOU DAXUE XUEBAO (ZIRAN KEXUE BAN) [JOURNAL OF HANGZHOU UNIVERSITY (NATURAL SCIENCES EDITION)] No 1, Jan 85.....166

COMPUTER SCIENCE

JISUANJI XUEBAO [CHINESE JOURNAL OF COMPUTERS] No 6, Nov 84.....167

ELECTRONICS

HANGZHOU DAXUE XUEBAO (ZIRAN KEXUE BAN) [JOURNAL OF HANGZHOU UNIVERSITY (NATURAL SCIENCES EDITION)] No 1, Jan 85.....176

DIANZI KEXUE XUEKAN [JOURNAL OF ELECTRONICS] No 2, Mar 85.....177

PETROCHEMICAL INDUSTRY

HUAXUE SHIJIE [CHEMICAL WORLD] No 9, 20 Sep 85.....182

MICROBIOLOGY

WEISHENGWUXUE TONGBAO [MICROBIOLOGY] No 3, Jun 84.....183

WEISHENGWUXUE TONGBAO [MICROBIOLOGY] No 6, Dec 84.....187

MICROCOMPUTER

WEIJISUANJI YINGYONG [MICROCOMPUTER APPLICATIONS] No 1, Jan 85.....189

TAIWAN

Briefs

DRAM Wafer Development
64K CMOS EPROM Chip

191

NATIONAL DEVELOPMENTS

POLICY ISSUES IN SCIENCE, TECHNOLOGY SYSTEM REFORM

Tianjin KEXUEXUE YU KEXUE JISHU GUANLI [SCIENTIOLOGY AND MANAGEMENT OF
SCIENCE AND TECHNOLOGY] in Chinese No 2, 12 Feb 85 p 2

[Article by Hu Ping [5170 1627]]

[Text] The issue of science and technology system reform is brewing and starting to be written about. A basic idea of the reform is to combine science and technology with economics in order to commercialize technology and to devote major efforts to developing technical market. Research institutes, whose major activity is research and development, ought to be put under a lower administrative level to revive and enhance their autonomy. At present, research institutes belong to individual departments. If they stay where they are, they are still owned and administered by departments and there will be no chance for revival. The only way to revive research institutes is by separating politics from research, gearing research institutes to the need of the society and carrying out socialization. The separation will solve many long-standing problems and problem of existing barriers between departments at different levels. There are different research institutes, some do basic research, others do applied research, and still others developmental research. One can not administer all of them in the same manner. For some basic research institutes such as high-energy physics, funds should continue to be supplied for them to continue their basic research whether or not they are put under a lower administrative level. But the system of funding should be adopted in which proposals are submitted that are to be completed in a few years and be subjected to peer review. If the results are not satisfactory, next time one will get no research project. Part of the applied research can be categorized as basic application, for which the system of funding perhaps should also be adopted. But for the part that is developmental in nature and will lead immediately to products, funding through royalty agreement should be used and they should be geared toward the need of economy to serve directly, through supplying technologies, the economic construction of the society and to carry out integration of technology and the economy. There are many ways to integrate. For example, some institutes are high-caliber ones and possess high-technology know-how. Are they allowed to set up their own plants to manufacture products? In the past, the answer was no because by doing so their goals would be twisted and one would not be doing scientific research but doing production instead. However, this is quite

common abroad. A few experts gather together, produce a new plan and immediately develop new products. They make big profits and become rich. After several years, mass production becomes reality. Why those engaged in research are not allowed to engage in production and enterprise in China? After all, the state wants us to serve the economy. Those without pilot-plant-scale capability can set up joint venture with factories. I provide technology and brain-power, and you provide plant and equipment. We get together and develop new products and we both benefit. This form of alliance and coordination is rather important. In short, technology and economy ought to be integrated.

In science and technology reform, the way of planning also has to be changed. In the past, science and technology plans drawn up were heavily infused with formalism. From now on, science and technology plans are to be divided into several categories. One category is command plan like the 5-year economic plan. The number of key problems that are to be tackled shall be determined and scientific research, design, pilot-plant test, and production shall all be included in the plan. Funds will be released all at once. One can pool them together and use them more efficiently. The other plans can be guidance-style, depending on which areas China wants to develop, which areas China has advantages, and what technologies need to be developed in the future. There will be no funding for this part. Rather than using the command plan measures, the state, through tax-deductions and tax-exemptions, low-interest and no-interest loans, and through regulating by economic leverage, makes some research profitable and one will have incentive to study. There is also a part that needs no plan at all, not even a guidance plan. For departments and areas, they determine what to develop based on their own strength and need. The state will give no assignments and you are totally on your own and totally regulated by market mechanism. By doing these, the whole scientific research becomes very flexible. Lateral connections will greatly be strengthened and the planning system changed. And the way of tackling problems will also change accordingly. Recently, the State Council criticized the Scientific and Technological Commission for not being imaginative. It is necessary to change the guiding principles of the Commission. It shall no longer spend great efforts in detailed, specific works. Rather, it shall pull together resources to deal with the macroscopic, important problems, understand the overall situation of scientific and technological development, study the major problems such as how to formulate principles, how to make policies, how to draw up plans, and how to make legislations, but shall not get involved directly in deciding how to tackle problems. For example, farmers urgently need science and technology. Who should be in charge? There is a need for a powerful policy to guide the management of science and technology in villages and mountain areas. Our comrades responsible for policy-making may make mistakes in certain specific tasks, but do not be handicapped because of this. They ought to be bold and initiative to study new situations and solve new problems. Then, our science and technology system reform is likely to travel on a road that leads to success.

12922

CSO: 4008/311

NATIONAL DEVELOPMENTS

SYSTEMATIC SCIENCE AND TECHNOLOGY SYSTEM REFORM EXPLORED

Tianjin KEXUEXUE YU KEXUE JISHU GUANLI [SCIENTIOLOGY AND MANAGEMENT OF SCIENCE AND TECHNOLOGY] in Chinese No 3, 12 Mar 85 pp 16-18

[Article by Li Anhuan [2621 1344 2719] and He Jicheng [0149 0679 2052] of the Shanxi Science and Technology Commission: "An Exploration of the Systematic Reform of the Science and Technology System"; responsible editor: You Siyi [3266 1835 1837]]

[Text] Along with thorough economic system reform, science and technology [S&T] system reform is becoming a strategic task which urgently needs to be carried out.

The S&T system is an organic and vigorous systemic entity formed of many interrelated and interacting key elements. In order to carry out a systematic reform of the S&T system, it will first be necessary to learn which key elements form it and how they interrelate and interact. A system of organization is a system of organizational installations, management jurisdictions and work plans concerning national organs, enterprises and business units. In this sense, the overall S&T system is formed of the following three basic systems: the scientific research system, the S&T management system and the regulatory system which enables the first two to play a cooperative role. The major goals of scientific research system reform are to eradicate the big-pot approach to scientific research organizations and to increase the vigor of research and development (R&D) organizations; the major goals of S&T management system reform are to eradicate the situation whereby research organizations eat out of the state's big pot, to change the condition of S&T being divorced from production and economic construction and to establish a S&T system which is full of life and suited to the economic system; and those of regulatory system reform are to coordinate relations effectively and flexibly between the scientific research and S&T management systems through formulating policies, plans and legislation and making technical circulation links. Only with the coordinated matching and synchronized carrying out of the reform of these three basic systems can the general goal of comprehensively and systematically reforming the S&T system be realized; this will enable the two-way role of S&T which is geared to the needs of economic construction and of economic construction which relies on S&T to be constantly strengthened and the proportion of technical progress in economic development to be continuously increased.

Scientific Research System Reform

S&T activity must be restricted by both S&T development laws and economic laws, and doing a good job of scientific research system reform must begin with an analysis of the specific characteristics of S&T activity.

A crucial problem in China's present scientific research system is that the "two accounts" for S&T plans and economic plans result in two covering for scientific research and the economy and that R&D work is not regarded as an indispensable part of economic development but as a separate cause which exists independently of the economy. Research institutes receive funds from the state year after year but do not assume a specific economic responsibility to the state, and the sources and amounts of their funds are unrelated to their work results; thus, research organizations are not subject to economic pressure and impetus and lack an inherent vitality for continuous progress. S&T system reform must master this crucial problem in order to be able to operate from a strategically advantageous position with irresistible force.

What specific forms directly link the quality of research institute work with the scientific researchers' pay? Many experimental reform units have provided successful experience in carrying out personnel hiring and problem contract job responsibility systems in research institutes. A problem that demands a prompt solution in present scientific research organization microcosmic reform is how to develop the role of the law of value in the process of producing, circulating and using technical products. Only by solving a series of specific scientific research economics problems can the implementation of an R&D economic job responsibility system have a reliable basis and rules to follow and be able to link the quality of research institute microcosmic management with the immediate interests of staff members and workers and fully arouse the enthusiasm, initiative and creativity of scientists and technicians.

In order to enable the enthusiasm, initiative and creativity of scientists and technicians to be fully developed, it will be necessary to enable researchers to have a definite degree of autonomy. But in order to achieve this, the autonomy of research institutes must be expanded. Thus, the present S&T planned management and fund management systems must be reformed. It is quite clear that if plans are formulated and funds appropriated by the higher authorities, the quality of research institute work will to a large degree not be determined by the research institutes themselves but by the higher-level management departments, and research institutes will in fact still have no autonomy. The research institutes' inherent vitality is interconnected with their relatively independence. It is impossible to require only vitality and not give autonomy. Only by expanding autonomy can extensive horizontal links be established between research institutes, between research institutes and colleges and universities and between research institutes and production enterprises, the barriers between departments and regions be broken and an R&D network coordinated with economic construction be formed.

Regulatory System Reform

Increasing the vitality of R&D organizations and fully arousing the enthusiasm, initiative and creativity of scientists and technicians are the focus of S&T system reform. But in the age of "going all out for science," the scope and difficulties of R&D have been progressively increasing. How to raise R&D efficiency, control and coordinate the R&D process, combine as much as possible the orientation of S&T exploration with social needs and revise the structure of research orientation and technological development based on social needs are key problems in S&T system reform. This will require the establishment of a perfect regulatory system that enables the state to control effectively the microcosmic activity of R&D organizations through guided macroscopic planning.

A disadvantage of the present S&T system is that it only uses the regulatory measure of directed planning. How can we enable R&D organizations to have the essential autonomy while not losing overall control? Through comparison with economic system reform, it can be seen that S&T system reform must establish a flexible regulatory system coordinating macroscopic and microcosmic relations. To this end, the regulatory system which we need should include many regulation patterns. Judged from the overall viewpoint, one is direct regulation through planning and another is development of a technology market, establishment of a technology bank and indirect control over R&D organizations.

Direct regulation through planning, direct issuing of directed plans by the state and direct stipulation of the research tasks of research institutes are essential in concentrating manpower and material and financial resources and in completing scientific R&D projects which have important significance for developing the national economy. But the present planned management must be reformed and directed scientific research plans must be guided by S&T development predictions and plans. It will be necessary to rely mainly on S&T policy, legislation and funds for R&D organizations being controlled from outside and not on administrative interference from within.

As for tens of thousands of technical problems in developing production and the economy, the state cannot and does not need to stipulate the research directions and problems of each research institute, but R&D organizations should make their own plans based on social needs; establishing a "free scientific research" system, developing a technology market and dredging technical circulation channels will directly solve problems of technical production needs between R&D organizations and units which use technology. Through the regulatory role of a technology market, we can solve the problem, which was not solved well in the past, of S&T needing to be geared to the needs of economic construction and of economic construction needing to rely on S&T. Developing a technology market will basically result in a new lease on life for China's S&T: many scientists and technicians will be more conscientiously geared to the needs of economic construction and strive to study how to solve the widest range of technical production problems; many technical results will break through regional, departmental

and unit blockades and be more quickly applied to production and construction practice. Since they will be geared to the needs of society and the market, scientists and technicians will be able to exchange their scientific research results without necessarily having to transfer to other posts, the principle of distribution according to work will be further implemented and all enterprises and production units will be able to obtain the technology they need from the technology market. In summary, opening a socialist technology market and carrying out market regulation of the S&T R&D process are inevitable results of having developed a socialist commodity economy and will inevitably promote the development of coordination between China's S&T and our economy and society.

In order to realize the regulatory mechanism of a technology market, an S&T development bank should be established as quickly as possible. An S&T development bank will not only be able to coordinate economic relations between scientific research units (technology-producing units) and between scientific research and production units (technology producers and users) but will also be able to play a supervisory and arbitration role in the R&D process. The S&T system is regarded as an independent field of knowledge production which has the same general characteristics as industrial and agricultural production activity and also its own distinct characteristics, and the fund turnover in the R&D process in particular has a distinct style of movement. An S&T development bank will not only be able to utilize economic levers fully, improve the fund utilization rate and discover and control nonessential duplicate problems, but based on the condition of fund movement in scientific research units, it will also be able to determine fair transfer prices for scientific research results and developed technology. Since this regulatory system of directed planning, a technology market and a technology bank takes into account vertical relations, it will ensure that research organizations concentrate their forces on giving priority to undertaking state-assigned key scientific research and technical development tasks, giving research organizations autonomy and opening channels and places for the development of horizontal technical service; moreover, the technology bank regulating the key link of S&T funds will ensure coordination between macroscopic S&T management and microcosmic R&D systems.

Macroscopic S&T Management System Reform

The goal of establishing a powerful regulatory system is to enable the R&D organizations to be invigorated microcosmically and, based on unified planning and directions, to carry out purposeful and orderly macroscopic scientific research. In order to achieve this, a macroscopic S&T management system which strengthens China must first be established through reform. China's macroscopic S&T management system has not yet formed a perfect and stable structure, and while definite links exist outwardly between the national science commission and the provincial science commissions and between the provincial science commissions and the local and county science commissions, these are in fact "empty" links: except for "project" and "fund" contacts between higher and lower levels, vertical professional work and systematic construction links are

still not very close. Macroscopic systematic management is not in a controlling and closed-type management condition but is in an uncontrolled or runaway, open-type management condition. All basic-level science commissions operate under these conditions and problems have appeared in varying degrees such as organizations being unsound, duties being unclear, functions and powers being different and management specialization, systematization and standardization being unrealized, thus seriously blocking the development of the functions and roles of S&T management departments at all levels. Practice in the present S&T system reform must enable macroscopic S&T management system reform and microcosmic R&D organization reform to be synchronized, to do a conscientious job of establishing S&T management organizations and to establish an effective S&T management system throughout China which has clear administrative levels, clearly demarcated duties, a rational division of labor, links from beginning to end, vertical and horizontal links and easy-to-handle directions in order to raise management efficiency and promote the development of S&T.

Second, a macroscopic S&T development policy-making economic job responsibility system must be established. In S&T development policy making, certain irresponsible blind directions and faulty policy decisions relying on the wishes of senior officials often appear. The reasons for this cannot only be looked for in individual ideology and style but should also be looked for in the system. A mistaken policy decision or an improper plan will often create losses which are difficult to remedy, but the policymaker himself may refuse to accept any economic responsibility. Thus, S&T system reform must not only establish an economic job responsibility system in which research institutes are responsible to the state through external fulfillment of contracts and scientific researchers are responsible to research institutes through internal problem contracts, but they should also carry out one for S&T management department policy making and link policy decisions and their results with the policy makers' economic results.

Third, the functional and organizational structures of S&T management departments must be reformed and organizations which provide information to policymaking levels must be strengthened. The building of an S&T management information system must be strengthened and a complete information work system be formulated. Our S&T management departments at all levels are not set up according to the needs of the centralized state power type of management system, their functions and organization are mainly realized through administrative orders and this will make it difficult to adapt to the needs of the new scientific research system after scientific research organizations are invigorated microcosmically and a technology market is opened. Thus, macroscopic S&T management must simplify administration and expand authority level by level, extricate itself from the past "monopoly" science commissions into organizations which under take to do a good job of macroscopic S&T development policy making in order to realize the general goal of technical development and decision making on formulating policies, laws and regulations as their basic functions, and conscientiously study how to formulate examination norms and methods for and fully develop the functions and roles of S&T management departments at all levels.

In summary, reform of the microcosmic R&D system, the macroscopic S&T management system and the regulatory system must keep in step; reforming only one of them would cause their interrelated key elements to be unable to promote and cooperate with each other and the S&T system to lose its overall balance.

12267

CSO: 4008/323

NATIONAL DEVELOPMENTS

CONTINUING EDUCATION UNDER NEW SITUATION DISCUSSED

Tianjin KEXUEXUE YU KEXUE JISHU GUANLI [SCIENTIOLOGY AND MANAGEMENT OF
SCIENCE AND TECHNOLOGY] in Chinese No 2, 12 Feb 85 pp 17-18

[Article by Qin Yunzhong [4440 6663 0022]]

[Text] Editor's note: The challenge of new technological revolution and the new situation of urban economic system reform dictate that more emphasis be put on the development of intellectual resources, that the training of qualified personnel be intensified, and that the quality of those cadres involved in science and technology be raised. Higher requirements are thus placed on the continuing education for cadres involved in science and technology at their post. In this article, a few problems currently existing in continuing education were analyzed and preliminary proposals for correcting the situation were put forward.

1. Where Are the Problems in Our Current Continuing Education?

Reform and new technological revolution have created urgent and heavy tasks for our continuing education. To accomplish them, we can not avoid examining current problems in this undertaking and finding out crucial reasons for not adjusting to the needs of the new situation so that new developments can be pursued. Although continuing education does not have a long history in our country, it is certain that it is accepted by more and more people and has achieved certain degree of progress. Meanwhile, problems exist in many areas.

(1) The importance of continuing education for scientific and technical personnel is only understood by high-level leaders and a few middle- and low-level leaders. The majority of leaders have little understanding. As a result, continuing education has not been placed on high priority. The major manifestations are as follows: On the aspect of understanding, there still exists the old notion that "there is no need to learn any more after college." For example, one professional of a certain organization in Tianjin asked supervisor for attending in-service training. This supervisor replied: "You already graduated from college, what more do you want to learn? Give the opportunity to those without formal education." Other leaders tend to think of in-service study of scientific and technical personnel as conflicting with work, and even regard learning as personal business and consider as

illegitimate the acquiring of scientific and technical knowledge during working hours. On the aspect of reform system, the rules and regulations regarding the continuing education for scientific and technical personnel are lacking and there is no guarantee as to the sites and funds for continuing education and the study time for scientific and technical personnel. On the aspect of administrative system, the majority of prefectures, counties, bureaus, and grass-root units have dedicated no organization or personnel to continuing education.

(2) In our current continuing education for scientific and technical personnel, there is a serious problem of following the format of "carry on education", i.e. the format of formal education. Its principal manifestations are that there are lots of systematic class-room lectures but little practical training, lots of long-term training requiring release from production but little short-term training, plenty of education that lead to diploma but little single-topic training. This is due to the lack of understanding to the fact that the on-the-job education for scientific and technical personnel, particularly those with college degree, has the basic characteristics of selectivity dictated by "learning whatever the job requires."

(3) The courses offered in continuing education are not advanced and the educational standard is low. Take for example the 54 workers colleges in Tianjin. The majority of the special topic courses are old-fashioned, only very few have to do with the new technological revolution. The Tianjin Advanced Study College of Science and Technology, which takes up the responsibility of serving as base for the advanced study of Tianjin's middle-level core members of science and technology, has offered advanced courses in systems engineering, computer and some modern technologies. However, the number of people trained is few and major efforts are still spent on the single-subject training classes on traditional specialties.

(4) There are still roadblocks in implementing continuing education. Institutes of higher learning and scientific research organizations, having the advantages in terms of knowledge and talents and great potential, are not really committed and have only contributed insignificantly. In particular, research organizations have not realized that the continuing education for scientific and technical personnel is a social responsibility they have to shoulder.

(5) Within a scientific and technical team, the opportunity to get continuing education is not equal. The core members have heavy responsibilities with many meetings and administrative affairs to take care of and have little time left for study. On the other hand, mediocre workers and those with few assignments get many opportunities to be released from production to study. As a result, the knowledge level of core members becomes lower and lower while non-core members do not get the challenges of practical scientific and technical tasks.

The existence of above-mentioned problems exemplifies that our continuing education is still in its infancy and is not adjusting to the needs of the new situation. It urgently needs to be strengthened and perfected.

2. A Few Propositions to Opening up A New Prospect for The Continuing Education.

(1) The basics of continuing education, including the following areas, have to be strengthened.

a. The administrative departments of all levels of scientific and technical cadres ought to dedicate organization or personnel to managing the continuing education for scientific and technical personnel as an important function of these departments. Meanwhile, higher level departments have the responsibilities of examining, guiding, supervising, and evaluating the lower level departments' handling of this task so that an operable management system will evolve.

b. Laws and regulations for continuing education ought to be formulated and issued, rules of continuing education be established and amplified, and the legal function of rules and regulations be brought into play in order to assure that continuing education becomes an important part of education and to facilitate the arousal of enthusiasm of the massive scientific and technical personnel to on-the-job training and study. For these purposes, it ought to be clearly stipulated in the laws and regulations that on-the-job training and study is the inalienable right of every scientific and technical personnel. The evaluation of continuing education for scientific and technical personnel at such organizations as enterprise, scientific research and planning ought to be linked to the evaluation of "six good enterprise" and the economic benefit of the organization. The content of continuing education should also include the evaluation and promotion of cadres. Those who fail to meet the requirements of advanced study and training will be promoted slowly or not at all or even demoted.

c. The continuing education bases and a system under which colleges and scientific research organizations are open to the society ought to be established, the enthusiasm of running school and the advantage of pooling knowledge from all sorts of societies, associations, democratic parties and mass organizations be given full play so that a multi-level, multi-standard network of continuing education will take shape.

(2) Special measures ought to be taken to accelerate the education and training of all kinds of high-level scientific and technical talents and outstanding young scientific and technical talents.

The driving force that constantly pushes forward our science and technology as well as economic constructions is the sufficient number of energetic, high-level scientific and technical teams. However, our current high-level scientific and technical teams are aging and outdated in knowledge. For example, 95 percent of the over 500 senior engineers in Tianjin are old-aged, some already retired and others have reached retiring age. They are no

longer able to do what they want to and desperately need to be replaced with new people. We must hasten the pace of training high-level talents by adopting special measures.

a. Central and local authorities ought to set up continuing education bases for training all kind of high-level talents, select middle-aged and young scientific and technical personnel with potential and intensify their training.

b. Different channels ought to be opened up so that more middle-aged and young scientific and technical personnel are selected to study abroad and technological cooperation with foreign countries is carried out.

c. Domestic and foreign experts ought to be invited to give different training courses in modern science and technology and give special-topic lectures.

d. Thought ought to be freed and some unnecessary restraints be broken, and more funds be allocated in order for more scientific and technical core members to attend international academic meetings, in the same manner atheletic teams are sent to participate in international competitions, so that they understand and grasp the situation and trend of world scientific and technological developments.

(3) The formats and methodologies of continuing education that meet the requirements of scientific and technological as well as economic developments and fit the characteristics of education for scientific and technical personnel ought to be explored and adopted in order to quickly change the current situation of following the formats and methodologies of formal education.

a. Self-study ought to be vigorously promoted and self-study front be opened up, and the material and facilities necessary for self-study be supplied so that self-study becomes a major form of continuing education for scientific and technical personnel, especially the middle- and high-level ones. This is because the continuing education for in-service scientific and technical personnel has strong objective and is highly selective in the content of study. It is not quite compatible with systematic class-room education. In general, adults are highly-independent and are able to absorb by themselves whatever they need to. The systematic class-room education is not compatible with the independent mentality scientific and technical personnel show in their training and study.

b. Continuing education ought to be diversified, multi-standard and multi-level in order to accommodate different learning purposes, different learning abilities, and different choices of scientific and technical personnel, and for them to be able to shift freely within the flexible and diversified continuing education system. Individual area has to gradually establish a better continuing education system based on the analysis of each area's make up of scientific and technical team members.

c. Various types of continuing education ought to be operated in close coordination with the practical needs of scientific and technical as well as economic tasks. People are trained for whatever specialties needed. The training education ought to cover the areas of enterprise technological transformation, technology acquisition, technical problem-solving, and computer promotion so that the continuing education has impact on solving practical problems.

d. Special attention ought to be paid to explore the formats and methodologies of continuing education that are suitable for the needs arising from the situation of economic system reform and science and technology system reform. There is a common measure in all reforms, that is carrying out responsibility system and "reward by merit." This certainly will arouse the learning enthusiasm of massive scientific and technical personnel. It also suggests to us that continuing education has to be more flexible and selective in terms of schedule and format. For example, in terms of study schedule, night schools, trade schools and morning schools are probably more suitable to the needs of the situation, and in terms of content of study, single-topic training and short-term training courses are probably more suitable than long-term courses with systematic lectures. Emphasizing the development and training of ability is more attractive than the education of pure theoretical knowledge.

All kinds of unexpected problems will certainly emerge with the development of reform situation. We ought to actively study various situations accompanying the development, to make great efforts to explore compatible patterns, educational formats, means, and methodologies of continuing education, and to turn continuing education into an important education that enhances the four modernizations construction and meets the challenges of new world technological revolution.

12922

GSO: 4008/311

NATIONAL DEVELOPMENTS

INTEGRATION OF SCIENTIFIC RESEARCH, TEACHING IN COLLEGES

Beijing KEYAN GUANLI [SCIENCE RESEARCH MANAGEMENT] in Chinese No 3, 1984
pp 70-73

[Article by Ren Tingshu [0117 1694 2873] of Chong ing University: "A Discussion on the Integration of Scientific Research and Teaching in Institutes of Higher Learning"]

[Text] In the development of our scientific undertaking, the institutes of higher learning carry a double responsibility of educating able people and developing scientific technology. The institutes of higher learning should not only be a center of education but also a center of scientific research. Both teaching and scientific research are the basic responsibilities of the institutes of higher learning. The integration of scientific research and teaching thus becomes an important characteristic in the development of scientific research in the institutes of higher learning in this article, based on the actual experience of the development of scientific research in our University, we will discuss what we have learned from the practice of integration of scientific research and teaching.

To Educate Able People with High Quality is the Integration Point of the Duties of Scientific Research and Teaching

The main purpose of the "two centers" of the key institute of higher learning is to produce able people with high quality (and at the same time to produce high level research results). The scientific research in the institute of higher learning should be at the service not only of the reconstruction of socialism, but also of the education of able people with high quality. The duty of scientific research and that of teaching are thus united. Usually, people only see the effect of teaching on the production of able people, yet do not pay attention to the effect of scientific research on the production of able people. The effects of development of scientific research on the production of able people are described as follows:

(1) The renewal of the content of courses and the setup of higher level special topics courses or elective courses need scientific research as their foundation.

Only through the modern scientific and technical research, can the institutes of higher learning (especially colleges of science and engineering)

continuously renew their teaching material to adjust the needs of the four modernizations, raise the starting point of their teaching and produce able people of high quality. For example, recently the teaching and research laboratory of mechanics in our university has been actively pursuing research in finite element methods, fracture mechanics, laser bombardment, and mechanical vibration. We not only obtained research results, but also renewed the content of our courses. The new courses we offered are fracture mechanics, experimental mechanics, finite element method and vibration theory. Thus we raised the level of our fundamental mechanics courses, produced 29 graduate students and set up a new field of practical mechanics. And the new courses such as computer diagnostics and debugging techniques, the developmental characteristics of machine tools, the vibration of the automobile, the high speed processes in electrical engineering and in the new fields such as hi-tech electronics, automobile, computer software, metallurgy in our university are all built on the foundation of scientific research. In recent years, our university has offered 120 new courses, set up 11 new fields and produced 69 graduate students. And all of these accomplishments can not be separated from our active development of scientific research.

(2) Intellectual development ususally requires the process of scientific research

Following the swift progress of modern science, the volume of knowledge increases rapidly. From the estimation of a specialist abroad, if a scientist works day and night, he can only cover 5 percent of the publications of the world in his field. Thus, a college or graduate student although studying with all his might can only obtain a basic knowledge from the university. As for students in technical institutes of higher learning, his intellectual development mainly includes the development of an ability for self-learning an ability to do research, and ability to perform independent tasks and an ability for organization and management. The development of these capabilities usually can not be achieved unless one has undertaken scientific research. The lower grade students can participate in extracurriculum scientific activities and the higher grade and graduate students should directly undertake a scientific research task under the guidance of advisors. For example, among the 50 senior theses (designs) of the year 1977 in the teaching and research laboratory of machine tools in our university, 23 of them were bases on their scientific research. The striking effects on the intellectual development of the students are as follows: 1. They were able to grasp the total process of practical problem solving from data collection to conclusion by using knowledge they learned in the university. 2. They learned the methodology of an experiment from its conception and design to its finish. 3. They developed an ability to analyze and research independently. The examples of the effects on intellectual development from the research theses of the graduate students will be even more numerous and more remarkable. These effects can hardly be achieved without scientific research.

(3) To raise the academic level of the faculty members we must do scientific research

A faculty with a high academic level is the basic condition in educating able people of high quality. Raising the academic level of faculty members can not

be accomplished by just studying books, literature and repeating the old lecture notes. One has to develop research in his field, connect finding problems, analyzing problems and solving problems together, obtain knowledge from practical life and investigate new ideas. By raising one's academic level, one can enrich his teaching material, Among the 105 associate and full professors promoted in recent years in our university, 80 (76 percent) of them have done scientific research and obtained research results. And among the 35 advisors of the current class of graduate students, 32 (91 percent) have definite research results, thus they have produced graduate students with higher quality. The effect of scientific research on the raising of the academic level of faculty members is very obvious.

The Development of Applied Basic Research is the Integrating Point of the Content of Scientific Research and Teaching

Basic research, applied research and developmental research are the three basic constituents in the system of scientific research in all the fields. They are also the three phases in the developmental process of any scientific technology. Early in the 1950's, comrade Zhou Enlai [6650 1869 0171] already pointed out that the scientific research in institutes of higher learning should be both basic and applied research. This not only indicated the area of emphasis in the scientific research in the institutes of higher learning, but also revealed the connection between scientific research and teaching in the institutes of higher learning. Proceeding from the actual conditions of technical institutes to develop applied basic research is to set up a large amount of practical technical research, from picking the topic to planning, centered on the real production technical problems (match with the special fields in the institutes) in the national economy. At the same time, we should offer the basic research topics that are related to the practical problems. This research should agree with the following principles.

First, following the law of scientific and technical development, confirming the policy of our scientific and technical development. The three research phases--base, application and development, are also the three categories in scientific research. The proportion of the three in a society is not equal but should be coordinated. From the experiences of the technically developed countries abroad, it is more or less 1:6:9. The policy of our scientific and technical development also emphasizes applied and developmental research. But basic research is the research of principles and rules, it usually has a guiding and predicting effect, is indispensable; and it is also a source for applied research. Thus, while largely engaged in applied and developmental research, we should still pay attention to the corresponding applied basic research.

Second, following the teaching rules of institutes of higher learning, adjusting the conditions of the institutes of higher learning. The focal point of the teaching material of the institutes of higher learning is basic theories, which include basic theories of applied technology (that is applied base). The characteristic of technical institutes is that most teaching material belongs to the technical field, that is in the field of applied base; and both

the scientific research projects developed for the purpose of teaching and the scientific accomplishments of the faculty members are mainly in the area of the applied base. Thus emphasizing the development of applied basic research can facilitate not only the promotion of applied and developmental research to serve the economic reconstruction, but also the introduction of the research results to the classroom, raising the level of teaching. Thus, is the integration of the content of the scientific research and that of teaching.

In the development of applied basic research, we should pay attention to the following:

(1) In choosing research topics, in addition to production needs, we should consider the teaching base, the ability of the faculty members and the actual situation. We have to choose subjects which can be adjusted to the fields and courses; have good teaching base, qualified teaching staffs and adequate equipment, and have a tendency to develop into a multidisciplinary comprehensive study. In short, it should be favorable to production. to getting results and to teaching. For example, the development of the research on the unit horse power single phase capacity electric motor and the high level magnetic separator in the research and teaching laboratory of electric engineering in our university, fitted into the conditions mentioned above, started very easily and progressed quite fast. Within 1 year, it accomplished two results and was judged as reaching to an advanced level in our country. The conclusion they obtained from this experience was: "The topic of research should be the one that can show our strong points and avoid our drawbacks, fit the needs of our country and develop our strong points."

(2) In the planning of scientific research, we have pay attention to the requirement of the integration with teaching. First, in the research material, especially on technical production problem, we should not just pay attention to the requirement of the finished products, the craft and the technology, but emphasize the corresponding applied basic research, such as the study of the mechanical theory of the new craft, the principle of the new technology and the improvement of the new method. This can both raise the level of the production technology fundamentally and further grasp and utilize the laws of nature, to raise our theoretical level and teaching level. For example, research in the production of the curved components, which won the second national invention prize, began from research to solve the production problem or a rectangular spline-slotting tool. Since attention was paid to the research of the corresponding basic theory, a new production method of curved components with more general meaning thus developed. This not only raised the level of the products, but enriched the teaching material. Second, in the arrangement of the research force, we should let the graduate and senior students participate as much as possible, even to make-up lessons if possible. The research projects of the majority of graduate students in our university are small topics of the research interest of their advisor's, and are centered on their advisor's research developments. Last year, to organize seniors to participate, the mechanical tool research laboratory in our university divided the research project of the dynamic and static states of machine tools into 9 small topics, arranged an extracurriculum scientific research activity for the students, even with some make-up lessons. After a year, the quality of graduating designs (senior

theses) was improved and the development of the research in that area progressed nicely. Third, in the experimental procedures of research, we have to consider their service in teaching. For example, the combination vibration test platform developed in the automobile teaching and research laboratory in our University not only solved the testing problem of a silicon oil vibration damping system but also satisfied the requirement for teaching testing functions. It produced 32 vibration experiments for teaching purposes.

(3) We have to pay attention to the summary and increase the results of scientific research and introduce them into our teaching to enrich our teaching material. The direct purpose of the result of scientific research, according to its social function, is to raise the scientific level and improve the development of production. But from the viewpoint of scientific research in institutes of higher learning, it must improve the teaching level. First, since the projects of scientific research are chosen to integrate into the needs and the conditions of teaching, it makes the results of research fit into teaching very easily. Second, the research projects of senior and graduate students mostly are derived from the basis of the research results of the faculty members. These are not only scientific research topics, but also a segment of the teaching process. Third, to pay attention to the summary and the increase of the results of applied basic research will facilitate the setting up of new courses and new fields. For example, the research and teaching laboratory of electric engineering in our university paid great attention to the research of the theory of electromagnetic fields and the technological theory of testing during their research of single phase electric motors, it thus offered three new courses--the design of single phase electric motors, the testing of electric motors and high speed processes in electrical engineering. During the study of the rotating vibration of automobiles, our teaching and research laboratory of automobiles paid a great deal of attention to the theory of vibration and its application research and thus offered two new courses--automobile vibration and the control and stability of automobiles. These all demonstrated the effect of the utilization of the results of applied basic research on raising the level of teaching.

The Practicality Teaching Link is the Integration Point of the Method of Scientific Research and Teaching

In technical institutes, the purpose of teaching of the teaching link of laboratory work, course design, production practice and thesis (design) is intellectual development of college and graduate students. And the scientific research processes have an outstanding effect on intellectual development. Thus, to combine scientific research and a practicality teaching link, we can achieve the goods results of educating people while at the same time obtaining research results. From this point of view, we can say that the practicality teaching link is the integration point of the method of scientific research and teaching.

Let us just look at the thesis, it is not only a teaching link with its strong emphasis on practicality and unification but also a scientific research project with strong emphasis on exploration and research. It has an important effect on systematizing and strengthening theoretical knowledge, developing

thinking and research and independent practical problem solving abilities. Thus, it is both a method of teaching and a form of scientific research. From practice, it is proven that if a thesis is well planned and organized with great earnest, it can integrate teaching and scientific research with remarkable effects.

(1) It improves the widespreading development of scientific research, makes the direction of key research subjects more outstanding. Among the 94 research items of our university in 1981, 52 of them (56 percent) were participated in by senior or graduate students in the form of thesis work. Thus, research projects were increased from 110 to 176 (an increase of 63 percent), and the research force was increased from 153 to 526 people (a more than three-fold increase). This obviously enlarged the research subjects and strengthened the research force. Most projects were well planned within the key subjects, thus strengthening the key research. Some of the key subjects usually lacking research people in the past, were strengthened through thesis work of graduate students. For example, seven graduate students were arranged to study the theory and application of mechanical vibration, and they obtained remarkable results. Among the seven theses, five of them were selected to participate in a national symposium. Their advisor said: "The graduate students accelerated my scientific research work, I could not finish these seven theses even in 10 years if I did them just by myself."

(2) It promotes the in depth development of scientific research and raises the research level. From practices, it was proven that the thesis which is integrated with scientific research can both enlarge and strengthen scientific research by faculty members and help their research develop in depth. For example, the theoretical and applied research of a setting technique of conical gears in our university was already quite distinguished. The thesis of a current graduating graduate student, "The Principle of Meshing Among Hyperboloid Gearwheels and Their Application in Gleson Spiral Gear Making," after the defense, was considered "not only reaching a definite theoretical level, but with more practical value," "an outstanding masters thesis." This result greatly deepened the research in this field. Another example is a senior thesis about "the calculation of probability networks". It was bases on his advisor's research result of "the reliability of electric system," "to develop a quick and reliable method of repeating calculation." The adviser thought his student gave him inspiration.

(3) It raised the quality of teaching and produced people with ability. The effect of these research theses on the systemization and strengthening of knowledge and intellectual development is remarkable. As to the quality of the theses of the 69 graduate students in our university in the past 2 years, all 58 of them who already defended their theses, passed their defense and obtained master degrees, For example, the thesis "About the New Model and Calculation of the Electromagnetic Transient Situation" was considered" its theory well-knit, its method advanced and having a distinctive opinion in the current electro-magnetic transient condition calculation," and the thesis "the Study of Several Methods for Increasing the Speed of Fast Fourier Transform" was considered "improving the speed of FFT, with important significance,"

and "from computer experiment proven with definite creativity." A senior thesis about "The Study of Super Fine Grinding of General Grinding Machines" was finished after the student investigated 15 factories, collected more than 200 pages of practical data, went through more than 10 testing ground experiments and obtained a result of product with grade 10 to 11 fineness from grade 9. Another senior did a thesis about "The Study of Wire Damage Calculation" for the electric network of Zigong City, and was considered by the power bureau of that city as "a great contribution to the development of theoretical calculation of damage and repair of electric wire networks".

Thus, integration of teaching and the development of scientific research is an important link for producing results and educating able people and also an advantage and characteristic of scientific research in institutes of higher learning.

12875

CSO: 4008/302

24 June 1985

NATIONAL DEVELOPMENTS

REFORM OF STANDARDIZATION WORK DISCUSSED

Beijing ZHONGGUO BIAOZHUNHUA [CHINA STANDARDIZATION] in Chinese No 1, 1985, pp 2-3

[Article by staff commentator: "Speed up the Reform of Standardization Work and Accelerate Technical Progress"]

[Text] Standardization is an important foundation of a technical economy. It runs through the entire process of scientific research, design, production, construction and distribution, and is an important means to summarize and promote technical accomplishments as well as to convert scientific technology to productivity. Since the founding of our government, especially after the 3d Plenary Session of the 11th CPC Central Committee, standardization in China began to make rapid progress due to the joint effort of all the workers in the field and with the concern of the CPC Central Committee and the State Council.

In the past 2 to 3 years, the number of standards formulated increased very rapidly. The level has also been improved. From 1982 to 1984, more than 1,000 national standards were drafted each year. Among the national standards written in 1982 and 1983, the number of international standards and advanced foreign standards adopted reached 25 and 30 percent, respectively. Among the national standard drafted from January to November 1984, 30.4 percent of them were written by adopting international and advanced foreign standards. In addition, 28.2 percent reached the world level in the 1970's and 1980's. In total, 58.6 percent of the standards reached an advanced level. In the area of product quality control, over 1,400 quality control stations and more than 140 product quality control offices were established, forming a preliminary national product quality control network. There has been new development in the training of standardization personnel. Jiaotong University in Xian accepted 26 double major undergraduate students last year. The Institute of Standardization Management Personnel of China was founded last October. It had already accepted 50 students to be trained in English conversation. More and more standardization and product quality control personnel are being trained. This indicates that the standardization work has progressed well in China.

In this year, it is an important task to speed up the reform of standardization to rapidly upgrade existing standards to the world level in the late 1970's and early 1980's, to promote technical progress, and to develop productivity in order to meet the requirements for economic reform. to realize the objectives

and strategy of the 12th Party Congress, and to carry out the spirit of the 3d Plenary Session of the 12th CPC Central Committee.

The reform of standardization should be done based on the principle of tight management from the overall prospective. As far as the specifics, it should be open and flexible, aiming at motivating all parties involved. One of the key point to reform is to alter the existing "mandatory" standardization system to promote some "non-mandatory" standards. To implement a "mandatory" standard does not favor any further improvement of the standard to promote technical advances. In the future, with the exception of some important fundamental standards, methods, and standards related to safety, hygiene, worker protection, environment protection, and certain industrial and agricultural products, most of the product standards will be transferred to the class of "non-mandatory" standards. Second, we shall reform our three level system and add a level as "local standards". China is a huge country. Technical levels differ widely from region to region. By adding "local standards," we can facilitate the utilization of local resources and raw materials, and the formulation of standards for certain special local products. Third, the system will be reformed specifically with respect to problems such as lack of emphasis, cumbersome procedure, inability to link to the national economic plan, and lack of supervision. The focus of the planning work is shifted from preparation of annual plans to mid -and long- term planning. Drafting of standards will be concentrated on the needs in fundamental construction, technical reform, technology import, technology exploitation, and import and export. Furthermore, a system to report the progress of implementation will be established so that measures can be taken in time to ensure the completion of the Plan. The fourth item is to reform the publication of standards. The publishing cycle will be reduced, the distribution network enlarged, and direct supply conduits developed. In addition, a series of reform must also take place in the drafting, review, and distribution of standards, as well as in the areas of organization and budget.

This is the year to throughly implement the resolutions of the 3d Plenary Session of the 12th CPC Central Committee. It is also a year to reform our urban economic system. As we work hard to reform standardization, we must also make progress in the following areas.

First, we must continue to adopt international and advanced foreign standards to promote technical advances. In the past 2 years, the guidelines, planning and managing methods in this area have been defined. The urgent matter is to actually adopt these standards when we draft our own standards and to actually implement them in production. Therefore, a review in these two aspects must be done in order to urge its implementation. Adopting international and advanced foreign standards is closely linked to technical reform in industries. Every department in each location must include the requirements for implementing these standards into its technical reform plan and support it with manpower, materials and expenses.

Second, standards must be classified into different levels so that a product is priced by its quality. Currently, most of our product standards are not categorized to meet this need. Moreover, it hinders the adoption of new technologies. The classification of product standards is relatively complicated, involving the economic welfare of many parties. We must actively pursue key products, starting from the easy ones and then gradually extending to more difficult ones as we gather more experience.

The third item is to establish the organization and build up teams to monitor and control product quality in order to raise our technical standard. To this end, we must first have a better understanding on product quality control. As we open our society to the world, quality control becomes more important as merchandise is manufactured. It must be strengthened to protect the interest of the country and the consumers. Next, we must resolve the responsibility of quality control so that no effort is duplicated. Then, we must beef up our testing methods, strengthen our teams and improve the quality. In this regard, each locality must work hard to resolve this problem.

The fourth item is to standardize imported technologies and equipment. As China opens its door wider to the outside world, more and more technologies and equipment are bought in, which is extremely beneficial to technical development and economic growth in China. In the past, many outfits did not care about standardization, leading to a confusion of product series, numerous models of equipment, and poor quality. The nation suffered unnecessary losses. Therefore, it is urgent to enhance this work. The standardization department in each department must seriously review imported technology and equipment in terms of standardization and quality.

The fifth item is to provide information on standardization. Standardization news will be provided by the relevant departments to the general public, not only to raise the technical level and capability of the personnel but also to provide advanced standards for local departments urgently in need of products standards. In the past, effort was made in this area with some success. All standardization societies should organize such activities to improve the quality of the industries in China.

The sixth item is to build up the standardization team and to raise the quality of its members. We should respect knowledge and authorities. The technical staff must be properly assigned so that their intelligence can be fully utilized. This is very important in speeding up standardization in China. In various forms, we should strengthen the training of the present personnel. In addition, we should offer professional courses in higher learning institutions to train new people.

The seventh item is to pass standardization laws. In recent years, many regulations have been issued in China to facilitate standardization. There is still a need to strengthen and perfect these laws so that standardization can be carried out according to the law.

The current national economy and the reform picture look very good. Let us contribute to the reform and new prospect of standardization and to the advances of technology under the guidance of the 3d Plenary Session of the 12th CPC Central Committee.

NATIONAL DEVELOPMENTS

DEVELOPMENT PLANS FOR SCIENCE, TECHNOLOGY IN LIAONING

Beijing KEZHANLUE KEJI GUANLI [STRATEGY AND MANAGEMENT OF SCIENCE AND TECHNOLOGY] in Chinese May 83 pp 268-275

[Article by Jiang Zhizheng [1203 5268 2973]: "A Preliminary Look at Development Strategies for Liaoning Science and Technology"]

[Text] The grand goal was proposed at the 12th Party Congress that by the year 2000 the annual gross output value of agriculture and industry will be quadrupled. For the whole country to quadruple production output, Liaoning must make a new contribution, the key to which is dependence upon advancements in science and technology. This article proceeds from the actual situation in Liaoning to make a preliminary exploration of problems in development strategies for Liaoning science and technology.

The central problem for development strategies for science and technology is how, when faced with economic construction, to more quickly promote and make an even greater contribution to the economy. Proceeding from this basic viewpoint I have made a few superficial points about problems for the goals, focus, future, and measures of developmental strategies for Liaoning's science and technology.

1. Make as an important strategic goal for the development of science and technology the energetic improvement of the proportion of the advance of science and technology in the growth rate of the national economy.

The Central Committee has clearly pointed out that in quadrupling the national output value, one-half of that will depend upon advancements in science and technology. For Liaoning, that should mean even a little more dependence on scientific and technological advances.

Make a couple of calculations. Based on forecasts by the Liaoning Provincial CPC Committee, if the annual gross output value for agriculture and industry in Liaoning could go from the 53.3 billion yuan of 1980 to 220 billion in 2000, that would be quadruple and would be in step with the rest of the country. But if we are to reach this goal of economic development, the level of natural resources necessary to create an output value of 100 million yuan based on the fixed assets needed at present to create 1 yuan of output value is not realizable. In 1980 the proportion of fixed assets in Liaoning to

industrial production value was one to one, that is, the gross value of 1 yuan of fixed assets created 1 yuan of output value. Calculating on this level, to realize an industrial output value of 1.8 trillion yuan in the year 2000 would require an increase in gross value of the 1981 fixed assets of 450 billion yuan to a fixed asset gross value of 1.8 trillion yuan, which is not possible. The 100 million yuan output value in Liaoning in 1980 consumed in energy 96,000 tons of standard coal. If we figure on this level, to realize a quadrupling of agricultural and industrial output value by 2000 the entire province would need 205 million tons of standard coal, and there is no way that could be done. With this great a deficiency in funds and energy, how can we quadruple anything?

Can we just rely on "capital?" No. After more than 30 years of construction, although Liaoning has a relatively rich material base, this "family property" is already behind the times. Based on the resources of the Liaoning Provincial Bureau of Statistics, 40 percent of fixed assets for current heavy industry in the whole province are obsolete. In enterprises, the majority are old enterprises from the 1950's, 1960's, and even the 1930's and 1940's. Only about one-tenth of industrial technology and equipment is from the 1970's, while 60 percent is from the 1950's and 1960's, and 30 percent is from the 1930's and 1940's. Obviously, it is not possible to base a quadrupling on this kind of "capital."

Could we base it on resources? No. Natural resources in Liaoning are comparatively abundant. The natural resources of iron, magnesite, and boron ores and tussah, apples, ginseng, and prawns are abundant. But some resources, like conventional energy, water resources, and agricultural resources are not so abundant. Coal mine and geologic reserves that have so far been discovered throughout the province make up only 0.89 percent of the total national coal reserves, while annual consumption in Liaoning is about 10 percent that of the whole country. Based on forecasts, by the end of the 1990's annual energy consumption in Liaoning will reach about 100 million tons of standard coal. Other conventional energy sources will be similar. The oil and natural gas reserves discovered to date in Liaoning can only be mined for 20 years. Fifty-six percent of hydroelectric resources throughout the province have already been exploited. Obviously, by the end of the century Liaoning will have become a province with serious deficiencies in energy. Per capita water resources and the water for each mu of arable land is only one-third of the national average. When the population on arable land is figured in with the multiple crop index it is less than the national per capita by 0.57 mu. Liaoning has 80 percent of the per capita forested land in China, but only one-eighteenth of the grazing land.

Can we depend upon an extensive expansion of production? Even less. Theoretically speaking, technical advance first depends upon labor productivity and second upon a lowering of the capital for a unit output value. For Liaoning this latter is most important. Comparing the net and gross values of Liaoning's fixed assets, it is one of the lowest among provinces, whereas the gross value of fixed assets is the highest. Were we to rashly expand and blindly increase our fixed assets, it would not only not be advantageous for doubling output value, but would become a factor in the hindrance of technical advancement.

So where do we go? Much material would indicate that economic development in Liaoning at present is largely at the same level as Japan on the eve of its "takeoff" in the mid-1950's. Beginning in 1955 Japan took about 20 years to develop by the mid-1970's into an economic power. According to the calculations of Japanese economists, in the Japanese economic growth of this time, factors dependent upon scientific and technical advances constituted approximately 50 to 60 percent. In China at present these are only from 10 to 30 percent. Although Liaoning is higher than average national levels it is lower than the levels of the provinces and municipalities of Shanghai, Jiangsu, Zhejiang, Guangdong, and Shandong. In the future, development of Liaoning's economy cannot chiefly again depend upon increased national investment and growth in jobs, but ought to place its main energy in improving the role of scientific and technical advancement in the growth rate of the national economy. This is not only a path that could be taken for Liaoning's economic promotion, but is also an important strategic goal for the development of science and technology in Liaoning.

2. Make a strong increase in research in production technology the strategic focus of scientific and technical development.

Generally speaking, standards for developments in science and technology lag behind international advanced standards. But there is also a great imbalance. Besides great differences between regions, this is also indicated in the actual standards of the three kinds of scientific research. In general, there is rather less difference between our basic research and international advanced standards, while in applications research it is greater, especially where the distance is greater in developmental research, but it is research into production technology that is the weakest. We could call this kind of unbalanced gap between the three categories of scientific research and advanced international standards a graduated gap. This is certainly not a condition unique to China, but for all countries having this graduated gap to a serious degree, even if there is a high standard in basic theory, economic development will be very slow. In analyzing the reasons for this, and from the view of external departments, it is chiefly because there is a lack of interest in science and technology among economic departments and production units, where there is no impetus to make use of new technology. From within science and technology departments neglect of research into production technology is a direct reason for the creation of the graduated gap. For a long time now, there has been a tendency within our scientific and technical circles to look down on research into production technology. People have worked on production and others have managed scientific research, but the important link of production technology has been largely ignored. This has caused the development of many advanced and sophisticated scientific and technical results, while the production technology problems, like a low heating efficiency rate for the common boiler, high fuel consumption by the average automobile engine, poor quality of everyday products, and unrefined processing of resources have been unsolved for a long time. Sometimes even if products or machines make it to testing rooms they never make it into production. We must say that this serious situation where there are obstacles to communications between scientific research and production, where there is this shelving of scientific results, is a great fault with the development strategy for science and technology. If this situation does not change, the

idea of science and technology gearing up for economic construction will be an empty phrase, and it will be very difficult to realize the goal proposed by the Central Committee that by the year 2000 production technology like that of international standards of the late 1970's and middle 1980's will be everywhere. Therefore, to fundamentally turn this tendency around has become the problem first affected in formulating development strategy for science and technology, as well as the key by which science and technology will serve economic invigoration. In order to ensure this strategic focus we need to first give it expression in scientific and technical planning, and need to determine the correct proportions for investment in the three kinds of research. Then, we need more guarantees in policy, and we need to guard against just paying attention to educational level and papers when considering the testing, promotion, and rewarding of scientific and technical personnel to be employed. We should take as chief criteria the ability to solve real problems and also make contributions to the national economy. Third, we must restructure unsuitable scientific research systems and gradually switch over from highly specialized independent scientific research organizations to enterprises and professions, forming technology development centers.

3. To make full use of developed science and technology both within China and outside it, as well as innovation, as an important strategic course for the development of science and technology.

Developments in science and technology cannot do without economic support. China's economic conditions are limited and cannot largely support the development of science and technology over a long period of time. The development of science and technology is also bound by educational conditions, where the development period for education is long, the results are slow, and scientific and technical talent cannot grow much in 10 years. Under these kinds of conditions, how to use the "resources" of limited manpower and funds where they can allow economic and social developments to more quickly attain even more material benefits from scientific and technical advances is an important premise for scientific and technical development. This means that development of China's science and technology should take a new path that as far as possible gets the most from the least. From the point of view of the future of strategy for the development of science and technology, in putting this new path into practice we should innovatively apply domestic and foreign developed science and technology. In the treasurehouse of modern science and technology, more and more achievements can be applied by us or serve as examples. If we ask what "keys" or "shortcuts" there are in getting the most from the least, the clever and creative application of developed technology, and making it work for us, is all a "shortcut" proven by a great number of facts both here and abroad. That in 4 years Liaoning Province could disseminate nearly everywhere the technology of groundfilm culture underglass, as well as obtain outstanding results, is just one example. Liaoning began importing this technology in 1979. At the beginning the test area was only 49 mu, with 16 kinds of crops under cover; in 1980 tests were extended to 20 kinds of crops, and the area was increased to 8,000 mu; in 1981 it was expanded to 70,000 mu; in 1982 it was abruptly increased to 420,000, with 40 different crops under cover. Widespread use of this technology allowed Liaoning Province to produce 60 million jin of peanuts, nearly 3 million jin of ginned cotton, and 100 million jin of vegetables. Importation of this

foreign technology is not locally important at present, for it is largely a question of how to apply technology already in China. According to the statistics of Sipingshi from 1979 through 1981, 76.5 percent of their activity was the digestion and innovation of developed domestic technology; accomplishments from cooperation with outside areas and application thereof amounted to 17.9 percent; that imported from abroad was only 2.5 percent; their own achievements plus applications were also only 3.1 percent. Obviously, the proportion of domestic mature technology that has been applied is quite large. Of course, for coastal cities and areas of abundant scientific and technical capacity there has been a greater proportion of imported foreign technology. Later, after passing through "second hand" use in these areas, technology that has been so digested is again transferred to other areas. Importation is not limited to a country and a region, it ought also to include importation between professions, as when military technology is transferred to civilian use, when industrial technology is transferred to agriculture, etc., all of which is a part of fully utilizing mature technology. In addition to all this, there is science and technology that seeps into completely different fields, giving impetus to each, as well as comprehensively using mature technology in a certain project, etc., which also is a part of full utilization of developed technology. Some people have said that America's launching of the Apollo rocket was an enormous example of comprehensive utilization of all kinds of related technologies existing in the world, which is not to depreciate the creativity of developing the Apollo rocket. Among the current items to be dealt with in China, the majority ought to be dealt with by comprehensive utilization of mature technology, where we do not take on a blind "starting from scratch."

4. Make the development of superior science and technology an important strategic measure in science and technology development.

A new viewpoint brought out by our scholars at the Tenth International Sociology Convention is that so called superior science and technology means the intimately connected group of sciences and technologies of superior resources, superior production, superior products, as well as the best economic and social results. In other words, if we are to fully utilize superior resources, and make them become superior industries and products that have the best economic and social results, then we must develop superior science and technology. In this way, superior resources-- superior science and technology-- superior industry-- and superior products, will become an intimately related organic whole, the key to which will be superior science and technology.

Among superior resources in Liaoning, and aside from mining reserves, which are about 22 percent of the nation's reserves, there is a preponderance of nonmetallic ore: diamond reserves are over half those of the whole country, and reserves of magnesite, boron, talc, bentonite, and jade rank at the nation's top. The magnesite reserves are one-fifth those of the world, which mined at the current mining capacity will last for more than 600 years, and the quality is excellent. Annual production of tussah cocoon is from 70 to 80 percent that of the whole country, and we are second in apple production, first in export. The valuable resources of ginseng, pilose antler, prawns, and sea cucumbers are famous throughout the world. How we can develop a

superior science and technology to fully utilize these resources is an important question that must be considered when formulating strategic measures for the development of science and technology in Liaoning.

The majority of the superior resources mentioned above have not yet been fully utilized. As for example magnesite, which although under development for quite awhile and which has established the chief base for China's magnesium materials, has not yet formed an industrial system, there are few products, and the quality is poor. With many products, second-class products are produced from first-class mineral resources and sold at third-class prices. Utilization of non-metallic resources like boron and bentonite is even worse. If we can develop a superior science and technology built around the rich non-metallic resources in Liaoning, and establish a group of distinctive technologies in the aspects of prospecting, excavation, material selection, refining, comprehensive utilization, as well as related processing, energy, and mechanization, then we can in consequence develop a superior industry and superior products, and form a non-metallic industrial system. It may be seen beforehand that this will become for Liaoning a new economic mainstay in addition to the four large current economic mainstays of steel, machinery, petroleum processing, and the building industry. Because of these conditions of richly endowed resources, their future for development and their important role for Liaoning and the national economy might surpass that of the current big four mainstays. Tussah is also a resource richly endowed in Liaoning, famous throughout the world. While there is a certain base for Liaoning's tussah silk industry, and the individual rate of earning foreign exchange is foremost among products within the province, still, because interrelated superior science and technology has not developed there are many technical problems with silkworm cultivation, silk reeling, weaving, and final processing. The technologies in the related aspects of silkworm field protection and development, tussah breeding, weaving and dyeing, dye boosters, and methods of final handling have not linked together, and even less have they not formed a system, which has created the current situation of low grade, inexpensive tussah silk products. If we avail ourselves of various measures and strive to develop relevant superior science and technology, and establish integrated scientific research and production systems from tussah breeding to silk production, comprehensive utilization, and chemical industry, it will all play an even greater role in the quadrupling of Liaoning's output. As with magnesite and tussah silkworms, if we fully utilize Liaoning's superior resources through development of superior science and technology, establish distinctive scientific research and production systems, then this will serve a decisive function in the invigoration of Liaoning's economy.

What is very interesting is that the majority of Liaoning's superior resources are distributed around the coastal region of Dalian, Dandong, Yingkou, and Mianzhou. The non-metallic resources of magnesite, boron, bentonite, and jade and the locally produced resources of tussah, ginseng, and apples, the abundant natural resources of the coastal areas and shores are all largely concentrated in this area, which can truly be called Liaoning's "Golden Shore." To develop superior science and technology around these abundant resources and establish superior scientific research and production systems, and establish unified considerations and planning for the economic zone that is this coastal area will certainly quicken the development of Liaoning's

superior science and technology. At present this area includes four cities, 14 counties (regions), 25.6 percent of the area of the province, 32 percent of the population, and 37.8 percent of gross industrial output. If this area can establish an economic zone with overall planning and development, that gives full play to the function of science and technology, and that energetically develops superior industry and superior products, its role will be even much greater than now.

12586

CSO: 4008/344

NATIONAL DEVELOPMENTS

WORKERS USE COMPUTERS IN SHIPBUILDING INDUSTRY

OW031127 Beijing XINHUA in English 1036 GMT 3 May 85

[Text] Beijing, 3 May (XINHUA)--Bao Weidong and his mates never imagined they would receive a national citation from the Communist Youth League (CYL) in Beijing today, when they first joined Shanghai's Hudong Shipyard two and a half years ago.

He and 17 other college graduates in shipbuilding had designed some 60 computer programs for designing, and were among the first college graduates of the 1980's to win the title of "shock worker" at a national conference ending here today.

They hit upon the idea of applying computer technology to ship designing when they saw the designers spend a tremendous amount of time on trial trip calculations. The proposal won instant approval from the leadership.

Hou Fangyan, a member of the group and a graduate of Shanghai's Jiaotong University, set the pace by developing 10 programs for calculating hull vibration frequency and structure stability.

These and other programs developed later were successfully applied to a trial of a 36,000-DWT bulk carrier after the young people had won the trust of the designers by comparing the computer and manual methods of calculation.

Results of the computer calculations were shown to representatives of Lloyd's register of shipping and the buyer when they came to Shanghai to pick up the carrier.

They promptly signed the papers for taking over the ship which later won a state gold medal for its excellent quality.

Computer technology has since been applied to such calculations on every trial run.

Bao Weidong, 25, also a graduate of the Shanghai Jiaotong University, serves as president of the Youth Shipbuilding Technology Association as well as Deputy Secretary of the CYL committee in the shipyard.

Always working on a tight schedule, he often has to attend meetings during the day and design programs at night.

He has applied to ship designing a program which ensures a more rational distribution of stress without adding stronger materials.

He told the conference that the service boat "Sydney," designed with the help of his group's computer programs, remained stable in a force 12 typhoon.

A computer program the group had developed for price quoting, in cooperation with other specialists, could provide buyers with 25 choices of ship designs, he said.

CSO: 4010/1004

NATIONAL DEVELOPMENTS

EDITORIAL URGES INCREASED USE OF COMPUTERS

OW100906 Beijing XINHUA in English 0815 GMT 10 May 85

[Text] Beijing, 10 May (XINHUA)--The number of Chinese civil projects using computers has soared to 10,000 from 100 five years ago, the "Economic Daily" reports today.

An editorial in the newspaper stresses the need to speed up use of computers to meet the challenge of modernization.

Computers will begin to be applied this year to control work processes, manage enterprises, store goods, handle bank work, dispatch railways, upgrade machine-building and monitor power grids.

Computers will also be used to design clothing, furniture and models for plastics, the paper says.

Successful computer systems will be used nationwide. These include monitoring of 200,000-kW thermal power generating units, automated storage and transport of petroleum products, the management of posts and telecommunications and monitoring harmful gases in mine shafts.

Marked progress has been made in software production and technical services since 1980, the paper says.

The China Software Technical Company now has branches in most parts of the country.

The China Computer Technical Service Company operates 14 training centers across the country. The number of its branches has risen from last year's seven to 33.

In addition, a national company providing computer systems engineering services and another undertaking construction of computer houses have been set up.

CSO: 4010/1004

NATIONAL DEVELOPMENTS

CHINESE NEWSPAPERS MAY USE DOMESTICALLY MADE TYPESET COMPUTERS

HK230547 Beijing CHINA DAILY in English 23 May 85 p 5

[Article by Li Xing]

[Text] Computers and laser technology at last are at the doors of Chinese newspapers and printing houses.

A new computer system that edits Chinese characters and typesets them by laser is hailed as a major breakthrough in an industry that was tied to tedious typesetting by hand because of the complicated Chinese written language.

The system was invented by scientists and engineers of Beijing University. Co-operating with them were Weifang Computer Plant in Shandong, Hangzhou Communication Instrument Plant in Zhejiang, and Wuxi Computer Plant in Jiangsu.

It took scientists and engineers nearly 10 years to design, manufacture and test the system. It recently was appraised and approved by the State Economic Commission.

Appraisers agreed that the new system will in time revolutionize the Chinese-character printing industry in much the same way as the invention of wood-block printing did in the 11th century. It now takes a highly trained typesetter three hours to collate the type by hand--usually about 11,000 characters--for one page of PEOPLE'S DAILY.

The invention of a computer system was placed as a major research project under the Ministry of Electronics Industry in the mid-1970's.

But two major obstacles stood in the way.

One was how many Chinese characters can be stored in the system and in what fashion.

Letters or characters are stored and processed in the computer by what technicians call "binary digits" or "bits." A bit is a unit of information derived by a binary (two-digit) code equivalent to the result of a choice between two alternatives (such as yes or no).

A Chinese character of newsprint size requires roughly 10,000 bits.

Printing houses and newspapers in China with 6 type faces for stories and headlines generally use an average of 7,000 Chinese characters. Each type-face consists of 16 sizes.

This means that the number of Chinese characters required to print a newspaper exceeds one million. Thousands of other rare characters used for specialized fields, must also be available. So the computer system must store around 20 billion bits.

For Romanized letters, scientists abroad have developed a method for compressing the capacity of font information, but the compression ratio is low. Storing 1 million characters requires a large disk, and using disks with large storage capacities usually decreases the speed of character generation in the typesetting system.

Several years ago, scientists tried to create a method to scale down Chinese characters, but the method had a serious drawback: characters often were deformed in print. Many in printing circles doubted if a data compression method could be invented that could also guarantee the quality of typesetting.

But Professor Wang Xuan and his colleagues at Beijing University took up the challenge and claim to have designed a way that uses a minimum of information bits to describe and store Chinese font, or a complete set of faces and sizes of type. Their method reduced the information from 20 billion bits to 50 million bits in computer memory. It also allows the system to typeset 1 million Chinese characters of different sizes and more than 1,300 symbols including the Roman alphabet, Arabic numerals, mathematical symbols and punctuation marks at an average rate of 180 characters per second. The new compression technique also enables the use of microcomputers to construct the system.

The other major obstacle in the mid-70's was the design of a phototypesetting machine. The most popular typesetting method used then was CRT's (cathode ray tubes).

Rather than copying such input terminals, engineers transformed a newspaper radio facsimile made by the Hangzhou Communication Instrument Factory into a typesetter by equipping it with laser devices. The resolution of the typesetter is 29.2 lines per millimeter. By July 1976, they had designed the system software and application software for the system.

When these two major obstacles were cleared, scientists and engineers turned to several factories to produce Chinese character visual display terminals.

Meanwhile, computer scientists designed programmes for operators to typeset and layout newspapers, magazines and books.

Joint efforts produced prototype systems for editing and typesetting in 1981, but domestic components were not reliable enough for practical use.

Engineers turned to imported integrated circuits while factories worked on improving their products.

Last March, XINHUA NEWS AGENCY agreed to try out the system at its printing house. In the next six months, scientists and engineers improved and corrected dozens of minor technical problems to make the software more efficient.

Early this year, XINHUA began turning out its Chinese-language news releases and journal using the new system. It has now replaced the agency's movable metal typesetter.

"Three months' trial shows that this China-designed and China-made system is able meet the demands of daily newspapers; and its software can be adapted to ordinary books and newspapers," the inventors said in a report.

A page of ordinary news print can be turned out at the rate of 60 characters per second.

Plans are made to replace the mini-computer system with microcomputer system and add high-resolution visual display terminals for newspaper layout design. Scientists also are working on software packages to allow composition of mathematical formula and chemical structures.

Several newspapers, including ECONOMIC DAILY, WORKERS' DAILY, ZHEJIANG DAILY and WEIFANG DAILY, are considering adopting the system next year on a trial basis. "The whole system will be as reliable as foreign imports," a senior engineer predicted.

CSO: 4010/1004

NATIONAL DEVELOPMENTS

NEW CHINESE CHARACTER MICROCOMPUTER NEARS PRODUCTION

Guangzhou GUANGDONG KEJI BAO in Chinese 4 May 84 p 3

[Article: "Final Design Evaluation for the GF-20/11A Chinese Character Microcomputer System"]

[Text] Based upon the prototype of the GF-20/11A Chinese character microcomputer system, the Computer Technology Institute of the Chinese Academy of Sciences, together with the Guangzhou Communications Equipment Plant of the Ministry of Posts and Telecommunications, the Shaoguan Radio Plant, and the Guangdong Provincial Institute of Electronics Technology made further advances and improvements, then finalized the design and made four prototypes, which after use by units in Beijing and Guangzhou were found to give excellent results and were welcomed by users.

The GF-20/11A Chinese character microcomputer system is a model of the GF20 system functionally distributed Chinese character microcomputer system. It is a system composed of a host computer, floppy disk drives, keyboard, VDT, and printer. Connections between system parts are made with plugs and ribbon cable. Because this system uses slide-in modular construction, it is compact and has a small footprint; also, the majority of the system and components are made with imported general parts, so performance is reliable and the display is clear; in addition, each system is independent and separable, so installation and repair is easy. The chief features of this system are: 1. flexible Chinese character input, can adapt to any character coding scheme, and has as well both Chinese character coded input and Chinese character large keyboard input, with easy interchange; 2. communication control routines are according to the basic rules for telegraph and telephone as determined by the Ministry of Posts and Telecommunications, so the system can connect directly with telegraph or telephone networks for long distance transmission of data and documents; 3. abundant software, with five high level languages all having Chinese character capability, which are provided especially for Chinese character related data bases and Chinese character document management systems, suitable for units of organizations, schools, hospitals, factory and mining enterprises, etc. to manage financial affairs, wages, personnel and technical files, library materials, warehouses, production control, etc.; 4. it is supplied with Chinese character graphics, English and numeric display, Chinese character printer, and a Chinese character screen editing program, suitable for office document editing, tabulation, and plotting;

5. internal system memory can be expanded to 1 megabyte, and externally there can be hard disks to 30 megabytes, which can meet the requirements of data statistical work with large amounts of data.

This system was a program organized by the Chinese Academy of Sciences and the Guangdong Provincial Science and Technology Commission to solve problems. It has recently passed final design evaluation. The evaluation stated that the design of this system is in accordance with our national condition, that it is a state of the art integrated information management system, and it recommended rapid dissemination and use. It is currently in production at the Ministry of Posts and Telecommunications Guangzhou Communications Equipment Plant, the Shaoguan Radio Plant, and the Chinese Academy of Sciences Computer Institute Test Plant.

12586

CSO: 4008/1021

24 June 1985

NATIONAL DEVELOPMENTS

SMART TERMINAL HANDLES CHINESE CHARACTERS

Haikou HAINAN RIBAO in Chinese 5 May 84 p 4

[Article by Wu Huijin [0702 2585 0513] and Qu Zhihong [2575 1807 4767]:
"Chinese Character Computer Typewriter Has Begun Small Scale Production"]

[Text] The Huabei Terminal Equipment Company has begun small scale production of low-cost Chinese character on-line terminals (called "Chinese character computer typewriter" for short). This machine uses the Chinese character coding scheme by Wang Yongmin [3769 3057 3046].

This Chinese character terminal, model number for which is ZD (for the first letters of the pinyin "zong duan" [terminal]) 111000, has a price under 10,000 yuan and is furnished with a keyboard, display screen, and memory. By using the machine's 26 keys one can type more than 6,000 different Chinese characters, as well as display them on the CRT. Those characters that have already been typed may be revised and deleted, and after revision will be automatically joined together, leaving no trace of the revision. After finalization of the document it may be saved, it may be typed out on paper (with separately available printer), or it may be transmitted to another place (with separately available communications equipment). Anyone who can write Chinese characters can operate it after a short period of instruction. This kind of machine is suitable for use by offices and editing departments. By linking up several, or even tens of these terminals and their host computers a document processing and transmission network can be formed. It is said that 50 units will be produced this year, all of which have been ordered beforehand.

The Huabei Terminal Equipment Company was formed from joining three units in 1981, and is a computer specialist company under the Ministry of Electronics Industries.

12586

CSO: 4008/1021

NATIONAL DEVELOPMENTS

SOFTWARE COMPANY OPENS BRANCH IN CHENGDU

Chengdu SICHUAN RIBAO in Chinese 5 May 84 p 1

[Article by Gu Longyuan [0657 7127 1254]: "The Chengdu Branch of the Chinese Software Technology Company Opens"]

[Text] A fresh new force in China's southwest region computer industry-- the China Software Technology Company, Chengdu Branch, officially opened on the eve of "1 May." This indicates that microcomputer popularization and utilization in our province had entered a new stage.

This company was formed jointly by the Chengdu Municipal Electronics Research Institute, the Chengdu Academy of Electronic Communications and Engineering, Sichuan University, and the Chengdu College of Science and Technology as a comprehensive joint organization to engage in computer software technology research, development, production, maintenance, management, and training. The company follows the director responsibility system under a board of directors, with Yang Hanbin [2799 3352 1755] as chairman of the board, Liu Jinde [0491 6930 1795] as vice chair, Wang Mingfa [3076 2494 4099] as director, and Li Zhiyuan [2621 2535 3220] as chief engineer.

This year the company will develop software for computer-aided enterprise management and for production process control, development and popularization software tools, will introduce and transfer advanced domestic and foreign system software and applications software, and will begin offering software technology personnel training and technical information, all of which will make new progress in the popularization and application of microcomputers.

At the inaugural conference, Lu Xiangyi [7120 4382 0001], head of the Office for Software Applications of the Computer Industry Management Bureau under the Ministry of Electronics Industries, representing the Ministry of Electronics Industries, read out the documents of establishment, and Hong Minguang [3163 3046 0342], Director of the Chinese Software Technology Company, together with those in charge of relevant provincial and municipal departments and institutions of higher education in the Chengdu area all offered their congratulations.

Institutions of higher education and graduate schools in places like Beijing and Shanghai also telegraphed their regards.

12586
CSO: 4008/1021

NATIONAL DEVELOPMENTS

PERIPHERALS COMPANY PRODUCES CHINESE CHARACTER PRINTER

Wuhan HUBEI RIBAO in Chinese 5 May 84 p 1

[Article by Wang Xin [3769 2450]: "Xiangfan Successfully Produces Microprocessor Controlled Dot Matrix Chinese Character Printer"]

[Text] The Xiangfan Municipal Computer Peripheral Factory has successfully produced a microprocessor controlled pin-type [dot matrix] Chinese character printer, thus providing an advanced peripheral for China's popularization and application of computers. This accomplishment was appraised on 27 April.

The Xiangfan Municipal Computer Peripheral Factory imported a microcomputer system from abroad. Over 3 years time, engineering technicians used this system to produce a pin console printer, a pin wide carriage Chinese character printer, a thermal console printer, and a Chinese character invoice machine, four types of printers to eight different specifications.

Application fields have constantly expanded along with the explosive development of China's computer operations, and people urgently need a small, multi-function Chinese character printer with computer interface. The Xiangfan Municipal Computer Peripheral Factory, with the support of relevant departments among the central authorities and some college and vocational schools and scientific research units in Sichuan, Hunan, and Hubei, developed in March of last year [1983] a microprocessor controlled pin-type Chinese character printer prototype, which produced good results when tested with a microcomputer.

From 25-27 April, the Hubei Provincial Machine-Building Industry Department was given responsibility by the Bureau of Devices and Instrumentation of the Ministry of Machine-Building Industry to sponsor and convene a pin-type Chinese character assessment conference. The more than 50 engineers and technical personnel who came from all over the country carried out an earnest examination and inspection of the pin-type Chinese character printer, as well as listened to the opinions of those who had tested the machine, and unanimously agreed that the design of the microprocessor controlled pin-type Chinese character printer was reasonable, that its performance was excellent, its functions relatively complete, and that it was of an advanced domestic standard. This pin-type Chinese printer weighs 45 kilograms and can print large size characters and graphics. It can print 35 Chinese characters per

second and can print 105 [non-Chinese] characters per second. It can print bidirectionally, can automatically determine the shortest line-feed distance, as well as jump over spaces at high speed, the cover opens when paper is exhausted, and the machines stops and sounds an alarm when jammed.

12586

CSO: 4008/1021

NATIONAL DEVELOPMENTS

NANJING PLANT MANUFACTURES MICROCOMPUTERS

Nanjing XINHUA RIBAO in Chinese 18 Apr 84 p 1

[Article by Zhu Weiwei [2612 5898 5898]: "Take In-- Digest-- Bring Forth New Ideas"]

[Text] In developing microcomputers, the Nanjing Wire Communications Equipment Plant stuck to the path of "Take in-- digest-- bring forth new ideas," with a great improvement in production scale and capability. Last year they provided 500 microcomputers with peripherals for economic departments and scientific research units both in and outside the province, and this year they expect to sell 5,000. This plant is currently an important base for China's microcomputer development.

This plant is a printer and microcomputer specialist plant that is a focus of national investment, with conditions favorable to aspects like channels for importing foreign advanced technology. In the past, they suffered when importing technology because they did not understand foreign pricing and imported some things at a very high cost that were neither particularly advanced nor useful. In recent years they have continued to learn from past experience and investigate conditions thoroughly before importing anything. Later, they imported based on the requirements of microcomputer development, with a goal and selectively. In this way they spent less money, but with good results. When it came to preparations for the establishment of a PC board production line, all the foreign companies were actively willing to sell entire production line packages, but this plant decided after evaluation to put together certain foreign advanced equipment based on existing equipment in the plant. They thoroughly understood international market pricing, talked with foreign businesses on many aspects, compared quality and pricing of products from all foreign companies, and after discriminating analysis selected the best, importing in all some equipment from eight countries and combined it all into a rather advanced PC board production line. When comparing this production line to the production lines that any foreign company sold, there is even greater automation, some equipment is more advanced, set up time was shorter, and the cost was about one-half. Over the last 6 years this plant has used this both positive and yet cautious attitude to import 300 sets of instruments and two production lines, which has allowed a fundamental restructuring of the equipment in the plant, and which has greatly increased production capacity.

After advanced equipment is imported in great quantity it must be digested, for otherwise there will be no way to resolve a series of usage and maintenance problems. In order to do this work well, this plant has organized the computer related technicians, established a special research organization, and has also set up a cooperative relationship with more than 10 institutions of higher education and scientific research units. For example, after bringing in a sample of the "Apple I" microcomputer they thoroughly understood the capabilities of this microcomputer after systematic testing and analysis, and even improved some of the deficiencies in the original machine. Then they established a flow of technology, and formed batch production capabilities. This kind of microcomputer has more than 1,000 software programs abroad, so technicians at this factory digested this software, selecting more than 50 suitable for China, which they then modified, spreading them throughout the country together with the machines.

On the basis of this importing and digesting, this plant has broadly selected from the best and boldly brought forth new ideas. The dot matrix printer is an important peripheral for the microcomputer, and the print head of the dot matrix printer is a key component of the printer. We wanted to import a print head production line but the asking price of foreign businesses was very high. Lu Xiaolong [7627 1420 7893], an engineer at this plant, headed a group of technicians, who on the basis of digesting and studying the technical principles of several foreign print heads made breakthroughs in the four major technical obstacles to develop a new model print head, making this product at an internationally advanced standard. For the last 6 years this plant has developed and manufactured altogether 10 different microcomputer products with Chinese characteristics, such as the "Zijin I" microcomputer, a long distance communications terminal, etc., as well as 18 different peripherals, such as a 24-pin Chinese character printer, a microcomputer Chinese character processing system, etc. Last year it sold 500 microcomputers to the state, with a net income of 15 million yuan.

The work of importing, digesting, and bringing forth new ideas requires that technical capacity follow closely along. For this reason, this plant has strengthened its training and renewal of knowledge. The plant has specifically set up a training center for rotating training of leading cadres, technical personnel, and workers by administrative levels and by specialty. So far, 50 percent of technical personnel have participated in the specialized training, and 86 percent of cadres not engaged in production have studied basic computer knowledge. For the past few years they have also selected 112 people for training abroad, and have also trained 120 college graduates through running a staff and worker college, which has replenished the first line of research and production. Now, this plant has formed a microcomputer talent brigade complete with design, research, and production, which can already basically meet the demands of developing microcomputers.

12586
CSO: 4008/1018

NATIONAL DEVELOPMENTS

SPECIFIC COMPUTER POPULARIZATION APPLICATIONS LISTED

Shenyang SHICHANG ZHOUBAO in Chinese 15 May 84 p 1

[Article by Wei Runsheng [7614 3387 3932]: "The First Group of 20 Items Concerning Popularization and Application of Computers in Liaoning"]

[Text] Recently, the computer leading small group of the provincial government determined that the items for computer applications in this province would be in three groups, "a group for popularization, a group for development, and a group for planning," among which there are 20 items in the first group for popularization.

In recent years the work in our province for popularization and application of computers has already begun to bear fruit in many departments and professions. The 20 items for popularization and application as recommended by the provincial government computer leading small group are items that have been proven rather successful through production application and actual practice. The 20 items for popularization and application are: a computer controlled soaking pit, model RXB-I thermal efficiency meter, automatic (JI SHI [1015 3044]) plasticity device, a watch automatic detection device, a temperature controlled device for chemical fiber stretching, a microprocessor monitoring system for looms, a microprocessor controlled three tiered milling machine, a microprocessor controlled large platform cable cutting machine, Angang enterprise management, enterprise supplemental management system, a real time monitoring system for electrical network operations, a computer controlled automatic wrapping machine, SJ-IA long distance telephone automatic billing and sorting, computer aided preferred design, enterprise management and data handling, completely automatic magnitude of traffic flow analysis and recording instruments, computers for medical diagnosis, a surface automatic testing system application for atmospheric pollution, microprocessor created weather forecasting, and barrage type measurement device for amount of sewage flow.

Among these 20 items in this province's first group for popularization and application, 75 percent are for popularization applications for strengthening current enterprise technical restructuring and management aspects. Twenty-five percent are popularization applications for departments concerned with people's everyday lives. These applications chiefly apply to departments and professions concerned with coal, refining, mechanization, posts and

communications, automatic instruments, weather forecasting, and traffic and transport, environmental protection, medicine and hygiene.

Broad application of these popularization items will promote improvements in the technical restructuring of current enterprises in this province, as well as economic results.

12586
CSO: 4008/1022

NATIONAL DEVELOPMENTS

MICROPROCESSOR CONTROLLED ENGINE TESTING DEVELOPED

Beijing BEIJING DIANZI BAO in Chinese 12 May 84 p 1

[Text] Operating dependability of internal combustion engines and their components is chiefly improved through endurance testing. Simulation of operations under real conditions while on the testing apparatus can reveal the malfunctions and design deficiencies possible during actual operations. Then, after revision we will have improved the working life of the internal combustion engine and its components. However, endurance testing requires that during a testing process as much as several thousand hours of loading be changed according to sequence, which requires constant checking of testing parameters, as well as monitoring of the testing process. These are all things that manual operations just cannot handle.

With the support of relevant units at the Wenzhou Refining Machinery Factory, a "microprocessor controlled system for machine oil pump endurance testing" was successfully developed that can make simulated endurance tests and performance tests on an oil pump, a chief component of internal combustion engines, and its operation. This has been very effective, and has recently passed its technical evaluation. The core component of this system is the domestically produced DJS-040 four-bit microprocessor, which can automatically change the load curve and change the speed of operation according to the user's specifications, as well as press a key to input the rotation speed for constant operation. The test parameters can be printed out at specified times or randomly, where the specified times are set by keyboard input. When at any moment test parameters exceed a fixed value, the system will note the scale of the malfunction and separately give an alarm and stop the vehicle, and at the same time print and record the various parameters at the time of the malfunction. The intelligence of the endurance testing reduces the degree of manual operations, and in addition running under varying loads strengthens the results of testing, shortens the testing time, and saves a great deal of energy. This has characteristics of structural simplicity, ease in maintenance, less investment, and quicker results.

12586
CSO: 4008/1022

NATIONAL DEVELOPMENTS

NEW SEISMOLOGY RESEARCH FUND ALLOCATION SYSTEM EXPLAINED

Tianjin KEXUEXUE YU KEXUE JISHU GUANLI [SCIENTIOLOGY AND MANAGEMENT OF SCIENCE AND TECHNOLOGY] in Chinese No 3, 12 Mar 85 pp 2-3

[Article by Chen Yong [7115 7581], director of the Geophysics Research Institute of the State Bureau of Seismology: "Fund System Will Promote China's Basic Scientific Development"; responsible editor: Wang Kejian [3769 0344 0313]]

[Text] Beginning with the opening up of technical markets and the reform of the fund allocation system, the Central Committee's relevant decisions on scientific and technological [S&T] system reform have enabled China to establish gradually a new S&T system. These decisions are having a far-reaching effect on the development of S&T work.

There are various levels of S&T work such as basic research, applied research and technological development. How to carry out various fund allocation systems based on the distinct characteristics of various levels or types of S&T activity is obviously a very important problem in S&T reform. In the present research organization management system, the state does not distinguish between levels or types, but it allocates funds uniformly from the higher-level administrative departments according to the unit and the number of people. Within research organizations, "those below also follow the example of those above." The disadvantages of this management system have caused scientific research units to "lack vigor but survive" and have "halted projects which should be continued and continued ones which should be stopped." Although the state has also formulated long-range and annual plans to develop science, it has no corresponding system to ensure their implementation. Subordinates report scientific research problems to the higher authorities whose approval is often disguised as directed planning. As to who synthesizes the state's general scientific research tasks and who sets the direction of S&T development, a specific responsible department cannot be found. Therefore, judged by national economic construction needs and the development of disciplines, the state can neither guide macroscopically or invigorate microcosmically. Judged by the whole country and under the conditions of the departmental and local system of ownership, too many isolated "grandmothers" with power and money and a lack of competition will certainly cause the decentralization of S&T forces, the repetition of low standards and poor competitive

ability in the international academic arena and will increase our disparity from advanced international standards. The major causes producing these disadvantages are not whether administrative department leaders are "enlightened" or "capable," but whether they are in the S&T and fund allocation systems themselves.

Premier Zhao Ziyang confirmed the experience of the Zhuzhou Electronics Institute in his May 1984 "Government Work Report" and clarified the direction of the gradual implementation of the technological contract system in technological development work. Changing the fund allocation pattern has invigorated development work. This has been an unprecedented and excellent thing, but its resultant conflict with the basic and applied research ranks cannot be underrated. It is common knowledge that basic and applied research are closely linked to overall national S&T standards and long-range national economic results. Thus, how basic and applied research work is reformed and how the stability of the basic and applied research S&R ranks is maintained have become very prominent problems. In order to explore ways to solve these problems and to move gradually from the payment of operating expenses to a fund system, four units--i.e., the State Bureau of Seismology's Geophysics Institute, the Engineering Mechanics Institute, Beijing University's Geology Department and the China S&T University's Earth Science Department--have combined their funds (along with the wages of the concerned personnel) for basic and applied seismology research, have pooled their resources and have raised a joint seismology science fund. These four units are administratively subordinate to the State Bureau of Seismology, the Ministry of Education and the Chinese Academy of Sciences, and the joint fund does not have any departmental significance. It is geared to the needs of the same field throughout China and subsidizes the best basic and applied research in seismology, geophysics related to earthquake prediction and seismic engineering.

The joint fund association has accomplished the following tasks in the past half-year:

1. It Has Raised Funds

The four units have combined their funds used for basic and applied seismological research along with the wages of 230 people in the research institutes and the supporting fund allocation (500,000 yuan) from the higher authorities to establish a 3.08-million-yuan fund.

2. It has Issued Fund Guides

Based on the long-range needs of national economic development, an analysis of present international seismological conditions and predictions of development trends, it has issued periodic fund guides. The fund guides are the priority areas and problem areas which must be supported by science funds and the fund allocation proportions for all disciplines. The fund guides delineate blueprints for the development prospects of the said disciplines for the years 1990 and 2000 and, through the lever of fund allocation, guide the "direction" of scientific research work and thus the

realization of these blueprints. The project of formulating and issuing fund guides are an especially important matter in carrying out the fund system and this project can collect the individual intelligence and wisdom of dispersed scientists, form a powerful force and rush it to the fields most needed by the country and to the forward positions of world academic circles.

3. Geared to Needs Throughout China and Based on the Free Application for Research Problems, It Has Carried out Appraisals by People in the Same Fields and Subsidized the Best

Funds have been geared to needs throughout China, applications from various regions and units and from scientists and technicians having various qualifications and records of service have been treated equally without discrimination, competition has been encouraged and cooperation has been promoted. The fund association has carried out appraisals of project applications by people in the same fields and subsidized the best. It has asked academic experts in the same fields to make specific suggestions on the academic value, application prospects and technological itineraries of application problems, the feasibility of experimental plans and the professional ability of academic leaders. The results of their appraisals are an important basis by which to determine whether application problems will receive support.

4. It Has Allocated Funds Based on Problems

After problem applications have been approved, except for a specific proportion of management expenses given to their units by the higher authorities, the people who are responsible for the problems have full power to use other funds according to fund regulations for covering scientific research expenses, purchasing instruments and equipment, paying wages and giving subsidies (including the cost of hiring temporary assistants such as college and graduate students during summer and winter vacations). Provided they conform to the fund association rules and regulations, they cannot be restricted by any department. We are now applying for a specific number of foreign exchange quotas from leading higher-level departments to be used for carrying out international academic exchanges (including going abroad on tours of investigation, participating in international conferences, holding international academic conferences in China and engaging in cooperative research with foreigners in similar fields); this method will enable research problem groups to be full of vigor and truly invigorate microcosmic S&T work. Having applications and fund allocations based on problems and not on units has essentially established a scientific research economic job responsibility system for basic and applied research tasks and put the responsibility on people (problem group leaders and members).

Finally, the joint science fund association has examined 10 research problems which conformed to fund guide directions. The results were that three problems were subsidized, two were discussed and obtained permission

to be merged into one and the other five were refused. This has evoked great repercussions among scientific researchers.

Problem groups which were subsidized regarded obtaining the subsidies as an academic honor and as a sign of the confidence of those in their fields. They are now assimilating the ideas proposed by experts in their fields through examination, intensely and conscientiously carrying out plans and carefully calculating and strictly budgeting the use of "their own" funds. These problem groups are full of joyous vitality.

Comrades who did not receive fund subsidies have been able to listen open-mindedly to the ideas of the examinations, renew their investigations and studies, further revise them and prepare to make new applications. Some comrades have also made preparations to change to other research problems or engage in development work. Prior to the announcement of the examinations, some people thought that after the examination results were issued, comrades who did not obtain permission for their projects might approach the fund association office to argue. But this did not in fact occur, which shows that a fair scientific examination is convincing to everyone.

Seeing that so many problems were not subsidized, comrades who are preparing to apply for funds have profoundly felt that appraisal by people in the same field is a very serious matter and that they cannot be careless to the slightest degree. They have been restudying and improving their application plans one after another and striving to improve them constantly. They are worried that if their applications are refused, they will be unable to obtain funds and their reputations will be damaged. Senior researchers such as research fellows and assistant research fellows in particular are subject to even greater pressures. Some comrades do not want to apply for problems alone, having expressed the desire to act as assistant to responsible people who hope to obtain permission for their problems, and they have gradually been concentrating around key personnel. On the other hand, graduate students who have just graduated are very dynamic and eager to have a try.

A half-year is still too short a time for an S&T reform experiment. But a half-year of practice has increased our confidence that the carrying out of a fund system will be favorable to maintaining the stability of S&T contingents which are engaged in basic and applied research, to improving the quality and increasing the vitality of scientific research units, to strengthening the sense of responsibility of scientific researchers and to encouraging them to develop a creative spirit. It will promote the development of China's basic scientific research.

12267
CSO: 4008/323

NATIONAL DEVELOPMENTS

EXPANSION OF VOCATIONAL HIGH SCHOOL EDUCATION ADVOCATED

Beijing RENMIN RIBAO in Chinese 28 Apr 85 p 5

[Article by Wen Ke [5113 0668] of the Hubei Planning Commission: "Vigorously Expand Vocational Education Which Benefits Both the Country and the People"]

[Text] The technical education standards of China's workers are seriously low. Technicians now constitute only 3.45 percent of the staff members and workers in publicly owned enterprises throughout China. Among industrial department staff members and workers, those with a junior high school education or lower constitute 78 percent, and 7.9 percent of these are illiterate or semiliterate; among technicians throughout China, those with a grade-1 to grade-3 technical level constitute 71 percent. This situation must not continue.

Education is the major way to create all types and levels of labor reserves, it plays a labor-saving role during a specific stage and its development directly affects the quantity, structure and quality of the labor reserves. We now have over 9.5 million junior high school graduates a year, but ordinary senior high schools only enroll a little over 2.6 million; less than 20 percent of these can go to college. Specialized high schools, technical schools and vocational high schools enroll over 1 million. Thus, there are still nearly 8 million junior and senior high school graduates who will miss out on the opportunity to go to higher-grade schools and will pour into the labor reserves. On the one hand, there are a large number of these labor reserve forces, which creates great employment pressure; on the other hand, their quality is poor and the need to transport them continuously to all trades is unfavorable to improving labor productivity and economic results. Problems in both areas are urgently awaiting the exploration of effective ways to solve them.

Ordinary senior high school education at present has become seriously onesided, with teaching plans, curricula and the contents of teaching materials basically serving those who go to higher-grade schools. Trained students do not have specialized technical abilities and have missed out on the opportunity to go to higher-grade schools, and since the country urgently needs labor, a considerable number go directly to work posts. Their not having definite specialized technical abilities and the essential employment ideology and preparation and their poor technical quality have a great effect on the improvement of labor productivity and economic results. For instance, the broadcloth looms in a recently built cotton textile mill (the Jingsha Cotton Textile Mill) with over 7,000 staff members and workers in Hubei Province's Shashi City constitute half of the number

of looms in Hubei Province and many machines are imported pieces of top-grade equipment. But since most new workers did not undergo vocational technical training prior to entering the mill and their technical quality was poor, 48 recently imported carding machines were damaged 52 times in 8 months; this stopped production and caused the mill to suffer losses for a long period of time. Sharply contrasting with this is another large-scale cotton-spinning enterprise (the Shashi Cotton Textile Mill) which also has over 7,000 staff members and workers and in which workshop equipment is far less advanced than in the previous example. But since new workers receive technical training before taking up their posts, annual profits have reached 15 million yuan.

China's present vocational technical education mainly includes specialized high schools, technical schools and vocational high schools. The annual enrollment in these 3 types of schools is only 1.7 million or 65 percent of that of ordinary senior high schools. How can they be quickly expanded in the future? The construction investment is large and the results slow in China's traditional specialized high schools and technical schools, and due to causes such as the administrative system, even though it has been repeatedly advocated, they still have been unable to expand very quickly and only enroll slightly over 800,000 a year. Overreliance on these two types of schools to strive for a large expansion of vocational technical education in fact will not do. Thus, the expansion of vocational high schools should be stressed. Judged by investment results, the investment needed to train a vocational high school student is one-quarter that of training a technical school student and one-tenth that of training a technical high school student. Since the training of students is closely linked to economic and social development needs and recently established specialities are quickly adaptable, it has strengthened planning, purposefulness and professionalism in training qualified personnel, achieved twice the results with half the effort and benefited the country and the people. For instance, based on industrial structure development trends, and since business unit labor reserve force needs have been investigated for the past 5 years, Hubei Province's Shashi City planning commission and labor personnel bureau have formulated special installation and enrollment plans for vocational high schools with the bureau of education, and the labor personnel bureau has included vocational high school graduates in its labor plans. During the construction of Shashi City's largest multi-storey department store building, 3 commodity management vocational classes were held in a planned way, over 100 students were enrolled and, after construction was completed, the graduates promptly took up work posts and solved urgent needs. The Shashi City employment rate has now reached 99.5 percent and the scope of employment has exceeded 70 percent. Rapid expansion of vocational high schools has naturally reduced the extent of crowding on the route of taking examinations for schools of higher grades and has alleviated the contradictions of senior high schools being divided into fast and slow classes.

12267

CSO: 4008/331

NATIONAL DEVELOPMENTS

IMPROVING INTERNATIONAL SCIENTIFIC RESEARCH COOPERATION SUGGESTED

Beijing LIAOWANG [OUTLOOK] in Chinese No 8, 25 Feb 85 p 45

[Article: "Chinese Academy of Sciences Education Department Committee Member Tang Xiaowei Suggests Improving International Cooperation on Scientific Experiments"]

[Text] Tang Xiaowei [0781 1321 1218], committee member of the Chinese Academy of Sciences Education Department and director of 14 research offices of the High-energy Physics Research Institute, thinks that scientific experiments should be coordinated throughout the world.

Tang Xiaowei took a Chinese research group to "The Electronics Synchrotron Center of the Federal Republic of Germany" in Hamburg in January 1978 to participate in a "Ma Ke Jie" [phonetic] group experiment led by United States scholar, Professor Ding Zhaozhong [0002 5128 0022]. This was the first large-scale scientific research cooperation between scientists from China and Western countries. The "Ma ke Jie" group is composed of 60 physicists and approximately 40 technicians from 5 countries; Chinese scientists have so far published 27 papers, of which the discovery of sanpenzhu [0005 0899 6087] has provided an experimental basis for strengthening the existing theory on the interaction of intermediary "gluon" and they have received favorable comments from Professor Ding Zhaozhong and foreigners in the same field. Tang Xiaowei also participated in international cooperation projects with the European Nuclear Research Center's "L3" group in 1982.

Tang Xiaowei said that international cooperation experiments are now the general practice in scientific circles throughout the world. Research on certain developing disciplines and scientific research projects which need large-scale equipment have been concentrated abroad in research centers or national laboratories, and many laboratories have been opened to the whole world and have become international arenas for cooperative research. Researchers on atomic reactors, energy conversion accelerators, synchronized radiation and plasma experiments in physics have all adopted this practice. Extensive international cooperation has also developed in fields such as biology, medicine, chemistry and astronomy.

Tang Xiaowei said that the scope of accelerator and high-energy experiments has been expanding, the number of researchers in each problem group has been increasing and there are four experiment groups performing experiments in cai po dui

zhuang ji [5475 3380 1417 2326 2894] alone; of these, the "L3" group located in China has 300 physicists from all countries. This shows that large-scale international cooperation is imperative in experimental research such as this.

Tang Xiaowei pointed out that international cooperation and competition in science and technology [S&T] is a challenge and an opportunity for us. Choosing accurate targets, organizing contingents, cooperating throughout the world and actively participating in this kind of cooperation and competition will be favorable to promoting the development of China's S&T. Certain Chinese colleges, universities and scientific research units including industrial departments and local scientific research units are qualified to undertake this effort. This is more effective and comprehensive than sending individual scholars abroad to engage in advanced studies or work. Participating in first-rate experiments in international laboratories can put us in the most advanced S&T position in the world, help us use the strong points of all countries, make up for our deficiencies, toughen up our ranks and train our qualified personnel. It will also be favorable to continuously importing and digesting advanced foreign technology, thus enabling it to take root and blossom in China.

Tang Xiaowei said that the practice abroad of opening up certain research centers to foreign countries provides large-scale equipment and general instruments to foreign experiment groups free of charge. Experiment groups can cooperate with the research center or other research groups, design experiment plans and make applications; after receiving approval, they can go to the research center and perform experiments for a time, the experiment results being equally shared with participating cooperative units. Research groups which perform experiments must generally prepare special experiment instruments and can also form cooperative groups with other research groups and jointly prepare experiments. Travel and living expenses must be raised on one's own, but financial aid can also be obtained through various channels. Research groups use the research center's equipment to perform experiments and obtain experiment data, but experiment preparation work and analysis of experiment data are generally carried out in their own countries; in this way, most of experiment researchers' work time is spent in their own countries.

12267

CSO: 4008/331

NATIONAL DEVELOPMENTS

BRIEFS

OPERATION FOR RESEARCH, PRODUCTION--In order to invigorate the electronics industry, the Nanjing Academy of Engineering and the China Nanjing Radio Company, based on the principle of joint development, shared name recognition, equal profits, and a reasonable distribution, formed after consultations a joint organization for scientific research and production centering on new products and the exploitation of intelligence. This joint operation formulated 5 points and 12 items concerning their contract. The provisions are: during the next 7 years, using the methods of transfer of achievements, commissioned development, and joint development they will research new products and new technologies in aspects of broadcast television, communications radar, photoelectric devices, integrated circuits, and computer applications; they will develop talent, train graduate students and majors in these areas, and hold specialized training classes; they will jointly establish evaluation centers and testing bases; they will develop technical consulting, exchange of technicians, scientific and technical intelligence and information, etc. This joint operation will be led by a seven person board of directors, and under the board of directors there will be two committees for new products and development of potential, respectively. The former first secretary of the Nanjing Municipal Party Commission, Wang Bingshi [3076 0393 4258], will be chairman of the board, and the head of Nanjing Academy of Engineering, Guan Zhizhong [4619 5268 0022] and the general manager of the China Nanjing Radio Company, Wang Rongbing [3769 2837 3521], will both be vice chairs. [Text] [Beijing BEIJING DIANZI BAO] in Chinese 12 May 84 p 1] 12586

COMPUTER LEASING BEGINS-- The China Bank of Industry and Commerce, Shanghai Municipality Branch, has recently decided to open a computer financing and leasing service to help enterprise units and public agencies utilize new computer technology, interest and processing charges for which will be given a certain preference. All enterprise units and public agencies that for reasons of insufficient funds cannot themselves purchase computers may, after approval by the responsible departments, apply to the credit department of this branch of the Bank of Industry and Commerce for processing, which after the credit department releases the funds for purchase, will lease the equipment to the unit. Recently, the credit department of the Municipal Bank of Industry and Commerce has signed letters of intent to lease computer equipment with departments in the municipal instrumentation and textile industries for a total of 128 units; they have also received lease applications from 28 enterprises, among them refining, chemicals, building materials, etc., to rent out more than 30 units of various computer equipment. [Text] [Article by Ding Jiuru [0002 0046 1172]] [Shanghai WEN HUI BAO in Chinese 10 May 84 p 1] 12586

24 June 1985

MARKETING OF MICROCOMPUTERS--The Hainan District Electronics Industry Co has recently reached an agreement with the Yanjin Computer Development Co to cooperate in the production and marketing of the CV series of microcomputers. They have also determined that a computer technology training class will be held in Haikou beginning next month in order to quickly develop creative conditions for the computer industry in our district. The Yanjin Computer Development Co was founded cooperatively by the Beijing Academy of Computing and the Liaoyuan Radio Factory No 3 of Jilin Province, and has a rich technical capability. Since the fourth quarter of last year [1983] the Hainan Electronics Industry Co has held talks with this company on several occasions, and have reached an agreement to cooperatively produce and market computers. The agreement provides for first opening small scale cooperation, importing key components from abroad, configuring domestically produced peripherals, and manufacturing the CV-1 computer, requiring sales of 50 units during the year; at the same time, the "Introduction to Computers Class" and the "Microcomputer User Training Class" held by technicians sent from that company will help relevant units in our district foster talent in using computers. [Text] [Haikou HAINAN RIBAO in Chinese 17 Apr 84 p 1] 12586

MICROCOMPUTER STATION ESTABLISHED--The first computer station in rural China--the Xiaotangshan Computer Station of suburban district Beijing has begun serving agriculture. This computer station is run by Xiaotangshan township of Changping County in Beijing Municipality, using a BCM-3 microcomputer. The mission of the computer station is to be responsible, for both the Xiaotangshan township and others, for calculations of the temperatures needed for growth by all sorts of plants, reasonable amounts to be sown, planting densities, fertilizer to be applied, amounts of water for irrigation, etc., and to analyze the trace elements in the soil; it will do accounting for production costs and budget profits for various rural industries; it will select the best composition for feed, as well as calculate the temperatures, humidity, and light needed by plants in greenhouses. According to a description by comrades involved, the BCM-3 microcomputer used at this computer station is the first microcomputer of relatively high quality used at present in rural China. [Text] [Haikou HAINAN RIBAO in Chinese 24 Apr 84 p 3] 12586

NINGXIA CHEMICAL PLANT--Yinchuan, 16 May (XINHUA)--Work began here today on a plant to produce 300,000 tons of synthetic ammonia and over half a million tons of urea annually. One of China's top-priority projects, the Ningxia Chemical Plant will import equipment from Japan, the Netherlands and Federal Germany. When completed in late 1987, it will greatly ease chemical fertilizer shortages in northwestern China--the Ningxia and Xinjiang Autonomous Regions and Gansu, Shaanxi and Qinghai Provinces. [Text] [Beijing XINHUA in English 1648 GMT 16 May 85 OW]

COMPUTER SOFTWARE DEVELOPMENT--Scores of computer experts from more than 30 units all over China gathered recently in Beijing where they jointly opened talks on the problem of application software for the domestically manufactured "Changcheng--0520" microcomputer. This indicates that preparatory work on China's application software is about to enter a period of joint development after one of "each to his own." Over the last 2 years the manufacture of microcomputer hardware in China has developed quickly, as the annual production rate of microcomputers (including single board computers of simple functions) already exceeds 10,000 units. But because development of microcomputer software has not kept up, this has kept computers from fully realizing their potential. One important reason creating this kind of situation is that there are still only a relatively few technical personnel engaged in computer software development. The few specialists and technicians involved are also scattered throughout different departments and units throughout the country, each on his own, without communication, each doing everything, which has caused much repetition and waste. In the face of this situation, with the lead of the Computer Industry Management Bureau and the Institute for Computer Extended Applications, both affiliated with the Ministry of Electronics Industries, these specialists were all invited together to jointly study the option of joint development of computer applications software. Organizing the limited specialist technical capability together to form a joint group for computer application software, manufacture, service, training, and marketing will promote the spread and expansion of computers. [Text] [Haikou HAINAN RIBAO in Chinese 24 Apr 84 p 1] 12586

TIANJIN HARBOR TELEVISION SYSTEM--Tianjin, 12 May (XINHUA)--China's first harbour-use closed circuit television system passed certificate test here Friday. Installed at the Operation Zone No 1 of the Tianjin New Harbor, the system, with its 7 lenses, can take photographs on an area of 480,000 square meters in all weather. During the night, it works with the help of moonlight or light from a 60-watt electric bulb. The system, which has been trial-used for half a year, was manufactured jointly by Institute No 2 of the Ministry of Astronautics [?] and the [Tianjin] Harbor Administration [Bureau]. [Text] [Beijing XINHUA in English 1258 GMT 12 May 85 OW]

CSO: 4010/1004

APPLIED SCIENCES

PRELIMINARY EXPERIMENTAL RESULTS OF CT-6B TOKAMAK HEATING FIELD VOLTAGE
FEEDBACK CONTROL

Beijing KEXUE TONGBAO [SCIENCE BULLETIN] in Chinese No 12, 1984 pp 728-731

[Article by Zheng Shaobai [6774 1421 4101], Shen Zhongqing [3088 0112 0615]]

[Text] In order to maintain the constant stability of a Tokamak plasma, it is necessary to control the displacement and electric current of the plasma. Generally, the control of displacement is accomplished by applying a vertical field with negative feedback. A similar approach is used in the CT-6B setup where preliminary results have been obtained^[1]. The control of plasma current is often accomplished using the method of multiple power sources which are connected sequentially. In recent years, the method of feedback control has been developed in ASDEX to control plasma current^[2]. But the two controls are carried out independently. In the CT-6B setup, we have experimented with the idea of applying negative feedback control to the voltage of the heating field to control the plasma current and displacement simultaneously. This article describes the basic principle of this control technique and presents some preliminary experimental results.

Control Principle

In a Tokamak setup, the value of the plasma current can be varied by changing the voltage of the heating field. Furthermore, under a given vertical field, variations in the current can induce horizontal displacement of the plasma column. Therefore, in principle, it is possible to affect the plasma current and its horizontal displacement simultaneously by controlling the voltage of the heating field.

Let U_H be the voltage of the equivalent single-turn heating field. It is composed of two parts: a feedback-independent part (U_{H0}) and a feedback-dependent part. Thus,

$$U_H = U_{H0} - k_1(I_p - I_{p0}) - k_2(I_p X - I_{p0} X_0), \quad (1)$$

where I_p , X are the electric current and horizontal displacement of the plasma. I_{p0} , X_0 are the equilibrium values to be maintained. The quantity $I_p X$ is chosen as the feedback source signal because the signal obtained from the cosine- and saddle-shaped detection coil is proportional to $I_p X$ ^[3]. k_1 , k_2 are the feedback coefficients.

We used the 0th order plasma equilibrium equation, and took into consideration the effects of screens in the vacuum chamber and the induction effects of iron-core transformers^[4]. By using the CT-6B parameters and the linear feedback equation given in equation (1), calculations have been carried out for the entire feedback system. The results show that:

(1) In order to maintain stability of the system under feedback control, the feedback coefficients k_1 , k_2 must satisfy certain relation. Figure 1 shows the calculated stable region of the CT-6B feedback control. In the experiment, the feedback coefficients must be chosen to fall in the stable region of Figure 1; otherwise, any disturbances in the plasma parameters will eventually result in the loss of control of the plasma current and displacement.

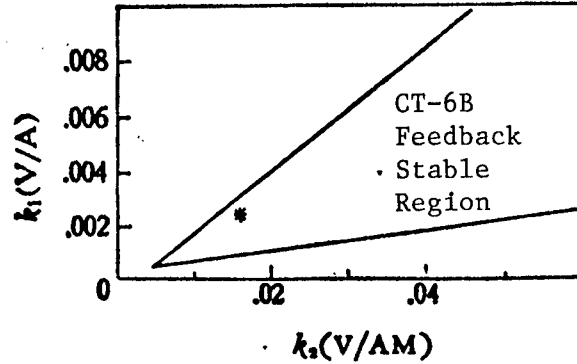

Figure 1. CT-6B Feedback Stable Region

(* denotes the feedback coefficients used in the experiment)

(2) Since the feedback process involves adjusting a voltage to control two plasma parameters, the final stable values of the plasma current and displacement are determined by the feedback equation

$$U_{HO} - k_1(I_p - I_{po}) - k_2(I_p X - I_{po} X_o) = R_p I_p, \quad (2)$$

and the equilibrium equation^[5]

$$B_1 = \frac{I_p}{CR} \left(\ln \frac{8R}{a_p} + \beta_1 + \frac{l_i}{2} - \frac{3}{2} \right) \quad (3)$$

where R , a_p , β_1 , l_i , R_p are respectively the large and small radii of the plasma ring, the angular β value, the internal inductance and resistance. B_1 is the externally applied vertical field. If there is a disturbance in the discharge parameters $\beta_1 + \frac{l_i}{2}$ and B_1 , denoted by $\Delta(\beta_1 + \frac{l_i}{2})$ and ΔB_1 , then the final stable values of I_p and X will change accordingly. When the disturbance is small, the equations can be linearized to give:

$$\frac{I_p - I_{po}}{I_{po}} = A_{11} \Delta(\beta_1 + \frac{l_i}{2}) + A_{12} \frac{\Delta B_1}{B_1}, \quad (4)$$

$$x - x_0 = A_{21} \Delta \left(\beta_I + \frac{1_i}{2} \right) + A_{22} \frac{\Delta B_1}{B_1}, \quad (5)$$

where the numerical values of A_{ij} depend on the feedback coefficients. The calculated results show that in the feedback stable region of Figure 1, the following conditions are satisfied over a fairly wide range:

$$\begin{aligned} |A_{11}| < 1, & \quad |A_{12}| < 2 \\ |A_{21}| < 10 \text{ cm}, & \quad |A_{22}| < 20 \text{ cm}. \end{aligned}$$

Therefore, this feedback can be used to control the plateau region of the Tokamak current. In this region, the values of B_1 and $\beta_I + \frac{1_i}{2}$ change very little (e.g., $\left| \frac{\Delta B_1}{B_1} \right| < 5\%$, $\left| \Delta \left(\beta_I + \frac{1_i}{2} \right) \right| < 0.1$). But when the parameters undergo violent changes, control will be difficult.

Experimental Procedure

The CT-6B experimental setup is a modification of the CT-6 setup [6]. The modified setup has no copper plate, and the vacuum chamber is made of welded 2-mm thick stainless steel plates. The large radius is 45 cm, the small radius is 15 cm, and the penetration time of the vertical field is 0.3 millisecond. The modified longitudinal field is powered by the main condenser with artificial line; the duration of the plateau region where the magnetic field varies less than 5 percent is 55 milliseconds, the total time is 125 milliseconds. The vertical field coil is powered by the split current of the longitudinal field; the power is activated when a switch is closed by gaseous breakdown. The rise time of the electric current is 6 milliseconds; once the current reaches the plateau region, its waveform is synchronized with the waveform of the longitudinal field.

The diagram in Figure 2 illustrates the principle of feedback power supply for the heating field coil. The energy storage condenser C_H (14 mf) supplies power to the heating field coil through two regulators connected in parallel. The operating principles of the two regulators, i.e., the linear regulator and the compensation regulator, are described below.

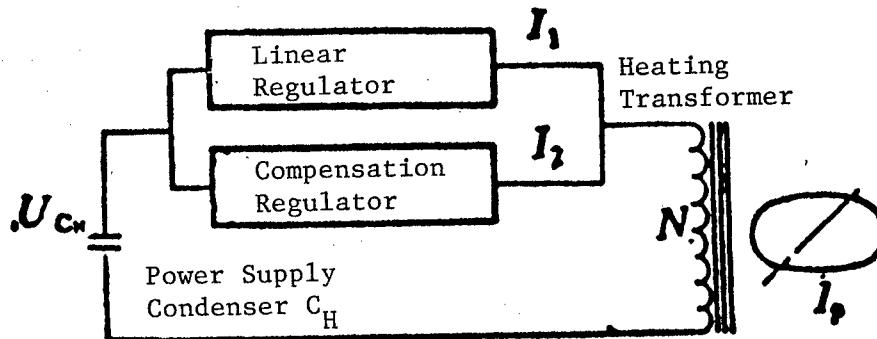

Figure 2. Principle of the Power Supply With Feedback Control of the Heating Field

The linear regulator consists of 16 fixed-bandwidth, variable-frequency choppers (which are arranged in four groups connected in series, the four choppers in each group are connected in parallel). The serial connection raises the operating voltage of the regulator. Since the maximum operating frequency of each chopper is limited by the individual components (chosen to be 1.3 kHz), operating the choppers in series can enhance the frequency response of the entire regulator. The operating frequency of the chopper is controlled by the feedback signal, hence the total current passing through the linear regulator is proportional to the feedback signal. Let

$$I_1 = -K_1(I_p - I_{po}) - K_2(I_p X - I_{po} X_o), \quad (6)$$

where K_1 , K_2 are constants of proportionality. Let the resistance of the compensation regulator be R_2 , the number of turns of the heating field transformer be N , and the voltage of the energy storage condenser be U_{CH} , then neglecting the field current of the iron-core transformer, we have

$$U_H = \frac{1}{N} U_{CH} - R_2 \left(\frac{I_p}{N^2} - \frac{I_1}{N} \right). \quad (7)$$

By substituting equation (6) and comparing with equation (1), we obtain:

$$k_1 = \frac{R_2}{N^2} + \frac{R_2}{N} K_1, \\ k_2 = \frac{R_2}{N} K_2. \quad (8)$$

Since U_{CH} decreases continuously during a discharge, it is clear from equation (7) that in order to maintain the value of U_H , the operating current of the linear regulator I_1 must be correspondingly increased. In an effort to simplify the linear regulator and to lower its cost, we used the technique of continuously reducing the resistance of the compensation regulator to compensate for the decreasing U_{CH} . The compensation regulator consists of 17 resistors connected in series; 16 of the resistors are each connected in parallel to a thyristor. When the output current of the linear regulator approaches saturation, a thyristor will be shorted, thereby eliminating one of the resistors of the compensation regulator. Under normal operation, the operating voltage of the linear regulator is approximately 3,000 volts, the maximum operating current is 18 amps, and the maximum operating frequency is 20 kHz. When the range of current regulation is 20 times, the effective frequency response is 1 kHz.

The experimental results are recorded by a waveform recorder, which has a maximum recording speed of 1 MHz and a precision of 6 bits.

Preliminary Experimental Results and Discussion

The initial experiments were conducted under the following conditions: the longitudinal magnetic field is approximately 9,000 Gauss; the plasma current

is approximately 25,000 amps; the number of turns of the transformer is 240; and the initial resistance of the compensation regulator is 16 ohms. The feedback is initiated 10 msec to 12 msec after the discharge begins, or when the electric current reaches its maximum value. The values of I_{p0} and X_0 in the experiment are chosen to be the values of I_p and X at the beginning of feedback. This ensures that the plasma current and displacement after feedback begins will not undergo abrupt changes. The preliminary experimental results are as follows:

(1) Under the condition of a constant vertical field, the feedback control experiments have produced desirable results. Figure 3a shows typical variations in the parameters and the vertical field under feedback control. The corresponding feedback coefficients are $k_1 = 0.0025$ volt/amp and $k_2 = 0.016$ volt/amp-m. By comparing with the experimental results without feedback control as shown in Figure 3b, it can be seen that in the absence of feedback control, disturbances in the parameters, particularly moderate variations in the electric current caused by the dropping voltage of the condenser, U_{CH} , will produce large displacement of the plasma, and ultimately cause the plasma to vanish. However, with feedback control, 40-45 milliseconds after control is initiated, variations of electric current in the plateau region of the vertical field is less than 5 percent, and changes in displacement are controlled to within 1 cm. The fact that there is no apparent disturbance in the waveform of the ring voltage indicates that the plasma is macroscopically stable.

(2) In the above experiment, the values of k_1 , k_2 are consistent with the results of the stable region shown in Figure 1. Due to the limited output power of the linear regulator, we could not operate at larger values of k_1 , k_2 to prove the theory of Figure 1. But preliminary experimental results show that feedback control far away from the stable region is unstable (e.g., $k_1=0$ or $k_2=0$), and long-term stability of plasma current and displacement as shown in Figure 3a cannot be achieved.

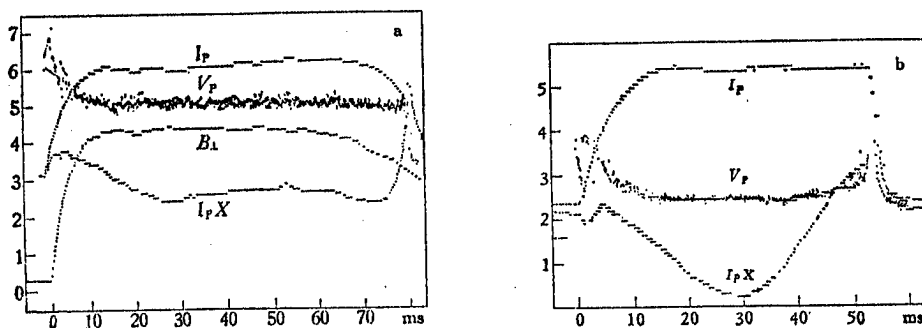

Figure 3. Parameter variations in vertical field with and without feedback control.

(3) It can be seen from Figure 3a that when discharge continues for 60-65 milliseconds, the externally applied vertical field begin to drop. Subsequently, large disturbances in plasma current and displacement begin to appear, resulting in loss of control; eventually, the plasma vanishes. This is consistent with theoretical predictions.

Acknowledgement: Thanks are due to comrades Geng Xiumin, Tang Jihui, Liu Chuncheng, and Han Gonghe for their support in conducting the experiment and to comrades Liu Peiming and He Qiuyin for supplying the waveform recorder.

3012

CSO: 4008/37

APPLIED SCIENCES

SCHEME FOR HIGH-SPEED REAL-TIME DFT OPERATION FOR RADAR SIGNAL PROCESSING*

Beijing DIANZI XUEBAO [ACTA ELECTRONICA SINICA] in Chinese Vol 12, No 1, Jan 84, pp 113-115

[Article by Su Yanguang [4725 0917 0342] and Shi Xingrong [0670 2622 2837], China University of Science and Technology]

[Text] A scheme of high-speed real-time DFT [discrete Fourier transform] operation is presented for processing radar signals. It may be used to calculate the 8, 16, or 32-point DFT. When 10 MHz clock frequency is used, the operation time per point is about 4 μ s for the complex signal input sequence of 16 bits of word-length. Under the fixed time-domain weighting adopted, it does not require more equipment or additional operation time. The control circuit is very simple. The shorter the word length of the input sequence, the faster the operation speed.

1. Introduction

This article holds that with the improvements in hardware integration and speed, replacing multiplication operations with ROM, in some cases can be done directly by adopting DFT operations. Not only can the required operational speed still be obtained, but the volume of equipment is not large and the control circuits are simple. This article explains a 15-point serial-parallel operations scheme example in combination with radar signal processing.

II. 16-Point DFT Serial-Parallel Operations

This scheme is based on a positional serial-parallel array multiplier [1]. The DFT operation finds the discrete spectrum of output sequence $\{x(n)\}$

$$X(k) = \sum_{n=0}^{N-1} x(n)W_N^{nk}, \quad 0 \leq k \leq N-1 \quad (1)$$

in which, $W_N = e^{-j2\pi/N}$, $N=16$. For the complex signal $x(n) = x_R(n) + ix_I(n)$, there is

$$\begin{aligned} X(k) = & \sum_{n=0}^{15} x_R(n) \cos \frac{2\pi}{16} nk + \sum_{n=0}^{15} x_I(n) \sin \frac{2\pi}{16} nk \\ & + i \sum_{n=0}^{15} x_I(n) \cos \frac{2\pi}{16} nk - i \sum_{n=0}^{15} x_R(n) \sin \frac{2\pi}{16} nk \end{aligned} \quad (2)$$

*Paper was received in Jul 82, and finalized in Jul 83.

The real part $x_R(n)$ and virtual part $x_I(n)$ of the input signal sequence $x(n)$ can be expressed as binary complementary code:

$$x_R(n) = \sum_{j=b-1}^1 2^{-j} x'_{Rn} - x''_{Rn}, \quad x_I(n) = \sum_{j=b-1}^1 2^{-j} x'_{In} - x''_{In} \quad (3)$$

in which x'_{Rn} and x'_{In} express the j th position value (either 0 or 1) of the $x_R(n)$ and $x_I(n)$ respectively, of the n th word; x''_{Rn} and x''_{In} express the sign bits; b is the word length. Substituting (3) in (2) we get:

$$\begin{aligned} X(k) = & \left\{ \sum_{j=b-1}^1 2^{-j} \left[\sum_{n=0}^{15} x'_{Rn} \cos \frac{2\pi}{16} nk \right] - \sum_{n=0}^{15} x''_{Rn} \cos \frac{2\pi}{16} nk \right\} \\ & + \left\{ \sum_{j=b-1}^1 2^{-j} \left[\sum_{n=0}^{15} x'_{In} \sin \frac{2\pi}{16} nk \right] - \sum_{n=0}^{15} x''_{In} \sin \frac{2\pi}{16} nk \right\} \\ & + i \left\{ \sum_{j=b-1}^1 2^{-j} \left[\sum_{n=0}^{15} x'_{In} \cos \frac{2\pi}{16} nk \right] - \sum_{n=0}^{15} x''_{In} \cos \frac{2\pi}{16} nk \right\} \\ & - i \left\{ \sum_{j=b-1}^1 2^{-j} \left[\sum_{n=0}^{15} x'_{Rn} \sin \frac{2\pi}{16} nk \right] - \sum_{n=0}^{15} x''_{Rn} \sin \frac{2\pi}{16} nk \right\} \end{aligned} \quad (4)$$

From (4) we know that if we use two memories (ROM) to store C_k and S_k separately:

$$C_k = \sum_{n=0}^{15} x'_n \cos \frac{2\pi}{16} nk, \quad S_k = \sum_{n=0}^{15} x'_n \sin \frac{2\pi}{16} nk \quad (5)$$

addressing access from x'_n and x''_n ($0 \leq n \leq 15$), then shift adding within the overall word length ($0 \leq j \leq b-1$) ($j=0$ sign bit is reduced), and finally adding the real part of both and reducing the virtual part of both, we can obtain a value $X(k)$.

Considering that the ROM demanded in (5) is too great (C_k and S_k each have 2^{16} words, requiring 16 address channels), actually 4 ROMs can be substituted:

$$\left. \begin{aligned} C_{k1} &= \sum_{n=0}^7 x'_n \cos \frac{2\pi}{16} nk, & C_{k2} &= \sum_{n=8}^{15} x'_n \cos \frac{2\pi}{16} nk \\ S_{k1} &= \sum_{n=0}^7 x'_n \sin \frac{2\pi}{16} nk, & S_{k2} &= \sum_{n=8}^{15} x'_n \sin \frac{2\pi}{16} nk \end{aligned} \right\} \quad (6)$$

C_k and S_k are obtained from $C_{k1} + C_{k2}$ and $S_{k1} + S_{k2}$, thus converting one large capacity ROM into two small capacity ROMs (number of addresses is reduced from 2^{16} to 2^8). To facilitate execution of immediate addition and subtraction operations, these ROMs should access two's complement output.

An outline of the use of this method for DFT operations is illustrated in Figure 1. First of all, the complement input signal sequence $x(n)$, $0 \leq n \leq 15$ and

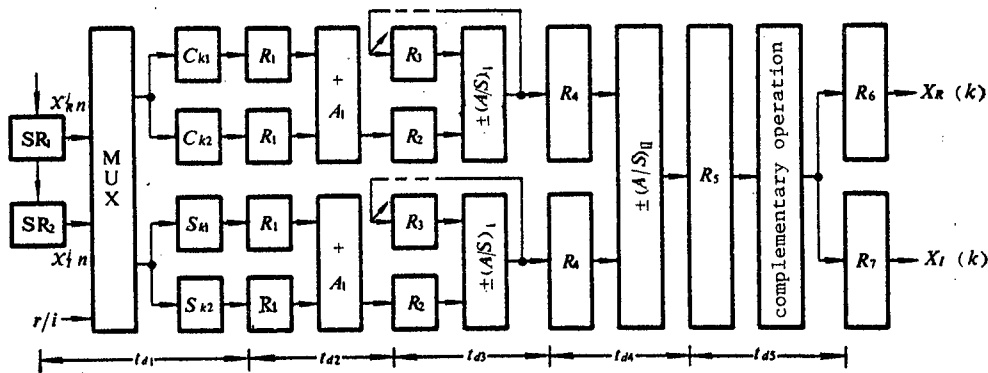

Figure 1. DFT Operations Block Diagram

store it in the shift register SR. This method uses two parallel input-serial output shift registers SR_1 and SR_2 to store the real part $x_R(n)$ and the virtual part $x_I(n)$ respectively of $x(n)$.² With the arrival of the shift clock, beginning with the lowest bit of j , x_R^f and x_I^f of different values of n are simultaneously sent to the data selector MUX. When the real part of $X(k)$ is computed, x_R^f is sent to C_{k1} and C_{k2} addresses, and x_I^f is sent to S_{k1} and S_{k2} addresses through the control signal r/i ; when the virtual part of $X(k)$ is computed, x_I^f is sent to S_{k1} and S_{k2} addresses, and x_R^f is sent to C_{k1} and C_{k2} addresses. The C_{k1} and S_{k1} addresses are always controlled by the j th bit of the first 8 numerical data ($0 \leq n < 7$), and C_{k2} and S_{k2} addresses are always controlled by the j th bit of the last 8 numerical data ($8 \leq n < 15$). After being loaded through register R_1 , the outputs of ROM C_{k1} , C_{k2} , S_{k1} , and S_{k2} are added in two adders A_1 to get C_k and S_k , then hard wired right shift addition is carried out in the two registers R_2 and R_3 and adder-subtractor $(A/S)_1$ with the ascension of data j -bit (the final sign bit is subtracted). This means that after the data of b -bit word length has been completely shifted to the shift registers, in two clock beats, the two real or virtual parts in (4) can be obtained. Then, the two real parts are added and the two virtual parts are subtracted through the register R_4 and the adder-subtractor $(A/S)_{II}$, and finally the complement is derived. In this way, the original code of real part $X_R(k)$ of $X(k)$ can be stored in register R_6 and the original code of virtual part $X_I(k)$ of $X(k)$ can be stored in register R_7 . After that, the amplitude circuit can be found, i.e., the amplitude value $|X(k)|$ can be obtained.

Thus, using the method outlined in this paper, as long as the component transmission delay time between the various level registers in Figure 1 is less than clock cycle T_{cp} , through time $2(b+4)T_{cp}$ a complex number spectral point $X(k)$ can be obtained. If the clock frequency of 10MHz, $b=16$ is adopted, then one spectral point can be obtained in 4.0 μ s. When the value of k is different, the component and structure of the operations circuit (from ROM to R_6 , and R_7) is the same, only the memory is different. Thus, if the operational time demanded permits, the serial-parallel scheme can be adopted. When the ROM is of even greater capacity, the C_{k1} , or C_{k2} , S_{k1} , S_{k2} of many k values can be stored in one ROM. For example, if actual operation time of $t \geq 16 \mu$ s, is permitted, then the C_{k1} , C_{k2} , S_{k1} and S_{k2} of four different k values can be stored in a 1024 word ROM and four $X(k)$ values can be output serially.

Table 1 sets out the estimate of the components needed for the input and operations part for this method.

Computer simulations demonstrate that, in comparison of this scheme of operation with DFT and FFT operations of similar word lengths, errors are within a few per thousand.

Table 1 Estimate of Numbers of Components Needed for the Input and Operations Parts for This Scheme

| | Type | Number (units) |
|-----------------|---------------------------------------|----------------|
| input part | shift registers, PISO, 8-bit | 64 |
| | data selector, 4 circuit, 2 selects 1 | 8 |
| operations part | PROM, 1024x8 | 8 x 4 = 32 |
| | registers, 8-bit | 26 x 4 = 104 |
| | ALU, 4-bit | 12 x 4 = 48 |
| | look-ahead carry generator, 4-bit | 3 x 4 = 12 |
| | full adders, 4-bit | 12 x 4 = 48 |
| | original NOT gate, 4-bit | 4 x 4 = 16 |
| total | | 332 |

Using the method described in this paper for time-domain weighted processing does not require additional hardware nor does it take additional time, and requires only changing the ROM capacity. This is because after time-domain weighting

$$X(k) = \sum_{n=0}^{15} x(n)w(n)W_N^{nk},$$

$$0 \leq k \leq 15$$

in which $w(n)$ is the weighting function. At this time it is only necessary to take

$$C_{k1} = \sum_{n=0}^7 x'_n w(n) \cos \frac{2\pi}{16} nk, \quad C_{k2} = \sum_{n=8}^{15} x'_n w(n) \cos \frac{2\pi}{16} nk$$

$$S_{k1} = \sum_{n=0}^7 x'_n w(n) \sin \frac{2\pi}{16} nk, \quad S_{k2} = \sum_{n=8}^{15} x'_n w(n) \sin \frac{2\pi}{16} nk$$

III. Conclusion

This method can be used in cases of DFT real-time operations when the operation point numbers (such as 4, 8, 16, and 32 points) are not numerous.

1. The time for carrying out DFT operations on complex signals using this scheme is $T=2a(b+c)T_{cp}$, in which a is the serial operation point number of each circuit, b is the length of the input signal sequence, c is the number of register levels of the operational part, T_{cp} is the clock cycle, the 2 represents one operation each of the real and virtual parts.

2. This scheme is readily converted for 4, 8, and 32 point operations but the circuit structure of the parts is basically unchanged. Thus, this scheme has a definite general purpose nature and is easy to design, install, and maintain.

3. When doing time-domain weighting processing, it is not necessary to add hardware nor does it take additional time, and requires only changing the ROM capacity.

References

Bede Liu and A. Peled, DIGITAL SIGNAL PROCESSING, John Wiley & Sons, 1976, Chapter 5.

8226

CSO: 4009/30

APPLIED SCIENCES

ON H PLANE DIELECTRIC LOADING THEORY FOR H PLANE FERRITE PHASE SHIFTER

Beijing DIANZI XUEBAO [ACTA ELECTRONICA SINICA] in Chinese Vol 12, No 1 Jan 84
pp 116-119*

[Article by Wen Junding [3306 0193 7844], Nanjing Institute of Ship Radar]

[Text] Abstract: The theoretical and experimental results of a nonreciprocal H plane dielectric-loaded H plane ferrite phase shifter are presented, including the approximate formula of differential phase shift and the transcendental equation of differential phase shift frequency response with zero slope. The results show that this kind of dielectric-loaded technique makes it possible to increase the differential phase shift and the figure of merit, and fabricate devices with wide band and higher average power.

I. Basic Theory

Document [1] gives a brief description of the improved BeO dielectric-loaded performance, but it does not have specific results and theoretical analysis. The H plane dielectric-loaded structure of a non-reciprocal phase shifter studied in this article is illustrated in Figure 1. Because its boundary conditions are complex, it is extremely difficult to give a strictly analytical solution [2]. However, after normalizing the field amplitude of an LSM mode x direction partial interstitial dielectric guide, while satisfying the conditions of continuous tangential magnetic field vector of dielectric and air interface (t+th) and ferrite and dielectric interface t, the electromagnetic field vector is determined, the amplitude coefficient of the ferrite chip and the air waveguide field outside of the dielectric chip are viewed as the TE_{10} primary mode field, and applying traditional perturbation formula, the differential phase shift of the device being researched can be approximated.

Supposing the relative dielectric constant of the ferrite is ϵ_r , the magnetic conductivity is μ_0 , it is easy to write the LSM mode field expression ($0 \leq z \leq t$) for this region.:

(see following page)

* Paper was received in Sep 82, and finalized in Mar 83.

$$\begin{aligned}
E'_x &= C \sin \frac{\pi x}{a} \cos K_1 z e^{-1\beta_0 y} \\
E'_y &= -\frac{k_1 \pi}{k_0^2 a} C \cos \frac{\pi x}{a} \sin K_1 z e^{-1\beta_0 y} \\
E'_z &= j \frac{k_1 \beta_0}{k_0^2} C \sin \frac{\pi x}{a} \sin K_1 z e^{-1\beta_0 y} \\
H'_x &= \frac{\beta_0 \epsilon_1}{\omega \mu_0} C \sin \frac{\pi x}{a} \cos K_1 z e^{-1\beta_0 y} \\
H'_y &= -j \frac{\pi \epsilon_1}{\omega \mu_0 a} C \cos \frac{\pi x}{a} \cos K_1 z e^{-1\beta_0 y}
\end{aligned} \tag{1}$$

For the electromagnetic field vector $\{t \leq z \leq (t+h)\}$ of the H plane dielectric-loaded region, we have

$$\begin{aligned}
E^D_x &= D \sin \frac{\pi x}{a} \cos K_D z e^{-1\beta_0 y} \\
E^D_y &= -\frac{K_D \pi D}{K_0^2 a} \cos \frac{\pi x}{a} \sin K_D z e^{-1\beta_0 y} \\
E^D_z &= j \frac{K_D \beta_0 D}{K_0^2} \sin \frac{\pi x}{a} \sin K_D z e^{-1\beta_0 y} \\
H^D_x &= \frac{\epsilon_D \beta_0 D}{\omega \mu_0} \sin \frac{\pi x}{a} \cos K_D z e^{-1\beta_0 y} \\
H^D_y &= -j \frac{\pi \epsilon_D D}{\omega \mu_0 a} \cos \frac{\pi x}{a} \cos K_D z e^{-1\beta_0 y}
\end{aligned} \tag{2}$$

in which

$$\begin{aligned}
K_1^2 &= \omega^2 \epsilon_1 \epsilon_0 \mu_0 - (\pi/a)^2 - \beta_0^2, & K_D^2 &= \omega^2 \epsilon_D \epsilon_0 \mu_0 - (\pi/a)^2 - \beta_0^2 \\
K_0^2 &= \omega^2 \epsilon_0 \mu_0 = (\pi/a)^2 + \beta_0^2
\end{aligned} \tag{3}$$

where $z=t+h$ and $z=t$, it is necessary to satisfy the conditions that the tangential magnetic field is continuous, then we get:

$$D = 1/\epsilon_D \cos K_D(t+h) \tag{4}$$

$$C = \cos K_D t / \epsilon_1 \cos K_D(t+h) \cos K_1 t \tag{5}$$

When considering only the field vector corresponding to the primary mode, the phase constant approximation of the single chip structure of the device under study derived by the traditional perturbation formula [5] should be applied:

$$\begin{aligned}
\beta &= \beta_0 + \frac{(\mu-1) \cos K_D t}{2\pi b \beta_0 K_1 \cos K_D(t+h)} \left[\frac{\pi w}{a} \left\langle \beta_0^2 + \left(\frac{\pi}{a}\right)^2 \right\rangle \right. \\
&\quad \left. - \left\langle \beta_0^2 - \left(\frac{\pi}{a}\right)^2 \right\rangle \cos \frac{\pi}{a} (2d+w) \sin \left(\frac{\pi}{a} w\right) \right] + \frac{K \cos K_D t \operatorname{tg} K_1 t}{ab K_1 \cos K_D(t+h)} \\
&\quad \cdot \sin \frac{\pi(2d+w)}{a} \sin \frac{\pi w}{a} + \frac{\omega^2 \mu_0}{2\pi b \beta_0} \left[\frac{(\epsilon_1-1) \epsilon_0 \cos K_D t \operatorname{tg} K_1 t}{K_1 \epsilon_1 \cos K_D(t+h)} \right. \\
&\quad \left. + \frac{(\epsilon_D-1) \epsilon_0}{K_1 \epsilon_D \cos K_D(t+h)} \left\langle \sin K_1(t+h) - \sin K_1 t \right\rangle \right] \\
&\quad \cdot \left[\frac{\pi w}{a} - \cos \frac{\pi}{a} (2d+w) \sin \frac{\pi w}{a} \right]
\end{aligned} \tag{6}$$

For the twin-board structure being studied, the differential phase of the component is three times the single chip structure, thus we get:

$$\Delta\beta = \frac{4K \cos K_D t}{ab K_r \cos K_D (t+h)} \operatorname{tg} K_r t \sin \frac{\pi(2d+w)}{a} \sin \frac{\pi w}{a} \quad (7)$$

The μ , and K in the above formulas are the diagonal vector and the non-diagonal vector respectively of tensor permeability.

It must be pointed out that the above formulas are only appropriate when the ferrite chip and the dielectric chip are very thin.

In addition, when $h=0$ in formula (7), the results obtained are identical to document [3]. The difference in the theoretical and practical values of this formula is less than the traditional perturbation formula [5]. This is because although the practical ferrite chip isn't really thick, its dielectric constant is very high, turbulence to the field is rather great, and thus, it damages the perturbation conditions. Although formula (7) can be obtained under approximate conditions, it includes the parameter ϵ_f of the hidden dielectric constant. The author has made many comparisons in the C and S wave sector and verified the above conclusion. For example, carrying out the computations using the non-reciprocal 90° phase shift section parameter given in document [6], the computed value of the traditional perturbation formula is 70° but the computed value using this formula is 85° .

Deriving w using formula (7) and letting its value be zero, we obtain the transcendental equation when the slope of the differential phase shift frequency characteristic is zero:

$$\begin{aligned} & \sqrt{\mu_0 \epsilon_0 (\epsilon_D - 1)} (t+h) \operatorname{tg} \omega \sqrt{\mu_0 \epsilon_0 (\epsilon_D - 1)} (t+h) \\ & - \sqrt{\mu_0 \epsilon_0 (\epsilon_D - 1)} t \operatorname{tg} \omega \sqrt{\mu_0 \epsilon_0 (\epsilon_D - 1)} t - \frac{2}{\omega} \\ & + \frac{2\sqrt{\mu_0 \epsilon_0 (\epsilon_f - 1)} t}{\sin 2\omega \sqrt{\mu_0 \epsilon_0 (\epsilon_f - 1)} t} = 0 \end{aligned} \quad (8)$$

when $h = 0$, the results of formula (8) are identical with document [3].

II. Verification

In order to explain the practicality of formulas (7) and (8), we compared the relative increase of the component's differential phase shift before and after H plane dielectric loading. Let h in formula (7) be zero, and also divide formula (7) [?], then the relative increase of differential phase shift is

$$R = \cos K_D t / \cos K_D (t+h) \quad (9)$$

To verify the approximate practicality of formula (10) [?] we made the following experimental proof:

1. We chose a BJ-48 square wave guide, assumed $\epsilon_f = 13.5$, $4\pi M_s = 930\text{Gs}$, $t = d = 0.06309a$, $w = 0.2103a$, and when a direct current magnetic field $H_0 = 470\text{Oe}$ was applied externally, we carried out H plane loading using $h = 0, 0.03155a, 0.04206a$ and

0.05258a boron nitride chips ($\epsilon_p=4.5$). The R values obtained are shown in Figure 1. From the solid line in the figure it can be seen that as h increases, the R value rises monotonously. The broken line indicates the computed value of formula (9) under the aforementioned circumstances, its regularity of change is extraordinarily similar to the actually measured curve.

2. A comparison of the measured R value and the computed component R value within the region of $(d+0.5w) \leq a/4$ in the BJ-48 wave guide when the ferrite chip is as thin as $t = 0.05468a$, and the chip width $w=0.2524a$, $h=0.03155a$, $H_0=10400e$, $4\pi M_s = 1200G_s$ is illustrated in Figure 2. From the illustration it can be seen that when the value is fixed, relative to different $(d+0.5w)$ values, the R value changes are not great; the frequency characteristics are basically the same; and the theoretical and measured values of R conform much better than the results in Figure 1.

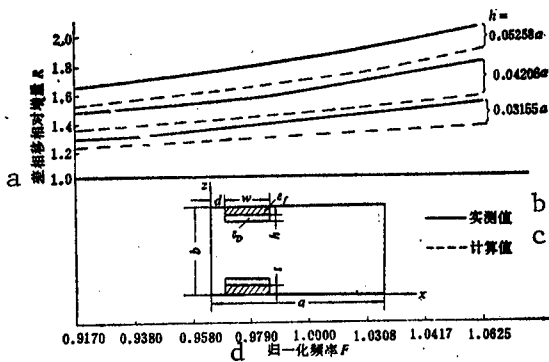

Figure 1. Comparison of Theoretical and Measured R Values.

- Key:
- a. differential phase shift relative increase R
 - b. measured value
 - c. computed value
 - d. normalized frequency F

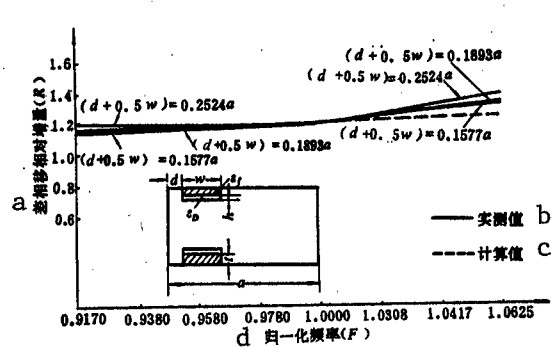

Figure 2. Comparison of Theoretical and Measured R Values

Experiments also showed that when $(d+0.5w)$ value comes close to $a/2$, the R value error increases. It appears that when the ferrite chip is in a high electric field, this method is crude and approximate. Yet, in terms of the design of the actual component, this region was not adopted.

3. Under the conditions in Figure 1, when $h=0.03155a$, the figure of merit for a right-hand polarized wave before and after loading was $223^{\circ}/dB$ and $222.8^{\circ}/dB$; for left-hand polarized waves it was $259.4^{\circ}/dB$ and $361.6^{\circ}/dB$. When h increases, for example when $h=0.04206a, 0.05258a$, the device's figure of merit decreases. Yet, when the t value in Figure 2 is reduced to $0.044164a$, the zero slope of the differential phase frequency characteristic obtained, and the

device's figure of merit may increase 20 percent. For right hand polarized wave, there is no clear change in the figure of merit. It is clear that there is a regularity to the change in figure of merit before and after H plane loading.

4. After H plane dielectric loading, when the device obtains a differential shift frequency characteristic zero slope, the ferrite chip thickness is less than before loading. For example, when $h=0$, $F=1$, $\epsilon_r=13.5$ and $\epsilon_D=4.5$, under BJ-48 waveguide conditions, we get computed $t_0 = 2.699\text{mm}$, and measured $t_0 = 2.66\text{mm}$; when the dielectric loading is with $h = 1.5\text{mm}$, the t value computed by formula (8) is 2.21mm , and the measured value is 2.1mm .

5. Within the standard $(d+0.5w) \leq a/4$ region, the differential shift frequency characteristic is clearly unrelated to H_0 and the w value. Thus, formula (8) is an approximate formula suited to engineering computations.

6. The H plane loaded dielectric cannot improve thermal conduction, and in actual use it can be combined with E plane thermal conduction dielectric loading. Tests indicate that when $d=h=0.03155a$, $t=0.044164a$, $4\pi M_s=1200\text{Gs}$, $H_0=1050\text{Oe}$, using an identical boron nitride material which is $0.03155a$ thick and $t+h$ high, carrying out E plane dielectric loading on the side which is close to the BJ-48 waveguide high electric field area, except for continuous increases in differential shift, there is no clear change in the frequency characteristic.

III. Conclusion

Tests show that the formulas presented in this paper are suited to engineering computations, when $\mu=1$ and $K=0$, the formulas given describe non-magnetic dielectric loading waveguide characteristics. H plane dielectric loading itself can improve the average power capacity of the device, and combined with E plane loading is more beneficial to thermal conduction. When the magnetic dielectric dimensions and parameters are unchanged, pure H plane membrane dielectric loading will make it easier to regulate corresponding device performance. As the ridge height of a back ridge structured H plane phase shifter increases, the severity of the differential phase shift decreases [7,8].

I thank Comrades Liu Jusong [0491 5468 2646], Jiang Xuren [5592 0650 0088], and Wang Jue [3769 3778] for the valuable opinions they offered on this paper. I thank Comrades Fang Dagang [2455 1129 4854] and Yu Xianye [0151 7359 8763] for their proposals to improve this paper.

References

- [1] M. N. Berger and B. IU. Kapilevich, RADIOTEKHNIKA, Vol 26, No 5, 1971, p 79.
- [2] R.E. Kellin [2688 2651], [ON WAVEGUIDE FIELDS], tr. br Hou Yuanqing [0186 0337 1987], Shanghai 1966.
- [3] Liu Jusong [0491 5468 2646], XIANDIA LEIDA [MODERN RADAR], Radar Technology Science and Technology Publishing House, Editorial Group, No 6, 1979, p 101.
- [4] Xu Yansheng [1776 3601 3932] and Yin Jinglin [1348 2529 2651], DIYIJIE CIXUE JI CIXING QIJIAN CAILIAO ZHUANYE XUESHU HUIYI LUNWEN XUANJI [SELECTED PAPERS FROM THE FIRST MAGNETICS AND MAGNETIC DEVICE MATERIALS ACADEMIC CONFERENCE], National Defense Industry Publishing House, 1963, p. 99.

- [5] Jiang Renpei [5592 0088 1014], Chen Qingho [7115 3237 3109], and Yu Xianye [0151 7359 8763], WEIBO TIEYANGTI GONGCHENG YUANLI [PRINCIPLES OF MICROWAVE FERRITE ENGINEERING], Radar Technology Editorial Group, Vol 1, Oct 1975.
- [6] Jiang Xuren [5592 0650 0088], ZHONGGUO DIANZI XUEHUI DISANJIE NIANHUI LUNWENJI [PAPERS FROM THE THIRD ANNUAL MEETING OF THE CHINESE ELECTRONICS SOCIETY], Nanjing, 1982 pp 141-142.
- [7] Wen Junding [3306 0193 7844], DIANZI XUEBAO [ACTA ELECTRONICA SINICA] No 3, 1979, pp 44-51.
- [8] Wen Junding, DIANZI XUEBA [ACTA ELECTRONICA SINICA] 1982, pp 103-104.

8226

CSO: 4008/30

APPLIED SCIENCES

NATION'S ACHIEVEMENTS IN HIGH ENERGY PHYSICS REVIEWED

Beijing GAONENG WULI /HIGH ENERGY PHYSICS/ in Chinese No 3, Sep 84 pp 1-6

/Article by Zhang Wenyu /1728 2429 5940/: "A Review of China's High Energy Physics in the Last 35 Years"

/Text/ High energy physics is the discipline involving the study of the internal structures and properties of microscopic particles and the laws of mutual interaction and conversion of such particles. Over the last 35 years, high energy physics has had rapid developments on the international scene. In 1949, when high energy physics was in the budding stage, physicists knew only about photons, electrons, protons, neutrons, μ and positrons, and strong interaction particles Υ mesons and strange particles were discovered only a year or two before. Accelerators (500 MeV) capable of producing Υ mesons were still in the development stage and many advanced detectors in high energy physics such as bubble chambers, spark chambers, streamer chambers, Cerenkov counters, multiwire proportional chambers, and drift chambers had not been invented. The understanding of particle physics was somewhat limited at the time. In the last 35 years, along with the development of high-energy accelerators and particle detection techniques, the understanding of high energy physics has been greatly improved. Great achievements in the last 35 years include the proposal and verification of parity nonconservation in weak interaction, the discovery of antiproton, antineutron and antihyperon, the discovery of a number of resonant particles, the proposal and verification of ν_μ and ν_e neutrinos, the CP nonconservation in K^0 decay, the discovery of Ω^- particle and the verification of the SU(3) symmetry theory, the discovery of the J/ψ particle, the discovery of heavy lepton Υ and Υ' particle, the initial verification of the W-S theory unifying the weak interaction and the electromagnetic theory, and the discovery of the intermediate vector bosons W^\pm and Z^0 . Accelerators--the tools of high energy physics--have evolved into 6 km, 800 GeV proton accelerators, 2x31.5 GeV proton-proton colliders, 2x270 GeV proton-antiproton colliders and 2x23 GeV electronic-positron colliders. Today, large detectors may weigh more than 1,000 tons and there is a large variety of detectors. Modern high energy laboratories are equipped with the most advanced high speed large memory computers. It is recognized now that hadrons may be made up of six smaller particles--quarks--and the strong interaction between them may be transmitted by gluons; leptons may also consist of 6 constituents, and the weak interaction and the electromagnetic interaction may be described by a unified field theory. Coupled with the experiments, particle theory has enjoyed rapid development and high energy physics enjoys a healthy state.

In the field of high energy physics, the situation in China is rather different from that in other developed countries. In the 35 years since Liberation, Chinese physicists have made a major effort in developing high energy physics and obtained good results in the areas of experiments, theory and accelerator development. The government has issued a first prize of the National Award Sciences (the only one in physics in the last 35 years), and one each of the second, third and fourth prizes. In the meantime, the high energy physics community also provided key personnel for priority state projects. Although achievements have been obtained in the field of high energy physics, its development has been a difficult one. On the occasion of celebrating the nation's 35 anniversary, a review of the achievements in China's high energy physics and a recount of the experience and lessons learned may be useful for future work. For the sake of presentation, we shall describe China's high energy physics development in the following five areas:

I. High Energy Accelerators

In the early 1950's, a few industrially developed nations including the Soviet Union, the United States, and some European countries made a major effort to build high energy accelerators. The world's first accelerator with an energy greater than 1 GeV--the 3GeV Cosmotron of the Brookhaven National Laboratory in the United States--was built in 1953. In 1955, the 6.2 GeV Bevatron proton accelerator was built in America, and the Soviet Union was building its 10 GeV synchronous proton phasotron. At that time China was in no position to build accelerators but realized the possible connection between the accelerator technology and application and the nuclear industry and decided to develop high energy physics. It was stipulated in China's first science development plan (approved in 1956) that a 2 GeV electron synchrotron would be built as a first step in building up China's high energy physics. Personnel were immediately put together to study the problem and a seven member group was sent to the Soviet Union to learn accelerator physics. After a 1-year effort, the group completed the physical design of a 2 GeV electron synchrotron. In 1958 China had its Great Leap Forward movement and the scale of many construction projects was increased. Some felt that the energy of the 2 GeV synchrotron was too low and the electron too limited in conducting physics experiments. A 15 GeV strong focus proton synchrotron was proposed instead and the study group was ordered to complete its design in the Soviet Union. Due to various reasons, the energy of the final plan was 12 GeV and the design was based on the 7 GeV strong focus synchrotron the Soviet Union was building at the time. The design did not take advantage of some of the new design concepts in the West. In 1959, the administration studied the plan and decided to halt the project because the scope was too large and the design performance was poor.

At that time, scientists at the Soviet Dubna Joint Institute of Nuclear Research made some major breakthroughs in the intermediate energy isochronous cyclotron. After negotiating with the Soviet Union, China decided to build a 420 MeV isochronous cyclotron. A task group was sent to the Joint Institute of Nuclear Research and the physical design was completed in about half a year after which the group returned to China to begin preparations. Unfortunately China was going through a difficult period in 1960 and the project was forced

to stop. In 1965, China pulled out of the Joint Institute and decided to establish its own high energy physics base. Based on the funds available, it was determined that a 3 GeV (later increased to 6 GeV) proton synchrotron should be built and the site selection was initiated. In 1966, the Cultural Revolution began, and the project was halted for the second time.

In 1972, Premier Zhou instructed us to treat high energy physics research as a high priority task. A planning meeting was held in 1973 in Xiangshan, Beijing, and the associated units and experts were invited to attend. A number of proposals were put forth during the meeting but it was finally decided to build a 1 GeV strong current fast pulse synchrotron. China sent a delegation to the United States in 1973 to investigate the accelerator technology. Upon returning to China, the delegation proposed a 40 GeV proton synchrotron. The design called for an intensifier to serve as an injector and the intensifier would use a proton linear accelerator as its injector. A preliminary study of the proton linear accelerator subsequently began. The project, designated No 753, was approved by Premier Zhou. The project involved difficult construction and the work suffered from frequent interference, the progress was slow. In 1976, the plan was changed to building an intensifier before building the main accelerator.

After the "gang of four" was eradicated, the high energy accelerator plan was discussed again. A high-current 30 GeV accelerator was first suggested. After recognizing that the accelerators at CERN and BNL were 28 GeV and 33 GeV, the plan was changed to a 50 GeV accelerator with a current intensity of 10^{14} /pulse. After extensive debate and study, it was generally recognized that a 10^{14} /pulse current intensity could not be achieved with the technology available and the plan was changed to 10^{13} /pulse. The initial design was completed in 1978. The unique feature of the design was that direct injection into the main accelerator would be accomplished by a 200 MeV linear accelerator and the difficulties associated with the intensifier were bypassed. After a 1-year study, it was discovered that doing away with the intensifier also had its drawbacks. The plan was therefore changed again to add a 2 GeV fast pulse intensifier with injection provided by a 90 MeV linear accelerator. The project, designed Project 87, was scheduled for completion in 1987.

Because of the national economic readjustment activities, Project 87 was put on the back burner. Discussion of the proposal began anew, and the "proton" was changed to the "electron" to suit the development line of China's current economic ability. In 1982, the construction of a 2.2 GeV positron-electron collider was formally approved. The collider and the associated detection facility and equipment to make use of the synchrotron radiation are scheduled for completion in 1988.

In brief, in the 27 years from 1956 to 1982, the high energy accelerator project was embroiled in controversy after controversy and remained "pie in the sky." Preliminary studies of the magnet, the high frequency signal, the injection, the vacuum, the automated control, and the power source finally began in the preresearch phase of Project 87. In the meantime, large shops were established and six prefabricated large halls were built. From 1949 to the 1960's, China built high voltage accelerators, electrostatic accelerators,

induction accelerators, electron linear accelerators, and synchrotrons. All these accelerators are of low energy, but the construction of such accelerators has provided the opportunity to train the personnel for the construction of a high energy accelerator. The necessary technological base has also been established. For example, the high-power velocity modulation tubes developed in the 1960's for the electron linear accelerator can now be applied directly to the 2.2 GeV collider.

II. High Energy Experiments

The high energy experiments include experimental physics, particle detectors and the necessary accessories such as fast electronics and computers. They are mutually related and yet relatively independent.

(1) High energy experimental physics

Since China has no high energy accelerators, high energy physics experiments and the training of people to conduct them are done on foreign accelerators. This can be divided into two periods.

In the first period, from 1956 to 1965, a total of 60-70 people were sent to the Soviet Joint Institute of Nuclear Research to use the 10 GeV proton phasotron to conduct physics experiments such as bubble chamber work, nuclear emulsion analysis, and the construction of spark chambers. In the early 1960's, Chinese physicists also irradiated emulsion films at the Joint Institute and conducted independent experiments in China. In their study of the inelastic interaction between high energy π^- and the nucleus, they discovered a resonance peak at 1.58 GeV. A number of research topics were studied and completed in the Joint Institute. The discovery of the anti-sigma negative hyperon by the group led by Wang Ganchang [3769 3227 2490] received the first prize of the national natural science award in 1982. Another achievement of this period is the training of a team of high energy experimental physicists.

In the second period, from 1978-1983, China sent its scientists to work in American laboratories, in DESY of West Germany, in CERN, and in KEK in Japan. After the downfall of the gang of four, China strengthened its ties with the United States and Western Europe in the high energy physics area. Two groups of scientists were sent to work with professors Samuel Ting and Mo Wei, respectively, and made contributions to the discovery of the triple jet phenomenon and to the confirmation of the W-S theory on unified weak and electromagnetic interaction. In 1979, at the initiation of T. D. Lee, China further sent dozens of scientists to work with famous experimentalists in the United States for 1-2 years on a training basis. Even though this approach can only yield limited results in experimental physics, it played an important role in the training of China's high energy experimentalists and many of the key personnel in high energy engineering have studied abroad.

(2) Development of high energy detectors

From 1956 to 1965 when China was a member of the Soviet Joint Institute of Nuclear Research, most of the funding for high energy physics were devoted to

the Joint Institute and there were essentially no development of high energy detectors in China except for the 30 cm experimental freon bubble chamber built by the Chinese Science and Technology University in 1963. In the unsettling 10 years of the Cultural Revolution, such developmental work totally stopped. In August 1969, in the plan to build a high energy, high current proton accelerator, study groups were established to develop detection equipment such as bubble chambers, streamer chambers, and counters. However, the investigation of the various types of detectors did not begin until the beginning of Project 753 in 1975. Today, China can basically handle advanced high energy detector technology.

1. Multiwire proportional chamber and drift chamber

The multiwire proportional chamber was first built by Charpak in 1968. It was high spatial and temporal resolution. The drift chamber was developed by Walenta in 1970 and it is even better than the multiwire proportional chamber. In high energy experiments, these are two important detectors.

The development of the multiwire proportional chamber in China began in 1974 at the Atomic Energy Research Institute. In 1975, the High Energy Research Institute and the Chinese Science and Technology University independently initiated multiwire proportional chamber development and achieved computer online experiments with multiwire proportional chambers. This was a major advance in the area of multiwire chamber development. Subsequently, the High Energy Research Institute for the first time applied the CAMAC standard to the multiwire chamber online readout and developed a 1m x 1m medium-sized multiwire chamber. The Science and Technology University also developed a 0.5m x 1.5m multiwire chamber and achieved online readout using nonstandard logic system. In 1977, the High Energy Research Institute succeeded in developing small-scale multiwire drift chambers of 10cm x 10cm size and studied its characteristics. In 1979, 20cm x 20cm tunable field drift chamber was developed and in 1981 1m x 1m medium size planar drift chambers were developed. In 1983, testing of large drift chambers was achieved using cosmic ray and microprocessors.

In 1982, the High Energy Research Institute began to develop the Beijing detector and completed the initial design of the drift chamber system of the detector. Performance tests were partially completed and the drift properties of a number of gas media were studied. At the same time, work also began on developing drift chambers based on new mechanisms such as the multistep avalanche chamber and the time expansion chamber. It is fair to say that in the last 10 years good progress has been made in this area and a team of specialists on multiwire chamber and drift chamber has been formed.

2. Spark chamber and streamer chamber

The spark chamber is a high energy particle track detector developed by Fukuda and Miyamoto in 1959. In the early 1960's Chinese scientists working at the Joint Institute have participated in the development of spark chambers. In China, the development of spark chambers began in 1972 and the High Energy Research Institute produced a working spark chamber in 1973 that measured 470x450x190 mm³.

The streamer chamber is a particle detector developed on the basis of the spark chamber. China began to develop the streamer chamber in 1975 and completed the task in 1975. By the end of 1980, the major specifications of the streamer chamber have achieved or approached the standard of similar foreign units. The streamer chamber had a double gap system and a sensitive volume of $70 \times 50 \times 30 \text{ cm}^3$.

3. Scintillation counter and hodoscope

China started the development of scintillation counter relatively early and the technology has reached maturity. In high energy experiments, fast and large-scale scintillation counters in the form of hodoscopes are often needed. Good results have been obtained over the last 10 years, for example, the High Energy Research Institute has developed (1) $63 \times 30 \times 5 \text{ cm}^3$ liquid scintillation counters with a decay time of 3.1 ns and a decay length of 35 cm. The relative emissivity is 9 percent higher than the Chinese-made plastic scintillator ST 401; (2) $31 \times 25 \times 1.3 \text{ cm}^3$ plastic scintillators with a decay time of 1-5 ns, and (3) 4×4 orthogonal scintillator arrays and 8×8 orthogonal hodoscope.

4. Cerenkov counters

Cerenkov counters have long been used extensively in high energy physics experiments with very good results. China began its development of these counters in 1975. In a few years, the following two types of Cerenkov counters were developed: (1) 1.2m gas valve type Cerenkov counter capable of detecting 5-10 GeV K, π and p with a velocity resolution of 3.5×10^{-5} and a detection efficiency of almost 100 percent; (2) total absorption lead glass Cerenkov counter using Chinese-made ZF1 lead glass with a volume of $15 \times 15 \times 30 \text{ cm}^3$ and equipped with model XP2041 photomultiplier tube.

5. Time-of-flight counter

Time-of-flight counters have become widely used in high energy experiments. It consists of two scintillation counters. The international standard in time resolution has reached several tens of picoseconds for small area counters and 170 ps for large area counters. The High Energy Research Institute began the development of the time-of-flight counter in 1978 and built $100 \times 20 \times 1 \text{ cm}^3$ units with a time resolution of 350 ps. In 1982 the development of the time-of-flight counter components for the Beijing detector was underway and the time resolution has reached 200 ps.

6. Shower counter

Shower counters are important high energy particle detectors for high energy electrons and photons. China began its development of shower counters in 1982 primarily for the use in the Beijing detector. Self-quenching streamer type gas sampling shower counters are being developed. A model has already been made and is in the process of being tested.

7. Development of new detectors

To satisfy the needs in high energy experiments, new detectors other than those described above are also being developed. These include: (1) Self-quenching streamer (SQS) detector. The SQS detector was developed abroad in 1978. China began the development of the SQS detector in 1981 and produced the first batch of qualified detectors in the same year. A series of studies was made subsequently, including the SQS radiation meter, the liquefied petroleum gas particle detector and the Ag-SQS pulsed neutron detector; (2) Resistive cathode streamer tube. Here the metal tube is replaced by a plastic tube, the structure is simple, the production cost is low, the operation is safe and two-dimensional coordinate readout can be easily achieved. It may serve as a hadron energy meter or a μ detector; (3) Proportional counter array. The array may be used as a μ particle detector. Each unit consists of 15 counters made of aluminum. The counters are arranged in two layers with 7 or 8 counters per layer; (4) BGO crystal detector. In the early 1980's, a new inorganic crystal scintillator emerged on the international scene--the BGO single crystal. It received the attention of high energy workers because of its many unique features as a photon detector. In 1981, the High Energy Research Institute studied the current status and future prospects of growing BGO single crystals in China. In 1982, in collaboration with the Shanghai Institute of Silicates, a systematic investigation was made on the physical properties of Chinese-grown BGO single crystals and photon detection using these crystals. In 1983, the Shanghai Institute of Silicates succeeded in growing high quality large single crystals of BGO with good scintillation performance. The development of a BGO crystal array is currently underway; and (5) Exploration of the superconducting junction particle detectors. In the single particle detection using the Josephson effect of the superconducting junction, better energy resolution and temporal resolution may be achieved. China began working in this area in 1983. Preliminary results were obtained on the voltage pulse produced by irradiating the superconducting junction with Q particles.

(3) Fast Electronics

High-speed electronics is one of the four major components in high energy experiments. (The other three are the accelerator, the detector and the computer). The development of high-speed electronics in China is inseparable from the development of nuclearelectronics.

Shortly after the Revolution, the Modern Physics Institute of the Chinese Academy of Sciences formed a nuclear electronics group of five to six scientists. The work began in the development of voltage and current regulated power supplies, linear amplifiers, counters, rate meters and integration and differentiation discriminators. By the end of the 1950's, the nuclear electronics effort has acquired a broad base and some research results have been gradually translated into products. In 1958, the Atomic Energy Research Institute initiated a general effort to develop the nanosecond pulse technique, the multi-channel pulse technique, and spectroscopic nuclear electronics equipment. Many research results of that period received awards, including the fast neutron critical device pulse protection system, the one-shot fast pulse photographic oscilloscope, the α ionization chamber spectrometer, and the 256 channel pulse analyzer. In the late 196's, semiconductor detectors, transistors, and

integrated circuits entered the area of nuclear electronics. Four changes are worth noting: (1) High resolution γ and x spectrometers were developed, including low noise preamplifier, high precision main amplifier and baseline recovery and accumulation rejection circuits; (2) Minicomputers were introduced, the study of online computer technology has begun in the development of multi-user data acquisition and processing system; (3) in the mid-1970's, the international nuclear electronics NIM standard was introduced, preparing for the introduction of the CAMAC standard later on; and (4) Nuclear electronics technology has been applied to the development of the national economy. The history of the last 30 years strongly testifies to the important role of the nuclear electronics.

In high energy experiments, the signal acquisition and processing of interaction events must have high spatial, temporal, and amplitude resolution. With the extensive use of multiwire chambers, the number of channels will be in the tens of thousands. In order to acquire sufficient number of events, the enormous electronic system must be operated continuously and stably for as long as 1000 hours. The entire electronic system must be very large and complex and the performance must be very reliable. From a technical standpoint, high energy physics experiments will make use of the best results in the nuclear electronics area and at the same time, promote the advance of the nuclear electronics.

Since the establishment of the High Energy Research Institute in 1972 and under the promotion of Project 753, the work in the field of high-speed electronics proceeded in the following two areas: (1) In the general area of high-speed electronics, the international NIM standard was adopted and amplifiers, discriminators, coincidence circuits and time-amplitude convertors were successfully developed; and (2) the CAMAC standard was introduced. Console controllers, branching drive equipped with model 130 and 320 computers and a number of plug-ins were developed. In 1979, because of the initiation of Project 87, an electronics research laboratory was formed in the High Energy Research Institute. In a few years, a series of NIM fast electronics plug-ins were completed. Drift time readout circuits and multiwire chamber readout circuits were developed and investigations of the intelligent CAMAC plug-ins have begun. TRS-80 microcomputer interface and support systems were completed. The progress since 1982 has been particularly good. Extensive work has begun on the drift chamber readout system, the time-of-flight counter readout system, the shower counter readout system, the μ -counter readout system, multiple switching A/D converters, the CAMAC console interface, trigger selection logic circuits, the condition parameter monitor system, the detector power supply, and multi-purpose testing equipments. Some have resulted in satisfactory development, others have begun test use and a number of plug-in components have been duplicated on a limited scale.

(4) Electronic computer

Computers are indispensable in high energy physics. Without computers, it would be impossible to process the huge amount of data and there would be no modern physics experiments. The computer and data process laboratory in the High Energy Research Institute was formed in 1974. A Chinese made DJS-8 computer was bought, which provided general service to the Institute in 1975. The machine

was subsequently expanded and improved with additional software. After 1979, along with increased interaction with foreign countries, more and more mini-computers and microcomputers were imported and put to use and corresponding software systems were developed to support the monitoring of the detectors. The facility of the central data processing system then became inadequate. To solve this problem, a new VAX-11/780 was ordered from abroad in 1982 and should be ready for use in July 1984, eight PDP 11/23 and PDP 11/34 were in use. Since the central computer was insufficient, the M-160 machine at the Water Conserfancy Institute was also made use of. A program bank was formed and terminals will be completed to prepare for further data analysis in physics.

III. Particle Theory and Nuclear Theory

Before the Revolution, China only had a few famous theorists working abroad and there were almost no theoretical particle physicists within China. From 1952 to 1956, a few major universities cultivated a group of outstanding graduates and they began some fundamental theory research in particle physics under the guidance of older scientists. Theory work at that time concentrated mostly in the Modern Physics Research Institute and Beijing University. China joined the Soviet Joint Institute of Nuclear Research in 1956 and a number of the principal investigators in particle theory continued their work at the Joint Institute. Chinese theorists made some outstanding achievements at the Joint Institute; for example, the helicity and PCAC studies of Zhou Guangzhao /0719 0342 0664/ were at the forefront of international research. Particle theorists working in China also made some achievements. On that basis, China held its first quantum field theory workshop in Qingdao in 1958 to advance the study of quantum field theory in universities and research institutes. Theoretical work prospered in China in the following years. The major topic of study at that time was the weak interaction in the capture of μ meson by the nucleus. From 1956-1964, theories on dispersion and Regge poles were pursued. In 1965 the Biejing elementary particle group made a major effort on the straton model, participated by the Atomic Energy Institute, Beijing University, Institute of Mathematics and the Chinese Science and Technology University. This work received the second prize of the national natural science award.

The straton model was based on the quark model proposed by Gell-Mann and Zweig. The quark model treated the internal structure of hadron from a symmetry standpoint and made some major advances. On the basis of the symmetry model of hadron structure (the SU(3) model), Chinese theorists analyzed the experimental results of weak and electromagnetic interaction and proposed a relativistic straton model of hadron structure, introduced the wavefunction concept in hadron structure, and generalized the hadron center of mass motion to the relativistic case. (The motion of straton in a hadron was still treated nonrelativistically). Calculations on the electromagnetic interaction and weak interaction agreed well with experimental results. The most important feature was that seemingly unrelated processes from a symmetry standpoint were connected through the internal structure wavefunction. These achievements were highly regarded in the 1966 summer symposium held in Beijing and attended by scientists from Asia, Africa, Latin America, and Australia.

During the Cultural Revolution, research ground to a halt. Theoretical research resumed in 1974. The major subject in 1974 was the study of the new particle (J/ψ) and general analysis of the properties of the new particle was made at about the same time as the work abroad. From 1976-1980, investigations were made on the classical solution of the gauge theory--a work initiated by C. N. Yang--and differential geometry was broadly applied to gauge field theory research. This work was awarded the third prize of the national award in natural sciences in 1982. Between 1978 and 1983, the scope of research in China expanded rapidly, important achievements were made in perturbation QCD, the grand unification theory, quark and lepton structure, gluon and multi-quark states, super symmetry, super Lie group, super Lie algebra and representation, gravitation theory, and quantum field theory. Professor T. D. Lee visited China a number of times and played an important role in promoting the marriage of theory and experiment. In this period of time the number of researchers grew rapidly and established theorists can be found in almost all the major universities in China. The theoretical research in China has advanced to the cutting edge on the international scene.

Along with the development of high energy physics, the relationship between the nuclear physics and particle physics is becoming more and more intimate. In the last decade, medium and high energy nuclear physics has become an important forefront in the research of nuclear physics. In China research in this area first began in 1973 at the High Energy Research Institute. After a 10-year effort, nuclear theory groups at the Atomic Energy Institute, Shanghai Nuclear Institute and Beijing University have also initiated research in this field. Encouraging results have been obtained in super nuclear theory meson physics, nuclear force quark model theory, collision between high energy hadron and nucleus, high energy heavy ion reaction, and anomalous nuclear states. These works have built a foundation for the medium and high energy theory research in China. It should also be mentioned that major international meetings held in China, such as the 1981 Winter Workshop on nuclear physics in Beijing and the 1983 Changchun International Workshop on Nuclear Force and Nuclear Many-body theory, have all helped to promote China's particle and nuclear theory research.

IV. Cosmic Ray Research

Cosmic rays have been studied for the last 70 years and a branch of science--cosmic ray physics--was formed. Many famous Chinese scientists have made important contributions to cosmic ray research. In the study of the penetration shower, it was shown that nuclear cascade can be formed in the interaction of high energy hadron and the nucleus. Electromagnetic cascade may be produced by the two γ photons in the π^0 meson decay. In the study of μ meson absorption in a cloud chamber, it was found that μ meson had no strong interaction and it was discovered for the first time that mesonic atom may be formed in μ capture, accompanied by photon emission. Chinese cosmic ray researchers, in collaboration with foreign scholars, first obtained important results on the mass, life and principal decay modes of the V^0 particle (K_S^0 meson and Λ^0 hadron). Since there were strong academic leaders,* the research of cosmic

*In remembrance of Xiao Jian /5135 0256/ for his research in cosmic rays and for his contribution to personnel training.

ray began shortly after the Revolution. The cosmic ray group in the Modern Physics Institute was formed in 1951, and a cosmic ray experiment station was built at an elevation of 3,180 meters on Luoxueshan in Yunnan. Since 1954, this station has been equipped with a $50 \times 50 \times 25 \text{ cm}^3$ multiplate cloud chamber and a $30 \times 30 \times 10 \text{ cm}^3$ magnetic cloud chamber, and in 1957 a μ meson telescope and a neutron intensity recorder were installed to observe the intensity variation of cosmic rays. In mid-1960's, a new mountain station was built on a 3,220 meter peak of Luoxueshan. Major equipments of the new station included a large cloud chamber group consisting of a $150 \times 150 \times 30 \text{ cm}^3$ magnetic cloud chamber, a $150 \times 200 \times 50 \text{ cm}^3$ multiplate cloud chamber and a $70 \times 120 \times 30 \text{ cm}^3$ upper cloud chamber with a target. Using this equipment, extensive studies were made on high energy nuclear reactions and the generation and properties of strange particles. Systematic measurements were made to obtain the mass, life, angular distribution and momentum distribution in the center of mass system of Λ^0 and K_S^0 . The asymmetry in the angular distribution of the Λ^0 decay products was measured. And the energy dependence of the Λ^0 hyperon and K_S^0 meson ratio was also measured. During the Cultural Revolution, the study of anomalous electromagnetic shower continued, using small multiplate cloud chamber. In 1972, in the study of high energy phenomena in the large magnetic cloud chamber, a possible heavy mass charge particle event was observed. The mass of the particle is 12 times of that of a proton, its charge may be one unit charge or 2/3 or 1/3 fractional charge and its life is longer than 10^{-9} seconds.

In 1977 a mountain top emulsion chamber was built atop 5,500-meter-high Ganbala Mountain in Tibet. The current emulsion chamber setup consists of a 50-square-meter 300-ton iron thick chamber and an 80-ton lead thin chamber. The facility may be used in the study of 10^{14} - 10^{16} eV super high energy phenomena. This is the world's highest emulsion chamber and is comparable in size to similar foreign facilities. A collaborative effort with Japan was initiated in 1980 and five Chinese research units are participating: the High Energy Research Institute, Shanghai University, Zhengzhou University, Congqing Construction Engineering College, and Yunnan University.

In the development of the cosmic ray physics, the High Energy Research Institute has also launched balloon flights. A balloon task-force was formed in 1979 by the Atmospheric Research Institute, the High Energy Institute, the Space Center, the Shanghai Observatory, and the Guangzhou Electronics Institute. In 1981, a $30,000 \text{ m}^3$ balloon was launched with a payload of 190 kg. The flight altitude was 35-36 km and the horizontal flight time was 11 hours. In September 1981, a γ -ray pulsar telescope was brought to an altitude of 34 km and measured the γ x-ray background above Beijing. In May 1982, another $30,000 \text{ m}^3$ balloon was launched carrying detectors to study the charge of primitive cosmic rays and their interaction with aluminum nucleus. On 23 May 1984, a $50,000 \text{ m}^3$ balloon carrying a hard X-ray telescope detected the hard X-ray from the Crab Nebula. This was the first Chinese observation of high energy hard X-rays from space.

In addition, a small-scale extensive air shower array containing 10 scintillators was built and the Congqing Construction Engineering College also built a small underground μ meson detection facility. In recent years Shandong University has developed a complete laboratory for emulsion measurements and has obtained

encouraging results. The vertical and horizontal intensities of muons at 3,220 meters have been measured, as well as the vertical current intensity of muons at sea level. The current intensity ratio of the proton of nonadjoined hadrons and Υ meson has been determined. A antiproton and proton current intensity ratio in 10-25 GeV/c cosmic ray was measured. Showers caused by electrons, Υ photons and hadrons at an energy greater than 2 TeV were studied at an altitude of 5,500 m. Using emulsion chambers, super high energy events of large transverse momentum were observed, such events cannot be explained by today's knowledge of physics. The electronic density spectrum of extensive air shower was preliminarily measured using small extensive air shower arrays. Simulation experiments were also conducted to study the acoustic effects associated with electron and laser beams in water and bipolar and multipolar pulses were observed in the ultrasonic regime. The research of cosmic ray physics is steadily moving forward.

V. Applications of High Energy and Nuclear Technology

In 1978, a nuclear technology application laboratory was established in Zhongguan by the High Energy Research Institute. Today, the following applications are being investigated using the 2.3 MeV electrostatic proton accelerator, the 30 MeV electron linear accelerator and the 10 MeV proton linear accelerator and good results are being obtained.

(1) Ion beam analysis--Proton X-ray fluorescence analysis, backscattering, blocking effect and electron channeling effect. The scope covers mineralogy, metallurgy, archeology, semiconductor material, solid state physics, metal material, magnetism, biology, and medicine.

(2) Radiation applications-- Υ -ray damage effects, radiation modification and Υ -ray damage of space material, automatic detonation experiments of missile detonators under strong Υ -irradiation, calibration of nuclear instruments, disinfection of drugs, preservation of foodstuffs, property modification of metals by radiation, jewel and gem modification, fabrication of short-lived short-lived isotopes (C and ^{18}F , quantitative analysis of scandium by Υ activation, radioactive breeding, color center crystals for laser application, sterilization of surgical sutures, radiation chemistry (cable irradiation, relinking of polymers, and radiation biology).

(3) Physical applications--X-ray fluorescence, Mossbauer effect, applications to solid state physics, surface science, magnetism, metallurgy, geology, space, chemistry, chemical engineering, biology, medicine and archeology, specific efforts include magnetic materials, amorphous materials, petroleum geology, ocean bottom precipitates, corrosion of steel, archeology and catalysts.

(4) Neutron activation analysis--The range of application is very wide and includes industry, environmental science, bioscience, biomedical science, cosmology, mineralogy, archeology, and law. In China the Atomic Energy Institute first developed the neutron activation method and it is now being promoted throughout the country.

(5) Positron annihilation--The High Energy Research Institute first investigated positron annihilation in 1973. In 1978, a positron annihilation spectrometer with a time resolution of 250 ps was assembled and the Doppler broadening method was established. Today the technique is being used in the study of metal deformation and fracture, radiation damage, crystal defects, chemical bonds of oxides, and the aging of magnetic materials.

(6) Solid track detector--A solid track detector group was formed in 1973. The proton flux in an earth satellite capsule was first measured and the sensitivity, efficiency, and temperature dependence of proton detection by cellulose acetate and by cellulose nitrate were studied. Methods were devised to improve the sensitivity of detection of cellulose acetate. Current investigations include the fabrication of filter membrane, heavy ion identification and determination of uranium content in water.

(7) Imaging technique--In the radiation diagnosis of nuclear medicine, imaging technology has played an important role and great successes have been achieved abroad. In 1983, the High Energy Research Institute was assigned the task of developing three imaging technologies: a positron multiwire proportional chamber camera, a positron bismuth germate camera, and a nuclear magnetic resonance camera. High energy experimental techniques are being developed to serve the national economy.

(8) 10 MeV proton linear accelerator applications--Treating cancer with fast neutrons and producing neutron deficient short-lived isotopes. Recently, ^{11}C isotopes have been produced for medical diagnostic uses.

The prospects of using high energy and nuclear technologies in the national economic service are good. Where possible more efforts should be made in this area.

In addition, the popular science magazine "High Energy Physics" and the technical journal "High Energy Physics and Nuclear Physics," started in 1976 and 1977 respectively, have played indispensable role in promoting and exchanging scientific knowledge in high energy physics.

The achievements of high energy physics in China have benefited from the attention of Premier Zhou and Comrade Deng Xiaoping. With a mandate from the Party Central Committee, Comrade Fang Yi provides specific advices to the high energy endeavor. The achievements are results of the efforts by the older generation of Chinese scientists--Qian Sanqiang /6929 0005 1730/, Wang Ganchang /3769 3227 2490/, Peng Huanwu /1756 2719 2976/, Hu Ning /5170 1380/, Zhang Zongsui /1728 1350 3606/ (deceased), Zhao Zhongyao /6392 1813 1031/, Zhang Wenyu /1728 2429 5940/, He Zehui /0149 3419 1979/, Zhu Hongyuan /2612 3163 0337/, Xie Jialin /6200 1367 7792/, Xiao Jian /5135 0256/ (deceased), Li Yi /0500 0001/, Zheng Linshen /6774 2651 3932/, and Feng Xizhang /7458 6932 3864/--and the maturing generation of young scientists and engineers. Also contributing to the success is the unreserved support of the industrial departments in China and the attention and support of many foreign scientists of Chinese descent such as C. Y. Yang, T. D. Lee, C. S. Wu, S. C. Ting, C. L. Teng, and C. L. Yuan. Their contributions have had a major effect on China's development of high energy physics.

Looking back on high energy physics development in China over the last 35 years, the following experiences are worth noting:

(1) In any field, all talk and no action will not lead to progress. Over the 35 years most of the progress in high energy accelerator and experimental physics was made in the last 10 years. The first 25 years saw practically no progress because there was only talk and no action.

(2) China's high energy workers now have enough experience and technological resources to develop and build the electron-positron collider and the Beijing detector. The important thing is to strengthen organization and management, mobilize the initiative of the workers and let them develop their potential.

(3) High energy physics is an interdisciplinary basic science. On the surface it does not seem to have very much to do with the national economy, but in the long run, breakthroughs may come about in important application areas. Even technologies existing today, such as accelerators, detectors, and electronics, can already serve the national economy in many technical and production areas. Therefore, the advanced technologies employed in the development of high energy physics will definitely have an impact on China's four modernizations.

(4) Modern high energy physics experiments often use frontier technologies and often involve large-scale precision engineering. It takes time and cannot be accomplished in a hurry. In terms of expenses, the least amount of money should be spent whenever possible.

In today's situation, the high energy projects proposed (building a proton linear accelerator and a positron-electron collider and synchrotron radiation facilities in China) are practical as they tie high energy physics closely to the practical applications. In addition, we should also participate in international collaboration within our ability to keep up with the frontier research. Then, personnel will be gradually cultivated and the material basis will be established. As the nation's economic resources become richer, the pace can then be stepped up.

This review uses material provided by the associated departments. The writing and organizations were done by Wang Zhuxiang [3769 4376 5046]. The author expresses his sincere appreciation to them.

9698

CSO: 4008/27

APPLIED SCIENCES

INTEGRATED OPTICS DEVELOPMENTS OVER PAST DECADE, FUTURE PROSPECTS

Shanghai ZHONGGUO JIGUANG [CHINESE JOURNAL OF LASERS] in Chinese Vol 12,
No 4, 20 Apr 85 pp 193-196

[Article by Yu Rongjin [0060 2837 6855], Changchun Institute of Physics,
Chinese Academy of Sciences: "Review of Integrated Optics in China over
the Past Decade and Prospects for the Future"]

Abstract. This article looks back on some of the progress on guided-wave optics, fabrication and measurement of waveguides, devices, monolithic integration and microfabrication techniques in China over the past 10 years and a brief comment on anticipated trends and needs in the field of integrated optics is given.

[Text] I. Fabrication and Measurement of Waveguides

China's first research work on integrated optics began in 1974. At that time high-frequency sputtering was used to fabricate glass plane optical waveguides, prism couplers were used to measure the refractivity and film thickness of waveguides, and the fiber probe method was used to measure optical waveguide loss (2 ± 0.2 dB/cm)[1]. Later, AgNO_3 , Ti_2SO_4 , and KNO_3 fused salts were used on glass substrate to fabricate plane and rectangular optical waveguides, ion exchange was used with the help of electron fields to manufacture glass optical waveguides, and radio frequency sputtering was used on Si-SiO₂ substrate to fabricate glass plane optical waveguides. Research on niobium diffusion tantalum acid lithium optical waveguides was carried out beginning in 1975[2]. After that, the Ti diffusion method was used on LiNbO_3 substrates to fabricate optical waveguides and LiNbO_3 powder was applied to closed tubes to inhibit diffusion of Li_2O outside to fabricate optical waveguides with better performance[3]. Within a short time after work began in U.S. Bell Labs, China was using benzoic acid proton exchange on LiNbO_3 and Ti diffused LiNbO_3 substrates and the electron field enhanced salt bath method was used to place LiNbO_3 substrates in AgNO_3 (or TiNO_3) fused salts and with the addition of a DC electrical field, LiNbO_3 optical waveguides were obtained[4-6]. At the same time, polystyrene film optical waveguides were also fabricated. Considering that composite waveguides and metal electrodes are used in many actual devices, research on composite multilayered structure waveguides has also begun[7-9].

In evaluating waveguide performance and measuring waveguide parameters, prism couplers [1,10], grating couplers [11,12], and prism-grating couplers [13] have been used to measure waveguide parameters. Due to a lack of rutile prisms, other highly refractive materials (such as Zhesuanbi [7926 6808 6940] and gallium phosphide) are generally used in place of rutile to manufacture prisms [14, 15] and satisfy the needs of LiNbO_3 and other highly refractive waveguide tests. For measuring parameters of single-mode waveguides, dual polarization has been researched and proposed [16]. For measuring waveguide refractivity distribution, some methods for determining refractivity and distribution have been proposed [17-20]. In March, 1984 the "plate waveguide tester" and "model II plate waveguide tester" which the Precision Instruments Department of Tianjin University began developing in 1979 passed appraisal. The refractivity measurement error $\Delta n < 1 \times 10^{-4}$ and thickness measurement error $\Delta d < 1 \times 10^{-2}$.

In optical waveguide fabrication, mechanisms and factors which affect waveguide performance still must be studied from the microscopic angle and the quality of existing waveguides needs to be improved, such as further lowering transmission loss, improving light damage resistance of LiNbO_3 waveguides, and improving the thermal stability of proton exchange LiNbO_3 waveguides. In testing, we should improve the reliability, replicability, and precision of existing methods; measurement of waveguide (especially low loss waveguides) transmission loss is a weak link and in addition to adopting slide prism and scattering methods, we should also develop some new methods, such as, how to adopt direct temperature measuring to obtain overall waveguide loss [21] and standard tool methods now being researched abroad.

II. Waveguide Devices

After China fabricated the Ti expanded LiNbO_3 waveguide in 1979, some new waveguide photoelectric and acoustoelectric devices were developed on this material system. The waveguide photoelectric devices include waveguide photoelectric prisms [22], waveguide directional coupling modulators [23], and interference type waveguide modulators [24]. The central frequency of guide wave acousto-optic Bragg deflector already are at 330 MHz [25]. Guide wave short-range mirrors have already been fabricated of glass and LiNbO_3 materials but the problem is to find some suitable industrial techniques and technologies to improve aberrations and it is even necessary to consider studying other types of wave guide mirrors. In optical bistable devices, optical waveguide TE-TM model interference modulated optical bistable devices [26], guide wave light beam deflector bistable devices [27], and branch optical waveguide optical bistable devices [28] have been developed. Progress has been made in cyclical and variable cyclical rasters of glass and GaAs material and nonlinear effects (secondary and tertiary harmonics) in ZnS film optical waveguides [29].

III. Semiconductor Chip Integration

In semiconductor materials, the Shanghai Institute of Metallurgy and other units have worked on single chip integration centered on lasers and waveguides, with good results. A symmetrical dual mesa structured GaAs

laser-waveguide-detector or amplifier integrated circuit was manufactured using a rheotaxial GaAs-AlGaAs multilayer structured epitaxial chip and putting it through a two-step chemical corrosion process^[30]. Waveguide coupled dual mesa controllable single-mode GaAs-(GaAl)As lasers, a hidden passive waveguide integrated channel substrate plane rectangular GaAs-(GaAl)As laser and a distributed feedback dye laser have been designed and developed. Research and analysis has been conducted on metal/oxide/GaAs/AlGaAs waveguide optical characteristics and oxide buffer layer thickness selection, and the influence of different limit layers on transmission and power loss characteristics of three dimensional GaAs/AlGaAs/n+GaAs rectangular waveguides^[31].

Since they have better pattern characteristics than ordinary cleavage surface semiconductor lasers, some integrated optical semiconductor lasers, such as distributed feedback and distributed Bragg deflector semiconductor lasers, can maintain single longitude mode operation under high speed modulation. In the past, some units had a foundation in holographic grating and liquid phase epitaxy and they are not working to develop these devices.

IV. Guide Wave Optics

In addition to being a special topic in teaching in institutions of higher learning, "guide wave optics" uses different theoretical methods and numerical methods to analyze some optical phenomena and devices in dielectric waveguides and is still pretty active in China. For example, using coupling mode theory to describe prism couplers, analyzing modulation characteristics of plane optical waveguides^[32]; using characteristic matrix methods to analyze cyclical rectangular ripple waveguide^[33]; using the Green function to deduce the plate waveguide coupling mode equation, dielectric waveguide and this characteristic mode's expanded form of dielectric waveguide dyad Green function^[34]; using first order perturbation theory to process diffusion optical waveguide models of asymmetrical Gauss type refractivity distribution^[35]; using half-line optical methods to deduce the characteristic value equation of c-cut LiNbO₃ diffusion waveguide TM mode^[36];... In processing certain problems, coupling mode theory and half-line optical method are more effective. However, there are still gaps in China with regard to some theoretical methods (such as the finite element method and the fast Fourier transformation) which have already been developed internationally.

V. Microprocessing Technology

Microprocessing technology occupies a very important place in integrated optics. Combining combine their own conditions and the needs of research work China's units have carried out some research on microprocessing technology, including the adoption of ultrasonic mechanical vibration micro-cleavage technology^[37]; GaAs selective thermal oxidation^[38]; GaAs preferred corrosion; InP chemical corrosion; and ion etching and raster manufacture. In addition, research has been conducted on plane optical waveguides and optical fiber terminal face coupling technology.

VI. Prospects

Looking to the future, the development trends in the next period are:

(1) There will be advances in research on integrated optics devices, such as frequency spectrum analyzer, analog-digital and digital-analog converters, three and four element lasers and interrupters using integrated optics to the point of practicality and commercialization.

(2) Further explore the manufacturing technology and materials of devices. From development to production, technologically, they may go through the process of from simple to complex and from complex to simple. On the one hand, to meet the demands of high precision manufacturing of devices and circuits, we should develop some high precision technology (such as electron beam exposure, synchronous radiation, molecular beam epitaxy, and MOVCD); on the other hand, to suit the needs of production, we must also pay attention to creating a high performance simple technology, this is a definite stage of scientific and technological development and when handed over to large scale production the proper conditions must be present. In integrated optics, at the present time and in the coming period, the above two aspects of technology must be researched. In terms of materials, the primary materials currently are GaAs-GaAlAs, InP-InGaAsP semiconductors, LiNbO_3 and LiTaO_3 ferroelectrics and glass, and although these materials have their advantages, there are still many problems that must be solved; at the same time we should search for new materials with better futures and in addition to semiconductors and ferroelectrics, we should pay attention to some organic materials which have photoelectric functions. Improvements, explorations, and breakthroughs in materials are important problems which will determine the application and future of integrated optical devices.

(3) Conduct research on some new phenomena or important phenomena which have not yet been fully researched, especially to intensify research on optical computer components. For example, research on semiconductor room temperature, low power, ultra-high speed micro optical bistable devices, production and application of semiconductor and solid stage ultrashort optical pulse (such as submicron microsecond gates), research on new type components which have ultrahigh speed optical switches, memory, and amplification functions, and applying optical theory to research on digital and analog operations. These are primarily in reserve for optical computer and high speed optical fiber communication. In addition, improving the design of some existing devices, improving device performance, for example, the loss of bending waveguides should be reduced, length should be increased and degree of integration be reduced, there is a need for exploring new designs for this problem.

(4) Carry out integration of optical components and electrical, acoustic, and magnetic components. Many devices depend on interaction and conversion between two physical quantities (for example, the production of an injection type semiconductor laser beam and the detection, amplification, optical modulation, deflection, and switching of optical signals uses electrical-optical, acoustic-optical, and magnetic-optical interaction and conversion.) Thus, integrating the related elements in a single substrate can reduce connections and mass and increase reliability. In the past few years, much work has been done in the integration between photoelectric elements and in the future integration between elements of other physical quantities will appear.

REFERENCES

- [1] [Chinese Academy of Sciences, Jilin Physics Institute, Plate Waveguide Group, JIGUANG [LASERS], 1978, 5, No 5-6, 97. GUANGXUE JISHU [OPTICS TECHNOLOGY] 1980, No 1, 29.
- [2] [Chinese Academy of Sciences, Jilin Physics Institute, Integrated Optical Modulator Group, JIGUANG, 1978, 5, No 5-6, 97; 1979, 6, No 5, 26.
- [3] Li Yushan [2621 3768 0810] et al., KEXUE TONGBAO [SCIENCE BULLETIN], 1980, 25 No 15, 685.
- [4] Zhang Xiayang [1728 4607 2254] and Chen Yixin [71154135 2450], ZHONGGUE GUANGXUE XUEHUI DIERJIE QUANGUO JICHENG GUANGXUE XUESHU HUIYI LUNWENJI [PAPERS FROM THE SECOND NATIONAL INTEGRATED OPTICS CONFERENCE OF THE CHINA OPTICAL SOCIETY], Changchun, Sep 1978, p 54.
- [5] Zheng Jianho [6774 1696 0735] et al., [4] above p. 48.
- [6] Zhang Xiaoyang and Chen Yixin, [4] above p 56.
- [7] Hong Peizhi [3163 0160 2535] and Yu Rongjin [0060 2837 6855], ZHONGGUE JIGUANG [CHINESE JOURNAL OF LASERS], 1983, 10, No 4, 235.
- [8] Lin Shengqiang [2651 4141 1730] et al., ZHONGGUO JIGUANG, 1983, 10, No 4, 232.
- [9] Li Ruiyong [26]1 3843 6978] et al., GUANGXUE XUEBAO [JOURNAL OF OPTICS], 1984, 4, No 1, 6.
- [10] Xu Dewei [1776 1795 4850], JIGUANG, 1979, 6, No 9, 43.
- [11] Xu Dewei, WULI XUEBAO [JOURNAL OF PHYSICS], 1980, 29, No 9, 1135; GUANGXUE XUEBAO, 1981, 1, No 3 265.
- [12] Xu Mai [1776 6701] and Li Yan [2621 3601], JILIN DAXUE ZIRAN KEXUE XUEBAO [JILIN UNIVERSITY JOURNAL OF NATURAL SCIENCE], 1982, No 4, 65.
- [13] Xu Dewei, KEXU TONGBAO, 1982, 27, No 19, 1167.
- [14] Cao Zehuang [2580 3419 3552] et al., YADIAN YU SHENGUANG [PIEZO-ELECTRICITY AND ACOUSTICSL OPTICS], 1980, No 2, 94.
- [15] Huang Zhangyong [7896 4545 0516], JIGUANG, 1982, 9, No 4, 227; Huang Zhangyong et al., ZHONGGUO JIANGUANG, 1983, 10, No 11, 810.
- [16] Jin Feng [6855 6912] and Li Yushan, GUANGXUE XUEBAO, 1981, 1, No 4, 351.
- [17] Huang Zhangyong, ZHONGGUO JIGUANG, 1983, 10, No 4, 230.

- [18] Li Qu [2621 0507] et al., GUANGXUE XUEBAO, 1982, 2 No 2, 177.
- [19] Jin Feng, GUANGXUE XUEBAO, 1983, 3 No 7, 656.
- [20] Fan Junqing, GUANGXUE XUEBAO, 1983, 3 No 1, 70; DIANZI XUEBAO [JOURNAL OF ELECTRONICS], 1983, 11 No 6, 68.
- [21] J.L. Jackel, JJ. Veselka, APPLIED OPTICS, 1984, 23 No 2, 197.
- [22] Li Yushan, GUANGXUE XUEBAO, 1981, 1, No 1, 93.
- [23] Huang Zhangyong and Wu Yizun [0702 1744 1415], DIANZI XUEBAO, 1982, 10, No 6, 88.
- [24] Huang Zhangyong et al., [4] above, p 112; ZHONGGUO JIGUANG, 1984, 11, No 6, 352.
- [25] Cao Zehuang, [4] above, p 122.
- [26] Zou Lixun [6760 0500 8113] et al., ZHONGGUO JIGUANG, 1984, 11, No 5, 290.
- [27] Li Yushan et al., GUANGXUE XUEBAO, 1983, 3, no 8, 685.
- [28] Sun Yunan [1327 7183 0589] et al., GUANGXUE XUEBAO, 1984, 4, No 4, 374.
- [29] Xu Dewei et al., [4] above, p 143; Zhao Jiran [6392 4949 3544] et al., GUA GUANGXUE XUEBAO, 1984, 4, No 2, 122.
- [30] Pan Huizhen [3382 1979 3791] et al., KEXUE XUEBAO, 1981, 26, No 18, 1141.
- [31] Ma Chunsheng [7456 2504 3932] et al., [4] above, p 37; JILINDAXUE ZIRAN KEXUE XUEBAO, 1983, No 4, 67; DIANXI XUEBAO, 1984, 12, No 1, 77.
- [32] Jin Feng et al., DIANZI XUEBAO, 1982, 10, No 3, 56; Wan Lide [8001 4539 1795] and Zhu Guojun [261] 0938 6511], [4] above, p 103.
- [33] Cao Zhuangqi [2580 8369 3825] et al., YINGYONG KEXUE XUEBAO [JOURNAL OF APPLIED SCIENCE], 1984, 2, No 1, 15.
- [34] Fan Junqing et al., JILINDAXUE ZIRAN KEXUE XUEBAO, 1979, No 4, 77; Fan Junqing, GUANGXUE XUEBAO, 1981, 1, No 4, 357.
- [35] Shi Bangren [4258 6721 0117] and Wen Yushui [2429 7183 3055], GUANGXUE XUEBAO, 1984, 4, No 6, 541.
- [36] Jin Feng, GUANGXUE XUEBAO, 1984, 4, No 5, 430.
- [37] Zhang Guoyi [1728 0948 5030] et al., [4] above, p 149.
- [38] Liu Hongdu [0491 1738 1653] et al., JIGUANG, 1980, 7 No 5-6, 118.

APPLIED SCIENCES

HIGH-PRESSURE, HIGH-TEMPERATURE OPPOSED ANVIL DEVICE DESCRIBED

Beijing WULI /PHYSICS/ in Chinese Vol 14, No 1, Jan 85 pp 38-39

/Article by He Yi /0149 3015/, Wang Songtao /3769 2646 3447/, Qin Zhicheng /4440 1807 2052/, Wang Yaoji /3769 1031 1015/, and Wang Wenkui /3769 2429 7608/, Institute of Physics, Chinese Academy of Sciences: "High-pressure, High-temperature Opposed Anvil Device"/

/Text/ Static high-temperature, high-pressure technology is an important technique for researching solid state phase changes and synthesis of materials. At present, many kinds of devices are used for conducting different high-temperature, high-pressure experiments. The structure of the Bridgman type hard alloy opposed anvil is simple but it can withstand high pressure above 100kbar, and using internal heating method, the temperature can be increased to approximately 1,000^o, and the volume of the high pressure cavity is also large. For this reason, many laboratories abroad are equipped with this kind of device. To conduct research on modification of noncrystalline alloy structures, high pressures of approximately 100kbar are frequently required to obtain greater pressure effects. For this reason, we set up this high-temperature, high-pressure device.

I. Selection of Pressure Device and Design of Container

The pressure device is the source of the high pressure produced in the high pressure container. The pressure device must be structurally simple, easy to operate, increase pressure with stability, be able to maintain pressure well, and have a high degree of parallelism. On the basis of the above demands, we selected a 200t four vertical prism pressure device which we designed ourselves. The framework is of the 3-beam and 4-post type, an intermediate moving beam and framework insulating. The working platform surface is 320 x 320mm², the height of the opening is 270 mm, it uses a YQ200 oil jack to increase pressure manually, the top of the plunger is curved to maintain the parallel with the platform. The design, processing, and adjustment of this pressure device is simple and it is easy to operate. The rate of pressure increase can be controlled freely, without the momentary shock which is created in some pressure devices when first started up. When loaded to 100t, it can reach 150kbar, and at such times the pressure leakage is less than 1 percent round the clock.

The anvil device is made of domestically-manufactured YG-6 hard alloy, the diameter of the frustrum anvil surface is 20mm, the top surface and the cone form a 10° angle. The pressure anvil is protected by two layers of steel bands, the coordinated taper is 1.5° , outside the steel bands is a water jacket for water cooling when the heat is increased and at the same time protecting the bands. Figure 1 illustrates the structure of the device and the stress distribution of the steel bands.

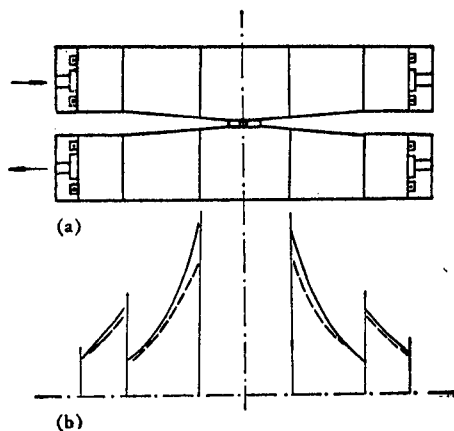

Figure 1

Key:

- (a) Structure of device
- (b) Stress distribution

- Computer value
- - - Measured value

When the container was designed the strength computations were carried out according to Hooke's law and the formula for thick-walled containers. The specific measures and the results were reported at the Second National Scientific Conference on High Pressure.

After pressure is applied to the container impedance strain is used to measure stress. The element used for measurement is a $4 \times 8\text{mm}^2$ jiaojibo $\sqrt{5231\ 1015\ 4613}$ type impedance strain chip developed by the Beijing Academy of Iron and Steel and a model YJ-5 strainmeter. Electrical measurement results indicate that the computed values and the test values conform very well.

II. Structure of the High-pressure Cavity and Production of Pressure

A disk-shaped pyrophyllite sealing pad is placed in between the opposing anvils. A hole, 5 mm in diameter is drilled in the center of the sealing pad to form a high pressure cavity. The structure is illustrated in Figure 2. The pyrophyllite seal on either end of the hole acts to insulate and relay the pressure. The internal heating element is a chip-shaped metallic heater ordinarily made of some material such as Pt or Ta which has high impedance, high temperature tolerance, and is easily shaped. Gold foil is used for the electrodes and leads, and heating is by low voltage, high current. The pressure relay medium is BN. Its internal friction coefficient is small and it can

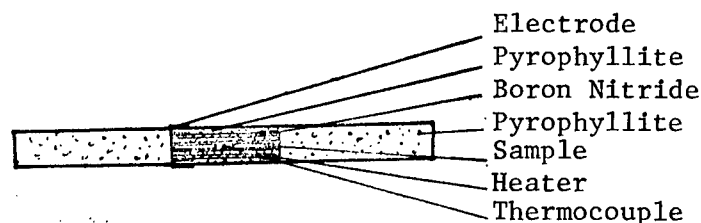

Figure 2. Structure of High-pressure Sample Chamber

improve the evenness of the pressure. The samples were close to the thermocouple hot junction to ensure the precision of temperature readings. The ordinary thermocouple is NiCr-NiSi. When temperature is increased, a DC motor driven hyperthermic transformer is used so that the temperature increase is even.

In the process of increasing pressure, the sealing pad is squeezed outwards and when the shear stress and the internal friction of the pyrophyllite and the friction between the pyrophyllite and the hardened alloy are in balance, the sealing pad stops squeezing outwards, and seals the pressure of the sample chamber and produces an increased pressure effect where the pressure in the central part is higher than the average pressure. Increased pressure effectiveness is related to such factors as the thickness of the sealing pad, and when it reaches the critical thickness, the increased pressure ratio is greatest, and when continuing to increase the thickness, the increased pressure ratio does not increase further, the critical thickness can be found by carrying out compression tests on sealing pads of different thicknesses. In this work we used domestically manufactured pyrophyllite sealing pad material which had been 1 h heat processed at 650° , and when the pressure was 100kbar, the critical thickness was about 1.6mm.

III. Pressure Adjustment

The pressure inside the high-pressure cavity was standardized using the standard pressure points of such metals as Bi and Ba. The phase change points of these metals is Bi(I-II) 25.5kbar, Ba(I-II) 55kbar, Bi(III-V) 77kbar, Ba(II-III) 120kbar. The above phase changes all are accompanied by leaps in impedance, thus pressure was checked using impedance.

When adjusting pressure, in addition to installing in the high pressure cavity heating and temperature monitoring systems and placing a silver chloride lamina around the calibrating metal to act as a pressure relay medium, all the other elements installed in the cavity were the same as in other high-temperature, high-pressure experiments, thus they could get as close as possible to use conditions. Through the electric signal extracted from the metallic foil and hardened alloy, a constant current ran through the sample, and when the pressure increased to the point that a phase change was produced in the metallic sample, there was a sharp change in the impedance, creating a change in the potential difference at the two ends of the sample. After the signal was amplified it was recorded by a domestically manufactured model LZ3-204 X-Y recorder, the X axis

of the recorder was connected to the output of a model ACY5-7 pressure sensor, and received signal of the changes in the oil pressure in the jack's oil cylinder.

From the curve of the changes in impedance of the metal sample obtained from measurement with changes in the load of the pressure device one can see the curve of the relationship of the oil pressure in the jack's oil cylinder and the pressure inside the high pressure cavity when the load was increased, as illustrated in Figure 3.

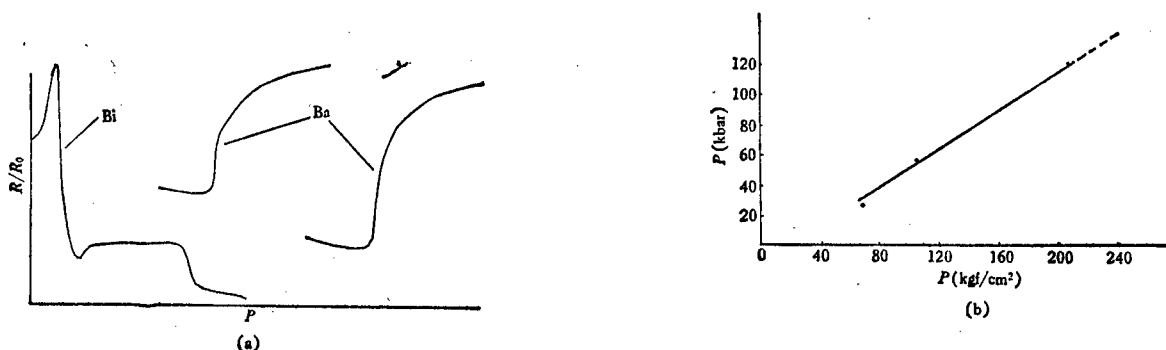

Figure 3

IV. Use of the Container

To obtain higher heating temperatures, an extremely thin metal heating chip is generally used. In addition, to prevent scattering of heat through the thermocouple wire which is very fine, thus in the process of increasing pressure it is easy to squeeze the electric couple wire into an ellipse or even break it therefore, in use pressure should be increased slowly. When the rate of increasing pressure and the rate of flow of squeezing the pyrophyllite sealing pad are uniform the heater and electric couple wire can uniformly extend distortion without affecting use, but slowing the increase of pressure can avoid mutation of pressure distribution.

Long time use shows that this device can maintain pressure without much loss, can maintain pressure for an experiment for several hours or even several days, and can operate continuously at a pressure of about 100kbar and at a temperature below 850^o which is suitable for carrying out time-related high pressure process research. If a domestically manufactured high-grade hardened alloy anvil is used, the maximum working pressure can be as high as 150kbar; if a super-thin graphite chip is used as a heating element, its useful temperature can also be increased.

Experience shows that the parallelism of the anvil base is very important to the use of the container, and it can be ensured through the design and processing precision of the pressure device beam and posts.

8226

CSO: 4008/321

APPLIED SCIENCES

APPLICATION OF COMPUTERS IN ANALYTICAL CHEMISTRY: CALCULATION OF OPTIMUM ACIDITY OF REACTION BETWEEN METAL IONS AND ORGANIC REAGENTS IN SOLUTION

Hangzhou HANGZHOU DAXUE XUEBAO (ZIRAN KEXUE BAN) [JOURNAL OF HANGZHOU UNIVERSITY (NATURAL SCIENCES EDITION) in English Vol 12 No 1, Jan 85 pp 98-102

[Article by Zhang Sunwei, Pan Fuyou, Yan Jian and Kong Fangming]

[Text]

The reactions between metal ions and organic reagents which form chelating compounds are widely used in analytical chemistry. The efficiency of chelation is related to the acidity of the reaction medium because of the competition of protons with metal ion and the tendency for the cations to become hydrolysed. The optimum acidity is generally determined experimentally. Adamovich⁽¹⁾ and Salikhov⁽²⁻⁴⁾ and others have presented the theoretical possibility of calculating the optimum acidity in such reactions and reported that the optimum pH value obtained by calculation tallies well with experimental value. It is relatively easy to establish a functional equation for treatment of the question, but it is difficult to find a solution after the values of all the parameters are substituted, because high degree equations are involved in most cases. The application of a computer can solve a number of complicated problems like the aioresaid. For this purpose we adopt BASIC language which does not demand operation and drawing-up programs. With this we arrange a program "PHZPYK-815" with which the optimum acidity in chelate formation calculated and the results are well consistent with experimental values.

Salikhov and his co-workers have pointed out that in general the reaction equation of chelate formation is

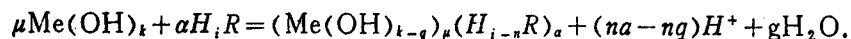

If C_M and C_R are the concentrations of metal ions and reagents, and h denotes the equilibrium concentrations of hydrogen ions, and x the equi-

Received March 22, 1984

librium concentration of chelating compound, then

$$x = [\{\text{Me}(\text{OH})_{k-g}\}_\mu (\text{H}_{i-n}\text{R})_a]$$

The formation constant of chelating compounds β is

$$\beta = \frac{[\{\text{Me}(\text{OH})_{k-g}\}_\mu (\text{H}_{i-n}\text{R})_a]}{[\text{Me}(\text{OH})_i]^\mu [\text{H}_i\text{R}]^a} = \frac{x}{\left(\sum_{k=0}^k \eta_k h^{-k}\right)^\mu \left(\sum_{i=0}^i \sigma_i h^i\right)^a},$$

$$x = \beta \left(\sum_{k=0}^k \eta_k h^{-k}\right)^\mu \left(\sum_{i=0}^i \sigma_i h^i\right)^a,$$

in which η is the overall hydrolysis constant of the metal ions and σ is the dissociative constant for the reagents. In order to find the maximal values of the function or the maximum of $[\text{H}^+] = h$ when the yield of chelated compounds is maximal, the following condition must be satisfied:

$$\left[\left(\sum_{k=0}^k \eta_k h^{-k}\right)^\mu \left(\sum_{i=0}^i \sigma_i h^i\right)^{a-1}\right]' = 0.$$

Salikhov has devised an expansion of the foregoing equation for calculating the acidity in solution when the yield of chelating compounds is maximal.

$$\begin{aligned} & (ia - k\mu + \mu g - an)(1 + \sigma_1 h + \sigma_2 h^2 + \dots) \left(1 + \frac{\eta_1}{h} + \frac{\eta_2}{h^2} + \dots\right) \\ & - a(\sigma_1 h + 2\sigma_2 h^2 + \dots) \left(1 + \frac{\eta_1}{h} + \frac{\eta_2}{h^2} + \dots\right) \\ & + \mu \left(\frac{\eta_1}{h} + \frac{2\eta_2}{h^2} + \dots\right) (1 + \sigma_1 h + 2\sigma_2 h^2 + \dots) = 0. \end{aligned}$$

With this formula, He calculates the optimum acidity in the reaction between chlorosulphophenol R and gallium. The reaction is as follows:

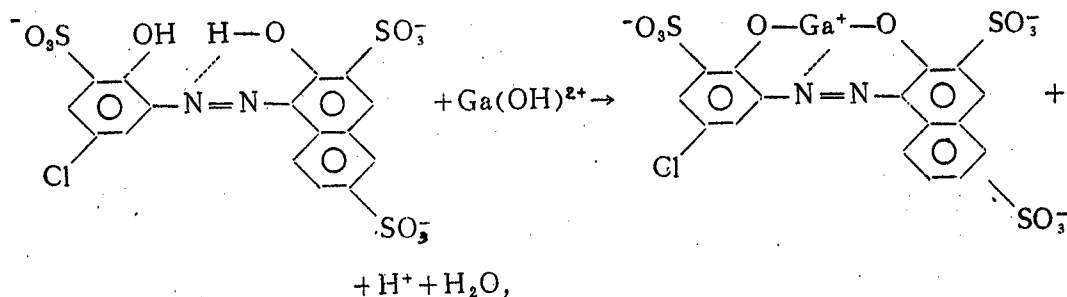

in which $i=2, k=\mu=\alpha=1$. If we take the given values σ and η into the formula, the result can be obtained as $h=2.4 \times 10^{-2}$, $\text{pH}_{\text{opt.}}=1.6$. It is report-

ed that the experimental values for this reaction is $\text{pH} \approx 1.5$, which is in good agreement with the calculated value.

The solution to this equation, assuming that the value of the optimum acidity lies in the range $\text{pH } 0-14$, can be achieved by a method of successive substitution using a simple computer program.

Let the left side of the equation be D , then the solution h satisfies the equation $D(h)=0$. To do this, the interval $[0, 14]$ is divided into several equal subintervals and the end-point of each subinterval is successively substituted in D , until its value is nearly equal to zero. In fact it is unnecessary to narrowly divide the pH value to obtain a precise value for the experimental one in actual work. From the character of the equation it can be seen that the solution of the equation must be the exterminate point of function D and its derivative will change sign in the neighbourhood of that point. For this purpose, we have programmed the "PHZPYK" procedure with BASIC language; the flow chart is as follows:

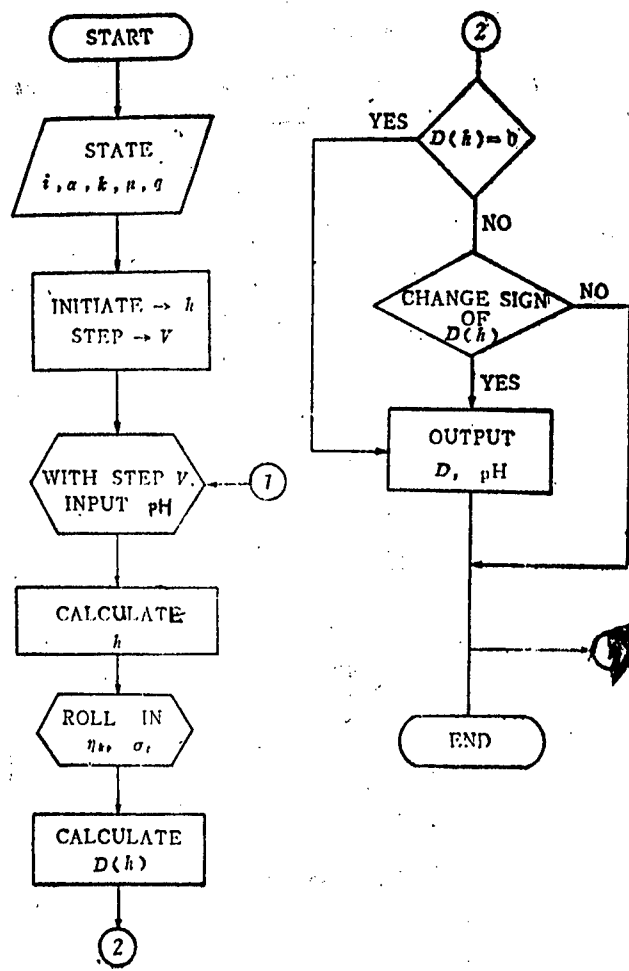

With this procedure we have computed the optimum acidity for the reaction between chlorosulphophenol *R* and gallium. The results shows that the $pH_{opt.} = 1.49$, which is closer to the experimental value pH 1.5 than that reported by Salikhov.

A coefficient 2 was found for the last term in Salikhov's formula⁽²⁾, in comparison to our derived formula⁽⁶⁾. Actually the correct formula should be

$$\begin{aligned}
 & (\alpha - k\mu + \mu q - \alpha n)(1 + \sigma_1 h + \sigma_2 h^2 + \dots) \left(1 + \frac{\eta_1}{h} + \frac{\eta_2}{h^2} + \dots\right) \\
 & - \alpha(\sigma_1 h + \sigma_2 h^2 + \dots) \left(1 + \frac{\eta_1}{h} + \frac{\eta_2}{h^2} + \dots\right) + \mu \left(\frac{\eta_1}{h} + \frac{\eta_2}{h^2} + \dots\right) \\
 & (1 + \sigma_1 h + \sigma_2 h^2 + \dots) = 0.
 \end{aligned}$$

With this formula and the procedure which we report in this paper, we calculate the optimum acidity at which chlorosulphophenol *R* reacts with Ga^{3+} ions and obtains $pH_{opt.} = 2.0$ which is rather different from the experimental result.

From Fig. 1, when $pH = 1.5$, the yield of chelate approaches the maximal value. But when $pH = 2.0$, it might be more reasonable that the yield of reaction reaches the maximal value.

With this procedure, we have calculated the optimum acidity in reactions between other organic reagents and metal ions. The results show that the value from calculation tallies well with the experimental values reported in the literature.

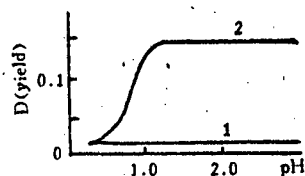

Fig.1 Comparison of the absorbance of reagent (1) and chelating compound (2) for pH, $\lambda = 570nm$, $l = 1cm$ ⁽²⁾

Acknowledgement

The author is indebted to Dr T.S. West, Director of the Macaulay Institute for Soil Research in Aberdeen, for his encouragement.

Key words: optimum acidity; organic reagent; computer; analytical chemistry

REFERENCES

- [1] Adamovich, L. P., *Zh. Anali. Khim.*, **20**(1965), 1273.
- [2] Salikhov, V. D., Yampolsky, M. Z., *ibid.*, **23**(1968), 189.
- [3] Salikhov, V.D., Dedkov, Yu.M., Yampolsky, M.Z., *ibid.*, **23**(1968), 529.
- [4] Salikhov, V. D., Tyutyunnikova, P. D., *ibid.*, **30**(1975), 1469.
- [5] Zhang, S. W., *Chemical Reagents*, 1979, 17.
- [6] Zhang, S. W., Pan, F. Y., Yao, J., Kong, F.M., *ibid.*, **4**(1982), 200.

CSO: 4010/1003

APPLIED SCIENCES

IMPROVED ALGORITHM FOR RADAR REAL-TIME DATA PROCESSING

Beijing DIANZI XUEBAO [ACTA ELECTRONICA SINICA] in Chinese Vol 13, No 1,
Jan 85 pp 127-128

[Article by Zhang Zhiben [4545 3112 2609], Electronic Technology Academy of
China: "An Improved Algorithm of Arctangent Function for Radar Real-Time Data
Processing"]

[Text] Abstract: An improved algorithm of arctangent function which needs only
two multiplication-division operations for radar real-time data processing is
presented in this paper.

I. Introduction

In radar real-time data processing, more often than not, operations of arctangent
functions are involved in order to provide an angle accuracy of half the magni-
tude of the smallest angle measurable with radar.

A basic requirement in radar real-time data processing is speed, consequently,
the number of operations of multiplication and division employed should be re-
duced to a minimum.

Generally, an arctangent function can be expanded as:

$$\operatorname{tg}^{-1}w = w - w^3/3 + w^5/5 - \dots, |w| \leq 1 \quad (1)$$

In order for formula (1) to be utilized, the plane right-angle coordinates
should be divided into 8 octants. In each octant, corresponding w values
between $0 \sim 1$ are first determined, then, formula (1) is used to calculate the
values of $\operatorname{tg}^{-1}w$ between $0 \sim \pi/4$. The results are coordinated into the corres-
ponding octant. Finally, the angle magnitudes of the arctangent between
 0 and 2π are determined.

However, when w approaches 1, formula (1) diverges very slowly. In order to
overcome this defect, the following calculation method⁽¹⁾ is used: Set

$$z(w) = \begin{cases} w, & 0 \leq w < 2 - \sqrt{3} \\ \frac{w - 1/\sqrt{3}}{1 + w/\sqrt{3}}, & 2 - \sqrt{3} \leq w \leq 1 \end{cases} \quad (2)$$

Because $|z| \leq 2 - \sqrt{3}$, Taylor's polynomial of $\text{tg}^{-1}z$ can be reduced to:

$$\text{tg}^{-1}w = \begin{cases} \text{tg}^{-1}z, & 0 \leq w < 2 - \sqrt{3} \\ \text{tg}^{-1}z + \pi/6, & 2 - \sqrt{3} \leq w < 1 \end{cases} \quad (3)$$

For example, if the smallest angle measured with radar is $2\pi/2^{14}$, since $z^7/7$ is smaller than $1/2(2\pi/2^{14})$, thus:

$$\text{tg}^{-1}z \approx z[(0.44718z^2 - 0.37271)^2 + 0.86109] \quad (4)$$

Supposing that $\text{tg}^{-1}w$ is evenly distributed in the domain of $[0, \pi/4]$, since $\text{tg}^{-1}(2 - \sqrt{3}) = \pi/6$, the probability is $2/3$ for $0 \leq w < 2 - \sqrt{3}$ and $1/3$ for $2 - \sqrt{3} \leq w \leq 1$. This indicates that an average of 4.67 and a maximum of 6 operations of multiplication-division are required to derive the arctangent function in radar real-time data processing.

In this paper, an expanded form of (2) is introduced. After expansion, formula (2) is converted into a more generalized form, out of which, an improved algorithm of arctangent function, better suited for radar real time data processing can be derived. This improvement reduces the average multiplication-division operations from 4.67 to 1.79 and the maximum number of manipulations is 2.

II. An Improved Algorithm of Arctangent Function

Formula (2) can be expanded as:

$$z = z(w) = (w - k)/(1 + kw) \quad (5)$$

where k is a constant. Since $dz/dw = (1 + k^2)/(1 + kw)^2 > 0$, $z(w)$ is a strictly monotone function of w , and $w_0 z_0 \neq -1$, the only value of k from the $z = z(w)$ curve at a certain point (w_0, z_0) as:

$$k = (w_0 - z_0)/(1 + w_0 z_0) \quad (6)$$

At this point, the result corresponding to formula (3) is written as:

$$\text{tg}^{-1}w = \text{tg}^{-1}z + \text{tg}^{-1}k \quad (7)$$

Clearly, substituting $w_0 = z_0 = 0$ into (6), we have $k = 0$, further substitutions of $w_0 = z_0 = k = 0$ into (5) and (7), give the function values of $z(w)$ and $\text{tg}^{-1}w$ in the domain of $0 \leq w \leq 2 - \sqrt{3}$. Similarly, substitution with $w_0 = 2 - \sqrt{3}$ and $z = -(2 - \sqrt{3})$ into (6), gives $k = 1/\sqrt{3}$. The function values of (2) and (3) in the domain of $2 - \sqrt{3} \leq w \leq 1$ can then be determined from (5) and (7) respectively.

The basic idea of this improved algorithm is to substitute enough sets of constant (w_0, z_0) into (5), (6) and (7), so that series of stepwise fragments thus derived approximate the curves of (2) and (3) and in each linear fragment,

$$\text{tg}^{-1}z \approx z \quad (8)$$

substituting (5) and (8) into (7) gives

$$\operatorname{tg}^{-1}w \simeq (w-k)/(1+kw) + \operatorname{tg}^{-1}k \quad (9)$$

If the smallest angle measurable is $2\pi/2^{14}$, for instance, then when $|z| < 0.083169$, therefore, $|z^3/3| < (2/2^{14})/2$, that is, the absolute value of the second term is smaller than half of the smallest angle measurable with radar. Since it is infinitesimal, thus negligible; hence, formula (8) is true. Therefore, successively using

$$\begin{aligned} w_0 = z_0 = 0, \quad k = \\ 0, w_0 = 0.083169, z_0 = -0.083169, \quad k = 0.167492, \\ w_0 = 0.254200, z_0 = -0.083169, \quad k = 0.344653, \\ w_0 = 0.440451, z_0 = -0.083169, \quad k = 0.543521, \\ w_0 = 0.656358, z_0 = -0.083169, \quad k = 0.782224, \\ w_0 = 0.925606, z_0 = 0, \quad k = 0.925606, \end{aligned}$$

to the last stepwise segment, a constant term is eliminated by setting $z_0 = 0$, so that $k = w_0$. Finally, by incorporating all these segments, we obtained:

$$\operatorname{tg}^{-1}w = \begin{cases} w, & 0 \leq w < 0.083169 \\ (w - 0.167492)/(1 + 0.167492w) + \operatorname{tg}^{-1}0.167492, & 0.083169 \leq w < 0.254200 \\ (w - 0.344653)/(1 + 0.344653w) + \operatorname{tg}^{-1}0.344653, & 0.254200 \leq w < 0.440451 \\ (w - 0.543521)/(1 + 0.543521w) + \operatorname{tg}^{-1}0.543521, & 0.440451 \leq w < 0.656358 \\ (w - 0.782224)/(1 + 0.782224w) + \operatorname{tg}^{-1}0.782224, & 0.656358 \leq w < 0.925606 \\ (w - 0.925606)/(1 + 0.925606w) + \operatorname{tg}^{-1}0.925606, & 0.925606 \leq w < 1 \end{cases} \quad (10)$$

It should be noted, the $\operatorname{tg}^{-1}k$ values have become constant and can be stored in the memory, just like any other constants.

Formula (10) shows, that calculations needed in determining $\operatorname{tg}^{-1}w$ involves only 2 multiplication-division operations at the most (average number of operations is 1.79). The results of a comparison of the improved method and the old method in radar real time data processing for radars with the smallest measurable angle of $2/2^8$ are tabulated:

| Methods | Average Number of Operations | | Maximal Number of Operations | |
|-----------------|------------------------------|----------------------|------------------------------|----------------------|
| | Multiplication - Division | Addition-Subtraction | Multiplication - Division | Addition-Subtraction |
| Old Method | | | | |
| S = 11, 12, 13 | 3.67 | 3 | 5 | 5 |
| S = 14, 15, 16 | 4.67 | 4 | 6 | 6 |
| Improved Method | | | | |
| S = 11 | 1.58 | 4.16 | 2 | 5 |
| 12 | 1.67 | 4.50 | 2 | 5 |
| 13 | 1.73 | 4.93 | 2 | 6 |
| 14 | 1.79 | 5.26 | 2 | 6 |
| 15 | 1.83 | 5.58 | 2 | 6 |
| 16 | 1.93 | 5.80 | 2 | 6 |

This improved algorithm of arctangent functions had been tested in actual data analyses and the results were satisfactory.

Acknowledgement. I thank Comrades Xu Xiaoying [6079 2556 4481] and Wang Li [3769 5461] for providing the arctangent function sub program used in this research.

12817
CSO: 4008/241

APPLIED SCIENCES

REAL-TIME APPLICATION OF OEM MODULAR 16-BIT MICROCOMPUTER SYSTEM

Nanjing DIANLI XITONG ZIDONGHUA [AUTOMATION OF ELECTRIC POWER SYSTEMS] in Chinese Vol 9, No 1 Jan 85 pp 41-44

[Article by Ye Shixun [2814 0013 8113], Nanjing Automation Institute and Xu Zhigang [1776 1807 4854], Northwest Electric Industry Management Bureau: "Real-time Application of OEM Modular 16-bit Microcomputer System; Introduction to Real-time Data Collection and Transfer in the Northwest Power Network"]

[Text] The Nanjing Institute of Automation of the Ministry of Water Resources and Electric Power obtained results in 1982 in research on the use of an M6800-series 8-bit microcomputer for implementing a real-time data collection system and successfully applied it in the Zhengzhou Power Supply Network and the Shaoshan Irrigation Area. On this foundation, we began development of applications with the INTEL Company's SBC series OEM modules and organized a real-time data collection and forwarding system centered on the SBC-86CPU module (the CPU chip is an 8086) suited to the needs of electric power network dispatching. The system includes an 8085 single-board RTU 8-bit microcomputer system which we designed ourselves. It was first installed and used in the Northwest Power Network in early October, 1983 and except for a certain number of problems that occurred with the overall power supply and individual domestically manufactured components, the system is still functioning normally. Microcomputer technology and its reliability have been welcomed by the Northwest Power Network. Below we introduce this system.

Overview

The real-time system, illustrated in Figure 1, consists of 2 16-bit microcomputers and 2 8-bit microcomputers. One 8086 16-bit microcomputer is installed at the Gansu Province Power Network Dispatch Office in Lanzhou and assembles the electricity generation parameters which are sent by the power plants in Gansu Province and after processing them displays them for the dispatcher and forwards them to the Northwest Power Network General Dispatch Office which is located in Xian. An 8086 16-bit microcomputer is also installed at the Northwest Power Network General Dispatch Office. It receives the data forwarded from the Gansu Province Power Network Dispatch Office and also collects operating parameters from the power plants in the Shaanxi Province Power Network. This 16-bit microcomputer concentrates the

real-time data of all power plants in Shaanxi and Gansu provinces and constantly displays the power network's real-time operating situation for the General Dispatch Office so that the dispatcher can know in a timely fashion the volume of power generated by the entire network (both hydro-electric and thermo-electric); the volume of hydro- and thermo-electricity generated in Gansu; the volume of hydro- and thermo-electricity generated in Shaanxi; the volume of electricity generated by each power plant, and the main operating parameters of the entire network. If a power network oil switch is tripped because of a breakdown, it is immediately displayed on the fluorescent screen, and the printer immediately records the switch number and the time of activation. This information can also be sent to the dispatch analog screen.

The RTUs, which have as their primary modules single-board computers made up of such LSI circuits as 8086 CPU chips and A/D converters, are installed in a large-sized thermo-electric plant and a medium-sized hydro-electric plant and constantly sends to the General Dispatch Office power plant operating parameters (analog quantities and switch quantities). The thermo-electric plant is situated in Shaanxi Province and since there is another thermo-electric power plant in the vicinity, both are managed by a single administrative unit and in addition to its general RTU functions, this microcomputer must also collect data from the two thermo-electric plants and after a certain amount of statistical processing, display this for the power plant's on-duty personnel. The hydro-electric plant is situated near Gansu's border with Sichuan, and after the Northwest Power Network and the Southwest Power Network are linked, the RTU can also send to the Northwest and Southwest Power Network General Dispatch Office data and information on surges on the Southwest-Northwest interconnection. Data on surges on the Southwest-Northwest interconnection can also be forwarded to the Liujiaxia Power Plant through the Northwest General Dispatch's 16-bit microcomputer so that the Liujiaxia Power Plant can directly control the size and direction of the interconnection surge. The functions described above are difficult to implement on the old equipment. The superiority of microcomputer technology is exploited in this real-time system and displays the vitality of microcomputer technology. It is not hard to see that through the application of microcomputers, real-time data transmission on the Northwest Power Network is more effective and flexible and that the structure of the real-time data network has been simplified.

Below we will briefly describe the hardware and software of this microcomputer system and the single-board RTU.

Hardware

As illustrated in Figure 1, inside the 8086 16-bit chip are 3 OEM modules connected together through a multibus:

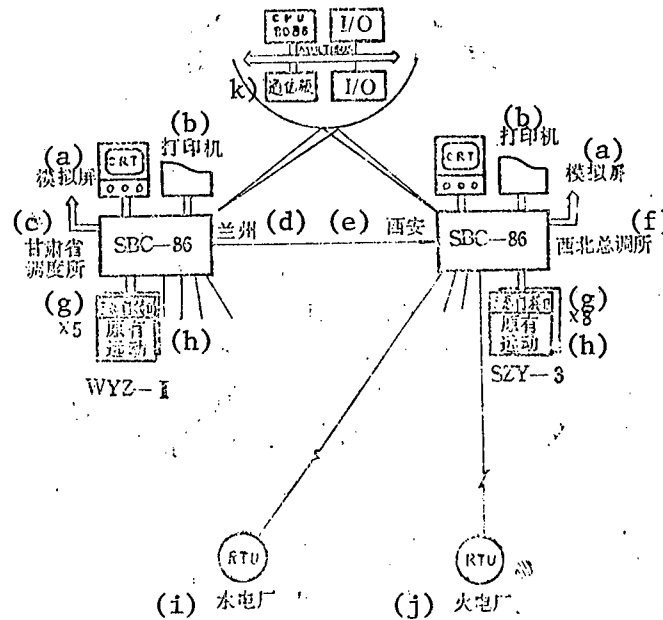

Figure 1: Outline of the Northwest Power Network's Real-time Data Acquisitions and Forwarding System

- | | |
|--------------------------|--------------------------------------|
| Key: a. analog screen | f. Northwest General Dispatch Office |
| b. printer | g. Tri-state gate interface |
| c. Gansu Dispatch Office | h. Original yuandong [6678 0520] |
| d. Lanzhou | i. Hydroelectric plant |
| e. Xian | j. Thermoelectric plant |
| | k. information source |

CPU block is an SBC-86/12A.

I/O board is an SBC-519.

Communications board is an SBC-534.

The CPU board is connected to CRT character display and printer peripheral devices; the I/O board interfaces with the original data collection device (wiring logic structured yuandong device); the communications board communicates with the remote terminals (RTU, etc.) through a modem. In the future the communications boards will gradually be increased as the system expands so that data from more terminals can be collected, displaying the flexibility and expandability of the multibus system.

The 3 OEM boards of the host computer are imported, they are highly integrated and small in size. The cabinet and the power supply were jointly designed by our office and the Changchun Electric Appliance and Meter Plant of Shanghai. Its price is much lower than the imported ones, the structure is rational, they are equipped with tiaoji [6148 2623] boards and I/O connectors and are especially suited to use in industrial control.

The SBC-86/12A boards have 8086 CPU chips, primary oscillating frequency is 5 MHz; they have shuangkou [7175 0656] 32 KB RAM, and 16 KB EPROM; one RS-232C communication port; one 8255 24-bit parallel interface; and 9 interrupt levels.

Under the SBS-519 I/O board there are 3 8255 chips with 72 bits.

On the SBC-534 communications board there is an RS-232C standard communications interface made of 4 8251 USART chips which can communicate with 4 terminals in both synchronous and asynchronous modes.

Software

In view of the fact that real-time demands of a power network data acquisition system are high, the applications program is written in ASM-86 assembly language and then loaded into the 16-bit computer system in machine code for execution.

Applications programs are primarily the following:

1. Parallel interface processing program: It responds to hardware interrupts of the original external data acquisitions devices (i.e., the yuandong devices), controls the corresponding 3-state gate interfaces, accesses data, stores it in the ready data buffer, and at the same time determines whether or not there are any changes in the switch quantity part, and if there are, it starts the print program to record the time and switch quantity number and displays them on the CRT. The parallel interface can process 16 traditional yuandong.

2. Serial interface communications program: Each full byte of the communications interface chip 8251 interrupts the CPU to access the byte. When 6 full bytes form a word, the CPU processes it. The word processing task carries out BCH check and verifies its other correctness, and isolates the data and stores it in the data buffer. Each communications board accepts 4 terminals, and the communications program processes by time-sharing the data sent from each terminal. The serial interface can handle 16 or more terminals.

3. Man-machine interface program: Including CRT and printer programs. Depending on the characteristics and demands of power network dispatching, the data collected is displayed on the CRT after processing, presently about 10 pictures have been edited, the data is renewed in the picture every 3 seconds. Each integral prints one complete set of data, and its printing can also be started manually at any time. Some data is redisplayed after a certain data process (such as summing).

4. Other programs: Including initialization and automatic recovery programs. WATCH-DOG composed of a combination of software and hardware ensures that once a program deviates from normal operation, it can recover automatically. In addition, there is the program required for debugging the machine.

Single-board RTU

The single-board RTU illustrated in Figure 2 uses an 8085A as CPU, and has 2 KB RAM and 4/8 KB EPROM for internal memory. The switch quantity is input to the 8255 I/O port through photo-electric spacing and multi-circuit switch interface; on the board there is an A/D converter, and analog quantities can be input directly; an 8279 chip connects the keyboard and data code display to perform tiaoji and local instruction functions; through 8251 communications interface chip and modem the power plant data is constantly sent to the dispatch office.

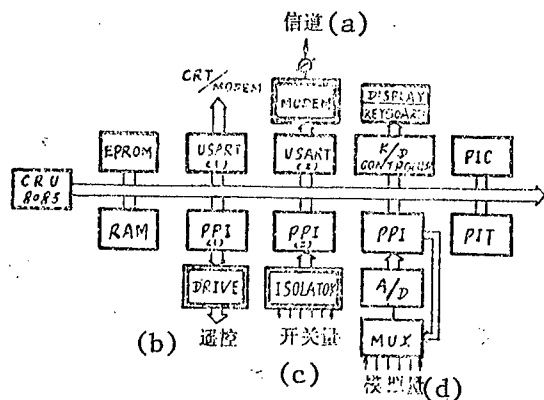

Figure 2. Outline of Single-board RTU (MWY-COI)

- Key: a. Information channel
 b. Remote control
 c. Switch quantity
 d. Analog quantity

It is not hard to see that the structure of this single-board computer is unusually compact, requiring only a modem board and photo-electric separator board to perform general RTU functions, therefore it is called a single-board RTU. The functions are more powerful than traditional RTU, for in addition to being able to handle remote communication, telemetry, remote control, and remote tiao [6148], it can also perform small forwarding functions and carry out even accident sequence recording through software.

Remote communications: 48-bit, expandable to a maximum of 256-bit/512-bit.

Telemetry: 32 or 64 circuits, expandable to a maximum of 256 circuits.

Remote control: 64 point or 128 points.

Accident sequence recording: 48

The printed circuit board measures 12 in x 6.75 in (304.8 x 171.5 mm), cabinet dimensions are 440 x 220 x 455 mm, it can be installed in an IEC standard industrial cabinet or inserted in an empty place in the sensor cabinet. After the dimensions of the RTU have been thus reduced it is easy to maintain. The printed circuit board varieties include only 3-5 zhong [6988] modems, at the smallest scale, only 3 boards are required, medium scale requires only 5 boards, thus it is not only easy of manufacture, but exchangeable cards can be used, centralizing repairs, and greatly reducing trouble shooting time. The cost of this RTU is low, manufacture and repair are easy thus it is suitable to be promoted use in numerous power plants and transformer stations. Compared with the traditional yuandong the size has been reduced to 1/5 - 1/10, price has been lowered to 1/2 - 1/4, but functions have been increased one to two fold. In short there have been clear improvements in the function/price ratio.

This RTU not only takes into account the local display and local functions required by the management practices of China's power networks, but also in terms of hardware compatibility with foreign RTU is possible, and using software techniques to implement the transparency of two different communications protocols. This is an outstanding feature of this RTU.

On the foundation of existing technical readiness, the project cycle of a system of the scale illustrated, 2 16-bit and 2 8-bit microcomputers, would only take 3 months: 1 month for machine processing, 1 month for debugging the program and the computer, and 1 month for on-site installation and debugging. Such a short development cycle is unprecedented.

The power network dispatching real-time data collection and forwarding system construction of SBC-series OEM modules of the INTEL Company's SBC-86/12A and the single-board computer designed by the Nanjing Automation Institute can be matched to a background computer to form a large-scale dispatching automation system and perform foreground computer functions; it can also perform the tasks of primary station functions independently. The Nanjing Automation Institute will apply the series of microcomputer products formed on this foundation in the Northwest Power Network, Southwest Power Network, Huabei Power Network, Huadong Power Network, and Northeast Power Network and carry out forwarding or real-time data on the above power networks to the Dispatch Center of the Ministry of Water Resources and Electric Power. At the same time the Nanjing Automation Equipment Plant, Shanghai Pujiang Electric Meter Plant, and the Shanghai Changchun Electrical Appliance and Meter Plant manufacturing units are carrying out batch production to satisfy the urgent production needs of the power networks and other businesses.

8226

CSO: 4008/1008

APPLIED SCIENCES

CHINESE CHARACTER OUTPUT FROM TRS-80 MODEL I

Shenyang XIAOXING WEIXING JISUANJI XITONG [MINI-MICRO SYSTEMS] in Chinese No 4, 8 Apr 84 pp 38-40, 31

[Article by Shu Kexin [5289 0668 1800], Computer Center, Beijing Metallurgy Jidian [2623 7193] College: "Implementing Chinese-Western Language Compatible Chinese Character Output on the TRS-80 Model I"]

[Text] With a focus on devices with graphics output capability, this paper describes a convenient method for carrying out revisions to make a system to output Chinese characters on a microcomputer.

I. Introduction

This paper explains a Chinese character transformation method and theoretically, this idea could be adapted to other machines.

Using this idea, the Chinese character processing function could be added to a great many computers which do not now have this function. Thus with slight changes in a general purpose microcomputer, processing and operations could be carried out on Chinese characters using character string format without influencing the other computing functions of the computer.

Implementation of this idea can easily produce Chinese character BASIC, FORTRAN, COBAL, assembly language, DBMS, etc. without changing (sometimes, a few changes may also be required) the original system's interpreter, compiler, assembler, and other applications software.

Experiments with a TRS-80 Model I show that this idea is feasible. Using this idea, software set up almost entirely on the original operating system can enjoy Chinese character processing resources.

II. Exploration of several transformation methods

The Chinese character processing function added to a general purpose computer should have certain hardware conditions as a foundation, for example a graphics CRT and dot matrix printer. However, a great deal

of software work is also indispensable, but here we will discuss only how to carry out the software design of Chinese character transformation where the hardware conditions obtain.

From the perspective of the user, Chinese character processing software design is generally of the following types:

1. Setting up some modules that can output Chinese characters for the user so that when he wishes to output Chinese characters so that under certain entry conditions he can call these modules to achieve his goal. This sort of software is written independently and does not influence the original system functions, but it is very inconvenient when it's time to use it. Furthermore, if one should want to process Western languages in the same way as Chinese characters (including formatted output, character insertion, deletions, searching, etc.) it is almost impossible using this method.
2. Revision of original system interpreter programs and compiler programs to achieve the goal of being able to process Chinese characters. This method creates a problem: changing the BASIC interpreter program. BASIC can process Chinese characters, but if one wants to use FORTRAN and COBOL to process Chinese characters, one must also change their interpreter programs! Although the user may feel it is easy when he is using it, the volume of software work is too great, costs can be very high, and these transformations also lower the general purpose nature of high level languages between different types of computers and to make this language a "higher level language" which is changed to rely on a certain computer hinders its promotion and application.
3. Changing the original computer into a "Chinese language computer" system. In the long view this is a very significant matter. However, in terms of the present, the volume of transformation work is enormous (including developing an entire system and applications software) even implementation on a microcomputer system might not seem worthwhile.

Among current microcomputers, most computers have pretty advanced and good operating systems and complete applications software. The weakest point in the above methods is that they cannot use these existing software resources well and to process Chinese characters it is still necessary to redesign applications software system with almost identical functions and this is a great waste both in terms of financial resources and manpower.

Summarizing the advantages of the above methods and at the same time learning from their weaknesses, we have reached a conclusion: the Chinese character transformation of microcomputers that we are presently carrying out both demands that it be easy for the user to use and that in software design there be less work and a short development cycle and, more importantly, that it should use the functions of the original system to process Chinese characters to achieve the goal of Chinese and Western language compatibility.

III. The Idea and Method of Implementing this Chinese Character Transformation

1. Relationship between Chinese character's expression inside the computer and its output form.

The Chinese character is stored inside the machine in internal coded form.

Should all parts of the system be able to recognize the internal code for the Chinese characters? Actually, this is not necessary, as long as the Chinese characters appear inside the system in the form of a unified format Western language character string, and only when this character string is sent to the output device (such as a CRT or printer) is it converted to Chinese character form. This is just the same as it is with Western language characters: inside the computer they are in code (such as ASCII code) and only when this code is sent to the output device does the character generator convert it to its character form output.

Therefore, a computer which can process Western languages also has the ability to process Chinese language information.

Of course, it is not easy to produce all Chinese character forms relying on a simple character generator method, nor is it easily developed. Our method is to use software methods to let the device (controller) "recognize" the Chinese character's internal code and convert it into Chinese character for output on the device.

2. Difference between Western language code and Chinese character code

We mentioned above that as far as the system is concerned, Chinese characters appear in the form of a Western language character string. Thus, the system can process this special Western language string just the same as it would process an ordinary Western language character string, such as insertion, deletion, and revision. But, how can the I/O device distinguish between the Western language character code and the Chinese character string code (there being no essential difference between the two codes)? The usual method is to process the Chinese character code to differentiate it from ordinary Western language code. There are basically two processing methods: one method is to use the highest bit of the Western language code and if it is set to 1 it is a Chinese character code and if it set to 0 it is a Western language code, this method should be used when the original system does not use this highest bit. The advantage is that the internal code is short--it can be 2-3 bytes, but the disadvantage is that a normal check cannot be carried out on the code in the transmission process. Because the codes above 80H in the TRS-80 Model I computer system are reserved BASIC language character codes, we did not use this method. The other method is to add a special "identification

symbol" to the Chinese character code. This character should be a non-control character in the original system character set and it is best if it is a character which is not used in the original system. It is defined as a special character which indicates a Chinese character code.

3. The transformation idea

The processing of Chinese characters inside the computer is like the processing of ordinary Western language character strings, thus whatever processing function the original system has for Western languages can be a similar processing function for Chinese characters as well, this is easy to see. This transformation idea is to utilize this point to achieve compatibility of Chinese and Western languages. What remains is the problem of how to get the Chinese character code converted into Chinese character form output. Thus we say that as long as the I/O device (controller) can reorganize the Chinese character code and can reprocess it, that will be sufficient. We need only write a Chinese character code-character form converter and make it part of the original I/O controller, especially to carry out the Chinese character output function and use the output information commands in the original system to get the devices to output Chinese characters! Doing it this way will not interfere with the other important parts of the operating system and of course have any impact on the software in the operating system.

4. Method of implementation

An operating system has a unique controller (program) entry closest to the device (corresponding to the BIOS part of CP/M and the I/O driver part in TRSDOS). Under the management of the operating system, the output information commands to the device ultimately can change into system calls for this port, and the information output definitely should go directly to the device itself through this entry device controller. We need only capture this information inside the entry as illustrated in the figure below to be able to implement the idea we discussed above and carry out the Chinese character transformation of the original system.

In the figure, the dotted lines represent the information flow in the original system, the other parts are added for Chinese character output.

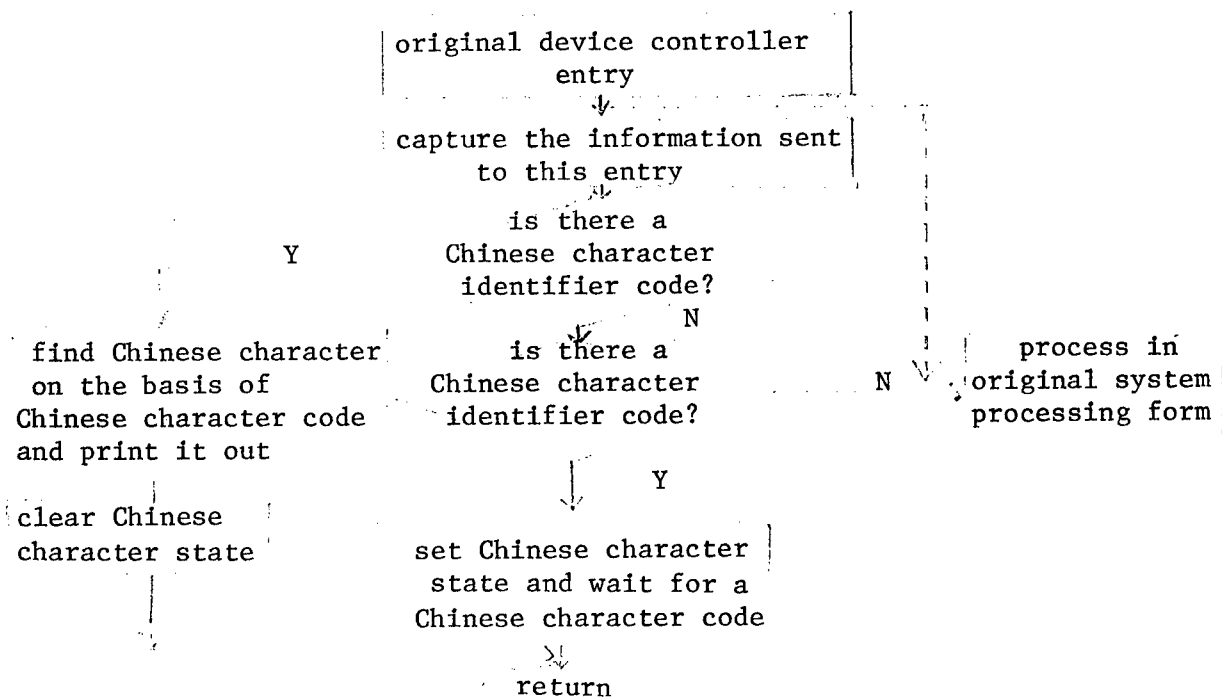

Using this way of thinking and this method, the controllers of such output devices as printers and CRTs with graphics output functions can be transformed and revised, i.e., the entire machine can be given a Chinese character processing function

IV. Specific Implementation Examples

Below, the transformation of the printer controller of a TRS-80 Model I computer is used as an example to explain the specific implementation of each part so that the reader will have a certain understanding of this detailed part so it can be implemented on other microcomputers. However, this is not the best and only method. It is hoped that it can play a role in stimulating others to come up with different schemes.

First of all, we must explain the following points:

1. The printer we used was a Japanese manufactured model 8510A. It had graphics capabilities. In terms of hardware, it is completely compatible with the original M80, therefore it was not necessary to add an interface or make other hardware changes.
2. The "Chinese character identifier" used in this system was "!". This is the least used character that can be keyed in on the TRS-80 Model I.
3. The Chinese character code was the GB2312-80 code, i. e., the national standard code.

Where we could capture and process the information sent to the printer was the key to implementing this transformation idea on the printer.

TRS-80 Model I computer printer's system call entry is 003BH, and after entering 003BH, first the current field is protected, then a device control table DCB in RAM is obtained in which the contents of each element is as in the table below:

| | TRS-80 I line printer meaning | initial value |
|---------|-----------------------------------|---------------|
| 4025H+0 | device class | 06H |
| +2 | initial driver address (low byte) | 80H |
| +3 | each page count | 05H |
| +4 | line count element | 00H |
| +5 | zero | 00H |
| +6 | [P] | 50H |
| +7 | [R] | 52H |

What we are interested in is the two elements DCB+1 and DCB+2. From the table it can be seen that the initial address of the printer device controller they make up and this address is 058DH. Since this address and the subsequent device controller are fixed in ROM it is very difficult to cover the original controller. The best method is to use a new device controller address (in the Chinese character system source program it is LPRDP) to cover up the two corresponding elements in DCB. Thus, the 003BH port system call can be automatically relayed to LPRDP to be being operation, and start from LPRDP. Then it can carry out the reprocessing of the information sent to the printer.

To reduce the amount of memory used and the volume of software work as much as possible, all the useable parts in the original device controller and the other callable subprograms in ROM are called when the new device controller is used.

Below we describe briefly the important functions and norms of this Chinese character system.

Because the high frequency characters used by each user are different, in our design we left room for an "internal high speed character library" (user definable), and the production of this character library "remembers" the Chinese characters used by the user. In addition, it can only "remember" the number of characters defined in advance. When searching, it first searches the internal character library and if it is not there, then it reads the disk, after reading, it again looks into the internal character library to see if there are still any empty spaces, and if so, it stores the character there.

The storage of the floppy disk character library (first level characters) uses the TRS-80 I's random file read/write system call, the system decides the access of transphysical records (245 bytes) of the character matrix (30 bytes), in this way saving a great deal of disk space compared to using 32 bytes or hash storage.

Because reading and writing the disk can be carried out by logical records, the corresponding relationship of the state standard code and the logical record number can be computed in the following fashion:

logical record number = (area number - 1) x 94 + (character number - 1)
If the seventy-eighth character in the second area is "(+)", the logical record number on the disk is (2 - 1) x 94 + (78 - 1) = 171

Actually it is conversion between the international code in a number base of 94 and a disk logic number in a number base of 10. High speed character search of the disk character stock is carried out in a similar fashion. If it is necessary to read the entire disk, the printer speed is about 3.3 characters/second.

For the other parts, please refer to the post-transformation system flowchart and source program. They will not be discussed here.

Below is the BNF pattern of the "Chinese character character string" in this system, and input of the "Chinese character character string" follows this pattern whether in the operating system or in a language, thus the user does not have to learn how to process Chinese characters in a language separately.

$\langle \text{Chinese character character string} \rangle := ! \langle \text{character form} \rangle \langle \text{character code} \rangle !$

$\langle \text{character form} \rangle := \text{Null} \mid + \mid - \mid * \mid /$

$\langle \text{Chinese character code} \rangle := \langle \text{Chinese character code.} \lfloor \rfloor \langle \text{GB code} \rangle$

$\langle \text{GB code} \rangle := \langle \text{area number} \rangle \langle \text{position number} \rangle$

$\langle \text{area number} \rangle := 01 \mid 02 \mid 03 \mid 09 \mid 15 \mid \dots \mid 55$

$\langle \text{position number} \rangle := 01 \mid 02 \mid 03 \mid \dots \mid 93 \mid 94$

What is output is the two words "Chinese characters" whether it is the LPRINT" ! 2626 $\lfloor \rfloor$ 5554!" in BASIC or FORMAT (1x, '! 2626 $\lfloor \rfloor$ 5554!' in WRITE in FORTRAN.

(Notes: the GB codes for "Chinese" and "character" are 2626 and 5554)

There are certainly many places where this system can be improved, and we hope that readers will offer their opinions and design an even higher quality Chinese character processing system.

In the process of designing this system, we received a great deal of assistance from Comrade Liu Jiren [0491 4480 0088] of the Northeast Industrial College and Comrades Song Wenzhang [1345 2429 4545], Li Minjian [2621 3046 1696], and Yu Zhongqiang [0060 0022 1730] of our own college. This paper was also guided and revised by Comrade Tong Longen [4547 7127 1869] of the Beijing Iron and Steel Academy. Here we would like to express our thanks to these comrades.

8226

CSO: 4008/1017

APPLIED SCIENCES

PULSED, OPTICALLY PUMPED GAS-MIXTURE FIR LASERS

Beijing DIANZI XUEBAO [ACTA ELECTRONICA SINICA] in Chinese Vol 13, No 1,
Jan 85 pp 117-119

[Article by Pan Chengzhi [3382 2110 1807], Han Shaoping [7281 4801 1627],
Qin Yi [4440 3015], Hou Qiguo [0683 0366 0948] and Liu Xiuyun [0491 4423 0061],
Beijing Vacuum Electron Devices Research Institute]

[Text] Abstract: With D_2O-CH_3I , D_2O-CH_3F , CH_3I-CH_3F and $D_2O-CH_3I-CH_3F$ gas mixtures as the active media of FIR lasers, individual FIR laser lines emitted from component gases can be obtained from the same laser simply by tuning the pumping lines of a TEA- CO_2 laser. The gas-mixture FIR laser is considered as a new and feasible scheme for producing multiwavelength output in FIR band from the same FIR laser.

This paper describes the results of the application of the scheme reported in references (1) and (2) of a far infrared (FIR) laser using gas mixtures as lasing materials. Binary and tertiary gaseous mixtures of D_2O-CH_3I , D_2O-CH_3F , CH_3I-CH_3F and $D_2O-CH_2I-CH_3F$ were studied.

Experimental Apparatus

The experimental apparatus employed in this study had been described in detail in reference (3). However, it should be noted that the FIR tube used is 2 m long with an inner diameter of 39 mm. In addition, the partial pressures of the component gases and the total pressure of the $CO_2:N_2:He$ mixture circulating in the TEA- CO_2 laser had been so adjusted that the pulse bandwidth of the output beam was ranging from 100 ns to $3\mu s$ ⁽⁴⁾. When the experimental apparatus was operating with the narrow pulse band (100 ns), a maximum beam power of 60 MW was produced; when the wide pulse band ($3\mu s$) was operating, the beam power was 3 MW.

In our experiment, the partial pressures of the component gases of the mixtures studied were determined by the optimal pressure of the gas when it lases by itself⁽³⁾ and the beam outputs at various wavelengths; in order to ensure an even energy distribution of individual spectral lines, the optimal pressure of the gas producing the weakest beam at that particular wavelength was chosen as the partial pressure of that gas in the mixture; based on this, the partial pressures of the second and third gas were then selected accordingly.

Experimental Results

The lasers of D_2O , CH_3I and CH_3F were produced by pumping with CO_2 lasers of 9P32, 9R12, 9R22, 10P18 and 9P20. The wavelengths obtained for D_2O emitted beams were $66\ \mu m$, $114\ \mu m$ and $385\ \mu m$; they were $447\ \mu m$ for CH_3I and $496\ \mu m$ for CH_3F .

Since the power output of FIR laser produced by pumping with wideband pulses is, generally, larger than that produced by pumping with narrow band pulses⁽⁵⁾, we shall concentrate the discussion on the results obtained by pumping with a wideband pulse ($3\ \mu s$).

Figures 1(a), (b), (c) and (d) depict the proportional relationship of the relative beam output of the 4 aforementioned gas mixtures at different wavelengths and the varying total pressures. In figure 1(a), the partial pressure of CH_3I was fixed at 2.4 torr; D_2O was then gradually introduced. The figure shows that the beam of CH_3I at $447\ \mu m$ over a wide-range of the increasing total pressure. The beams of D_2O lasing at $66\ \mu m$ and $385\ \mu m$ all reached peak values within the pressure range investigated. The optimal partial pressures corresponding to maximal beam outputs were slightly higher than the respective optimal pressures when the individual gas was lasing by itself. When the D_2O partial pressure fell between 2.3 to 3.0 torr, a 20-percent decrease in the beam output of CH_3I was observed.

As shown in Figure 1(b), the partial pressure of CH_3F was kept at 4.0 torr, the partial pressure of D_2O was then increased gradually. The CH_3F lasing beam at $496\ \mu m$ emitted over a wide range of the increasing total pressure and at the same time, the 3 D_2O beams reached their respective power maxima. There was a 30-percent decrease in the output of the $496\ \mu m$ beam when the partial pressure of D_2O was between 2.3 to 3.0 torr.

In Figure 1(c), a constant partial pressure for CH_3F was first stabilized at 3.2 torr, then, the partial pressure of CH_3I was raised slowly. The power output of the CH_3F beam at $496\ \mu m$ increased with the growing total pressure of the system, while the output of CH_3I beam at $447\ \mu m$ climbed to a maximum, then came down.

In Figure 1(d), 4.8 torr of CH_3I and 3.2 torr of CH_3F were introduced first; the D_2O pressure was then raised gradually. With more and more D_2O were added, the outputs at $496\ \mu m$ and $447\ \mu m$ also climbed slightly; in the meantime, the respective outputs at $66\ \mu m$, $114\ \mu m$ and $496\ \mu m$ took gradual increases, peaked then sank down.

The experimental results clearly indicated that in the gaseous mixtures employed in this study, there was neither chemical reaction nor vibrational energy transfer taking place between any two component gases which still exhibited their respective characteristic absorption and emission properties, absorbing pumping energies of specified wavelengths and emitting their distinct FIR beams. Only slight deviations in optimal pressures corresponding to maximal energy outputs in gaseous mixtures compared to individual optimal pressures were observed as a result of interacting gas molecular dynamics.

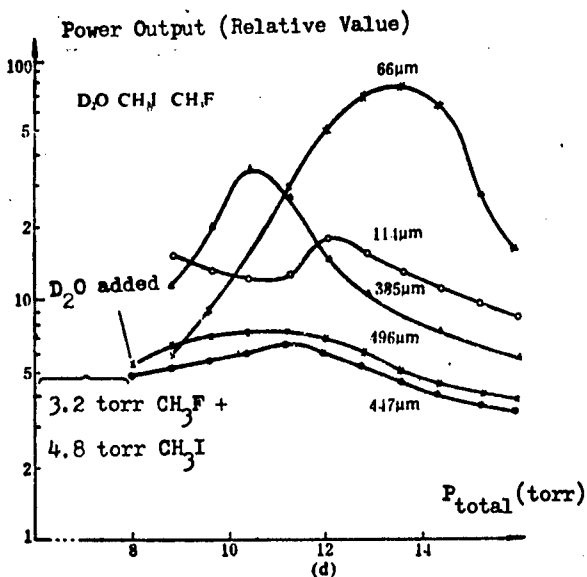
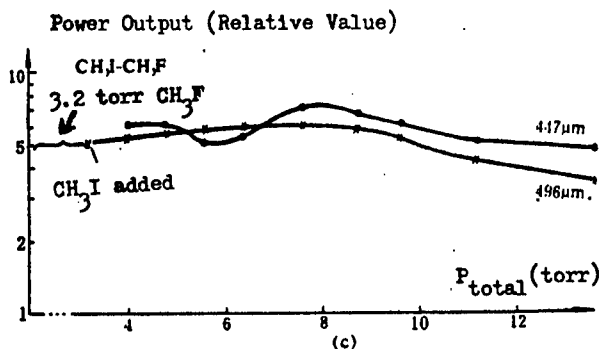
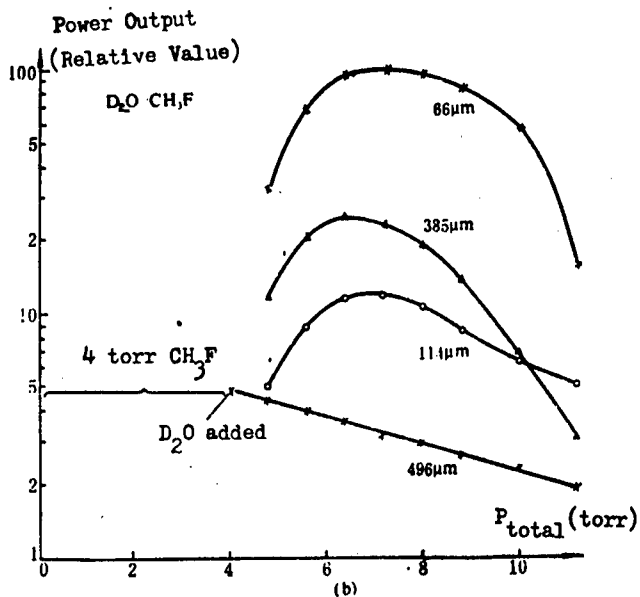
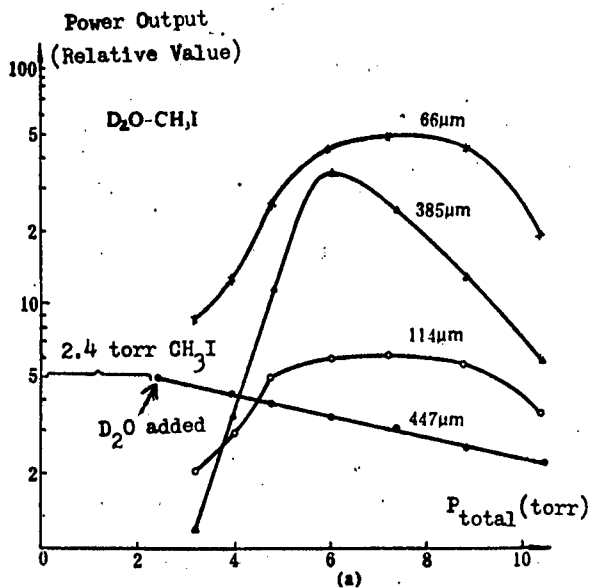

Fig. 1 The relative energy output of FIR at different wavelengths against the increase in total pressure of the gaseous mixture. Pumping energy at bandwidth of $3\mu\text{s}$: $E(9P32) = 4.4\text{J}$ (for beam of $66\mu\text{m}$), $E(9R12) = 4.9\text{J}$ (for beam of $114\mu\text{m}$), $E(9R22) = 6.0\text{J}$ (for beam of $385\mu\text{m}$), $E(10P18) = 6.1\text{J}$ (for beam of $447\mu\text{m}$) and $E(9P20) = 6.0\text{J}$ (for beam of $496\mu\text{m}$).

Conclusion

This study was a successful demonstration: it utilized mixtures of the FIR lasing materials $\text{D}_2\text{O}-\text{CH}_3\text{I}$, $\text{D}_2\text{O}-\text{CH}_3\text{F}$, $\text{CH}_3\text{I}-\text{CH}_3\text{F}$ and $\text{D}_2\text{O}-\text{CH}_3\text{I}-\text{CH}_3\text{F}$ which are chemically inert to each other and which also allow no vibrational energy transfer, as the active media for pulse-pumped FIR lasers. Under properly

adjusted partial pressures of the component gases, with finely tuned pumping lines of a TEA-CO₂ laser, each gas in the mixture independently lases an FIR beam yielding an energy output matching that of the laser of the pure gas. Therefore, we believe that the gas-mixture FIR laser presents a new, feasible scheme for a laser system that is capable of producing multiwavelength FIR beams.

References

- (1) Pan Chengzhi et al, JIGUANG [LASER JOURNAL], Vol 9 No 5, p 61 (1982).
- (2) Pan Chengzhi et al, JIGUANG [LASER JOURNAL], Vol 9 No 11, p 703 (1982).
- (3) Qin Yi et al, JIGUANG YU HONGWAI [LASERS AND THE INFRA RED], No 3, p 73 (1984).
- (4) Pan Chengzhi et al, DIANZI XUEBAO [ACTA ELECTRONICA SINICA], Vol 12 No 5, pp 93-95 (1984).
- (5) Han Shaoping et al, JIGUANG [LASER JOURNAL] to be published.

12817

CSO: 4008/241

LIFE SCIENCES

MILITARY SYMPOSIUM ON MICRORECONSTRUCTIVE SURGERY SUMMARIZED

Beijing JIEFANGJUN YIXUE ZAZHI [MEDICAL JOURNAL OF CHINESE PEOPLE'S LIBERATION ARMY] in Chinese No 6, 20 Dec 84 pp 467-469

[Article by Zhu Shengxiu [2612 4141 0208] and Wang Huimin [3769 1920 2404] of People's Liberation Army General Hospital: "First Military Symposium on Microreconstructive Surgery; A Summary of Papers and a Discussion of Related Questions"]

[Text] Microreconstructive surgery is a new technique developed in the last 20 years that is now used in all surgical fields. As early as the early 1960's Chinese surgical workers launched scientific research and clinical work in microsurgery. At the beginning of the 1970's some hospitals in every major city launched relatively extensive work in this area. The Ninth and Tenth National Symposia on Surgery, convened in 1978 and 1983, emphasized summarization and discussion of work in microsurgery, greatly spurring further development in Chinese microsurgery.

In the wake of progress both at home and abroad, the military's work in microreconstructive surgery has also achieved relatively good success. In 1979 and 1980, Shenyang Military Region General Hospital designed the forearm flap and the upper arm flap. The forearm flap won international acclaim and is called the "Chinese flap" in literature abroad. In 1979, after articles were published on the musculus extensor digitorum brevis pedis flap designed by People's Liberation Army General Hospital, and on the microsurgical operation they performed to depress the peripheral nerve to treat neural causalgia, medical centers and libraries from many nations wrote to ask for data. In 1980 the 2d Army Medical College's 1st Teaching Hospital obtained very good results with an anastomotic vascular and neural graft of the second metatarsophalangeal joint to repair an injury to a metacarpophalangeal joint. In 1981 the 2d Army Medical College's 2d Teaching Hospital creatively designed a penile renewal operation using the forearm flap and received favorable comments from specialists at home and abroad. In 1982 the scapular flap designed by Hospital 175 also added a therapeutic technique to microreconstructive surgery. The Chinese military also has made new achievements in the replantation of severed limbs. Hospital 401 and Hospital 89 have a greater than 95 percent success rate in the replantation of severed limbs on juveniles. They have also achieved good results with creative replantation on the stumps of severed hands and in hand reconstruction. In the wake of clinical developments in micro-reconstructive surgery, the department of anatomy at the 1st Military Medical

College has systematically conducted research on microdissection. They have made useful accomplishments in microdissection studies of lymph in the extremities and in research on dermal circulation through intramuscular septum blood vessels in the extremities. Some of these accomplishments were pioneered in China and some in other nations. Some have attained advanced domestic levels, illustrating that microreconstructive surgical operations are at a certain advanced level in China's armed forces.

In order to summarize all military accomplishments in microreconstructive surgery, the 1st Military Symposium on Microreconstructive Surgery was held from 26-31 August 1984. There were 84 delegates to the symposium, including orthopedists, burn specialists, plastic surgeons, jaw and face specialists, urologists, general surgeons and representatives from all anatomical fields.

Of the total of 262 papers received at the symposium, 102 were presented at the plenary session. From the units contributing it is apparent that military work in microreconstructive surgery extends to military hospitals in all major military regions. Preliminary statistics indicate there is a total of 6,092 people conducting microreconstructive surgery in the military. From the content of the symposium it is apparent that the numerous surgical workers throughout the armed forces have expanded microreconstructive surgery for application in all surgical fields. Particularly in the treatment of combat wounds there have been new breakthroughs due to the adoption of microsurgical techniques, allowing the repair of previously untreatable wounds. From the quality of contributions it is apparent that there have been new advances by comparison with the microreconstructive surgery discussed at the 2d Military Symposium on Osteology and the 10th National Surgical Symposium, both held in 1983.

I. Basic Research

There is a group of experimental research that verifies that the unobstructed proportion of blood vessels with overlapping fold sutures is lower in those vessels of 2 mm caliber and above than for somewhat smaller blood vessels. This research indicated that we should pay clinical attention to overlapping fold suturing on blood vessels. There is another group of experiments that observes that in a vascular anastomosis of 1mm or smaller in outside diameter, the unobstructed proportion of the artery is lower with decollement of the tunica externa than without it. This illustrates that less decollement of the vascular tunica externa is best when there is vascular anastomosis.

With respect to the source of dermal blood supply, some people have pointed out that in addition to direct dermal arteries and penetrating musculocutaneous arterial branches there are also tiny dermal branches and indirect dermal arteries. However, there are also some people who believe that the source of dermal blood supply is divided between direct dermal arteries and musculocutaneous arteries, that each of these is divided into the deep and the superficial and that there is a difference in thickness between the two. There are people who, having conducted microdissection of blood vessels to study the blood supply to the musculus tensor fasciae latae flap, believe that the blood supply from the fringe branches of the musculocutaneous artery to the musculocutaneous flap is clinically significant.

Research has also been conducted into the range of dermal blood supply. Perfusion was observed in some commonly used flaps on 6 cadavers that had been dead of trauma less than 8 hours. The range of dermal staining acts as a reference for the clinical supply of excised flaps. Some workers have concluded from anatomical research and clinical observation that the perfusion range of an artery supplying an axial flap is generally greater than its distribution range. This is related to the anastomotic forms between neighboring arteries and the caliber of anastomotic blood vessels. Consequently, when excising a flap, the various conditions above should be the basis for the excision.

One group conducted observations of the foramen nutricium of the scapular margo axillaris in 110 cases and provided an anatomical basis for an anastomotic vascular graft of the scapular margo axillaris. They successfully conducted an anastomotic vascular graft of the scapular margo axillaris in September 1982. They also used autopsies to study vascular humeral periosteal pedicle grafts and provide a periosteal supply region for clinical use. Through experimental observation of animals, they also verified that after osteological excision of the periosteum the circulatory function in bone from the supplying region is not affected. This is a significant idea for research on fascial flaps, but more thorough studies are still needed.

Some units have begun to conduct differential experimental research on peripheral nerve motor and sensory tracts, but up to now reports have appeared domestically. It would be very valuable if they were able to arrive as early as possible at some clinically applicable research results. Some units have achieved initial results in studies of end-place neuragenesis. There are also reports that isolated anatomical observation of natural splitting in the sciatic nerve is of some reference value in clinical operations, and that research on the anatomical association between the spermatic cord vein and the inferior epigastric vein provides a basis for treatment of spermophlebectasia.

Basic research in microreconstructive surgery has attracted the serious attention of many units. It is apparent from the content of papers presented at this symposium that research conducted today is inseparably linked to clinical needs or to the resolution of certain clinical problems. From now on we must launch intense theoretical and developmental research to promote further developments in microreconstructive surgery.

II. Anastomotic Vascular Tissue Grafting

Several new operation designs were reported at the symposium. For example, there was a design for the lateral foot flap using the lateral artery of the heel as the pedicle. Anatomical observations were conducted on cadavers and the procedure was applied on six clinical cases, with satisfactory results. There was a design for the medial femoral flap, using the major medial dermal artery of the thigh as the pedicle, that has been performed successfully in five operations. There were also reports of six successful cases of femoral anterolateral flap grafts using the arteria circumflexa femoris lateralis as the pedicle. There was experimental research and clinical application introducing anastomotic vascular fascial flaps to graft encysted bone masses, for which the

authors have reported two cases of clinical application. There are problems remaining with this method that require further research in order to explore its laboratory basis for blood supply. There were two reports of clinically successful anastomotic vascular peroneal and iliac osteoepiphysis grafts such as have not yet been introduced in this country. There were also reports of successful unilateral ovarian autografts. Some units reported research on new periosteal supply regions providing new means of handling nonsuccessive bone treatments.

There were also many reports at the symposium on new applications for old methods or on improvements to the original bases. For example, there were two cases of satisfactory results using microsurgical techniques in secondary operations to treat congenital tibial pseudoarthrosis in adults. There were 17 cases of the use of forearm flaps as free grafts to repair lingual defects, with only one failure. It has been concluded that repair and reconstruction of all kinds of lingual defects and deformities is best accomplished with the forearm flap. There was also one case report of an anastomotic vascular and neural graft of the musculus extensor digitorum brevis pedis flap to repair complex firearm damages to the face and jaw, and this has been quite satisfactory in rebuilding contours and intramuscular functions. Some authors successfully introduced partial great toe grafts to repair some six cases of thumb defects.

III. Replantation Surgery

Previous military experience in aspects of limb and finger replantation has been summarized and reported at some length. At this symposium some units summarized 55 cases that have been handled in the past 5 years, in which 61 fingers that had been severed close to the joints were replanted with a 96.7 percent digit survival rate. They also reported one case in which 10 severed fingers were replanted and 9 of them survived intact. One report was made on the necessary use of microsurgical techniques to conduct a successful transectional pancreatic replantation, something which has not yet been introduced in this country.

IV. The Applications of Microreconstructive Surgery

There has been some additional new progress in military microreconstructive surgery. Above all, there were numerous papers presented on the use of microsurgical techniques to conduct repairs in traumatological cases, wherein the tissue graft success rate has reached more than 90 percent. Among these, more than 20 of the papers discussed the use of microreconstructive surgical techniques in the treatment of combat wounds. For example, our therapeutic experiences were presented on the use of microreconstructive surgical techniques to treat 45 cases of firearm injuries to arteries in the extremities. These reports illustrate that microreconstructive surgery plays a very important role in improving the level of treatment for combat wounds, and that work to expand microreconstructive surgery is of immediate significance for combat readiness.

A great deal of information was also introduced at this symposium on the use of microreconstructive surgery in maxillary and facial restoration. Some units used

free flap reconstruction on tissue defects immediately after 16 buccal carcinectomies, and they concluded that the advantages of this method far outnumber those of traditional methods. One group successfully used microreconstructive surgery to treat 7 cases of maxillary and facial tissue defects, and they concluded that the various kinds of tissue grafts in microreconstructive surgery have many uses, achieve good results and produce nearly normal external appearances in maxillary and facial reconstruction. For example, many units have used microreconstructive surgery on the defects of facial hemiatrophy with satisfactory results. Some units have achieved success using anastomotic vascular rib grafts to repair three cases of firearm injury to the mandible. There were previous reports of the use of this method in China in which most cases resulted in failure, and as a result some students lost confidence in the method and adopted other means. However, this report of success provides experience in this kind of operation.

There were 10 cases summaries of therapeutic experiences with satisfactory results in the use of microreconstructive surgery to repair tissue defects subsequent to excision of tumors in the extremities. There were three cases, all successful, of the use of microreconstructive surgery to repair urethral fistulae, and this method worked better than traditional methods. Three cases were reported in which deep femoral lymphatic, phlebostic anastomosis was used to treat chyluria, with satisfactory short-term results. Some units reported on 6 cases, all successful, where the crust was removed early from deep burns to joint areas and reconstruction was conducted with anastomotic vascular flap grafts. There have also been uses of microsurgical techniques to suture muscle tendons, and this has improved the therapeutic results of muscle tendon grafts and suturing operations.

In short, after current microreconstructive surgery is applied to the various surgical fields it not only changes some traditional operating techniques but also improves curative results.

In order to further expand and improve the theoretical level of microreconstructive surgery, the following problems were discussed at the symposium:

1. Microreconstructive surgery is intimately associated with and can improve the level of combat injury treatment. It is hoped that the conditions will arise for units to conduct study courses in all kinds of microreconstructive surgery or for them to establish special sickrooms for microreconstructive surgery and arrange for microreconstructive surgery to be included in teaching materials.
2. We must organize all military forces involved in microreconstructive surgery and act in concert to decide on research objectives, share the work, cooperate together, fix dates for scientific conferences and spur on military theoretical research and techniques in microreconstructive surgery.
3. We must strengthen basic theoretical research. It is apparent from this conference that some Chinese military units are already involved in basic theoretical research work in microreconstructive surgery because it plays an extremely important role in promoting the development of microreconstructive surgery.

4. We must have a good grasp of the operative indications for microreconstructive surgery. Microsurgical techniques have opened a new path in reconstructive surgery that enables us to shorten the course of treatment, reduce the frequency of reconstructive operations and have good reconstructive results. However, the techniques are very difficult and there is a certain failure rate, so we must have a good grasp of indications. In general, when we can use other, simpler methods to achieve similar results we need not employ microreconstructive surgery. At this symposium there were some articles worth future notice in which operative indications were unsuitable. We have selected some unit reports on vascular pedicle transfer flaps, muscle flaps and skeletal transpositions that all merit expanded use.

12510

CSO: 4008/205

ENVIRONMENTAL QUALITY

GEARING DEVELOPMENT OF ENVIRONMENTAL SCIENCE TO ECONOMIC CONSTRUCTION

Beijing HUANJING KEXUE [JOURNAL OF ENVIRONMENTAL SCIENCE] in Chinese No 4,
30 Aug 84 pp 1-3

[Article by Editorial Department: "Develop Environmental Science by Gearing it to Economic Construction--On the 35th Anniversary of the Establishment of the PRC"]

[Text] In the same manner as the problems of population and natural resources have now become major socioeconomic problems of common concern to all peoples of the world, the problem of the environment has also become one of the important research topics in science and technology.

The natural environment is nurturing mankind, and mankind's activities are changing the natural environment. Due to the exceedingly rapid advances of science and technology in modern times, mankind has acquired the ability to change the environment on an unprecedented scale, thereby, on the one hand, creating a more beautiful and more agreeable material environment, but, on the other hand, also assaulting and bearing down on the environment. It is against this historical background that environmental science has come into being; it arose as the product of a certain phase in the progress of human civilization.

In China, work for the protection of the environment has a history of more than 10 years, during which time a certain amount of experience has been accumulated, constituting a foundation for our future work in this respect. However, the task that is still before us will require further and extremely arduous efforts and a long-term untiring endeavor. On the occasion of the 35th anniversary of the establishment of the PRC, this journal is preparing a summary review of the main environmental research done in China, based on the manuscripts and data received by us over the years, and will also add a few, even if superficial, ideas on the developmental trends of environmental science and on the question of its service to China's economic construction.

1. Remarkable Successes Achieved in China's Environmental Science Research

With the growing need for environmental protection in China, the past 10-odd years of China's environmental science research have been 10-odd years of pioneering work and 10-odd years of progress through a continuous process of

exploring and probing. Since 1972, China has launched systematic research in environmental protection under the solicitude and guidance of Premier Zhou Enlai. Starting out from the current conditions of environmental pollution, integrating macro- and microstructural aspects and employing new technologies and methods, this research, on the one hand, carried out investigations, analyses, assessments and forecasts of the macrostructural conditions of pollution, and; on the other hand, probed deeply into series of microstructural aspects of existing pollutants, the laws governing their movements and their biological effects, seeking out methods and ways to control and improve environmental quality. Because environmental protection work relates to a broad field of concerns and is of a highly diversified nature, China organized scientific and technical personnel from many relevant disciplines, such as earth science, biology, chemistry, physics, medicine, engineering, agriculture, forestry and from the new technologies, for joint cooperation. Large scale research work was launched to investigate and monitor environmental pollution and to carry out comprehensive research in regional environments, research the control of individual sources of pollution and their comprehensive prevention, the ecology of pollution, distribution, movement, transformation and the remaining residual of pollutants in the environment. It must be pointed out, though, that a foundation had been created earlier in indoor research on the relationship between environment and ecology, carried out in the various related disciplines, such as botany, zoology, forestry, marine biology, oceanography and geology. Furthermore, through repeated large-scale and comprehensive scientific investigations and observations, fundamental data of almost every type of climate, soil, vegetation, desert, prairie, ocean current, etc. had become well known, and there had been a substantial foundation of research regarding the ecology of forests, prairies, cultivated fields, arid and semiarid regions.

In the wake of progressing research, corresponding development took place in the various branch disciplines of environmental science, where depth and spread of research increased rapidly in such fields as environmental chemistry, biology, earth science, medicine, acoustics, engineering, economics, management science and environmental jurisprudence. Many experienced scientists took part in the guidance and actual work of this research. They also organized and nurtured a fledgling contingent of science and technology research personnel. In the Chinese Academy of Sciences, for instance, there are by now 41 research institutes (laboratories, groups) with more than 1,200 specialists engaged in environmental work. In the time of a little over 10 years, they successfully completed more than 500 research projects. In the central administration and its subsidiary units, the departments concerned have set up 79 scientific environmental research and monitoring organs. Universities, colleges and the Chinese Academy of Social Sciences have established 27 relevant research institutes (laboratories, groups), and most provinces, municipalities and autonomous regions have also established environmental research institutes or monitoring stations. The entire body of specialists engaged in research in the environmental science throughout the country number more than 7,000. They have completed more than 2,100 research projects on the basic theories and applied technologies of environmental standards, some of them having won national awards.

Environmental monitoring work has also progressed rapidly. Various environmental protection departments have established more than 650 monitoring stations. Fifteen cities have initially set up monitoring stations for the automatic monitoring of the atmosphere. Beijing Municipality has set up a continuous automatic monitoring system, consisting of a central station and 9 substations. Every year, regular atmospheric monitoring data and regular water quality monitoring data are collected in the millions throughout the country.

2. The Development of Environmental Science

The main target of environmental science research is the relationship between human activities and the environment, particularly the effects on the world of nature and on human society of the environmental pollution and destruction created in the course of the rapid development of our contemporary industrial and agricultural production. The research also deals with countermeasures to eliminate these effects and seeks to find a path that would provide an environment of greater benefit and beauty for mankind.

In the 1950's, when incidents of large-scale pollution had repeatedly occurred in certain industrially developed countries, many scientists from such fields as biology, chemistry, medicine, geography, physics, engineering and from the social sciences jointly instituted investigations and cooperative studies of preventive measures. They began by studying the problems of the environment on the basis of theories and methods applicable to their own disciplines, which led many disciplines of the natural sciences to take up the study of the environmental effects created by human activities as important research topics of their fields. Later, cooperation between various disciplines brought about mutual permeation and the formation of a new discipline that was comprehensive and transdisciplinary in nature. The environment is an extremely complex organic entity, and human activities, for instance, population growth, exploitation of natural and energy resources and economic developments, all, directly or indirectly, affect the environment. Research and efforts to resolve environmental problems must, therefore, take the overall situation in its entirety into consideration and effect transdepartmental and transdisciplinary cooperation. Within this complex system, environmental science in fact mainly bases on the fundamental theories of ecology, geochemistry and economics. It makes full use of the knowledge of various relevant disciplines, such as the natural sciences, engineering technologies and the social sciences, and carries out systematic and comprehensive studies of the environmental changes wrought by human activities.

Since environmental science explores on a worldwide scale the mutual interactions, and the developmental laws of such, as between mankind and the environment, and studies the coordinative relationship between human production and consumption and the natural ecology, then human production and consumption should maintain a dynamic equilibrium between input into the environment and extractions from it of material substances and energies. This equilibrium demands that the discharge of waste material not exceed the self-purification capability of the environment, to avoid pollution, and that

extraction of resources from the environment be for rational developmental purposes, to avoid an imbalance in the ecology and an exhaustion of resources. Changes in the environment are brought about by physical, chemical, biological and social factors and their interactions. Destructions in the natural ecosystem, for instance, destruction of vegetation, soil erosion, soil deterioration, progressive desert formation, climatic abnormalities, etc., often lead to natural calamities which endanger human existence and development. It is therefore a major topic of environmental science research to promote a beneficial circulation in the ecology. Environmental pollution is equally an important part of environmental science research, studying the action and mechanism of movement, transformation and retention of pollutants in the ecosystem and the various effects on the biology and human health, also gaining knowledge of their dangers. The research, furthermore, studies various measures of engineering technology for the prevention of environmental pollution and the utilization of various social measures of control, such as legislative, administrative, economic and educational means.

Pollution control in the industrially developed countries has passed through several stages: In the 1950's, it was mainly efforts to control the sources of pollution; in the 1960's, efforts shifted toward comprehensive regional pollution control; in the 1970's, the emphasis was on regional planning, rational distribution, exploring ecological zoning and resource management, with prior emphasis on prevention. Many countries have instituted systems of environmental evaluations. Practice has confirmed that it requires the comprehensive employment of a variety of engineering and management measures to resolve environmental problems, and that using the methods of system analyses and system engineering, on the level of a regional environment in its entirety, in seeking the most effective program, is the direction of comprehensive pollution control.

Following mankind's progress in the protection of the environment, environmental science began to shape its own theories and methods. For instance, in the question of the contemporary ecological imbalance, if one were to merely study the natural evolution of the ecosystem, it would be quite impossible to fully explain the developmental laws of its evolution. It is only by studying the ecosystem together with the socioeconomic system of mankind as a whole, that one can thoroughly reveal the essence in the problem of ecological balance and clarify its developmental laws, and it is only then that mankind will be able to use these laws in a purposeful control of evolution in the ecosystem and render it more and more beneficial for mankind's existence and development. Through many years of research, a theory was evolved on the mutual relationship between the ecosystem and the socioeconomic system, called by many ecologists the "composite socio-economic-nature-ecosystem." At the same time, environmental science created some of its own research methods. For instance, in evaluating environmental quality, the study of the historical conditions of the environment was integrated with the study of its current conditions, the study of microstructural aspects was integrated with the study of kinetic aspects. Furthermore, the theories of mathematical statistics were adduced and mathematical models and evaluating procedures were set up, forming a set of research methods that basically can

reveal, comprehensively and accurately, the quality of the environment and the laws governing its changes. This indicates that this new discipline, the environmental science, is truly maturing with each passing day.

3. The Strategic Aim of China's Environmental Protection and the Tasks of Environmental Science Research

Environmental science research must be geared to the needs of China's economic construction and to solving China's environmental problems. The party and the state attach a high degree of importance to the work of environmental protection and demand that it be raised to a new and higher level and that a new overall situation be initiated in this work.

The Second All-China Environmental Protection Conference pointed out: "Our striving objective to be achieved by the end of this century is that energetic efforts will have basically solved the problem of environmental pollution throughout the country, that beneficial circulation will be basically restored to the natural ecology, that a clean, beautiful and quiet environment will prevail in the production and living conditions in town and countryside, and that the environmental conditions throughout the country can basically be rendered consonant with the development of the national economy and the rise in the level of the people's material and cultural livelihood."

The environmental problem is a new problem met with in China's economic construction; it is also a major issue that touches on the interests of the state and of the people as a whole. The environmental problems now existing in China are, generally speaking, the very conspicuous environmental pollution problems in the cities and in the industrial and mining areas, as well as the problem of the destruction of the natural ecology, a problem that primarily exists in the villages. To solve these problems and to achieve our strategic environmental objectives, it is without any doubt necessary to bring the precursory functions of environmental science and technology fully into play and rely on scientific and technological progress. However, the current level of China's environmental science and technology, despite marked improvements in recent years, is still far from sufficient to be able to solve our problems; it is particularly weak in the study of applied technologies and environmental controls. The task of further research in environmental science and technology is, therefore, an extremely arduous and important one.

As China's environmental protection work is guided by a series of principles, such as giving priority to prevention, integrating prevention with control, establishing comprehensive controls and comprehensive utilization of resources, strengthening environmental management and promoting controls through proper management, we must exert great efforts in strengthening the applied research in environmental science and technology. Speaking of the larger aspects involved, there are the regional environmental protection, city environmental protection, prevention of industrial pollution, the environmental influence of new large- and medium-sized engineering projects, technological countermeasures protecting the environment of energy sources, protection of water resources, protection of the agricultural environment,

protection of the natural ecology, etc. All these present a series of important environmental topics that urgently await immediate solutions, or topics that may come up in the future. They require greatest efforts on the part of our workers in the environmental science, to launch research in these directions. Taking protection of the city environment as example, a large number of environmental topics present themselves in the city ecosystem within city planning, in the control of the atmosphere and of water quality, in noise and solid waste pollution, in the rational distribution of industry in relation to the control of new sources of pollution when using advanced applied technologies in the restructuring of existing industries, in the pollution by industries in villages and townships in relation to city and township construction plans. All these topics demand that we conscientiously study them and provide solutions on a scientific and technological basis.

Being a developing socialist country, there are hundreds of undertakings in China that await development, while China's financial strength is limited. A large number of environmental problems have accumulated in China over the years, problems that require not only modern science and technology, but also expenditure of huge amounts of financial and material strength for their solution. It is therefore necessary for us to engage in long-term sustained and untiring efforts. In our work of environmental science research we must emphasize that the starting point must be China's actual conditions. We must as quickly as possible turn research results into forces for the solution of actual problems, as we strive to attain a unison of environmental, social and economic effectiveness. At the same time, we must give close attention to the direction of the new technological revolution in the world. The steep rise in scientific and technological developments must provide a new upsurge for our social productive forces and must also spur on the development of environmental science and technology. We must accumulate a certain scientific reservoir, give serious attention to basic theoretical research and promote the development of this discipline.

As a specialized scholarly periodical, this journal will make every effort to contribute to the exchange of research results and toward raising the level of scientific research in the field of environmental science and technology.

9808

CSO: 4008/13

AUTHOR: DAI Yaosen [2071 5069 2773]

ORG: None

TITLE: "The Probability Convergence Theorem of Time-Varing Channel Sequential Detection and the Error Increment Caused by Detection Cut-off"

SOURCE: Hangzhou HANGZHOU DAXUE XUEBAO (ZIRAN KEXUE BAN) [JOURNAL OF HANGZHOU UNIVERSITY (NATURAL SCIENCES EDITION)] in Chinese Vol 12 No 1, Jan 85 pp 27-32

ABSTRACT: This paper first gives a precise description and the proof of double stationary random time-varing channel maximum likelihood sequential detection theorem by using the central limit theorem of stationary K-dependent random variable sequence. Then, the quantitative computation of probability convergence rate of maximum likelihood sequential detection is executed. Finally, the error increment problem of sequential detection cut-off is discussed and the relations between the multipath spread and sequential detection technique are explained. The main results obtained are expressed as several theorems and corollaries.

Biochemistry

AUTHORS: ZHANG Rongliang [6774 2837 2733]
CAO Anbang [2580 1344 6721]
LESKO, S. A.

ORG: ZHENG of Biochemistry Faculty Research Section, Lanzhou University;
CAO and LESKO of Department of Biophysics, College of Hygiene, Johns
Hopkins University, Baltimore

TITLE: "Role of Superoxide Dismutase in Tumor Cell Toxicity"

SOURCE: Beijing SHENGWU HUAXUE YU SHENGWU WULI JINZHAN [BIOCHEMISTRY AND
BIOPHYSICS] in Chinese No 6, Dec 84 pp 34-35

ABSTRACT: The depressant diethyl dithiosodium carbamate (DDC) of superoxide dismutase (SOD) can potentiate the efficacy of anticancer drugs and enhance the radiosensitivity of cells; therefore, DDC is a promising reagent for integrated chemotherapy and radioation therapy of carcinomas. The authors found that DDC lowers the SOD activity of cancer cells, thus lowering their survival rate. The reagent can also inhibit cancer cell multiplication, by lengthening the multiplication period. Since SOD activity is closely related to variation in DNA synthesis, SOD activity plays a major role in whether or not cancer cells can survive when poisoned with DDC. The paper emphasizes the study of the effect of DDC on the SOD activity of cancer cells, as well as the function of SOD in cell toxicity. The authors are presently active in lipid coating of SOD for entrance into cells, thereby observing the function of SOD in cancer cells.

Three tables show the effect of DDC on the total SOD and CAT content in cancer cells, the role played by exogenous enzymes in cell survival and SOD activity in cells and cultural solutions after the addition of SOD. One figure shows the effect of different DDC concentrations on the synthesis of Mn-SOD DNA in cancer cells, and the cell colony formation rate.

10424
CSO: 4009/214

Biochemistry

AUTHORS: FAN Peichang [5400 1014 2490]
SHAN Zhifang [0830 1807 5364]
GUO Zhiqin [6753 1807 3830]

ORG: All of Department of Biology, Huadong Normal University, Shanghai

TITLE: "Electrochemical Method for Determination of Enzymic Activity and Its Causal Factors"

SOURCE: Beijing SHENGWU HUAXUE YU SHENGWU WULI JINZHAN [BIOCHEMISTRY AND BIOPHYSICS] in Chinese No 6, Dec 84 pp 59-61

ABSTRACT: For the rapid, accurate, automatic and continuous measurement of the activity of acetyl cholinesterase (AChE) and other enzymes in the membrane of red blood cells, the authors designed and assembled an electrochemical measuring apparatus for enzyme activity. The paper reports the experimental results of a determination of the activity of pure cholinesterase (ChE) by using the apparatus. Four figures show a schematic diagram of the wiring and assembly of the electrochemical apparatus, a voltage versus time curve of the ChE hydrolysis of AcSChI, the effect on ChE reaction by ChE concentration, AcSChI concentration, reaction solution pH, and reaction tank temperature, and a photo showing the exterior of electrochemical apparatus.

The paper was received for publication on 19 September 1983.

10424
CSO: 4009/214

Biochemistry

AUTHOR: QI Zuhe [3823 4371 0735]
ORG: Biochemistry Laboratory, Fundamental Research Institute, Chinese Academy of Medical Sciences
TITLE: "Sequencing Nonspecific Degraded DNA Fragments With the Chain Termination Method"
SOURCE: Beijing SHENGWU HUAXUE YU SHENGWU WULI JINZHAN [BIOCHEMISTRY AND BIOPHYSICS] in Chinese No 6, Dec 84 pp 66-67

ABSTRACT: Among the methods of using chain termination in determining DNA sequencing is the use of an intracellular enzyme repressor to degrade the DNA under determination, before using bacteriophage for M_{13} DNA recombination and cloning. By using a single DNA chain as the template, the determination of sequencing can proceed. Seeking some nonspecific degraded material to replace the intracellular enzyme can lead to certain savings. In particular, after the advent of the carrier M_{13} mp series of multienzyme scission sites, DNA recombination has been further facilitated. The paper describes scission by using the enzymatic method and the ultrasonic method in obtaining flush-terminal recombination fragments that are suitable for the M_{13} mp₈ carrier.

In the nonspecific method, DNA can be cut at random. Generally, about 300 bp is the suitable fragment size in DNA cloning. Thus, consumption of the intracellular enzyme can be economized, and it is advantageous in seeking for splicing sites. This is the method recommended by the author as appropriate to general laboratory conditions.

The DNA fragments are shown in I through V sequencing. The paper was received for publication on 19 August 1983.

10424
CSO: 4009/214

AUTHOR: LI Yongxi [2621 3057 1585]
ZHANG Yongfu [1728 3057 4395]
XIA Yuanfu [1115 0337 1788]

ORG: LI of the Research Institute of Petroleum Processing, Beijing;
ZHANG of the Institute of Shanghai Petrochemical Complex Works; XIA of the
Department of Physics, Nanjing University

TITLE: "Study of the Valence States and Behavior of Sn in Pt-Sn/ γ -Al₂O₃
Catalysts Prepared by Co-precipitation"

SOURCE: Beijing CUIHUA XUEBAO [JOURNAL OF CATALYSIS] in Chinese No 4, Dec 84
pp 311-319

TEXT OF ENGLISH ABSTRACT: The valence states of Sn in the Pt-Sn/ γ -Al₂O₃ reforming catalysts of different Sn contents were studied by Mössbauer spectroscopy and X-ray photoelectron spectroscopy (XPS) in various pretreatment stages. Mössbauer spectra of the catalysts showed the characteristic isomer shift for Sn⁴⁺, Sn⁰ and Sn²⁺ respectively, but the absorption of Sn⁴⁺ in each spectrum of Pt-Sn/ γ -Al₂O₃ catalysts prepared by co-precipitation was significantly larger than that of Sn⁰ and Sn²⁺. The results were consistent with those obtained from XPS experiments. In addition, it was found from XPS that the Sn_{3d_{5/2}} binding energies of catalyst samples were lower than those of standard tin chlorides, and the Cl_{2p} binding energies (198.4-198.6 eV) of catalyst samples were also lower than those (200.4 eV) of SnCl₂/ γ -Al₂O₃ and SnCl₄/ γ -Al₂O₃, but very close to that of HCl. Therefore, the chlorine in the catalyst samples seems to be in the form of HCl, which is adsorbed in the support of the catalysts. The Mössbauer parameters were obtained by computer fitting from the above results. It was shown that the distributions of tin compounds in the catalysts were almost the same after reduction, though the contents of tin were different (from 0.3 to 1.5 wt percent). The Sn in reduced catalysts presented mainly in the form of Sn⁴⁺ (SnAl₂O₅, SnO₂) and partially in Sn²⁺ (SnAl₂O₄, SnO) and Sn⁰. No tin chloride has been found. The Pt-Sn alloys appeared as the result of the action of Sn⁰ and Pt, with the atomic ratios of Sn/Pt in the alloys changing when tin content in the catalysts increased. The states of tin in the catalyst were fairly stable after calcination, reduction and reaction, and remained mainly in Sn⁴⁺. No significant changes in the amount of alloy were observed, however, and the contents of both SnAl₂O₅ and SnO₂ in the Sn⁴⁺ species were convertible. From calcination to reduction, the content of SnAl₂O₅ increased, whereas it decreased after reaction. The amount of SnAl₂O₅ after reaction was even less than that after calcination, however the amount of SnO₂ increased. Nevertheless, the states of tin in the catalyst prepared by the co-precipitation method were much more stable than those prepared by other methods. It is then suggested that there is an interaction between tin oxide and Al₂O₃ support in the catalyst, and this interaction seems to play an important role in reforming reaction as seen from the fact that the catalyst prepared by co-precipitation exhibits excellent catalytic performance.

AUTHOR: SHEN Pingsheng [3088 1627 3932]
LI Dadong [2621 1129 2639]
MIN Enze [7036 1869 3419]

ORG: All of the Research Institute of Petroleum Processing, Beijing

TITLE: "On the Relationship Between the Mechanical Strength of Catalyst Support Titania and Its Pore Structure"

SOURCE: Beijing CUIHUA XUEBAO [JOURNAL OF CATALYSIS] in Chinese No 4,
Dec 84 pp 320-325

TEXT OF ENGLISH ABSTRACT: The mechanical strength and the pore structure of titania support prepared from hydrolysis of titanium sulfate-ammonium hydroxide have been investigated by means of BET measurements, mercury porosimeter and scanning electronmicroscope. It was observed that the appearance and pore structure of titania support were strongly influenced by the pH value of the precipitate, for example, the total pore volume ($r \geq 50 \text{ \AA}$) of the support decreased from 0.92 ml/g to 0.15 ml/g and the radius distribution decreased from 50-80000 \AA to 50-1400 \AA as the pH value of the precipitate decreased from 6.7 to 2.9, and the mechanical strength of titania support increased rapidly from 37 kg/cm² to 710 kg/cm² as the total pore volume of the support decreased from 0.92 ml/g to 0.15 ml/g, especially as the pore volume, having a pore radius of more than 300 \AA decreased from 0.76 ml/g to 0.005 ml/g.

Quite different total pore volumes and pore size distributions were formed after heat treatment even as low as 30°C. The great changes of pore size distribution occurred in the range of 30-150°C, but there was little change of pore size distribution above 150°C. It was concluded that the pore structure of the support depends mainly upon the state of the wet precipitate before heat treatment.

A possible way of enhancing the mechanical strength of titania support is to promote the aggregation of the wet precipitate. To satisfy the good performance of the support, the suitable pH value of the precipitate should be around 5.0.

AUTHOR: TANG Shaoping [0781 1421 1627]
ZHU Angru [2612 2491 1172]
MA Jianxin [7456 1696 2450]
WANG Ren [3069 0088]

ORG: TANG and ZHU both of the Modern Physics Institute, Fudan University, Shanghai; MA and WANG both of East China Institute of Chemical Technology, Shanghai

TITLE: "The XPS Investigation of the Clean Surface and Adsorbed Surface of Perkovskite $\text{LaMn}_{1-x}\text{Cu}_x\text{O}_3$ "

SOURCE: Beijing CUIHUA XUEBAO [JOURNAL OF CATALYSIS] in Chinese No 4, Dec 84 pp 341-346

TEXT OF ENGLISH ABSTRACT: The active perovskite, $\text{LaMn}_{1-x}\text{Cu}_x\text{O}_3$ for CO oxidation has been investigated by XPS. For both the clean surface and the adsorbed surface, the measured binding energy of the core level of constituents showed no significant shift in the range of $0 \leq x \leq 0.6$. The concentrations of oxygen and lanthanum did not vary with the x value, and they kept a good stoichiometry. The concentration of copper with different x values at the outermost layer almost kept constant for the clean surface, and its amount was much lower than that of the bulk concentration, but copper segregated considerably at the very surface by the adsorption. The manganese situation was just reversed. The Cu (2p) spectra from the adsorbed surfaces showed some huge satellites, the features of which were quite similar to those of CuO, and the shake-up mechanism could not easily be assigned. Copper was confirmed to be the active center, and the action of manganese was shown by a fairly large energy shift of Mn(2p) caused by the adsorption. The C(1s) spectra indicated two separate peaks, which was consistent with the complex Cu(2p) spectra due to the adsorption. The La(3d5/2) spectra could be synthesized with three peaks. This means that there were two satellites other than the one which was usually regarded. The La(3d) spectra also implied that the effect of lanthanum might not be ignored in the chemisorption of CO. In the valence band obtained by XPS, the peak positions of the O(2p) and the VBM's showed a firm correlation with the catalytic activity which depended on the x value.

AUTHOR: LUO Yuzhong [5012 3768 1813]
FU Hongxiang [0265 0347 4382]
WANG Yunpu [3769 0061 2528]
et al.

ORG: LUO and FU both of Lanzhou Institute of Chemical Physics, Chinese Academy of Sciences; WANG, et al., of Northwest Teachers College, Lanzhou

TITLE: "Supported Metal Cluster Catalysts"

SOURCE: Beijing CUIHUA XUEBAO [JOURNAL OF CATALYSIS] in Chinese No 4, Dec 84 pp 347-354

TEXT OF ENGLISH ABSTRACT: $\text{YCCo}_3(\text{CO})_9$ and $\text{Co}_4(\text{CO})_8(\mu_2\text{-CO})_2(\mu_4\text{-PC}_6\text{H}_5)_2$ chemically bound to inorganic and polymeric support and tri-nuclear cobalt cluster entrapped into zeolite have been synthesized. Their catalytic activity for the hydroformylation of olefins has also been determined.

Five supported metal clusters synthesized are as follows:

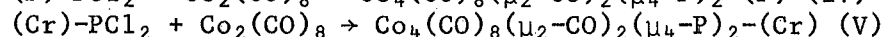
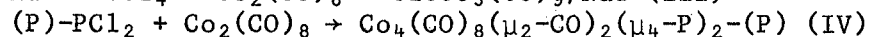
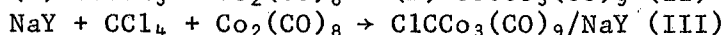
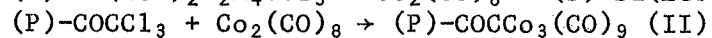
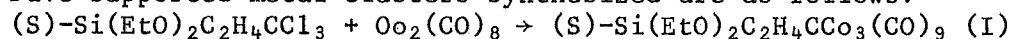

where (S) is silica gel, (P) polystyrene and (Cr) poly-dibenzo-18-crown-6.

Their infrared spectra are taken by a Type-325 grating infrared spectrophotometer, and the clusters (IV) and (V) are characterized by means of ESCA. The binding energies of $\text{Co}2p_{3/2}$ and $\text{Co}2p_{1/2}$ in supported clusters are found to be higher than those in $\text{Co}_4(\text{CO})_{10}(\text{PC}_6\text{H}_5)_2$, $\Delta E_b = +0.4$ eV for (IV), and $\Delta E_b = +0.8$ eV for (V).

All the five supported clusters described above exhibit catalytic activity for olefin hydroformylation. The catalytic activity of cluster supported on silica gel (I) is lower than that of unsupported catalyst. In the homogeneous hydroformylation reaction, by using $\text{ClCCo}_3(\text{CO})_9$ as catalyst, the conversion of hexene-1 reaches 99.3 percent after 4 hours, but the induction period of the reaction catalyzed by $\text{ClCCo}_3(\text{CO})_9/\text{NaY}$ (III) is as long as 24 hours; however, the normal/iso ratio of the product can be raised from 1.2 to 4.8 by (III). It is found that polystyrene and poly-dibenzo-18-crown-6 have some promotive effects on the catalytic activity of tetra-nuclear cobalt clusters. Using $\text{Co}_4(\text{CO})_{10}(\text{PC}_6\text{H}_5)_2$ as catalyst in the hydroformylation of hexene-1 at 130°C , the induction period is more than 11 hours, but it is reduced to 10-20 minutes by using supported cluster (IV).

AUTHOR: XUE Shunqing [5641 5293 0615]
LI Dagang [2621 6671 0474]
WU Guangsun [0702 0342 5549]

ORG: All of Lanzhou Institute of Chemical Physics, Chinese Academy of Sciences

TITLE: "In Situ IR Spectroscopic Studies of the Mechanism of Cobalt-Phosphine Catalyst Formation by Low Pressure One-Step Method"

SOURCE: Beijing CUIHUA XUEBAO [JOURNAL OF CATALYSIS] in Chinese No 4, Dec 84 pp 355-362

TEXT OF ENGLISH ABSTRACT: The mechanism of the formation of cobalt-phosphine catalyst prepared by a low pressure one-step method has been studied with high pressure in situ infrared spectrophotometry under the reaction conditions of hydroformylation. The results show that a violet phosphine coordinated coordinated cobalt salt, $(C_{10}H_{21}COO)_2Co... (PBu_3)_n$, was first formed as the solution of cobaltous naphthenate in n-heptane treated with tri-n-butyl-phosphine at room temperature, then the salt was decomposed and converted into cobalt-phosphine carbonyl complexes and naphthenic acid under the pressure of CO and H₂ and higher temperatures. The mechanism of conversion depends on the reaction pressure and the ratio of phosphine to cobalt. At low initial pressure (below 10 kg/cm²) and higher ratio of P to Co (P:Co=3:1), only $Co_2(CO)_6L_2$, $HCo(CO)_3L$ and $HCo(CO)_2L_2$ (where $L=PBu_3$) were found in the reaction mixture, and at higher initial pressure (about 20 kg/cm²) and lower ratio of P to Co (P:Co 2:1), $Co_2(CO)_7L$ and $HCo(CO)_4$ were also detected in addition to the above three complexes. But under the reaction conditions of hydroformylation, the principal complexes identified were $Co_2(CO)_6L_2$, $HCo(CO)_3L$, and $HCo(CO)_2L_2$. Under a specified condition, the phosphine coordinated cobalt salt and carboxylic acid may form a circuit of reversible reaction with cobalt-phosphine carbonyl complexes, so that the carboxylic acid in the system is favorable for the existence of the complexes.

The effects of temperature, P/Co and H₂/CO on the reaction mechanism were also studied. It is suggested that the mechanism of cobalt-phosphine catalyst formation by the low pressure one-step method may be as shown in the figure, and the active component is $HCo(CO)_3L$.

AUTHOR: SUN Laicheng [1327 0171 2052]
ZHANG Pingxi [1728 1627 6007]
XIAO Dilun [5135 1717 0243]
et al.

ORG: All of Lanzhou Institute of Chemical Physics, Chinese Academy of Sciences

TITLE: "Application of the Magnetic Driven Inner Recycling Reactor to Kinetics Study of Heterogeneous Catalysis"

SOURCE: Beijing CUIHUA XUEBAO [JOURNAL OF CATALYSIS] in Chinese No 4, Dec 84 pp 363-369

TEXT OF ENGLISH ABSTRACT: The operability of a magnetic driven inner recycling gradient free reactor, made by Lanzhou Institute of Chemical Physics, applied to three heterogeneous catalytic reactions (the oxidative dehydrogenation of butene over ferrite catalyst, the dehydrogenation of methyl cyclohexane over Pt/Al₂O₃ catalyst, and the disproportionation of toluene over zeolite catalyst), was investigated from the viewpoint of catalytic kinetics. The external diffusion, the gradients of concentration and temperature, and the reproducibility of the kinetic experimental data are discussed. In accordance with a relative concept of "gradient-free," the depth of chemical conversion, the recycling ratio in the reactor and the remainder of gradients are interrelated, indicating that in order to obtain a tolerable gradient residue that can be neglected, the recycling ratio should be greater than 50 for nearly all the experiments with depth of conversion less than 50 percent.

Under the given reaction conditions, most recycling ratios were over 100, and the concentration differences across the bed of catalysts were less than 1 percent. The temperature gradient between the surface of the catalyst and the gas phase of reactants was estimated for the oxidative dehydrogenation which had considerable thermal effect. The results showed that in such a case, the temperature difference was not greater than 1°C. The relative standard deviation of the reproducibility of kinetic experiments was less than 7 percent using only common measuring equipment.

AUTHOR: XIA Shaowu [1115 1421 2976]
DENG Conghao [6772 1783 6275]

ORG: XIA of Shandong Institute of Chemical Technology, Qingdao; DENG of the Department of Chemistry, Shandong University, Ji'nan

TITLE: "Orbital Overlap and Catalysis"

SOURCE: Beijing CUIHUA XUEBAO [JOURNAL OF CATALYSIS] in Chinese No 4, Dec 84 pp 370-377

TEXT OF ENGLISH ABSTRACT: According to the quantum theory of chemical reaction rate, the rate constant k' of the element reaction is expressed in an equation, where V_0 is the height of the potential barrier and $E\beta_i$ is the energy level of the transitional state. The rate constant k_i of the microcosmic chemical reaction is also expressed, and $Me(R)$, the electron matrix element, is defined, where $\psi_{\nu_j}(r \cdot R)$ is the electron wave function of the product states, $\psi_{\beta_i}(r \cdot R)$ is the electron wave function of the transitional state, and V_r acts as an interactive potential energy of the products.

It is seen from these equations that the main factors of influence on k' are $Me(R)$ and the total energy of the reaction system $V_0 + E\beta_i$. It is considered that the effect of catalysts on k' is principally the effect of the catalyst on both $Me(R)$ and $V_0 + E\beta_i$. In this paper, the main subject discussed is the effect of catalysts on $Me(R)$.

It is known from experience that a catalyst in a reaction participates in the formation of the transition state, which causes the change of the wave function of transition state ψ_{β_i} , then a series of changes of $Me(R)$, k_i and k' occurs.

On the basis of $Me(R)$, some catalytic reactions have been analyzed. In the case of the reaction system of point group symmetry, with $Me(R)=0$, the main effect of the catalyst is to eliminate the symmetry limitation, so as to result in $Me(R)>0$. However, for the reaction system with $Me(R) \rightarrow 0$ (close to zero), the main effect of the catalyst is to increase the value of $Me(R)$. In the case of $Me(R)>0$, the function of the catalyst is to reduce the energy of activation. It has been proved that $Me(R)$ is related to both the activity and the selectivity of the catalyst.

Because of the difficulty in calculating ψ_{ν_j} and ψ_{β_i} , a method of overlapping the orbital figures HOMO of ψ_{ν_j} and HOMO of ψ_{β_i} is chosen, which estimates the value of $Me(R)$. This method is quite different from that of the ordinary theory of Frontier Orbitals.

AUTHOR: LIN Jingzhi [2651 2529 3112]
HUANG Zhilan [7806 2535 5695]
ZHOU Wangyue [0719 2598 1471]

ORG: All of Lanzhou Institute of Chemical Physics, Chinese Academy of Sciences

TITLE: "Quantum Chemical Calculation of the Complexes of n-Butene Adsorbed on Fe-O Lattice by CNDO/2 Method"

SOURCE: Beijing CUIHUA XUBEAO [JOURNAL OF CATALYSIS] in Chinese No 4, Dec 84 pp 378-383

TEXT OF ENGLISH ABSTRACT: The adsorption of the three isomers of n-butene on Fe-O octahedral crystal has been calculated by the CNDO/2 method. Eight adsorption models of complexes, which may be formed by the n-butene molecule as a sixth ligand adsorbed on the oxygen vacancy of the Fe-O lattice, are suggested. Calculations are made for these eight adsorption states. The adsorption distances between n-butene adsorbed and the Fe³⁺ ion are optimized. For each isomer of n-butene adsorbed on the Fe-O octahedral crystal, calculations indicate that the total energy of the system for double bond adsorption is larger than the total energy of the system for single bond adsorption. The double bond adsorption energy of cis-butene-2 is the largest, and butene-1 and trans-butene-2 are in the proper order when they are adsorbed on the Fe-O lattice as the sixth ligand. In addition, the degree of difficulty of removing a hydrogen atom from each adsorbed isomer of n-butene is also calculated. Combining the activity of oxidative dehydrogenation with both the adsorption energy and the degree of difficulty of removing hydrogen atoms of each isomer adsorbed on the Fe-O lattice, it seems that of the three isomers, cis-butene-2 is the most active compound. The experimental results can be successfully explained by the calculation results.

AUTHOR: HAN Zhenhai [7281 6966 3189]
GUO Hanxian [6753 3352 6343]
SUN Yanping [1327 1750 1627]

ORG: All of the Department of Chemical Engineering, Taiyuan Institute
of Technology

TITLE: "A 'Shell Inactivation' Model of the Molten Salts of K-V Catalysts
for the Oxidation of Sulfur Dioxide"

SOURCE: Beijing CUIHUA XUEBAO [JOURNAL OF CATALYSIS] in Chinese No 4, Dec 84
pp 389-393

TEXT OF ENGLISH ABSTRACT: To describe mathematically the phenomenon that the "apparent activation energy" of the oxidation of sulfur dioxide on K-V catalysts increases abruptly at low reaction temperature, a "shell inactivation" model is suggested. It is supposed that at low reaction temperature an inactive solid state compound will separate from the active molten salts of the K-V catalyst and remain on the surface of the molten salts to form an "inactive shell," which causes a distinct increase of the diffusion resistance of gaseous reactants in the liquid phase, so that the activity of the K-V catalyst decreases suddenly at the low reaction temperature. According to this model, a reaction rate expression containing an inactive factor " ω " is formulated. The value of parameter ω at different temperatures and conversion levels can be regressed with the kinetic data.

AUTHOR: GU Shijian [0657 0013 7003]
YUAN Yuncheng [5913 0061 4453]
YANG Conggui [2799 1783 6311]

ORG: GU of Dalian Institute of Chemical Physics, Chinese Academy of Sciences; YUAN and YANG both of the Chemical Engineering Department, Dalian Institute of Technology

TITLE: "Application of Pd-Catalyst to the Synthesis of the Intermediates of New Antitumor Compound"

SOURCE: Beijing CUIHUA XUEBAO [JOURNAL OF CATALYSIS] in Chinese No 4, Dec 84 pp 397-399

TEXT OF ENGLISH ABSTRACT: In the synthesis of the intermediates, 3-(3,4-diaminophenyl)-alanine and 3-(p-aminophenyl)-alanine, of a new antitumor drug, 5 percent Pd/Al₂O₃ is an excellent catalyst both in activity and selectivity for the hydrogenation of carbon-carbon double bond and the reduction of nitro group simultaneously. The hydrogenation and reduction are carried out at 50±5°C and atmospheric pressure for 3 hours. When the amount of catalyst used is 10 percent of the reactant, the yield of the product is about 87 percent.

The catalyst can be recovered and reused. Regeneration of the catalyst involves the removing of the organic materials from the catalyst surface by washing with absolute alcohol and calcinating at 300-400°C for 2 hours. The regenerated catalyst shows an activity nearly the same as that of the fresh catalyst. The amount of the regenerated catalyst used varies from 10 to 20 percent of the reactant, with the yield of the hydrogenation product being 76 and 87 percent respectively.

9717
CSO: 4009/171

Chemistry

AUTHORS: SU Yuanfu [5685 0337 1788]
DAI Gesheng [2071 0677 3932]

ORG: Both of Huadong Chemical Engineering College

TITLE: "Separating Tungsten From Molybdenum by Synergetic Extraction"

SOURCE: Shanghai HUAXUE SHIJIE [CHEMICAL WORLD] in Chinese Vol 25 No 9,
20 Sep 84 pp 322-325

ABSTRACT: High-quality tungsten products require the smallest possible impurity levels, especially in tungsten wire. Tungsten and molybdenum are elements in the same family with very similar properties. Other approaches have been used in separating tungsten and molybdenum by solvent extraction but the authors' technique of the blended solution of S_{510} and P_{204} is the most optimal because it uses the synergetic effect in the separation process. The presence of tungsten in the blended solution is quite significant because of competition in the formation of acids of tungsten and molybdenum. When molybdenum enters the organic phase, the balance of acids in the aqueous phase shifts to the left until it finally enters the organic phase by depolymerization. Experiments show that enough extractibility still exists in the blended solution when the tungsten content is as high as 100 grams per liter. Five figures give the extraction isothermal curve for tungsten, the relationship, pH variations in the aqueous phase before and after extraction, the relationship between pH on the one hand, and D_{Mo} and D_W on the other, and the process flow chart.

One table shows the level-by-level concentration distribution of counter current extraction.

The authors thank Associate Professor Li Daozhun [2621 6670 4783] and Wang Xiaoli [3769 1420 3769/0448] of Shanghai Sulphuric Acid Plant, as well as deputy chief engineering Jia Qigeng [6751 0366 1649] of Shanghai Reagent General Plant for their help in getting solvents and dilutents; instructor Su Keman [5685 0344 2581] for assisting in the analysis of the mass spectrum of the extraction solvent; and Lin Hailin [2651 3189 2651] in preparing figures and the table.

10424

CSO: 4009/1001

Chemistry

AUTHORS: CHEN Zhenhua [7115 7201 5478]
XUAN Zidong [8983 1311 2639]
ZHANG Huashan [1728 5478 1472]

ORG: All of Department of Chemistry, Wuhan University

TITLE: "Spectrophotometric Study of Zirconium-Amino G Acid Chlorophosphonazo-Cetylpyridine Bromide"

SOURCE: Shanghai HUAXUE SHIJIE [CHEMICAL WORLD] in Chinese Vol 25 No 10,
20 Oct 84 pp 373-375

ABSTRACT: Zirconium has unique nuclear properties, as well as good anticorrosion, heat stability and catalytic characteristics; therefore, the metal is used widely in nuclear power, electronics, machine building and chemical industries. The wide applications of zirconium impose new demands on its quantitative measurements. The paper studies the conditions of measuring trace amounts of zirconium by using the amino G acid chlorophosphonazo spectrophotometric method in the presence of cetylpyridine bromide, a cationic surfactant. As found experimentally, in 2.4 N hydrochloric acid, ternary complexes of zirconium obey Lambert-Beer's Law within the range of 0 to 3 micrograms in 25 milliliters; the sensitivity is high and molar light absorption coefficient is 2.22×10^5 . The complexes are stabilized in 50 minutes or less. Zirconium measurements are not interfered by 60 times excess content of iron, 20 times excess content of magnesium, 120 times excess content of calcium, and 250 times excess content of aluminum and cobalt. The measurements are satisfactory. Two figures give the light absorption curves of amino G acid chlorophosphonazo and complexes, as well as the effect of the hydrochloric acid concentration. One table shows the effects of interfering ions when the zirconium content is 2 micrograms per 25 milliliters.

10424

CSO: 4009/1002

AUTHOR: CHEN Yihong [7115 0001 3126]
YE Meiling [0673 5019 3781]
LI Xuan [2621 3763]

ORG: All of the Institute of Chemistry, Chinese Academy of Sciences

TITLE: "On the Peak Spreading Correction in GPC. IV. The Effect of Experimental Precision and Calculating Conditions on the Result of Peak Spreading Correction"

SOURCE: Beijing GAOFENZI TONGXUN [POLYMER COMMUNICATIONS] in Chinese No 5, Oct 84 pp 346-350

TEXT OF ENGLISH ABSTRACT: The effect of computational interval ΔV , effective figure of experimental data on accuracy and precision of peak spreading correction is examined by model function in this paper. Stable solution ranges corresponding to different ΔV have been found which provide the base for selecting optimum calculating conditions.

AUTHOR: JIN Yingtai [6855 7751 3141]
LI Xingmin [2621 5281 3046]
SUN Yufang [1327 3768 5364]
et al.

ORG: All of Changchun Institute of Applied Chemistry, Chinese Academy of Sciences

TITLE: "Investigation of the Homogeneous System Based on Rare Earth Coordination Catalyst and Its Structure of Active Species. I. Polymerization of Butadiene in the Presence of $(CF_3COO)_2NdCl \cdot EtOH - Et_3Al$. II. Investigation of Active Species for $(CF_3COO)_2NdCl \cdot EtOH - Et_3Al$ System."

SOURCE: Beijing GAOFENZI TONGXUN [POLYMER COMMUNICATIONS] in Chinese No 5, Oct 84 pp 351-357, 358-362

TEXT OF ENGLISH ABSTRACT: A new type of neodymium complex is synthesized. The analytical results indicate that this compound is $(CF_3COO)_2NdCl \cdot EtOH$. A homogeneous catalyst system has been obtained from this complex combined with triethylaluminum, which gives polybutadiene containing cis-content from 78 to 98 percent.

A new bimetallic crystalline lanthanide complex which is active for polymerization of dienes has been isolated from the homogeneous solution prepared by the reaction of $(CF_3COO)_2NdCl \cdot EtOH$ with Et_3Al . A bridged structure of the lanthanide complex is proposed.

AUTHOR: XIAO Manchao [5135 3341 6389]
WEN Xiaoyao [5113 1321 3852]
DU Zuodong [2629 0155 2767]

ORG: All of the Department of Chemistry, Shandong University

TITLE: "Synthesis of γ -Substituted-Propylcyclotetrasiloxanes and Their Emulsion Copolymerizations with Octamethylcyclotetrasiloxane"

SOURCE: Beijing GAOFENZI TONGXUN [POLYMER COMMUNICATIONS] in Chinese No 5, Oct 84 pp 363-368

TEXT OF ENGLISH ABSTRACT: Four γ -substituted-propylcyclotetrasiloxanes have been synthesized. Emulsion copolymerizations of these cyclosiloxanes with octamethylcyclotetrasiloxane have been carried out in cationic and anionic emulsion systems. Via these reactions, stable emulsions of organosilicon polymers, containing carbonfunctional groups such as γ -hydroxypropyl, γ -acetoxypropyl, and γ -chloropropyl, have been obtained.

The effects of temperature, catalyst and the amount of γ -substituted propylcyclotetrasiloxanes in the emulsion copolymerizations have been studied.

AUTHOR: LIU Guozhi [0491 0948 1535]
WANG Fengjiang [3769 7685 3068]

ORG: All of Changchun Institute of Applied Chemistry, Chinese Academy of Sciences

TITLE: "Studies of the Polymerization of Butadiene in the Presence of Iron Catalyst. III. Molecular Weight Regulation and the Properties of Polybutadiene"

SOURCE: Beijing GAOFENZI TONGXUN [POLYMER COMMUNICATIONS] in Chinese No 5, Oct 84 pp 389-392

TEXT OF ENGLISH ABSTRACT: Allyl halide or benzyl chloride can greatly regulate the molecular weight of polymers during the polymerization of butadiene in hydrogenated gasoline with $\text{FeCl}_3-(i\text{-C}_4\text{H}_9)_3\text{Al-phen}$ catalyst system. It is found that allyl chloride is the most effective regulator of molecular weight among them. The $[\eta]$ of polybutadiene can be lowered from over $1.0 \text{ M}^3/\text{kg}$ to less than $0.4 \text{ M}^3/\text{kg}$ by the addition of allyl chloride, while the polymerization keeps its high yield. Polybutadiene rubber with mid-vinyl structure has been obtained with good properties.

AUTHOR: DAI Guangsong [2071 0342 2646]
LIU Lusheng [0491 7627 3932]
WU Shikang [0702 0013 1660]

ORG: All of the Institute of Photographic Chemistry, Chinese Academy of Sciences

TITLE: "Thermal Degradation of Poly(Styrene Sulfone)"

SOURCE: Beijing GAOFENZI TONGXUN [POLYMER COMMUNICATIONS] in Chinese No 5, Oct 84 pp 397-400

TEXT OF ENGLISH ABSTRACT: In this work the thermal degradation of poly(styrene sulfone) has been studied by the differential scanning calorimeter (DSC) and thermogravimetric analyzer (TGA). Poly(styrene sulfone) shows a two-step degradation mechanism, with the initial degradation occurring in the temperature range of 120-200°C and the major degradation taking place at higher temperatures. Isothermal degradation of poly(styrene sulfone) has also been studied. Above 270°C the kinetics of the thermal degradation are first order, with a activation energy of 63-64 KCal/mol. Below 270°C the kinetics are complex, with an activation energy of 14 KCal/mol.

9717
CSO: 4009/184

Chemistry

AUTHOR: SHEN Panwen [3947 3140 2429]
WANG Genshi [3076 6418 2514]
SONG Deying [1345 1795 3841]
WU Jinghe [0702 0079 0735]
WANG Fuyuan
LU Shugin
LI Shuting

ORG: Nankai University

TITLE: "Studies on the Reactions of La-Ni Master Alloy Hydrides (LaNi_4MH_n)
With Oxygen Dissolved in Water"

SOURCE: Beijing ZHONGGUO XITU XUEBAO [JOURNAL OF THE CHINESE RARE EARTH SOCIETY]
in Chinese Vo 2 No 2, Nov 84 pp 50-56

ABSTRACT: The reactions of alloy hydrides LaNi_4MH_n ($M = \text{Ni, Mn, Fe, Cu, } n \geq 3$) with oxygen dissolved in water were studied. Samples of 0.6 gram of the alloy hydrides were used in contact with each 130 ml of deionized water (oxygen content 8 ~ 10 ppm) at 25, 35, 45 and 55 °C. The time of contact was plotted against the variation of concentration of dissolved oxygen. Experimental observations showed that, (1) the alloy hydrides $\text{La-Ni}_4\text{MH}_n$ used were all effective in quantitative removal of dissolved oxygen in water. The rates of removal were in the following order: $\text{LaNi}_5\text{H}_n > \text{LaNi}_4\text{MnH}_n > \text{LaNi}_4\text{FeH}_n > \text{LaNi}_4\text{CuH}_n$, and $\text{LaNi}_4\text{FeH}_n$ (chemically synthesized) $> \text{LaNi}_4\text{FeH}_n$ (prepared from pure metals), (2) when hydrogen is in excess, the rate of reaction is in the first order with respect to the concentration of oxygen in H_2O , the apparent dynamic equation is in the form of $-\frac{d[\text{O}_2]}{dt} = k[\text{O}_2]$. The rate constants (K), apparent activation energies (E_a), and frequency factors (K_0) are listed in this paper.

CSO: 4009/1027

AUTHOR: LI Shaofen [2621 4801 5358]
 LIU Bangrong [0491 6721 2837]
 GAO Wenxin [7559 2429 2450]
 et al.

ORG: All of the Department of Chemical Engineering, Tianjin University

TITLE: "Macrokinetics of Water Gas Shift Reaction on Commercial Catalysts"

SOURCE: Beijing HUAGONG XUEBAO [JOURNAL OF CHEMICAL INDUSTRY AND ENGINEERING (CHINA)] in Chinese No 4, Dec 84 pp 303-310

TEXT OF ENGLISH ABSTRACT: The macrokinetics of water gas shift reaction on commercial iron oxide catalysts are determined. In an internal recycle gradientless reactor, types B106 and B109 shift catalysts of commercial size and cylindrical in shape, have been studied under atmospheric pressure. Reaction conditions were: temperature 250-480°C, molar ratio of steam to carbon monoxide 2 to 11, dry gas space velocity 150 to 1500 ml/(h.g.). Experimental results show that the macrokinetic equations for both catalysts can be expressed by the common formula:

$$R_{CO} = k^* p_{CO} p_{H_2O}^{0.5} \left(1 - \frac{p_{CO_2} p_{H_2}}{K_P p_{CO} p_{H_2O}} \right)$$

where p_{CO} , p_{H_2O} , p_{CO_2} and p_{H_2} are the partial pressures of carbon monoxide, steam, carbon dioxide and hydrogen, respectively, K_P the equilibrium constant of water gas shift reaction, k^* the apparent rate constant. This equation can be used in the simulation of commercial shift converters. The apparent activation energy of the B106 catalyst is 14,570 cal/mol and that of the B109 catalyst, 16,200 cal/mol. They are approximately one-half the corresponding intrinsic activation energy values, suggesting that the water gas shift reaction process is severely limited by intraparticle diffusion. However, the effectiveness factors for both catalysts, as calculated by use of the experimental results and the intrinsic rates, indicate that the apparent activity is much lower than the intrinsic activity, thereby pointing out the importance of improving the pore structure and geometry of commercial shift catalysts.

AUTHOR: PAN Renyun [3382 0088 0061]
SONG Qiuan [1345 4423 1344]
YUAN Huigen [5913 1920 2704]

ORG: All of the Department of Chemical Engineering, Zhejiang University

TITLE: "Mean Particle Size and Particle Size Distribution of Suspension Polystyrene"

SOURCE: Beijing HUAGONG XUEBAO [JOURNAL OF CHEMICAL INDUSTRY AND ENGINEERING (CHINA)] in Chinese No 4, Dec 84 pp 311-319

TEXT OF ENGLISH ABSTRACT: The effects of stirrer speed, stabilizer concentration, ratio of dispersed to continuous phase, diameter of reactor and stirrer type on the mean particle size and particle size distribution have been investigated. The results can be correlated by

$$\frac{\bar{d}_{32}}{D} = 4.56We^{-0.44}\phi^{0.40}\left(\frac{\eta_d}{\eta_c}\right)^{2.50}$$

This equation provides a fundamental basis for polymerization reactor design and selection of its optimum operating conditions.

AUTHOR: YU Hongshou [0060 7703 1108]
ZHANG Manchao [1728 3341 3390]
XIAO Chengji [5618 2052 1015]

ORG: All of the Sixth Design Institute, Ministry of Chemical Industry

TITLE: "Hydrodynamics of Large-holed Sieve Trays"

SOURCE: Beijing HUAGONG XUEBAO [JOURNAL OF CHEMICAL INDUSTRY AND ENGINEERING (CHINA)] in Chinese No 4, Dec 84 pp 344-356

TEXT OF ENGLISH ABSTRACT: Hydrodynamic data of sieve trays with hole diameters of 5, 10, 15, 20 and 25 mm were experimentally obtained and studied. A set of equations to correlate pressure drop, weeping velocity, entrainment and froth height was established, and was considered precise enough for design requirements. The performance and operating flexibility of large-holed sieve trays were studied and discussed. It can be shown that for properly designed sieve trays, operating flexibility can be achieved with a loading ratio of 2 to 4, which is adequate for fluctuation of commercial-scale columns.

AUTHOR: JIAO Shuke [3542 2579 4430]
HU Liping [5170 0500 1627]
SHAN Jianhui [0830 7003 2585]
et al.

ORG: All of Beijing Institute of Chemical Technology

TITLE: "Adjusting Function of α -Olefine During Preparation of Liquid Polybutadiene Based on Cobalt Catalyst"

SOURCE: Beijing HUAGONG XUEBAO [JOURNAL OF CHEMICAL INDUSTRY AND ENGINEERING (CHINA)] in Chinese No 4, Dec 84 pp 357-367

TEXT OF ENGLISH ABSTRACT: Liquid polybutadiene (cis-1,4 = 45-60 percent, trans-1,4 = 10-40 percent, vinyl = 15-40 percent, $\bar{M}_n = 1500-6000$) was prepared by using $\text{Co}(\text{naph})_2\text{-Al}(\text{Bu})_3\text{-PhCCl}_3$ as the catalyst, extract gasoline as the solvent and ethylene, propylene and isobutene as the molecular weight regulator. The effects of α -olefine to butadiene molar ratio, polymerization temperature, monomer concentration and polymerization time on conversion, number-average molecular weight and microstructure of the product were investigated. The adjusting mechanism of α -olefine was proved.

AUTHOR: JIANG Tiqian [3068 7555 0051]
CHU Jiaying [5969 1367 3841]
XU Yingnong [1776 5391 6593]

ORG: All of East China Institute of Chemical Technology

TITLE: "Experimental Study of Mass Transfer in Film Flow of Non-Newtonian Fluids"

SOURCE: Beijing HUAGONG XUEBAO [JOURNAL OF CHEMICAL INDUSTRY AND ENGINEERING (CHINA)] in Chinese No 4, Dec 84 pp 368-374

TEXT OF ENGLISH ABSTRACT: Mass transfer in the falling film of laminar non-Newtonian liquid was studied experimentally. A wetted column was used to measure the rate of absorption of carbon dioxide in aqueous polymer solutions, the rheological behavior of which is well characterized by the power-law model.

The experimental results showed that the exact solution of the differential equation of diffusion, which considers the velocity distribution in the falling film of non-Newtonian power-law fluids, are proper. It was found that for pseudoplastic fluids, it is adequate to use the dimensionless length $Z < 0.1$ as the criterion for the applicability of the penetration theory, for which the exact expressions would be applicable for the entire range of the dimensionless length.

AUTHOR: WANG Haozhong [3769 6275 1813]

ORG: Beijing Institute of Chemical Technology

TITLE: "Heat Transfer Coefficient and Power Requirement in Helical Ribbon Mixers"

SOURCE: Beijing HUAGONG XUEBAO [JOURNAL OF CHEMICAL INDUSTRY AND ENGINEERING (CHINA)] in Chinese No 4, Dec 84 pp 375-380

TEXT OF ENGLISH ABSTRACT: An experimental study of the rate of heat transfer in helical ribbon mixers and its relationship with power requirement is described. Four ribbon impellers and eight test fluids of different consistencies and ranging from pseudoplastic non-Newtonian to highly viscous Newtonian were used in the experiment.

It was found that the heat transfer coefficient is a function of impeller geometry at a Reynolds number less than about 0.1. Accordingly there are four correlations corresponding to the four ribbon impellers. At a Reynolds number higher than 10, the heat transfer coefficient is independent of impeller geometry and a single correlation is therefore obtained for all four impellers.

Since both the heat transfer coefficient and power consumption are functions of Reynolds numbers, a relationship is presented between them.

9717

CSO: 4009/170

Communications

AUTHOR: ZHANG Lihe [1728 4409 0735]
QIAN Shoulian [6929 1343 1670]*
[* Hangzhou Municipal Institute of Postal Service Studies]

ORG: None

TITLE: "Application of Spectral Moment Analysis for Speech Recognition"

SOURCE: Hangzhou HANGZHOU DAXUE XUEBAO (ZIRAN KEXUE BAN) [JOURNAL OF HANGZHOU UNIVERSITY (NATURAL SCIENCES EDITION)] in Chinese Vol 12 No 1, Jan 85 pp 57-61

ABSTRACT: The application of spectral moment analysis for speech recognition is described. Original information is obtained from a digital dynamic spectral analyzer which gives the speech spectral data. The information is compressed by a method called spectral moment distance criterion. In this way the main information representing the features of the speech is extracted. The recognition rate of the method of Chinese digits 0 to 9 approximately reached 99.8 percent.

CSO: 4009/1029

AUTHOR: ZHANG Shouxuan [1728 1108 5503]

ORG: Shipbuilding Technology Research Institute, China State Shipbuilding Corporation

TITLE: "System C--An Integrated Multi-functional Chinese Language Information Processing System"

SOURCE: Beijing JISUANJI XUEBAO [CHINESE JOURNAL OF COMPUTERS] in Chinese
Vol 7 No 6, Nov 84 pp 401-412

TEXT OF ENGLISH ABSTRACT: A multi-functional Chinese language information processing system running on the super-mini-computer WANG VS-100 is introduced. The design consideration and system development are discussed. The data structure of Chinese editor CED, an automatic text paging formatter CRF, an automatic table generator CTB, a Chinese database interface Cbase and a new query strategy, Query By Screen (QBS), are given as well.

AUTHOR: None

ORG: GF20/11A Research Group, Institute of Computing Technology, Chinese Academy of Sciences

TITLE: "GF20/11A Chinese Character Microcomputer System"

SOURCE: Beijing JISUANJI XUEBAO [CHINESE JOURNAL OF COMPUTERS] in Chinese Vol 7 No 6, Nov 84 pp 413-417

TEXT OF ENGLISH ABSTRACT: The GF20/11A is a multiple function microcomputer system specifically designed to meet the particular requirements of Chinese character processing. It is equipped with a relatively large RAM and disk memory capacity, and various Chinese character and graphic I/O devices. The Chinese character operating system is fully compatible with the CP/M 2.2, with the extension of Chinese character processing ability and automatic scheduling of RAM and disk memory. Both the Chinese character and English alphabet can be recognized at the operating system level and can be treated equally. It is equipped with extensive Chinese character processing communication and application software. Various hardware and software design problems are discussed in detail.

AUTHOR: WANG Xuan [3769 6693]
LU Zhimin [0712 0037 2404]
CHEN Zhumei [7115 4554 2734]
TANG Yuhai [3282 3768 3189]
et al.

ORG: WANG, LU and CHEN all of Beijing University; TANG, et al., of Weifang Computer Factory

TITLE: "Augmentation and Reduction for Chinese Character Images with High Resolution"

SOURCE: Beijing JISUANJI XUEBAO [CHINESE JOURNAL OF COMPUTERS] in Chinese Vol 7 No 6, Nov 84 pp 418-426

TEXT OF ENGLISH ABSTRACT: Data compression techniques for Chinese character images play an important role in computerized editing and laser typesetting systems. The character sizing method used in the system described is one of the principal measures of achieving a high overall compression ratio. Different scaling methods are adopted for both regular strokes and irregular strokes of Chinese characters and steps are taken to guarantee the quality during scaling. Bipolar PROM, bit-slice microprocessor and a microprogramming technique are used to increase sizing speed and to reduce hardware cost. This system costs less than \$100.

AUTHOR: WANG Xuan [3769 6693]
LU Zhimin [0712 0037 2404]
XIANG Yang [0686 7122]
TANG Yuhai [3282 3768 3189]

ORG: WANG and LU both of Beijing University; XIANG and TANG both of Weifang Computer Factory

TITLE: "Generation of Page Layout of Chinese Books and Newspaper Microprocessors"

SOURCE: Beijing JISUANJI XUEBAO [CHINESE JOURNAL OF COMPUTERS] in Chinese Vol 7 No 6, Nov 84 pp 427-435

TEXT OF ENGLISH ABSTRACT: Difficulties caused by the raster output nature of laser systems are overcome by hardware-software integrated system design. The design method of such a system is described in this paper. Compressed Chinese fonts are stored hierarchically and the characters in current use are selected from the disc and transmitted to the local memory of the character generator; therefore, no access to the font disc is required during the output of a whole book. A new method of describing the page layout and a new technique of generating characters section by section are used. The Am 2900 bipolar bit-slice microcomputer plays an important role in obtaining high generating speed at low cost.

AUTHOR: CHEN Shengfan [7115 0524 0416]
PU Wenchu [3184 2429 0443]
ZHANG Li [1728 0500]
et al.

ORG: All of the Chinese Computer Technology Service Company

TITLE: "Operating System and Data Base System for Chinese Characters"

SOURCE: Beijing JISUANJI XUEBAO [CHINESE JOURNAL OF COMPUTERS] in Chinese
Vol 7 No 6, Nov 84 pp 436-444

TEXT OF ENGLISH ABSTRACT: The implementations of a Chinese character operating system and relational data base system on microcomputers are discussed in this paper. The existing operating system is expanded so that Chinese data processing is possible. The Chinese relational data base can be supported by the Chinese operating system. The work presented in this paper will facilitate Chinese character processing on microcomputers.

AUTHOR: WU Baokun [0702 1405 0981]
WU Zhenyi [0702 2182 4135]
WANG Maojiang [3769 2021 3068]
et al.

ORG: All of Beijing Document Service

TITLE: "Preliminary Investigation of Developing a Process of Chinese Character Information in Time-sharing Systems"

SOURCE: Beijing JISUANJI XUEBAO [CHINESE JOURNAL OF COMPUTERS] in Chinese
Vol 7 No 6, Nov 84 pp 445-450

TEXT OF ENGLISH ABSTRACT: This article discusses a protocol emulation approach in which Chinese character terminals and Chinese character processing functions can be incorporated into large-scale time-sharing computer systems.

AUTHOR: XIE Kezhong [6200 0344 0022]
C.Y. Suen

ORG: XIE of Central South China Institute of Mining and Metallurgy;
Suen of Concordia University, Montreal, Canada

TITLE: "Design of Chinese Character-Generating System and Compression of
Chinese Character Image Data"

SOURCE: Beijing JISUANJI XUEBAO [CHINESE JOURNAL OF COMPUTERS] in Chinese
Vol 7 No 6, Nov 84 pp 451-457

TEXT OF ENGLISH ABSTRACT: The basic problems in designing a complete
Chinese character-generating system are discussed. A practical approach to
compression of Chinese character image data, the "stroke element method,"
is also proposed and discussed.

AUTHOR: WANG Jiesheng [3769 0094 3932]

ORG: Institute of Computing Technology, Chinese Academy of Sciences

TITLE: "A Branch and Bound Algorithm for Logic Partitioning Problem"

SOURCE: Beijing JISUANJI XUEBAO [CHINESE JOURNAL OF COMPUTERS] in Chinese
Vol 7 No 6, Nov 84 pp 458-472]

TEXT OF ENGLISH ABSTRACT: The tree structure of the solution set for a logic partitioning problem and some matrix inequalities relating to the total amount of pins is presented. A branch and bound algorithm for the problem has been established. The results have been applied to the logic design of a large-scale computer.

AUTHOR: YANG Dailun [2799 0108 0243]
WU Guanghan [1566 0342 3352]

ORG: Both of the Institute of Nuclear Science and Technology, Sichuan University

TITLE: "A Method of Treatment of Integration and Differentiation in Analytical Derivation of Kernels on Computer"

SOURCE: Beijing JISUANJI XUEBAO [CHINESE JOURNAL OF COMPUTERS] in Chinese Vol 7 No 6, Nov 84 pp 473-480

TEXT OF ENGLISH ABSTRACT: In the microscopic study of the interaction of complex nuclei, in order to derive the RGM kernel analytically with the double Fourier transformation and the complex generator coordinate technique, tremendous integral and differential operations have to be performed. In this paper, these are automatically done on a computer with a new method.

9717
CSO: 4009/199

Electronics

AUTHOR: WU Xunwei [0702 6064 1218]
ZHUANG Nan [8369 0589]
HU Guoan [5170 0948 1344]

ORG: None

TITLE: "Ternary COINCIDENCE Operation and Its TTL Circuit Realization"

SOURCE: Hangzhou HANGZHOU DAXUE XUEBAO (ZIRAN KEXUE BAN) [JOURNAL OF HANGZHOU UNIVERSITY (NATURAL SCIENCES EDITION)] in Chinese Vol 12 No 1, Jan 85 pp 62-69

ABSTRACT: Ternary threshold operation and ternary COINCIDENCE operation are introduced. A circuit design of the TTL ternary "NOT-COINCIDENCE Gate" is proposed.

CSO: 4009/1029

Electronics

AUTHOR: ZHONG Shunshi [6988 7311 2514]

ORG: Northwest Telecommunication Engineering Institute

TITLE: "Bandwidth and Broadbanding of a Rectangular Microstrip Antenna"

SOURCE: Beijing DIANZI KEXUE XUEKAN [JOURNAL OF ELECTRONICS] in Chinese
Vol 7 No 2, Mar 85 pp 98-107

ABSTRACT: Based on the cavity model theory, a set of simple formulas and graphs for calculating both the radiation pattern bandwidth and the impedance bandwidth of a rectangular microstrip antenna are presented with experimental verification. Three kinds of approaches to broaden the bandwidth and their potentiality are reviewed and discussed. A simple broadband technique by means of combination of stub-matching and increasing the antenna thickness is developed. A test element with the thickness of 0.05 wavelength has been matched by using two stubs, while the input VSWR is measured to be less than 2 : 1 over a 13-percent bandwidth.

CSO: 4009/1024

AUTHOR: HAI Yuhan [3189 1342 3211]
ZHOU Zhongyi [0719 1813 3015]

ORG: Institute of Electronics, Chinese Academy of Sciences

TITLE: "Spectra Effect of Anomalous Transient Response in α -Si:H Film"

SOURCE: Beijing DIANZI KEXUE XUEKAN [JOURNAL OF ELECTRONICS] in Chinese
Vol 7 No 3, Mar 85 pp 108-113

ABSTRACT: Transient photoresponse spectra in α -Si:H film with sandwich structure are measured. It is found that at the starting part of these curves, anomalous pulse appears under either a small forward bias or a small reverse one. The pulse amplitude decreases when the light wavelength increases. Analysis of the transient response spectra without bias, showed that this anomalous non-transport component originates from the barrier region. Its rise or decay characteristic is determined by space-charge-limited photocurrents. With the relation between its amplitude and optical absorption, we developed a method to obtain optical band gap of the films studied.

CSO: 4009/1024

AUTHOR: YANG Xiancheng [2799 0341 4468]
JIN Ruliang [6855 1172 5328]

ORG: Institute of Electronics, Chinese Academy of Sciences

TITLE: "A Study of the Domain Structure of (Sm, Gd, Er) Co₅ by the Magneto-Optical Kerr Effect"

SOURCE: Beijing DIANZI KEXUE XUEKAN [JOURNAL OF ELECTRONICS] in Chinese
Vol 7 No 2, Mar 85 pp 114-120

ABSTRACT: A study of the magnetic domain structure of (Sm, Gd, Er) Co₅ magnet by magneto-optical Kerr effect is presented. Two samples with different intrinsic coercive forces are compared to one another in their variations in the domain structure during different stages of magnetization and demagnetization.

The results indicate that the coercivity of the magnet made of this kind of magnetic material is mainly controlled by nucleation mechanism. Hence, to improve its magnetic properties, the reversal magnetized nucleation must be restrained. In practice, it can be done by keeping the composition of magnetic materials accurate and homogeneous, increasing the density of the magnet, decreasing the content of impurity and hole, etc....

CSO: 4009/1024

AUTHOR: LU Shengxun [7120 3932 8113]
ZHU Jiasheng [2612 0502 3932]

ORG: Hangzhou University

TITLE: "An Algorithm To Find 1-Factors of a Coates Graph"

SOURCE: Beijing DIANZI KEXUE XUEKAN [JOURNAL OF ELECTRONICS] in Chinese
Vol 7 No 2, Mar 85 pp 144-151

ABSTRACT: This paper continues the study in the author's former paper [see this journal Vol 4 No 3, May 82 p 198]. According to the theorem for generating 1-factors by star product described in former paper, we consider a class of special graphs at first, for which the relations between star product and permutation are established and then the relations are extended to the general case. Finally, we give an algorithm to find the 1-factors of a Coates graph.

CSO: 4009/1024

AUTHOR: ZHOU Wenbiao [0719 2429 5903]

ORG: Institute of Electronics, Chinese Academy of Sciences

TITLE: "Frequency Characteristics of Suspended Microstrip Line"

SOURCE: Beijing DIANZI KEXUE XUEKAN [JOURNAL OF ELECTRONICS] in Chinese
Vol 7 No 2, Mar 85 pp 152-157

ABSTRACT: The suspended microstrip line is used widely in the microwave integrated circuits due to its low loss property and large size. The frequency characteristics of suspended microstrip lines are analyzed by using the spectral domain immittance approach. The characteristic impedance and relative guided wavelength curves are given for different dielectric materials.

CSO: 4009/1024

Petrochemical Industry

AUTHORS: MEI Yunfu [2734 0336 4395]
GOU Naibo [5384 0035 0590]

ORG: MEI of Wuxi Resins Plant; GOU of Qingdao Petrochemical Plant

TITLE: "Dry Vacuum Distillation"

SOURCE: Shanghai HUAXUE SHIJIE [CHEMICAL WORLD] in Chinese Vol 25 No 9,
20 Sep 84 pp 334-336

ABSTRACT: In China, one-stage distillation of crude oil generally yields 25 to 30 percent recovery in gasoline, kerosene and diesel oil. In order to prevent high-temperature decomposition of residual heavy oil in the heating furnace and pressure-reducing tower and the adverse effect on the distilled oil quality, superheated steam is admitted into the furnace tube and tower; this traditional vacuum distillation is called the wet type. Advances in dry vacuum distillation in recent years without the admission of steam for operation at even lower residual pressures can boost the yields of gasoline, diesel oil and petrochemical raw materials. If this dry method is widely adopted in China, the economic benefits in petroleum refining will be 600 million yuan or more per year: specifically, more than 500 million yuan for a gain of 1,225,000 tons of gasoline and diesel oil, and some 86 million yuan for a savings of 641,000 tons of fuel oil in heating furnaces for a feedstock of 70 million tons of petroleum refined a year. There are also the advantages of higher tower productivity and greater operational flexibility. Generally, the maximum production capacity of the dry type vacuum distillation tower (per square meter of cross sectional area) is 31,000 to 41,300 tons of crude diesel oil per year.

The authors thank the following individuals for their assistance and counsel: chief engineer Zhang Yushi [1728 0645 4258] of Jinling Petrochemical General Corporation, factory superintendent Qiu Guoqi [6726 0948 0892] of Luoyang Experimentation Plant of the above-mentioned corporation, chief engineer Zhu Renyi [2612 0086 5030] of Gaoqiao Petrochemical General Corporation (Shanghai), deputy chief Sun Bairen [1327 4102 1804] of Wuxi Chemical Industry Bureau, and engineers Jiang Hu [1203 3338], Wu Xiangchen [0702 3276 5256], and Ji Gang [1323 6921] of Wuxi Resins Plant.

10424
CSO: 4009/1001

Microbiology

AUTHOR: HUANG Jianping [7806 0256 1456]
YANG Chanjun [2799 5848 0689]
TANG Weizhen [0781 3555 5271]
ZHOU Guofang [0719 0948 5364]

ORG: Zhongnan College of Forestry, Zhuzhou, Hunan Province

TITLE: "Analysis of Esterase Patterns of *Bacillus Thuringiensis* var. *indiana* and *B. t.* var. *kyushuensis*"

SOURCE: Beijing WEISHENGWUXUE TONGBAO [MICROBIOLOGY] in Chinese No 3, Jun 84
pp 97-99

ABSTRACT: This paper reports studies of esterase patterns of 18 variations of *Bacillus Thuringiensis*, the sera of which were supplied by Hunan Provincial Research Institute of Microbiology and Wuhan Virology Research Institute. Of the 18, 2 *Bacillus Thuringiensis* var. *indiana* and *Bacillus Thuringiensis* var. *kyushuensis*, have not been studied before. A DYY-III instrument was used for polypropylene aminoacyl gel electrophoresis. The esterase patterns of all 18 varieties, including the two that are different from those previously described, are reproduced, and their Ef values computed. A table listing all 18 varieties, their esterase patterns, and the supplier of each of the sera for the study, is included.

6248
CSO: 4009/192

Microbiology

AUTHOR: LU Kaiguo [7627 7030 0948]

ORG: Rushan County Public Health and Epidemic Prevention Station, Shandong Province

TITLE: "Preliminary Studies of Biological Characteristics and Pathogenicity of *Yersinia enterocolitica*, Y.E.C., Isolated From Colon of Pig"

SOURCE: Beijing WEISHENGWUXUE TONGBAO [MICROBIOLOGY] in Chinese No 3, Jun 84 pp 107-109

ABSTRACT: Although direct isolation of Y.E.C. from humans is rare, its human pathogenicity has been reported in many countries. In the spring of 1981, local pigs were examined for Y.E.C. Y.E.C was not found from specimens collected from the surface of tongues but 14 strains were isolated from the colon. The pigs had no obvious symptoms of any sickness and no obvious disorder was found in the internal organs either. Perhaps Y.E.C. is not significantly pathogenic to pigs. Tests on the cornea of guinea pigs with 10 of the strains indicate that only one of the strains is mildly pathogenic. All the strains express various degrees of invading capacity in human kidney cell tests. These strains may have provided a condition for studying the relationship between Y.E.C. and some locally prevailing diseases. Biochemical reaction tests and drug sensitivity tests are also briefly reported.

6248

CSO: 4009/192

Microbiology

AUTHOR: XIAO Xinling [5135 6932 1545]
WU Xinlan [0702 2450 5695]
SHI Xuanlin [4258 1357 0109]
LI Jiawu [2621 1367 2976]
WANG Shuxian [3769 3219 8300]

ORG: Zhangchun Biological Products Research Institute, Ministry of Public Health, Zhangchun

TITLE: "Studies on the Isolation and Selection of Toxin-High Producing Strain of Bacillus diphtheriae"

SOURCE: Beijing WEISHENGWUXUE TONGBAO [MICROBIOLOGY] in Chinese No 3, Jun 84 pp 109-112

ABSTRACT: The B. diphtheriae strain, PW8, commonly used here and abroad to manufacture B.D. toxin has a high natural variability rate and the isolation of toxin high-producing secondary strains has been reported by other scientists. This paper reports the successful isolation from PW8-Weissensee by the authors of a secondary strain, producing 47.25 percent higher toxin than the original strain which had been supplied by Rumania. The process of isolation and selection and results of production use, toxicity tests, etc are described briefly in the paper.

6248
CSO: 4009/192

Microbiology

AUTHOR: CUI Qinglu [1508 1987 4389]
DONG Qing [0392 7230]
GUO Xiulan [6751 4423 5695]
YAN Zhaomin [0917 0340 3046]
WU Congya [0702 1783 0068]

ORG: Inner Mongolia Autonomous Region Research Institute of Prevention and Treatment of Endemic Diseases, Huhehaote

TITLE: "Differentiation of 142 Strains of Brucella"

SOURCE: Beijing WEISHENGXUE TONGBAO [MICROBIOLOGY] in Chinese No 3, Jun 84
pp 114-117

ABSTRACT: In 1979, 142 strains of Brucella were isolated from sheep specimens of 6 brigades of Aobantai Commune; they belong to 6 biological types of both sheep or cow varieties. In the past, both sheep (M5) and cow (A19) vaccines have been applied to local animals. In order to determine whether this practice was the cause of the presence of such a large number of strains and mutants in such a small locality, a project was carried out to differentiate these strains. Results indicate that these are natural strains and not the vaccine ones. They do not induce disease in humans or animals, but they can cross-infect humans and animals and be retained in the host bodies. Toxicity and antibiotics sensitivity tests are also carried out and reported.

6248

CSO: 4009/192

Microbiology

AUTHOR: WANG Ying [3769 3841]
WEN Ji [3306 3381]
FENG Xichang [7458 0823 2490]

ORG: Research Institute of Zoology Chinese Academy of Sciences, Beijing

TITLE: "New Records of Varieties of Bacillus Thuringiensis in China"

SOURCE: Beijing WEISHENGWUXUE TONGBAO [MICROBIOLOGY] in Chinese No 6, Dec 84
pp 244-246

ABSTRACT: From the soils of China, the following 5 strains of Bacillus Thuringiensis have just been isolated: L, Bacillus Thuringiensis canadensis), 7902 (Bacillus Thuringiensis entomocidus), 8302, 8303 (Bacillus Thuringiensis aizawai), 10-4-13 (Bacillus Thuringiensis tolworthi). Of these, L, can produce crystals and pigment and can utilize manna sugar, 10-4-13 does not produce β exotoxin. Except for L, and 7902, the remaining are toxic to armyworms and cotton bollworms. These five strains belong to four serum types, all new records in China. According to de Barjac's classification, there are 27 varieties of Bacillus Thuringiensis belonging to 20 serum types. So far, only nine serum types have been discovered in China. A great deal of work still awaits.

6248
CSO: 4009/196

Microbiology

AUTHOR: WU Jixing [0702 4949 2502]
CHEN Zaier [7115 0961 0086/5101]

ORG: Tianmen County Research Institute of Microbiology, Hubei Province

TITLE: "Production and Application of Bacillus Thuringiensis Products"

SOURCE: Beijing WEISHENGWUXUE TONGBAO [MICROBIOLOGY] in Chinese No 6,
Dec 84 pp 273-276

ABSTRACT: The use of Bacillus Thuringiensis in biological control of insects since 1930 is briefly reported. In China Bacillus Thuringiensis products were first introduced in 1959. By 1970, plants manufacturing Bacillus Thuringiensis agents began to be established in several provinces. The two major methods of manufacturing these products and the six important steps in the production process are described. In 1976, China was producing close to 1,000 tons of such products, almost the same as in the U.S. By 1980, the cost of production was reduced in the U.S. and production rose to 4,000 tons. In the same year, the production in China dropped to 100 tons and not very many of the original 60 plants remained operative. Ways of standardizing the quality of the products, reducing the cost of production, and improving the technique of application to raise the insect control effects are discussed.

6248
CSO: 4009/196

Microcomputer

AUTHORS: ZHANG Chunbao [1728 2504 1405]
YU Shiquan [0205 2514 2938]

ORG: Shanghai University, Engineering College

TITLE: "Introduction to Specialties of NEWDOS80 Floppy Disk Operating System"

SOURCE: Beijing WEIJISUANJI YINGYONG [MICROCOMPUTER APPLICATIONS] in Chinese Vol 6 No 1, Jan 85 pp 1-11

ABSTRACT: NEWDOS 80 V.1.0 is a single-task operating system developed for the TRS-80 microcomputer hardware environment by the Apparat Company. The system is an upgraded edition compatible with NEWDOS+ V.2.1 and TRSDOS V2.3. The system has been transplanted to a domestically manufactured MIC-80 microcomputer. The NEWDOS 80 disk operating system has a hierarchical structure. The nucleus layer consists of initial bootstrap and keyboard, display and printer programs. The second layer contains the system nucleus, including disk I/O driver, system call, interrupt management, tables, buffers, etc. and functions somewhat like CP/M BIOS. The third layer contains the cover call module for processing the functional systems. NEWDOS 80 V.1.0 adopts the basic design of CP/M but expands system call commands and adds realtime combined key operating commands. The realtime combined key operating commands call up the DEBUG program, MINI-DOS subsystem, and screen print program. An APPEND command has been added for file merge. A CHAIN command has been added to produce chained files, a feature borrowed from UNIX. A SYSTEM command has been added to permit toggling certain system functions when the disk system is booted, allowing the user to configure the system variously depending on the situation. A PDRIVE command permits the user to redefine the disk format.

8226
CSO: 4009/198

Microcomputer

AUTHOR: ZHANG Hanting [1728 3352 0080]
ORG: Chinese Academy of Sciences, Electrical Engineering Institute
TITLE: "Information Compression Program COMPRESS"
SOURCE: Beijing WEIJISUANJI YINGYONG [MICROCOMPUTER APPLICATIONS] in
Chinese Vol 6 No 1, Jan 85 pp 45-49

ABSTRACT: Information compression saves on memory and transmission time and it can have an impact on the memory requirements, form and echo rate of a Chinese character library. COMPRESS is a utility program written in BDS-C language for CP/M. The program uses the Huffman algorithm which scans a file, counts the probability of a character appearing, then builds a tree by sorting these probabilities by the quick sort method. The COMPRESS program itself is modular, consisting of a master control, initialization, probability, tree production, code production, compression and expansion modules. Compression ratio tests using the programs yielded compressed files which were 34.3 percent to 44.6 percent smaller than the original files. Tests were also conducted establishing that a file which had been compressed and then expanded again was identical to the original, precompression file. Since in CP/M file management, memory is allocated in units of 1K, actual effective compression is lower than the computational value. The number of different characters used in a file influences the depth of the Huffman tree and the length of the compression code. In tests on a dummy file, expansion and compression time was about 24 seconds/K, but this time could have been reduced by a larger capacity buffer.

REFERENCES

Yan Weimin [0917 5588 2404] and Shen Peijuan [3088 0160 1227], SHUJU JIEGOU [DATA STRUCTURES], Guofang Gongye Chubanshe.
Ito Makoto and Takehara Fujiko, ZAISHIN BISEIKI HENTEI GIHO [LATEST MICROCOM-PUTER PROGRAMMING TECHNIQUES], Intaafueiisu, August 1979.

8226
CSO: 4009/198

TAIWAN

BRIEFS

DRAM WAFER DEVELOPMENT--The Republic of China has successfully developed a 256k CMOS DRAM, the world's third nation to accomplish the feat, the Industrial Technology Research Institute (ITRI) announced Thursday. ITRI said Hitachi of Japan and Intel of the United States first successfully developed the product last September but it took them a longer time to accomplish the feat than this nation. ROC's 256k CMOS DRAM (Dynamic Random Access Memory) wafer was jointly developed by ITRI's Electronics Research and Service Organization (ERSO) and Vitelic Taiwan Corp. The product has a 6-inch diameter and contains 200 chips, each with the equivalent of more than 265,000 transistors. It has passed all electronic specification tests and has proven superior to the NMOS DRAM in reliability, ITRI said. Vitelic will start production of the new product before the end of next year and is expected to hold a 10 percent market share in 1988 when world demand for the chips will amount to U.S. \$4 billion. The company's initial monthly output will be 20,000 wafers. [Excerpts] [Taipei CHINA POST in English 20 April 85 p 12 OW]

64K CMOS EPROM CHIP--Taipei, 11 May (CNA)--United Microelectronics Corporation (UMC) and MOS Electronic Corporation (MOSEL) have announced the successful joint development of a 64k CMOS EPROM computer chip, according to an official of UMC. CMOS EPROM, which stands for Complementary Metal Oxide Semiconductor Erasable Programming Read-Only Memory, is an advanced chip which can permanently store computer programs or data until users want to reuse, rewrite, or reprogram such material. Simply put, this ability is far different from Random Access Memory (RAM), which is stored in a computer only until the power is switched off. The 64k CMOS EPROM chips are said to be one of the most advanced computer products in the world today. Firms in the United States and Japan were previously the only manufacturers of such products; the Republic of China will take its place as third. [Text] [Taipei CNA in English 0935 GMT 11 May 85 OW]

CSO: 4010/1005

END