

JPRS-WST-84-030

7 SEPTEMBER 1984

WEST EUROPE REPORT

SCIENCE AND TECHNOLOGY

DISTRIBUTION STATEMENT A
Approved for Public Release
Distribution Unlimited

FOREIGN BROADCAST INFORMATION SERVICE

DTIC QUALITY INSPECTED 3

REPRODUCED BY
NATIONAL TECHNICAL
INFORMATION SERVICE
U.S. DEPARTMENT OF COMMERCE
SPRINGFIELD, VA. 22161

1 9990414072

59

NOTE

JPRS publications contain information primarily from foreign newspapers, periodicals and books, but also from news agency transmissions and broadcasts. Materials from foreign-language sources are translated; those from English-language sources are transcribed or reprinted, with the original phrasing and characteristics retained.

Headlines, editorial reports, and material enclosed in brackets are supplied by JPRS. Processing indicators such as (Text) or (Excerpt) in the first line of a brief, indicate how the original information was processed. Where no processing indicator is given, the information was summarized or extracted.

Unfamiliar names rendered phonetically or transliterated are enclosed in parentheses. Words or names preceded by a question mark and enclosed in parentheses were not clear in the original but have been supplied as appropriate in context. Other unattributed parenthetical notes within the body of an item originate with the source. Times within items are as given by source.

The contents of this publication in no way represent the policies, views or attitudes of the U. S. Government.

PROCUREMENT OF PUBLICATIONS

JPRS publications may be ordered from the National Technical Information Service, Springfield, Virginia 22161. In ordering, it is recommended that the JPRS number, title, date and author, if applicable, of publication be cited.

Current JPRS publications are announced in Government Reports Announcements issued semi-monthly by the National Technical Information Service, and are listed in the Monthly Catalog of U. S. Government Publications issued by the Superintendent of Documents, U. S. Government Printing Office, Washington, D. C. 20402.

Indexes to this report (by keyword, author, personal names, title and series) are available through Bell & Howell, Old Mansfield Road, Wooster, Ohio, 44691.

Correspondence pertaining to matters other than procurement may be addressed to Joint Publications Research Service, 1000 North Glebe Road, Arlington, Virginia 22201.

7 September 1984

WEST EUROPE REPORT SCIENCE AND TECHNOLOGY

CONTENTS

ADVANCED MATERIALS

- Swedish Research in High-Temperature Ceramics, Superalloys
(Ulf Bergmark; NY TEKNIK, 26 Apr 84)..... 1

AEROSPACE

- French Joint Venture for Digital Image Processing
(AFP SCIENCES, 19 Jul 84)..... 6

Briefs

- Italy Participates in Ariane-V 7

BIOTECHNOLOGY

- EEC Announces Community Program in Biotech
(BIO LA LETTRE DES BIOTECHNOLOGIES, May 84)..... 8

- EEC Project for Biotech Data Storage Outlined
(BIOFUTUR, Jun 84)..... 9

- London Biotech Conference Attracted 600 Participants
(BIOFUTUR, Jul 84)..... 11

- Strategy of Corning Biotechnology Europe Viewed
(Jean-Bernard Borfiga Interview; BIO LA LETTRE DES
BIOTECHNOLOGIES, May 84)..... 13

COMPUTERS

- Status of French Supercomputer Projects Isis, Marianne
(Jean-Marc Chabanas; ZERO UN INFORMATIQUE HEBDO,
20 May 84)..... 16

Briefs		19
CGE Artificial Intelligence Work		
FACTORY AUTOMATION		
FRG Robotics Firm To Market Products in U.S.		20
(EEE, 19 Jun 84).....		
French Firm Uses Unique Flexible Workshop With Laser Cutter		22
(Michel Defaux; L'USINE NOUVELLE, 5 Jul 84).....		
Sweden: Optical Fiber Carries Laser Power for Welding		25
(Jan Segerfeldt; NY TEKNIK, 26 Apr 84).....		
MICROELECTRONICS		
Denmark Starts 4-Year Microelectronics Program		27
(Sigyn Alenius; FORUM, 13 Jun 84).....		
French CNET Aims at Commercial Submicron Technologies by 1986		29
(ELECTRONIQUE ACTUALITES, 13 Apr 84).....		
Thomas Semiconducteurs Creates Military Division		32
(ELECTRONIQUE ACTUALITES, 20 Apr 84).....		
SCIENTIFIC AND INDUSTRIAL POLICY		
Curien Named French Minister of Research, Technology		34
(Various sources, various dates).....		
New Minister's Background		
Personnel Changes, Policy Outline		
Brief Interview, Hubert Curien Interview		
Statements in LE MONDE, by Maurice Arvonny,		
Elisabeth Gordon		
Jeumont-Schneider Takes Stock of Products, Finances		40
(Philippe Douroux; L'USINE NOUVELLE, 28 Jun 84).....		
Swiss Introduce Tax Breaks, Insurance for Innovators		42
(Alois Altenweger; TECHNISCHE RUNDSCHAU, 17 Jul 84).....		
FRG Support of 'Manufacturing Technologies' R&D Outlined		44
(Jochen Hiebel; CAE MANAGEMENT, Jun 84).....		
Briefs		46
FRG Venture Capital Plentiful		

TECHNOLOGY TRANSFER

Increase in Industrial Espionage Reported in Sweden (Bertil Ekerlid; SVENSKA DAGBLADET, 23 Jul 84).....	47
FRG Computer Firm Gets Venture Capital, Starts Branch in U.S. (ELEKTRONIKPRAXIS, May 84).....	51
Brussels Newspaper Comments on Technology Transfer Dilemma (Pol Mathil; LE SOIR, 27 Jul 84).....	52
Briefs	
VW Invests in Yugoslavia	54

ADVANCED MATERIALS

SWEDISH RESEARCH IN HIGH-TEMPERATURE CERAMICS, SUPERALLOYS

Stockholm NY TEKNIK in Swedish 26 Apr 84 pp 34-35

[Article by Ulf Bergmark]

[Text] A powder that is sprayed on the inside of jet engines can help produce faster, more energy-efficient planes.

Hoganas AB is one of the few manufacturers of this powder in the world. The company is involved in a project that will make Swedish industry a world leader in the production of energy-efficient, wear-resistant jet engines and gas turbines.

Oil is becoming more expensive and its quality is declining. For this reason, manufacturers of jet engines around the world are investing heavily in engines that are more fuel-efficient and wear-resistant. In theory, it is easy to construct a more fuel-efficient jet engine: just use higher pressures and temperatures in the engine!

But our present knowledge of materials places certain temperature restrictions on engines. In the Viggen fighter, which has a modern jet engine, the maximum temperature is about 1,300°C. The JAS will have an engine capable of withstanding almost 1,400°C.

"Increasing the permissible engine temperature an additional 100°C would be a major advance. It would provide a higher power yield and produce fuel savings of 5 to 8 percent," said Leif Larsson and Jan Wigren of Volvo Flygmotor. Volvo builds the engines for Swedish military planes.

Ceramic Layer

These energy savings and perhaps more are possible if the rotating parts in the engine are coated with a thin layer of ceramic material, such as zirconium dioxide.

But a "glue" is needed to make the ceramic stick to the metal turbine blade. Volvo is now experimenting with so-called MCrAlY alloys, which are capable of serving as this "glue." The alloy is a powder that is applied to the turbine blade by plasma spraying.

The M stands for metal. This is usually nickel or cobalt. The Swedish and American industries are now working hard to develop alloys with iron. The Cr stands for chromium, Al for aluminum, and Y for yttrium.

A surface treated with MCrAlY has many positive properties. It is heat-resistant, resists corrosive and eroding environments, and has a coefficient of heat expansion between metals and ceramics. These are the qualities that make MCrAlY a good "ceramic glue."

Protect

It is the low thermal conductivity of the ceramic materials that permits the higher temperature in the engine. The ceramics protect the underlying metal.

The corrosion resistance of the "glue" will become more and more essential as the quality of jet fuel declines. The chromium and aluminum oxides are responsible for the corrosion resistance. The yttrium helps strengthen the structure of the oxides and increase adhesion.

So far, no aircraft manufacturer has coated an engine's turbine with ceramic material. Experts at Volvo Flygmotor believe it will take at least 5 years before this technique is commercially feasible. Modern jet engines already have many static parts that are coated with MCrAlY and a ceramic material, however.

Composites

In the more distant future, jet engines will be made of heat-resistant materials that will not need coatings. Researchers in the United States are experimenting with various superalloys and composites. Eventually, turbines will probably be made of pressed and sintered ceramic materials.

Until these superengines are produced, industrial gas turbines may be coated with MCrAlY alloys to give them improved properties.

Asea-Stal recently initiated a project to construct a turbine that will resist corrosive and abrasive gases from coal combustion.

This turbine is part of Asea's PFBC (pressurized fluidized-bed combustion) project. The goal is to produce a coal-fired condensing plant in which the coal is burned in a pressurized fluidized bed. PFBC technology may provide high efficiency and low sulfur emissions. So far, however, there is no large boiler in operation that uses this technology.

The combustion gases from a coal-fired boiler contain sulfur, which is highly corrosive, and particles that erode the turbine blades.

A gas turbine lasts almost 10 times as long if its blades are coated with MCrAlY. No additional ceramic layer is needed, since a higher operating temperature is not one of the goals.

"We do not yet know which MCrAlY coating is best," said Lars Josefsson of Asea-Stal.

Nickel provides the densest and most brittle coating. It is also heat-resistant.

Cobalt increases the mechanical strength, but diffusion, i.e. permeability, increases.

Tougher

Iron makes the surface even tougher, but unfortunately it increases the diffusion problem, thereby exacerbating corrosion of the underlying material. But iron provides good protection against sulfuration--the formation of sulfur compounds on the surface.

Researchers have worked most with nickel. It has been used commercially in jet engines for 3 years. However, recent research in the United States has shown that nickel coatings can crack. The projects at Volvo Flygmotor and at Asea-Stal are supported by STU (Technical Development Board). The results are analyzed in conjunction with the Linkoping Technical University. Hoganas produces the various MCrAlY alloys and Kanthal Coating is developing the iron-based alloys.

The iron-based MCrAlY is now receiving the greatest attention. This coating is not yet fully developed. Prof Torsten Eriksson of the Linkoping Technical University believes that the iron-based MCrAlY could become a Swedish specialty product.

Plasma Spraying

For 4 years, Prof Torsten Eriksson has led a project that is investigating coating techniques and subsequent treatment.

He has found that plasma spraying followed by hot isostatic pressing provides the best surface.

In plasma spraying, the powder is fed into a gas jet that is so hot that the atoms no longer stay together: they form a plasma. The temperature is about 15,000°C. The small grains melt on the surface and form a relatively dense layer. Its porosity is about 5 to 15 percent.

Plasma spraying can also be done under a vacuum or with a protective gas around the plasma. In this case, the individual grains are not oxidized and the porosity may be reduced to 1 or 2 percent, sometimes even lower.

Hush-Hush On Production

The powder that is capable of producing more efficient jet engines is manufactured at a secret experimental facility in Hoganas.

This plant, which is one of the most advanced of its kind in the world, is

shrouded in secrecy. Yet, it does not look unusual in any way. The "can," which is two stories high, is small by the standards of metallurgy plants and production is carried out by hand.

But powder metallurgy cannot be compared to classical metal production. A yearly production of several hundred tons of powder for surface coating is sufficient to make the small experimental plant profitable.

Advanced

The advanced-technology powder of nickel, cobalt, and sometimes of iron costs 100 to 600 kronor per kilogram.

Next to the pilot plant, there is a larger production facility with a capacity of 1,200 tons per year. It produces somewhat simpler high-alloy materials.

The process used there is called gas atomization. The name is actually somewhat misleading, since the individual grains of powder are never smaller than 5 μm .

The plant was constructed so that Hoganas could compete for a share of the market in deoxidized powders of all kinds.

The production process is as follows:

The raw material, the metals that are to be included in the alloy, is melted in a high-frequency furnace. The charge weighs between 50 and 150 kg.

The melt is poured into the top of the atomization chamber and is allowed to run down through a small hole.

Jets of argon, helium, or nitrogen divide the metal stream into small parts. The powder particles are formed in this way. This requires enormous quantities of gas, which is sprayed in under high pressure.

Cooled In Water

The powder can be cooled in water containing silicon and boron or in a gas. Throughout the process, oxygen is kept out by a protective gas. If the individual powder grains are allowed to oxidize in the air, they lose their ability to bind together.

After the powder has solidified, the dust is removed in a cyclone. Then the particles that are too large or too small are screened out. About 15 to 40 percent of each batch is usable. The rest is remelted under a vacuum.

Hoganas is studying both the feed system for the atomizing gas and the cooling process. It is possible to vary the gas pressure over a wide range, but no exact description of the process has been revealed.

Surface Coating

Gas-atomized powder from Hoganäs is used primarily for surface coating by flame spraying or plasma spraying. The MCrAlY powder is the most advanced of these powders.

The individual grains are extremely spherical when they are produced at the gas-atomization facility. As a result, they flow readily through a spray nozzle.

Surface coating with powders is a rapidly growing process and Hoganäs is now able to sell as much powder as it produces.

"We export 95 percent of all the powder we produce," said Leif L'Estrade, head of the experimental facility at Hoganäs.

Another rapidly growing market is copying powder. It is produced by simpler technology. Hoganäs is conducting a project in this area together with a Japanese manufacturer of copiers.

9336

CSO: 3698/566

AEROSPACE

FRENCH JOINT VENTURE FOR DIGITAL IMAGE PROCESSING

Paris AFP SCIENCES in French 19 July 84 p 9

[Article: "SEP and CSEE Have a Controlling Interst in Numelec"]

[Text] Paris--The European Propulsion Comapny (SEP) and the Electric and Electronic Signal Company (CSEE) have just acquired a controlling interest of FF 4 million in Numelec, it was announced on 19 July by SEP.

Numelec specializes in digital image processing and nuclear instruments. Its sales are expected to reach close to FF 50 million in 1984.

People at the SEP indicated that the Industrial Development Institute (IDI) will contribute to finance the operation through its SDI (Suez Industrial Development) subsidiary, which will subsequently acquire Numelec stock, some of which is still held by former shareholders.

This operation, it was pointed out, is designed to constitute a French pole in digital image processing by bringing together the operations of Numelec, SEP and CSEE which complement one another in this field. The CSEE was also chosen by the Ministry of Industry and Research for the National Display Plan.

Digital image processing has many applications. They include, in particular, space remote sensing, the display of images in industrial and medical fields, and computer-aided design.

Mr Rene Morin, head of the Image Processing Division of SEP was appointed chief executive officer of Numelec. Mr Morin is 57 years old, a bachelor of science and a graduate engineer from the Higher National School for Mechanics and Aerotechnics; after spending several years with the European Atomic Energy Commission, he joined the Missile and Space Division of SNECMA [National Aircraft Engine Study and Manufacturing Company] in 1966, as head of the Department of Advanced Engineering and Space. In 1969, he became head of the technical departments of that division.

In 1971, he was appointed commercial manager of SEP and, in March 1983, manager of image processing at the same company.

AEROSPACE

BRIEFS

ITALY PARTICIPATES IN ARIANE-V--Italy agreed to participate in the European Ariane-V space program, the French prime minister, Mr Pierre Mauroy, announced Friday, after meeting in Rome with his Italian counterpart, Mr Bettino Craxi. "In the short term, Italy will participate in the development of the HM-60 cryogenic engine and in the European remote-sensing satellite project," Mr Mauroy added at a joint press conference following his conversations with Mr Craxi. The prime minister also pointed out that, in the longer term, France was interested in the Italian-German Columbus manned module project. He also said that, for its part, Italy had shown some interest in the European orbital station project mentioned by the president of the French republic, Mr Francois Mitterrand, in his speech at The Hague. As far as the military is concerned, Mr Mauroy went on, France and Italy have agreed to work together on a transport helicopter project. This aircraft would be in the 8-ton range, we learned from a diplomatic source. [Text] [Paris LES ECHOS in French 3 Jul 84 p 7] 9294

CSO: 3698/559

BIOTECHNOLOGY

EEC ANNOUNCES COMMUNITY PROGRAM IN BIOTECH

Paris BIO LA LETTRE DES BIOTECHNOLOGIES in French May 84 p 5

[Text] After concentrating on electronics, data processing and telecommunications, the Committee of the European Economic Community has just adopted a 5 year plan (1985-89) for the development of research in biotechnology which will be submitted for the approval of the 10 member countries. Its cost is estimated at 88.5 million ECUs (1 ECU = \$0.86). The decision comes exactly 6 months after the European ministries concerned gave their approval to the second stage of the biomolecular engineering program, which cost much less since 8 million ECUs were set aside for it when it was begun in 1981, and 7 million ECUs are earmarked for this second stage.

With a view to closing the gap between the member states and Japan and the United States, the proposed new program aims to provide the Community with an infrastructure and a critical mass for research and training in basic biotechnology, to promote the transfer to European industry of the materials and information arising from modern biology, and to develop cooperation between member countries in new technological developments, of which one is biotechnology.

A European council for biotechnology in Europe, CUBE, (Consultancy Unit for Biotechnology in Europe) will have the task of analyzing international economic and legislative developments which might have an impact on the development of the European biotechnological industry. At the top of the list of priorities is the formation of a European biocomputerization network; a computer network for gathering information in molecular biology (collection of cell cultures, plasmids and virus banks, nucleic acid and protein sequences, etc.) from all areas of Europe would be established.

Research and development programs in which Brussels believes Europe has fallen behind will be given special support.

The present biomolecular engineering program will be extended from six to nine fields, the three new fields dealing with: the stability of microorganisms in fermentors with special mention of mixed cultures; the physiology and biochemistry of basic functions such as the assimilation of nitrogen, the resistance of cultures to diseases; finally, new methods of screening and of the study of the activity of biological molecules.

BIOTECHNOLOGY

EEC PROJECT FOR BIOTECH DATA STORAGE OUTLINED

Paris BIOFUTUR in French Jun 84 p 27

[Article: "'Bio-informatics': A European Project"]

[Text] From an article by Mark Cantley* to appear soon in SWISS BIOTECH, we take the following extract on "Bio-informatics" with the consent of the author.

The committee for scientific and technological information and documentation (CIDST) has organized a task force for biotechnological information whose work program is summed up below. Its resources are modest as yet, but its European scope may serve as a catalyst and improve the effectiveness of national efforts in this area.

<u>Project</u>	<u>Cost in ECUs for the Commission</u>
1. European nucleic sequences bank: EMBL Heidelberg and measures to facilitate access to it and to develop its spread.	50,000
2. European information on biotechnology and reference center: UK Science Reference Library in collaboration with DIMDI (Germany) and CDST (France).	63,000
3. Feasibility of a computerized system of EEC collections of microorganism cultures: Environmental Resources Ltd in consultation with the Pasteur Institute, Marcel van Dijk (Brussels), ECCCO.	18,000

* Commission of the European Communities; Consultation Unit for Biotechnology in Europe, 200 rue de la Loi, B-1049, Brussels.

<u>Project</u>	<u>Cost in ECUs for the Commission</u>
4. Feasibility of a European information system on enzymes and enzymatic engineering: University of Compiègne.	10,000
5. Working group of "MIRDAB" (Microbiological Resources Data Bank) for European collections of cells and viruses: Excerpta Medica (Amsterdam) and EFCVC (European Federation of Cell and Virus Collection).	8,000
6. Study to realize an initial inventory of the potentialities of toxicological studies on invertebrates (in consultation with the Irish National Board for Science and Technology	25,000

9824

CSO: 3698/549

BIOTECHNOLOGY

LONDON BIOTECH CONFERENCE ATTRACTED 600 PARTICIPANTS

Paris BIOFUTUR in French Jul 84 p 14

[Text] London 15, 16, 17 May. When it comes to conferences or exhibitions, it is interesting to measure what the benefit is to the organizer and what to the subject dealt with.

Biotech Europe 84, organized by Online, is an example of this.

The prevalent opinion on this conference tended to be one of disappointment. It must be remembered that Biotech was cut in half (another conference is to be held in Washington this September) and this obviously resulted in much fewer Japanese and Americans coming than was the case last year.

Exhibitors Aspect

The large multinational consumer (and producer) companies in biotechnology, even the English ones (ICI, for example) did not come, waiting perhaps for Washington.

The Japanese exhibitors (who came in 1983) did not come either.

Apparently, only one French company withdrew.

By contrast, the number of exhibitors, about 80 in 1983, rose to around 100 this year (with a lot of medium-sized English businessmen). This is an encouraging sign of the development of a market in the biotechnology of products, equipment and technology.

The exhibitors generally regretted the insufficient number of visitors.

Conference Members Aspect

It was mainly for them that Biotech was organized, but there were only about 600 of them (so fewer than last year), including nearly 80 conference member authors, of whom many were Americans; accordingly, there was much discussion of American biotechnology.

The reading of the reports demonstrated the quality of some contributions, particularly French ones (Joel de Rosnay, Pierre Feillet, Pierre Monsan, Claude Gudin, etc.).

But the general opinion was that the conferences were only "marginally superior" to those of 1983.

It is not self-evident that the division of Biotech in two is favorable to interprofessional exchange in biotechnology, still fragmentary and in the beginning stages.

For all that, Biotech provided opportunity for active professional encounter, an important factor in itself.

9824

CSO: 3698/549

BIOTECHNOLOGY

STRATEGY OF CORNING BIOTECHNOLOGY EUROPE VIEWED

Paris BIO LA LETTRE DES BIOTECHNOLOGIES in French May 84 pp 1-3

[Interview with Jean-Bernard Borfiga, General Manager of Corning Biotechnology Europe]

[Question]: Mr Borfiga, at the very least, Corning Glass did not seem to have any interest in getting involved and investing in biotechnology. What led your company to diversify in this field, especially in Europe?

[Answer]: There were a number of factors that led Corning to become interested in biotechnology a few years ago. Corning is traditionally a company that sells technology and bases its growth on strong research and scientific or technical breakthroughs. Among the sectors with good growth prospects are, of course, the life sciences and communications. Corning has been involved in these sectors since 1974: in biology, through Corning Medical and Scientific which markets analytical instruments and diagnostic kits; and in communications through a major program to develop and manufacture fiber optics.

Then why "industrial biotechnology"? Once again, there is a technology factor:

The company's Consumer Products Division is interested in the basic question of fixing proteins on inorganic surfaces (glass, ceramics), with a view to obtaining a minimal "attachment" of food to these surfaces. The biologists hired by Corning to work on this have, by showing the advantages of fixing "useful" proteins, opened the way to the technology of immobilizing enzymes on porous surfaces.

The first commercial development was in 1974, when the world sugar crisis led the corn industry to develop high fructose corn syrups (HFCS). In cooperation with one of the firms working on this project, Corning participated in the technological and industrial development of HFCS production using immobilized isomeric glucose.

Around the same time, finally, the cheese industry interested Corning in developing an enzymatic procedure to transform lactoserum, a pollutant by-product of this industry, into a sweetener. For market reasons, it was decided that this operation would be done in Europe and that this technology

would be marketed together with the producers of the raw materials. To this end, two joint ventures were established in Europe with the Milk Marketing Board in England and the Normandie Dairy Union in France.

Through its technology branch, Corning got into the fermentation business by buying the enzymes division of Rohm and Haas, and obtained access to genetic engineering by buying into Genentech and joining that company in establishing Genencor, a joint venture in the field of recombinant enzymes.

Still through its technology sector, Corning developed a system for immobilizing mammal cells which enabled them to start marketing a system to allow for the birth of these cells.

Access to the market was then obtained by acquiring KC Biological, an American firm that markets culture mediums.

[Question]: So now you are fully involved in biotechnology. What are Corning's current objectives in this field and what share of the market do you expect to have in the near future?

[Answer]: Corning has just made a number of strategic decisions which, in the area of biotechnology, will involve the decentralization of research work outside Europe to the subsidiaries we have referred to, and research by technical and financial partners.

If I were to try to define Corning's position to you, I would say first of all that our company has invested a great deal in the research and development of technologies, each of which has the potential of generating markets of over 100 million, if a creative policy for financing the growth is applied.

I would like to add two more things, the first of which is particularly important to me. We would have expanded our operations in the field of lactoserum much further in France if the regulatory problems had been resolved more professionally and diligently. Although Corning Europe is based in France, it is in England where the first industrial unit to hydrolyze lactose was built.

The second is that biotechnology will not be the company's main source of income, as traditional activities and developments in fiber optics are still priority areas.

[Question]: You have said in the past that biotechnology is not a business sector in itself, but a parallel and sometimes competitive alternative to other traditional technologies. Could you explain this view?

[Answer]: First let me say something very trite: biotechnology only exists because of its markets.

A company of 20 PhD's, 15 technicians, administrative personnel and equipment operates in the field of biotechnology when it markets its research by supplying industrial firms with the "tools" they may need: recombinant organisms, fixed organisms, monoclonal antibodies, etc....

The true issue is related to the use of these tools by a given firm. It may be tempted to "diversify in biotechnology," although I am happy to see that this approach--which was popular partly because it was in fashion and partly because of the capacity to buy a dream--is disappearing. I think that this approach was relatively senseless.

It is clear, however, that one may want to diversify in a sector where biotechnology techniques could bring a competitive edge.

It is also possible to make a strictly financial investment, and this is entirely respectable if this is a firm's strategy.

Finally, biotechnology can be used by firms to lower their production costs.

Important progress in analyzing investments in biotechnology (either technical or financial ones) has been made in recent years, and has helped clarify ideas and solidify the market.

[Question]: You are part of a company of American origin, but you are a European manager in biotechnology. You therefore can give us a non-nationalistic view. In your opinion, has France made a good start in the field of biotechnology?

[Answer]: France may not have the best chance of assuming an important place in the industrial use of biotechnology, for well-known reasons:

- (1) Structure of the financial market, which is not conducive to high-risk investments. The recent moves made by the government, however, are a step in the right direction.
- (2) Few entrepreneurs, who are given very little incentive because of a tax system which is more repressive than its competitors.
- (3) The absence of links between universities and industry.
- (4) A lack of confidence in technology transfer companies.
- (5) A regulatory apparatus which is not conducive to innovation.

These constraints encumber the persistent efforts by governmental working groups such as the Douzou-Durand Mission, or inter-professional groups such as ADEBIO.

France, however, can be proud of some highly competitive international enterprises, such as SANOFI and TRANSGENE.

Is this enough or should this country, like the United Kingdom before it, resign itself to having this basic science be commercialized by other countries?

9805
CSO: 3698/557

COMPUTERS

STATUS OF FRENCH SUPERCOMPUTER PROJECTS ISIS, MARIANNE

Paris ZERO UN INFORMATIQUE HEBDO in French 20 May 84 p 10

[Article by Jean-Marc Chabanas: "Three French Projects in Search of Megaflops"]

[Text] Undertaken by the Ministry of Defense in cooperation with the Ministries of Telecommunications and of Industry and Research, the Isis (Bull), Marianne (Sintra) and Marisis (Bull-Sintra) projects should lay out the French course toward true supercomputers between 1986 and 1988.

Supercomputers, the stars of scientific computation and the essential moving force in nuclear research, the petroleum industry and artificial intelligence, are few in number. The current products (Cray 1, Cyber 205) and the projects of American specialists--Cray Research and Control Data--are of course well known.

Less famous is another American project, Denelcor, which recently appeared in France (see 01 HEBDO No 768, 26 September, 1983). The Japanese, of course are not standing still, and "large-scales" are an important part of the fifth generation.

In France it was the Ministry of Defense, and more precisely, the Directorate of Research, Study and Technology (DRET) which in 1981 established a program for large-scale computers and which now coordinates the industrial tasks in close cooperation with the civil ministries (MIR [Ministry of Industry and Research] and PTT).

Introduced in detail precisely one year ago during the "National Science and Defense Days," the Isis and Marianne projects--supplemented by the Marisis project--should produce the first prototypes in mid-1986.

At what stage are these projects today?

Let us recall first of all that the review of different French needs in the area of scientific computation--for national defense and otherwise--led to similar specifications: a large number of partial derivative equations solved by approximation methods. In other words, the classic field of parallel computation, mostly vectorial, on a large quantity of data.

The Means to the End

The problem can be solved by appropriate computer architectures, without having to devise ultra-sophisticated technologies. On the technological level alone--not to mention the natural desire for independence--France was therefore capable of setting out upon this "path to power."

After consultation with different French enterprises, two projects were launched in 1981-82: Isis, granted to Bull (then known as CII-HB) and Marianne, directed by Sintra; then, since October 1982, Marisis, fruit of the combined effort of Bull and Sintra, and which is going to supplement the first two projects which are still being developed.

These projects, the total cost of which will run to hundreds of millions of francs, were originally under the direction of the Ministry of Defense. Since last year the Ministry of Industry has also been participating to an increasing degree.

100 Megaflops for Isis

Isis, the project granted to Bull, should result in a prototype by mid-1986. This prototype will have a power of roughly 100 Megaflops ["millions of floating point operations per second"]. This figure, which may seem modest, deserves some explanation.

First of all, Isis is a SIMD [single instruction multiple data stream]-type machine, conceived mainly for vectorial computations using 64-bit words. It works on an M1 common memory (memory of 8 million words on 16 interlaced banks, cycle time of 60 nanoseconds each). A central scalar unit sorts the instructions and processes everything that is not vectorial. Vectorial computations are carried out by elementary processors (numbering from 8 to 64).

Each processor is itself designed on a four-level pipeline structure, thus assuring a floating operation (addition or multiplication) in 30 nanoseconds. The theoretical power of such a processor (a mock-up has been in existence for more than a year) is thus 33 MFlops. Sixty-four parallel processors would therefore result in more than 2,000 MFlops, a figure fully competitive with those that abound in Japanese and American literature.

In reality it is necessary to take into account the inevitable scalar computations (for which the power cannot exceed a few tens of Mips) and the maximum throughput of the M1 memory, now limited to 266 million words/second (16 words per 60 ns). Allowing that each floating point operation requires one access in memory, the power could not exceed 266 MFlops.

These considerations explain the prudence of the designers and the stated objective of 100 MFlops with 64-bit words. It should be added that, in practice, the power supplied is in the range of 30-40 MFlops for the Cyber 205 or the Cray 1, 80 MFlops for the Cray XMP (for which models already exist in 1984).

It should be noted that Isis will still use an M3 auxiliary memory (100 million words to a disk) and a standard machine (a DPS7) for the management of peripherals.

It will be programmed in Fortran, for which two compilers have been developed: a so-called "vectorial" Fortran, accessible to users who will agree to break their problem down themselves into instructions concerning vectors, and a so-called "vectorizing" Fortran which automatically breaks down the problem (it, of course, will be less effective).

A Language for Marianne

The Marianne project, granted to Sintra, should also bring out a sample model in mid-1986. The project has to do essentially with a MIMD [multiple instruction multiple data] machine, that is, it processes in parallel tasks which are not necessarily vectorial. In other words, it is up to the programmer, in the noble sense of the word, to break down this program into independent tasks which can be executed in parallel and to indicate how they are to be chained.

Along with developing a machine, Marianne was thus supposed to concern itself with a control language, allowing this deviation into tasks. The project was finally limited to a simple demonstration model using existing processors, but above all developing the language (called LC2) to prove the validity of the principles.

On the hardware level, there remains the comparative study of two possible structures, the one with local memory on the level of each of the processors, the other with only common memory.

Marisis in 1988

Born a short time later, the Marisis project (its name is a contraction of Marianne and Isis) is intended to be a joint effort. Bull is developing a fast machine, mainly for vectorial computation; Sintra is developing a language and a method of parallel processing for each type of computation.

Marisis, which could produce a prototype by the second half of 1988, thus joins together the two projects.

The processors will be derived from Isis either in undercoupling (each having its own memory, M1 in this case, whereas the M2 memory remains divided among all Isis) or in overcoupling on a common memory. The control language will be derived from LC2, therefore giving rise to the possibility of segmenting the program into tasks which can be executed in parallel but will not necessarily be vectorial.

One last word about the hoped-for performance. 200 MFlops on 64-bit words and several hundred million words (of 64 bits) of shared memory. We'll see in 1988.

12686
CSO: 3698/511

COMPUTERS

BRIEFS

CGE ARTIFICIAL INTELLIGENCE WORK--For the upcoming year the CGE is preparing a specialized computer designed for artificial intelligence applications. Capable of processing tree-like information (neither digital nor vectorial), it will be three times faster than a LISP-type machine. It will be connected to an advanced terminal including a 768 x 1024 point screen (high resolution), with 16 windows. The price will be roughly 700,000 francs. It is designed to compete with American Lisp or Vax hardware which is currently used for these applications. This project, developed at the Marcoussis laboratories, is called MAIA. [Text] [Paris INDUSTRIES ET TECHNIQUES in French 20 May 84 p 10] 12686

CSO: 3698/511

FACTORY AUTOMATION

FRG ROBOTICS FIRM TO MARKET PRODUCTS IN U.S.

Leinfelden-Echterdingen EEE in German 19 Jun 84 p 4

[Article: "Know-How Transfer Across the Atlantic: GdA Awards Exclusive Dealership"]

[Text] Munich (R).--Prab Robots of Kalamazoo, Michigan--with more than 2,000 different robot installations in more than 400 applications in the United States and one of the leading manufacturing-automation companies--and the Digital Automation Company (GdA), Munich, recently signed an agreement concerning technical cooperation and the exclusive distribution of GdA robots in the United States.

According to this contract, Prab will purchase several hundred GdA handling robots of types HDS 05/06, HDS 24/26 and HDS 34/36 in the next 5 years and in the process received the exclusive distributorship for the United States.

The American company sees in the GdA robots an important addition to its own product line. Orders are already in hand from several leading American auto makers for GdA units.

"For us this agreement means," acknowledges GdA business manager Dr-Ing Peter Hagemann, "primarily a distinct increase in our robot production; for such a large number of systems as the American market promises cannot be sold in Germany nor in all of Western Europe. After assuring our long-term financing through capital raising actions, we see the joint effort with Prab as a further, important step toward establishing GdA as an important manufacturer of robots."

The advantage in this lies also in direct access to Prab's comprehensive applications and know-how library, from which GdA and the domestic market will surely profit.

Prab has acquired special experience in such areas as robot tools and peripherals. Several hundred different grippers have already passed through the Michigan factory.

The Munich-based Digital Automation Company mbH, even though active for only 2 years in the robot market, has already won for itself more success than mere recognition. In this time its manipulators have been installed in a variety of factories in the automobile and aircraft industries and in many medium-sized companies.

9160

CSO: 3698/543

FACTORY AUTOMATION

FRENCH FIRM USES UNIQUE FLEXIBLE WORKSHOP WITH LASER CUTTER

Paris L'USINE NOUVELLE in French 5 July 84 pp 43-44

[Article by Michel Defaux: "Sheetwork: Aldes Associates a Flexible Line and a Laser"]

[Text] To solve the problem of fabricating complex sheetmetal parts in small and medium series, Aldes just acquired a flexible line equipped with a laser cutting system that is unique in Europe.

Located in the Lyons area, Aldes, a leader in the field of mechanical ventilation (325 people, 1983 sales of FF 134 million), just acquired a flexible sheetwork line with a laser cutting system that gives the company a two or three years' lead on its competitors. A financial risk (the total investment amounts to FF 6 million) and a technical risk as well, as many pieces of equipment are prototypes. But that was the only way to solve the company's many problems: it had a finished-product catalog of 2,500 items, including 1,500 just for network accessories (tees, connection joints). The latter, which include characteristic intersecting cylinders, used to be manufactured on request in a sheetwork shop: they were hand-drawn from a template, cut with shears and a nibbler, rolled, welded and profiled... An artisanal job involving a lot of in-process inventories, average production times of one week, and a demand that could vary in the ratio of one to two. The requirement analysis revealed a production of 3,000 cylinders per day, for over 100 different orders, to be completed in 24 to 48 hours.

Multiple Sources of Savings Thanks to the Laser

"Three years ago, we learned about the cutting laser, Bruno Lacroix, chief executive officer, remembers. "That tool could solve all our problems." Actually, with a laser it is possible to fabricate many parts needed for other products manufactured in medium-size series, to reduce in-process inventories and spare parts, and to avoid the costly acquisition of press-cutting tools.

Among the original features of the 15-m-long flexible line of Aldes, we should mention: the dual intake laser cutting table developed by Limoges Precision (as soon as the laser is done with its coil work, it automatically starts cutting sheetmetal); the utilization of the first Cilas-series laser with a 1,000 W power output for cutting; the use of a local network to connect

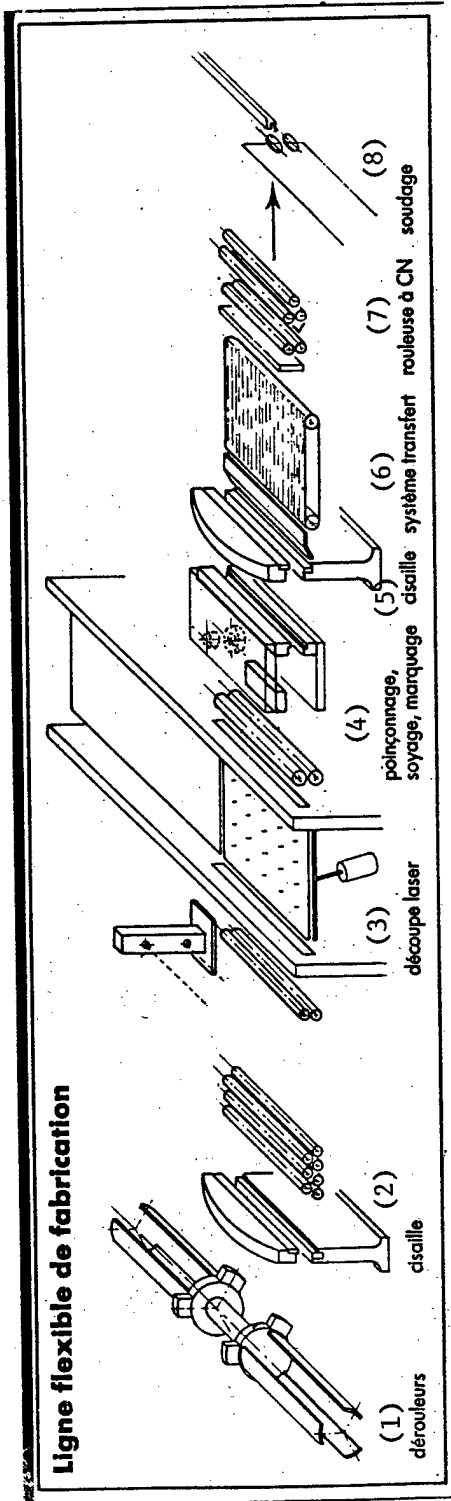

Flexible Fabrication Line: the sheetwork flexible line with laser cutting should enable Aldes to achieve material savings of 3 to 4 percent and a productivity improvement of 20 to 50 percent on 3 typical parts.

Key:

- 1. Unroller
- 2. Shearing machine
- 3. Laser cutting
- 4. Punching, bending, marking
- 5. Shearing machine
- 6. Transfer system
- 7. Numerical-control rolling machine
- 8. Welding

numeric controls, programmable controllers and machines; not to mention new machine tools. "As far as equipment is concerned, we had to adapt older existing machines or even create new ones," Michel Marillac, technical manager, pointed out. "Thus, when the project started, numeric controls were seldom controlled by a computer. CN Industrie [Numeric Control Industry] developed a computer-controlled Num 560 cabinet specially for us." Another "big job" consisted in setting up files: storing contour shapes in memory, setting up a part-assembly file to obtain standard widths (waste reduction, reduction of the number of rolls), and the files containing the machining parameters (laser, rolling, welding).

Problems had to be solved before the line could start: "The main problems had to do with the laser adjustment--in particular sheet monitoring by the cutting head--and the reliability of the local network." The flexible line, which has been running for a few days, should become profitable in three years. It is now running 10 hours per day, and the people in charge admit that they would like to subcontract for parts, so that it could run two 8-hour shifts.

Material savings could amount to 3 to 4 percent, and productivity is improved by 20 to 50 percent on 3 typical parts, not to mention the reduction of processing times and inventories and the simplification of manufacturing procedures. Already, engineering and procedure departments are beginning to design products with the potential of this new line in mind.

9294

CSO: 3698/559

FACTORY AUTOMATION

SWEDEN: OPTICAL FIBER CARRIES LASER POWER FOR WELDING

Stockholm NY TEKNIK in Swedish 26 Apr 84 p 38

[Article by Jan Segerfeldt]

[Text] Goteborg--The use of fiber optics is not limited to telecommunications and industrial control systems. This was demonstrated at Chalmers Institute, where researchers have welded with laser light in an ordinary fiber cable.

"We got the idea from a West German newspaper," said Kennet Vilhelmson. "The paper described how an operation was conducted with a laser beam that was used as a surgical instrument. The physician used an optical fiber to get his 'laser knife' where he needed it in the patient,"

"That was the first time we saw an optical fiber used to transfer power rather than information which, as we know, is the primary task of fiber optics," Kennet Vilhelmson continued.

"Our experiments show that the fibers are capable of handling the laser light that is needed for microtreatment of materials. I am speaking here of ordinary, commercially available standard fibers for information transfer."

Flexible Use

These results open up numerous possibilities for the flexible use of laser beams. Instead of requiring straight lines and the use of mirrors to get the light where you need it, you can conduct the radiation in "flexible tubes."

"One possible system would employ a centrally located laser, with light transmitted to various work stations," Kennet Vilhelmson explained.

Since each station requires light only for a relatively short time, several stations could "share" the light from one laser. This would be a kind of laser "time-sharing" system, to borrow an analogy from data processing. The light could be distributed to the various stations by using electrooptical or acoustooptical "switches."

Fiber Transmission

For 3 years now, Kennet Vilhelmson and his colleagues has studied the possibility of using fibers to transfer power.

How much power can an optical fiber withstand? How much can it withstand over a long period of time? These are the basic questions that have been answered by their research.

"Were were able to transfer enough power to weld a 1-mm thick steel plate," Kennet Vilhelmson said.

The fibers may be 50 to 100 meters long without too great a loss in light quality. The courser the fiber, the greater its efficiency will be, since this makes the power density lower, thus reducing damage to the fiber. On the other hand, a thin cable provides a fine focusing quality.

The wavelength of the light should be about 1 μm , i.e. about the wavelength of light from a Nd-YAG laser. The wavelength of light from CO_2 lasers (10.6 μm) is such that the glass fibers absorb too much light and they melt. Research is underway, however, to produce fibers of materials other than glass, with less absorption.

9336

CSO: 3698/566

MICROELECTRONICS

DENMARK STARTS 4-YEAR MICROELECTRONICS PROGRAM

Helsinki FORUM in Swedish 13 Jun 84 p 32

[Article by Sigyn Alenius]

[Text] Europe needs industrial innovation to prevent Japan and the United States from taking total control of industrial development. In the future, industrial production will be controlled by microprocessors. In just 12 to 15 years, the industry that produces processors will be the leading industry in the world.

This was decided by the EC, which is launching a program that will cost billions. The goal is to promote joint European research and development. The program is called ESPRIT. "This is fine, but not enough," said Danish Industry Minister Ib Stetter. He has initiated a national Danish project of his own that will cost 1.5 billion Danish kroner. It will provide the needed impetus for research, new ideas, and the actual work. The entire project is aimed at information and microelectronics.

Not For Ailing Companies

"The Danish project will not cover the deficits of ailing companies or provide government funding for the operating costs of companies, according to the Swedish model," said Stetter. This has never been done in Denmark, where government subsidies always have been as limited as possible. Most government subsidies in Denmark have been used to reduce interest costs, especially in the case of the shipyards. Shipbuilding is the industry that must face the stiffest competition--highly subsidized shipyards abroad. In addition, some state funds have been invested in recent years to support technological research and various export initiatives. These sums have been modest, however, and the fundamental aversion toward subsidies remains strong.

The present plan involves no major financing projects. The money in Stetter's 1.5 billion kroner project will be distributed over a 4-year period. The government funds will provide about one fifth of the capital required--it will be a kind of catalyst to trigger investments in the field of technology.

The principle is at least as important as the money. Whatever the government believes it can invest will be channeled not toward interest costs, but toward

research and development. Undoubtedly, this is where the industry minister sees the greatest challenge at the present time. In addition, interest costs are not now a burning issue, since interest rates have dropped from 22 percent in 1982 when the nonsocialist government took power to the present level of 14 percent.

The government's stimulus program has the following five main points: application of information technology to the production process itself--one possible form of state support in this area is assistance in starting pilot projects; integration of information technology in the produced goods--the government is primarily interested in the development of equipment and systems for the so-called broadband network that is being planned, i.e. an information network that eventually will cover the entire country; support for the import of know-how; improvements in information technology hardware available at Danish institutes of higher learning; analysis of the overall effects of new technology on society.

Aid To Small And Medium Companies

Danish industry is behind the project. To industry, it is not just a question of a welcome influx of capital. Properly utilized, this stimulus could also lead to the export of the products that result from the project. In addition, an increased understanding of process control will result in increased industrial flexibility, which is always useful, and in better utilization of our resources.

"Of course, the sums involved in this project are not enormous, but the program is designed to provide vital assistance to small and medium-sized companies, which comprise the majority of industrial firms in Denmark," said Federation of Danish Industries chairman Nils Wilhjelm. He added that the government must continue its efforts to keep wages down, reduce the budget deficit, and combat inflation. These are decisive factors in the effort to maintain Denmark's competitive strength. If this program is successful, it will mean increased exports and new jobs. Labor supports the project for these same reasons.

This Danish program goes hand in hand with the European ESPRIT project. The five target areas of the ESPRIT project are microelectronics, program technology, advanced information processing, office systems, and computer-integrated production.

During its first phase, the ESPRIT program will distribute 750 million ECU. If this effort has the desired effects, the program will be extended for another 5 years. In order to receive ESPRIT funding, a project must include at least two EC countries--preferably more. Funding will be provided only for industrial firms. The EC share is not to exceed 50 percent of the total cost, while the company itself must provide at least 10 percent. In certain cases however, such as in small projects, the share covered by EC funds may be increased to 70 percent.

Denmark will receive an estimated 300 million Danish kroner. This sum is not crucial, but it is certainly welcome.

MICROELECTRONICS

FRENCH CNET AIMS AT COMMERCIAL SUBMICRON TECHNOLOGIES BY 1986

Paris ELECTRONIQUE ACTUALITES in French 13 Apr 84 p 13

[Article by FG]

[Text] As described in the progress report of CNET (National Center for Telecommunications Studies) Meylan (Centre Norbert Segard--CNS), the major objective in this organization's guideline plan for 1983-1986, adopted at the end of last April, is to complete by the end of this period, the development of a technology transferrable to industry, that would make it possible to produce the circuits which telecommunications will need before the end of the decade.

It is probable that if CNS succeeds in meeting its objectives (it appears to be well on its way according to its progress report for the past year), the problem of transfer to industry will remain the major stumbling block in this program.

The telecommunications technology being developed by CNS will of course have to be at the highest international level at all times, in order to allow the fabrication of circuits competitive with those made by the Americans and the Japanese, who are far from standing still. It should include some rapid logic CMOS with submicron channel length, some analog capacitor switched CMOS, and some bipolars for input/output. To validate this technology, CNET in agreement with the manufacturers involved, has selected a decoding circuit (CNA--digital to analog converter) for digital videocommunications terminals.

CNET Meylan has also adopted an intermediate objective, the development by the end of this year, of a 1.5-micron CMOS line, which will be validated by the production of a 32 x 32 switching matrix operating at more than 34 Mbits/s, and integrating about 17,000 transistors, or of a 16 x 16 matrix at more than 108 Mbits/s, for videocommunication applications. The final selection of the validation circuit should be made at the beginning of this year.

CNS should also devote part of its activities (on the order of 30 percent) to the preparation of post-1986 technologies, and to specific projects with precise goals (such as the development of machines for the IC--integrated circuit industry, an activity in which it has been rather successful until now).

The adoption of the guideline plan mentioned above, with precise objectives and compulsory deadlines, has forced CNS to make choices and reduce or eliminate some promising activities (the 1983 progress report does not say which). It has also modified its organization, through actions characterized essentially by the creation of a horizontal coordination structure to focus all the activities of the various technical divisions on the 1984 and 1986 objectives. Considering the attention that will have to be devoted in the future to industrial transfer problems, CNET Meylan has also created an Industrial Transfer Public Relations and Information Department, whose principal objective is to define a strategy in this area. While spectacular results have been obtained in IC fabrication machines, the transfer of a complete technology to a manufacturer remains an open question.

Lastly, the intermediate term is also well on its way at CNS, with the construction of the second stage expected to begin in autumn, and the guideline plan for 1985-1986 currently being prepared for adoption at the end of the year.

In CMOS, the intermediate technology which is to serve as basis for the CMOS-T (optimized for telecommunications) technology at the end of 1986, will have the following characteristics: 1.5 micron gate length; type N shallow package; one gate level of low resistance silicate, and one aluminum metal level. According to the report, activities associated with this project have proceeded on schedule, and the major results obtained are: final development of the 2.7-micron CMOS technology, with production of a first 2 x 8 switching matrix operating at a typical 70 Mbits/s; design of six different matrices toward the ultimate goal of fabricating a 16 x 16 matrix operating at more than 108 Mbits/s (or 32 x 32 at more than 34 Mbits/s); development of 1:1 projection lithography to 2 microns; metrology improvements in the 1-2 micron range; study of thin oxides (25 nm) as well as production and etching of WSi₂ deposits.

In technology, CMOS-T will adopt the general framework of the 1.5- micron CMOS with improvements seeking smaller dimensions, the addition of an intermediate level of metallic interconnections to form capacitors for analog functions, planarity, and so on.

The validation circuit selected for this technology, and which will therefore have to be produced before the end of 1986, is a video decoder integrating three converters on the same chip, to allow the eventual integration of the Y, DR, DB matrix to R, V, B on the latter, as well as the associated digital filters.

Here again, first results appear satisfactory and according to program. Such for instance, are the production of 2 to 0.2 micron MOS gate transistors; the development of analytic models of MOS transistors enhanced in the same range of gate length; and the development of a mixed masking process (electronic and optical) for inversion of masking type, as well as masking against reactive ionic etching.

All these results lead CNET to state that the development programs for CMOS-1.5 and CMOS-T have moved slightly ahead of schedule, and to view the future with a reasonable but real optimism. The industrial transfer problem will remain to be solved at the end of 1986.

11,023

CSO: 3698/573

MICROELECTRONICS

THOMSON SEMICONDUCTEURS CREATES MILITARY DIVISION

Paris ELECTRONIQUE ACTUALITES in French 20 Apr 84 p 20

[Article by JPDM]

[Text] Thomson Semiconducteurs has added to its MOS, bipolar, discrete, and special circuit divisions, a Military and Space Division (DMS) which will combine all the activities in these areas at a single location, the present Thomson Semiconducteurs plant in St-Egreve.

This division will be a profit and loss center, and will be responsible for its own strategy, standardization problems, supervision of military and space programs, and continuity in all relations with customers. But like the other divisions, it will rely on the research of Thomson Semiconducteurs and on its sales network. DMS' objective is very ambitious, since it aims to increase its share in the revenue of Thomson Semiconducteurs from the present 10 percent to 15 percent for the intermediate term, and to maintain this share despite the very high growth rate of the group (which should bring it to about 10 billion francs in 1990).

Specific Problems

Unlike such markets as computers, telecommunications, consumer goods, and so on, the military and space markets demand very special components: specific packages, burn-in, operation between -55 and +125 degrees C, very small lots, secrecy, and at times, hardening against nuclear electromagnetic pulses.

But experience has shown that their production fits poorly in the manufacturing programs of mass produced semiconductors, especially during periods of high demand such as we are currently experiencing; the gathering of specialized groups with their own organization in one location proved necessary. DMS' goal is to meet this need: 120 employees on 3000 sq-meters will work on marketing, the diffusion of circuits that require very specific technologies (hardened circuits), assembly, testing, burn-in, and general quality in this area. All the circuits will be obtained exclusively from Thomson Semiconducteurs in the form of diffused wafers, whether they be MOS, bipolars, gate arrays, preprocessed, or even beginning in 1985, discrete circuits.

This division will have its own design facilities for custom circuits that cannot be produced in semi-standard models. Some circuits will even be designed for technologies whose use in production is only being planned: at the time they are sold, these circuits will thus be at the leading edge of technology.

DMS is not a new investment, since it combines activities that had until now been disseminated among various divisions. Nevertheless, investments in each field will continue as started, particularly for the two current major programs in the military field, namely the TGV IC program, which will cover the 1984-1987 period (and which should be officially announced after we go to press), and a hardened circuit program (with SOS technology among other things, even though Thomson-CSF is providing no details on this subject). DMS will not be responsible for Thomson-CSF's GaAs IC activity, but close technical contacts exist with the microwave circuits division, as well as with the leaders of the MOS and bipolar divisions, to define the technologies that will be industrialized in the future.

Exportation Effort

Even though DMS' priority is the French market, an effort will be made to export through the sales network of Thomson Semiconducteurs: on a world market of 18 billion dollars, the military represents 8-9 percent (with a strong "protected" share). In this area, the French market represents 34 percent of the European market. The military and space semiconductors line of Thomson Semiconducteurs appears to be very full: its strong points are 4-bit microprocessors, PROMs, a 16 x 16 multiplier, 8 and 16-bit microprocessors (a military version of a 12.5 MHz 68000 will be offered this year), MOS memories, semi-standard MOS and bipolars, and later, discrete devices.

11,023
CSO: 3698/573

SCIENTIFIC AND INDUSTRIAL POLICY

CURIEN NAMED FRENCH MINISTER OF RESEARCH, TECHNOLOGY

New Minister's Background

Paris AFP SCIENCES in French 19 Jul 84 p 1

[Text] Paris--On 19 July Hubert Curien was named minister of Research and Technology in the new French government of Laurent Fabius. Mr Curien is a scientist and an academic who, for more than 10 years, as president of the CNES [National Center for Space Studies], has been one of the principal leaders in French space.

His was an important role in the decisions taken just a few weeks ago by the minister to whom he was responsible, Mr Fabius, who was then in charge of industry and research, and by the government to give new elan to the Ariane program, with the objective of making it a launcher capable of launching European mini-shuttles.

As chairman of the Council of the European Space Agency (ESA) until the end of last month, he was also able to convince the other members of that agency to "Europeanize" that program, thus giving Europe the means to guard its position between the big two of space, the United States and the USSR.

This Vosgian, born in Cornimont on 30 October 1924, a student and a teacher of physics, is very familiar with the problems connected with the latest research and technology. For more than 20 years he has occupied, successively, posts of increasing importance in that field. That was how it happened that in October 1969 he became general director of the CNRS [National Center for Scientific Research] and 4 years later, in July 1973, under Pompidou, he was appointed to the General Delegation for Scientific and Technical Research (DGRST), a post in which he had to coordinate all French research and, in particular, to intervene in the fields where a special effort is required.

On 3 July 1976, under the presidency of Valery Giscard d'Estaing, Mr Curien became the president of the CNES. In that post he was able to maintain close cooperation with both the Americans and the Soviets (the first French astronauts' flight took place in 1982).

Despite his duties related to being responsible for and organizing research, Hubert Curien has always cared about teaching his course in crystallography and mineralogy at the Faculty of Science in Paris, so as not to lose his ties with teaching.

Quite slender, with graying hair, very affable, Mr Curien is all the more well known in national and international scientific circles because he is a member or the president of 30 scholarly societies, in particular: the European Science Foundation in Strasbourg, the Palace of Discovery, etc. He has never paraded any personal political opinion.

Personnel Changes, Policy Outline

Paris AFP SCIENCES in French 26 Jul 84 pp 2-3

[Text] Paris--The transfer of power between Laurent Fabius on the one hand and Mme Edith Cresson, Hubert Curien and Martin Malvy on the other hand, took place on Monday 23 July at the Ministry of Industry, clearly in a good mood, with the prime minister even going so far as to imitate the Corsican accent.

Mr Fabius explained that on Sunday at midnight he had personally telephoned Mr Malvy, who was vacationing in Corsica. The hotel porter, whom he awakened, knocked on the door of the future secretary of state for Energy (who is replacing Jean Auroux) and asked, "Is it plausible that you are being called by the prime minister?" The story was told by Mr Fabius in an imitation of the Ile de Beaute accent.

Mr Fabius, beaming despite his "regrets" at leaving the Ministry of Industry and Research, said he hoped that despite the separation between Research and Industry, the two ministries will continue to work "in close agreement."

Calling Mme Cresson a "fighter", he stressed the interest in the rapprochement between Industry and Foreign Trade which, according to him, "has already been in effect for some time." In particular, he asked the new minister of Industrial Redeployment to watch "very closely" over the regions, Lorraine in particular.

For her part, Mme Cresson emphasized that "France is a country that opens onto the world" and said she believes that "many challenges will find international solutions." Bringing the ministries of Industry and Foreign Trade closer together has been called "the Japanese approach," she added, but "many countries have already adopted it."

The only holdover from Laurent Fabius' team at Industry, Louis Mexandeau, who is in charge of PTT [Post and Telecommunications], got some comments from the new prime minister. "I learned to work with the PTT, which wasn't always easy because they are more powerful than Industry, Mr Fabius remarked. "I hope Mme Cresson will be able to do what I couldn't do: reestablish the balance between the two ministries.

Saying he believed his appointment was perceived as "homage to the whole" of the scientific community and a sign that priority will be given to research, Mr Curien briefly traced the broad outlines of his plan of action for the near future. They concern the status of scientific personnel and the putting in place of structures for "questions that have arrived at maturity."

"A follow-up to the Scientific Orientation and Programming Law (LOP)," and the minister is going to follow the matter closely.

Mr Curien was careful to assure the numerous officials of research organizations who were present at the ceremony of the transfer of power that he would leave the full responsibility to them, and that there would be no needless interference in their affairs on the part of the ministry.

He asserted that Industry should do "more research" but that it would have to be wary of a coercive approach: "Industrialists must be convinced that without research they will languish." He said he believed that "the ball must be thrown even farther" as far as scientific Europe is concerned, and he added that France, because of its geographic position, could be "the link between all of the scientific worlds."

Mr Curien ended his speech with this sally: "Some people have called me a Fabiusian. That suits me." To which the prime minister retorted that he had been a "Curienist" since he attended an Ariane launching in Kourou.

Brief Interview

Paris AFP-AUTO in French 20 Jul 84 AFP 201103 Jul 84

[Interview with Hubert Curien, the new minister of Research and Technology, in Paris, 20 July 1984; name of interviewer not provided]

[Text] Paris, 20 July (AFP)--"The fact that a scientist has been called upon for the Research and Technology Ministry is one more proof, if one were needed, that research remains one of the government's priorities," the new holder of that portfolio, Professor Hubert Curien, told the AFP.

[Question] You are the only minister without a political label in the new government. How do you explain that?

[Answer] It's true I don't have a political career. I am a scientist by training and taste, but one who has always been interested in the problems connected with organizing research and the latest technology. The prime minister's choice has to be seen as the desire to call upon the different skills."

[Question] To be precise, you are the minister of Research and Technology, but it is Mme Edith Cresson who is responsible in particular for industrial redeployment. Industry has been separated from research. How do you look at things?

[Answer] Mme Cresson and I, if I may say so, are the "continuator" of that entity that was the Industry and Research Ministry. I am sure there will be no difficulty in sharing jurisdictions. The ministry that I am directing is a full-fledged ministry that is responsible for supervising the various research organizations. In particular, my role will be to define and provide the broad orientations of scientific and technologic policy.

Hubert Curien, for whom a successor will have to be found quickly to fill the presidency of the CNES, which he has directed for over 10 years, intends to leave the "broadest responsibility" to the numerous research organizations he supervises. But he is the one who will have to decide on the credits for those organizations, because the overall research budgetary envelope depends on him.

Statements in LE MONDE

Paris LE MONDE in French 5/6 Aug 84 p 7

[Article by Maurice Arvonny and Elisabeth Gordon: "'We Must now Let the Laboratories Work Together', Says Hubert Curien, the New Research and Technology Minister"]

[Text] The new minister of Research and Technology, Hubert Curien, is settling into the still-not-completely-finished offices of the former Polytechnic School, or more precisely the premises which for generations of pupils was "the general's apartment." His new office has not changed the man, who is still courteous, precise--and candid: "I won't talk to you today about industrial research," he said at the outset. "It is one of the main sections of my future actions, but I am just starting to study the records. When vacation is over, I will see it more clearly."

Exit thus, by the main door too, the theme of industrial modernization. He will occasionally point out the window during the interview that follows, but the minister wants to stick to the subjects he already knows well. He knows a lot about them.

For the very short term, the minister's program is a simple one: the budget and the status of personnel. Concerning the budget, "the procedure is under way, but the figures are not yet definitive." "The prime minister has announced that research will be clearly favored," Mr Curien reminds us, also emphasizing that there will be posts created for research, whereas the current payroll will be strictly retained in many other sectors. As far as status is concerned, much progress has been made. Many talks with unions have already taken place. A review of all the points of discussion will be made quickly, followed in September by a final round, and these matters should be settled quickly, which is what all parties hope for.

"Fewer Commissions"

What, then, will the new minister's lines of action be? It seems to him to be important first of all to clarify "what policies can be conducted vis-a-vis researchers." "It is important that there be an Industry and Technology Ministry that is not connected with any other ministry," not in order to create a caesura between research and industry, but because "research and technology are linked with all the activity sectors: industry, but also agriculture, urbanism, the medical sector, university teaching." The ministry is to provide these connections.

On the other hand, "it has to be a ministry of policy and not of management. Management is the business of the organisms, and the ministry doesn't have to watch over it in a finicky way, nor does it have to directly administer the important budgets. The ministry must define a policy and make sure--I insist on this--that the organisms work together and in liaison with the industrial and economic partners." Mr Curien is therefore hoping for "a decrease in the number of commissions." Of course, evaluations are necessary, but there is no point in multiplying the administrative organizations. "We have even more actors than we

have judges," he says. Once the research policy has been defined, "people must be left to do their work and periodic meetings must be arranged, to see what has been done and, possibly, to ask them to make changes."

One consequence: the incentive credits from the Research Fund which the ministry has at its disposal will be the object of a "recentering." Principally, they are to make possible preliminary studies before starting potential new programs.

In line with the mission he was explicitly given by the prime minister, Mr Curien is also going to consider "a policy for long-term personnel, in cooperation with the research organisms and the manufacturers." This is a question he has concerned himself with for 10 years*, and he is very familiar with the problems involved. The irregularity in recruitment has made of the number-of-employees curves "camels and dromedaries. We have to get away from this and, for all that, draw up a 15-year employment policy. This isn't easy, but it's a necessity," says Mr Curien, who knows he can count on help from Laurent Fabius in setting up such a policy. "For researchers, the next creation of jobs will make it possible to start correcting the curves. For technicians, the major need is for an adjustment of categories and flexibility in promotions."

Another of the minister's preoccupations: the data processing equipment in the laboratories, which is inadequate, partly for budgetary reasons and partly for reasons of industrial policy. "This is a very urgent problem, for several years we have had unacceptable delays. We must protect our national industry, but we must also protect our national research," Mr Curien states.

European Networks

A few weeks ago Hubert Curien was presiding over the ESA. He still presides today over European Science Foundation. That shows what an expert he is on the subject of scientific Europe. He confirms that a strong impetus was provided by Mr Fabius when he was chairman of the Council of Research Ministers of the EEC. Another impetus should come from the meeting of science ministers of the Council of Europe next September. Mr Curien would like to see progress made in building "networks" that would group together laboratories working on related projects. If a laboratory is judged suitable to become part of a network, the administrative authority to which it is responsible would grant some supplementary financial means, but above all it would facilitate insofar as possible the researchers' moves from one laboratory to another, for long-term missions or for training activities.

Training is a field to which Mr Curien attaches great importance. "In full agreement with the minister of National Education, we must act in such a way that training proposed for young people suits the needs of our research institutions and our industry." As far as the granting of research scholarships is

* Mr Curien was general director of the CNRS from 1968 to 1973 and then a member of the DGRST from 1973 to 1976.

concerned, "We must not create just a single mold, which would have the disadvantage of taking the responsibility away from the authorities who dispense these scholarships. Those authorities must watch over the future hiring of the young scholarship holders. I should like my academic colleagues to have all of that feeling of responsibility when they assign scholarships for graduate school." In fact, one can be an excellent professor and teacher of disciplines with uncertain prospects. But should a line be drawn, for all that, on these subjects? That is not the new minister's intention: "We need brilliant students in the most widely-varied sectors, but it is also necessary that a large number of students find jobs and become a part of the nation's industrial activity."

Industrial activity is in fact the stake, the principal future of young people trained for research. Mr Curien also recommends that the students be encouraged, even more than they have been in the past, to prepare their theses in industry. "This will require a greater openness on the part of our colleagues in graduate education and in research; this will also require that customs be somewhat softened in favor of more modern behavior."

A Veritable Underground

A minister of Research and Technology cannot disregard industrial reality, whether it be a matter of training or of contacts between science and industry, at the national as well as at the regional level. As far as the latter is concerned, Mr Curien emphasizes the existence of a problem that is "important, but difficult to settle." "Deconcentration is a necessity; it also calls for coordination. I find that in the regions, businesses have a number of people I can talk to. So many extremely skilled ambassadors, but we have to avoid stepping on their toes," the minister says. He hopes "to avoid the multiplication of parallel authorities, a veritable underground in the eyes of small businesses."

There one finds the constant concern that motivates Mr Curien, as well as his sense of humor when he emphasizes that "the machinery itself must not consume an important share of the vital strength. The small and medium-size business of course have their future before them, but the sooner they attain it, the more satisfied they will be.

8946

CSO: 3698/585

SCIENTIFIC AND INDUSTRIAL POLICY

JEUMONT-SCHNEIDER TAKES STOCK OF PRODUCTS, FINANCES

Paris L'USINE NOUVELLE in French 28 Jun 84 p 30

[Article by Philippe Douroux: "Jeumont-Schneider Marks Time"]

[Text] Jeumont-Schneider has successfully undertaken a shift from electromechanics to electronics, and has emerged as the leader in the private telephone industry. Nevertheless, there are some signs of an ebb, particularly in traditional sectors where there has been a decrease in large contracts.

Jeumont-Schneider, the model student, has joined the ranks. With a net profit of 78.3 million francs, 1983 remains respectable. But compared to 1982--101.6 million francs--it is a sharp setback. The figures for the parent company speak even more clearly: net profits of 25.6 million in 1983 compared to 50.3 million the previous year. "And 1984 will hardly be any better," observes the company management. JS, which has had five exemplary years, has become used to seeing its profitability improve, a sign of its industrial mobility. Net profit in 1982 of 101.6 million francs was a record.

The Office Automation Puzzle Takes Shape

While modest at the international level, these figures allow JS to anticipate the future serenely. Electronics is replacing electromechanics, and JS is emerging as the leader in the private telephone industry ahead of CIT and Thompson, with 35 percent of the market. JS is making inroads in the office market. The office automation puzzle is taking shape with Cerci (computerized engineering), which regained its financial balance in 1982, and Secre (word processing, peripheral telephone devices). The Sicob 84 gathering will tell more; perhaps a good forum for the last act: electronic writing.

In 1984, however, the industry has revealed certain signs of a slowdown; the traditional sectors. Energy, the naval industry, and railroad construction, which used to finance JS' efforts in office automation, now threaten to hinder it.

In 1982 office automation and electronics made up 18 percent of JS' operations. In 1983, the decline in the energy and naval sectors pushed this

portion up to 28 percent. But for the most part--72 percent of the 1983 revenue--JS is still in the more precarious sectors.

Large contracts in the area of electrical energy production and distribution are becoming more rare and financing for important projects is too often an obstacle for French companies. Brissonneau and Lotz Marine, shaken by both the crisis in offshore drilling and naval production, have moved from recovery to restructuring. As for the railroad industry, international competition is increasing in intensity.

To confront these problems Christian Devin, JS' President and CEO, has proposed reorganizing all of Empain-Schneider's railroad activities under a new JS subsidiary, Schneider-Jeumont Rail. The new company, better adapted to market conditions than a GIE [economic interest group], should be set up during the first half of 1984. But the "barons" have not yet had their last say, and they oppose any drastic reorganization. As a result, everything is presently on hold because of the situation at Creusot-Loire, key JS subsidiary.

But the first obstacle to be overcome in the campaign to be the premier office automation force in the Hexagon will undoubtedly be internal. For now, JS' export efforts are directed primarily toward the Southern Hemisphere. In fact, Latin America absorbs over 40 percent of JS' exports, while North America fails to surpass 2 percent. As a direct consequence of the indebtedness of the developing nations, the company's exports dropped from 2.1 million francs in 1982 to 1.6 million in 1983.

"1984 will be the year of truth with respect to the bets we made for the past three years," said Christian Devin a short while ago. For Devin, JS' effort in office automation, and especially in power electronics, should allow the company to catch a second wind.

12686
CSO: 3698/511

SCIENTIFIC AND INDUSTRIAL POLICY

SWISS INTRODUCE TAX BREAKS, INSURANCE FOR INNOVATORS

Bern TECHNISCHE RUNDSCHAU in German 17 Jul 84 p 23

[Article by Alois Altenweger: "Fledged, But Hardly Airworthy"]

[Text] Under the concept of "innovation risk guarantee," the Council of Estates has adopted a new variation of re-insurance (for money donors) and tax breaks (for borrowers). It is pretty certain that the National Council will follow it in this undertaking. The most important objections to the IRG [innovation risk guarantee] are to be described in the first part of the article, while the possible supplementations on the occasion of an anticipated revision are pointed out in a second part. We base our remarks here on considerations that were entertained by H. Landert in the August 1984 issue of HELVETOEC-INFORMATION.

The innovation risk guarantee, on the one hand, is to help those who provide risk money [venture capital] in absorbing losses during innovation financing through re-insurance and, on the other hand, by means of tax breaks, to encourage the small and medium enterprises to take more innovation risks. The criticism from practical operators in the economy is, to begin with, aimed at three points: First of all, it is denied that there is not enough venture capital available. Besides, the assumption is rejected to the effect that so-called investment gaps are a general phenomenon in the Swiss economy. Dr Leonhard Gysin, chairman of the board of directors of Agie, Losone, points out that "It is above all the big firms which have missed the bus regarding their future and which reveal an urgent need for catching up" (NZZ [NEUE ZUERCHER ZEITUNG], No 127, 1984). But it is especially the big firms which do not get any benefit from the performances offered by the innovation risk guarantee.

Second, the IRG is designed to put the more innovation-ready enterprises-- which already have employed their own money without the safety net provided by the federal government--at a disadvantage in that the lazier competition is now being helped in getting to its feet. "Anybody who runs to the government will get tax breaks. Anybody who fights for himself will wind up with the short end of the stick" (Professor Willi Linder, NZZ, No 90, 1984).

The third objection, which is both of a practical-functional and a fundamental nature, concerns the manner in which enterprises would qualify for the

IRG. The bill calls for the documentation of "real market opportunities"; this documentation is to be submitted to a commission of experts. But this boils down to a striptease of business secrets because genuine innovation can be judged only by an expert drawn from the competition.

Finally it is also pointed out that even the best innovative achievement does not sell itself but that market opportunities must be activated for this purpose. This depends to a much greater degree on the business operator's marketing than on the innovation content of the product. "Every innovation is dead if nobody buys it" (H. Landert, Buelach).

Supplementary Measures Necessary

The second element in innovation promotion, which deserves that name, would--in addition to government encouragement which is confined to a rather modest 100 million Swiss francs--be the rather noticeable availability of private venture capital in those places where capital is needed, in other words, in the enterprises.

Here we might mention first of all the formation of "innovation reserves," similar to the labor procurement reserves. The essential point here is that, at the moment at which these reserves are used, the taxes paid on that would be refunded. It is now being assumed, not without justification, that "The tax advantages contained in an innovation reserve would also actually be claimed." Here it would also be necessary to look into the possibility of having private individuals acquire tax-favored "innovation certificates" from individual enterprises. Finally, one might also think in terms of being able to use the innovation reserves also for the additional purchase of new methods, techniques, and components, be it for complete takeover or for licensed use.

Innovation however does not only mean pushing an invention all the way to the prototype but also implies successful introduction on the market. Here one would likewise have to use the funds made available for the entire marketing sector (for example, the systematic work on export markets).

The measures outlined here have the advantage that the funds needed can be earned by the business operator, that their use is up to the business operator, and that the entire innovative arrangement remains within the business operator's responsibility. In this sense one can only hope that, after the dust has settled from the prestige fight between the individual opponents of the IRG and the Confederation Council, a way will be found to the meaningful supplementation of the law.

5058
CSO: 3698/584

SCIENTIFIC AND INDUSTRIAL POLICY

FRG SUPPORT OF 'MANUFACTURING TECHNOLOGIES' R&D OUTLINED

Wuerzburg CAE MANAGEMENT in German Jun 84 p 30

[Article by Dr Jochen Hiebel: "Forty Percent from Bonn"]

[Text] The future of a high-wage-income industrial nation is closely tied to modern, efficient production technologies. The governments of the industrial countries support the introduction of new techniques because they are very much concerned with the competitiveness of their economies. The West German government is also helping domestic industry: The Federal Ministry of Research and Technology has a budget of DM530 million available for research and technology over a period of 4 years. In addition to the development of robots, the integration of CAD/CAM systems in terms of enterprise operations is a main point in the program which has been allocated an amount of DM350 million.

The Karlsruhe nuclear research center was given the task of carrying the program out by the federal government. A simplified method is to be used in speeding up the use of data processing in enterprises for computer-assisted development work, designing, and production, and the development of modern handling equipment is to be supported on a broad scale. The goal of this promotion effort is to help the producers of production-engineering capital goods, as well as to improve their output and their products with the help of modern data processing techniques. As the suppliers of equipment, enterprises in the production-engineering industry perform a key function for the FRG in two different ways: First of all, they supply the domestic market with efficient machines and, then, they contribute considerably to the improvement of the performance results through a high export rate.

Greyhound Method

Support is being given to enterprises in the capital-goods-producing industry with home offices in the FRG which develop, produce, and sell production-engineering equipment. The subsidy for individual projects comes to 40 percent of the chargeable costs although, for each enterprise, the amount only comes to a maximum of DM400,000 for the program running time in the case of CAD/CAM introduction or DM800,000 for the development of robots. One and the same enterprise however cannot be promoted in both sectors. Chargeable costs

are expenditures for personnel, development subcontracts, consultant services, and training by third parties, as well as project-related procurement. The method is simplified with the help of predetermined lump-sum personnel cost rates.

Applications are being processed in the sequence in which they are received. It has been indicated both by the Federal Research Ministry and, on the other hand, by the Karlsruhe nuclear research center, that the money would presumably be sufficient for all those who want to get this kind of help; nevertheless, filing applications at the right time is important already because these applications are being processed in the order in which they were received.

Help from Consultants

All enterprises in the capital goods industry, which develop and make machines and complex components for the processing industry, are urged to participate in working out realistic designs and concepts for computer-assisted production techniques. But there must be a technological minimum level to document the enterprise's support worthiness because the benefit to society as a whole is heavily emphasized in this promotion effort.

This is why especially medium-level enterprises with a far-ranging outlook, but without possibilities in terms of personnel for project processing and fund procurement, should seek to cooperate with specialized consultants. Through expert application preparation, their experience helps in working out justified requests for project support. The service offered by quite a few consultant enterprises goes far beyond the application-filing stage. They handle measures that are necessary for specific promotion purposes during project execution, such as negotiations in case of changes, justification in case of cost shifts, documentation, as well as interim and final reports.

In this complex package of tasks, the inclusion of outside consultants sees to the goal-oriented implementation of all necessary individual tasks. Of course, the enterprise that looks for consultant services should, in searching for a consultant partnership, see to it that the consultant's experience potential agrees with the magnitude of the project.

5058
CSO: 3698/580

SCIENTIFIC AND INDUSTRIAL POLICY

BRIEFS

FRG VENTURE CAPITAL PLENTIFUL--The first venture capital fund of the TVM Techno Venture Management Company was completed after the subscription of DM116 million with DM16 million above the target figure. Techno Venture was founded in October 1983. In addition to the founding investors Siemens AG [Incorporated] and Deutsche Bank AG, another seven industrial firms and one foundation will make the partnership capital available. As its next step, the Techno Venture Management Company--in which Siemens, the Matuschka Group, and TA Associates are participating--is preparing the founding of another fund, the "Techno Venture International" Fund. It is to have assets of about DM30 million. Through participation in this fund, foreign industrial firms and financing institutions will get an opportunity to become involved with young German enterprises. Out of the total investment volume in both Techno Venture funds, amounting to almost DM150 million, about DM90 million are to be available for investments in Germany. In Germany, Techno Venture has already participated in three enterprises which are active in the fields of materials testing, chip function testing, and software production. [Text] [Duesseldorf HANDELSBLATT in German 22 Jun 84 p 2] 5058

CSO: 3698/580

TECHNOLOGY TRANSFER

INCREASE IN INDUSTRIAL ESPIONAGE REPORTED IN SWEDEN

Stockholm SVENSKA DAGBLADET in Swedish 23 Jul 84 p 1

[Article by Bertil Ekerlid]

[Text] Industrial espionage in Sweden has increased dramatically since the late 1970's. Industry observers told SVENSKA DAGBLADET that this was because the Eastern countries have been cut off from Western exports since the invasion of Afghanistan and because they believe it is easier to steal secrets here than in the United States or Japan.

"There is a tremendous amount of industrial secrets being stolen," said Commissioner Sture Høglund of SAPO (Swedish Security Police). "As far as we can tell, there has been an increase in recent years."

He pointed out, however, that the National Police Board has no reliable data, since industrial espionage was formerly considered a matter for the individual companies.

"We now see it more and more as a matter for society as a whole," he added.

According to Ilja Cordi, who worked as a consultant on the vulnerability study completed by the National Board of Economic Defense, industrial espionage is on the rise because new systems are becoming more expensive and it is taking less time to develop them.

"When it took 4 or 5 years to develop a new product, the competitors had time to catch up," he said. "But now that it takes just 18 to 24 months, knowledge of the new product has become more and more valuable."

80 Million In Damage

In today's high-tech society, it is estimated that illegal activities costing 12.3 million kronor may yield information worth 750 million kronor in return. It is believed that, during the 1970's, American industry lost 80 million kronor as a result of industrial theft.

"New technology also provides additional opportunities," Ilja Cordi pointed out. "Sophisticated thieves can crack computer codes and gain access to information in that manner."

Obtaining information during official visits by delegations is another common method, according to Sture Høglund.

The classic method of industrial espionage involves bribing employees, however. In the late 1970's, a Swedish engineer who worked at the Rifa plant in Sundbyberg, which produces component parts, was involved in an "accident" with an "immigrant" from Eastern Europe. The Swede was compensated generously and a personal relationship developed. The "immigrant" began asking for technical literature and the names and addresses of the engineer's colleagues.

This bribery attempt was unsuccessful, however, and it is now used as a textbook example when SAPO teaches security personnel at large Swedish companies about recruitment methods used by the Eastern countries.

According to Ilja Cordi, Swedish companies have become more aware of industrial espionage in recent years.

"They have begun monitoring the movement of their own employees within the plant, for example to see if they have some reason for visiting other departments," he said.

Ilja Cordi said that the Eastern countries were not the only ones involved in espionage. Theft by other companies has also increased.

"One year ago, IBM revealed that the Japanese were systematically copying parts for their own computer production."

Director Magnus Lemmel of Ericsson's staff said that the increased activity was due to faster product development and the high technological level of new products. He is not concerned, however, that anyone will gain access to their AXE system.

"It is so complex that it would be difficult to copy even if someone obtained the design."

"Visit" Cost 100 Million

Many serious cases of industrial espionage have been revealed in recent months. In late March someone attempted to gain access to the energy-efficient technology used by LKAB (the LKAB Mining Company) at its pelletizing plant in Kiruna. Outsiders were immediately prohibited from entering the plant.

At about the same time, SAPO was informed that an SAS hangar at Arlanda Airport had been "visited" by foreign airline personnel. Saab-Scania's Fairchild project has also attracted outside attention. As a result, rigorous security regulations have been introduced.

Thieves also broke into the Telecommunications Service, where they copied software. It cost the service 5 million kronor to change the system. Work is now underway to stop the leaks. This will cost the Telecommunications Service an additional 100 million kronor.

In addition to the increased awareness on the part of companies, more vigilance is now being exercised by SAPO in the area of industrial espionage.

"It must be stopped at as early a stage as possible," said Sture Hoglund. Convincing evidence is seldom found and only minor sentences result from conviction for crimes of this type.

In addition to outright acts of espionage, there are many cases in which ideas and patents are stolen and then marketed under a different name. The Stockholm Chamber of Commerce has a special arbitration court for such cases.

"Few cases reach arbitration each year, however," said Torbjorn Spektor, a legal expert at the arbitration court. "Most of the claims are settled out of court."

Symposia On Vulnerability

The government has allocated funds to learn more about Sweden's vulnerability. The Academy of Engineering Sciences and the Academy of Military Sciences have received 1 million kronor to conduct a series of symposia on research, industry, and security policy.

Previously, the two academies produced a research report on the interrelationships of technology, industry, and defense. Now they will go a step further and develop ideas from a broader perspective on how our society could be affected, for example, by a blockade.

"There is a need to investigate the overall practical and psychological capacity of our industrial society to meet the ultimate goal of our national independence in possible crises," according to the high-flown charge to the group.

Symposia, Not Study

Instead of a traditional study, the Academy of Engineering Sciences and the Academy of Military Sciences will conduct a series of symposia, beginning this fall.

"In this way, business and government can come together and discuss which areas would be critical in a crisis situation," said Dr Ilja Cordi, project director of the vulnerability study.

The two academies believe that technical and industrial issues will take on increasing importance in the area of security policy in the coming years.

Ilja Cordi pointed out that, even though we have become more dependent on the import of electronic components, we have also become more resistant to foreign pressure, since we are now stronger in the area of research and development.

How To Secure Supply

One of the questions that will come up at the symposia is how to secure our supply of vital electronic components for data and control systems, both for industry and for the military.

The group will also set long-range goals for research and development and decide what should be done by industry and the universities and what should be done by the military.

The symposia will also discuss the possible impact on Sweden of the trend in the United States to increase restrictions on the export of components, while reducing the flow of information on advanced technology.

9336

CSO: 3698/565

TECHNOLOGY TRANSFER

FRG COMPUTER FIRM GETS VENTURE CAPITAL, STARTS BRANCH IN U.S.

Wuerzburg ELEKTRONIKPRAXIS in German May 84 p 52

[Article: "Technology Transfer in the Other Direction for a Change"]

[Text] German computer manufacturer founds a largely independent firm in the United States with venture capital support.

"The venture capital was necessary to still our enormous financial hunger," declared Rolf Gaertner, marketing manager at PCS, in reference to the financial injection of \$3.5 million which has been available to Cadmus Computer Systems since the beginning of July. The 25-percent PCS owned firm was established in March in the Lowell/Boston area. The start-up capital for the first quarter came exclusively from PCS, the name from Greek mythology. Cadmus is the brother of the goddess Europa.

By year's end \$5.5 million is expected from the venture pool, at which time the three American venture capital firms, New York City Bank, Matrix Partners and Charles River Partnership will hold 50-percent of the Cadmus shares.

Better Contact With the American Market Through Cadmus

An agreement of cooperation has been signed between PCS and Cadmus which includes a manufacturing license and the exclusive distributorship of PCS products in the United States and Canada for a period of 5 years. Also planned are know-how transfer, joint procurement of equipment and parts and second-sourcing of critical subsystems.

Cadmus will build on the QU 68000 computer system which is based on the 16/32-bit 68000 microprocessor, implements the Unix operating system and can be linked with other units via the Q-Bus system. Swift incorporation of new technologies, for instance the integration of fast ancillary computers and multiprocessing arrays, will strengthen the product line.

Via the close connection with Cadmus, PCS seeks direct access to the American software market and better contacts with the component and peripheral equipment manufacturers there. Cadmus' sales target for the first year of business is DM75 million in a worldwide market which is projected to reach about DM20 billion by the end of 1985.

9160

CSO: 3698/543

TECHNOLOGY TRANSFER

BRUSSELS NEWSPAPER COMMENTS ON TECHNOLOGY TRANSFER DILEMMA

Brussels LE SOIR in French 27 Jul 84 p 2

[Article by Pol Mathil: "The Dispute Over Technology Transfer to the East"]

[Text] General Ion Pacepa was deputy director of Romanian counterespionage until 1978. It was in 1978 that he defected to the West, but it was just recently that he was authorized to make certain revelations (we will return to these in future issues). Pacepa tells notably how, in 1978, Leonid Brezhnev invited Ceausescu to visit an ultrasecret "microelectronic city." Ceausescu, an indefatigable traveler, admitted that he had never seen such a collection of microelectronic systems. "We have several such sites," said Brezhnev. "They were installed by the KGB and the army, based exclusively on the most recent Western technological information."

Richard Perle, U.S. Under Secretary of Defense, was not invited to visit the "Red Silicon Valley," but is no less impressed by the Western technology transfer to the communist East. According to Perle, no fewer than 150 Soviet weapons systems, including even the SS-20's hanging over West Europe, use technology acquired either legally or illegally in the West. Do not overlook of course, gadgets like the "Kama" trucks in use in Afghanistan; the Lockheed C-141 cargo plane, which flew in the USSR under the name of Il-76 even before its maiden flight in the United States; or the Ryad computer, foundation of the "computerization" of the USSR, a carbon copy of the IBM series 360 and 370.... In 1978, the Russians purchased one of the world's largest floating docks. They promised that it would only be used for the merchant marine. In reality, it is now part of the Soviet Pacific fleet and receives mostly aircraft carriers....

Four Channels of Supply

There is no point in splitting hairs. Twenty thousand Soviet specialists have as their sole mission to pursue, discover and acquire Western technology by any possible means. What are these means? They have 4 channels at their disposal.

Two are legal: a) official direct purchase (i.e., Kama, dock, innumerable microelectronic acquisitions and... Pegard); b) access to open sources, research centers and universities. It was while copying an ecological survey

accessible in the public library of the state of Tennessee that the Russians got hold of the plans for an explosives factory.

There are two others, which are illegal: a) the purchase through the intermediary of a third country or of a deceitfully neutral business. Werner Bruchhausen, a citizen of the FRG, was able, thanks to a Silicon Valley-based company, to transfer to the Eastern companies microchips and the latest electronic inventions, all within 4 years.

Finally, b) espionage, on an incalculable scale. The great majority of spies imprisoned in the West or expelled, since they were covered by diplomatic immunity, were less interested in military devices than in technology. William Bell, a Hughes Aircraft Corp employee, delivered to the USSR, through a Polish spy, the plans for the F-15, among other things, and for the radar for the new B-1 bomber, etc. Thirty-five large scale spy activities have been uncovered in Silicon Valley alone.

Impossible Agreement

The technology transfer question is very complex politically and economically. Even though everyone agrees on the necessity of stopping, not trade in general, but the West's participation in the technological progress and military power buildup of the USSR; serious disagreement leads to Western inability to stand up to the immense Soviet enterprise which consists of "using the rope furnished by the West to hang it all the better."

First, especially because of commercial competition, we are unable to arrive at a consensus relative to "double use," that is to say, the line which separates nontransferable military technology from completely exportable civil technology (Pegard is a victim of this, for example). Secondly, the West, for psychological as well as commercial reasons, is not capable of defining the acceptable relationship between the commercial (but also political) profit of technology transfer and its security-level risks. The dilemma is further complicated by disparities which are not only international but by competition among companies and even among the regions of a single country.

In such conditions, any attempt at coordinated international actions is doomed to failure. No embargo has ever been seriously attempted, commercial competition and partisan interests always being stronger than any possible consciousness of collective danger. This explains why the North Atlantic Council, the parliamentary association of the NATO countries (headquartered in Brussels, but hardly known in Belgium), has just proposed the creation of a NATO agency responsible for technology transfer problems on a political and economic level more extensive than COCOM, the Control Commission based in Paris, which deals primarily with military aspects.

The total value of the technology transfer toward the East is set at about \$50 billion, which is not excessive. Its consequences are more difficult to evaluate: it is estimated that while during the sixties the gap in the microelectronic sector between the USSR and the West was from 10 to 12 years; today, as a result of transfer in all areas, it is no more than about 3 to 5 years. And that has a value much greater than \$50 billion.

TECHNOLOGY TRANSFER

BRIEFS

VW INVESTS IN YUGOSLAVIA--Wolfsburg (p)--VW will intensify its joint effort with the Yugoslavian automobile company TAS (VW participation is 49 percent) in Sarajevo. As confirmed at Wolfsburg, VW has contractually agreed in Belgrade to participate in a TAS investment amounting to--converted to German units--DM 100 million. Of the total amount, TAS will contribute DM 40 million of its own funds while the remaining DM60 million will come from Yugoslavian Staatsholding Unis (51 percent) and VW. In Wolfsburg it was further stated that this investment will create, in one area, the prerequisites for local production of the new Golf model starting in July 1985. The Golf models manufactured in Sarajevo are destined for domestic consumption only. In another area, these funds will contribute to modernizing and upgrading the facilities for manufacturing parts for VW (Golf rear axles, exhaust pipes and mufflers and wiring bundles). [Text] [Landsberg PRODUKTION in German 14 Jun 84 p 2] 9160

CSO: 3698/543

- END -