

# U.S. Coast Guard Research and Development Center

1082 Shennecossett Road, Groton, CT 06340-6096

---

Report No. CG-D-04-99

## Evaluation/Validation of an Electronic Engine Speed Pilot on the USCGC TAMPA (WMEC 902)



FINAL REPORT  
OCTOBER 1998



This document is available to the U.S. public through the  
National Technical Information Service, Springfield, VA 22161

Prepared for:

U.S. Department of Transportation  
United States Coast Guard  
Systems (G-S)  
Washington, DC 20593-0001

DNIC QUALITY INSPECTED 4

19990419 046

# N O T I C E

This document is disseminated under the sponsorship of the Department of Transportation in the interest of information exchange. The United States Government assumes no liability for its contents or use thereof.

The United States Government does not endorse products or manufacturers. Trade or manufacturers' names appear herein solely because they are considered essential to the object of this report.

The contents of this report reflect the views of the Coast Guard Research and Development Center. This report does not constitute a standard, specification, or regulation.



Marc B. Mandler, Ph.D.  
Technical Director  
United States Coast Guard  
Research & Development Center  
1082 Shennecossett Road  
Groton, CT 06340-6096



Technical Report Documentation Page

1. Report No. CG-D-04-99	2. Government Accession Number	3. Recipient's Catalog No.	
4. Title and Subtitle  Evaluation/Validation of an Electronic Engine Speed Pilot on the USCGC TAMPA (WMEC 902)		5. Report Date October 1998	
		6. Performing Organization Code Project No. 9207.1.1 / UDI 115	
7. Author(s) Bert Macesker, Robert Desruisseau (R&D Center) Hank Kocevor, Charlie Marino (WMEC 902)		8. Performing Organization Report No. R&DC 20/98	
9. Performing Organization Name and Address U.S. Coast Guard Research and Development Center 1082 Shennecossett Road Groton, CT 06340-6096		10. Work Unit No. (TRAVIS)	
		11. Contract or Grant No.	
12. Sponsoring Organization Name and Address  U.S. Department of Transportation United States Coast Guard Systems (G-S) Washington, DC 20593-0001		13. Type of Report & Period Covered Final Report	
		14. Sponsoring Agency Code Commandant (G-SEN) U.S. Coast Guard Headquarters Washington, DC 20593-0001	
15. Supplementary Notes The R&D Center's technical point of contact is Mr. Bert Macesker, 860-441-2726.			
16. Abstract (MAXIMUM 200 WORDS)  The need to reduce and manage energy and fuel in the Coast Guard was promulgated in Commandant Instruction 4100.2D, dated 6 March 1997. The Coast Guard is required by law to reduce its overall energy consumption and to minimize the use of petroleum fuel in all its facilities and platforms. The Coast Guard Energy Program Director recognizes the need to introduce future low-cost and proven engineering retrofit changes to the fleet that could help meet these goals. Second to personnel costs, fuel is the single largest expense associated with cutter operations.  The Coast Guard Headquarters sponsor, Office of Naval Engineering (G-SEN), requested testing and evaluation of an electronic engine speed pilot on a WMEC-270. The sponsor desired testing of a system that would optimize propeller pitch in addition to engine speed on a controllable pitch propeller, since this was the configuration of most of the Coast Guard's large cutters. Although speed pilots have been in use for several years with crew boats and ferries, the ability to control propeller pitch in addition to engine speed was something relatively new.  A sea trial was performed from 24 through 26 August on the CGC TAMPA to test an electronic engine speed pilot (ESP) system under actual operating loads and sea conditions. A fuel savings of 10% was measured for the standard engine RPM/propeller pitch settings tested using the throttle and pitch automatic control mode. Some of the ESP features did not work and require more development, i.e., best speed and automatic throttle control modes. Measurements from an independent and highly accurate positive displacement fuel meter tracked well with the derived fuel from the ESP. A description of the electronic engine speed pilot system, data analysis, and recommendations are presented. In addition, a high-level fuel savings projection was performed.			
17. Key Words  fuel savings, electronic speed pilot, controllable pitch		18. Distribution Statement This document is available to the U.S. public through the National Technical Information Service, Springfield, VA 22161	
19. Security Class (This Report) UNCLASSIFIED	20. Security Class (This Page) UNCLASSIFIED	21. No of Pages	22. Price

Form DOT F 1700.7 (8/72) Reproduction of form and completed page is authorized.

[ BLANK ]

### **Acknowledgements**

Appreciation is expressed to the crew of the CGC TAMPA for their support throughout the many changes we went through with the system before we could finally put it to the test. Appreciation is also expressed to LT Kacprzyński, U.S. Coast Guard Headquarters Office of Naval Engineering, who provided all of the testing coordination with MLC Atlantic Area and the CGC TAMPA. Appreciation is expressed to Mr. MacPherson of Hydrocomp, Inc. for his analysis of the data and for taking on the role as the engine speed pilot system integrator on the TAMPA prototype.

## TABLE OF CONTENTS

<u>Section</u>	<u>Page</u>
EXECUTIVE SUMMARY .....	viii
1.0 BACKGROUND.....	1
1.1 Sponsor Request.....	1
1.2 EMS-1000 Speed Pilot.....	1
1.3 Fuel Savings Premise .....	2
1.4 Purpose of Test.....	2
2.0 INTRODUCTION.....	2
2.1 Sea Trial Objectives .....	2
2.2 CGC TAMPA Overview .....	3
2.3 Equipment Installation .....	3
3.0 TEST RESULTS .....	5
3.1 Test Approach .....	5
3.2 Test Observations.....	6
3.3 Max Machine Fuel Monitor Comparison to Engine Speed Pilot Fuel Measurements.....	7
3.4 Data Analysis .....	7
3.5 Results .....	12
3.6 Discussion of Vender Analysis .....	13
4.0 SUMMARY/RECOMMENDATIONS .....	14
4.1 Discussion of TAMPA Engine Speed Pilot Fuel Savings.....	14
4.2 Electronic Engine Speed Pilot Considerations for Coast Guard Cutters .....	15
4.3 Recommendations .....	15
Appendix A - Engine Speed Pilot Data Analysis.....	A-1
Appendix B - Hydrocomp, Inc. Data Analysis .....	B-1

## LIST OF FIGURES

<u>Figure</u>		<u>Page</u>
1	Overview of Electronic Engine Speed Pilot Control System.....	4
2	Smart Engine Command and Display System .....	4
3	Illustration of Test Approach .....	6
4	Comparison of Max Machine Fuel Monitor to Engine Speed Pilot Fuel Readings.....	8
5	Total Fuel Consumption – Handle Position 7 (August 26).....	9
6	Port and Starboard Engine RPM – Handle Position 7 (August 26) .....	10
7	Port and Starboard Propeller Pitch – Handle Position 7 (August 26) .....	10
8	Max Machine Fuel Monitor – Handle Position 7 (August 26) .....	11
9	CGC TAMPA Track for Handle Position 7 (August 26) Test Run .....	11
10	Fuel Map Derived for the 18 Cylinder ALCO Diesel Engine.....	13

## LIST OF TABLES

<u>Table</u>		<u>Page</u>
1	CGC TAMPA Speed/Pitch Schedule.....	5
2	Fuel Savings Summary for Test Run 082698C.....	12
3	Annual Fuel Savings Projection using the WMEC-270 Electronic Engine Speed Pilot .....	14

## EXECUTIVE SUMMARY

The need to reduce and manage energy and fuel in the Coast Guard was promulgated in Commandant Instruction 4100.2D dated 6 March 1997. The Coast Guard is required by law to reduce its overall energy consumption and to minimize the use of petroleum fuel in all its facilities and platforms, i.e., cutters. The Coast Guard Energy Program Director, Commandant (G-CFP), listed as an energy goal the reduction of operational costs by at least 3% in FY97 from the established energy baselines. Commandant (G-CFP) recognized the need to introduce future low-cost proven engineering retrofit changes to the fleet to help meet these goals. Second to personnel costs, fuel is the single largest expense associated with cutter operations.

The sponsor, U.S. Coast Guard Headquarters Office of Naval Engineering (G-SEN), requested testing and evaluation of an electronic engine speed pilot on a WMEC-270. The sponsor desired testing of a system that would optimize propeller pitch in addition to engine speed on a controllable pitch propeller, since this was the configuration of most of the Coast Guard's large cutters. Although rpm speed pilots have been in use for several years with crew boats and ferries, the ability to control propeller pitch in addition to engine speed was something new.

A sea trial to test an electronic engine speed pilot (ESP) system under actual operating loads and sea conditions was performed on the CGC TAMPA from 24-26 August 1998. A fuel savings of 10% was measured for the standard ERPM/propeller pitch settings tested using the throttle/pitch automatic control mode. Some of the ESP features did not work and require more development, i.e., best speed and throttle automatic control modes. The independent fuel meter measurements tracked well with the derived fuel from the ESP. A description of the electronic engine speed pilot system, data analysis, and recommendations are presented. In addition, a high-level fuel savings projection was performed.

## 1.0 BACKGROUND

### 1.1 Sponsor Request

The need to reduce and manage energy and fuel in the Coast Guard was promulgated in Commandant Instruction 4100.2D dated 6 March 1997. The Coast Guard is required by law to reduce its overall energy consumption and to minimize the use of petroleum fuel in all its facilities and platforms, i.e., cutters. The Coast Guard Energy Program Director, Commandant (G-CFP), listed as an energy goal the reduction of operational costs by at least 3% in FY97 from the established energy baselines. Commandant (G-CFP) recognized the need to introduce future low-cost proven engineering retrofit changes to the fleet to help meet these goals.

Second to personnel costs, fuel is the single largest expense associated with cutter operations. Consequently, small fluctuations in the price of fuel result in broad impacts on operations. Rising fuel costs have a disproportionate negative impact on overall operational capability thereby increasing the importance of evaluating methods to reduce fuel consumption while maintaining a high operational tempo.

There have been recent vendor claims that electronic engine speed pilot systems (throttle control systems only) offer a fuel savings on the order of 15%. Usually, these claims are based on an analysis performed by the vendor for further marketing of the product.

The U.S. Coast Guard Research & Development Center (R&D Center) received a request for support from the U.S. Coast Guard Headquarters Office of Naval Engineering (G-SEN).<sup>1</sup> The request asked that the R&D Center conduct a test and evaluation (T&E) of potential fuel savings associated with using an electronic speed pilot on a 270 foot Coast Guard cutter. The requirements of the request included:

- (a) Coordinate the installation of an electronic engine speed pilot and instrumentation to validate any fuel savings for the WMEC-270s and the potential for similar savings for the Coast Guard fleet.
- (b) Design and submit an experimental test plan for analyzing data collected with the installation of an engine speed pilot on a 270-foot Coast Guard cutter.
- (c) Provide a final report on the T&E results of the engine speed pilot.

### 1.2 EMS-1000 Speed Pilot

The impetus for this project came out of R&D experimental work with equipment being developed for shipboard emission measurements. The R&D Center was experimenting with alternatives to strain gauge installations on propeller shafts for developing shaft horsepower measurements. Horsepower measurements are required to normalize the in-situ shipboard

---

<sup>1</sup> RDC Request for Support from Engineering Logistics Center, No. 11000, undated.

emission measurements. Instrumentation was selected that derived a calculated engine horsepower based on engine rack position, engine rpm, and factory specifications. The Steller Marine EMS-1000 equipment employed could also be used to optimize engine rpm. This was casually observed in the tugboat COUGAR results.<sup>2</sup> Although the evaluation of the EMS-1000 fuel savings capability was only a secondary objective to this ship test, an indication of fuel savings was apparent when the engine speed pilot was engaged.

### 1.3 Fuel Savings Premise

Any marine engineering text will describe the total propulsion resistance of a ship as being approximately proportional to the square of the ship speed. The effective power of the ship is proportional to the propulsion resistance and ship speed. This means that the effective power of the ship and also horsepower of the engine is proportional to the cube of the speed of the ship.

The power required at the propeller varies with approximately the cube of speed of rotation. Therefore, it stands to reason that an increase or decrease in engine rpm has a cubed effect on fuel used. Backing down on the engine speed ever so slightly can have a pronounced effect on fuel consumed. In addition, trying to maximize a ship's performance such as balancing the main diesel engines (MDEs) by interpreting ship and engine characteristics is very difficult through simple observations, e.g., looking at coarse analog gauges or by *engineers ear*. A system that provides closed loop digital control offers the best prospects for improved efficiency.

The sponsor requested the ability to optimize propeller pitch in addition to engine speed on a controllable pitch propeller, since this was the configuration of most of the Coast Guard's large cutters. Although rpm speed pilots have been in use for several years with crew boats and ferries, the ability to control propeller pitch in addition to engine speed was something new.

### 1.4 Purpose of Test

The primary objective of the test was to evaluate and quantitatively validate the fuel savings associated with a low-cost retrofit of an engine speed pilot to a WMEC-270.

## **2.0 INTRODUCTION**

### 2.1 Sea Trial Objectives

The primary objectives of the sea trial performed from 24-26 August were to provide the opportunity to troubleshoot and fine tune the electronic speed pilot (ESP) system under actual operating loads and sea conditions, and collect some underway data with qualified technical representatives on board. The results of this sea trial provide information needed to: 1) determine if the ESP can reliably work with the TAMPA engine control, 2) determine if there is an indication of fuel savings, and 3) provide a basis for a go/no-go decision to keep the electronic speed pilot on board for continued evaluation.

---

<sup>2</sup> "Portable Emissions Testing of a 105-FT Commercial Tug," October 1996, Report No. CG-D-07-97.

## 2.2 CGC TAMPA Overview

The thirteen WMEC 270s are powered by twin 18 cylinder ALCO series 18V-251 (medium speed MDEs) that provide 3650 HP each at 1025 rpm. They have twin controllable pitch propellers, and their endurance is 9500 miles at 13 knots. These cutters are approximately 20 years old, and it is likely that they may see another 20 years of service before being phased out by the next generation of deep water replacements. At their top end speed, the WMECs consume about 350 gph of fuel. The TAMPA has three modes of speed/pitch control. These are emergency manual (EM), engineering control center (ECC) control, and pilot house control. In both the pilot house and ECC control, the rpm of the propeller is changed in steps in accordance with a speed/pitch schedule. The propeller pitch is simultaneously varied in accordance with this schedule to achieve a given ship speed. Although a variable pitch propeller can give an infinite number of pitch/engine settings to achieve a given speed, ships generally operate at selected settings defined by a pre-programmed pitch schedule. Ideally, this setting would be where the engine operates at the lowest specific fuel consumption (SFC) (lb/hp-hr) for each speed. Obviously, this is not always the case. For example, the new Coast Guard ocean-going buoy tender JUNIPER's pitch schedule is dictated more by the avoidance of cavitation and excessive vibration than best fuel use.

## 2.3 Equipment Installation

The engine speed pilot installed on the TAMPA was a prototype. Therefore, it was important to be as non-intrusive to the ship's normal engine control as possible. The manual sticks in the engineering control center (ECC) were replaced with electronic throttle and pitch controls. The procedure established for engaging the ESP was for the bridge to give up pilot-house control of the main engine diesels (MDEs) and pass control down to engineering. The ECC engineers would take control in emergency manual (EM) mode and at that point they could engage the ESP. While in the EM mode, when the ESP had control of the engines, complete control of the engines and propellers could be made immediately available by moving the new ESP sticks.

In the EM mode the Kobelt, Inc. control CPU and actuators were given a 24V power supply and 24V backup batteries for safety. In addition, if the backup batteries failed, the engineers could still have direct manual control of the actuators for pitch and throttle in the engine room. This prototyping of an ESP on a Coast Guard cutter required the project personnel, including the ship's crew, to go to great lengths to make the vessel command feel comfortable before given the opportunity to field test this new technology.

Figure 1 presents a high level view of the ESP control system installation. There is a Kobelt, Inc. control system CPU that monitors the input from the control heads, i.e., the new electronic sticks. The Kobelt, Inc. CPU adjusts the actuators by sending electrical signals to the actuators. The resulting movements of the actuators are fed back to the CPU by a potentiometer to close the control loop. The Smart Engine software, shown in Figure 2, monitors rpm, rack position on the MDEs, and propeller pitch. It provides the control for the throttle and pitch on the controllable pitch (CP) wheel.

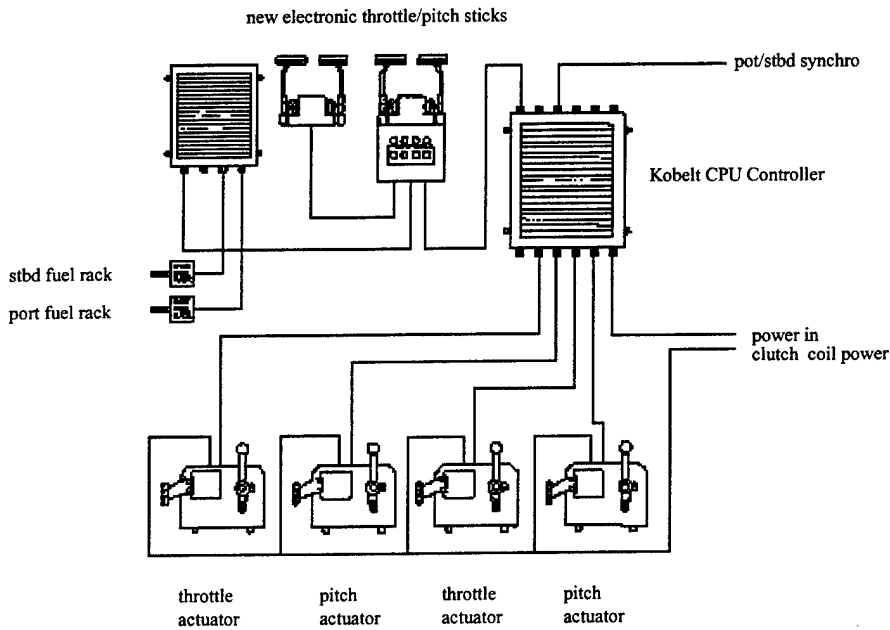

Figure 1. Overview of Electronic Engine Speed Pilot Control System

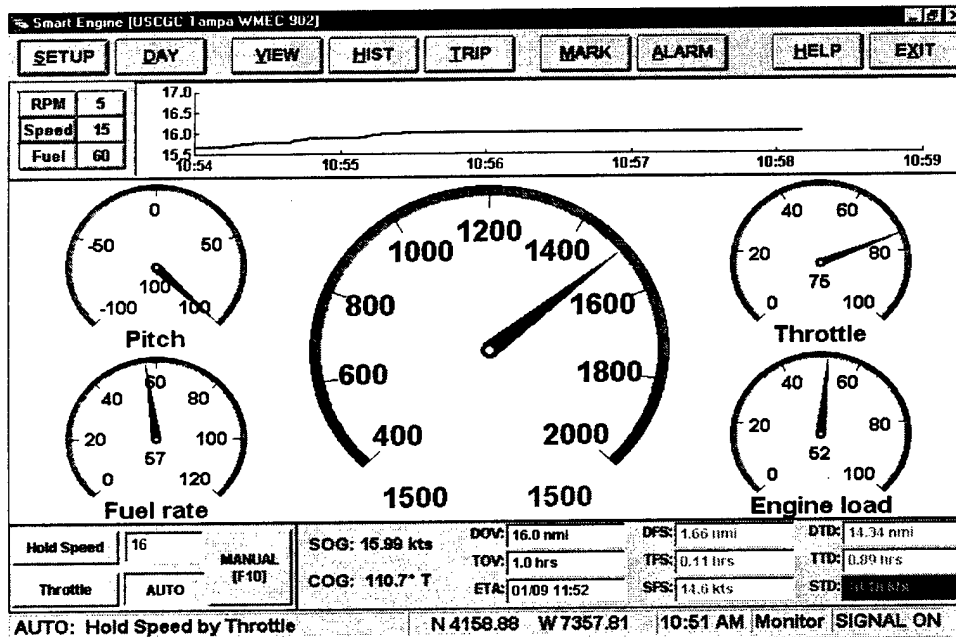

Figure 2. Smart Engine Command and Display System

The Smart Engine software, depicted in Figure 2, was used as the command and display system that interfaces with the Kobelt, Inc. control hardware and software. The smart engine software runs on a standard PC on Windows 4.0. The command and display unit monitored and recorded Global Positioning Satellite (GPS) information from a dedicated Magnavox GPS receiver and

echoed the display up to a bridge monitor. Initially the actuators were installed inside the TANO consoles in ECC. However, because the mechanical cables from the actuators to the CP wheel and engine throttle were over 20 feet long with lots of bends, it appeared that in some instances the control response was not as immediate as desired. The potential problems with these cables in terms of flexing and bending over long distances were corrected by moving the actuators down into the engine room within several feet of both the throttle and CP wheel. An independent fuel meter was custom designed for the TAMPA's main diesel engine. The highly accurate fuel monitor was built by Max Machine, Inc. It is a positive displacement fuel meter with a conditioning and metering package that includes a filter, vapor eliminator, heat exchanger, pump, regulator, thermocouple and pressure gauges. This fuel meter has a calibration accuracy of  $\pm 0.25\%$ .

### 3.0 TEST RESULTS

#### 3.1 Test Approach

The test approach consisted of first selecting a desired handle position setting. The engineering officer (EO) and main propulsion assistant (MPA) recommended testing a range of handle positions from handle position 5 through handle position 8. Although the TAMPA has handle position settings from 1 through 10, it was felt that the test range represented speed settings for 80% of their time underway. Vessel speeds associated with handle position 4 and less usually resulted in uncomfortable transit speeds, i.e., increased vessel motions. The highest vessel speeds associated with handle positions 9 and 10 are the least efficient transit speeds. The Cutter Operations Division did not feel comfortable running the prototype ESP above handle position 8. Table 1 presents the speed and pitch schedule for the TAMPA.

**Table 1. CGC TAMPA Speed/Pitch Schedule**

Handle Position	Engine rpm	Shaft rpm	Pitch %	~SOG knots
1	400	101	10	-
2	400	101	34	4
3	440	113	50	6
4	520	133	60	7
5	580	146	68	10
6	640	164	78	11
7	720	184	89	14
8	800	204	98	15
9	900	228	100	17
10	1025	260	100	19

In emergency manual the EO would manually emulate the handle position settings, i.e., match rpm and pitch settings to the speed/pitch schedule in Table 1. The ESP test was initiated after the vessel speed reached a steady state speed. The Smart Engine software was initially placed in

monitor mode. The data logger for the Max Machine fuel monitor, installed on the port main diesel engine (MDE), was initiated at the same time. The Smart Engine calculated a running average speed over ground (SOG) while in the monitor mode. This mode would be maintained for some time to achieve steady state conditions and a good average speed. The ESP was then engaged in the hold speed mode (throttle/pitch automatic control mode) at the average running speed observed. Figure 3 illustrates this test approach. Originally, the test plan called for testing an automatic throttle control mode; however, this did not work properly and was aborted for the remainder of the sea trial.

The TAMPA fin stabilizer control system was energized at all times throughout the test to minimize roll motions.

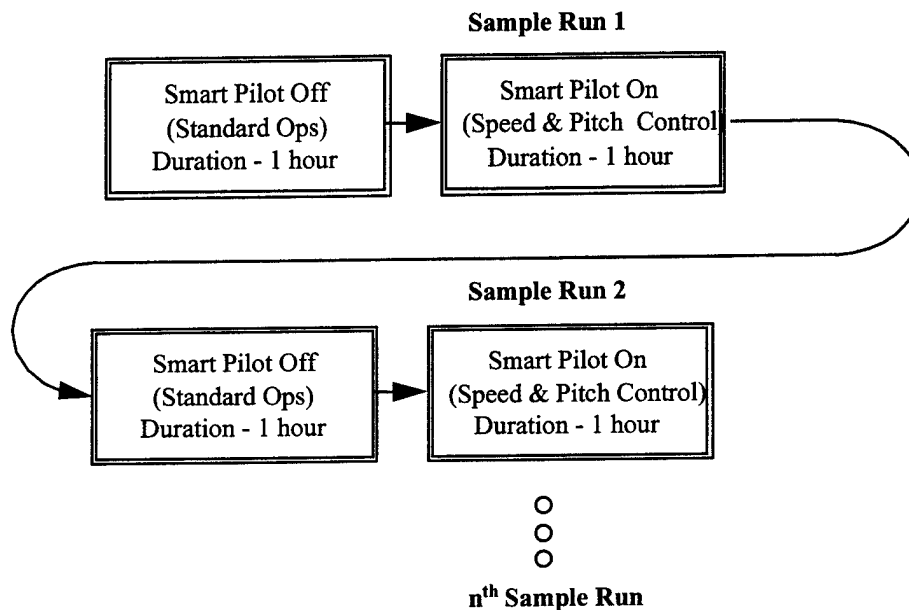

**Figure 3. Illustration of Test Approach**

### 3.2 Test Observations

On 24 August the automatic throttle control mode was attempted at handle position 6. When this was engaged, the pitch control dropped out. The throttle control mode did not work. This feature will require a fix with both the Smart Engine and Kobelt controller software. The Hydrocomp, Inc. representative wrote a software patch to override the Kobelt control commands, i.e., send constant pitch commands to the actuators to effectively hold pitch while the throttle is optimized. The automatic throttle mode with the software fix was attempted the same day. However, the port pitch dropped out again when the throttle control mode was engaged. The test team decided to abort testing of this feature.

During the early ESP test runs it was observed that the pitch rate would often quickly ramp up to 100%. The Hydrocomp, Inc. representative modified the software to reduce the slew rate of the

pitch control. This provided some improvement in that the engines did not seem to get bogged down as much.

Testing was temporarily aborted on 25 August to fix a fuel leak in a flange connection in a pipe run to the Max Machine fuel monitor. The crew reported several nuisance leaks during its use on other occasions as well.

There consistently appeared to be a downward trend in all of the Max Machine fuel monitor readings on the port MDE. However, it was also observed that the rpm on the port MDE lagged the starboard MDE rpm sometimes as much as 20-40 rpm.

The ESP Best Speed mode was attempted on August 25. As soon as this mode was engaged, the port pitch dropped out. No more attempts were made with this mode of operation. The virtual software buttons for the best speed and throttle only mode were disabled in the software.

### 3.3 Max Machine Fuel Monitor Comparison to Engine Speed Pilot Fuel Measurements

Figure 4 presents a direct comparison of the Max Machine fuel monitor fuel readings to the engine speed pilot fuel calculations on the port MDE. This was done for Max Machine file 082598e.log for handle position 8. It is clear from Figure 4 that the derived fuel from the engine speed pilot (the trace on top) tracks well with the Max Machine fuel flow meter. There is an approximate 18% difference between them. Because the ESP and Max Machine Fuel monitor data track well, it is reasonable to expect the total fuel consumption percent difference measured before and after the ESP was engaged to be an accurate representation of the percent fuel saved.

The ESP fuel derivation uses information from the rack, swept injector volume, and engine rpm to estimate the fuel injector volume thrown into the engine cylinders. Although the best available data were used to estimate fuel injector volume and stroke, a more accurate representation of the fuel can be back-engineered using the Max Machine fuel monitor results.

### 3.4 Data Analysis

There were over 15 test runs logged during the three-day sea trial. Many of these runs were not considered to be good test runs for various reasons including coarse changes of ten degrees or more, or for cutting the test short, e.g., whales in the operating area. Whether the ESP was in the monitor or ESP mode, it continuously logged the following information:

- date/time; GPS SOG; heading; port and starboard engine rpm; port and starboard pitch; port and starboard fuel; port and starboard engine load; port and starboard engine rack.

The Max Machine fuel monitor logged the following data:

- date/time; port fuel; fuel temperature.

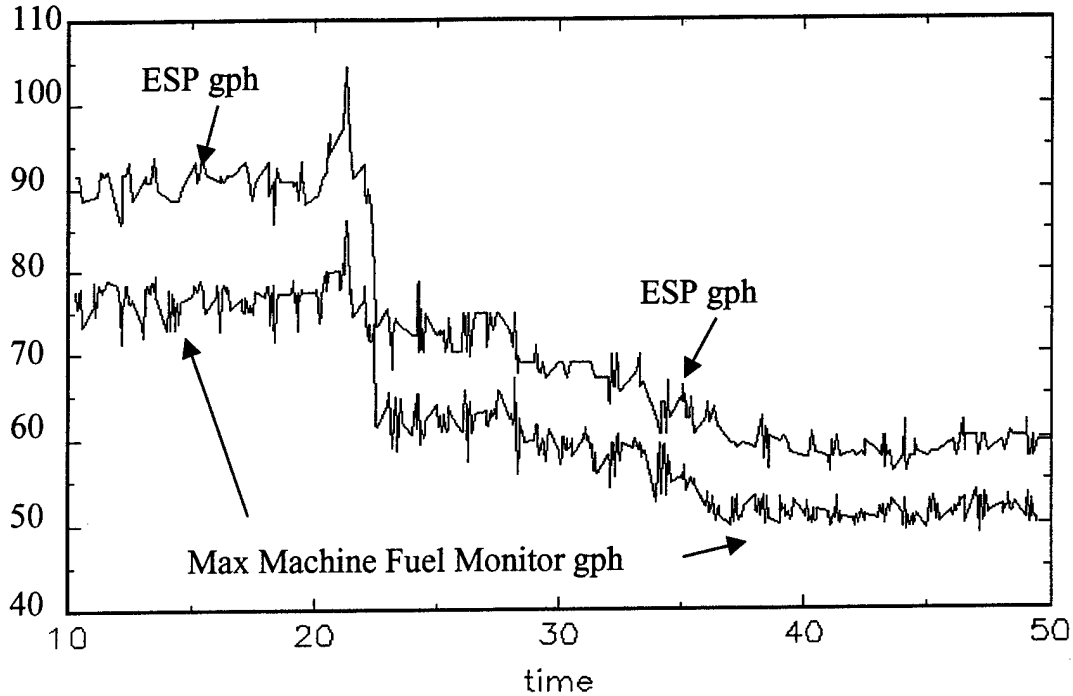

**Figure 4. Comparison of Max Machine Fuel Monitor to Engine Speed Pilot Fuel Readings**

During the test runs, the bridge recorded wind speed and direction, doppler speed, and sea conditions.

The RDC analysis approach was to select several runs during the test conduct that held the same steady state average SOG after the ESP was engaged and had five degrees or less course adjustment. The purpose for selecting sample runs that had the same before and after average speed is because fuel use is sensitive to vessel speed. The rule of thumb is,

$$\text{fuel} = f(v^3),$$

where 'v' is the speed through the water of the vessel. In addition, many of the early runs resulted in average SOGs under ESP control of 0.5 to nearly 1.0 knot less than the standard ops average speed. During these early runs, the ESP would often increase pitch quickly. The MDEs have a torque limiter which may have been preventing the ESP from achieving the target hold speed. The software was modified to reduce the pitch slew rate which resulted in speeds more closely matched before and after the ESP was engaged.

During the sea trial it became apparent that looking at the Max Machine fuel monitor readings on the port MDE alone was not enough to reach any direct conclusions on fuel saved. It was observed that the port MDE rpm often lagged behind the starboard MDE rpm by 20-40 rpm. The EO made some measurements on the fuel racks and noted that they were different. They would

have had to replace the port MDE governor to correct the fuel rack differences between the port and starboard engines. It was decided not to do this because it would have been a several hour job for the crew.

A test run that met the criteria, i.e., same SOG before and after ESP was engaged, was performed on 26 August at an handle position 7. Figure 5 presents the total fuel consumption time history for this run. Noted on this data is when the ESP was engaged and where data were averaged. Generally, it would take 15-30 minutes for the average speed to settle out under ESP control. Figure 6 presents the port and starboard engine rpm. Figure 7 presents the port and starboard pitch. Max Machine fuel monitor results for this run are presented in Figure 8.

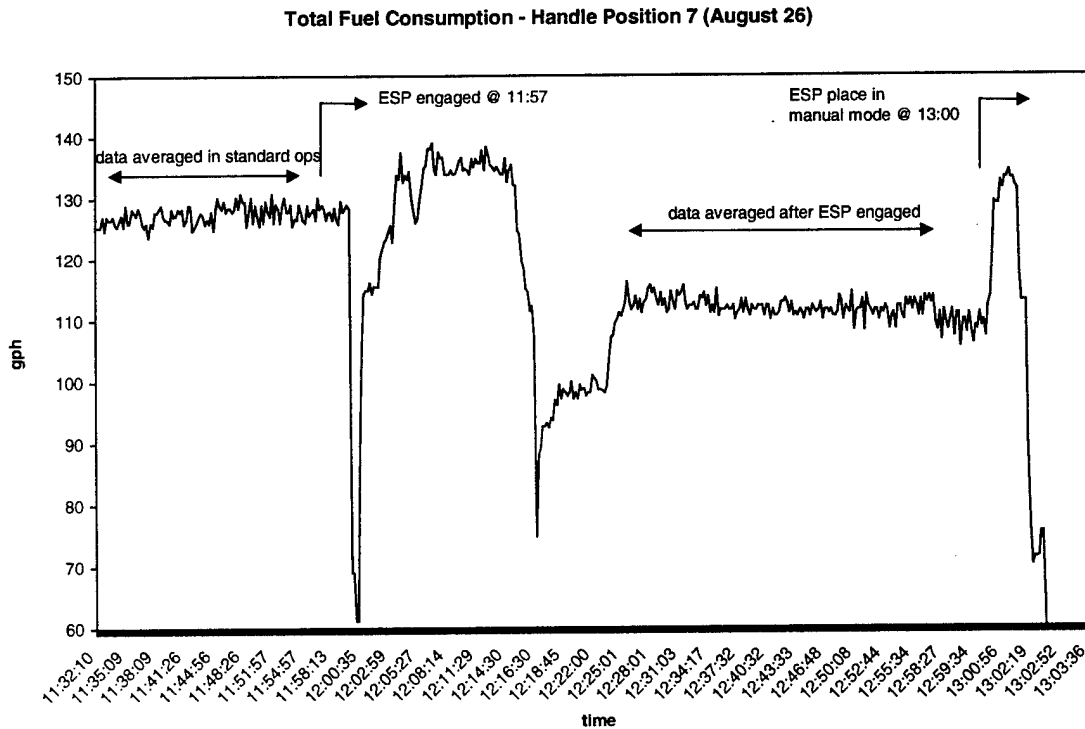

**Figure 5. Total Fuel Consumption – Handle Position 7 (August 26)**

Port and Starboard Engine RPM - Handle Position 7 (August 26)

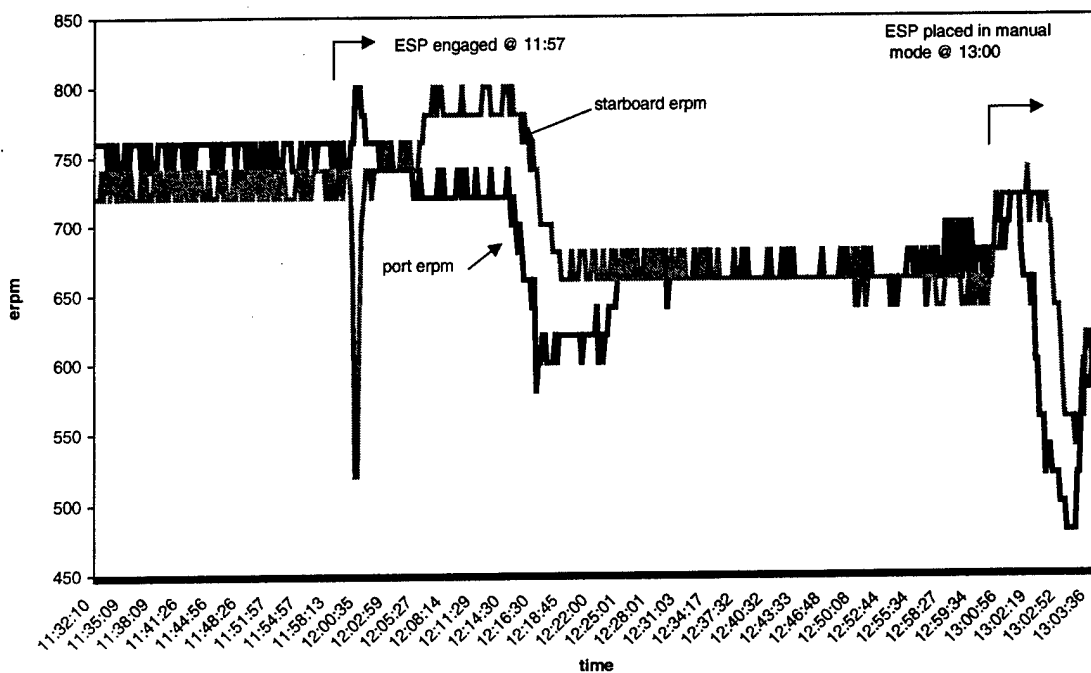

Figure 6. Port and Starboard Engine RPM – Handle Position 7 (August 26)

Port and Starboard Pitch - Handle Position 7 (August 26)

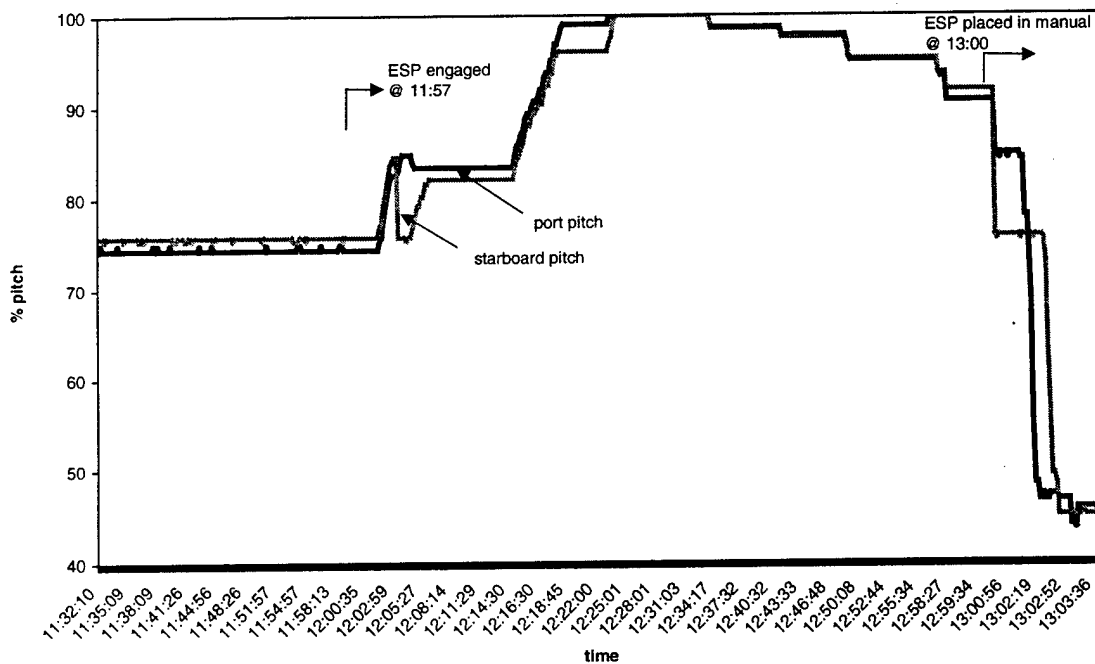

Figure 7. Port and Starboard Propeller Pitch – Handle Position 7 (August 26)

Max Machine Fuel Monitor - Handle Position 7 (August 26)

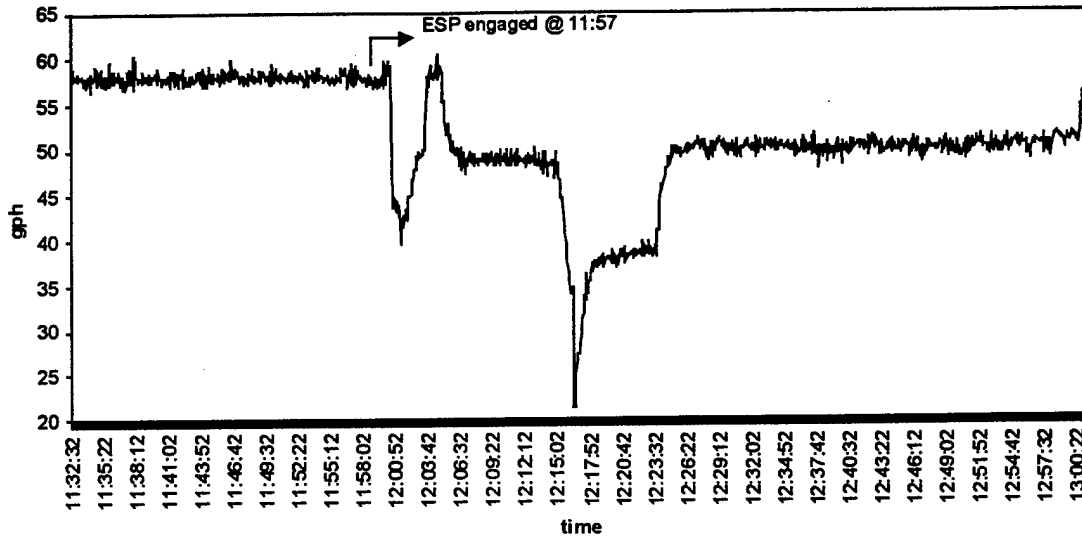

Figure 8. Max Machine Fuel Monitor – Handle Position 7 (August 26)

Course fluctuations less than  $\pm 5$  degrees of initial heading were one of the criteria used to determine whether the test run was valid. The ESP logged GPS position was used to track the vessel during testing. Figure 9 is a plot of the GPS latitude and longitude data for this test run, and shows the straight course track of the ship from right to left.

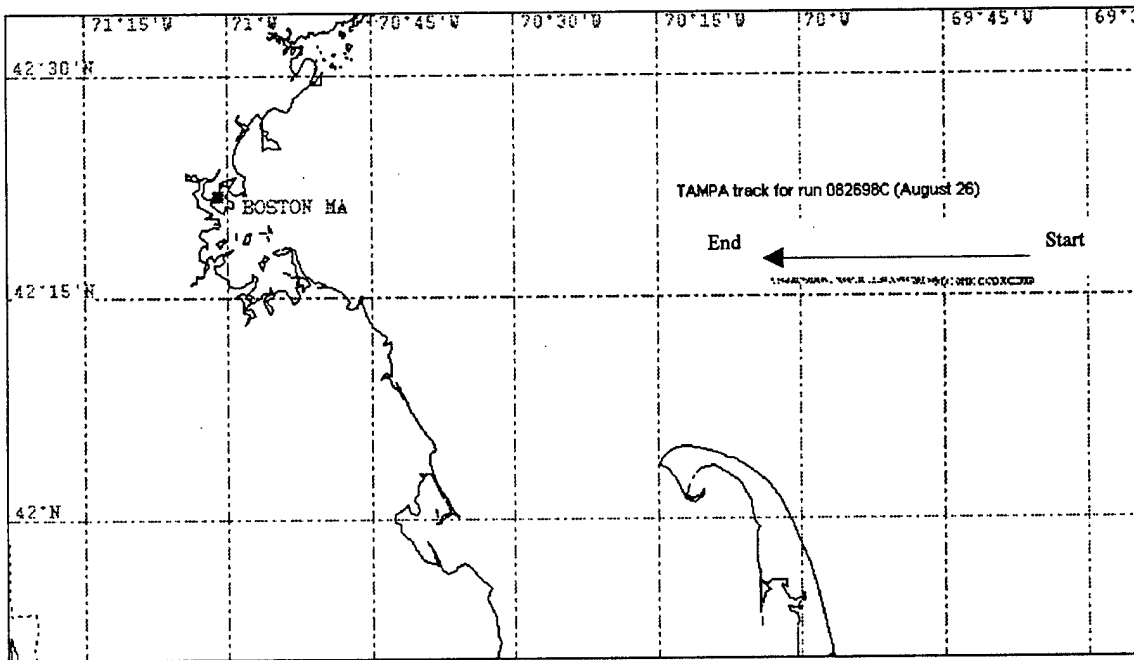

Figure 9. CGC TAMPA Track for Handle Position 7 (August 26) Test Run

Table 2 presents the results for this run. All of the averaged data presented were averaged over the same standard operations and ESP mode time periods. For this test run, a fuel savings of 12% was determined. Three runs that were analyzed are presented in Appendix A.

**Table 2. Fuel Savings Summary for Test Run 082698C**

Date: 26-Aug-98  
 ESP File: 19980826\_1132  
 Max Machine File: 082698C.LOG  
 Handle Position: 7

		Average Speed	Average of Course	ESP Total Fuel	Fuel Monitor
<b>Standard Ops Mode</b>					
Data Analysis Start Time	11:35	13.27 knots	270 degrees	127.48 gph	57.93 gph
Data Analysis End Time	11:55				
<b>Engine Speed Pilot Mode</b>					
ESP engaged @	11:57	13.27 knots	273 degrees	112.02 gph	50.11 gph
Data Analysis Start Time	12:26				
Data Analysis End Time	12:57				
<b>Fuel Savings:</b>				<b>12.13%</b>	<b>13.49%</b>

In some of the test runs the pitch would, after achieving steady state, reach its maximum limits or be close to it. This was not unexpected. The fuel map that was pieced together for this project by Hydrocomp, Inc. was based on pieces of data obtained from Fairbanks Morse and the U.S. Coast Guard Engineering Logistics Center (ELC). Figure 9 presents the pieced together fuel map programmed into the Smart Engine software for this project. An original fuel map for WMEC-270 ALCO engines could not be located. A general observation could be made that the TAMPA speed/pitch schedule is not optimal. If the schedule were changed to reflect the best speed/pitch combination, then it might be expected that there would not have been as much of a fuel savings as demonstrated. However, the ESP performed as it should in seeking out the best fuel consumption. It can be seen that as the rpm increases along the lines-of-constant break horsepower (BHP), specific fuel consumption (SFC) increases. Generally, the speed pilot cuts back on rpm thereby reducing fuel consumption. However, to achieve the same SOG, it must also increase pitch. Usually increasing pitch on a CP propeller results in higher efficiency.

### 3.5 Results

The average fuel savings from the three test runs, analyzed in detail in Appendix A, was 10%.

### CGC TAMPA Derived Fuel Map

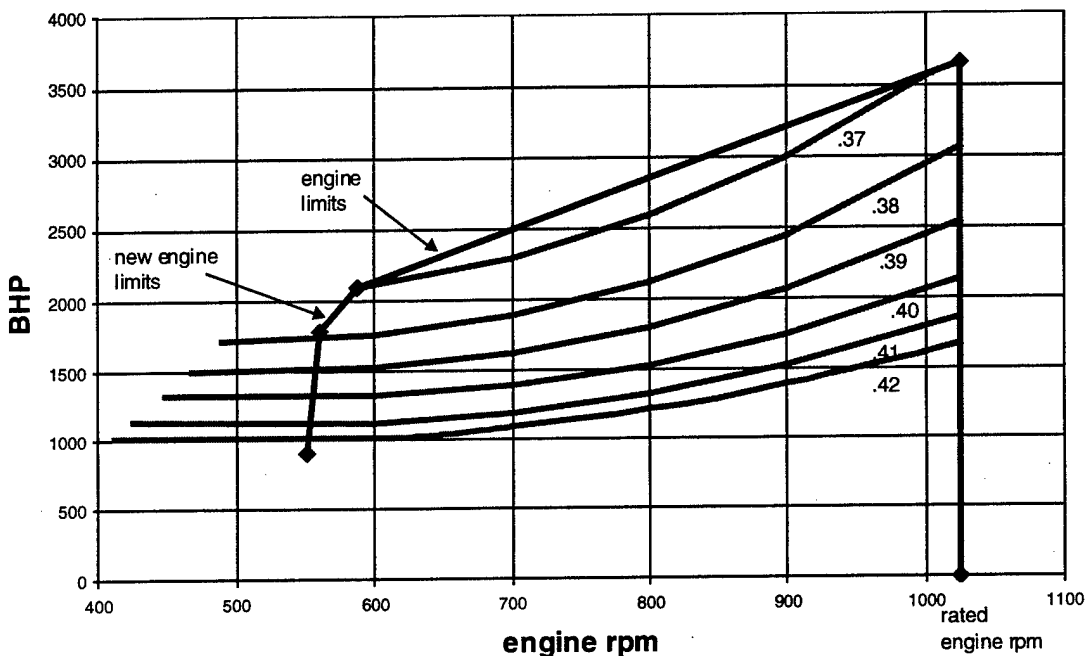

Figure 10. Fuel Map Derived for the 18 Cylinder ALCO Diesel Engine

### 3.6 Discussion of Vendor Analysis

Hydrocomp, Inc. conducted an analysis of a number of test runs, including test runs that had average speeds under ESP control slightly less than when in the standard operations mode. The approach taken to account for the slight reduction in average speed under ESP control was to normalize fuel by:

$$F_{esp} * (V_{so} / V_{esp})^3$$

Where,

$F_{esp}$  is the average total fuel under ESP control

$V_{so}$  is the average standard ops speed

$V_{esp}$  is the average speed under ESP control.

This was a conservative approach based on the approximation that fuel rate is a function of speed cubed. A more rigorous approach would be to look at relevant power curves in the speed range of interest. ELC provided ALCO engine data that demonstrated

$$\text{power} = f(\text{speed}^{2.74}).$$

From the ALCO/COLTEC fuel curve it can be shown that

$$\text{fuel} = f(\text{power}^{0.827}).$$

Therefore, a more rigorous relationship between fuel and speed would be

$$\text{fuel} = f(\text{speed}^{2.3}).$$

This would increase the fuel savings calculated in Appendix B.

#### 4.0 SUMMARY/RECOMMENDATIONS

##### 4.1 Discussion of TAMPA Engine Speed Pilot Fuel Savings

Hydrocomp, Inc. provided an analysis of a number of test runs. These results are attached as Appendix B. Analysis of the runs selected in Appendix B demonstrated average fuel savings of 12%. The RDC analysis of selected test runs demonstrated fuel savings of 10%. A high-level fuel savings projection is presented in Table 3. This projection is based on using the fuel savings results of 10% from this sea trial, approximate duty cycle documented in a recent RDC energy audit<sup>3</sup> on the CGC TAHOMA (WMEC-908), and the assumption that the ESP gives equivalent results with single engine operations.

**Table 3. Annual Fuel Savings Projection using the WMEC-270 Electronic Engine Speed Pilot**

Speed Range	Engine Alignment	Operating Hours	GPH	Gallons
< 9 kts	Single screw	653	60	39,180
9-13 kts	Single screw	823	80	65,840
9-13 kts	Dual screw	823	90	74,070
13-16 kts	Dual screw	1035	170	175,950
> 16 kts	Dual screw	409	240	<u>98,160</u>
			<b>total</b>	453,200
			<b>@ \$0.90 per gallon 10% is \$41,000</b>	

<sup>3</sup> "Ship Energy Management Audit USCGC TAHOMA (WMEC 908)," RDC, June 1998.

## 4.2 Electronic Engine Speed Pilot Considerations for Coast Guard Cutters

It is not appropriate to translate directly the fuel savings observed on the TAMPA to other Coast Guard vessels with different hull forms and power plants. However, based on the evidence seen here there is confidence that some degree of fuel savings can be achieved with the installation of ESP technology on the WMEC-270 class. It is expected that the degree of fuel savings between the different cutters in the WMEC-270 class would differ. It is difficult to distinguish the fuel savings attributable to the ESP, fuel consumption related to MDE condition, optimal speed and pitch schedule, etc. This was beyond the scope of this R&D technology demonstration. A number of ESP considerations are provided below:

1. Irrespective of the variation in operations from one cutter to another, a low-cost retrofit that would optimize fuel consumption real-time would also provide cost savings.
2. Developing accurate fuel consumption and engine performance profiles for different mission activities such as law enforcement patrols, defense operations with the Navy, etc., would provide a more discrete level of fuel use for the operational planners.
3. Accurate data reflecting present day operating tempos would reveal how many hours and at what speeds cutters steamed in various operations. Better planning might be done in terms of fuel allocation or best use of remaining fuel. Advanced planning using real data could help the fleet planners achieve scheduling goals and assignments within fuel allocations.
4. The TAMPA could serve as a test platform for other fuel conservation retrofits for the fleet. The ESP can log data for complete underway tours in a monitor mode.

## 4.3 Recommendations

A number of recommendations for the ESP on the TAMPA are as follows:

1. Modify the Smart Engine software to allow for single engine operations and leave the Max Machine fuel monitor on for one more patrol. Testing single engine operations on the port MDE would provide more quantitative estimates of fuel savings. The Max Machine fuel monitor should be removed after this test because of nuisance leaks in the lines to the fuel meter.
2. The ESP system tested was not off-the-shelf as was the original intent. A more robust system needs to be developed for Coast Guard cutters. Naval Engineering should consider holding a workshop of propulsion technical managers and operations staff to develop specific feature requirements for a Coast Guard ESP. Although a couple of the TAMPA ESP features demonstrated the need for more work such as the 'hold throttle only' or 'best speed mode', it is unclear if they would even be used. A simple statistical analysis could help define a more suitable system.

3. Consider the integration of the ESP directly into the ship's engine control system so that the ESP could be run directly from the pilot house.
4. Set up a database of TAMPA ESP data to determine long-term fuel reduction and related cost savings.

**Appendix A**  
**Engine Speed Pilot Data Analysis**

Date: 25-Aug  
 ESP File: 19980825\_1723  
 Max Machine File: 082598H.LOG  
 Handle Position: 7

		Average Speed	Average of Course	ESP Total Fuel	Fuel Monitor
<b>Standard Ops Mode</b>					
Data Analysis Start Time	17:29	13.32 knots	79 degrees	129.2 gph	58.9 gph
Data Analysis End Time	17:52				
<b>Engine Speed Pilot Mode</b>					
ESP engaged @	17:57	13.28 knots	84 degrees	114.6 gph	47.9 gph
Data Analysis Start Time	18:14				
Data Analysis End Time	18:36				
				<b>Fuel Savings: 11.30%</b>	<b>18.50%</b>

Date: 26-Aug  
 ESP File: 19980826\_1132  
 Max Machine File: 082698C.LOG  
 Handle Position: 7

		Average Speed	Average of Course	ESP Total Fuel	Fuel Monitor
<b>Standard Ops Mode</b>					
Data Analysis Start Time	11:35	13.27 knots	270 degrees	127.48 gph	57.93 gph
Data Analysis End Time	11:55				
<b>Engine Speed Pilot Mode</b>					
ESP engaged @	11:57	13.27 knots	273 degrees	112.02 gph	50.11 gph
Data Analysis Start Time	12:26				
Data Analysis End Time	12:57				
				<b>Fuel Savings: 12.13%</b>	<b>13.49%</b>

Date: 26-Aug  
 ESP File: 19980826\_1336  
 Max Machine File: 082698E.LOG  
 Handle Position: 5

		Average Speed	Average of Course	ESP Total Fuel	Fuel Monitor
<b>Standard Ops Mode</b>					
Data Analysis Start Time	13:39	10 knots	232 degrees	61.04 gph	25.09 gph
Data Analysis End Time	13:50				
<b>Engine Speed Pilot Mode</b>					
ESP engaged @	13:51	9.8 knots	237 degrees	57.42 gph	20.36 gph
Data Analysis Start Time	14:29				
Data Analysis End Time	14:40				
				<b>Fuel Savings: 5.93%</b>	<b>18.90%</b>

**Total Fuel Consumption - Handle Position 7 (August 25)**

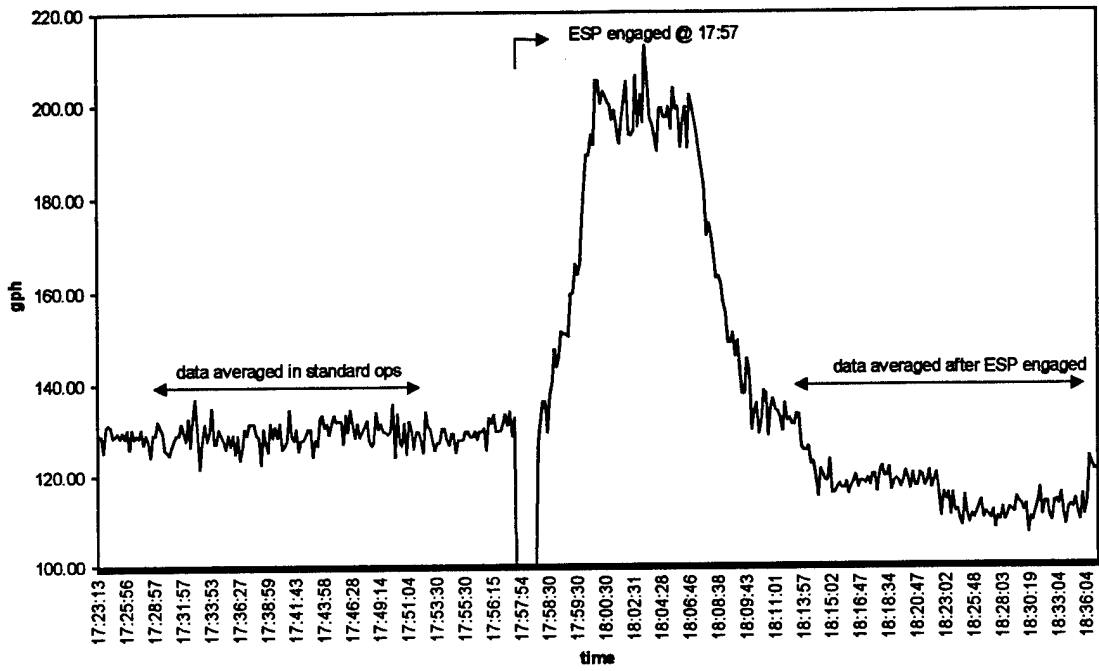

**Max Fuel Monitor Data - Handle Position 7 (25 August)**

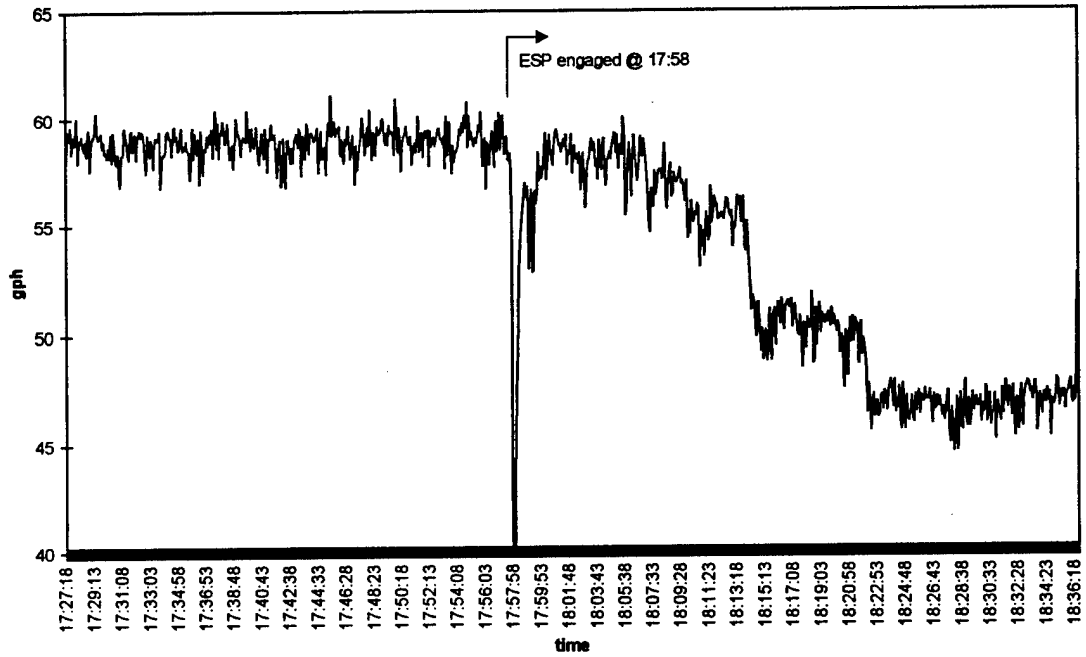

### Total Fuel Consumption - Handle Position 7 (August 26)

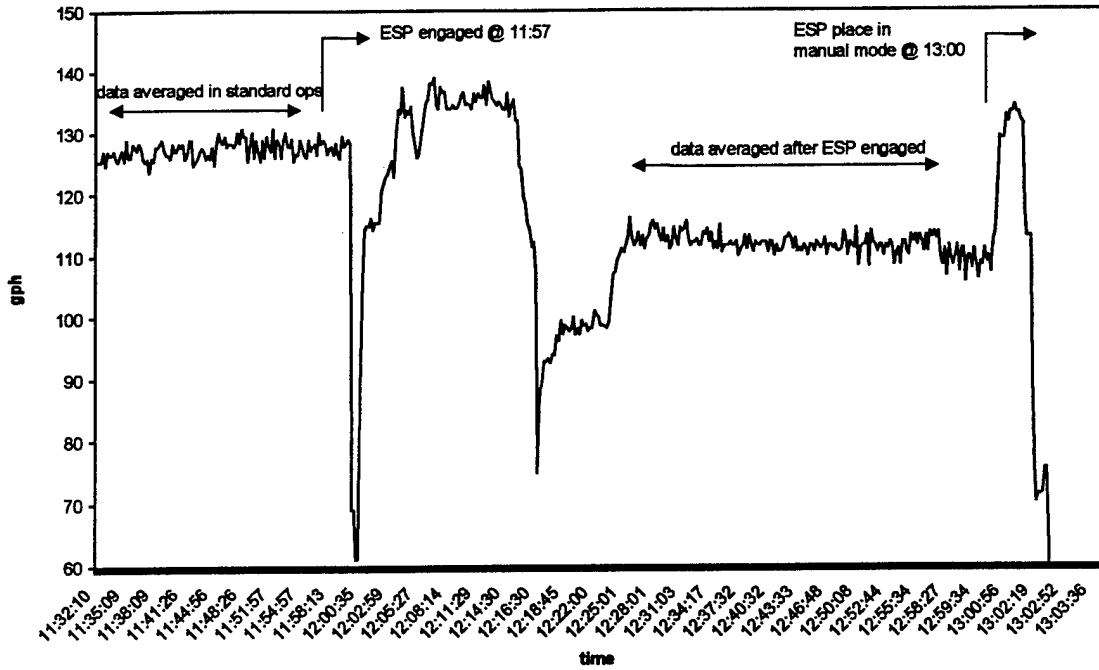

### Max Machine Fuel Monitor - Handle Position 7 (August 26)

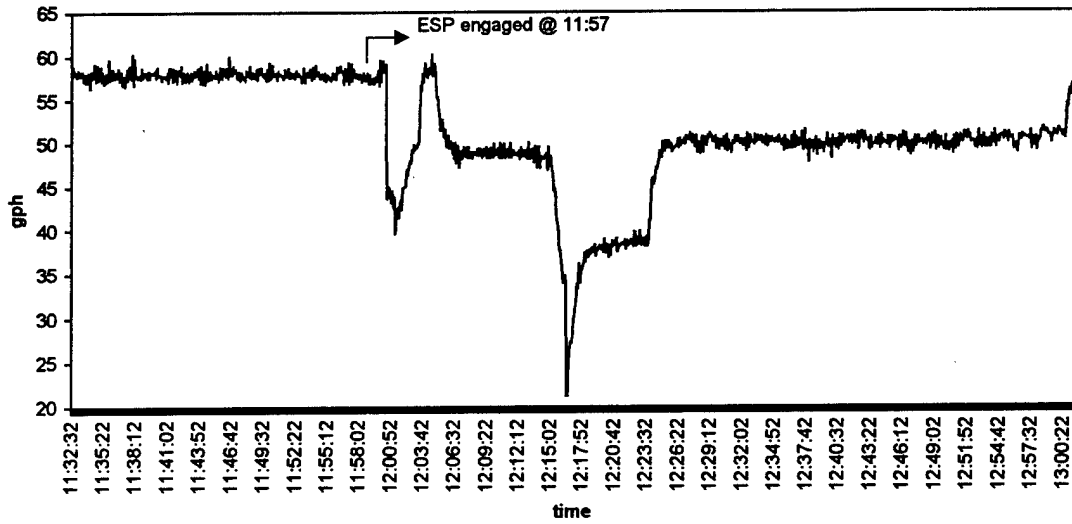

Total Fuel Consumption - Handle Position 5 (August 26)

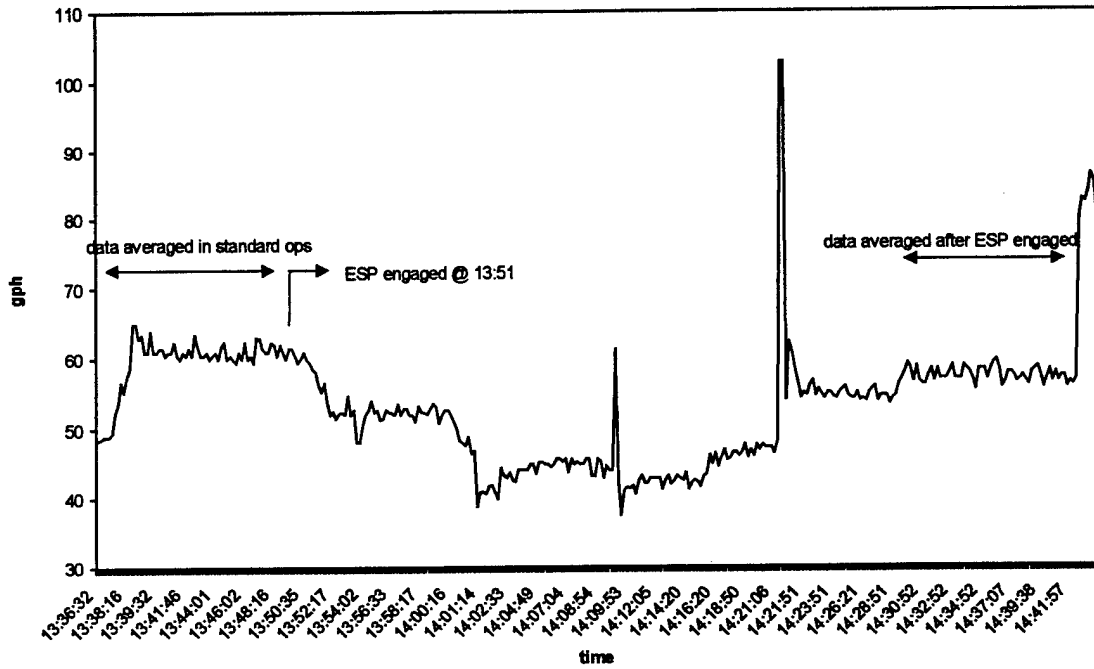

Max Machine Fuel Monitor - Handle Position 5 (August 26)

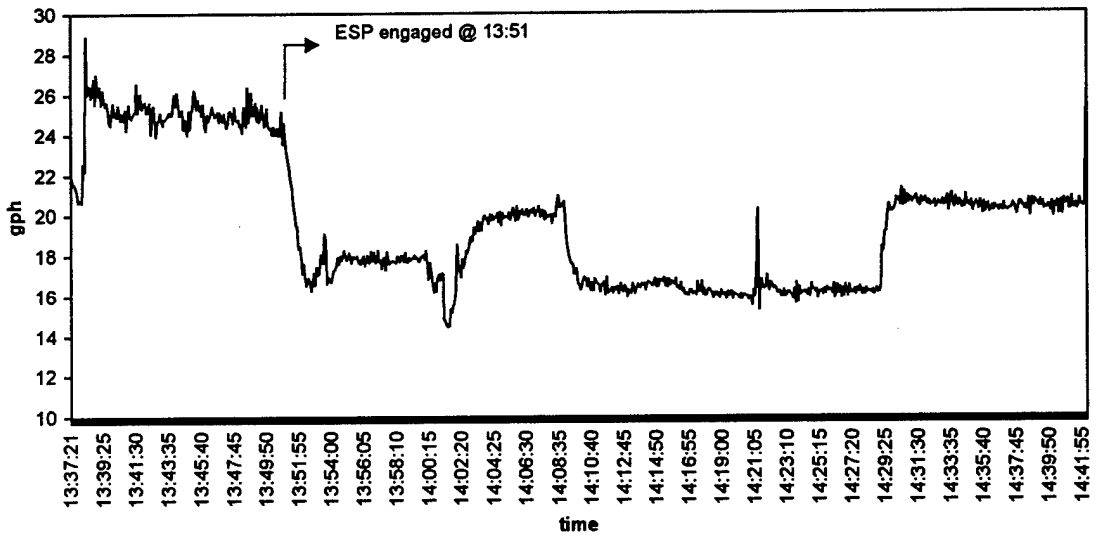

[ BLANK ]

**Appendix B**  
**Hydrocomp, Inc. Data Analysis**

THD	SETTING			BY SETTING			BY SMARTENGINE				% SAVED	NOTES
	Duration	Course	Speed	Duration	Course	Speed	Duration	Course	Speed	Fuel %		
19980824_1544.THD	6	0:30:25	71	10.9	50	10.1	0:28:29	74.1	74.1	93.5	6.5	Course change
19980824_1708.THD	6	0:23:26	42	10.8	50	10.7	0:24:07	80.4	80.4	84.7	15.3	
19980825_0012.THD	7	0:20:49	42	13.2	50	12.9	0:14:06	80.7	80.7	87.1	12.9	New speed algorithm
19980825_0746.THD	7	0:22:23	13	12.9	8	12.4	0:17:44	73.2	73.2	82.2	17.8	
19980825_1054.THD	8	0:23:46	55	15.1	59	14.1	0:23:01	70.4	70.4	87.7	12.3	Course change
19980825_1329.THD	7	0:20:33	80	13.5	80	13.1	1:06:12	80.5	80.5	87.9	12.1	
19980825_1723.THD	7	0:32:01	78	13.3	84	13.3	0:21:47	89.0	89.0	89.6	10.4	Course change
19980826_0300.THD	5	0:23:15	332	8.2	313	7.5	0:20:32	77.2	77.2	100.4	-0.4	
19980826_1132.THD	7	0:28:14	270	13.2	273	13.4	0:34:58	87.7	87.7	83.9	16.1	New speed algorithm
19980826_1336.THD	6	0:13:03	233	9.9	237	9.8	0:12:01	94.8	94.8	95.9	4.1	
<b>AVERAGES</b>	<b>6</b>	<b>7</b>	<b>8</b>	<b>6,7,8</b>								
Speed	10.5	13.2	15.1									
Corr fuel savings %	8.6	13.9	12.3	11.9								
<b>ECONOMIC IMPACT</b>	<b>Days/yr</b>	<b>Gal/day</b>	<b>Gal/yr</b>	<b>% saved</b>	<b>Ships</b>	<b>Group gal saved/yr</b>						
	300	2800	840000	11.9	12	1203694						
<b>ENVIRON IMPACT</b>												

Analysis by: D MacPherson, HydroComp, Inc.

03-Oct-98

Analysis of test data from USCGC Tampa: 19980824\_1544.THD  
 Matching speed of ship at control setting: 6

Setting 6	SE
15:48:46	16:34:08
16:19:11	17:02:37
0:30:25	0:28:29
71	50
10.86	10.05
301.3	223.2
100.0	74.1
100.0	93.5
	6.5

Start time  
 Finish time  
 Steady-state duration  
 Average course [deg T]  
 Average steady-state speed (kts)  
 Raw average fuel rate [1]  
 Average fuel %  
 Speed-corrected average fuel % [2]  
 Fuel savings %

[1] Raw fuel rates are derived within Smart Engine using initial injector and rack measurement settings. Both Manual and SE figures would shift by a constant after correlation to Max Machinery test results. Percentages would therefore be unaffected.

Figures shown represent total Port + Stbd fuel consumption.

[2] Average fuel % corrected by  $(\text{SpeedManual} / \text{SpeedSE})^3$ .  
 As power (and thus fuel rate) is nominally a function of  $\text{speed}^3$ , this normalizes average fuel % for differences in speed.

Analysis by: D MacPherson, HydroComp, Inc.  
 03-Oct-98

19980824\_1544: Performance Time Series

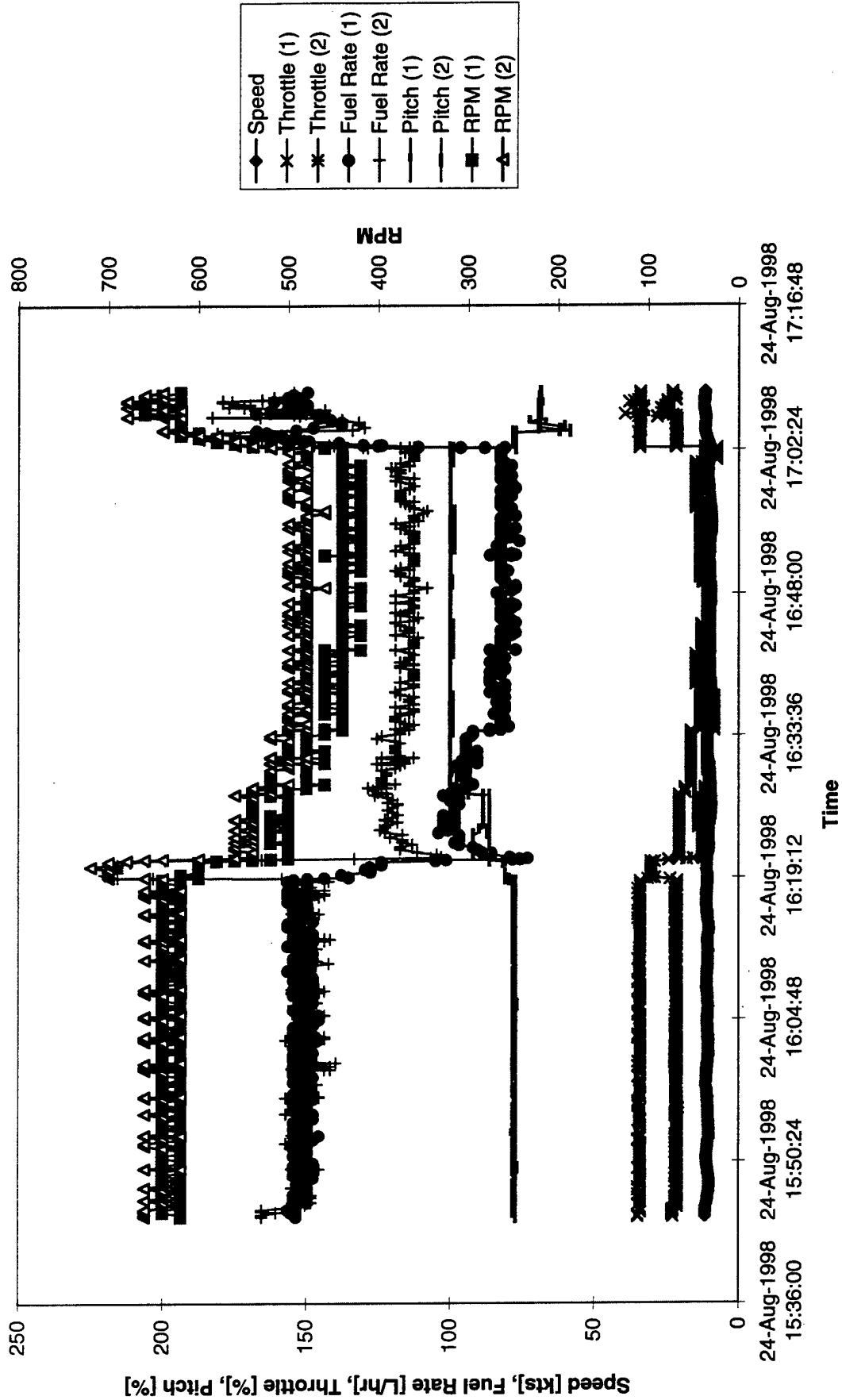

19980824\_1544: Performance Time Series

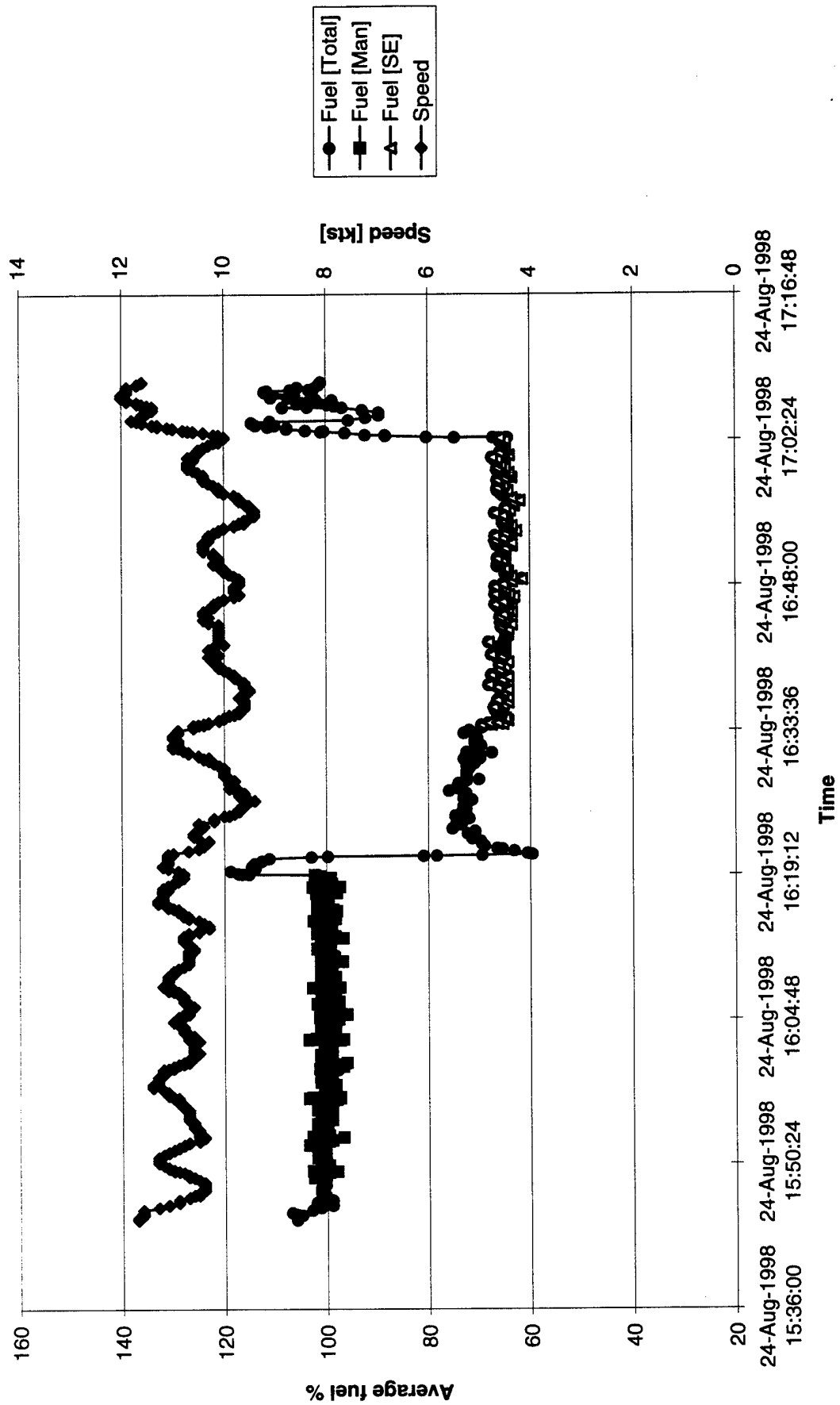

Analysis of test data from USCGC Tampa: **19980824\_1708.THD**  
 Matching speed of ship at control setting: **6**

<b>Setting 6</b>	<b>SE</b>
17:32:26	18:01:25
17:55:52	18:25:32
0:23:26	0:24:07
42	50
10.85	10.66
303.9	244.3
100.0	80.4
100.0	84.7
	<b>15.3</b>

**Start time**  
**Finish time**  
**Steady-state duration**  
**Average course [deg T]**  
**Average steady-state speed (kts)**  
**Raw average fuel rate [1]**  
**Average fuel %**  
**Speed-corrected average fuel % [2]**  
**Fuel savings %**

- [1] Raw fuel rates are derived within Smart Engine using initial injector and rack measurement settings. Both Manual and SE figures would shift by a constant after correlation to Max Machinery test results. Percentages would therefore be unaffected.

Figures shown represent total Port + Stbd fuel consumption.

- [2] Average fuel % corrected by  $(\text{SpeedManual} / \text{SpeedSE})^3$ .  
 As power (and thus fuel rate) is nominally a function of  $\text{speed}^3$ , this normalizes average fuel % for differences in speed.

Analysis by: **D MacPherson, HydroComp, Inc.**  
 03-Oct-98

19980824\_1708: Performance Time Series

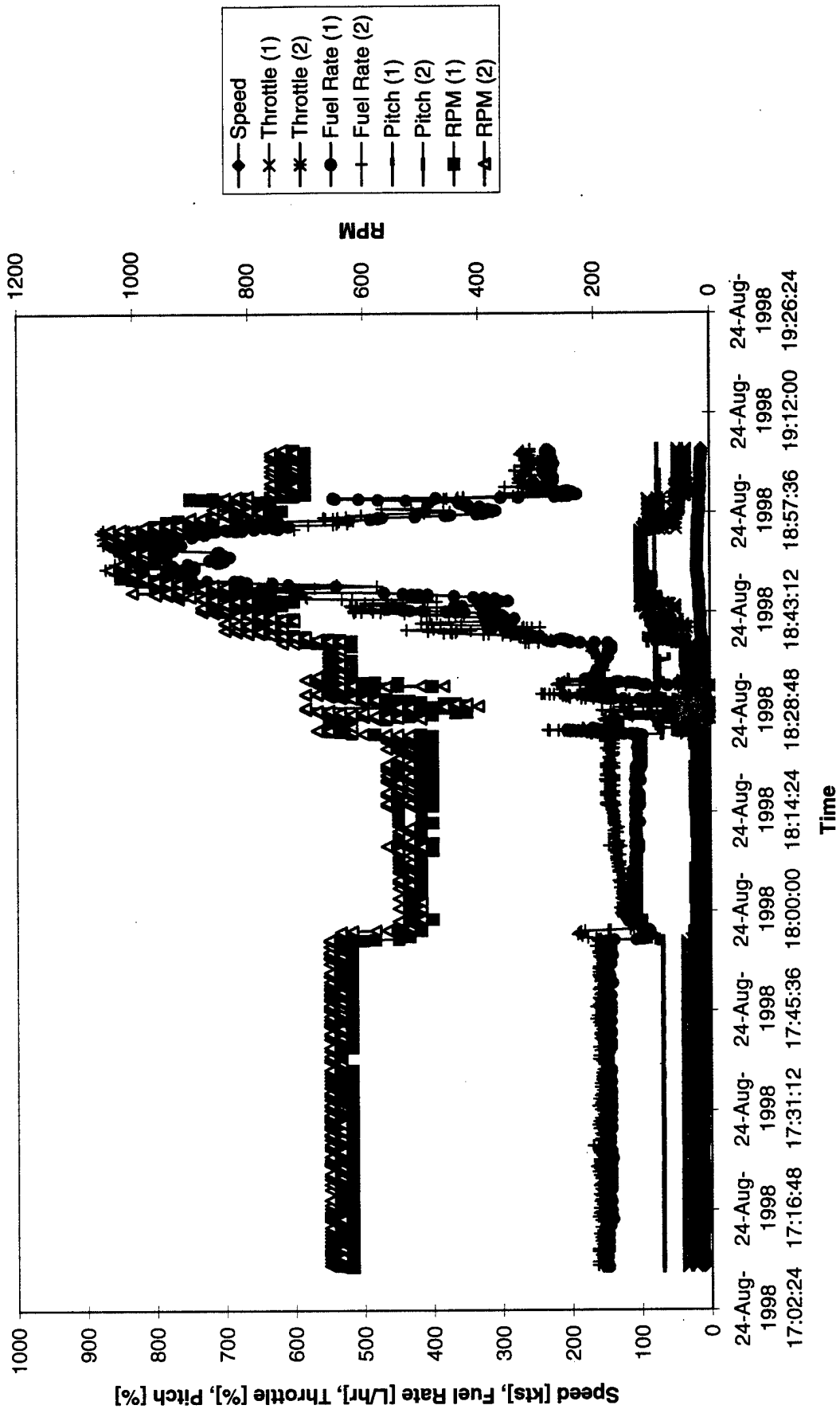

19980825\_1054: Performance Time Series

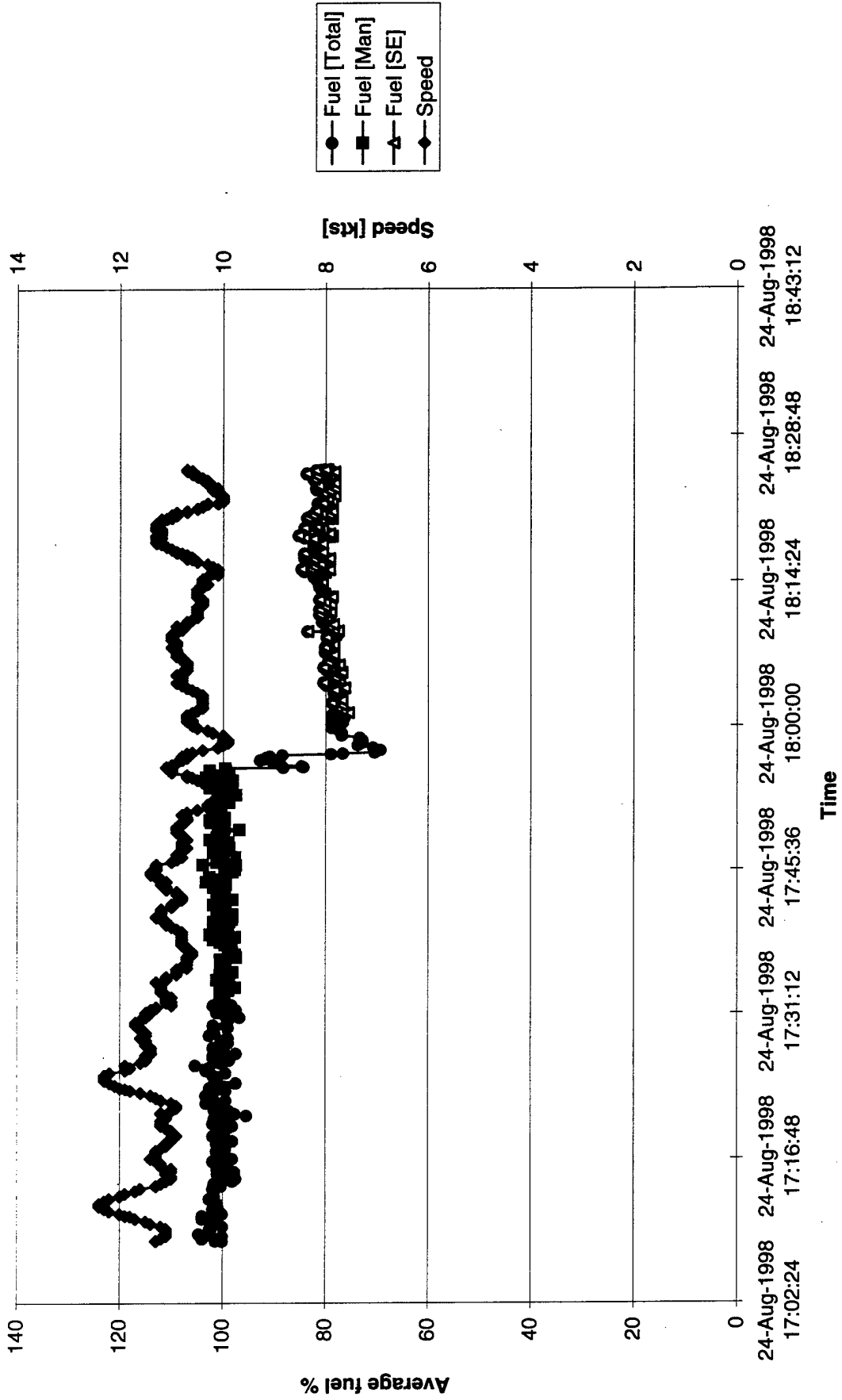

Analysis of test data from USCGC Tampa: 19980825\_0012.THD  
 Matching speed of ship at control setting: 7

Setting 7	SE
0:12:23	1:10:11
0:33:12	1:24:17
0:20:49	0:14:06
42	50
13.23	12.90
501.4	404.8
100.0	80.7
100.0	87.1
	12.9

Start time  
 Finish time  
 Steady-state duration  
 Average course [deg T]  
 Average steady-state speed (kts)  
 Raw average fuel rate [1]  
 Average fuel %  
 Speed-corrected average fuel % [2]  
 Fuel savings %

[1] Raw fuel rates are derived within Smart Engine using initial injector and rack measurement settings. Both Manual and SE figures would shift by a constant after correlation to Max Machinery test results. Percentages would therefore be unaffected.

Figures shown represent total Port + Stbd fuel consumption.

[2] Average fuel % corrected by  $(\text{SpeedManual} / \text{SpeedSE})^3$ .  
 As power (and thus fuel rate) is nominally a function of  $\text{speed}^3$ , this normalizes average fuel % for differences in speed.

Analysis by: D MacPherson, HydroComp, Inc.  
 03-Oct-98

19980825\_0012: Performance Time Series

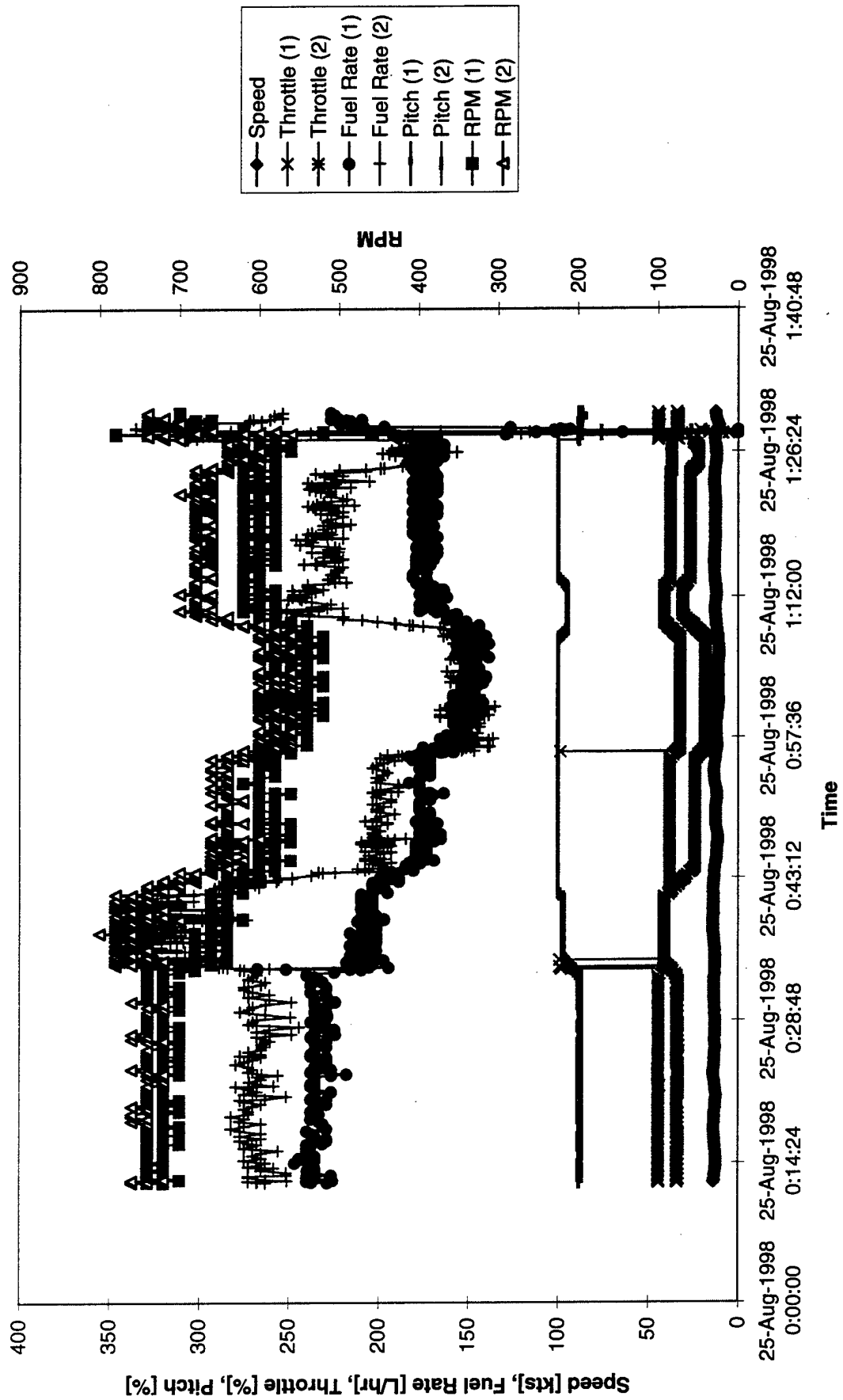

19980825\_0012: Performance Time Series

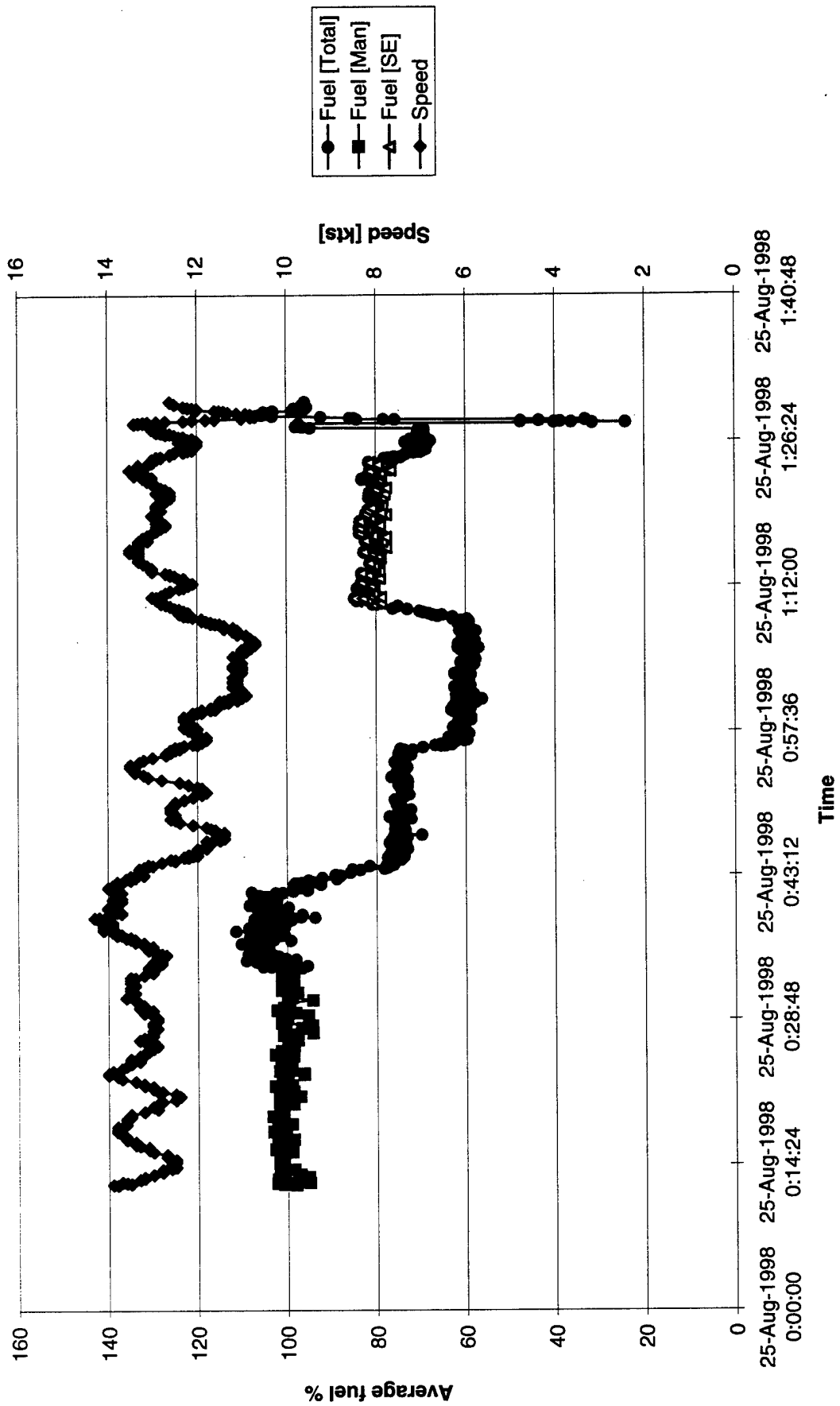

Analysis of test data from USCGC Tampa: 19980825\_0746.THD  
 Matching speed of ship at control setting: 7

Setting 7	SE
7:46:23	8:40:41
8:08:46	8:58:25
0:22:23	0:17:44
13	8
12.86	12.38
555.4	406.6
100.0	73.2
100.0	82.2
	17.8

Start time  
 Finish time  
 Steady-state duration  
 Average course [deg T]  
 Average steady-state speed (kts)  
 Raw average fuel rate [1]  
 Average fuel %  
 Speed-corrected average fuel % [2]  
 Fuel savings %

- [1] Raw fuel rates are derived within Smart Engine using initial injector and rack measurement settings. Both Manual and SE figures would shift by a constant after correlation to Max Machinery test results. Percentages would therefore be unaffected.

Figures shown represent total Port + Stbd fuel consumption.

- [2] Average fuel % corrected by  $(\text{SpeedManual} / \text{SpeedSE})^3$ .  
 As power (and thus fuel rate) is nominally a function of  $\text{speed}^3$ , this normalizes average fuel % for differences in speed.

Analysis by: D MacPherson, HydroComp, Inc.  
 03-Oct-98

19980825\_0746: Performance Time Series

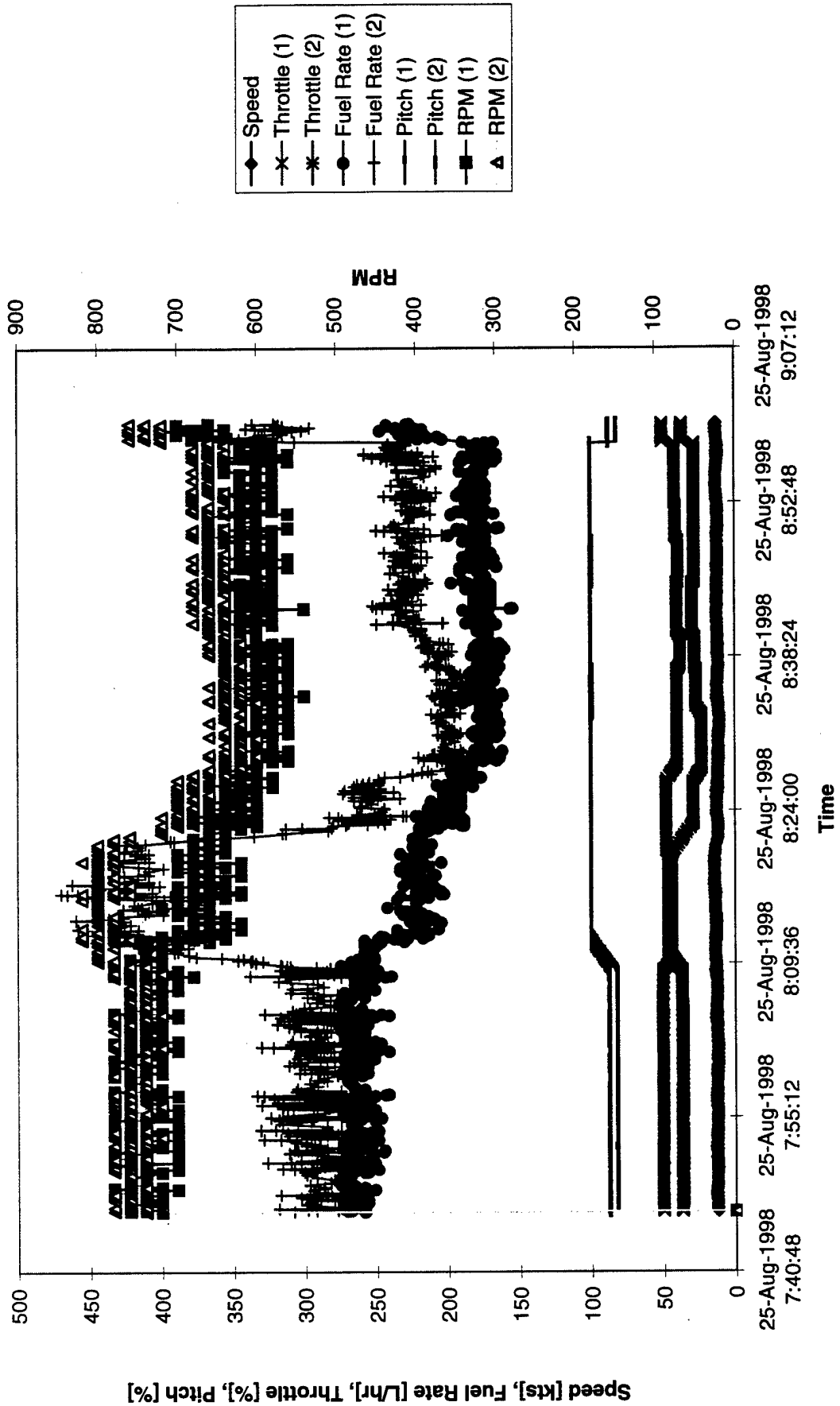

19980825\_0746: Performance Time Series

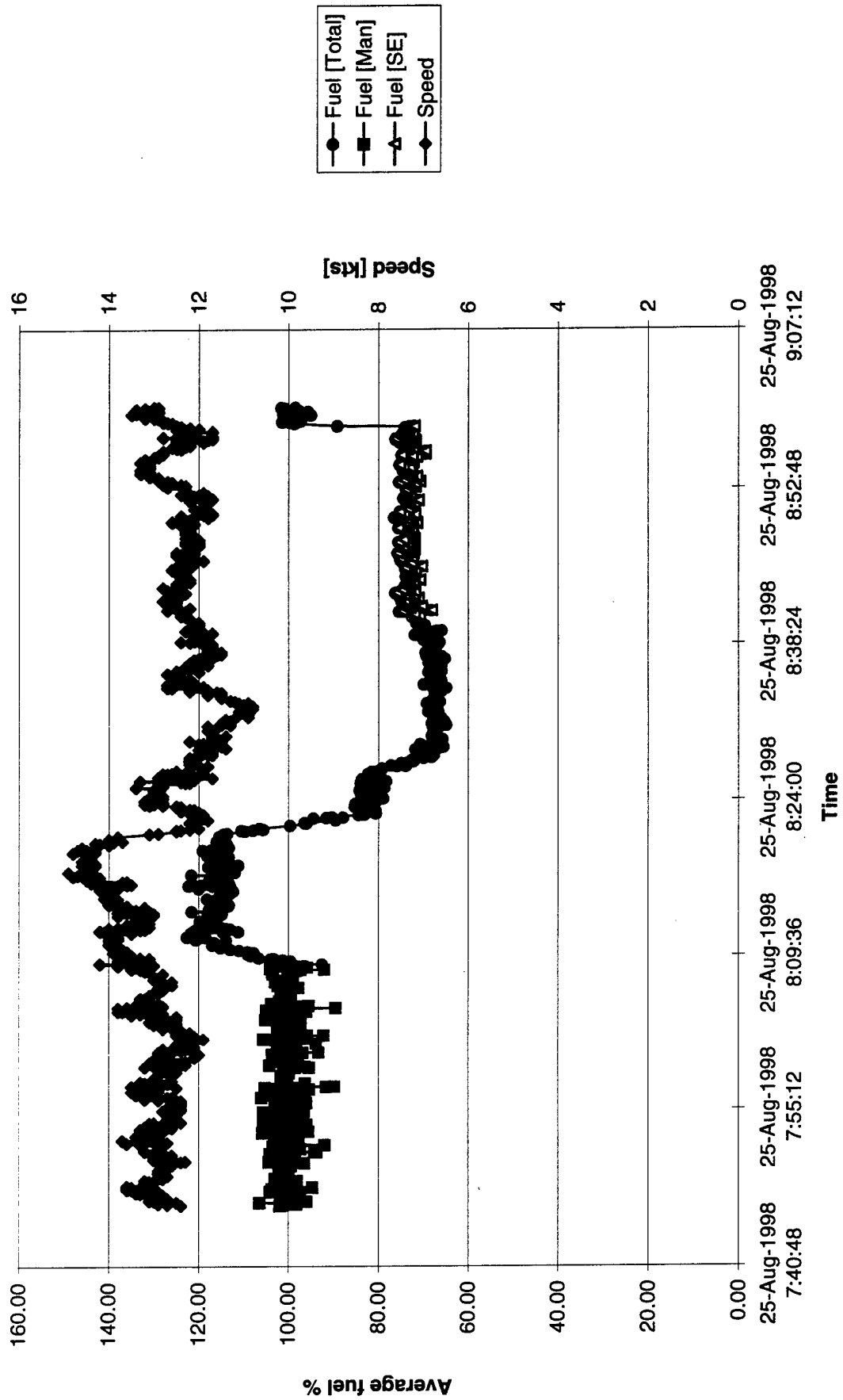

Analysis of test data from USCGC Tampa: 19980825\_1054.TH  
 Matching speed of ship at control setting: 8

Setting 8	SE
10:54:13	11:29:31
11:17:59	11:52:32
0:23:46	0:23:01
55	59
15.14	14.07
840.4	591.8
100.0	70.4
100.0	87.7
	<b>12.3</b>

Start time  
 Finish time  
 Steady-state duration  
 Average course [deg T]  
 Average steady-state speed (kts)  
 Raw average fuel rate [1]  
 Average fuel %  
 Speed-corrected average fuel % [2]  
 Fuel savings %

[1] Raw fuel rates are derived within Smart Engine using initial injector and rack measurement settings. Both Manual and SE figures would shift by a constant after correlation to Max Machinery test results. Percentages would therefore be unaffected.

Figures shown represent total Port + Stbd fuel consumption.

[2] Average fuel % corrected by  $(\text{SpeedManual} / \text{SpeedSE})^3$ .  
 As power (and thus fuel rate) is nominally a function of  $\text{speed}^3$ , this normalizes average fuel % for differences in speed.

Analysis by: D MacPherson, HydroComp, Inc.  
 03-Oct-98

19980825\_1054: Performance Time Series

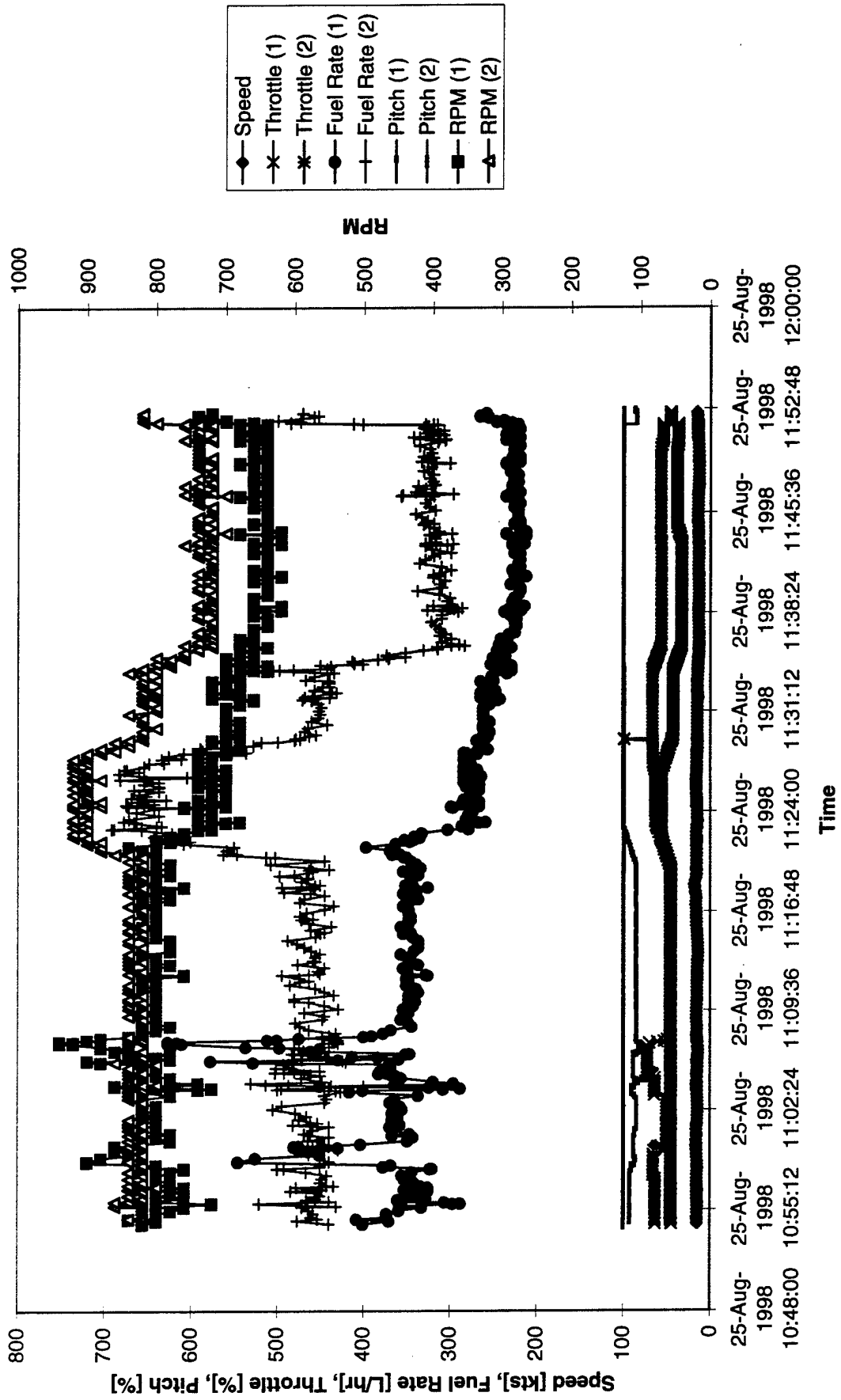

19980825\_1054: Performance Time Series

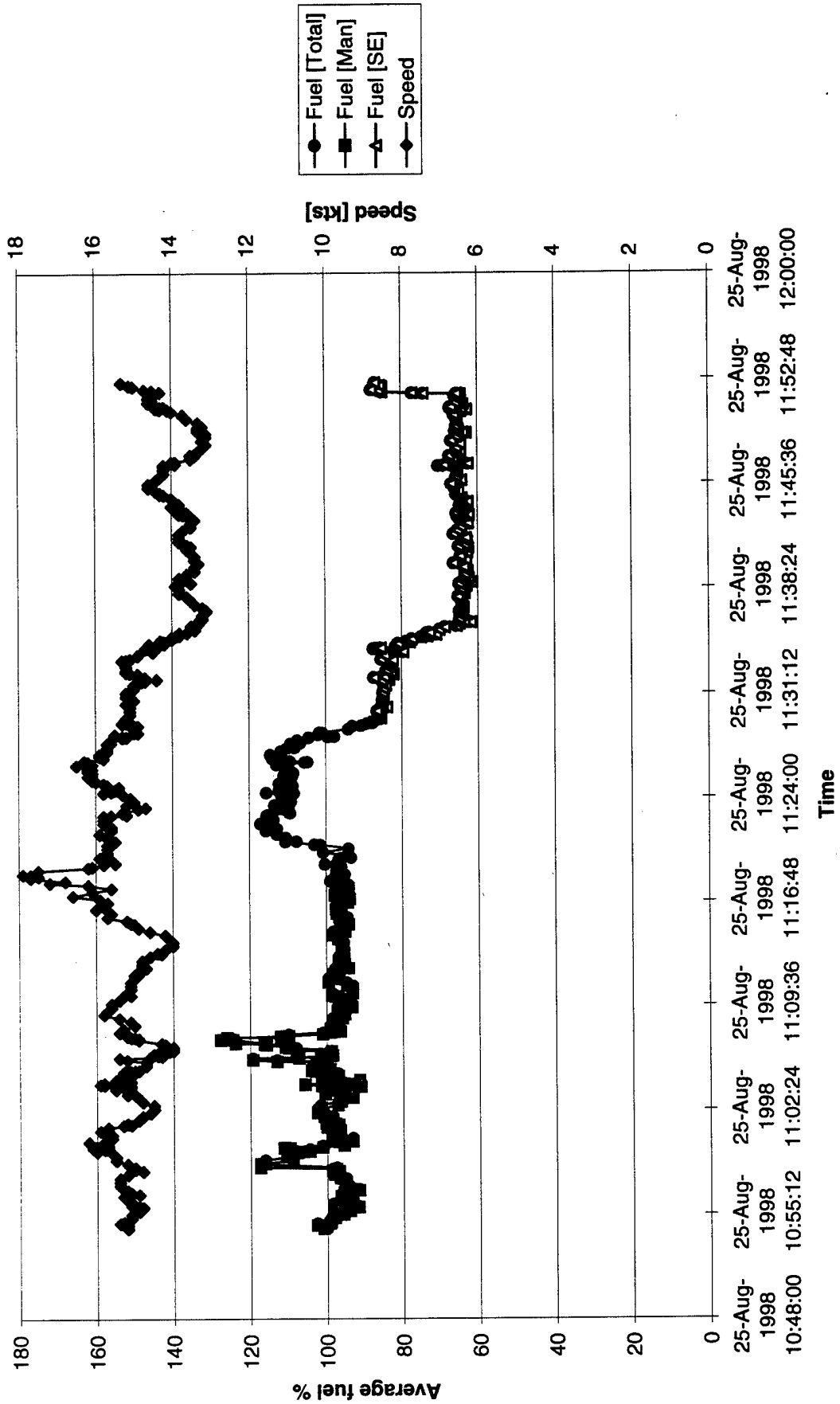

Analysis of test data from USCGC Tampa: 19980825\_1329.THD  
 Matching speed of ship at control setting: 7

Setting 7	SE
13:29:57	14:29:01
13:50:30	15:35:13
0:20:33	1:06:12
80	80
13.47	13.08
507.9	408.6
100.0	80.5
100.0	87.9
	12.1

Start time  
 Finish time  
 Steady-state duration  
 Average course [deg T]  
 Average steady-state speed (kts)  
 Raw average fuel rate [1]  
 Average fuel %  
 Speed-corrected average fuel % [2]  
 Fuel savings %

[1] Raw fuel rates are derived within Smart Engine using initial injector and rack measurement settings. Both Manual and SE figures would shift by a constant after correlation to Max Machinery test results. Percentages would therefore be unaffected.

Figures shown represent total Port + Stbd fuel consumption.

[2] Average fuel % corrected by  $(\text{SpeedManual} / \text{SpeedSE})^3$ .  
 As power (and thus fuel rate) is nominally a function of  $\text{speed}^3$ , this normalizes average fuel % for differences in speed.

Analysis by: D MacPherson, HydroComp, Inc.  
 03-Oct-98

19980825\_1329: Performance Time Series

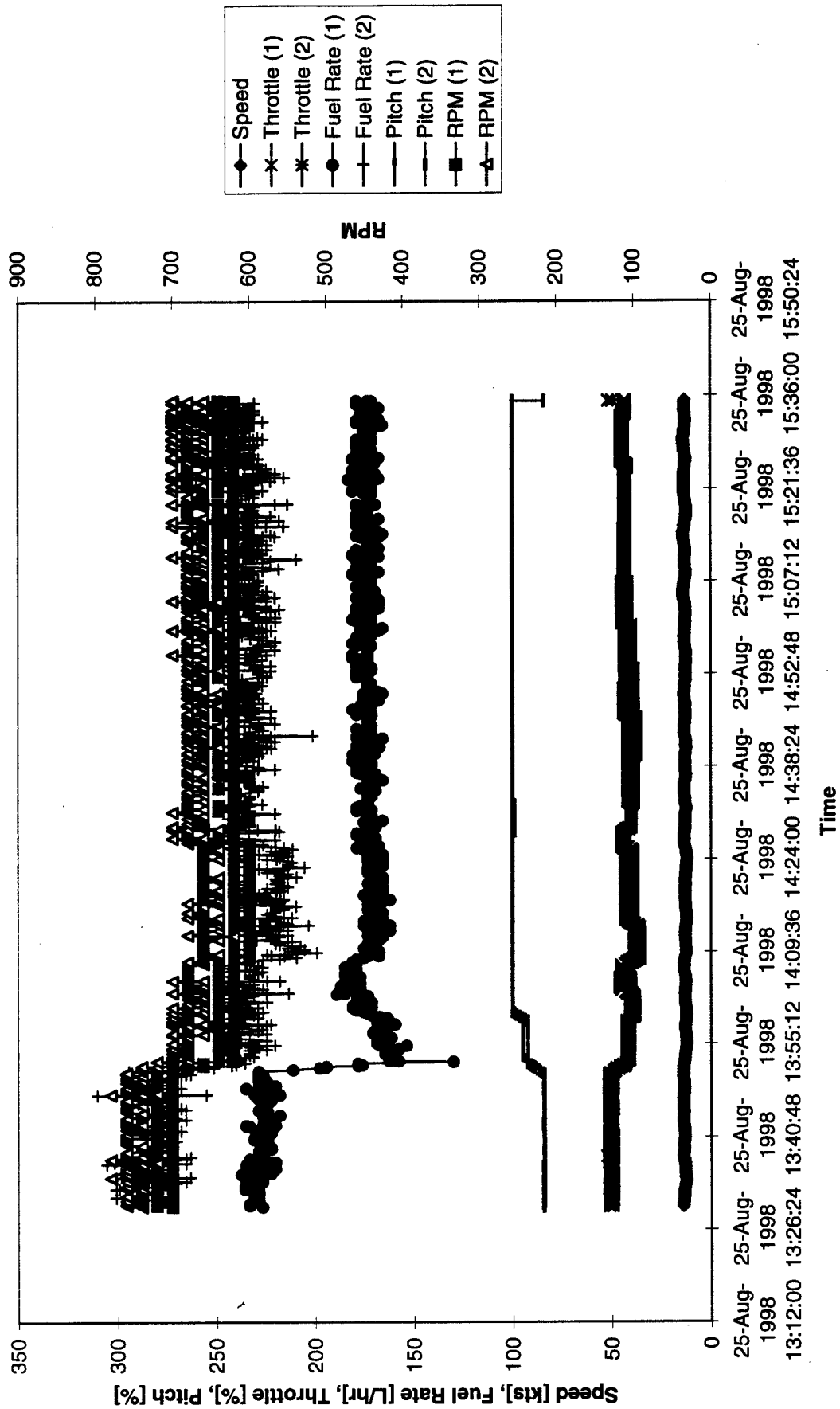

19980825\_1329: Performance Time Series

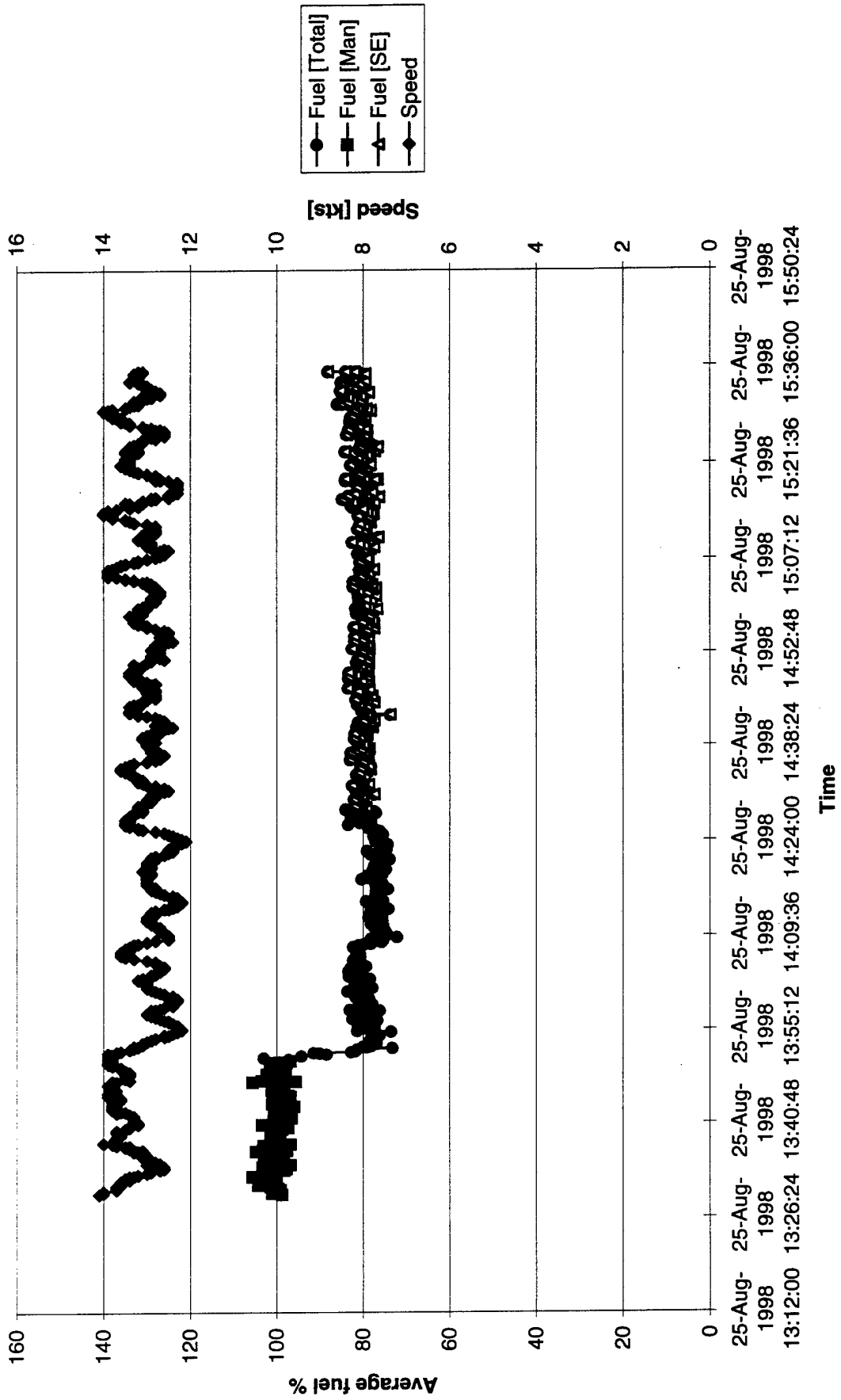

Analysis of test data from USCGC Tampa: 19980825\_1723.THD  
 Matching speed of ship at control setting: 7

Setting 7	SE
17:23:13	18:14:17
17:55:14	18:36:04
0:32:01	0:21:47
78	84
13.33	13.30
496.1	441.7
100.0	89.0
100.0	89.6
	10.4

Start time  
 Finish time  
 Steady-state duration  
 Average course [deg T]  
 Average steady-state speed (kts)  
 Raw average fuel rate [1]  
 Average fuel %  
 Speed-corrected average fuel % [2]  
 Fuel savings %

[1] Raw fuel rates are derived within Smart Engine using initial injector and rack measurement settings. Both Manual and SE figures would shift by a constant after correlation to Max Machinery test results. Percentages would therefore be unaffected.

Figures shown represent total Port + Stbd fuel consumption.

[2] Average fuel % corrected by  $(\text{SpeedManual} / \text{SpeedSE})^3$ .  
 As power (and thus fuel rate) is nominally a function of  $\text{speed}^3$ , this normalizes average fuel % for differences in speed.

Analysis by: D MacPherson, HydroComp, Inc.  
 03-Oct-98

19980825\_1723: Performance Time Series

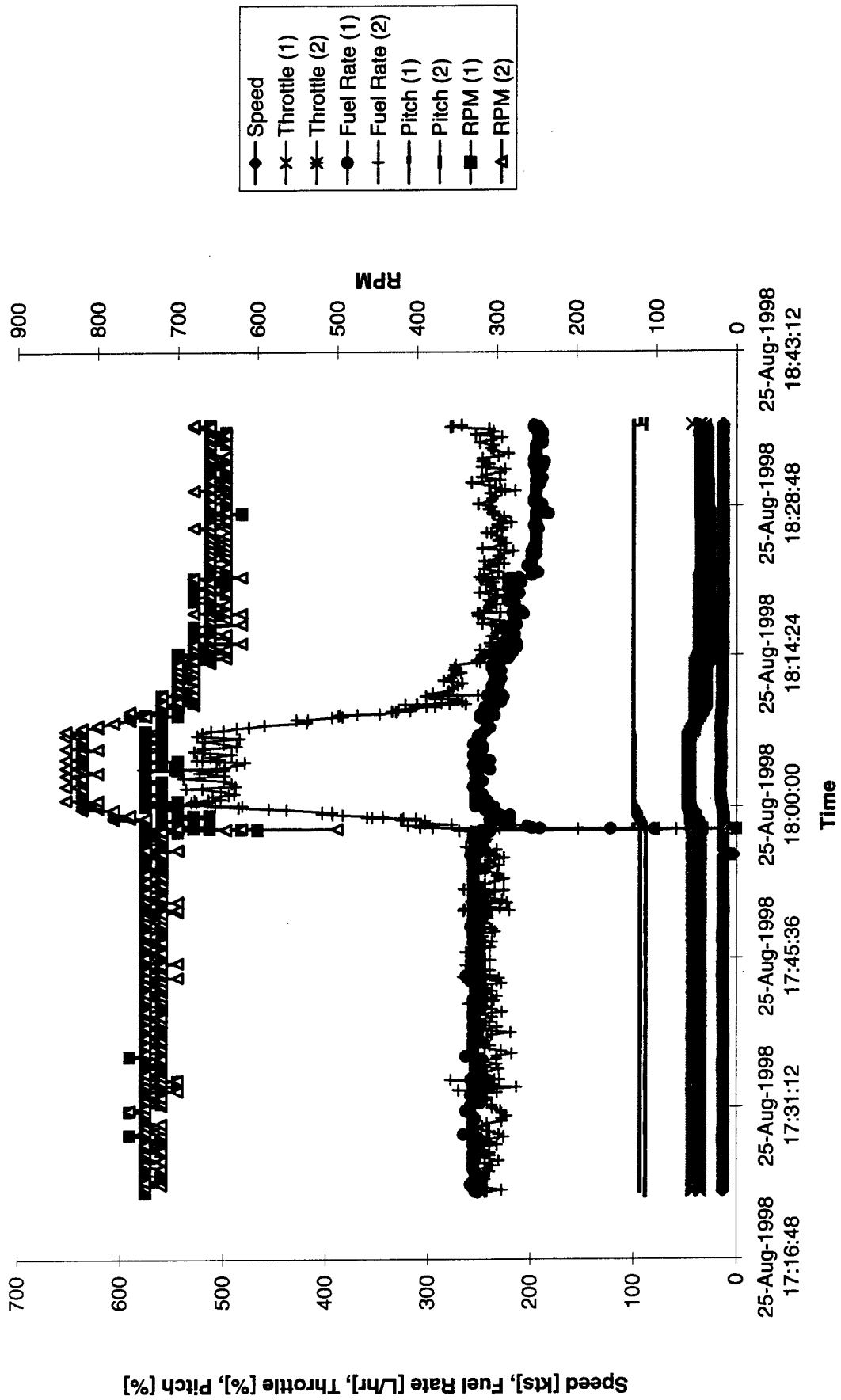

19980825\_1723: Performance Time Series

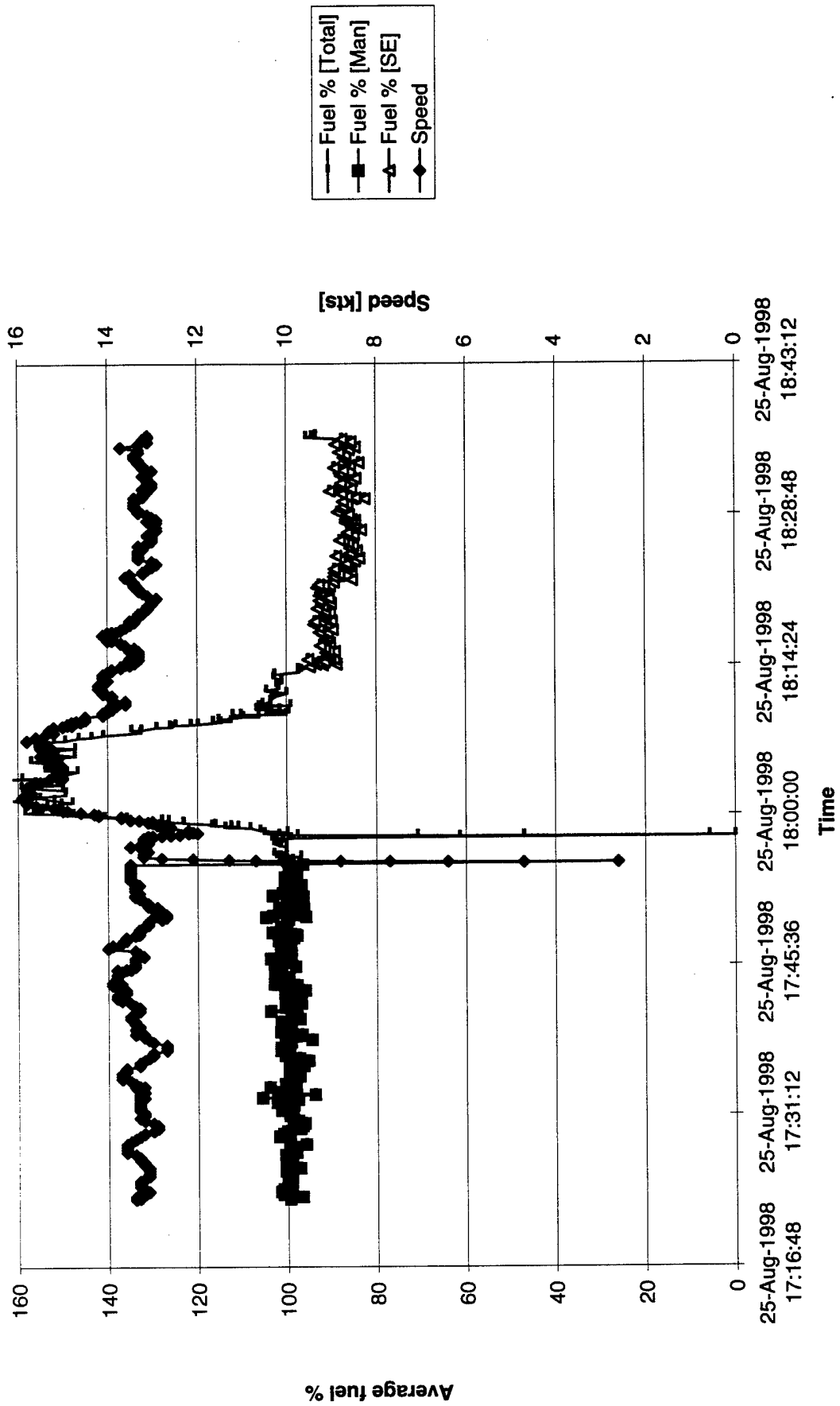

Analysis of test data from USCGC Tampa: 19980826\_0300.THD  
 Matching speed of ship at control setting: 5

Setting 5	SE	
3:00:48	4:08:38	Start time
3:24:03	4:29:10	Finish time
0:23:15	0:20:32	Steady-state duration
332	313	Average course [deg T]
8.24	7.55	Average steady-state speed (kts)
201.1	155.1	Raw average fuel rate [1]
100.0	77.2	Average fuel %
100.0	100.4	Speed-corrected average fuel % [2]
	-0.4	Fuel savings %

[1] Raw fuel rates are derived within Smart Engine using initial injector and rack measurement settings. Both Manual and SE figures would shift by a constant after correlation to Max Machinery test results. Percentages would therefore be unaffected.

Figures shown represent total Port + Stbd fuel consumption.

[2] Average fuel % corrected by  $(\text{SpeedManual} / \text{SpeedSE})^3$ .  
 As power (and thus fuel rate) is nominally a function of  $\text{speed}^3$ , this normalizes average fuel % for differences in speed.

Analysis by: D MacPherson, HydroComp, Inc.  
 03-Oct-98

19980826\_0300: Performance Time Series

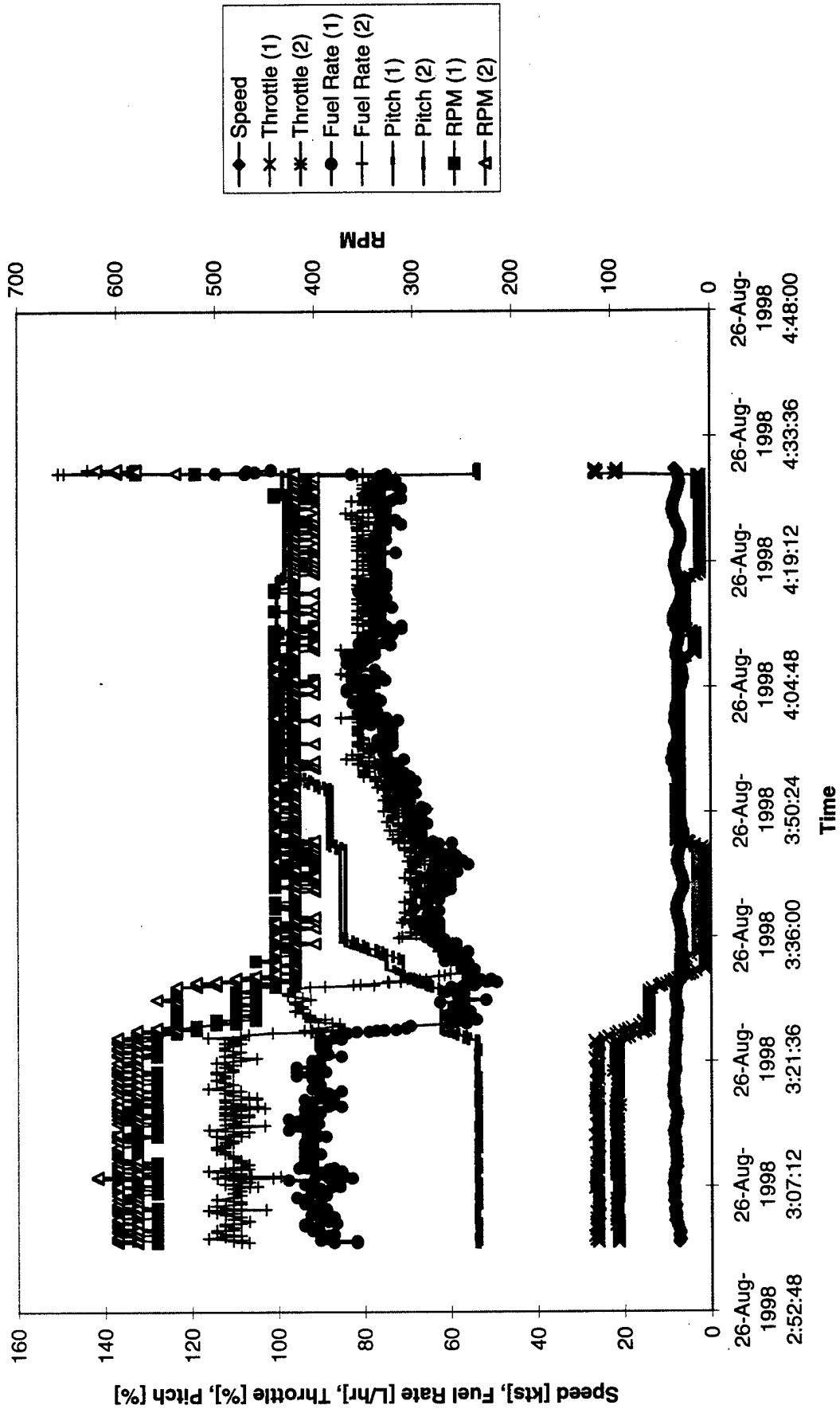

19980825\_1054: Performance Time Series

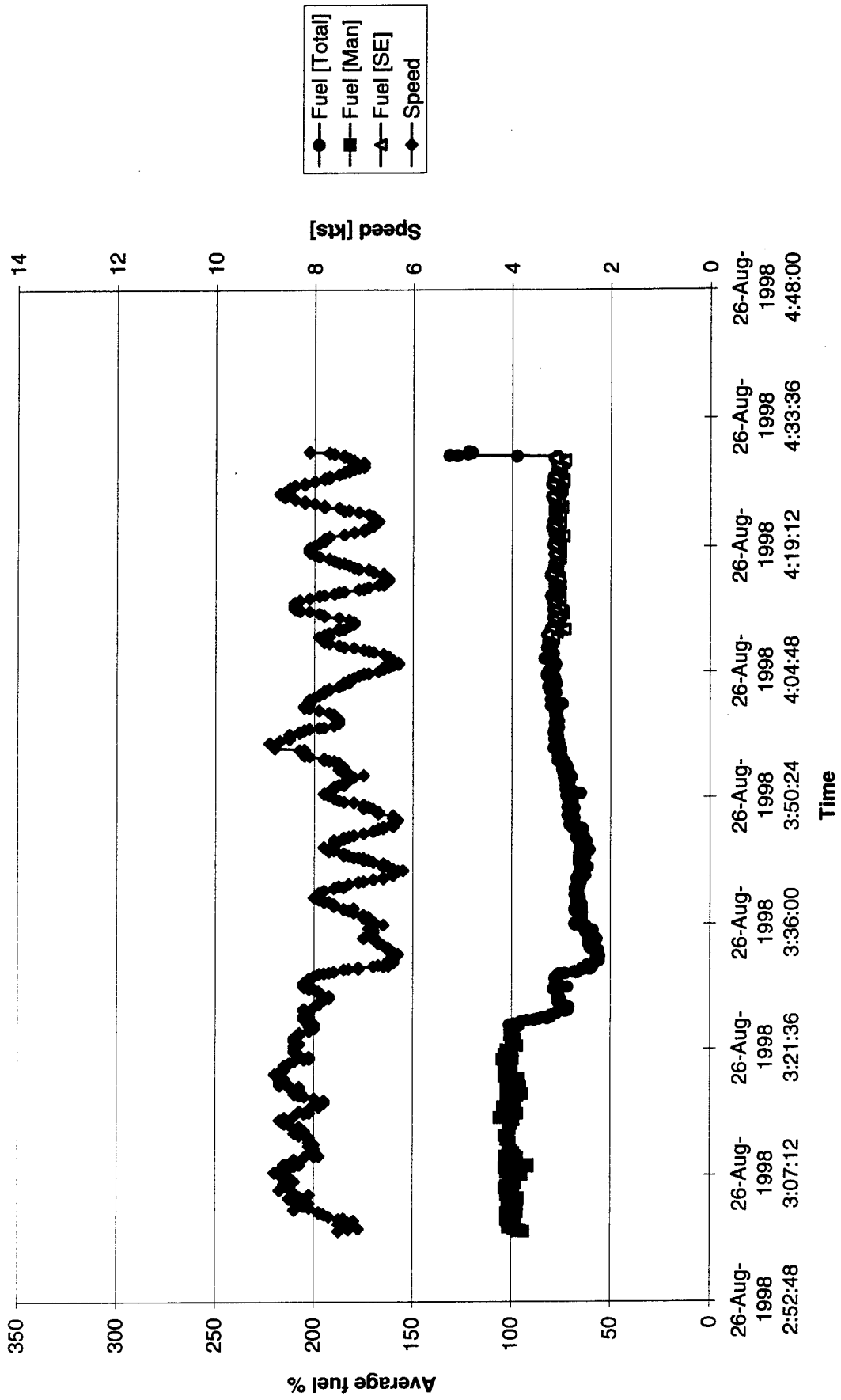

Analysis of test data from USCGC Tampa: 19980826\_1132.THD  
 Matching speed of ship at control setting: 7

Setting 7	SE
11:32:10	12:25:41
12:00:24	13:00:39
0:28:14	0:34:58
270	273
13.20	13.39
489.9	429.6
100.0	87.7
100.0	83.9
	16.1

Start time  
 Finish time  
 Steady-state duration  
 Average course [deg T]  
 Average steady-state speed (kts)  
 Raw average fuel rate [1]  
 Average fuel %  
 Speed-corrected average fuel % [2]  
 Fuel savings %

- [1] Raw fuel rates are derived within Smart Engine using initial injector and rack measurement settings. Both Manual and SE figures would shift by a constant after correlation to Max Machinery test results. Percentages would therefore be unaffected.

Figures shown represent total Port + Stbd fuel consumption.

- [2] Average fuel % corrected by  $(\text{SpeedManual} / \text{SpeedSE})^3$ .  
 As power (and thus fuel rate) is nominally a function of  $\text{speed}^3$ , this normalizes average fuel % for differences in speed.

Analysis by: D MacPherson, HydroComp, Inc.  
 03-Oct-98

19980826\_1132: Performance Time Series

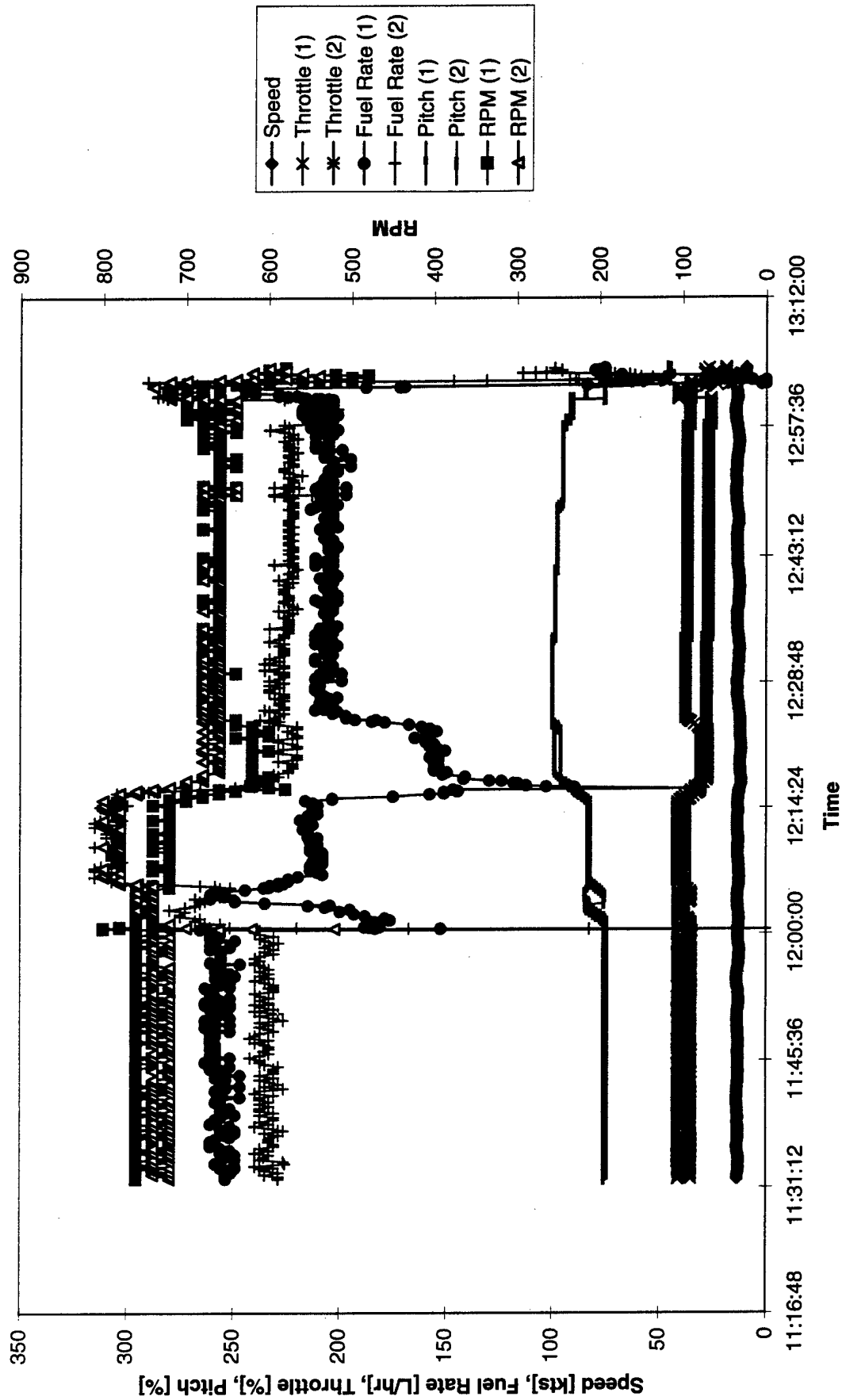

19980826\_1132: Performance Time Series

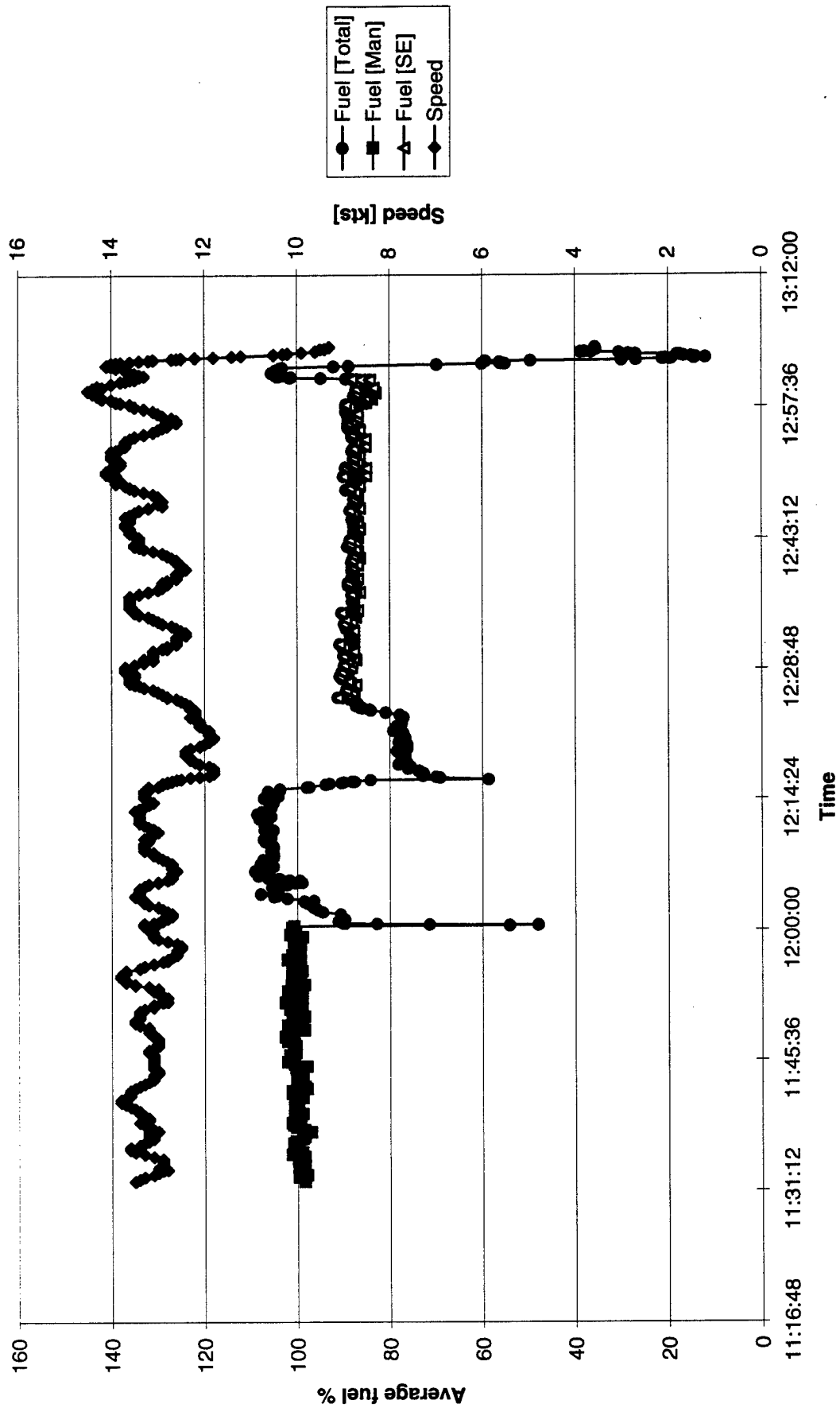

Analysis of test data from USCGC Tampa: 19980826\_1336.TH  
 Matching speed of ship at control setting: 5

Setting 6	SE
13:37:44	14:29:37
13:50:47	14:41:38
0:13:03	0:12:01
233	237
9.86	9.82
233.3	221.1
100.0	94.8
100.0	95.9
	4.1

Start time  
 Finish time  
 Steady-state duration  
 Average course [deg T]  
 Average steady-state speed (kts)  
 Raw average fuel rate [1]  
 Average fuel %  
 Speed-corrected average fuel % [2]  
 Fuel savings %

[1] Raw fuel rates are derived within Smart Engine using initial injector and rack measurement settings. Both Manual and SE figures would shift by a constant after correlation to Max Machinery test results. Percentages would therefore be unaffected.

Figures shown represent total Port + Stbd fuel consumption.

[2] Average fuel % corrected by  $(\text{SpeedManual} / \text{SpeedSE})^3$ .  
 As power (and thus fuel rate) is nominally a function of  $\text{speed}^3$ , this normalizes average fuel % for differences in speed.

Analysis by: D MacPherson, HydroComp, Inc.  
 03-Oct-98

19980826\_1336: Performance Time Series

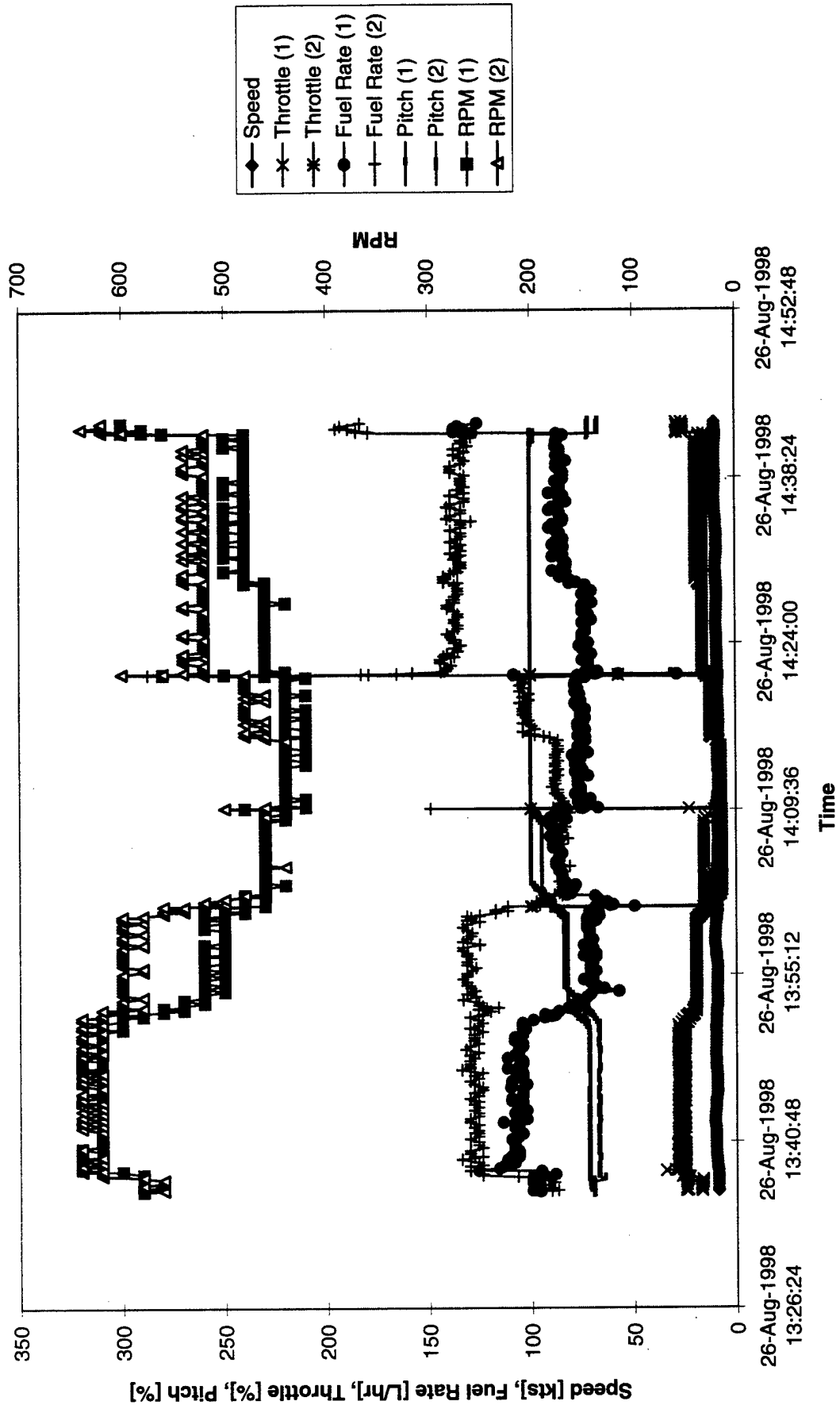

19980825\_1054: Performance Time Series

