

157084

JPRS-CST-85-011

18 April 1985

China Report

SCIENCE AND TECHNOLOGY

DISTRIBUTION STATEMENT A

Approved for Public Release
Distribution Unlimited

~~THIS QUANTITY IS LIMITED~~

19990416 129

FBIS

FOREIGN BROADCAST INFORMATION SERVICE

REPRODUCED BY
NATIONAL TECHNICAL
INFORMATION SERVICE
U.S. DEPARTMENT OF COMMERCE
SPRINGFIELD, VA. 22161

11
127
A07

NOTE

JPRS publications contain information primarily from foreign newspapers, periodicals and books, but also from news agency transmissions and broadcasts. Materials from foreign-language sources are translated; those from English-language sources are transcribed or reprinted, with the original phrasing and other characteristics retained.

Headlines, editorial reports, and material enclosed in brackets [] are supplied by JPRS. Processing indicators such as [Text] or [Excerpt] in the first line of each item, or following the last line of a brief, indicate how the original information was processed. Where no processing indicator is given, the information was summarized or extracted.

Unfamiliar names rendered phonetically or transliterated are enclosed in parentheses. Words or names preceded by a question mark and enclosed in parentheses were not clear in the original but have been supplied as appropriate in context. Other unattributed parenthetical notes within the body of an item originate with the source. Times within items are as given by source.

The contents of this publication in no way represent the policies, views or attitudes of the U.S. Government.

PROCUREMENT OF PUBLICATIONS

JPRS publications may be ordered from the National Technical Information Service, Springfield, Virginia 22161. In ordering, it is recommended that the JPRS number, title, date and author, if applicable, of publication be cited.

Current JPRS publications are announced in Government Reports Announcements issued semi-monthly by the National Technical Information Service, and are listed in the Monthly Catalog of U.S. Government Publications issued by the Superintendent of Documents, U.S. Government Printing Office, Washington, D.C. 20402.

Correspondence pertaining to matters other than procurement may be addressed to Joint Publications Research Service, 1000 North Glebe Road, Arlington, Virginia 22201.

18 April 1985

CHINA REPORT

SCIENCE AND TECHNOLOGY

CONTENTS

PEOPLE'S REPUBLIC OF CHINA

NATIONAL DEVELOPMENTS

Relation Between S&T, Open Door Policy Stressed (KEXUEXUE YU KEXUE JISHU GUANLI, No 10, 12 Oct 84)	1
Issues of Continuing Education Discussed (Chen Tongzhu; KEXUEXUE YU KEXUE JISHU GUANLI, No 10, 12 Oct 84)	4
Inclusion of Continuing Education in National Plans Discussed (Shao Lie; KEXUEXUE YU KEXUE JISHU GUANLI, No 10, 12 Oct 84)	8
Issues in Enterprise Research Discussed (Cai Rukui; KEXUEXUE YU KEXUE JISHU GUANLI, No 10, 12 Oct 84)	11
Computer Trade Meeting Sets Development Course (Ding Shiwu, Gu Honghong; XINHUA Domestic Service, 18 Mar 85)	21
Briefs Zhejiang Computer Company	22

APPLIED SCIENCES

On Coupling Factors of Explosion (Zhang Shaoquan; DIQIU WULI XUEBAO, No 6, Nov 84)	23
Improved Gonda's Circuit Described (Li Changhou, et al.; DIANZI KEXUE JISHU, No 10, 10 Oct 84)	38
Using a Single-Board Computer To Maintain Constant Voltage, Current Sources (Li Zigang, Yang Yongzhi; DIANZI KEXUE JISHU, No 10, 10 Oct 84)	44

PRC Officially Names Antarctic Lake 'Xihu'
 (Zhu Youdi, Giu Weimin; XINHUA Domestic Service, 27 Feb 85) 50

Briefs

Fujian Computer Technology	51
Shandong Computer Technology	51
Zhejiang Wastepaper	51
Chinese Character Computers	51
Chinese-Character Software Produced	51
Jilin Utilization of Microcomputers	52

ENVIRONMENTAL QUALITY

Conference on Environmental Protection in Beijing Convened (Wang Shuqi; HUANJING BAOHU, No 5, 1984)	53
Research on Agricultural Environmental Protection Discussed (Jiang Tianzhong; NONGYE HUANJING, Aug 84)	56
Maintenance of Balanced Ecosystem for Agricultural Growth Urged (Wei Shuangfeng; HUANJING BAOHU, No 5, 1984)	60
Quality Assurance of Air Monitoring Discussed (Cheng Xiaowu; HUANJING BAOHU, No 8, Aug 84)	66
Beijing Traffic Noise Reduction Methods Discussed (Li Bingguang, Chen Dingchu; HUANJING BAOHU, No 5, 1984).	72
Environmental Forecast in Shanghai Discussed (Yang Xianzhi, Wu Lindi; HUANJING BAOHU, No 6, Jun 84) ..	81
'Sansheng' Indicator System Examined (Li Jinchang; HUANJING BAOHU, No 5, 1984)	87
Water Quality of Gezhouba Area Discussed (Wan Xiantao; HUANJING BAOHU, No 6, Jun 84)	94
Effects of Industrial Pollution on a North China Lake Explored (Wang Zhuangjing; HUANJING BAOHU, No 5, 1984)	98

ABSTRACTS

CHEMISTRY

HUAXUE SHIJI /CHEMICAL REAGENTS/ No 5, 28 Oct 84	105
ZHONGHUA YUFANG YIXUE ZAZHI /CHINESE JOURNAL OF PREVENTIVE MEDICINE/ No 6, 25 Nov 84	106

ELECTRONICS

DIANZI XUEBAO /ACTA ELECTRONICA SINICA/ No 6, Nov 84	107
--	-----

GEOPHYSICS

CHANGCHUN DIZHI XUEYUAN XUEBAO /JOURNAL OF CHANGCHUN COLLEGE
OF GEOLOGY/ No 1, 1984 110

MATHEMATICS

YINGYONG SHUXUE XUEBAO /ACTA MATHEMATICAE APPLICATAE SINICA/,
No 3, Jul 84 111

MECHANICS

YINGYONG SHUXUE HE LIXUE /APPLIED MATHEMATICS AND MECHANICS/,
No 4, Jul 84 113

YINGYONG SHUXUE HE LIXUE /APPLIED MATHEMATICS AND MECHANICS/,
No 6, Nov 84 115

MEDICINE

JIEFANGJUN YIXUE ZAZHI /MEDICAL JOURNAL OF CHINESE PEOPLE'S
LIBERATION ARMY/ No 6, 20 Dec 84 119

PSYCHIATRY

ZHONGHUA SHENJING JINGSHENKE ZAZHI /CHINESE JOURNAL OF NEUROLOGY
AND PSYCHIATRY/ No 6, 23 Dec 84 122

NATIONAL DEVELOPMENTS

RELATION BETWEEN S&T, OPEN DOOR POLICY STRESSED

Tianjin KEXUEXUE YU KEXUE JISHU GUANLI [SCIENTIOLOGY AND MANAGEMENT OF SCIENCE AND TECHNOLOGY] in Chinese No 10, 12 Oct 84 pp 11-12

[Article by KEXUEXUE YU JISHU GUANLI's commentator: "The Relation Between S&T and the Open Door Policy"]

[Text] In the work conference on scientific research units sponsored by the Tianjin City Science Committee, a very significant question was raised. This was the relation between the systematic reform on the S&T frontline and the open door policy. This is a very good as well as a significant question which deserves general attention and further study.

Comrade [Zhao] Ziyang pointed out that systematic reform and the open door policy are two important events on the current economic frontline. The relation between them is obviously very close.

To Begin With, We Should Study and Understand the Influence and Requirements Which the Open Door Policy Has on the Systematic Reform of S&T. The goal of our open door policy is to introduce advanced and appropriate technology and experiences in scientific management, to utilize foreign funds and to make them serve the acceleration of the construction of modernization. During this activity, scientific research units are responsible for making scientific suggestions on what advanced and appropriate technologies to introduce. They are responsible for providing help and support to bring the introduced technologies into full play. They are especially responsible for carrying out "introspective" studies on the introduced technologies in order to redevelop and recreate new achievements which "originate from the introduced technologies but are better than them." Introducing advanced and appropriate technologies will also accelerate our development in production. This, in turn, will necessarily pose more demands on S&T and will encourage scientific research units and scientists and technologists in carrying out higher level and more difficult studies. Besides, introducing advanced technology will bring new pressure upon scientific research units. Research which is of a lower quality, is redundant or very costly and of little benefit will have more difficulty existing. Scientists and technologists who are conservative or whose knowledge is out-of-date will have problems adapting to the demands of the new situation. In the open door policy, thanks to the introduction of the advanced and appropriate technologies and experiences in scientific management, the "vertical comparison method" and the

regarding scientific research achievements from "one's own history," old customs in which one can be easily satisfied by "some progress" will be smashed. Instead, people will have to carry out "horizontal comparison" of oneself with "the reality" of other people and see clearly one's own deficiencies. Thus, the pressure of the advancing times will form a sense of immediacy which will "force people to wake up suddenly." All this tells us that the open door policy has great influence on and demands a great deal from the reform of the S&T system. Both the influences and demands are positive ones. Currently, the pace of the open door policy in S&T has become not bigger, but smaller. We should consider the "open door" as a long-term or even permanent policy. Only when we have adequate understanding of the policy, can we think more enthusiastically about how we should adapt the reform of the S&T system to the new situation.

Secondly, We Should Recognize and Study the Function and Significance of the Reform of the S&T System on Open Door Policy. The S&T system indicates the overall structural condition of the social business system of S&T and the relation between its component parts. The content of the S&T system includes the management of different levels; the arrangement of research organizations; the handling of the leading and guiding relationship among vertical and horizontal organizations as well as their sharing and cooperative relationship; the determination of each organization's responsibility, power and interest as well as its style and method of management. The nature of the S&T system is reflected in the comprehensive social structure of the relations of production and the superstructure of S&T affairs. It has great influence on the productivity of S&T. The purpose of the reform of the S&T system is to reverse the function of the relation of production and of the superstructure which impedes the development of S&T and makes these relations vigorously promote the smooth development of S&T affairs. Criteria to be examined in an S&T system include: whether it can continuously increase the enthusiasm and efficiency of scientists and technologists and the economic and social benefits of S&T work. Our reform of the S&T system is to realize this goal and to achieve better standards. Therefore, it is absolutely foreseeable that the reform in the S&T system will gear, as is necessary and inevitable, the activities of scientific research units to society, to the world and to the future; that the open door policy will be expanded and strengthened both internally and externally; that the communication of S&T information between home and abroad will be developed, thereby making more and deeper and broader contributions, in the development of production, the promotion of the economy and the development of the international market. All this explains that the reform in the S&T system will bring about the development of the open door policy.

As can be seen, the reform in the frontline of the S&T system is also related to the open door policy. They effect and help each other. The better integration of the two will have an important effect on the construction of our nation's socialist material and spiritual civilization.

Currently, there is an important issue confronting people in the S&T and economic fields. That is, they should recognize the inner relationship between them and correct the misleading "each does things in his own way" style.

They should, through practice, integrate systematic reform with the open door policy and do both well, thereby providing experiences and being nurtured by reform of the S&T system. While practicing the open door policy and coordinating and promoting the development of the open door policy they must reform the S&T system.

An important task confronting contemporary researchers in scientiology is to explain profoundly, through theories and objective laws, the above-mentioned issue which arises from reality and to improve the rational knowledge of people involved in the actual work and to provide them with a theoretical basis and guiding ideology. They should, scientifically, explain the content, nature, characteristics and function of the S&T system and the relation between the S&T system and the economic system. They should, from the objective laws of the history of economics as well as social development, explain the function and significance of the open door policy. They should, from the developmental laws of S&T and economy, explain the necessary relationship between the S&T system and the open door policy. They should study foreign experiences, lessons and the like in relation to the S&T system and the open door policy.

On studying the relationship between the reform of the S&T system and the open door policy, we should not confine ourselves to these two. We should integrate it with studies in policies and systems relevant to financing, loan on credit, revenue, foreign trade, personnel, etc. We should explain, in theories, what policies and legal measures we have to have in order to promote the coordinated development of the reform in the S&T system and the open door policy; what necessary measures we have to adopt in financing, loan on credit, revenue, foreign trade, personnel, etc.; what possible negative problems we have to prevent and suitable policies for dealing with them, etc.

In general, we must carry out systematic, historical, comparative and predictive studies in systematic reform, the open door policy and their relationship with each other. We must avoid an isolated, one-sided and static method of studying.

As we mentioned at the beginning of the article, systematic reform and the open door policy are two important issues in the current economic frontline. They are directly related to the quality and speed of the construction of the four modernizations in our country. Seeing that the S&T system is an integral part of the economic system, it affects the progress of technology even more directly. Therefore, good management of the relationship between the systematic reform in S&T and the open door policy will also affect the "key" of the four modernizations more directly. Managers and researchers on the economic and S&T frontline should work hand in hand. They should, on the one hand, use Marxist economic and S&T theories to guide the practice. On the other hand, they should raise experiences to the level of theories so as to enrich and develop theories and make them contribute to the construction of our modernization.

12369

CSO: 4008/157

NATIONAL DEVELOPMENTS

ISSUES OF CONTINUING EDUCATION DISCUSSED

Tianjin KEXUEXUE YU KEXUE JISHU GUANLI [SCIENTIOLOGY AND MANAGEMENT OF SCIENCE AND TECHNOLOGY] in Chinese No 10, 12 Oct 84 pp 35-36

[Article by Chen Tongzhu [7115 0681 2691], the Navy Logistics Department:
"On Continuing Education for Scientists and Technicians"]

[Text] By equipping our scientists and technologists with the latest S&T, we can make them stand on the shoulders of international science. We can reduce the gap which exists between our country and the advanced countries in S&T. Besides, since the starting-point of the construction of our four modernizations will be a little higher and the development will be faster, we will be able to catch up with the international revolution in technology. The training work should start out from the needs of S&T tasks and specialized construction. It should be closely integrated with realities in scientific research. We should, according to current and long-term needs, acquire knowledge about whatever we are doing and make up whatever is deficient. By so doing, we can make use of what we have learned, integrate learning closely with work, integrate the production of achievements with talents and strive for a success in both achievements and talents. On-the-job education should begin with the practical conditions of various levels of scientists and technologists. Requirements should be based on specific conditions which we should treat differently and plan comprehensively. We should seek to raise the general level and lay special stress on some key points.

1. High-Ranked Scientists and Technologists. The main point is to create necessary conditions for them so that they can, through studying their field intensively, doing advanced studies outside, going abroad on investigative tours, participating in conferences, training graduate students and instructing middle- and basic-level scientists and technologists, improve their business and theoretical level. They can increase their basic theoretical and professional knowledge of their own and related subjects. They can have access to the latest experimental techniques, be familiar with S&T trends at home and abroad, be good leaders of their own profession and be good at understanding other subjects. They should participate in, or guide, the tackling of technical problems in key projects in their field. They should also conscientiously summarize their experiences by writing specialized research work.

2. Middle-Ranked Scientists and Technologists. The main point is, with the guidance of high-ranked scientists and technologists, to improve their ability in analyzing and solving problems basically through independent study, as well as through practice, academic discussion and going out to do advanced studies. Thus, they can understand the new S&T urgently needed in their own profession, make up and renew basic theories and knowledge essential to their profession, understand the present situation and the developmental trend of related S&T at home and abroad, master essential research methods and experimental techniques and improve their independent work ability. We should, according to the demands for the development of current new technology, pay close attention to the training of these scientists and technologists so that they can master, as soon as possible, the new technologies and theories in the field of electronic computers, learn to use computers and handle several commonly used computer languages. Those who are not yet good enough in foreign language should work hard so as to be able to read books and periodicals in their field in foreign languages. They should integrate literature and document research with scientific research work while writing their theses and work summaries.

3. Basic-Level Scientists and Technologists. The main point is that these scientists and technologists, under the guidance of their high and middle-leveled colleagues, undertake basic training in basic theories, professional knowledge, experimental skills and foreign languages by studying when being released from work or studying during leisure time and by the integration of practical work experience. They should work conscientiously to handle basic methods and experiment techniques in S&T and thus proceed to be professional. They should learn to be able to write S&T work reports, experimental reports as well as to be able to translate foreign language materials of their profession.

4. Technicians. The main points for these people include obtaining basic knowledge essential for doing experiments in their field, strengthening their basic technical training in doing experiments, mastering experimental techniques which they use frequently, learning to observe experimental phenomena and record them accurately. Those who have not received college or university education can systematically make up for what they lack in basic knowledge and professional techniques.

5. S&T Management Cadres. The main point is to help them to master knowledge in S&T management so that they can keep abreast of relevant new S&T and the developmental trend of related S&T at home and abroad. They should learn relevant theories such as S&T policies, scientiology, S&T management, training of S&T personnel, forecasting, systems engineering, etc. They should manage theories in S&T organization and management systematically, master their own business and be acquainted with one foreign language. S&T management is also science which must be strengthened in order to do the management of S&T well. This is even more important because the S&T managers we have currently were all originally technicians or administrative cadres. They do not have professional training, they do not know what scientific management is, nor do they know how to manage. As a result, there is a big gap between S&T management and what S&T development demands. Therefore, we should pay

close attention to the training of S&T managers while training scientists and technologists.

One decisive factor in the development of S&T is talent. The training of S&T cadres has to be in line with the developmental trend of modern S&T. We should do a good job in forecasting talent demand as well as short- and long-term planning. Each year we should work out training plans for the year and issue them together with S&T assignment plans. The plans should include definite requirements. They should be planned in an overall way so that the training can be carried out directionally and everybody can have access to it. We should also try our best to make the plan, organization and policies practicable. Those who are included in the training plan will be tested and assessed at the end of a year and their achievements will be listed in their personnel business record. Theses and reports should be examined and given appropriate comments. Awards should be issued for well-written theses and reports. Middle-aged scientists and technologists are the mainstay of current S&T work. They also have the historic responsibility of linking up the past and the present. In order to help them to meet the requirements of the new technological revolution and reach the leadership level of their field as soon as possible, we should formulate key training projects in a planned manner. We should start the entire training work from reality and make adjustments when necessary. We should open wide the road for people to study and adopt different forms to suit different people. Here are some specific forms:

1. Short-Term Training Class in a Unit. Mainly suitable for one unit or several professions in acquiring common knowledge, this form is primarily aimed at new knowledge urgently needed for tasks or assignments or basic technologies and techniques essential for the developments of the times. Among its characteristics are that it is geared to the needs of the professions, it is highly practical, it is concentrated in time, people can make use of what they have learned immediately, it yields results very fast, etc. Professional training in such skills as microprocessors, computer languages, applied mathematics, probability theories as well as foreign languages, scientific management, scientific prediction, etc. can be carried out by using this form.
2. Planned Advanced Studies in Colleges or Universities. For scientists and technologists, an effective way to renew and improve their knowledge is by doing advanced studies in colleges or universities. With abundant teachers and rapid renewal of their courses, colleges and universities are important bases for scientists and technologists to renew their knowledge. We should, in a planned manner, select and send some middle-aged and young scientists, technologists and professional technicians to colleges and universities where they can learn new knowledge in their profession. With systematic training, we can purposefully produce some professional people.
3. Learning While Being Partly Released from Work and Learning by Self in Spare Time. In this form, S&T cadres are organized to carry out integration of practical work with constant business studying without leaving their work. Also in this form, a business studying system is established.

People are educated through correspondence, television, radio, sparetime universities, self-learning, etc. In so doing, it does not affect people's work and the broad S&T cadres can make full use of their spare time to learn knowledge needed for their work. This is an important way which each scientist and technologist can use for his own life education. It is cheap and flexible; everybody can do it.

4. Develop Academic Activities by Making Use of Existing Institutes. This is another effective way of on-the-job education. The various kinds of institutes we have in our country are where professional people from all specialized and scientific fields gather. The institutes' academic discussions are most up-to-date in knowledge, rich in contents and broad in vision. They react relatively quickly to domestic and foreign trends in S&T. All these facts make the institutes good places for training scientists and technologists and preventing their knowledge from becoming out-of-date. We should make good use of the abundant talents of the institutes. Whenever the institutes organize some academic exchange activities and different kinds of study groups, each unit should enthusiastically select some people to participate. Besides trying to propose some papers and reports for exchange, the units should also bring back messages from the academic discussion of the institutes and introduce them to a certain number of people. Thus, many people will benefit from the person who has participated in the discussion. Within a unit, S&T research and seminars and editing of papers should be held frequently so as to promote brisk academic thinking.

5. Going Abroad for Advanced Study or Investigation and Bringing Up Graduate Students and Training Key S&T Members. This is a good opportunity for improving the technical level of a profession. Qualified and capable scientists and technologists of high and medium rank should all participate in these two jobs.

12369

CSO: 4008/157

NATIONAL DEVELOPMENTS

INCLUSION OF CONTINUING EDUCATION IN NATIONAL PLANS DISCUSSED

Tianjin KEXUEXUE YU KEXUE JISHU GUANLI [SCIENTIOLOGY AND MANAGEMENT OF SCIENCE AND TECHNOLOGY] in Chinese No 10, 12 Oct 84 p 32

[Article by Shao Lei [0508 7191]: "The Inclusion of Continuing Education in National Plans"]

[Text] To solve the rejuvenization of the knowledge of on-the-job scientists and technologists is not a petty thing. On the contrary, it is an important matter which directly concerns the improvement of technology and realizes the promotion of economy. Many industrially developed countries, while depending on S&T for the promotion of their economy, pay very close attention to the continuing education of on-the-job scientists and technologists. Besides, as the level of S&T improves, their content of continuing education improves too. For example 170,000 out of the 1,207,000 engineers hired in the United States in 1979 received continuing education costing \$2 billion, with 80 percent of the expenses being paid by the companies. In 1971 the French National Assembly passed "Continuing Education Codes" and practiced "Advanced Study Leave System." According to the codes, each production unit should provide over 1.1 percent of its wages for engineers to do advanced studies. In 1982, the expenses paid by French companies, factories and mines throughout the country was about 15 billion francs. In 1977, the Soviet Union stipulated in its laws that engineers should leave their jobs for advanced studies once every 5 years. Currently, the Soviet Union has 93 advanced study academies aimed at continuing education. Each year 20 to 25 percent of its scientists and technologists go there to study. While depending on S&T for the promotion of economic development, we should also carry out on-the-job continuing education for our scientists and technologists at the appropriate time so as to meet the needs of economic construction and development.

How are we to solve well the rejuvenization of the knowledge of on-the-job scientists and technologists? We have done a survey and consulted the opinions of concerned departments. The conclusion of the survey is: the fundamental way out is to develop continuing education vigorously. Continuing education means the rejuvenization and supplementation of the knowledge of scientists and technologists who have received college education and above; it is the extension and supplementation of higher education.

Many of the scientists and technologists from production, scientific research and educational departments with whom we have come into contact all strongly

advocate the vigorous development of continuing education. They demand that a sound continuing education system be established so as to satisfy the needs of scientists and technologists while working on scientific research and production and that continuing education be included in the national plans as soon as possible. They believe that in so doing there will be many advantages:

I. It Is Advantageous to the Opening Up of New Technological Fields and to Catching Up with the Pace of the International Technical Revolution. Today, as S&T are advancing by leaps and bounds, there is hardly any branch of learning whose development is not influenced and conditioned by it. Especially noteworthy is the appearance of a series of major subject systems, such as nuclear engineering, aviation, communication techniques, etc. which are eliminating, day by day, the traditional boundaries existing between different subjects. As a result, they integrate the different subjects with one another and solve the major problems in S&T. As the teachers and students of continuing education all come from different places, each field is indeed the assembling of talents and the grand exchange of information.

II. It Is Advantageous to the Shortening of the Training Period for Talents. Generally speaking, a college graduate, after 4 to 5 years of study at school, needs 1 to 2 years of on-the-job training to be competent at his job. On-the-job scientists and technologists not only have some knowledge in basic theories but also have relatively abundant practical experiences. When tackling a new technology or undertaking the rejuvenization of knowledge in their field, they have to study it from the very beginning. The studying, which takes as long as a year or half a year or as short as a few months, will enable them to meet the needs of the development in scientific research and production. By so doing, the time needed for training talents and opening up new technological fields can be greatly decreased.

III. It Is Advantageous to Improving the Technologies of Scientific Research and Production Departments. Today, the scientists and technologists of some of our production departments, especially medium and small enterprises, are still using old traditional methods and techniques in production. Quite a few of these scientists and technologists are unfamiliar with the new knowledge in their own field and have no idea about relevant technologies. Particularly, they know very little about the knowledge on the margins of established professions. As a result, the popularization of new technology and new achievements is delayed and their efficiency is affected. The development of continuing education will improve this situation.

IV. It Has a Very Significant Bearing on the Reform in the Engineering Departments of Colleges. Although many factors cause the slow development of our scientific research and production, a very important one is the out-of-date content of engineering education which directly affects scientific research and production. Most of the contents of our engineering courses are still those of the early 1950's. The talents we have are poor in their professional adaptability, on the one hand, and weak in their basic knowledge, on the other. They are very incapable of directly acquiring new knowledge. When the problems in continuing education are worked out, it

will not only make up for the deficiency in engineering education in colleges, but will also promote its reform.

The development of continuing education will rejuvenate the knowledge of on-the-job scientists and technologists. This is advantageous to the development of scientific research and production.

Continuing education was first started in France and the United States. Although it has developed relatively late in our country, quite a few units have gained some experiences in it. Provided that our leaders pay attention to this, it is absolutely possible for us to fully utilize this way and make it serve the development of our scientific research and production.

12369

CSO: 4008/157

NATIONAL DEVELOPMENTS

ISSUES IN ENTERPRISE RESEARCH DISCUSSED

Tianjin KEXUEXUE YU KEXUE JISHU GUANLI [SCIENTIOLOGY AND MANAGEMENT OF SCIENCE AND TECHNOLOGY] in Chinese No 10, 12 Oct 84 pp 18-22

[Article by Cai Rukui [5591 3067 7608]: "Scientific and Technological Information Research Institute in Beijing City Discusses the Improvement of Enterprise Research"]

[Text] I. Enterprise Research Is the Chief Organizational Form of Research and Development

In the last few decades, S&T has become a decisive force in the development of the social economy, an important part in the development of the social economy and the chief decisive factor in the development of the economy and the improvement of productivity. Therefore, advanced countries all pay a lot of attention to their development in S&T, particularly R&D. In order to utilize S&T and promote economic development, these countries all concentrate their strength on R&D. The investment which the United States, Japan, England, etc. have made in R&D is more than one-half of their funding of scientific research. This is because when we want to transform S&T into direct productive force, we have to utilize the achievements in basic and applied studies in production by using new technologies, materials and equipment which have been materialized through R&D. Only thus can there be economic benefits. Therefore, R&D is the only way which we can take to transform scientific research achievements into productive force.

Our country is now at the stage of adjusting and reforming our national economy. Generally speaking, our scientific research is still at the stage of introducing, digesting and transforming a great deal of advanced foreign technologies and has not yet reached the stage of independent research. Viewed from international as well as domestic conditions, we can absolutely make use of the available foreign scientific research achievements and, after R&D, utilize them in production as soon as possible. Thus, we can achieve the best economic benefits within the shortest time and enable our country to catch up with the level of the advanced countries. For this reason, under our current situation, we should conscientiously strengthen our work in R&D.

As we all know, enterprise research, research organization and university research are the traditional organizational forms of research. Each of these

has its function: factories and enterprises which start out from enterprises have a larger proportion of R&D; universities generally concentrate on basic as well as applied research; research organizations are between enterprises and universities. The following chart is the proportion of Japan's factories and enterprises, research organizations and universities engaged in research (1977). (see Chart 1)

Chart 1.

	<u>Basic Research (percent)</u>	<u>Applied Research (percent)</u>	<u>R&D (percent)</u>
Factories, enterprises, etc.	4.7	19.6	75.9
Research organizations	17.4	34.7	47.9
Universities, etc.	57.4	37.0	5.7

In the last few decades, as a result of the unprecedented expansion of the scale of scientific research and the strengthening of science's function as a direct productive force, the comprehensive pattern of the organization of scientific activities (such as the science-production joint company, the scientific center, etc.) has played a more and more important role in the system of scientific organization. The structure of various kinds of traditional scientific research organization is also changing. Enterprise research, however, has always been an important organization form in countries undertaking developmental research. Judging from domestic and foreign experience, R&D, be it product or be it technological development, should concentrate on factories and enterprises. This is because the fundamental task of enterprises is to find how to produce more high-quality products with lower cost and less materials so as to satisfy the increasing demands of society. Products are the focus of the activities of enterprise. Enterprises which do not have products have lost their vitality. New technologies are the means of competition. Enterprises which do not have new technologies have lost their competitiveness. In order to keep on producing new products and improving the quality of the products, we cannot do without S&T work, nor can we do without R&D. This is why some of the chief industrialized advanced countries in the world pay very close attention to R&D in their companies and enterprises in order to achieve technological superiority in intense competition and obtain high profits. Some of the largest enterprises in the world invest generally 1 to 8 percent of their total sales in industrial research. The proportion of investment for electronic apparatuses, meters, computers, etc. which are developing faster, however, is higher; for iron and steel industries it is lower and for the manufacturing of machine tools it is medium. The following is a chart of the United States, Japan and the FRG's investment in some of their enterprises: (see Chart 2)

Chart 2.

<u>Enterprises</u>	<u>Year</u>	<u>Fund for Develop- mental Research (\$10,000)</u>	<u>Percentage of investment in research (percent)</u>
U.S. Steel Co	1974	3,700	0.4
Japan's five major steel companies (average)	1973	9,700	0.8
U.S. Dupont Chemical Co	1975	33,600	4.6
Bayer Chemical Co of the FRG	1975	41,000	5.6
U.S. General Electric Co	1978	127,000	6.5
Siemens Electrical Co of the FRG	1978	DM23 billion	8.0
Japan's Hitachi Co	1972	17,400	4.0
U.S. Singer Sewing Machine Co	1967	4,100	2.6
UK Lucas Industries Co	1977	5,107	3.4
U.S. Boeing Airplane Co	1978	27,610	5
U.S. Metal Container Co	1967	2,000	1.5

Enterprise research is the main organizational form of R&D because it has the following advantages: 1) The selection of subject is closely integrated with production and sales. Generally the subject includes some key technical problems during production or some new varieties demanded in the market. Research, production and sales are integrated and leadership is centralized and so the disadvantages of the separation of research from production and marketing are conquered. 2) The factories have experimental and productive means by which they can readily examine their new products and technologies and decide whether to adopt them or not. 3) Seeing that people involved in the research are familiar with the technological equipment in the factories and have practical experiences, the technological plans they have are more realistic. The problems are solved according to the conditions by using whatever is available. 4) Research funding is worked out more easily. Thanks to the above-mentioned advantages, enterprise research has always been an organizational form with relatively strong vitality which has completely played its role in R&D.

II. Scientific Researchers and Scientific Research Fund Make Up Low Percentages of Total Personnel and Total Expenditures--the Most Important Characteristic in Our Weak Enterprise Research

Scientific research work has always been a weak link in our country's factories and enterprises. Throughout the country there are over 300,000 enterprises, mostly differing in their conditions of production techniques, in their level of management, in their varieties of products and in their needs of technical transformation. To improve and transform their techniques, they cannot simply depend on the few scientific research organizations which we have. They must depend on their own scientific research. This is the only way which can accelerate the renewal of their products, resulting in their continuous progress in techniques; incessantly increase their competence; immediately adapt to the demand in the market and increase their economic benefits.

The following chart, made from incomplete statistics on the United States, Japan, the Soviet Union and China shows the number of factories and enterprises which have developed scientific research (in fact, have set up scientific research organizations), their number of enterprise researchers and their enterprise research fund. (See Chart 3) The three aspects basically and roughly reflect the capability and level of enterprise research and its position in the general scientific research system. Through relative analyses, the problems existing in our enterprise research are clarified.

Chart 3.

<u>Nation</u>	<u>Number of Factories and Enterprises Engaged in Scientific Research and Its Percentage in the Total Enterprises</u>	<u>Percentage of Enterprise Researchers in the National Scientific Researchers</u>	<u>Percentage of Enterprise Research Investment in the Total Scientific Research Investment</u>
United States	12,000 4% (1)	60 (2)	68.6 (3)
Japan	17,620 8.8% (1971)(4)	62 (1977) (5)	65.2 (1977) (6)
Soviet Union	1,800 (1966)(7) 38% (8)	7.7 (1969) (2)	5 (1977) (7)
China	about 2,800 (1980) 0.8% (9)	about 17.5 (1980)	

- Notes: (1) The Formation and Characteristics of the Network of U.S. Scientific Organization, p 80,
(2) Scientiology and Information on Technological Management, 1981, No 15, p 61,
(3) Interior Discussions, No 421, National Science Committee's Scientific and Technological Policy Bureau,
(4) pp 28-29,
(5) The Japanese White Paper on Science and Technology, p 302,
(6) Ibid, p 111,
(7) The Scientific Policies of the Soviet Union, p 406,
(8) Calculated at the 46,587 enterprises in 1962, see the Scientific Policies of Soviet Union, p 407,
(9) Calculated at the 350,000 enterprises existing in our nation.

On the examination of the chart listed above, we can see that U.S. and Japanese scientific researchers who are engaged in enterprise research make up over 60 percent of each nation's total scientific researchers. This explains that these two countries are both very strong in enterprise research and have great developmental power. In Japan, there are 154,000 researchers working in companies and enterprises (1978). That is, for every 10,000 staff and workers, 240 are researchers. The Soviet Union, in strong contrast to Japan has only 7.7 percent of its researchers working in factories or enterprises, while 55.7 percent work in scientific research organizations. This is an important factor which causes the Soviet Union to lag behind the United States in the integration of science with production. Although the proportion of our enterprise researchers is higher than that of the Soviet Union,

(17.5 percent), it is about 2-fold less than the United States or Japan. The proportion of our researchers in factories and enterprises, research organizations and colleges and universities is small on both ends and large in between: small proportions in factories and colleges and universities and large in research organizations. Listed below are the proportion of scientific researchers in the three kinds of organizations in the United States, Japan, Soviet Union and our country.

Chart 4.

<u>Nation</u>	<u>Factories and Enterprises (percent)</u>	<u>Research Organizations (percent)</u>	<u>Universities (percent)</u>
United States (1980) (1)	68.5	11.3	15.4
Japan (1978) (2)	56.3	10.2	33.5
Soviet Union (1969) (3)	7.7	55.7	37
China (1980)	17.5	81.6	0.9

- Notes: (1) 1982, 9E21,
 (2) The Japanese White Paper on Science and Technology, p 124,
 (3) Scientiology and Information on Scientific and Technological Management, 1981, No 15, p 61.

Although the proportion of factories and enterprises developing scientific research is different from one country to another in total enterprises, the proportion is generally not very large. The largest is less than 10 percent of the total enterprises. This fact explains that among the factories and enterprises throughout the world, only a small number have set up research organizations. This is because R&D work takes a great deal of time and requires enterprises to be economically well enough to undertake this task which does not always yield results right away. In other words, this task places demands on the financial abilities, profits and management techniques of enterprises. Most enterprises today cannot meet these demands. Secondly, from the standpoint of increasing efficiency, scientific research funds and researchers are better used centrally than dispersedly. Since the resources for scientific research funding cannot meet the ever-increasing demand for scientific research funding, most of the scientific research work of the leading capitalist countries' enterprises are becoming centralized. Some medium and small companies either carry out their common tasks cooperatively or ask large companies for help. The high centralization of scientific research enables large companies to concentrate their scientific research force on major S&T problems and improve their production and labor productivity. The following is a chart on some leading capitalist countries' concentration of enterprise research. In the United States, 300 companies spend 92 percent of the enterprise research funding. In Switzerland, the concentration is even higher, reaching 96.5 percent.

Chart 5.

No of Companies	4	20	100	200	300
Percentages of Scientific Research Funds Taken					
Nation					
United States	22.6	57.0	82.0	89.0	92.0
England	25.6	47.2	69.5	75.0	77.0
FRG	20.9	48.2	81.0	91.2	95.6
Switzerland	33.2	54.2	85.4	90.0	96.5
Japan	11.9	31.2	52.1	63.1	71.4

In our country, factories which have established scientific research organizations make up only a small percentage of the total enterprises. Calculated at the 350,000 enterprises (excluding industrial and communications enterprises) existing in our country, the percentage is only 0.8 percent. In order to reach the level of 4 percent, we will need to have 14,000 enterprises with research organizations. If we are to reach Japan's level, we will need to have 30,800 enterprises which have research organizations. Currently, we have over 4,000 key enterprises. If they all have research organizations, the percentage is only 1.1 percent.

In enterprise research funding, the scientific research funds of U.S. enterprises make up 75 percent of the national scientific research fund and 95 percent of the national applied research fund. In Japan, enterprises make up 65.2 percent (1977) of the fund and research organizations 18.3 percent. In Soviet Union, enterprise research fund accounts for only 5 percent of its national scientific research fund. As a result, its newspapers and magazines often carry factories' complaints about their serious deficiency in scientific research equipment. In our country, although there are not any statistics done on the subject, by analyzing the proportion of enterprise researchers we can tell that there is not much research funding.

To sum up, the main difference in our country's enterprise research is that its scientific research fund and researchers only account for a relatively small amount of the national scientific research fund and researchers. Deficiencies in funding and manpower are the major characteristics of our weak enterprise research. As a result of the weak technical force in factories and enterprises, most of them can only take care of the technical problems in relation to production and do not have any surplus manpower to work on developmental research. Take Beijing, where the S&T force is relatively strong, for example. The technicians of Beijing's industrial departments make up only about 5.5 percent of its total staff and workers. Most of the medium and small enterprises, however, have much lower percentages. The scientific researchers of Beijing's industrial departments account for only about 0.18 percent of its total staff and workers, which is even lower. This means there are only 18 scientific researchers out of 10,000 staff and workers. Compared to Japan which has 240 scientific researchers in every 10,000 staff and workers, Beijing is 13-fold less. These are the reasons

which cause our development in technology and production to lag behind and which delay the popularization of our scientific research achievements.

III. Factors Responsible for Our Weak Enterprise Research

First, one of the major drawbacks in our scientific research system is the separation of scientific research from production. The organizational form of our scientific research is based on that of Soviet Union in the 1950's. It is a special scientific research organization network in which the organizations are separate from factories and enterprises, both geographically and organizationally. Although the factories and enterprises might be subordinated to the same department as the research organizations, the chain of command within the department is separate: their work is guided, planned and supervised respectively by the production department (section) and the technical department (section). Just because of the separation of scientific research from production, weakness appears in enterprise research. A great proportion of scientific researchers gather in specialized scientific research organizations. This is one of the main characteristics of our scientific research system.

Second, the highly concentrated and planned management system of factories and enterprises hamper the enterprises, limit their enthusiasm in self-development and suppress their aspirations to develop new products and improve the quality of products. The goal of enterprises' planned production becomes that of achieving maximum production. The achievement of a factory is based on how it does with its planned production; the bonuses for the factory and the promotion of managers all depend on this. This sort of output- (or output value) oriented planned system will necessarily suppress the enterprises' aspirations to participate in various stages of technical reform. To begin with, factories will try with all their might to avoid signing contracts with research or designing institutes for producing industrial prototypes and new technologies because the time and effort it takes for doing so conflicts with the basic plan of the factory. Factories will even reject a well-produced new product if it requires new production equipment, thinking that it is a threat to their production. Only the mandatory plan and regulation by responsible superiors can barely guarantee their adoption of new techniques or new technologies. Sometimes the superiors even have to bargain with the factories. Therefore, the highly concentrated management system of enterprises aggravates the separation of scientific research from production. R&D work cannot be squeezed into the schedules of enterprises.

Furthermore, factories and enterprises, research organizations and universities are all closed independent systems. There is not much financial, personnel and academic communication among them. The difference in leadership systems makes such communication very hard among scientific research organizations. In foreign countries, financial, personnel and academic communication and information exchanges promote integration among different organizations. For example: scientific research organizations, factories and enterprises and universities all can, by contract or other ways, carry

on all sorts of communications. Understanding the needs of factories and enterprises, research organizations and universities can make their own research achievements the seed of development by factories. With technical information and practical technical guidance, factories and enterprises can accelerate their speed of developmental research.

Another factor which causes our enterprise research to lag behind is the separation of military research from civil research. In foreign countries, there does not exist any insurmountable barrier between military and civil research. Their national defense departments, through contracts, provide factories and enterprises with scientific research funds. By so doing, the level of these departments is improved, the communication of scientific information increased and the practical utilization of the information developed. New technologies are used by the civilians immediately and social economy is promoted. As shown below, most of the scientific research funds in foreign countries are currently used in military, space and atomic energy: (see Chart 6)

Chart 6. Structure of the Investment of Capitalist Countries in Scientific Research

<u>Nation</u>	<u>Military Technology, Space, Atomic Energy</u>	<u>Other Economic Departments</u>	<u>Health & Education</u>	<u>Aids to Univ.</u>
United States (1967)	86.6	3.2	6.8	3.4
France (1967)	73.6	17.2	1.9	7.3
England (1967)	61.4	24.9	7.1	10.6
FRG (1967)	17.8	62.6	4.7	14.9
Japan (1968)	16.5	75.4	5.7	2.4

Although there is not any figure for Soviet Union's spending in military research, we can be sure that the proportion is also very large. The difference between the United States and Japan, on the one hand, and the Soviet Union, on the other, is that the former, through various kinds of cooperation, better integrate military with civil research and promote economic development. The latter, however, by covering all its military inventions and innovations with an impenetrable carpet creates a burden for its economy. As for our country, we also invest quite a good deal of money in military research, but our communication channels are also blocked. As a result, our industrial research and technological development are affected.

IV. Problems in Relation to the Strengthening of Enterprise Research

With our further reform of the economic management system, the expansion of enterprise autonomy and the function of market mechanism, the needs of enterprises in adopting new technologies and developing new products will become more and more pressing. In such a situation, how do we guide and plan for enterprise research accurately, strengthen developmental research, promote the integration of science with production and carry forward the reform of

the economic management system? To achieve this goal, we should look into the following problems and try to manage them well:

1. Manage Well the Relation Between the Concentration and Dispersal of Enterprise Research Force. As a weak link in our scientific research work, enterprise research needs to be strengthened (including scientific researchers and funds). However, it is evident that we cannot facilitate all the over 350,000 enterprises in our country with research institutes or research labs. We must have some relatively powerful enterprise research institutes, but we also must take care of general enterprises. As a result of free competition and as is required by technical monopoly, enterprise research force is highly concentrated in capitalist countries. Indeed, the research centers of large companies can focus their strength on major technical problems. However, they cannot possibly include the renewal of the hundreds of thousands of products and the reforms of the technologies and techniques of numerous enterprises. Medium and small enterprise research can play the role in places where large enterprise research cannot. For this reason, the United States, Japan and other countries are considering increasing their investment in medium and small enterprise research so as to bring it into full play. For instance, the Ministry of Research and Technology of the FRG has increased its aid to medium and small enterprise research from 5.3 percent in 1972 to 13.4 percent in 1978.

2. Deal with the Organizational Form of Enterprise Research in Accordance with Our National Conditions. First of all, our specialized companies are different from those in foreign countries in their nature. They are not independent accounting units, their production, supply and marketing are in enterprises subordinate to companies. As a result, research institutes, though established at the first level of companies, cannot escape from the influence of the department-ownership system and administrative management which keep it from playing its role properly.

Second, in foreign countries there are two opinions on the organizational form of scientific research in companies and enterprises: one suggests the centralization of scientific research--concentrate the enterprise research force of a company in its S&T center and make its subordinate enterprises' tasks manufacturing samples and carrying out mass production. People with this opinion believe that centralization will simplify the organization of manufacturing and avoid repetition of scientific research among various enterprises. The second opinion objects to the concentration of scientific research force in a unitary scientific research center, thinking that it will be hard to take into account the characteristics of some markets and will cause specialists to break off from their primary task of production.

Currently, our enterprise research force is relatively weak. Most of the first level of our companies are still not counted as accounting units. Also, the overconcentration in industrial management awaits improvement. Under this condition, the adoption of a centralized organizational form will inevitably cause basic-level enterprises to lose their autonomy in R&D. Besides, the research institutes which are in the first level of the companies will certainly become administrative research organizations which do

not have any economic relation with basic-level enterprises. There is not much difference between these institutes and the current ministry-affiliated research institutes, local research institutes, and bureau-affiliated research institutes which overlap each other. Therefore, most of the current medium and small scale companies and enterprises should stress the strengthening of the scientific research force of low-level enterprises, the promotion of the integration of scientific research with production so as to bring their advantages in flexibility into play. Companies should gather together their general scientific research apparatus, equipment and computers to serve enterprises at the lower level, thereby avoiding the repeated purchasing of equipment and establishment of labs and increasing their utilization ratio.

3. Keep the Developmental Scale of Factory Research in Line with the Technical Condition of the Production of Enterprises. As many facts have proved, the development of factory research can promote increases in productivity and improvement in quality. However, the development of scientific research must be based on the current technical conditions of production. It should not deviate from the practical facts and go for undue expansion of scientific research. The development of enterprise research should keep in line with demands and possibility and increase gradually from small to large.

4. Manage Well the Relation Between Factories and Enterprises and Specialized Research Organizations. Factories and enterprises should enthusiastically depend on the scientific research force of specialized research organizations and universities. They can, through contracts or other forms, cooperate with those organizations and receive their guidance by absorbing and purchasing their technical achievements. Research organizations and colleges and universities, on the other hand, should enthusiastically support factories and enterprises, particularly the developmental research of medium and small enterprises. They should adopt some specific measures and policies to coordinate their relationship among themselves so that medium and small enterprises weak in scientific research can take the initiative to depend on existing research organizations. Thus, such a phenomenon as factories and enterprises not having enough strength, while scientific organizations are unable to play their role can be avoided. It is particularly important for us to deal with this relationship well because of the present overconcentration of the scientific research force in scientific research organizations. This is the only way in which we can bring the existing strength into full play. When conditions are ready, an integrated body of scientific research and production can be established according to both parties' will.

12369

CSO: 4008/157

NATIONAL DEVELOPMENTS

COMPUTER TRADE MEETING SETS DEVELOPMENT COURSE

OW211421 Beijing XINHUA Domestic Service in Chinese 0929 GMT 18 Mar 85

[Article by correspondent Ding Shiwu, reporter Gu Honghong]

[Text] Beijing, 18 Mar (XINHUA)--The electronic computer trade conference, which concluded today, has pointed out that future development of the electronic computer industry will follow the general principle of gearing to the application needs.

In the light of this principle, the computer trade should consider it its responsibility and goal to serve the users and hold itself responsible to them. To this end, the computer trade has already readjusted its production structure and product mix.

In terms of production structure, the nation's computer trade has corrected its previous practice of paying more attention to manufacturing principal equipment and hardware than to manufacturing peripheral equipment and software and providing services; it has realized that the data processing service is not only an important part of the computer industry but is also the part that should be developed first. Currently, the computer trade has set up four national companies specialized in software technology, technical services, systems engineering, and computer-controlled facilities engineering to support the computer industry and the application of computers.

In terms of product mix, emphasis will from now on be placed on the manufacturing and application of microcomputers and on the development of urgently needed systems products for terminal application. Last year, China's computer manufacturers produced a total of 23,000 microcomputers such as the Great Wall 0520, Zijin II [Roman two], and ZD-2000. The output was six times higher than that of 1983.

It has been reported that the application of computers in China has now developed from single unit application to systems engineering, and from application in a few areas in some industrial plants or enterprises to the establishment of computerized networks. On this basis, the computer industry will, beginning this year, place emphasis on developing systems products to be used in production process control, business administration, and inventory control in such major state departments as the energy industry, communications, electronics industry, posts and telecommunications, machinery industry, chemical industry, construction, light industry, and textile industry.

NATIONAL DEVELOPMENTS

BRIEFS

ZHEJIANG COMPUTER COMPANY--Hangzhou, 13 Feb (XINHUA)--China's first joint venture for the design and manufacturing of a Chinese language computer--the China Hangxin Electronic Computer Company, Limited--was set up jointly by the Hangzhou Automation Research Institute, the Zhejiang International Trust and Investment Company, and a business concern in Hong Kong, last June in Hangzhou. It now produces "Hangxin II" type, "Hongxin III" and "Hangxin V" type Chinese language computers. The Central Television Station, the Chinese Antarctica scientific research ship, the Sino-Japanese Friendship Hospital, and a number of communications units have used its products with good results. [Summary] [Beijing XINHUA Domestic Service in Chinese 0101 GMT 13 Feb 85 OW]

CSO: 4008/292

APPLIED SCIENCES

ON COUPLING FACTORS OF EXPLOSION

Beijing DIQIU WULI XUEBAO [ACTA GEOPHYSICA SINICA] in Chinese Vol 27, No 6,
Nov 84 pp 537-547

[Article by Zhang Shaoquan [1728 1421 3123] and Guo Jianming [6753 1696 2494]]

[Text] I. Introduction The question of the seismic effect of an explosion plays an important part in the theory and practice of demolition engineering, antiseismic engineering, nuclear explosion engineering, seismic exploration, and seismic depth sounding. A still unresolved issue in this regard is concerned with the calculation of energy conversion process.^[1] In this article, an attempt is made to explore this issue by drawing on the research done in the field of seismic depth sounding.

For an explosion in a solid medium, only a small fraction of the energy is converted into seismic waves. The ratio of the seismic energy E_e and the total explosive energy E_c is defined as the energy conversion coefficient, i.e.,

$$\alpha = E_e/E_c \quad (1)$$

The concept of energy conversion coefficient first appeared in traditional literature on seismology.^[2] But, because of the difficulty of estimating the total energy of a natural earthquake, the attempt to derive a formula for energy conversion coefficient became a very difficult task. Work in this area was greatly motivated by the research of nuclear explosion. In studying the seismic effect of a nuclear explosion, Bath [4] proposed the following formula:

$$M = a + b \log \alpha Q \quad (2)$$

where the parameter α is called the coupling factor; the constants a and b are dependent on the intensity of the earthquake and the conversion relations between explosives and energy. It should be pointed out that the utility of equation (2) is quite limited because it does not provide a formula for α and the values of a and b are generally based on nuclear test data.

To remove this limitation, we propose in this article a semi-empirical formula for calculating the conversion coefficient which is based on statistical analysis of the well explosion data for seismic depth sounding.

II. Determination of the Energy Conversion Coefficient

The near-field effect of an explosion is often described by the formula

$$V = k \cdot Q^m R^{-n} \quad (3)$$

or

$$\log V = \log k + m \log Q - n \log R \quad (4)$$

where k, m, n are parameters to be determined, and V, Q, R are known quantities: V is the speed of ground motion, Q is the amount of explosives, and R is distance. At present, a large quantity of statistical data on the parameters k, m, n have been accumulated from research work in antiseismic engineering, demolition engineering, and seismic depth sounding.

In determining the basic parameters of seismology, the following formula is often used to calculate seismic intensity [2,7]

$$M = \log A/T + \sigma(R) \quad (5)$$

If A/T is substituted by the speed of ground motion V , then equation (5) becomes

$$M = \log V + \sigma(R) \quad (6)$$

By eliminating M between equations (2) and (6), one obtains

$$\log V = a + b \log \alpha Q - \sigma(R) \quad (7)$$

Equations (4) and (7) are the basic equations from which the formulas of conversion coefficients are derived. In order to use the statistical data on k, m, n , it is necessary to assign the same units to Q, R, V in equations (4) and (7). Thus, one obtains

$$\log V = \log k + m \log Q - n \log R + 3(m-n) \quad (8)$$

and

$$\log V = (a-4-3b) + b \log \alpha Q - \sigma(R) \quad (9)$$

In equations (8) and (9), Q is in tons (t), R is in kilometers (km), and V is in centimeters/sec (cm/s).

By eliminating $\log V$ from equations (8) and (9) and rearranging, one obtains

$$[(b-m) \log Q] + [n \log R - \sigma(R)] + [b \log \alpha - \log k - 3(m-n) + (a-4-3b)] = 0. \quad (10)$$

For equation (10) to be true, each term in the bracket must be zero, i.e.,

$$\begin{aligned} (b-m) \log Q &= 0, \quad n \log R - \sigma(R) = 0. \\ b \log \alpha - \log k - 3(m-n) + (a-4-3b) &= 0, \end{aligned} \quad (11)$$

from which we obtain

$$b = m \quad (12)$$

$$\sigma(R) = n \log R \quad (13)$$

$$b \log \alpha = \log k + 3(m-n) - (a - 4 - 3b) \quad (14)$$

By substituting equation (12) into (14) and rearranging, the following general formula for calculating the energy conversion coefficient α is obtained

$$\alpha = (k \cdot 10^{4-a})^{\frac{1}{m}} \cdot 10^{(6 - \frac{3n}{m})} \quad (15)$$

In practice, a simpler formula is often used to study the seismic effect of an explosion [1,3,5]:

$$V = k \left(R/Q^{\frac{1}{3}} \right)^n \quad (16)$$

where $R/Q^{\frac{1}{3}}$ is called the reduced distance. Treating equation (16) as a special case of equation (3), we have

$$V = k \cdot Q^{\frac{n}{3}} \cdot R^{-n} \quad (17)$$

Clearly, the parameter m in equation (3) corresponds to the parameter $n/3$ in equation (17); hence

$$n = 3m \quad (18)$$

By substituting equation (18) into (15), one obtains a special formula for calculating the energy conversion coefficient

$$\alpha = (k \cdot 10^{4-a})^{\frac{3}{n}} \cdot 10^{-3} \quad (19)$$

Both equations (15) and (19) contain the parameter a which must be determined. As mentioned earlier, a is a constant dependent on the relative scale of the seismic intensity; it must be determined from actual measured data. In particular, to determine a , we first rewrite equation (19) in the form

$$a = 4 + \log k - \frac{n}{3} \log(\alpha \cdot 10^3) \quad (20)$$

Now substituting the near-field data $k = 10^3$, $n = 3$, $\alpha = 10^{-2}$ into equation (20) gives $a = 6$. Finally, substituting the value of a back into equations (15) and (19), one obtains a formula for the conversion coefficient which is determined from the statistical parameters of the seismic effect of explosion.

$$\alpha = (k \cdot 10^{-2})^{\frac{1}{m}} \cdot 10^{(6 - \frac{3n}{m})} \quad (21)$$

and

$$\alpha = (k \cdot 10^{-2})^{\frac{3}{n}} \cdot 10^{-3} \quad (22)$$

In applying the above formulas, one must observe the conditions under which they are derived. The statistical parameters (k, m, n) are obtained under the condition where the units of Q (quantity of explosives), R (distance),

V (ground speed) are respectively kg(kilograms), m (meters) and cm/s (centimeters/sec). If the measurement units are different from these, then the formulas for the conversion coefficient will differ accordingly. Table 1 gives other forms of the formula that correspond to equation (22). Clearly, the formula has the simplest form when the following units are used: Q(kt), R(km), V(m/s).

$$\alpha = k \frac{3}{n} \quad (23)$$

Table 1. Commonly Used Formulas for Calculating

measurement unit			Formula for conversions coefficient (α expressed in terms of k, n)
Q	R	V	
kg	m	cm/s	$\alpha = (k \cdot 10^{-3})^{\frac{3}{n}} \cdot 10^{-3}$
t	km	cm/s	$\alpha = (k \cdot 10^{-3})^{\frac{3}{n}} \cdot 10^3$
kt	km	cm/s	$\alpha = (k \cdot 10^{-3})^{\frac{3}{n}}$
kt	km	m/s	$\alpha = k^{\frac{3}{n}}$

In order to verify the formulas (21) and (22) and to further study the factors affecting the energy conversion coefficient, more than 70 sets of statistical data from experiments in antiseismic engineering, demolition engineering, seismic depth sounding, and nuclear explosion have been collected. The α value for each event has been calculated using the formulas given in Table 1. To minimize computation and to provide a visual picture of the distribution of α , we have constructed a set of conversion charts. Fig. 1 shows one of the conversion charts which allows rapid determination of α from given k and n .

Part of the results obtained in this article are also indicated on Fig. 1. Clearly, the majority of points fall between $\alpha = 10^{-3}$ and 10^{-2} , a small portion fall between $\alpha = 10^{-4}$ and 10^{-3} , and only a very few are below 10^{-4} or above 10^{-2} . This α distribution is consistent with those obtained by other methods in the literature [4,5]. This result also establishes the feasibility and credibility of the formula in this article to compute α from k, m , and n .

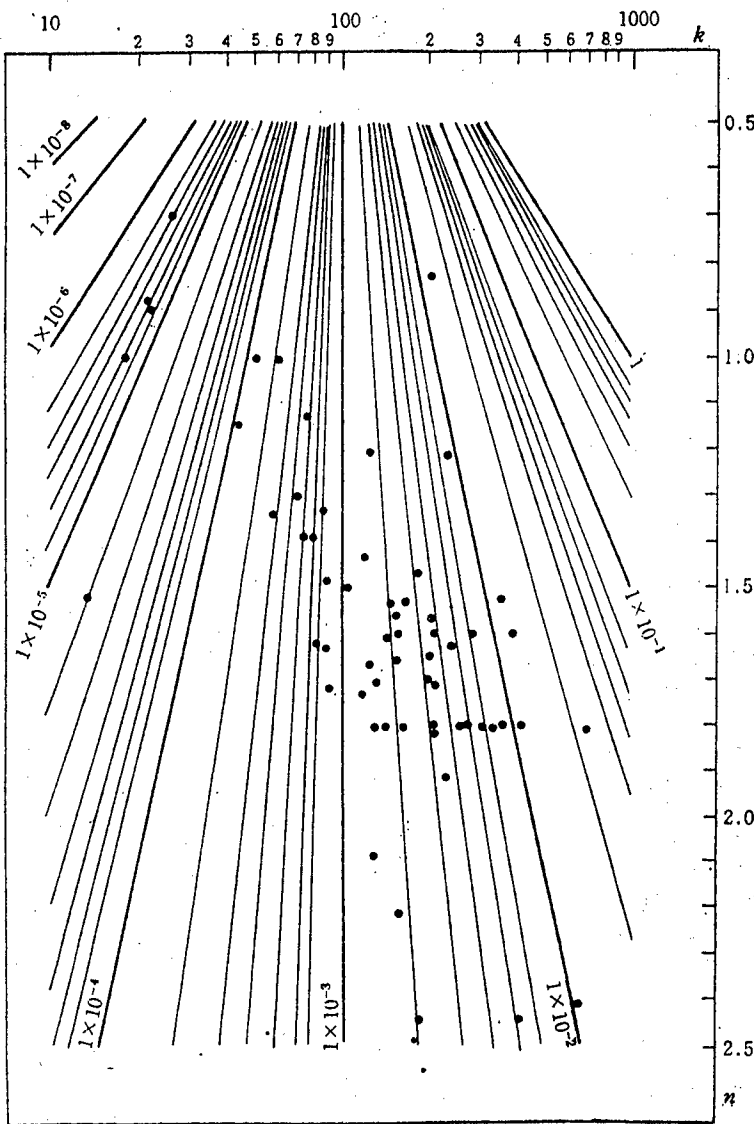

Fig. 1 A Conversion Chart for Rapid Determination of the Energy Conversion Coefficient α (k, n) and the Partial Distribution of α Values Obtained in This Article

Measurement units: Q (kg), R (m), V (cm/sec) $\alpha = (k \cdot 10^{-2})^{\frac{2}{n}} \cdot 10^{-3}$

III. Analysis of the Influence Factors of Conversion Coefficient α

Assume that there are n normalized influence factors f_i ($i=1,2,\dots,n$); also, assume that the i th factor is weighted according to the power m_i ($i=1,2,\dots,n$). Based on actual data of the seismic effect of explosion, it is known that the

effects of influence factors do not accumulate in the form of "weighted sum" but in the form of "weighted product"; i.e.,

$$\alpha = \alpha_0 \prod_{i=1}^n f_i^{m_i} \quad (24)$$

where α_0 denotes the conversion coefficient under ideal conditions, i.e., it is the value of α when $f_i = 1$ ($i=1,2,\dots,n$). To determine the coefficients α_0 and m_i , we first take the logarithm of equation (24):

$$\log \alpha = \log \alpha_0 + \sum_{i=1}^n m_i \log f_i \quad (25)$$

where α , f_i ($i=1,2,\dots,n$) are known. In principle, α_0 and m_i can be determined by using multiple regression [8]. But due to the complexity of the seismic effect of an explosion, particularly the determination of the number of influence factors and the quantification of each factor, the following simplifications are introduced:

1. Number of Influence Factors. According to the analysis by D.D. Bizyukin there can be as many as 60 or more factors which affect the conversion coefficient. But the major factors are rock properties, well depth, filling material, direction of observation number of wells, differential excitation, etc.; these factors are not all independent. For simplicity, only six factors are considered in this article and they are assumed to be independent.

2. Determination of the f_i Values. To derive theoretical formulas for each influence factor would be a very difficult task; on the other hand, to rely totally on experience would produce widely varying results. In this article, the f_i values are determined using empirical tables and a semi-empirical, semi-theoretical approach.

3. Determination of the m_i Values. In this article, the m_i values are not determined statistically from equation (25); rather, they are determined by repeated adjustment of the data from a number of typical blasting tests.

4. Determination of the Value of α_0 . α_0 is the value of the conversion coefficient under ideal conditions. In this article, the average value of α in well blastings is chosen to be $\alpha_0 (=2.03 \times 10^{-3})$. This type of blasting produces the best results in seismic depth sounding work.

For convenience, equation (24) is rewritten as

$$\alpha = \alpha_0 \prod_{i=1}^n F_i \quad (26)$$

where

$$F_i = f_i^{m_i} \quad (27)$$

We shall now present an analysis of the six influence factors:

The Influence of Rock Properties (F_1). The rock properties referred to here include the properties of rocks and soil surrounding the explosives. In general, soil is better than rocks, wet soil is better than dry soil, and loose rocks are better than densely packed rocks. The best results are achieved with underwater blasting.

The influence of rock properties can be illustrated by Fig. 2, which shows a block (or column) of explosives surrounded by a soft layer [6]. The soft layer reflects the moisture content and the degree of looseness of the rock and soil structure. The presence of this layer greatly reduces the energy required to fragmentize the rock medium and therefore greatly increases the energy transmitted to the elastic space. Assume that the inner and outer radii of the soft layer are r_0 , r_1 respectively, the radius of the cavity is r_0 , the shear modulus of the soft layer is λ , the inner wall pressure is P_0 , and the total pressure is F_0 , then the displacement at a distance r from the center is

$$u \sim \frac{r_0 r_1 P_0}{\lambda} \frac{1}{r} = \frac{F_0}{4\pi\lambda} \left(1 + \frac{d}{r_0}\right) \frac{1}{r} \quad (28)$$

where $F_0 = 4\pi r_0^2 \cdot P_0$, $d = r_1 - r_0$. Clearly, for given F_0 , r_0 , and r , the thicker the soft layer (larger d), and the higher the moisture content (small λ), the larger the displacement u .

Figure 2. Schematic Diagram Showing the Influence of Rock Properties

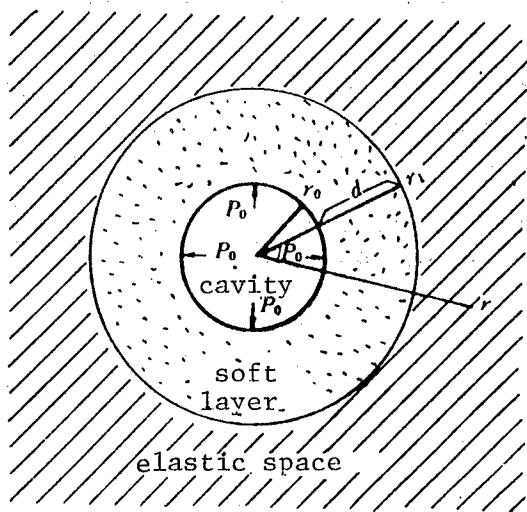

Table 2. gives the influence factors of rock properties f_i and F_i , where m_i is chosen to be 0.9. An underwater explosion can be treated as an explosion in "swamp and mud rocks".

Table 2 Influence of Rock Properties

Table 2-1.

Sequence No	Rock properties	f_i	F_i
1	Densely packed rock	0.28	0.32
2	Loose rock	0.39	0.43
3	marl & sandstone	0.44	0.48
4	Dense pebbles (containing water)	0.50	0.54
5	Sand pebbles (containing water)	0.56	0.59
6	Loess (containing water)	0.67	0.70
7	Clay (containing water)	0.78	0.80
8	Swamp and mud rock	1.00	1.00

The Influence of Well Depth (F_2). The well depth referred to here includes the underground depth of the explosive block or its height above the ground. In a broad sense, the influence of well depth should also include the influence of the terrain (positive or negative) surrounding the well.

Large amount of experimental data have been gathered abroad relating the location of a nuclear blast and the conversion coefficients [4]. We believe that this relation can be illustrated pictorially by the area of the effective contact surface of the explosion as shown in Fig. 3. Let S_0 be the effective contact surface of a solid fullspace explosion, S be the effective contact surface of a solid halfspace explosion at a certain depth (side area of the circular platform). If the depth of the explosives is h and the effective radius of the full-space explosion is r_0 , then

$$\frac{S}{S_0} = \frac{1}{2} \left(1 + \frac{h}{r_0} \right) \quad (29)$$

Fig. 3. Schematic Diagram Showing the Influence of Well Depth

o' - center of blast

r_0 - action radius

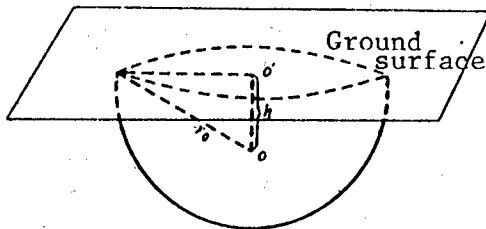

The above equation is valid only when $h \leq r_0$; when $h > r_0$, $\frac{S}{S_0} = 1$. It should be pointed out that the magnitude of r_0 is related to the yield of the explosives Q ; we use the empirical formula

$$r_0 = k Q^{\frac{1}{3}} \quad (30)$$

for estimating r_0 , where k is generally chosen to be 2. The r_0 so obtained is the largest radius (action radius) of the elastic vibration circle. In this formula, Q is in kg, r_0 is in meters. In this article, Q is chosen to be $2t$, which gives $r_0 = 25$ m. By letting

$$f_2 = S/S_0 \quad (31)$$

one can calculate the values of f_2 and F_2 for different values of h . These values are shown in Table 2-2, where $m_2 = 0.8$.

Table 2-2. Influence of Well Depth

No	Well depth(m)	f_2	F_2
1	5 (chamber)	0.6	0.67
2	10	0.7	0.75
3	15	0.8	0.84
4	20	0.9	0.92
5	25	1.0	1.00
6	30	1.0	1.00
7	35	1.0	1.00

In this table, chamber blasting has the smallest influence factor. If the terrain surrounding the well is higher than the well opening (negative terrain), the sequence number of the well depth influence can be raised; conversely, if the terrain surrounding the well is lower than the well opening, the sequence number should be lowered.

The Influence of Filling Material (F_3). The data presented here are strictly empirical. Test results show that the seismic effect can be greatly enhanced by filling with heavy mortar; conversely, if the filling material has low specific gravity or if there is inadequate filling, "popping" or "well ejection" may occur, resulting in spilling of the explosives and reduction in the seismic effect.

The case of chamber blasting can be treated as one with "no filling material". The case of underwater (in lakes or oceans) blasting can be treated as one with

"light mortar filling". If a fault layer is encountered during the drilling process, filling will be more difficult due to water seepage; in this case, the influence value of the filling material should be properly reduced. Table 2-3 shows the influence of filling material, where m_3 is equal to 0.8.

Table 2-3. Influence of Filling

No.	Fill material	f_s	F_s
1	No filling (chamber)	0.25	0.33
2	Slurry	0.50	0.57
3	Light mortar	0.75	0.79
4	Heavy mortar	1.00	1.00

The Influence of the Direction of Observation (F_4). This is a particularly important factor for industrial blasting. In this article, an empirical ratio between the ground motion in the reverse throw direction and the forward throw direction ($a:b = 2.6:1$) [3] is used; also, the magnitude of ground motion is assumed to obey the length formula for the vector radius of an off-set circle:

$$r = \frac{a-b}{2} \cos \theta + \sqrt{\left(\frac{a-b}{2}\right)^2 \cos^2 \theta + ab} \quad (32)$$

where a is the magnitude of the reverse throw direction. Let

$$f_4 = r/a, \quad (33)$$

from which one can calculate the influence values at different directions.

Fig. 4. Schematic Diagram Showing the Influence of the Direction of Observation

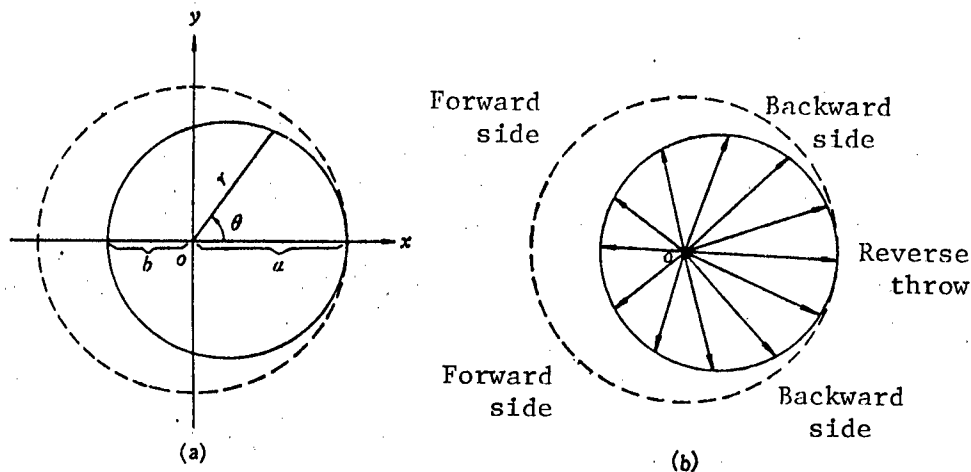

Table 2-4 gives the values of F_4 and f_4 for the forward throw, forward-side, side, backward-side, and reverse throw directions; m_4 is assumed to 0.7.

Table 2-4. Influence of the Direction of Observation

No	Direction of observation	f_4	F_4
1	Forward throw	0.39	0.52
2	Forward	0.46	0.58
3	Side	0.62	0.72
4	Backward	0.87	0.96
5	Reverse throw	1.00	1.00

The Influence of Number of Wells (F_5). For a given yield of the explosives, the effective contact surface between the explosives and the surrounding medium can be increased by using the technique of companion blasting. If the total amount of explosives is divided into n packets (each packet contains an amount q_1 , and has an effective contact area S_1), then from equation (30) one can derive a formula for calculating the total contact surface area S' , assuming that $q_1 = Q/n$, $k_1 = k$:

$$S' = S \cdot n^{\frac{1}{3}} \quad (34)$$

where S is the contact surface area if the explosives are not divided into packets. As n increases, the seismic effect also increases. Actual experience shows that if the total yield of the explosives is $2t$, the effective contact area reaches a stabilization point with approximately 30 well holes; further increase in the number of holes has very little effect. Therefore, we choose

$$f_5 = \left(\frac{n}{30}\right)^{\frac{1}{3}} \quad (35)$$

for estimating the influence of number of wells. Table 2-5 gives the values of f_5 and F_5 , where $m_5 = 0.7$.

It should be emphasized that as the number of wells increases, a sufficiently large distance between the wells must be maintained. Close proximity between the wells may cause coupling (interconnection between the wells), and allow the rocks to be thrown upward, thus reducing the transmission of elastic wave energy. The minimum interwell distance depends on the yield of the explosives; for example, if the yield is 50 kg, the inter-well distance should be 7-8 m. As the yield increase, the distance should increase accordingly.

Table 2-5. The Influence of Number of Wells

Sequence number	Well number	f_s	F_s
1	1 (chamber)	0.32	0.43
2	5	0.55	0.66
3	10	0.68	0.76
4	15	0.81	0.86
5	20	0.87	0.91
6	25	0.94	0.96
7	30 and above	1.00	1.00

The Influence of Differential Excitation (F). In antiseismic engineering, differential blasting techniques are often used to reduce the seismic effect; however, in seismic depth sounding, simultaneous blasting is used to enhance the seismic effect. Therefore, this influence factor cannot be ignored if industrial blasting is used as the source of excitation. Zhang Xueliang et al developed a table for calculating the rate of seismic reduction due to differential blasting [5]. In this article, the formula

$$f_6 = 1 - \int = n^{-0.557} \quad (36)$$

is used to represent the influence of differential excitation. In this formula, $n = Q_t/Q_{max}$, where Q_t is the total yield, Q_{max} is the yield of the largest section of the blast. Clearly, $n=1$ corresponds to the case of simultaneous blasting. In general, $1 < n < 10$. From this we constructed Table 2-6, where $m_6 = 0.7$. It should be noted that the time delay between sections in differential blasting is generally of the order of milliseconds or microseconds. From equation (36) it is known that the time delay itself has little effect; the predominant effect depends on how the explosives are distributed.

Table 2-6. The Influence of Differential Excitation

Sequence number	$n =$	f_s	F_s
1	10	0.28	0.41
2	9	0.29	0.42
3	8	0.31	0.44
4	7	0.33	0.46
5	6	0.37	0.50
6	5	0.41	0.53
7	4	0.46	0.58
8	3	0.55	0.66
9	2	0.68	0.76
10	1.5	0.80	0.90
11	1	1.00	1.00

We have presented a discussion of the six major influence factors using a semi-empirical, semi-theoretical approach. It must be pointed out however that the results are strictly based on statistical analyses; hence the numerical values presented in Tables 2-1 through 2-6 are subject to certain limitations. For example, differences in the geological structures of different regions have not been taken into account; as a result, there may be large variations in the calculated value of α . This is a problem that requires further research.

IV. Application in Seismic Depth Sounding

1. Equivalent Coefficient for Different Forms of Explosion

Among the various forms of excitation used in seismic depth sounding, the seismic effect can be achieved using well companion blasting. In this article, this form of explosion is used as a standard for comparing other forms of explosions, and the concept of equivalent coefficient is introduced.

In equation (1), let the amount of explosives which have been converted into elastic wave energy be q , then

$$\alpha = E / E = q/Q$$

or
$$q = \alpha Q \quad (37)$$

An analogous formula which corresponds to standard explosions is

$$q_0 = \alpha_0 Q_0 \quad (38)$$

Then, to achieve the same seismic effect, we require

$$q_0 = q$$

Substituting equations (37) and (38) into the above equation gives

$$Q_0 = \frac{\alpha}{\alpha_0} Q \quad (39)$$

Let
$$\eta = \alpha / \alpha_0 \quad (40)$$

then
$$Q_0 = \eta Q \quad (41)$$

The quantity Q_0 in the above formula is the equivalent yield of an explosion when referenced to the standard explosion; η is called the equivalent coefficient. Clearly, η represents the number of tons of standard explosives that corresponds to one ton of explosives in a non-standard explosion.

Sun Kezhong et al (1982) calculated the values of η , η for four different forms of explosion.¹⁾ These values are used to calculate α from equation (22), and the corresponding values of η from equation (40). The results are presented in Table 3.

1) Sun Kezhong, Teng Jiwen, Yao Hong, Cheng Lifang, "Attenuation of Seismic Waves and Distribution of Explosion Spectrum in the Exploration of Earth Crust and Upper Screen Structure Using Artificial Explosion", 1982.

Table 3 Conversion Coefficients and Equivalent Coefficients for Four Different Forms of Explosion

sequence number	form of explosion	statistical results		calculated results	
		k	n	α	η
well companion explosion		144.272	1.54	2.03×10^{-3}	1 (standard)
underwater explosion		89.165	1.63	8.10×10^{-4}	0.40
mine explosion		81.678	1.62	6.87×10^{-4}	0.34
chamber explosion		13.158	1.52	1.83×10^{-3}	0.01

It should be pointed out that the "underwater explosion" given in Table 3 refers to explosion in lakes around the Qinghai-Xizang region. For other regions or other forms of underwater explosion such as explosion in the waters of Bohai (approximately 15-20 m underwater), the conversion coefficient and equivalent coefficient may be somewhat higher.2)3)

2. The Seismic Magnitude of Explosion

In the derivation of the conversion coefficient α , the following values are obtained for the coefficients a, b ($a=6$, $b=n/3=1.58/3=0.53$). Substituting these values into equation (2) and changing the unit of Q to tons (t), one obtains:

$$M = 4.42 = 0.53 \log Q \quad (42)$$

Thus, once the yield Q(TNT) and the conversion coefficient α are known, the corresponding magnitude of the explosion can be determined. To illustrate this procedure, three actual examples are presented below:

Example 1 In the case of the Mangyuan well explosion, $Q=2t$; from Table 3 we get $\alpha=2.03 \times 10^{-3}$. Substituting this value into equation (42) gives $M=3.15$. Based on recordings at seismic stations, the magnitude of the corresponding near earthquake is calculated to be approximately 3.1 ± 0.2 .

Example 2 In the case of the Yongdeng chamber explosion, $Q=154t$; from Table 3 we get $\alpha=1.83 \times 10^{-5}$. Substituting this value into equation (42) gives $M=3.07$. Based on recordings at seismic stations, the magnitude of the corresponding near earthquake is calculated to be approximately 3.1 ± 0.3 .

2) National Earthquake Bureau, Geophysical Exploration Brigade, "Summary Report on the Bohai Earthquake Special Task" 1981

3) National Earthquake Bureau, Geophysical Exploration Brigade, "Preliminary Investigation of the Time Variation of P_n Waves in the North China Region During 1981-1982 ----Seismic Recordings of Two Bohai Explosions", 1982

Example 3 In a certain explosion, $Q=20t$. From actual field conditions and the values given in Table 2, we know that $F_1=0.70$ (clay), $F_2=0.84$ (well depth =15m), $F_3=0.57$ (slurry), $F_4=1.0$ (reverse throw direction), $F_5=1.0$ (more than 30 holes), $F_6=1.0$ (simultaneous excitation). By substituting these values into equation (27), one obtains $\alpha = 6.89 \times 10^{-4}$. Substituting this value and the value of Q into equation (42) gives $M=3.43$. Based on seismic recordings, the magnitude of the corresponding near earthquake is calculated to be $M_L=3.3 \pm 0.3$.

The three examples cited above show that although there are considerable variations in the yield and the form of explosion in the three cases, the magnitudes of explosion calculated from the conversion coefficient and the yield are basically in agreement with actual observations.

During the course of this work, comrades Lai Minhui, Wu Minchu, Sun Kezhong of the Chinese Academy of Sciences, Geophysical Institute, comrade Chen Xuebo of the National Earthquake Bureau, Earthquake and Geological Brigade, and comrade Tang Yongan of the Shandong Earthquake Bureau all provided valuable assistance; sincere thanks are extended to all.

References

- [1] Josef Henrych, "The Dynamics of Explosion and Its Use," Amsterdam Elsevier, 1979.
- [2] Richter, F., "Elementary Seismology Freeman," San Francisco, California, 1958.
- [3] Xie Yushou, Wang Yaowen, "Seismic Effect of Industrial Explosion", ACTA GEOPHYSICA SINICA, Vol 11, 154-163, 1962.
- [4] Bath, M., "Introduction to Seismology, Wiley, New York, 1973.
- [5] Zhang Xueliang, Huang Shuze, "Seismic Effect of Explosions", Earthquake Publishers, 1981.
- [6] Zu Zhongxin, "Theoretical Calculations of Explosion-Excited Seismic Waves", ACTA GEOPHYSICA SINICA, Vol 12, 41-50, 1963.
- [7] National Earthquake Bureau (Zhang Shaoquan), "Analysis of Near Earthquakes", Earthquake Publishers, 1977.
- [8] Chinese Academy of Science, Mathematics Research Institute, Statistics Group, "Methods of Regression Analysis", Science Publishers, 1975.

3012

CSO: 4008/194

APPLIED SCIENCES

IMPROVED GONDA'S CIRCUIT DESCRIBED

Beijing DIANZI KEXUE JISHU [ELECTRONIC SCIENCE & TECHNOLOGY] in Chinese No 10, 10 Oct 84 pp 24-25, 16

[Article by Li Changhou [2621 2490 0624], Li Peihong [2621 1014 7703] and Sun Yinqiu [1327 0692 4428], Shanghai Institute of Organic Chemistry, Chinese Academy of Sciences: "Research and Development of a PM-2 Photomultiplier Tube High-Voltage Power Supply"]

[Text] In 1977, Japanese researchers Gonda, et al. presented a new high-voltage power supply circuit for use in photomultiplier tubes (PMT) which attracted quite a bit of public attention. Some persons in China developed a PMT high-voltage power supply based on Gonda's presentation. However, the output voltage of the Gonda circuit can only reach around 1000 V, but most of the PMT mode in China and abroad require a power supply voltage greater than 1000 V, and many require more than 1500 V. We have developed a PM-2 high-voltage power supply which improves the Gonda circuit while preserving its superior features.

The Circuit and Its Operating Principles

The circuitry of the PM-2 high voltage power supply are illustrated in Figure 1. The operating principles are as follows: The high voltage produced through full-wave rectification, but not yet stabilized, is put through three DF-104 control transistors and a current overload protection circuit before it is received by the output terminal. After the output voltage has been divided by a potentiometer, part of it is applied to the positive end of a bias operational amplifier, it is compared to the reference voltage on its negative end and after the voltage difference is amplified by the bias amplifier it controls the reverse automatic gain controller circuit. High frequency output of the oscillator is sent to the reverse automatic gain control circuit through L_1 . Since the reverse automatic gain circuit is controlled by the bias check amplifier, the high frequency output produced at output coil L_2 is in direct proportion to the bias signal. The current induced by L_3 , L_4 , and L_5 in the receiving circuit is detected by three diodes, and after capacitive filtering, is applied between the b-terminal and e-terminal of the DF104 transistor. If the initial voltage has been determined, the output voltage will increase and the bias voltage of the bias check amplifier will decrease. At this time, the voltage between the b and e terminals of the three DF104s will decrease and return to the voltage which was originally set. The reverse is also the case.

3. The direct current power supply of the Colpitts oscillator, reverse automatic gain controller, bias amplifier, and reference voltage source is changed from the four voltage stabilizers in the Gonda circuit to a WB715HB integrated stable voltage supply, which has a voltage regulation rate of 50×10^{-4} and can improve the stability of the entire circuit.
4. The reference voltage of the Gonda circuit (using only a 1N939 voltage regulator) is changed to a highly stable constant current-constant voltage circuit. This improves the stability of the reference voltage and can improve the stability of the entire circuit.
5. The starting point of the Gonda circuit's reference voltage is lowered from the original approximate 0.5 V to 0.13 V so that the circuit's output voltage range changes to -200 to -2000 V (4.6 mA) continuously adjustable.
6. Certain changes are made in some electronic components, an RJJ metallic film precision resistor is used as the sampling voltage divider resistor of the reference voltage source, a multi-coil precision wire-wound potentiometer is used for the sampling voltage divider potentiometer, which further improve the stability of the entire circuit.

Important Indexes and their Methods of Measurement

1. Output voltage range: around -200 to -2000 V continuously adjustable and is directly observed from the voltage indicator on the instrument panel.
2. Output current range: 0-4.6 mA, continuously adjustable. Method of measurement: at no-load time, $I_o=0$; and after receiving a load, load variations are directly observed from the current indicator on the instrument panel.
3. Stability and its method of measurement: In a room with constant temperature and humidity, with an output of 1500 V and 1.5 mA, the potential difference of around 1.499823 V of high-voltage output, is measured using a Chinese-manufactured 0.002 level model UJ32/2 high potential direct current device. The results: When the ac power supply voltage of 220 V varied ± 10 percent, the voltage adjustment rate of the high-voltage output was $\pm 9.4 \times 10^{-6}$; after the machine had been on for half an hour, running continuously for 4 hours, the high-voltage drift was 5.8×10^{-5} , and continuously for 6 hours, the high-voltage drift was 4.1×10^{-5} .
4. Current adjustment rate (or dynamic internal resistance) and its method of measurement:
 - (1) No-load, high-voltage output adjusted to 1500 V, from a sample of about 0.135333 V taken from the voltage divider and measuring it with a domestically manufactured 0.002 level model UJ32/2 high potential dc potential difference meter, the index was 0.135333 V and stable.

(2) Received load R_L (1 M Ω), at this time the output current was 1.5 mA (in actual use, the current consumed by the PMT voltage divider was about 1 mA), but the index of the UJ32/2 potential difference meter dropped to 0.1353327 V, the change in high-voltage output was $\Delta V_o = 0.003325$ V. By definition, the adjustment rate of the current can be derived as: $\Delta V_o/V_o = 2.2 \times 10^{-6}$.

5. Ripple voltage and its method of measurement, based on the experimental formula $V_{o\omega} = S_v(V_o/V_s)V_{s\omega}$ in which $V_{o\omega}$ is the ripple voltage sought; S_v is the voltage adjustment rate of the high-voltage output, value taken as 2×10^{-5} ; V_o is the high voltage output which we often use the value at 1500 V; V_s is the full wave rectified but not yet stable dc high-voltage, value of 2080 V; $V_{s\omega}$ is the ripple voltage at the dc high-voltage positive terminal of voltage which has been through the full-wave rectifier but is not yet stable, using a domestically manufactured model SBM-14 multiple use oscilloscope (peak frequency response 10ns, i.e., 100 MHz) actual measurement of 8 V (peak to peak value). Substituting the above data in the experimental formula, the ripple voltage can be calculated as $V_{o\omega} = 1.15 \times 10^{-4}$ V, i.e., 0.12 mV.

The PM-2 high-voltage power supply measures 350 x 260 x 130 mm, weighs 6.5 kg, and production cost of around 500 yuan.

For a comparison of the PM-2 high-voltage power supply and similar power supplies, see the table below.

The PM-2 high-voltage power supply has already been handed over by the Shanghai Institute of Organic of the Chinese Academy of Sciences to the Nanjing Analytical Instruments Plant for manufacture and in December 1983 it passed scientific research results and new product design appraisal.

Discussion

1. The inventor of the principles of this circuit, Gonda and others, feel that a frequency of about 10 MHz will relay a bias signal, but the results of our experiments show that if the Colpitts oscillator is working normally, a frequency of about 8 MHz can achieve the end of relaying the bias signal. For this reason, it is not necessary to spend excessive time on an oscillation frequency of 10 MHz.

2. In theory, the Gonda circuit can generate a high output voltage and stable voltage power supply, but there are only two ways to do this: one is to increase the regulators, and the other is to improve the voltage tolerance performance of the existing regulator. Our practice shows that if a regulator is added, excessive number of unrelated components can cause interference, and not achieve the goal of stable high-voltage output; if a regulator is not added, but if it is manufactured according to the PM-2 circuit, then the demands on the regulator are very high, and difficult to realize using domestically manufactured components. Therefore, the authors feel that the Gonda circuit cannot further improve the high-voltage output simply.

Country	Firm	Model	Output Voltage	Output Current	Voltage Adjustment Rate	Drift	Load Adjustment Rate	Ripple Voltage	Remarks
Japan		Gonda	0.2-1 kV (continuous)	0-5 mA		better than $\pm 1 \times 10^{-4}$	$\pm 3 \times 10^{-4}$		1977
China	Organics Institute		0.22-1 kV (continuous)	0-5 mA	$\pm 1 \times 10^{-5}$	$\pm 1 \times 10^{-5}$	$\pm 5 \times 10^{-5}$		1979
China	Organics Institute, Wuxi Stable Power Supply Plant	PM-1	0.45-1 kV (continuous)	0-4 mA	$\pm 2.5 \times 10^{-5}$	$\pm 2.5 \times 10^{-5}$	$\pm 2.5 \times 10^{-4}$	0.2 mV	1980
China	Organics Institute	PM-2	0.2-2 kV (continuous)	0-4.6 mA	$\pm 9.5 \times 10^{-6}$	$\pm 2 \times 10^{-5}$	$\pm 1.1 \times 10^{-6}$	0.12 mV	1981

3. The coils in the circuit can be purchased commercially (such as the inductive coil LT104K (assembly) of the domestically manufactured wudeng superheterodyne type receiver), or can also be self-wound. If they are self-wound, the L_1 form can be the same as the 104 K, the primary wire diameter is 0.2 mm, with 5 turns, the secondary wire diameter is 0.35 mm, with 12 turns; the L_2 form can be the same as the 104 K, wire diameter of 0.35 mm, 12 turns; L_3 , L_4 , and L_5 forms can be the same as the 104 A, wire diameter of 0.35 mm, with 14 turns. As long as after detection the signals received on L_3 , L_4 , and L_5 can make the regulator operate normally, there are no special demands on the coils.

4. The PM-2 high-voltage power supply has the advantages of reliability of output stability, simple circuitry, ease of manufacture, and low cost, but it has the disadvantages of placing high demands on high-voltage tubes, and difficulty of overall debugging. Practice proves that in the entire development process, debugging is the most critical link.

8226

CSO: 4008/195

APPLIED SCIENCES

USING A SINGLE-BOARD COMPUTER TO MAINTAIN CONSTANT VOLTAGE, CURRENT SOURCES

Beijing DIANZI KEXUE JISHU [ELECTRONIC SCIENCE & TECHNOLOGY] in Chinese No 10,
10 Oct 84 pp 26-27, 13

[Article by Li Zigang [2621 5261 0474] and Yang Yongzhi [2799 0516 2535],
State-run Plant 4503]

[Text] Constant voltage sources and constant current sources, especially high voltage power supplies going from several tens of thousands of volts to several hundreds of thousands of volts, in some special equipment or special situations, when increasing power, require rising slowly from zero to a predetermined voltage or current and then stabilizing at that point. When load changes or input voltage waves cause deviations in the predetermined value of the output voltage, it should be able to restore the predetermined value rapidly. When the task is over, it must slowly decline to zero. These processes are adjusted by manually turning a potentiometer which wastes time and is not very precise. To resolve these problems, we have tested the use of a single-board computer to control constant voltage and constant current courses, and have proved that it is feasible. The connecting circuit is illustrated in Figure 1. The part inside the broken line is the open-loop control. The closed-loop control can play a clear role on rapid regulation, maintenance precision, and stability of the power supply.

Checking the power supply output by means of the A/D converter, the CMC-80 microcomputer has an ADC0809 chip, so it was not necessary to add hardware. The power supply output voltage value is received directly by the A/D converter through the voltage divider, is converted into digital form and sent to the computer. It is compared with the input data of the DAC, and the computer sends the digital quantity of the ADC input through the other PIO to an LED display (which can also display comparative error). Appropriate software can carry out rapid control, including advanced and corrected, of different load tasks and thus can make the power supply output conform to work demands.

Software Design

In order to outline the program modules written for the power supply for automatic power turn-on, data acquisition, processing and adjustment which include sending data to increase power, reducing data to reduce power, A/D conversion, numerical value filtering, PID adjustment, and display modules, they are shown in a flow chart in Figure 2.

In order to ensure that the output voltage or current would rise evenly, taking into account the fact that the power supply transition process time is long, there should be a delay after each data transmission. Thus when designing the software, this point was taken into consideration in the data transmission to increase power and reduce data to reduce power subprograms, and a delay subprogram was written for iterative calling. The power supply transitional process time can be derived from computation or from measurement, and if it increases by steps of 1 in order then correspondingly it can diminish the delay time or number of steps.

In order to prevent interference, corresponding measures were also taken in software, i.e., when individual or several sample values exceed the limit due to interference, the digital filter filters them out. When the continuous occurrence of sample values which exceed the limit is greater than a pre-determined value or predetermined time, it shifts to the warning processor. When the sample value is at the upper or lower limit or exceeds the precision zone of the power supply output, the previous two or four sample values can be saved and added to the current sample value to find the average as a sample value to make the sample value more in line with actuality and carry out PID regulation.

The display program module can display the sample value, calculate the average sample value, and can also display errors. What we used was the display sample value.

Several Points of Explanation

1. Using a single-board computer to control a power supply is far from exploiting the full potential of the single-board computer. If several D/A converters are connected to a decoder for chip selection, several power supplies can be controlled on a time-share basis. An A/D converter connected

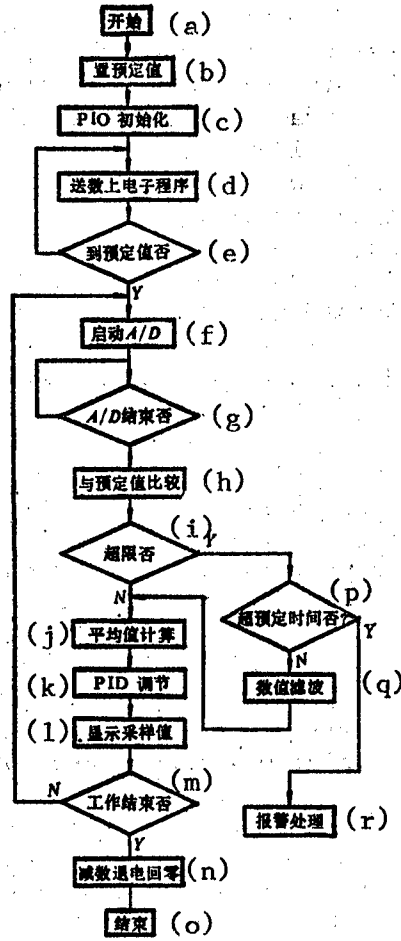

Figure 2.

Key:

- | | |
|---------------------------------------|--|
| a. Start | i. Does it exceed limit? |
| b. Set preset value | j. Compute average value |
| c. Initialize PIO | k. PID regulation |
| d. Send data to power turn-on program | l. Display sample value |
| e. Has preset value been reached? | m. Is task completed? |
| f. Start A/D | n. Reduce data to return power to zero |
| g. A/D concluded? | o. End |
| h. Compare with preset value | p. Has preset time been exceeded? |
| | q. Digital value filter |
| | r. Warning processing |

with several different multichannel switches to form an 8, 16, 32 or even 64 channel analog input channel to carry out closed-loop control of many power supplies, would fully exploit the capability of the single-board computer. This series is only an experimental device for controlling one power supply. Its circuitry is illustrated in Figure 3.

2. For reference control of highly precise and highly stable power supply, it requires only switching D/A and A/D converters for corresponding number of places. We used a 12 place D/A converter open loop control constant voltage power supply, a digital voltage meter for inspection, and measured power supply precision at <0.05 percent.

3. A system controlling several power supplies can use a CTC (CMC-80 single-board computer with a CTC) fixed time interrupt, cyclical rotational monitoring of each power supplied for closed loop control. Adopting a parallel work method can permit the CPU more time for computation, processing and information transfer with peripheral devices. This system is equipped with a printer (CMC-80 microcomputer equipped microprinter) which can print out such parameters as output voltage or current, and load work state collected at set times.

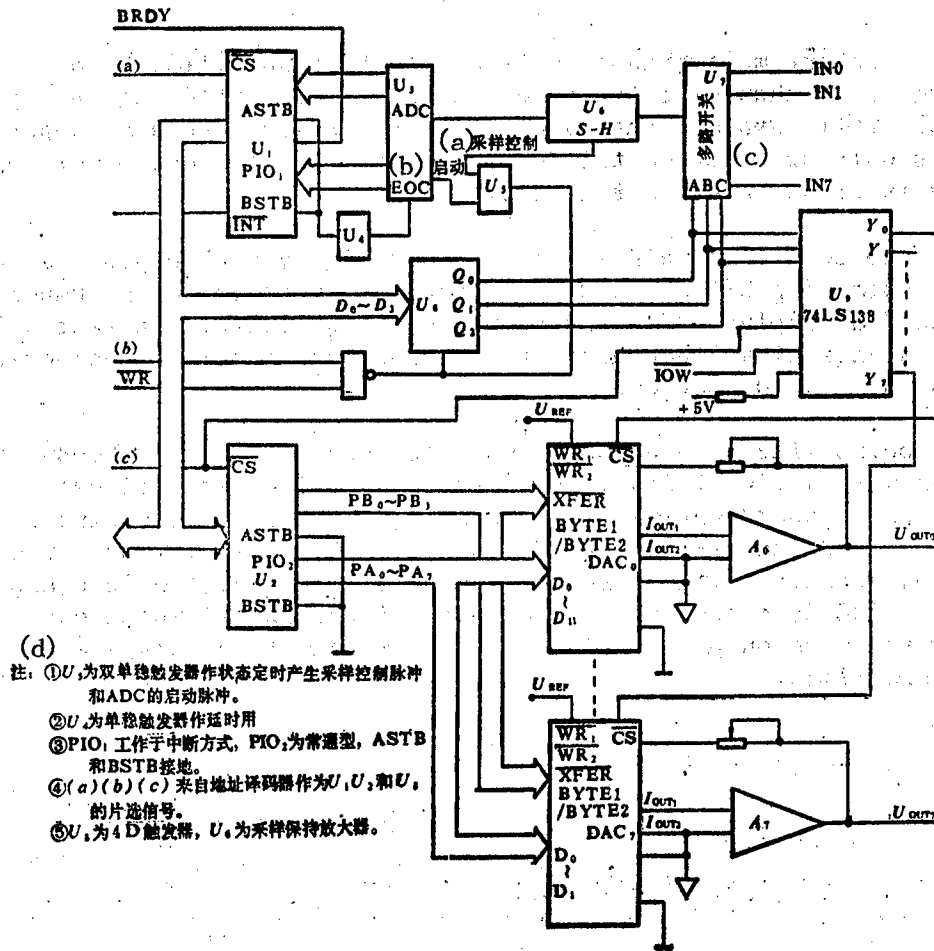

Figure 3

Key:

- a. Sample control
- b. Start
- c. Multiple switches
- d. Notes:

1. U_5 is dual monostable triggers for producing state fixed time production sampling control pulse and ADC start pulse
2. U_4 is monostable trigger for time delay
3. PIO_1 operates in interrupt mode, PIO_2 is common type, $ASTB$ and $BSTB$ are ground connections
4. (a), (b), (c) are from address decoder as chip select signals of U_1, U_2 , and U_4
5. U_8 is 4D trigger, U_6 is sample maintenance amplifier

8226

CSO: 4008/195

APPLIED SCIENCES

PRC OFFICIALLY NAMES ANTARCTIC LAKE 'XIHU'

OW011025 Beijing XINHUA Domestic Service in Chinese 1217 GMT 27 Feb 85

[By reporters Zhu Youdi and Giu Weimin]

[Text] King George Island, 26 February (XINHUA)--A crystal-clear, sparkling lake north of China's Changcheng Station in antarctica was recently officially names "Xihu," with a brass nameplate bearing its name in Chinese and English erected at its side. This is the first lake in Antarctica named by China.

The lake is located 200 meters from the Changchung Station and situation in a small valley surrounded by snowy mountains to its northeast are small hills; and to its south is a series of steep mountain slopes composed of pyrogenic rocks. The valley opens up directly to the rippling Changcheng Gulf. The Antarctic "Xihu" is 6,000 square meters wide, and its water is 10 meters deep. At present, on the banks of the lake are remnant snow, ice ridges, snow-covered hills, and protruding rocks, with their images reflected upside down in the crystal-clear, sparkling water. The lake has abundant and relatively fine-quality water. Even in the late winter season, the water 4 to 5 meters beneath the surface does not freeze, thus ensuring an adequate supply of water for daily life and work at the Changcheng Station.

Up on a small hill east of the Antarctic "Xihu" is a 4-meter-high signpost made from a stainless steel gravity sampling pipe [zhong li qu yqng guan 6850 0500 0648 2876 4619], erected by members of the expedition group from Zhenjiang. On the upper side of the signpost is a nameplate made from a stainless steel rudder, bearing the characters "Hangzhou, China," with the sharp edge of the rudder pointing upward toward the sky, indicating the courageous and pioneering spirit of the expedition group members.

CSO: 4008/275

APPLIED SCIENCES

BRIEFS

FUJIAN COMPUTER TECHNOLOGY--Fuzhou, 24 Jan (XINHUA)--The Fujian Provincial Electronic Computer Research Institute has designed and produced the Bailing Chinese language card and two coding methods. They passed technical tests in Fuzhou on 23 February. The Bailing Chinese language card can be inserted into IBM PC/XT computer to show direct Chinese language information. [Summary] [Beijing XINHUA Domestic Service in Chinese 1350 GMT 24 Jan 85 OW]

SHANDONG COMPUTER TECHNOLOGY--Jinan, 27 Jan (XINHUA)--A new Chinese language pinyin system for computer operation--QPC-DOS--has passed technical tests in Shandong's Yantai City recently. The system can input some 7,000 Chinese characters and common punctuation marks into a computer, and may input additional information if necessary. [Summary] [Beijing XINHUA Domestic Service in Chinese 0850 GMT 27 Jan 85 OW]

ZHEJIANG WASTEPAPER--Hangzhou, 7 Feb (XINHUA)--The Hangzhou Chemical Industry Research Institute recently successfully produced an HD-6 type color eraser for wastepaper. Wastepaper can be reused in producing newsprint, writing paper and napkins after processing with the HD-6 type eraser. [Summary] [Beijing XINHUA Domestic Service in Chinese 0020 GMT 7 Feb 85 OW]

CHINESE CHARACTER COMPUTERS--Beijing 7 Feb (XINHUA)--A demonstration of the new method of entering Chinese characters into computers was held in Beijing's Xinqiao Restaurant on 7 February. The method, which makes use of 26 keys and 5-stroke basic Chinese character forms, was developed and further improved by Wang Yongmin, director of the Board of Directors of the Honan Society for the Study of Information in Chinese Characters. An operator who has studied this method for 4 months, is able to type 136 Chinese characters per minute. [Summary] [Beijing XINHUA Domestic Service in Chinese 1434 GMT 7 Feb 85 OW]

CHINESE-CHARACTER SOFTWARE PRODUCED--Beijing, 15 Feb (XINHUA)--Another advanced Chinese-character computer system--the Xinshidai [New Times] Chinese-character computer system--was recently produced in Beijing. [passage omitted] The Xinshidai Chinese-Character computer system runs on IBM-PC computers which are popular in China. The system contains an IC [integrated circuit] plate as part of the computer hardware and some software to store the necessary programs. [passage omitted] There are three Chinese-character input methods--the Pinyin, the eight-stroke ideograms, and the four-corner codes. The three methods can be used interchangeably. [passage omitted] The Xinshidai Chinese-character

computer system was developed by the Beijing Documents Service Center and the state-operated Changcheng Scientific Instruments Plant. At present, it has been put into batch production. [Excerpts] [By Zhuo Peirong] [Beijing XINHUA Domestic Service in Chinese 1235 GMT 15 Feb 85 OW]

JILIN UTILIZATION OF MICROCOMPUTERS--In 1984, Jilin Province had made great progress in utilization of microcomputers and especially in using them for enterprise transformation. At present, about 800 microcomputers have been used by industrial and communications, agricultural, financial and trade, capital construction, scientific research, cultural and educational, and public health departments. [Summary] [Changchun Jilin Provincial Service in Mandarin 1030 GMT 21 Mar 85 SK]

CSO: 4008/291

ENVIRONMENTAL QUALITY

CONFERENCE ON ENVIRONMENTAL PROTECTION IN BEIJING CONVENED

Beijing HUANJING BAOHU [ENVIRONMENTAL PROTECTION] in Chinese No 5, 1984 p 29

[Article by Wang Shuqi [3769 2885 6386]: "Beijing Municipal Government Convenes Conference on Environmental Protection Work"]

[Text] In order to implement fully the official written reply from the CPC Central Committee and the State Council on "The Overall Planning Program for the Building of Beijing Municipality," and the spirit of the Second National Conference on Environmental Protection, the Beijing Municipal Government convened a conference on environmental protection work. A total of more than 300 people from relevant departments of the municipal government, relevant units of the Central Committee, and comrades in charge of PLA units in Beijing and in institutions of higher learning attended this conference.

Deputy Mayor, Han Boping [7281 0130 1627] presided at the conference, and deputy mayor Zhang Baifa [1728 4102 4099] gave a report titled, "Carry out the 'official reply' from the Central Committee and Strive to Usher In a New Situation in Environmental Protection Work in the Capital. Minister Li Ximing [2621 6932 6900] of the Ministry of Urban and Rural Construction and Environmental Protection, and Mayor Chen Xitong [7115 1585 0681] made important speeches.

In his report, Deputy Mayor Zhang Baifa noted that during the past 10 years, as a result of the joint efforts of all levels of the municipal government, the Central Committee, and units stationed in Beijing, environmental protection work has scored definite accomplishments. However, environmental pollution remains very serious. He said that this year marks the twenty-fifth anniversary of the founding of the nation, and that all trades and professions should rally their spirits and go all out in taking real action to celebrate the national anniversary. In the field of environmental protection, 12 tasks have to be completed as follows: Complete the conversion of the 209 boilers in the urban area that have not yet been converted. It is also necessary to convert a number of tea boilers, kilns, and movable boilers. 2. Bring into being three black smoke-free zones, namely The Erlong Road street office in the western part of the city, part of the area to the west of Xierhuan, and the Xiang Shan scenic region. 3. Supply heat over a continuous area for a reduction or less building of smokestacks. 4. Increase in raw materials for cleaning, completion of the building of

the project for bringing coal gas into the city from the coke ovens at the Capital Steel mill, and strenuous efforts to complete by year's end the pipeline to bring natural gas into Beijing from the north China oilfield. Additionally, more honeycomb coal discs should be produced to take the place of coal briquets, and research and development should be carried out to promote new style stoves for homes, and energy saving stove tiles to reduce the amount of pollution from small coal stoves. 5. Designation of protected headwaters zones and formulation of management methods to assure protection of Miyun, Guanting, and Huairou reservoirs and the purity of water in channels carrying water. 6. Substantial cleaning up of river water in the upper sections of the Wanquan River, the Chang River, the Beihucheng River, and the Liangma River, removal of silt from river beds, planting of greenery on both banks of rivers, and building of forest belts along rivers to make them into rest areas for people. 7. Dredge Shisha Hai, complete first phase projects, and begin to dredge Honglingjin Lake in Chaoyang District. 8. Take firmly in hand the control of effluent from chemical industries, pharmaceutical, textile, paper making and metallurgy plants, and from hospitals. The industrial effluent treatment rate is to be increased from 38 to 43 percent. 9. Solution within a definite period of time of pollution from a number of enterprises that disturbs the citizenry. Renovation, merger, or movement of 52 industrial plants and workshops in the area inside Sanhuan Road. On-site control of 200 sources of pollution. 10. Closing of an additional 100 electroplating plants and sites. 11. Strict control of noise that disturbs the people. All motor vehicles are to use low noise horns, production of the number of small Model 121 trucks is to be increased, and the old heavily polluting Dongfeng motor vehicles are to be improved. All three-wheel motor vehicles that have not been improved are to be prohibited entry to Sanhuan Road as of the end of the year. 12. Halt to the use of the pesticides benzene hexachloride and DDT.

In his speech, Minister Li Ximing of the Ministry of Urban and Rural Construction and Environmental Protection noted that the situation in environmental protection work throughout the country is currently very good. The nation has made environmental protection a basic national policy. Leaders at all levels are devoting increasingly serious attention to it, and the broad masses of people are also extraordinarily concerned about it. People throughout the country look to Beijing and hope that Beijing will diligently study and implement the Central Committee's "official reply and the spirit of the Second National Conference on Environmental Protection, and serve as a model for the ushering in of a new situation in environmental protection from which experience can be drawn.

Mayor Chen Xitong pointed out that the Central Committee has placed very high requirements on Beijing Municipality, and that our work still falls far short of these requirements. The Central Committee's and the State Council's official reply to "The Overall Plan Program for the Building of Beijing Municipality" is a programmatic document for the ushering in of a new situation in the building of the capital city. Everyone should study it to increase their understanding and to bring their thinking in line with the "official reply" from the Central Committee. He said that the municipal

government has several times discussed the 12 environmental protection tasks to be completed this year, and that individual departments and individual units will have to implement them one by one. One must keep one's word, and action must bring results. When something is said, it should be resolutely completed. He also pointed out that the law must be strictly maintained and violators must be prosecuted; otherwise, the damage done will be great and it will become impossible to do many things.

Delegates to the conference unified their understanding and increased their confidence as a result of this conference. They unanimously said that they would shoulder their own responsibilities and take them back for conscientious implementation and achieve results to make a contribution in building Beijing into a clean, surpassingly beautiful, and ecologically healthy civilized city.

9432

CSO: 4008/360

ENVIRONMENTAL QUALITY

RESEARCH ON AGRICULTURAL ENVIRONMENTAL PROTECTION DISCUSSED

Tianjin NONGYE HUANJING [ENVIRONMENTAL PROTECTION] in Chinese No 8,
Aug 84 pp 13-15

[Article by Jiang Tianzhong [5592 1131 0022]: "Several Things We Have Learned in Launching Scientific Research Work in Agricultural Environmental Protection"]

[Text] In 1974, the former Ministry of Agriculture convened in Beijing a conference on cooperation in the scientific research in agricultural environmental protection. Several dozens schools and institutions of the agricultural, aquatic products, public health and urban construction departments, the academy of sciences and the education department were organized to launch cooperation in scientific research involving "the criteria for the water quality in farmland irrigation," "the criteria for the water quality in fishery," and "the criteria for the safe use of farm chemicals." This conference was the first nationwide conference on environmental protection which the agricultural department convened since the First National Conference on Environmental Protection. Since that time, the agricultural department has begun to launch scientific research in environmental protection in an organized and planned manner and on a broader scale. In the last 10 years, our country's scientific research in agricultural environmental protection has developed rapidly with relatively great success. Reviewing the path which we have traversed and summing up our experiences and lessons will no doubt be extremely beneficial to the development of our scientific research in agricultural environmental protection in the future.

In the early days of launching the scientific research work on environmental protection, the agricultural department had encountered great difficulties: First, it lacked the means of analysis. Most of the schools and scientific research institutes did not have such analyzers as the gas chromatographer and atomic absorption spectrophotometer. Some units did not even have a simple thin layer analyzer. Second, it had a very weak technological strength. At the time, many scientific research personnel had not mastered the technique of analyzing pollutants. In light of this situation, under the vigorous support of the entomological research institute of the Chinese Academy of Sciences, we held training classes on the technique of analysis, and trained personnel in thin layer analysis and gas chromatography analysis for the various units. After the training classes, the various cooperating units gave prominence to the spirit of building an enterprise through arduous effort, helped one another, helped supply one another's needs, and won victory over one hardship after another, and accomplished the above-mentioned three research projects on schedule. After that, the scientific research cooperative group in agricultural environmental protection continued to expand, and successively launched research

in more than a dozen major projects, including the evaluation on the environmental quality of 37 key sewage irrigation zones, the criteria for controlling harmful substance in the mud for farm use, the investigation of the background value of the toxic substance in the major agricultural soil and grain crops of 13 provinces and municipalities, the investigation of the condition of pollution by farm chemicals in the key grain, vegetable, fruit, tobacco and tea producing regions, the impact of farm chemicals on the ecology, the criteria for the safe use of new farm chemicals, the criteria for sanitation in chicken feed, the unified method of analyzing the residues of farm chemicals, the approach to control nitrates and nitrites in vegetables, and the rational utilization of dross and urban garbage. Presently, we have scored achievements in over 100 projects, among which some have already obtained awards of achievement from the Ministry of Agriculture and the localities. Some results are being summarized and appraised. The environmental office of the Ministry of Agriculture, Animal Husbandry and Fishery is presently compiling the results of scientific research in agricultural environmental protection. This effort is a very good review and summary of scientific research in environmental protection of the agricultural department in the last 10 years. All this has shown that, after 10 years of hard work, we have already laid a good foundation for scientific research in agricultural environmental protection, and has created favorable factors for future development.

In reviewing scientific research work in agricultural environmental protection in the last 10 years, we have come up with the following major realizations:

I. We Should Persevere in Orienting Scientific Research on Agricultural Environmental Protection Toward the Reality of Production and Toward Serving Economic Construction.

Agricultural environmental protection involves a broad area and numerous scientific research projects. But of first importance is the study of those projects which will yield great economic and environmental results and which will play an obvious role in agricultural production. This means that we must orient scientific research on agricultural environmental protection toward the reality of production and toward solving practical problems. This is an important guiding ideology in our work of launching scientific research in agricultural environmental protection. Practice has proved that, only by adhering to this guiding ideology can scientific research in agricultural environmental protection display great vitality. For this purpose, we must vigorously encourage scientific research personnel to penetrate into the reality of production to carry out investigation and study in a widespread manner, firmly erect the viewpoint of letting scientific research serve production, and prevent and overcome the tendency of scientific research for its own sake. Furthermore, we must strictly guard well the pass of scientific research planning, conscientiously examine and verify our topics of research, and carry out analysis and pre-appraisal on the economic and environmental results of each topic.

II. We Should Organize and Launch Cooperation in Scientific Research and Concentrate Our Strength on Making Breakthroughs.

Practice has proved that an important measure in launching well scientific research in agricultural environmental protection is to organize comprehensive battles to make breakthroughs through interdepartmental and multi-disciplinary cooperation. There are many agricultural species, and great differences in the natural factors of different localities. Moreover, pollutants are complex. Consequently, the research task of many projects is extremely cumbersome. Highly incompatible with the above is the limited strength of the various scientific research units. Thus, to launch scientific research and score results as soon as possible, we must unify and organize the strength of various aspects to launch cooperation in scientific research and concentrate strength on making breakthroughs. In the last 10 years, we were able to accomplish more than a dozen major research projects under a situation when we had relatively weak strength. One important reason was because we had organized and launched cooperation in scientific research.

III. We Must Strengthen the Management in Scientific Research.

The management in scientific research is highly related to the progress and success in scientific research. With the continuous development of the scientific research in agricultural environmental protection, the scope of scientific research has also gradually expanded, and more and more units have participated in research. This way, it becomes more important to strengthen the management in scientific research. In light of the problems existing in this respect, we are setting up and perfecting our systems related to such aspects as topic verification, plan examination and verification, implementation of scientific research plans, result appraisal and report, and accounting involving funds. On the basis of bringing its leading role into full play, the cooperative group should strengthen its relationship with the other cooperating units, understand the situation of the progress in scientific research, help solve problems in scientific research, and supervise these units in working hard to accomplish the scheduled tasks. We should strengthen the relationship among concerned departments and units and avoid overlapping scientific research tasks.

IV. We Should Pay Attention to The Building of a Scientific and Technological Rank.

Scientific research is supported by scientific and technological personnel. The reason why we were able to score obvious successes in scientific research in agricultural environmental protection is because we have initially built a scientific and technological rank in agricultural environmental protection. The number of scientific and technological personnel taking part in scientific research in agricultural environmental protection has increased from several dozens in the past to roughly 1,000 now. Among them, nearly 100 people are assistant researchers or at a level above that of assistant researcher. They form a core force in the scientific research in agricultural environmental protection. In order to accelerate the training of skilled personnel, the Zhejiang Agricultural University has specially set up a department in environmental protection.

V. We Must Set Up A Number of Specialized Research Organs.

Practice has proved that, in order to adapt to the development of the scientific research cause in agricultural environmental protection, we must correspondingly set up a number of scientific research organs which specialize in the research in agricultural environmental protection. Over the last several years, the Ministry of Agriculture, Animal Husbandry and Fishery has set up, under the jurisdiction of the ministry, a scientific research institute in environmental protection and a central monitoring station. Many specialized institutes of the Chinese Academy of Agricultural Sciences have also set up research offices (groups) in agricultural environmental protection. The agricultural bureaus and academies agricultural sciences of many provinces, municipalities and autonomous regions have successively set up monitoring stations in agricultural environmental protection and research institutes (offices) in agricultural environmental protection.

In the last 10 years, we have scored definite successes in scientific research in agricultural environmental protection. However, generally speaking, we have still failed to meet the needs of the cause of agricultural environmental protection and the development of agricultural production, and have failed to put forth economic and easily popularized measures of prevention and control. We have not even clarified the situation of pollution and the condition of ecological destruction in many places. For one reason or another, we have still failed to launch research on certain urgently-needed technologies in agricultural environmental protection. In terms of scientific research in agricultural environmental protection itself, such problems as insufficient funding, narrow professional scope among the scientific research ranks, the lack of long-term programs and plans, relative weakness in scientific research strength, and the lack of pioneers in certain disciplines exist. All these will await solution one by one in the future.

9335

CSO: 4008/201

18 April 1985

ENVIRONMENTAL QUALITY

MAINTENANCE OF BALANCED ECOSYSTEM FOR AGRICULTURAL GROWTH URGED

Beijing HUANJING BAOHU [ENVIRONMENTAL PROTECTION] in Chinese No 5, 1984 pp 5-7.

[Article by Wei Shuangfeng [7614 7175 7685], Assistant Professor, Agricultural Economics Department, South China Institute of Agriculture and Yao Shujie [1202 2885 3381], Agricultural Economics Department, South China Tropical Crops Institute: "Brief Discussion of the Problem of Unifying Ecological, Environmental and Economic Benefits"]

[Text] 1. The Unity of Ecological, Environmental, and Economic Benefits Is a Strategic Task in the Modernization of Agriculture.

China's people are facing a mighty and daunting task, namely the building of their motherland into a powerful modernized socialist country. Agriculture is the foundation of the national economy, and is closely related to the four modernizations. The modernization of agriculture not only requires that all sectors of the national economy provide ample amounts of superior quality foods and industrial raw materials, but also that it create a balanced ecosystem that is highly effective and of surpassing quality for the entire biosphere.

Everyone realizes that an ecosystem is very complex and that it includes producers, consumers, decomposers, and non-living matter. The main producer is green plants, and consumers include mankind, herbivorous animals, and carnivorous animals. Decomposers are all sorts of micro-organisms. The entire ecosystem not only is acted upon and restricted by the external environment, but all parts of the system are also mutually influenced and restricted by food. In a normally functioning ecosystem, the flow of energy and the cycling of matter goes on continuously; however, at any specific period of time, consumers and decomposers maintain a relatively balanced state. This balanced state is termed ecological balance. Mankind's activities can promote the ecological balance or they can destroy it; thus, it is necessary to pay special attention to this problem in building an economy. China's agricultural population accounts for more than 80 percent of the country's population. In so large an agricultural country where agricultural production is so special in nature, damage to the ecological environment means severe and protracted damage to agriculture. Furthermore agriculture's effect on the environment is also far-reaching and long-lasting.

Only protection and improvement of the ecological environment can bring about the development of production, the creation of wealth for the people, the creation of wealth for descendants, and increase in benefits from the agricultural economy.

2. Ecological Benefits, Environmental Benefits, and Economic Benefits Are Dialectically Unified.

The relationship between living creatures and the environment existed long before the advent of mankind. Study of the ecology aims at improvement of the environment, promotion of ecological balance, and the building of a highly effective, high quality ecosystem in order to advance development of the national economy. Thus, the problem of effectiveness discussed here is related directly to human activities (production and living). Were it not for human activities, the question of effectiveness would not exist.

The effect on the ecosystem of man's activities are both beneficial and detrimental. People's evaluation and comparison of these advantages and disadvantages effects are termed ecological effectiveness. Generally speaking, when man's activities are beneficial to the ecological balance, ecological benefits are good; otherwise they are poor. Man's activities may be divided into three types in terms of their effect on the ecosystem. The first kind are activities beneficial to the ecosystem such as the growing of grass, the planting of trees, and afforestation which serve to break winds, stabilize sands, and conserve soil and water. The second kind are activities destructive to the ecological balance such as reckless cutting and denudation of forests and ill-advised reclamation of lakelands to create fields, both of which can lead to soil erosion and inundation by floodwaters. For example, after Krushchev came to power in the USSR, destruction of forests and clearing of virgin lands was carried out in Siberia and Kazakstan. As a result of the serious damage done to plant cover, plus a chaotic farming system, a single black windstorm in 1960 caused damage to 4 million hectares of land. Another windstorm in 1963 damaged 20 million hectares. Historically, we have also learned some serious lessons. Destruction of vast tracts of primeval forests and reclamation from the sea and lakes of vast tracts have caused inestimable damage. The third kind of activities are those that have both beneficial and damaging effects on the ecosystem as, for example, the building of reservoirs, which can prevent flood and drought disasters, but which can also cut off routes to spawning grounds for some fish species leading to their extinction. Somewhat more serious has been the situation resulting from the USSR's building of the Aswan Dam for Egypt, which cut off supplies of humus to the lower reaches of the Nile River resulting in a series of serious consequences such as gradual impoverishment of the soil in the lower reaches and the spread of blood flukes in the Nile River delta.

The environment is a condition for the existence and development of the ecology, and mankind's activities have both a beneficial and detrimental effect on the environment. Comparison and evaluation of these beneficial and detrimental influences is termed environmental benefits. Similarly,

man's activities may be divided into three categories in terms of environmental effects. The first kind is activities beneficial to the environment such as use of and purification of the "three wastes" [waste water, waste gas, and industrial residues], and the planting of trees and the growing of grass to beautify and purify the environment. The second kind is activities detrimental to the environment as, for example, excessive discharge of the "three wastes," by industry, or excessive use of chemical fertilizers and pesticides, which can cause serious environmental pollution. The third kind is activities that are both beneficial and detrimental. Examples include concentration of population and the building of cities, which create a very convenient environment of human life, but which cause large amounts of pollution and noise arising from over-concentration of population, excessive urban expansion, and vehicles used for transportation. Discharge of the "three wastes" resulting from industrial production and the daily life of inhabitants are bound to pose a serious threat to man's health. The fact that in recent years increasingly large numbers of people in Western capitalist countries have left cities for the countryside to spend their vacations to live illustrates this point. China is a developing country in which disparities between city and countryside are currently very great. Consequently, it is understandable that most people yearn to live in cities, particularly large cities, but does this mean that urban construction is no problem for us? More than half of China's less than 200 million urban population is concentrated in 13 major cities. For example, the population of Guangzhou, Guangdong is greater than the total population of all cities and towns above the county level. When cities are densely populated, not only is balanced economic development impossible, but environmental pollution is fairly serious.

Economic benefit means comparison and evaluation of the consumption of live labor and materials, and results from labor in production after adoption of certain technical measures, technical programs, or technical policies. Generally speaking, economic benefits are high when output is high and costs low; otherwise economic benefits are low. This is the case in all societies.

The ecosystem is the unity of the biological system and the environmental system. The main environment here is the natural environment including light, heat, water, air, and soil. A good environment is a prerequisite for the existence and development of a biological system, and thus it is also the foundation for ecological balance. If the environment is damaged, the ecosystem will inevitably be damaged. For example, when the water system is damaged, conditions for the existence of fish will be spoiled bringing about the death of schools of fish. Conversely, deterioration of the ecosystem can lead to deterioration of the environment. The ecology and the environment are mutually promoting and mutually restrictive. Good ecological benefits are possible only where there are good environmental benefits. Conversely, good ecological benefits also help improve the environment.

Economic benefits are generally synonymous with ecological benefits and environmental benefits. Only when highly effective and fine quality ecological and environmental systems exist is it possible to have relatively high economic benefits. However, in actual practice, because of conflicts existing between long-range benefits and short-range benefits, and between benefits to parts of the whole and benefits to the whole, people lack a deep understanding of the dialectical unity between economic benefits and ecological and environmental benefits. For example, in the treatment of urban waste water generally an investment of 200 million yuan is required for a plant that is able to treat 1 million tons of waste water, and a daily expenditure of 30,000 yuan renminbi and 26,000 kilowatts of electricity are required as well. A city with a population of 1 million will require the building of six such plants in order to be able to treat the waste water that is discharged daily. This is doubtlessly a huge expense; furthermore, such an expense is in the nature of a nonproductive investment and expenditure. Consequently, when completely balanced national economic plans are drawn up, frequently there is vacillation about such plants, and they are finally "squeezed out." Such problems have not been given sufficiently serious attention. They may seem to save a little money for the present, but if this goes on for a longer period of time, the consequences will be dreadful to contemplate.

3. Several Problems That Must Be Watched In Bringing About the Unity of Ecological, Environmental, and Economic Benefits

It must be pointed out that bringing about the unity of three benefits requires synchronization of the protection of the ecological environment with the building of the national economy. In capitalist countries, because of the role of capitalist basic economic laws, the anarchic state of social production and pursuit by capitalists of maximum profits, capitalists do not care about common benefits for society. As a result, in capitalist societies the ecological environment is usually damaged first and then treated, and the treatment is also extremely limited. Ours is a socialist country in which building of the entire national economy must be planned and proportional. Furthermore, in order to avoid taking the tortuous road that capitalist societies take of polluting first and cleaning up later, we not only can but also must link protection of the environment with building of the national economy in order to protect the common interest of the whole society. Therefore, ecological benefits, environmental benefits, and economic benefits must be integrated and commonly considered in the development of industry, transportation, commerce, and agriculture alike. In order to increase economic benefits in agriculture, the following several problems must be watched for protection of the ecological environment.

First is the problem of a benevolent cycle in the agricultural ecology. The agricultural ecosystem is an integrated unit that includes the forest ecosystem, the grasslands ecosystem, the freshwater ecosystem, the marine ecosystem, the residential compound ecosystem, the village ecosystem, and the desert ecosystem. In order to preserve the benevolent cycle in the

agricultural ecosystem, it is necessary to preserve the benevolent cycle in the several aforementioned systems. It is necessary, as well, to coordinate the proportional relationships among each system, for if there is proportional imbalance, the entire agricultural ecosystem will be damaged. For example, forests are the major producers in the agricultural ecosystem. If attention is not paid to the planting of trees and afforestation, or if felling is emphasized and afforestation ignored, the effects on the entire agricultural ecosystem will be bad. Modernization of agriculture requires large scale farmland capital construction, large scale use of machines, pesticides, chemical fertilizers, etc., and this will have profound effects on the agricultural ecosystem. Consequently, maintenance of a benevolent cycle throughout the agricultural ecosystem and increase in economic benefits from agriculture will require all-around planning for mountains, waters, forests, fields, and roads, and for farming, forestry, animal husbandry, sideline occupations, and fisheries.

Second is the problem of water pollution. Development of modern industry has meant the discharge into bodies of water of large amounts of waste water, waste gases, and residues. This has led to either depletion of soluble oxygen or the enrichment of nutrients in bodies of water, which seriously threaten the growth of fish or may even lead to the death of large schools of fish. Use of industrial waste water or sewage from daily life above set standards for the irrigation of farmland may lead to destruction of the soil's structure or contamination of farm produce. In agriculture, too much destruction of forests to clear land for farming gives rise to soil erosion and damage to the quality of water in streams. Excessive use of pesticides and chemical fertilizers can also contaminate water quality. We have provided lessons in this regard. Some people say that unless promptly controlled, the silting of the mighty Chang Jiang that has taken place in recent years will change the Chang Jiang into "the second Huang He," within a short period of time. During the early 1970's, large numbers of fish species were killed off through the large scale use of extremely toxic pesticides, and "rearing of fish in paddyfields" became a meaningless expression. Thus, the key problem in assuring no or little pollution of bodies of water is prevention and control of the "three wastes" from industry, and protection of the benevolent cycle in agriculture. All that is required is serious attention to environmental benefits and ecological benefits and increased promotion of economic benefits will be inevitable.

Third is soil pollution resulting from use of chemical fertilizers and pesticides. At the present time prevention and control of crop diseases and insect pests to increase crop yields relies mostly on pesticides and chemical fertilizers. For example, more than half of the world's present increased grain output depends on chemical fertilizers and pesticides. Nevertheless, large scale use of chemical fertilizer can produce an ever increasing build up of acid radicals in the soil that make the soil acidic and lower soil fertility. Large scale use of pesticides produce very serious soil toxicity. This is because after pesticides have been used on crops, though a small amount can volatilize and another portion can be

absorbed by the plants, most ends up in the soil. Soil contamination with pesticides can damage the soil's granular structure. In addition, the washing by rains of soil that has been contaminated by pesticides contaminates surrounding bodies of water in turn, causing deterioration of the biological environment. The best way to solve the problem of soil acidification resulting from sole use of chemical fertilizers is to coordinate the proportions of nitrate, phosphate, and potash fertilizer used, while paying attention at the same time to the use of organic fertilizer and plowed under green manure. The main way to solve the problem of pesticides pollution is production of highly effective but low toxicity pesticides, limitations on the use of the amounts of highly toxic pesticides, breeding of new disease-resistant varieties, and intensification of multiple methods of prevention and control, particularly the use of biological prevention and control. Soil is an indispensable means of agricultural production. Only if it is used properly can its fertility be steadily increased. Therefore, only by linking soil use and soil nurture is it possible to improve the condition of the soil and to realize the unity of ecological benefits, environmental benefits, and economic benefits.

In the building of the rural economy, the linking of ecological benefits, environmental benefits, and economic benefits is no easy matter. In the actual process, this or that kind of conflict may sometimes occur; however, so long as we universally understand that doing a good job on the environment and the ecology "benefits the present generation and renders a service to succeeding generations," and establish a mentality of "creation of wealth for the people, and creation of wealth for succeeding generations," we can turn in a fine performance.

9432

CSO: 4008/360

ENVIRONMENTAL QUALITY

QUALITY ASSURANCE OF AIR MONITORING DISCUSSED

Beijing HUANJING BAOHU [ENVIRONMENTAL PROTECTION] in Chinese No 8, [Aug] 1984
pp 13-15

[Article by Cheng Xiaowu [4453 1420 2976]: "On Quality Assurance of Air Monitoring"]

[Text] The principal task of environmental monitoring is to obtain various kinds of information (such as intensity of pollution source, concentration of pollution material, meteorological, hydrological and geological conditions) for analysis, processing and collection in order to provide accurate and reliable monitored data and material (or known as information) for governmental departments to draw up and implement various environmental laws and regulations as well as for the overall development of environmental management work. Environmental monitoring is therefore essentially a process of information intake and output. Like the production process of products in other trades and professions, a quality assurance system should be established for this process by which we can ensure accuracy and reliability of monitored data and material.

In 1983 we adopted the hundred-mark rating system for the quality assurance of regular air monitoring at 10 regional (and municipal) stations in Shaanxi. With reference to the preliminary results obtained, I will put forward my humble opinion on the question of quality assurance of regular air monitoring and I request comments from colleagues in the field.

1. Quality Assurance System Consists of Quality Control of the Three Links of Sampling, Laboratory and Data Processing

Proceeding from the standpoint of system engineering, quality assurance is a large system formed by the three sub-systems of sampling quality control, laboratory quality control and data processing quality control. Each subsystem is in turn made up of many small systems which are independent of each other but which also interact. The flow chart of the quality assurance system is approximately as follows:

Flow Chart of Quality Assurance System of Regular Air Monitoring

Intake and Output of Environmental Information

Quality Assurance System of Regular Monitoring

Sampling Quality Control

Rational Layout of Monitoring Points	Setting Sampling Periods	Setting Sampling Time Durations	Calibration of Flow of Samplers	Responsibility System of Sampling Staff	Delivery of Samples
---	--------------------------------	--	---------------------------------------	---	------------------------

Laboratory Quality Control

Calibration of Measuring Instruments	Drawing of Standard Curves	Determination of Laboratory-Controlled Samples & Checking of Standard References	Determination of Samples	Storage of Samples
--	----------------------------------	---	-----------------------------	-----------------------

Data Processing Quality Control

Data Sorting & Statistics

Completion of Forms for
Submission to the Higher Level

Information Output

What is worth pointing out is that none of the three subsystems of the quality assurance system is indispensable. Moreover, laboratory quality control cannot be used to replace quality assurance; the two must not be confused. Concerning the characteristics of various environmental factors, there are those with general and specific characters. We should establish the quality assurance system on the basis of these characteristics.

2. Control of Sampling Quality

Control of sampling quality in environmental air monitoring is extremely important. The entire process of selecting monitoring points, collecting samples up to the delivery of samples between laboratories is called sampling quality control subsystem. The distribution, sampling period and sampling time durations are assumed to have been rationally determined here (actually some questions still remain with reference to current specifications of concerned documents which we will not discuss for the moment). In 1983 we stressed the two links of calibration of sampler flowmeters and sample validity, and required flowmeters to be calibrated prior to each sampling session. The method is to calibrate according to the actual flows of 0.3 liters per minute (to measure nitrides and oxides) and 0.5 liters per minute (to measure sulphur dioxide) as well as soap foam under loaded conditions (of absorption jars and oxidation tubes). This year we have calibrated a total of 399 instrument-times of which 163 are 0.3 liters per minute and 236 are 0.54

liters per minute (see Table 1 for the statistics). We have specified to indicate 5 percent positive or negative deviation of flow from the standardized flow to be correct and to indicate flows higher than the standardized flow as negative error and the reverse as positive error.

From Table 1 we can see that:

(1) Errors are considerable between flows and standardized flows which directly affect the degree of accuracy of the volume of samples. At Stations A and B, for example, the degree of accuracy was as low as 7 to 8 percent. Of all the inspected samplers, 24.56 percent have negative errors and 27.51 percent have positive errors which represent more than half of the total number. The highest positive error is 92.3 percent and the highest negative error is 80.00 percent.

(2) The rate of accuracy is 55.93 percent for 0.5 liter per minute flow calibration and 36.20 percent for 0.3 liter per minute. This is because when a flow of 0.5 liter per minute is used to monitor sulphur dioxide, obstruction to sampling is caused only by absorption jars; and when a flow of 0.3 liter per minute is used to monitor nitrides and oxides, obstruction to sampling is caused by both absorption jars and oxidation tubes. Naturally, the resistance overcome by the sampling dynamics of the former was small so that the sampling flow error is correspondingly small and the error of the latter is correspondingly large.

Another link that cannot be overlooked is the "validity rate of samples." Because of dynamic outdoor sampling, the power source, absorption solution and the delivery of samples as well as delay in sampling time can affect the validity rate of samples. They directly affect the sorting and collection of data. Consequently we must require the deduction of marks for validity rates which are below 95 percent.

The samplers inspected included three old and new models, of which there were 243 instrument-times for Model GS-III, 48 instrument-times for Model GS-II and 108 instrument-times for Model CD-I. The results of calibration show that there are different degrees of errors among the samplers of all models.

3. Laboratory Quality Control

Laboratory quality control includes intra-laboratory and inter-laboratory control. Intra-laboratory analysis of the precision and accuracy of data is the starting point of analyzing quality control. Quality control of inter-laboratory analysis can correct the system errors among laboratories, which provides reliability and comparability for the entire data analysis.

Current air monitoring in China as a rule includes the monitoring of the four items of sulphur dioxide, nitrides and oxides, total suspended particles and dust precipitation. Because there is strict control of the standard curves in various laboratories, it is the key to assuring the reliability and comparability among laboratories. As a result, we have controlled the various laboratory standard curves of sulphur dioxide and nitrides and oxides.

Table 1.

Sta- tion No.	Samplers Inspected	0.3 Liter Per Minute				0.5 Liter Per Minute										
		"-" Error Units (%)	No. Units	"+" Error Units (%)	Accuracy	"-" Error Units (%)	No. Units	"+" Error Units (%)	Accuracy							
A	GS-III	34	3	8.8	28	82.4	3	8.8	GS-III	34	4	11.8	10	29.4	20	58.8
B	GS-III	13	0	0	12	92.3	1	7.7	GS-III	13	0	0	3	23.1	10	76.9
C	GS-III	0	0	0	0	0	0	0	GS-III	14	0	0	0	0.0	14	100
D	GS-III	18	0	0	2	11.1	16	88.9	GS-III	18	0	0	0	0	18	100
E	GS-II	4	0	0	0	0	4	100	GS-II	4	0	0	0	0	4	100
	GS-III	15	0	0	6	40.0	9	60.0	GS-III	15	1	6.7	4	26.7	10	66.6
F	CD-I	12	3	25.0	3	25.0	6	50.0	CD-I	12	2	16.7	5	41.7	5	41.6
	GS-III	0	0	0	0	0	0	0	GS-III	42	6	14.3	20	47.6	16	38.1
G	GS-II	10	7	70.0	1	10.0	2	20.0	GS-II	10	8	80.0	1	10.0	1	10.0
H	GS-III	3	0	0	2	66.7	1	33.3	GS-III	3	1	33.3	1	33.3	1	33.4
	GS-II	9	6	66.7	3	33.3	0	0	GS-II	9	6	66.7	2	22.2	1	11.1
I	GS-III	6	0	0	3	50.0	3	50.0	GS-III	15	0	0	3	20.0	12	80
	CD-I	12	7	58.3	1	8.3	4	33.4	CD-I	20	8	40.0	0	0	12	60
J	GS-II	1	1	100	0	0	0	0	GS-II	1	1	100	0	0	0	0
	CD-I	26	16	61.5	0	0	10	38.2	CD-I	26	18	69.2	1	3.8	7	27.0
Total		163	43	26.4	61	37.4	59	36.2		236	55	23.3	49	20.8	132	55.9

In 1982 we assessed the computed factor of the standard curves of sulphur dioxide and nitrides and oxides in 10 regions (and municipalities) throughout the province, that is, the regression curves or the slope reciprocal ($1/b$) of $Y = bX + a$. There were 41 person-times for sulphur dioxide, of which 15 participants or 36.6 percent of the total qualified, and 45 person-times for nitrides and oxides, of which 9 participants or 20 percent of the total qualified. This shows that the degree of accuracy among laboratories throughout the province is very low.

The main reason of the disqualification of the computed factor is that there are problems in the three areas of glass apparatus calibration, spectrophotometer wave length calibration and preparation of standard solution. As a result, during the 1983 appraisal, we required all stations to report spectrophotometer wave length calibration data and standard curve data from two preparations of standard solution before monitoring. Of the 52 sulphur dioxide standard curves of computed factor, 85 percent were qualified and of the 52 nitride and oxide standard curves of computed factor, 90 percent were qualified, with the degree of precision within the range of less than 5 percent positive or negative deviation. In this way, the reliability and comparability among laboratories are effectively controlled.

4. Quality Control of Data Processing

To a certain degree quality control, of sampling and laboratory analysis is assured through the quality control of the two links mentioned above. But as information to be provided for government departments, it still needs to go through data processing, collecting and submitting reports to the higher level. This link demands promptness and accuracy. Therefore during the appraisal, we strictly required prompt submission of report forms, which must be tidy, clean and accurate in calculations. We strictly guarded against output of erroneous information or providing erroneous basis for evaluation and management work which would cause serious consequences. The results of the appraisal show that with these strict requirements, all stations made their reports according to the requirements of the provincial station.

5. Future Tasks

(1) Test and verify the rationalism and representativeness of current sampling points. At present, air monitoring points are based on the specifications of concerned documents and worked out at the discretion of various regions, while in evaluation and compilation of quality reports they have simply used the arithmetical mean of each monitoring point. Under the circumstances that we have not fully understood the structure of windy grounds in various cities, and as the rationalism, representativeness and actual conditions of air pollution of monitoring points vary considerably, to deal with these objective problems we will extensively use the "alkaline method to measure the sulphation rate" in various cities in order to understand the current state of air pollution in Shaanxi, test and verify the rationalism and representativeness of monitoring points. Moreover, we can accurately outline the scope of pollution concentration. We will also extensively use the "triethanolamine static filter elements to measure sulphur dioxide" to determine the average daily, weekly or even monthly concentration of nitrogen

dioxide in the air. In this way we can rather accurately understand the state of nitrogen dioxide pollution and the mechanism of its transference and transformation within each monitor region.

(2) Further improve intra-laboratory and inter-laboratory quality control. We will require admixing two laboratory controlled samples of self-prepared standard solution when we determine each batch of sulphur dioxide samples in order to control the determined accuracy of each batch of samples and to promptly report the determined results to the atmospheric office of the provincial station. Moreover, we will centrally distribute 0.2 percent roseaniline hydrochloride storage solution in order to improve inter-laboratory reliability.

9586
CSO: 4008/132

ENVIRONMENTAL QUALITY

BEIJING TRAFFIC NOISE REDUCTION METHODS DISCUSSED

Beijing HUANJING BAOHU [ENVIRONMENTAL PROTECTION] in Chinese No 5, 1984
pp 10-13

[Article by Li Bingguang [2621 3521 0342] and Chen Dingchu [7115 1353 2806]:
"How Beijing's Traffic Noise Can Be Lowered"]

[Text] 1. Introduction

The main source of urban environmental noise is noise from the movement of vehicles on city streets, which travel over a wide area, the affected areas having a high average noise level. A survey done in Beijing Municipality during 1979 and early 1980 showed an average 60 decibel (A) environmental noise level for the entire municipal area. This included 32 percent of the area affected by traffic noise in which the sound level averaged 67 decibels. (A). The main source of traffic noise is the engines, cooling fans, and intake and exhaust equipment on the vehicles themselves. When a vehicle is traveling at more than 60 kilometers per hour, tire noise is very pronounced. In general, with a doubling of vehicle speed, the noise level increases 9 decibels. Foreign countries have pretty well solved vehicle engine noise problems. Research on vehicle noise has centered mostly on a low noise design for tire treads. In addition to vehicle noise per se, traffic noise is also related to traffic volume, types of vehicles (the proportion of heavy and light vehicles), as well as road widths, nature of road surface, and facilities. Traffic volume on main thoroughfares in China's cities runs mostly from 300 to 1,500 vehicles per hour. When relative traffic volume doubles, the average noise level increases 2.5-3 decibels (A). This pattern is the same as in foreign countries; however, given the same traffic volume, China's traffic noise on urban streets is 12 decibels higher than in foreign countries. Not only is noise from vehicles themselves fairly high in China and the proportion of heavy vehicles larger, but the main reason for the high noise is narrow urban streets, poor facilities, and chaotic traffic control. Fast and slow vehicles plus pedestrians compete with each other on streets in urban areas, and the frequent pulsing horn sounding is a prominent reason for the high noise level. Horn blowing increases the average traffic noise level by 3-7 decibels, or the equivalent of a two to five fold increase in traffic volume. For this reason, in addition to continuing to improve vehicle noise, serious attention

to improvement of road environmental factors, strengthening of traffic control, and the curbing of horn blowing seem urgent.

During the last 3 years the Beijing municipal government has devoted extremely great attention to the traffic noise issue. Traffic regulations clearly restrict vehicle horn blowing, and simultaneous with solution to traffic safety, readjustments have been made in the routes and times for vehicles. In building roads, the municipal government has not only widened surfaces and increased the number of main thoroughfares, but has especially constructed roads that connect urban areas with the circumferential roads that circle the outskirts of the urban area. It has constructed overpasses, and it has built both a crosswalk and an underground walkway on the Fanhua municipal area thoroughfare. These actions have not only preliminarily solved the problem of traffic congestion but have also been remarkably effective in lowering the environmental affects of traffic noise. Comparison of traffic noise survey results from 171 measuring points on the same road sections in October 1979 and April 1983 are as shown in Table 1 and Table 2.

Despite an almost 50,000 vehicle increase in Beijing during the past 3 years for an average 5 percent increase in traffic volume along main thoroughfares (vehicles per hour), traffic noise has markedly declined. High noise average peak value L_{10} declined 3.4 decibels (A); equivalent sound level L_{eq} declined 2.2 decibels (A). This included a lowering of traffic noise on 58 percent of road sections, no change on 22 percent, and noise increase on 20 percent. Most of the road sections on which traffic noise was lowered were in the central districts of cities where population is dense. Most of the increase in noise took place on circumferential traffic thoroughfares around the edge of the urban area. These results are related to no passage of heavy vehicles through the central city as well as to improved road facilities and a reduction in horn blowing.

Table 1. Comparison of Beijing Municipal District Traffic Noise Measurement Results

Year and Month	Noise Level dB (A)				Motor Vehicles			
	L_{10}	L_{50}	L_{90}	L_{eq}	Total number of vehicles	Traffic (vehicles per hour)		
1979.10	77.4	67.4	60.6	72.5	109,552	643	1770	24
1983.4	74	66.7	60.6	70.3	156,106	673	1998	68

Table 2. Spacing of Beijing Municipal Area Traffic Noise (%)

Year and Month	%	L_{eq}					
		61-62	64	66	68	70	72
1979.10	%	0.7	2.2	7.8	11.9	10.6	21.9
1983.4	%	0.8	0.4	5.4	10.3	23.9	28.4
Year and Month	%	L_{eq}					
		74	76	78	80	82	
1979.10	%	15.4	16.5	6.4	2.4	3.4	
1983.4	%	26	4.5	1.3	/	/	

II. Ways to Lower Urban Traffic Noise

A. Restricting or prohibiting motor vehicle horn blowing

Figure 1 shows the effects of horn blowing on traffic noise. Increase in the frequency of horn blowing has caused marked increase in the noise average peak value L_{10} . For each doubling of the number of horn blowing times per minute, L_{10} increases 2 decibels, and the average value L_{50} increases 0.5 decibels. The equivalent sound level L_{eq} increases 1.2 decibels. On streets with a fairly large amount of horn blowing, traffic noise regularly increases from 3 to 7 decibels, which is equivalent to the noise from a two to five fold increase in traffic volume.

Figure 1. Effects of Horn Blowing on Traffic Noise Distribution (Traffic Volume is 420 Vehicles Per Hour)

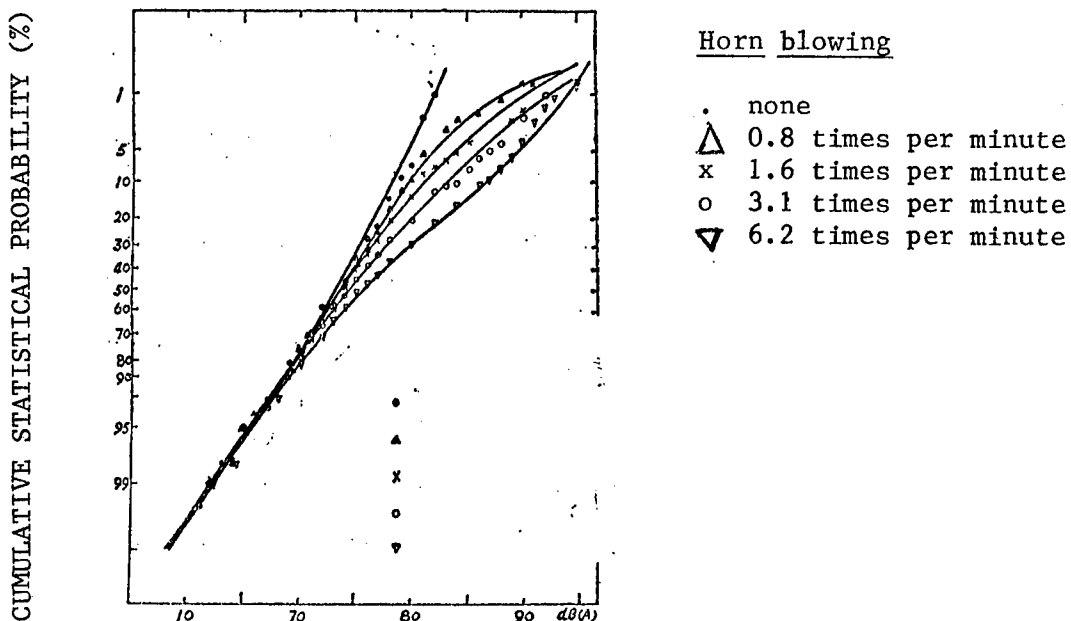

Beijing municipal traffic regulations provide for a prohibition against the use of loud horns, and motor vehicles have all installed low sound horns (2 meters in front of the vehicle and a horn noise no louder than 105 decibels). After having improved road facilities, it also strengthened control over pedestrian and bicycle traffic, and increased the number of road sections on which the sounding of motor vehicle horns is forbidden. No doubt, this further reduced the effects of vehicle horn blowing for greater environmental benefits.

B. Increase in Road Width

The effect of traffic noise is related to road width. Figure 2 shows attenuation of traffic noise with changes in distance. These are the results of actual measurements. When measurements were taken, traffic volume was approximately 800-1,000 vehicles per hour. A look at measurement results shows that when road width is doubled, the average noise level is attenuated by about 4 decibels (A), and attenuation of the average peak value L10 is more marked.

Figure 2. Traffic Noise Attenuation With Distance in Unenclosed Areas

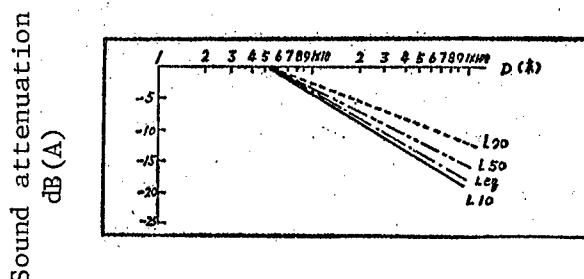

Road widening not only gains benefits in the natural attenuation of noise, but road widening also permits the building of multiple lane expressways on which fast and slow moving vehicles travel in different lanes. Not only does the unimpeded vehicular flow increase traffic volume, but the movement of fast and slow vehicles in their own lanes separated from pedestrians makes possible a prohibition against motor vehicle horn blowing. Table 3 shows traffic noise before and after widening of roads.

Table 3. Comparison of Traffic Noise Before and After Road Widening

Road Name	1979					1983				
	L10	L50	L90	Leq	Q	L10	L50	L90	Leq	Q
Yongdingmen West Road after widening from 12 to 21 meters	79	68	60	74	408	73.3	68.5	64.3	70.1	600
Widening of Donghuan North Road expressway	78	72	63	75.5	829	74.5	69	68	70.8	1160
Widening to 1,568 square meters of the area of Baizhifang Est Street	79	70	60	76	332	76.3	70.8	62.8	73.3	700
Widening from 23 meters to 25 meters of Qianmen West main Road	78	71	63	64.7	1000	73.5	69.5	65.5	70.8	1576
Chongwenmen West Main Street	80	74	63	78.8	1592	68.5	65	61	65.5	1576
Widening to 26 meters of surface of Luomashi Main Street	77	66	60	70.8	164	76.3	70.5	65.8	72.7	808
Widening to 28 meters of Gymnasium Road surface	76	67	58	72.4	608	69.8	64	58.8	66.4	500

Note: Q means traffic volume (Vehicles per hour)

C. Improvement in Traffic Environmental Conditions

1. Increase in One-way Streets

The number of one-way streets in the city was increased by 34. This not only solved the vehicle congestion problem, but also increased the volume of traffic going in one direction. Figure 4 shows comparative measurements before and after three thoroughfares in Beijing were made one-way roads.

Table 4. Comparative Measurements Before and After Traffic Thoroughfares Were Made One-way Roads

Road Name	1979					1983				
	L ₁₀	L ₅₀	L ₉₀	L _{eq}	Q	L ₁₀	L ₅₀	L ₉₀	L _{eq}	Q
Qianmer Dajie	85	77	70	802	572	75.8	70.5	66.5	73.4	408
Xinjiekou Beidajie	83	73	67	77.3	792	76.3	68.8	60.8	72.7	556
Xinjiekou Nandajie	82	73	65	77.8	712	76.3	69.8	61.8	72.5	632

This table shows clearly that despite a 12-30 percent decline in the total volume of two-way traffic (for a maximum 2 decibel decline in average noise level), the volume of one-way traffic increased 40-80 percent, while the average noise level declined 4.6-6.8 decibels. This was because one-way roads solved the problem of vehicle congestion on narrow roads and vehicle delays. As a result, the background noise value L₉₀ fell 3.5-7 decibels, and horn blowing in traffic jams was reduced, the noise peak value L₁₀ falling 5.7-9.8 decibels.

2. Increase in Roadside Railings and Lane Dividers

During the past 3 years, Beijing has erected railings and lane dividers totaling 6 kilometers in length along main roads. This has reduced the amount of pedestrian crossing of highways at will, and has speeded up the flow of vehicles, with a corresponding reduction in the frequency of horn blowing. Traffic noise has been reduced on these road sections. For example, measurements taken at Tiananmen in 1979 when there were no lane dividers showed traffic noise L_{eq} as 71 decibels (A) (traffic volume being 1,685 vehicles per hour). After installation of dividers, measurements taken in 1983 showed L_{eq} as 66.6 decibels (A) (traffic volume being 1,542 vehicles per hour). The traffic noise L_{eq} value fell about 5 decibels (A).

3. Erection Of Crosswalks and Use of Underground Walkways

In 1982, the Beijing Municipal Government and the traffic control department erected a crosswalk over Xidan Market Main Street, and put railings in place along both sides of the street to eliminate conflicts between vehicles and pedestrians. This not only assured both smooth traffic flow and safety, but also lowered traffic noise by reducing the frequency of horn blowing. Table 5 shows that not did traffic on this street increase 30 percent but the high noise peak value L₁₀ from horn blowing declined

6 decibels (A), and the equivalent sound level L_{eq} declined 4 decibels (A). Thus, either the crosswalk or the underground walkway erected on Fanhua roads merit promotion.

Table 5. Comparative Measurements Taken Before and After Use of the Street Crosswalk at Xidan Market

Place Name	1979					1983				
	L ₁₀	L ₅₀	L ₉₀	L _{eq}	Q	L ₁₀	L ₅₀	L ₉₀	L _{eq}	Q
Xidan Beidajie	83	72	64	78	540	76.8	71.0	67.5	73.9	720

4. Building of Crossover Intersections

Crossover intersections were built at many places on Erhuan Road. They not only moderated traffic jams in the urban area, but also avoided traffic noise caused by heavy vehicles passing through the central city. Not only did they increase the amount of traffic flow, but also completely solved the problem of horn noise from overtaking cars and vehicles taking the right of way. Table 6 shows the decline in noise on a street section following building of the elevated crossover at Xizhimen.

Table 6. Comparison of Traffic Noise Before and After Building of Crossover Intersections

Place Name	1979					1983				
	L ₁₀	L ₅₀	L ₉₀	L _{eq}	Q	L ₁₀	L ₅₀	L ₉₀	L _{eq}	Q
Fouchengmen Beidajie	74	68	63	70.2	1124	71.5	68.3	63	68	1500

To sum up improvements in main thoroughfare facilities presented here, marked improvements occurred in the increase in traffic volume and in lowering of noise. In the course of municipal government urban construction and planning, serious attention to improvement of road facilities not only can meet needs for the ever increasing development of urban traffic and transportation, but can also achieve marked environmental benefits in improvement of environmental noise.

III. Several Suggestions

A. Formulation and perfection of urban noise control regulations

Beijing Municipality's traffic ordinances contain regulations for the abatement of motor vehicle horn blowing. In addition, it is necessary to formulate environmental noise control regulations for the city to include traffic noise, work noise, construction noise, and noise in social life. Carrying out of these regulations will require strengthening of public security and judicial units, with noise control being put on the daily agenda of public order work.

B. Rational pattern of construction on both sides of roads

A rational pattern of construction on both sides of roads has a great deal to do with traffic noise disturbance to the public in the structures particularly to residents, to culture and education, and to government organizations. Only when the average sound level L_{eq} for interior environmental noise is no more than 45 decibels (A) is the environment suitable for daily life, study, thinking, and rest. At the present time, traffic noise on both sides of main thoroughfares is generally unsatisfactory. One thing that can be done is to widen roads to increase the attenuation of traffic noise. Another is a rational layout of the make-up of the groups of buildings that line the street, which can likewise reduce the effects of traffic noise.

Results of measurements show that high storeyed buildings along the street play a role in screening traffic noise from residential areas behind the groups of buildings, and they can lower noise by 15-20 decibels. A rational layout of the internal structure of high buildings that line the street can itself also overcome the effects of traffic noise. Today, structures on both sides of main traffic thoroughfares are 30 to 40 meters from the middle of the road. When traffic runs between 1,000 and 2,000 (vehicles per hour), the traffic noise outside buildings averages a sound level of approximately 65-68 decibels (A). With windows closed, the noise level inside buildings averages approximately 50-53 decibels (A), meaning that the interior environment is still quite noisy. During summertime when windows are open, in particular, it is even more noisy, interfering with people's normal activities and rest. Disturbance from traffic noise on the side of buildings facing the street may be solved by the use of large areas of glass windowed public galleries. Such a design is already being used in some high rise structures in Beijing. This not only assures ample sunshine and beauty in the city's appearance, but also reduces the effects of traffic noise. Experiments have shown the following noise comparisons for buildings that have and do not have such galleries: When gallery and building windows are open, the noise level in buildings having galleries is 6.5 decibels (A) less than in those not having galleries. When windows are closed, the noise level in buildings having galleries is 11 decibels (A) less than in those not having galleries. In general, for buildings having public galleries,

the noise level for buildings on the side where traffic noise is greater 48-51 decibels (A) in summer, and 39-42 decibels (A) in winter. Under present conditions, such an inside acoustical environment is considered fairly suitable.

C. Sensible selection of greenery for roads

In Beijing today, roadside greenery may be generally divided into sidewalk trees and green median strips. A welter of hedgerows, lawns, hedgerows, shrubs, and lawns exists. Analysis of sound attenuation from different kinds of greenery shows best results from a mixture of hedgerows, shrubs, and lawns. Chinese juniper hedgerows 1.2 meters high and 1 meter thick set back 5 meters from both edges of expressways with 6 meter high plantings of shrubs in between, with bushes such as yellow roses planted in spaces underneath can attenuate traffic noise by 4-7 decibels (A). The median green strip of the Sanlihe expressway in Beijing is like this.

9432

CSO: 4008/360

ENVIRONMENTAL QUALITY

ENVIRONMENTAL FORECAST IN SHANGHAI DISCUSSED

Beijing HUANJING BAOHU [ENVIRONMENTAL PROTECTION] in Chinese No 6, Jun 85 pp 7-9

[Article by Yang Xianzhi [2799 6343 2535] and Wu Lindi [0702 2651 1229]:
"Environmental Forecast in Shanghai"]

[Text] In order to keep abreast of the trend of development of Shanghai's environment in the future, coordinate the relationship between technological development and economic construction on the one hand and environmental protection on the other, and propose countermeasures for preventing the further deterioration of the environment and for improving environmental quality, under the leadership and support of the Ministry of Urban and Rural Construction and Environmental Protection and the Shanghai Municipal Scientific Committee and Environmental Protection Bureau, we have done some study on the following two topics involving forecast: "Forecast of Environmental Pollution in Shanghai Municipality" and "Shanghai's Environment in the Year 2000." At present, we shall summarize our methods as follows:

I. A Summary of Environmental Forecast

The technology of forecast truly became a branch of science only in the 20th century. In particular, in over 30 years since World War II, science and technology have developed rapidly, the newly-rising industries have emerged one after another, the cycle for knowledge updating and the cycle for product updating have become shorter and shorter, and an unusually acute competition has taken place on the capitalist market. Population growth, environmental pollution and the destruction of the ecological balance have appeared one after another. Thus, some industrially-developed countries have made use of modern scientific forecast technology to manage "large-scale engineering," "large-scale science" and "large-scale enterprises." Through practice, people have realized more and more that conducting scientific forecast of the future can prevent disastrous problems from happening.

Now, although there are already 200 to 300 methods of scientific forecast, only 20 to 30 are popularly used. According to their nature, we can generally categorize them into visible forecast method, trend extrapolation (including the mathematical model) and casual method (coherent analysis). Whether or not a forecast is successful largely depends on the forecast method selected. Generally speaking, the more meticulous and complex a forecast method and the

broader and deeper the factors considered, the more accurate the results of the forecast. What deserves our attention is that sometimes, adopting a simple method can also bring about satisfactory results, spending less time and paying a smaller price. Thus, in selecting a forecast method, we should also carry out a cost -- result analysis.

II. Procedures for Environmental Forecast

All scientific forecasts involve a dynamic process. Thus, the forecast procedure cannot remain unchanged. A sound forecast procedure should be a scientific system with scientific implications at every step and with reciprocal organic links. Furthermore, we must also have a whole set of scientific methods in order to guarantee that every step is scientific.

The procedures for environmental forecast is indicated by the following chart:

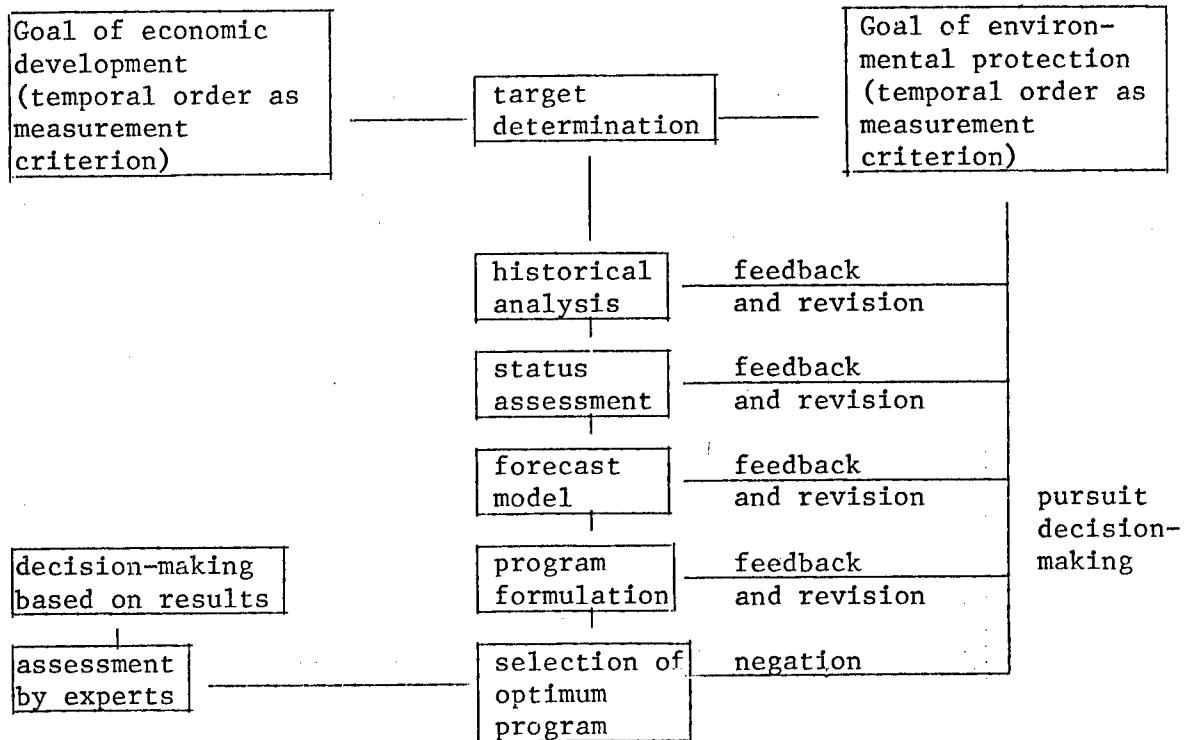

Although the environment is an organic whole which embodies designated capabilities, yet, to carry out scientific forecast on its future economic development and change, we must carry out both independent and reciprocal forecast from all different angles. Thus, like other scientific forecast procedures, environmental forecast in Shanghai is divided into eight basic procedures. At present, we shall take "a forecast of the environmental pollution in Shanghai Municipality" as an example and carry out analysis and explanation of each procedure.

1. Target determination

Target is the most important issue in forecast analysis. A wrong target will inevitably lead to wrong decision-making.

The so-called target refers to the anticipated results on the basis of forecast in a given environment and condition. It embodies three characteristics: (1) Its results can be measured; (2) its time can be fixed; and (3) its responsibility can be fixed. The overall demand for the study of environmental forecast in Shanghai is to take as the basic goal of quadrupling the gross value of industrial and agricultural output in Shanghai by 1990 and 2000. Then, in line with our country's basic situation and environmental characteristics, and in connection with the forecast and planning involving population, the society, the economy and science and technology, we shall carry out a combined qualitative and quantitative sketch of the trend of development of the environment in Shanghai in the next 10 to 20 years, propose countermeasures in preventing environmental deterioration and environmental improvement as well as programs for implementation, and clearly estimate the frequency of occurrence of environmental pollution, the volume of discharge, the volume of elimination and the investment in preventing environmental pollution during the period of planning.

2. Historical analysis

The review of economic growth and environmental trend in the past will give us the data base for future forecast. Temporal order analysis is a technology that studies the evolutionary relationship between the goal of forecast and its temporal process. Its characteristic lies in the assumption that the forecast of the previous trends of change of events will similarly lead to the forecast of future trends. Thus, by carrying out statistical analysis of the past temporal order, we can infer the future trends of change of events. In terms of the principle of what data to accept and what to reject, we must take into consideration the following four major characteristics:

(1) Verifiability: We must try our best to utilize existing statistical and investigative materials or conclusions which have already been strictly tested, in order to guarantee the reliability of our basic data and material.

(2) Quantifiability: We must try our best to make the targets of environmental forecast quantifiable.

(3) Comparability: We must have comparable materials from at home and abroad of the selected quantified targets and the assessment indices which these targets constitute.

(4) Wholeness: The system of targets of environmental forecast should embody the characteristics of wholeness in assessment in relation to the economic development of all sectors. In particular, it should take into consideration its effect of wholeness in the large system involving the entire municipality.

3. Status assessment

Influenced by the economic scale and the industrial structure, the frequency of occurrence of environmental pollution is the function of the population and economic density of a region. In order to seize upon the essence of a problem in forecast, we must first of all find out the source of pollution as well as carry out screening and assessment of the key sources of industrial pollution.

4. The model of forecast

The future forecast of the economic -- environmental system is generally conducted in two steps. The first step is to carry out warning-type forecast on the trend of development based on the assessment of historical and present conditions. The second step is to build a model of measurement and carry out countermeasure-type forecast based on goal and direction.

(1) Warning-type forecast

Warning-type forecast is also known as exploratory forecast or outline forecast. Its primary method is to adopt a model of a comprehensive urban system and carry out configuration by means of trend extrapolation. First of all, we will select industrial production, population, energy consumption and water consumption in a city as the factors of activity in the system, choose the statistical data from 1980 to 1982 as the data for the base years, consider the projected level of the energy model and population model of Shanghai Municipality, take the years 1900 and 2000 as the targets of forecast, and take the following assumption as the prerequisite: That is, if the speed of economic development continues to develop according to the situation around 1982 without increasing the facilities for eliminating pollution, then, we will be able to estimate the potential frequency of occurrence of certain pollutants according to the target of "quadrupling" the gross national output (here, it is a static forecast analysis) by the end of this century.

Calculating from relevant materials, the potential frequency of occurrence of sulphuric oxide, nitrogen oxide and smog in the air and organisms in the water in Shanghai Municipality will increase roughly 1.5 to 1.7 times from 1982 to 1990 and will increase roughly 2.0 to 2.3 times from 1982 to the year 2000. Thus, in the midst of technological progress, economic development and population growth, we must adopt all kinds of measures in a comprehensive manner to reduce the pollutants which are discharged into the environment and lighten the burden on the environment, so as to enable the people of Shanghai to have a basically comfortable environment which basically conforms to the health criteria.

(2) Goal-directed forecast

Goal-directed forecast is also known as normative forecast or detailed forecast.

In terms of a long-term comprehensive strategic planning of urban development, in order to put our hopes on development and on preventing pollution in the future, we must sufficiently seize upon the quantitative relationship between

economic activities and environmental protection, and set up a model for measurement accordingly. The experiences at home and abroad have told us that this model must accurately seize upon the process of environmental pollution and pollution elimination and at the same time expound the relationship between environmental protection and economic activities. In order to adapt to this goal, we should consider the following points in our model structure:

a. The relationship between economic activities and the frequency of occurrence of pollution; b. the relationship between volume of discharge and the volume of elimination of the target; and c. the relationship between the volume of pollution elimination and the necessary investment in pollution prevention.

For this purpose, it is more suitable to select a multidepartmental measurement model which takes as its basis the input-output system.

In accordance with the "Input-Output Flow Chart of the Major Products In Kind in Shanghai Municipality for 1981" and the "Input-Output Chart of the Values in Shanghai Municipality in 1981" compiled by the Shanghai Municipal Statistical Bureau, we can list the input-output flow matrix of the 97 specialized companies throughout the municipality. According to this matrix, we can calculate the unit discharge volume of all kinds of pollutants from 1980 to 1982 and the direct coefficient of these materials. Then, through finding out the Li-ang-jie-fu [phonetic] inverse coefficient, and adding to that this direct coefficient, we will be able to configurate the cumulative discharge coefficient. This model, which simulates the changes in the ultimate volume of supply of all kinds of materials in the economic development of Shanghai, is very useful in influencing the national income and the overall discharge volume of demand of the different periods, we can even simulate the changes in the economic structure. Furthermore, we can change the input-output index of the basic model to simulate the impact on environmental quality of the different levels of technological transformation and forms of energy utilization.

The building of this model, calculation and analysis of results are presently still under study, and will be presented as a special topic separately in the future.

5. Program formulation.

Through forecast analysis, in order to reach our selected goal, we must organize specialists from all fields to conduct analysis on the countermeasures, clarify the restrictive factors, and make use of our brains and technology to formulate all kinds of programs available for selection to be used as comparative targets for optimum selection.

6. Optimum selection of programs.

After we have formulated several programs available for selection, we must rely on "feasibility study" and "decision-making technique" in carrying out assessment at the stage of planning involves primarily the correlation matrix method and result analysis method which are used in determining the goal of the system.

Through analysis and assessment of the feasible programs, and comparing the advantages and disadvantages of the programs available for selection, we can either choose one or combine several programs into one program. This is an extremely complex task. This is because the program finally selected may not be the best with regard to every designated target. Often, it is extremely beneficial only to several major targets but is able also to take into consideration other targets. The decision-maker must therefore make use of the usefulness theory to weigh the pros and cons and select the optimum program in a decisive manner.

7. Appraisal by experts.

After we have determined the optimum program, we are approaching the end of the forecast procedure. Lastly, we should write separate reports on the results of the above study, compile a collection of relevant results of calculation, diagrams and appendices, and present this to the experts for appraisal. Through feasibility argument and technological and economic arguments, propositions for decision-making will be put forth.

8. Decision-making based on results.

The assessed results, together with the compiled materials, diagrams and documents, will be reported to the concerned higher-level departments and be used by the leadership as the basis for scientific decision-making. If there are more problems with the optimum program, we can retrace our steps and carry out feedback and revision step by step. If a higher demand is made on the goal of forecast, we can finally carry out pursuit decision-making.

III. Several Points of Realization

1. This topic of study must be advanced under the leadership of concerned leading departments of the municipality, and truly implemented, so that every result of our topic of study can be used in actual planning.
2. In our research work, we must adopt multi-disciplinary studies and effect an alliance among the natural science workers and the social science workers, and carry out study from the social, economic, technological and environmental angles and include them in a system model.
3. We must coordinate our research work with our local economic planning, urban planning and technological transformation, and truly include environmental protection work into our national economic plan.
4. In the process of study, we generally must comprehensively utilize all kinds of forecast methods, especially regression analysis, temporal order analysis, analysis of quantitative economic model, and input-output analysis. In respect to the measurement model, presently there are three models available for use, and they are: The economic-environmental measurement model used by Japan's Environmental Department, the economic-environmental quality input-output model used by Australia, and the system dynamics model used by the United States.

9335

CSO: 4008/222

ENVIRONMENTAL QUALITY

'SANSHENG' INDICATOR SYSTEM EXAMINED

Beijing HUANJING BAOHU [ENVIRONMENTAL PROTECTION] in Chinese No 5, 1984 pp 2-4

[Article by Li Jinchang [2621 6855 2490], Deputy Research Fellow, Technical Economics Research Center, Chinese Academy of Sciences: "Some Ideas About the "Sansheng" Overall Indicator System (Part 2)"]

[Text] 3. Design and Calculating Methods of the "Sansheng" Indicator System

(1) Design of the "Sansheng" Indicator System

As was said in the foregoing, the "Sansheng" indicator system is basically divided into three levels. The highest level is called the overall index of economic and social development. The second level is divided into a production index, a standard of living index, and an ecological index. For the third level, various individual indicator indices may be devised on the basis of actual needs. However, for the sake of ease in explanation and convenience in deriving calculations, only five specific items are assumed here under each of the indices. These items are for production, standard of living, and ecology. Certainly four levels might be constructed. For example, under the ecology index, an item on the area of erosion control or an item on urban environmental quality might be set up, with the density of sulfur dioxide in the urban atmosphere and the density of particulates in the urban atmosphere being put in the fourth level as subheadings under urban environmental quality. However, because of the shortage of overall data for study, only a simplification can be provided here. The following table explains the three level indicator system:

Overall Indices of Economic and Social Development

Production Index

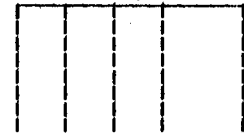

- Average Per Capita Social Gross Output Value (Yuan)
- Average Per Capita National Income (Yuan)
- Total National Financial Income (100 million yuan)
- Labor Productivity Rate for All Personnel in Enterprises Owned by All the People (Yuan per person per Year)
- Total number of Scientific and Technical Personnel in Units Owned by All the People Nationwide

Standard of Living Index



- Average Consumption Level of Inhabitants of the Whole Country (Yuan)
- Average Amount of Heat Derived from food Per Capita Per Day (Kilocalories)
- Average Per Capita Amount of Living Space in Cities and Towns (Square Meters)
- Percentage of Children of School Age Entering School (%)
- Number of Television Sets Owned Per 100 Population (Units)

Ecology Index



- Forest Cover Rate (%)
- Density of SO₂ in Urban Atmosphere (%)
- Density of Particulates in Urban Atmosphere (%)
- Percentage of Industrial Effluent Processed (%)
- Overall Utilization Rate of Various Wastes (%)

(2) Calculation Methods

There are two main points in the method of calculation for the "Sansheng" indicator system. The first is determination of base value. Either beginning year numerical values may be used to figure base value or target numerical values may be used to figure base value. The situations described above used target values to figure base value. Here, beginning year numerical values will be used to figure base value. The second is use of weighted units. This means ascribing a weighted figure for the degree of importance of each individual specific indicator index in the national economy and development of society. Then, weighted units are added to each indicator index at each level to derive the corresponding overall indicator index.

Now, let us assume that 1980 numerical values are the base value, and let us further assume the numerical values completed for the years 1981, 1982, and 2000, correspondingly weighting each item to derive the following individual calculations:

Production Index

Particulars	Weighted				
	Figure	1980	1981	1982	2000
(1) Average Per Capita Social Gross Output Value (Yuan)	0.20	860	900	970	2800
(2) Average Per Capita National Income (Yuan)	0.25	370	390	420	1230
(3) Total National Financial Income (100 million yuan)	0.15	1,085	1,089	1,124	4,340
(4) Labor Productivity Rate for All Personnel in Enterprises Owned by All the People (Yuan, person, year)	0.25	12,080	11,860	12,100	30,200
(5) Total number of Scientific and Technical Personnel in Units Owned by All the People Nationwide	0.15	528	571	626	2000
Production Indices After Weighting of Components	1.00	1.00	1.03	1.13	3.28

The production index in 1981 was:

$$\begin{aligned}
 & (1) \quad 900/860 \times 0.20 = 0.21 \\
 & (2) \quad 390/370 \times 0.25 = 0.26 \\
 & (3) \quad 1089/1085 \times 0.15 = .015 \\
 & (4) \quad 11860/12080 \times 0.25 = 0.25 \\
 + & (5) \quad 571/528 \times 0.15 = 0.16
 \end{aligned}$$

1.03

The production index in 1982 was:

$$\begin{aligned}
 & (1) \quad 970/860 \times 0.20 = 0.26 \\
 & (2) \quad 420/370 \times 0.25 = 0.28 \\
 & (3) \quad 1124/1085 \times 0.15 = 0.16 \\
 & (4) \quad 12100/12080 \times 0.25 = 0.25 \\
 + & (5) \quad 626/528 \times 0.15 = 0.18
 \end{aligned}$$

1.13

The production index in 2000 will be:

$$\begin{aligned}
 & (1) \quad 2800/860 \times 0.20 = 0.65 \\
 & (2) \quad 1230/370 \times 0.25 = 0.83 \\
 & (3) \quad 4340/1085 \times 0.15 = 0.60 \\
 & (4) \quad 30200/12080 \times 0.25 = 0.63 \\
 + & (5) \quad 2000/528 \times 0.15 = 0.57
 \end{aligned}$$

3.28

2. Standard of Living Index

Particulars	Weighted Figures	1980	1981	1982	2000
(1) Average Consumption Level of Inhabitants of the Whole Country (yuan)	0.30	227	249	266	770
Average Amount of Heat Derived From Food Per Capita Per Day (kilocalories)	0.20	2,590	2,670	2,780	3,300
Average Per Capita Amount of Living Space in Cities & Towns (sq mtrs)	0.30	4.5	5.0	5.6	8.5
(4) Percentage of Children of School Age Entering School	0.10	94	94	93	99
(5) Number of Television Sets Per 100 Population	0.10	0.5	1.5	2.7	25
Standard of Living Indices After Weighting of Components	1.00	1.00	1.27	1.57	6.95

3. Ecology Index

Particulars	Weighted Figures	1980	1981	1982	2000
(1) Forest Cover Rate (%)	0.30	12.7	12.7	12.5	20
(2) Density of SO ₂ Urban Atmosphere (%)	0.15	75	78	80	100
(3) Density of Particulates in Urgan Atmosphere (%)	0.15	15	17	13	80
(4) Percentage of Industrial Effluent Processed (%)	0.20	14	15	17	76
(5) Overall Utilization Rate of Various Wastes (%)	0.20	20	22	24	60
Ecology Index After Weighting of Components	1.00	1.00	1.06	1.07	3.16

Using the identical method as previously, results of calculations have been entered directly into the table.

4. Overall Indices

Particulars	Weighted Figures	1980	1981	1982	2000
(1) Production Index	0.40	1.00	1.03	1.13	3.28
(2) Standard of Living Index	0.30	1.00	1.27	1.57	6.95
(3) Ecology Index	0.30	1.00	1.06	1.07	3.16
(4) Overall Indices After Weighting of Components	1.00	1.00	1.11	1.24	4.35

The overall index for 1981 was:

$$1.03 \times 0.40 + 1.27 \times 0.30 + 1.06 \times 0.30 = 1.11$$

The overall index for 1982 was:

$$1.13 \times 0.40 + 1.57 \times 0.30 + 1.07 \times 0.30 = 1.24$$

The overall index for 2000 will be:

$$3.28 \times 0.40 + 6.95 \times 0.30 + 3.16 \times 0.30 = 4.35$$

The results derived from the hypothetical data show an 11 percent increase over 1980 for 1981, a 24 percent increase for 1982, and a 335 percent increase for 2000 in the overall index for economic and social development.

Were different areas, different provinces, different urban districts, or even different countries to use a similar indicator system and calculation methods, overall indices for economic and social development could be compared, making it possible to see the level of overall development and who is high and who is low.

4. Problems Requiring Study

The ideas presented here on integration of strategic goals, development models, and measurement criteria as well as on an overall indicator system for production, standard of living, and ecology overcomes some of the shortcomings of purely national production gross output value indicators and gross output value indicators for industry and agriculture also reflect and promote, in a fairly all-round way, overall growth of the national economy, the overall increase in the people's standard of living, and the steady improvement of the environmental ecology. They are also of positive significance at the same time in deriving the economic benefits, social benefits, and environmental benefits realized.

Nevertheless, perfection of this "Sansheng" indicator system will require a great deal of additional work and the carrying out of penetrating research. Several initial problems that have been preliminarily envisaged are as follows:

(1) For the specific indicators under production, standard of living, and ecology in the third level, just what categories should be set up or not set up as being most representative and as being most able to portray problems, and just how many categories would be reasonable and feasible requires careful study before making a determination. The five specific indicators provided above under production, standard of living, and ecology are just simple hypotheses, and they are neither complete nor totally rational. They are only to be used temporarily to show a train of thought.

(2) Postulation of weights is very important. The weighted figures assigned the production index, the standard of living index, and the ecology index are currently 0.4, 0.3 and 0.3 respectively, and they have been hypothesized informally to explain problems. Just what assignment of weights would be made in reality would have a bearing in understanding the relative importance of production, standard of living and ecology, and would also have a bearing on programs and policies.

Consequently, a rational proportional relationship among them and selection of appropriate weighted figures can be determined only through careful study and scientific calculations. Without it, yet other problems may arise. For example, using weights of 0.4, 0.3, and 0.3, because of the fairly small difference in the relative weighted figure for production, the weighted figure for ecology is relatively fairly large resulting in a not very rational situation of very little difference between the overall indices for Shanghai and Beijing versus the overall indices for Xinjiang and Tibet. As another example, since the initial base figure is very small for the number of television sets per 100 people under the standard of living index, if the weighted figure used is fairly small, a very great increase would occur in the standard of living index, and that would not appear to be very reasonable.

(3) The indicator system proposed here is for judging the level of development. How it should be related to and coordinated with assessment indicators used in enterprises are also problems requiring much study.

Therefore, it is proposed that quarters concerned devote further study to the "Sansheng" indicator system.

9432

CSO: 4008/360

ENVIRONMENTAL QUALITY

WATER QUALITY OF GEZHOUBA AREA DISCUSSED

Beijing HUANJING BAOHU [ENVIRONMENTAL PROTECTION] in Chinese No 6, Jun 85 pp 12-13

[Article by Wan Xiantao [8001 0752 3447]: "The Water Quality of the Gezhouba Reservoir Area of the Chang Jiang"]

[Text] The Gezhouba key water conservancy project, which may be rated as a first-class project in the world, is a magnificent undertaking in the history of water conservancy. On 4 January 1981, the dam was victoriously closed, cutting off the flow of the great river. On 23 May of that same year, the dam began to store water and display its usefulness.

During the period of water storage, as regards the quality of the reservoir water, whether or not there was pollution and whether or not the water can serve national economic construction, serve industrial and agricultural production and the people's livelihood are problems of concern for the people along the banks of the Chang Jiang as well as throughout the country. After several consecutive years of monitoring and investigation and study before and after the construction of the reservoir, we have collected and compiled data and materials showing the following trends of change in the quality of the reservoir water:

I. The contrast changes in several water quality targets of the reservoir area before and after water storage and in the upper and lower dam.

1. Changes of the heavy metals before and after water storage.

In the water body of the reservoir area, besides total iron, virtually all heavy metals stay below 0.1 mcg/liter or even fail to be detected. For instance, the average of mercury before water storage was 0.00015 mg/liter and 0.00011 mg/liter after water storage; (same below) copper was 0.0051 before water storage and 0.0018 after water storage; and lead was 0.00056 before water storage and 0.00041 after water storage. Arsenic was reduced by 35.6 percent, and total iron by 20.4 percent, after water storage.

2. Changes in the dissolved oxygen in the upper and lower dam.

The water body has a relatively good content of dissolved oxygen at above 4 mg/liter. Because pressure of falling water causes air to enter into the water body, the content is higher in the lower than the upper dam. The changes can be seen in the following chart:

Comparative Chart of the Content of Dissolved Oxygen (DO) in the Upper and Lower Dam Before and After Water Storage

Outflow (sec/cubic meter)	Water temperature °C	Upper dam (DO) (mg/liter)	Lower dam (DO) (mg/liter)	Remarks
5000	11.3	11.3	11.6	This chart is taken from the DO monitoring chart (average value) for 1982-1983 of the Yichang Monitoring Station of the Chang Jiang Water Resources Protection Bureau
10000 -- 20000	17.6	10.7	12.1	
30000	23.8	8.4	9.9	
40000	24.0	7.8	9.9	
50000	24.5	7.6	10.4	

3. Analysis of the heavy metals in the subsoil of the reservoir area.

The subsoil of the reservoir area contains relatively little lead and cadmium. This indicates that the heavy metals in the deposits in the water body is not sufficient to cause harm (see following chart):

Analytical Chart of the Heavy Metals in the Subsoil of the Reservoir Area

Cross section	Vertical line	Lead (mg/kg)	Cadmium (mg/kg)	Remarks
Huangbai He	Left	10.00	0.2375	1. The data is cited from the Changqing Line Monitoring Ship Analysis Office of the Chang Jiang Water Resources Protection Bureau. 2. The Atomic absorption method of analysis is used. 3. The time of analysis was the second half of May 1982.
	Right	7.50	0.2148	
San Jiang	Left	15.88	0.2912	
	Right	17.79	0.2867	
Hydrological channel of the water of the upper dam	Left	19.90	0.3115	
	Right	17.18	0.3932	
San Jiang	Right	13.31	0.2831	

II. Water temperature:

The changes in the water temperature are as follows: In the reservoir area, as a result of the comprehensive influence of a series of factors such as climate, hydrology, geography, solar radiation and the characteristics of the reservoir area, a definite structure of water temperature is formed. The average value of the water temperature from July 1981 to August 1982, recorded at the Yichang Monitoring Station of the Chang Jiang Water Resources Protection Bureau, was 18.1°C. After monitoring for the 2 consecutive years of 1981 and 1982, the "Changqing Line" Water-Quality Monitoring Ship also indicated that the water temperature was 18°C at the end of October 1981 and 23 to 24°C at the end of May 1982. The distribution across the vertical lines was even, with virtually no gradient and stratified changes. Generally, it is a mixed type of water temperature.

In addition, according to the analysis of the monitored results for 1981 and 1982 by the Yichang Water-Quality Monitoring Station of the Chang Jiang Water Resources Protection Bureau and of the monitored results for 1983 by the "Changqing Line" Water-Quality Monitoring Ship, the drying-up period for the floating organisms in the water was shortened, while the period of abundance of water was lengthened. However, the highest content from the cross section of most sections of the river was still below 1 gm/liter.

III. Changes in the chemical component of the water body.

From 1977 to 1978 before the construction of the dam, the Yichang Monitoring Station of the Chang Jiang Water Resources Protection Bureau carried out continuous cross section monitoring of the Maoercha section of the Nanjinguan upper reach, and indicated the following: The several major chemical targets in the water were quite good, with moderate acidity, a pH value of 7.9-8.1, DO at 8-12 mg/liter of water, and amino acid nitrogen at 0.035-0.045 mg/liter of water. Several toxic substances, such as volatile phenol (0.0012-0.00012 mg/liter), mercury, chromium and arsenic, were mostly not detected or below the state's surface water discharge criteria. After the dam was built, the "Changqing Line" Water-Quality Monitoring Ship also carried out continuous monitoring in the reservoir region, yielding moderate acidity, with a pH at above 7.5 and hardness at 7-8 German count. There was abundant dissolved oxygen (8-10 mg/liter). BOD was low, from a below 1 to a little above 1 mg/liter of water. COD was 1 mg/liter. TOC was also low. The content of organic chlorine farm chemicals was even smaller, at only under 1 mcg/liter of water. Mercury, arsenic, chromium, lead and cadmium were all below the surface water discharge criteria. The content of toxic phenol and cyanide was even smaller, at trace amount or at an undetected level. Conduction rate was lower than 200-300 micro-mho/cm. The inorganic mineral salt in the water body was also low.

Summing up the analysis and contrast of the components and elements in the water, the water quality of the Gezhouba reservoir area of the Chang Jiang was still good and was able to meet the needs of the national economic construction and water usage in production and livelihood.

Nevertheless, we must pay special attention to the signs of pollution of certain areas along the banks as a result of pollution discharge by the cities, towns, prefectures, industrial and mining enterprises, farmland and livelihood along the banks of the upper reaches of the reservoir area. After water is stored in the reservoir, there will be a large area of flooded land and hasty migration. As a result, a considerable quantity of organic substances will be dissolved in the water. In addition, with little building of farmland, orchards and forests at the upper reaches, the ecological balance will be slightly upset and water and soil loss will continue to increase. The application of farm chemicals and chemical fertilizer on large areas of farmland and orchards and the use of synthetic detergents by the masses of people in the upper reaches, too, will result in the pollution of the water body and the increase of nitrogen and phosphorus nutrients in the future. We must attach importance to this matter now! To carry out proper water resources protection planning at the upper reaches and along the banks of the reservoir area, we should launch economic construction and environmental protection in a synchronous manner. The upper reaches and the banks along the reservoir region must set up and perfect the system of water resources protection laws, conscientiously implement the "Environmental Protection Laws" (trial version) and the "Regulations in the Protection of the Water Resources of the Chang Jiang," which were formulated in 1982. We must strengthen our supervision and management of the major sources of pollution, strictly control the occurrence of new sources of pollution, strengthen the monitoring and supervision of the water quality of the reservoir area as well as the water quality of the upper reaches, conscientiously implement the "Regulations for the Work of the Water-Quality Monitoring Network of the Chang Jiang Water System," and form a network of monitoring stations in order to bring about unified, standardized and scientific monitoring and analysis. When major incidences of pollution occur along the banks, we must issue warning without delay and adopt emergency measures of control accordingly. The various cities and towns as well as industrial and mining enterprises along the river must adopt practical and realistic measures to control industrial and domestic sewage, stem out the discharge of toxic waste water, and implement strict supervision in these matters. We should strengthen the work of water and soil preservation along the river, strictly prohibit random felling of trees and clearing of grass coverings, oppose blind reclamation and maintain a benign ecological cycle. We must strive to control the further deterioration of water quality and gradually improve, and even restore, the water quality during the "Sixth 5-year Plan" period.

9335

CSO: 4008/222

ENVIRONMENTAL QUALITY

EFFECTS OF INDUSTRIAL POLLUTION ON A NORTH CHINA LAKE EXPLORED

Beijing HUANJING BAOHU [ENVIRONMENTAL PROTECTION] in Chinese No 5, 1984
pp 16-19

[Article by Wang Zhuangjing [3769 5445 7234]: "Effects of Industrial Effluent on Aquatic Organisms in Baiyangdian"]

[Text] Baiyangdian is the largest freshwater lake in the Hai River basin where shallow lakes dot the landscape and ditches crisscross the terrain leading to the Jiu River above and connect with the Beidagan below. The waterland area is wide and the waters shallow, which is extremely suitable for the propagation of aquatic resources such as fish and shrimp. Baiyangdian plays a major role in the rearing of freshwater fish and in providing aquatic products to Tianjin.

Historically Baiyangdian has been so clear as to be able to see the bottom 200 to 300 centimeters down. Except for a small amount of current near the river mouth where it flows downward into the river, its waters are calm elsewhere over a vast area. Baiyangdian's water temperature is fairly ideal; From June through September its water volume increases; it contains plentiful nutrients, and large amounts of salts and organic matter enter the lake area promoting the reproduction of plankton, which provides plentiful food for fish. The fish are mostly grass carp [*Cenopharyngodon idellus*], black carp [*Mylopharyngodon piceus*], silver carp [*Hypophthalmichthys molitrix*], variegated carp [*Aristichthys nobilis*], and common carp [*Cyprinus carpio*]. More than 30 aquatic organisms proliferate in the lake area, reeds being the most important crop that is farmed. Others include lotus root, water chestnuts and jitou [7741 7333], and *Potamogeton distinctus*.

Baiyangdian formerly connected with the Zhu He at the top and flowed into the Bohai, so it had both fish species that reproduce in lakes and fish species that migrate to spawn or travel upstream into the lake. In 1958, 54 species in 16 families were recorded; in 1976, 35 species in 12 families were recorded; and August 1980 statistics showed 40 species in 14 families. Comparison of data shows the species in which greatest reductions occurred to have been those swimming upstream such as junyu [? 7625], eels, and silver carp, as well as certain species that migrate to spawn such as black carp, triangular bream [*Megalobrama terminalis*], and grass carp.

Most of the grass carp, silver carp [*Hypophthalmichthys molitrix*], and triangular bream seen in the lake today have been artificially incubated. Members of the carp family are dominant among the naturally propagated species.

A substantial number of the phytoplankton found in Baiyangdian are natural food for fish. Reserves of benthon and aquatic plants are also fairly plentiful; however, as the discharge of effluent in the upper reaches steadily increases and water pollution becomes increasingly serious, and as the material cycle changes as a result of the effects of the physical and chemical environment in the waterlands, the biological activity of fish is also affected, producing changes in the flora and fauna with a decline in output. Changes in water conservancy conditions also engender a certain effect on the ecological environment. We conducted an initial survey of Baiyangdian's water environment from early April through July 1981 to make a preliminary analysis and exploration of the effects of pollution by industrial effluent on the ecological activity of fish as well as resultant changes to physiological functions, and changes to flora and fauna.

1. Baiyangdian Water Quality

(A) Pollution entering the shallow lake water system

1. Sensory organ characteristics. Most of the effluent discharged into the Fu River from Baoding flows into the lake and spreads out in all directions. Both the river channel and the surface of the lake are dark brown in color, turbid, have a transparency of only about 0.1 meters, and give off a fermenting stench. From Sainan, Guangdian Zhangzhuang, Wangjiasai, and Guolikou stretching toward Liuzhuangzi, Quantou, and Datianzhuang, the water changes to a murky brown color and transparency increases to about 0.5 meters. Virtually no stench is evident. Outside this limit, the water gradually becomes clear, and underwater plants thrive.

2. A survey conducted from 1979 through 1980 shows that as a result of improper design of the Tan River effluent catchment, it is impossible to separate clear and polluted water. In fact, only a portion of the polluted water enters the Tang River effluent catchment, and most of it continues to flow into the lake via the Fu River. Baoding Prefecture discharges 450,000 tons of industrial effluent daily, 420,000 tons of which flow directly into rivers, 180,000 tons of it flowing into the Fu River. This effluent contains numerous kinds of toxic materials, most of which are organic pollutants. Pollutants in the Fu River account for 49.63 percent of the pollution load for the whole prefecture. A look at detection values shows COD at more than 11 ppm, and a maximum detection value of 152 ppm for an average 40 ppm, which is 10 percent above standards. DO is below 4 ppm, a detection value of 0 occurring in more than 40 samples. The detection value for sulfides ranged from 0.677 to 1.4 ppm. The DO at an observation kiosk more than 20 li below Baoding was 73.70 milligrams per liter. Dissolved oxygen could not be detected, and phenol content was twenty-sixfold

higher than the standard for surface water. No trace of water organisms was found. Effects of pollution on Baiyangdian have been great; thus a clean up of the Fu River is the key to improvement of aquatic resources in Baiyangdian.

The industrial region located in the counties through which the upper reaches of the Juma River flow, the section running from Futugu to Zijingguan, is polluted by industrial effluent from machine, chemical, and metallurgy industries, and the river's waters are turbid and bubbly. Monitoring results show the river water to be polluted with heavy metal ions. Various heavy metal pollutants including copper, lead, zinc, and cadmium were found. The Liuli River, a tributary of the Juma River flows through a petrochemical region of Beijing where it becomes polluted with petrochemical industrial effluent. It's ammoniacal nitrogen content is even higher than in the Fu River, and its arene and petroleum content is higher than permissible limits for surface water. Residents report that the water in Baigou River section at the lower reaches of the Juma River smells of petroleum, that the surface of the river frequently has an oil slick, and the fish has a peculiar taste.

The Zhulong River basin contains mostly cyanide, volatilized phenol, and sulfide pollutants followed by organic pollutants. The effluent that enters the upper reaches of the Tang River basin consists mostly of heavy metal pollutants including cadmium, copper and lead pollution load of approximately 25 percent.

Printing and dyeing and textile waste water makes up the dominant pollution of the Xiaoyi River. During the dry season, the river water looks blue and contains a large quantity of bubbles, which pollute a part of the waters of the Baiyangdian.

(B) Statue of Pollution of Baiyangdian

Inasmuch as pollution of Baiyangdian stems largely from the entry of industrial effluent from Baoding City via the Fu River, organic pollution predominates. Lake region pollution is very much highly concentrated, as well as transient and partial in nature. The area of serious pollution is near the mouth of the river at the entrance to the lake particularly in the stretch from the mouth of the Fu River to Nanliuzhuang. The lake area pollution may be divided into three types as follows: (1) The heavily polluted area from Nanliuzhuang and Liuzhuangzi to the mouth of the Tang River, which is caused by effluent from Baoding. (2) The area from Caiputai to Zaolin in the southeastern part of the lake, which is a lightly polluted area. (3) The water area of Laowangdian between the two aforementioned areas where pollution is from medium to light.

During winter and spring, pollution is serious. Summer and autumn are the growing seasons for organisms as well as the high water season when the volume of water is large and the river's power to purify itself is strong, so evidence of danger is not conspicuous.

During winter and spring the detection values for lake water COD, BOD, and ammoniacal nitrogen are extremely high because of the entry of pollutants into the lake from the Fu River, and the concentration of oxygen consuming organic matter is high. This causes a reduction of DO in the body of water. During winter and spring, a layer of ice covers the lake, so the water surface is separated from the area making oxygen replenishment difficult. In the water beneath the ice, large amounts of oxygen consuming organic matter rots, and the consumption of oxygen in the water causes a serious lack of oxygen in the water, with the result that fish suffocate and die. The winter and spring K value of the pollution index is 0.45-0.50. This is the time of year when pollution is most serious. By summer and autumn, when air temperature is high and the metabolism of living creatures is in full swing, the oxygen replenishment process is strengthened, and purification is greater. Then during the high water season when the volume of water is large, the pollution index relatively declines to below 0.30, and even the Fu River is only lightly polluted.

II. Pollution of the Baiyangdian Water System and Freshwater Creatures

(A) Effects on the kinds of fish

Gradual deterioration of living conditions for aquatic creatures and fish accompanies pollution of the Baiyangdian. Changes take place in the kinds of numbers of creatures in the body of water, and species with poor ability to live in pollution gradually disappear. Finally those species with strong ability to live in pollution remain. These fish types that are strongly tolerant of pollution have auxiliary respiratory organs suiting them to low oxygen conditions; so they are able to survive. In addition, their competitors for survival have vanished, so they expand their numbers through a large amount of reproduction. Thus, within certain limits, the more severe the pollution, the more singular the kinds of creatures found in the water, and the greater the numbers of individual species. A look at the present make-up of fish species and ecological characteristics in Baiyangdian shows most to be species that tolerate low oxygen, namely common carp, crucian carp, and catfish, with members of the common carp family holding absolute predominance at 62.5 percent of the total. Numerous valuable fish species are on the verge of extinction. This situation is basically similar to the make-up of lake fish in north China. Now let us compare the make-up of fish species surveyed by the Animal Research Institute of the Chinese Academy of Sciences in 1958 with the make-up of fish species surveyed in 1980 by the Hebei Aquatic Products School.

(See table below).

Comparison of the Make-up of Various Kinds of Fish in Baiyangdian

Family	Number of species		Percentage	
	1958	1980	1958	1980
Carp Family	34	25	62.96	62.5
Loach Family	4	2	7.41	5
Catfish Family	1	1	1.85	2.5
Leiocassis Family	3	1	5.56	2.5
Families other than carp type family	12	11	22.22	27.5
Total	54	40	100	100

Quoted from survey data collected by the Animal Institute of the Chinese Academy of Sciences and the Hebei Aquatic Products School

(1) Toxic effects on fish and shrimp of polluted water

Research has shown polluted water to have definite toxicity for various kinds of fish and shrimp. Raw pollutants caused most fish and shrimp to die within 14 hours. Tolerance varies among fish species, zhi [2809] shrimp, tiger fish [5706 7625], and Hemibarbus maculatus Bleeker being most sensitive, taking only 5 minutes to die. Oryzias latipes, Monopterus albus, and Wuliyuanweiji fish [3527 9661 0955 1442 6060] have greatest tolerance being able to last for from 2 to 3 days. The death of fish and changes in their quxi [0575 4762] result mostly from the lack of oxygen in polluted water. However, those who have fairly strong resistance to pollution, and fish that have the distinctive habit of protecting their young continue to develop and their output does not decrease.

Water pollution affects ovulation and speed of growth of fish such as silver carp, Chinese perch [Sinperca chuatsi] (Mandarin fish and Migu [1378 ?]). The public says that freshwater shrimp and river crabs dislike polluted water most, and as soon as they encounter slightly polluted water, they climb up on the bank; they die at once in seriously polluted water. Furthermore, gill rot and red skin disease [6375 4122 4016] has been discovered in recent years.

(2) Status of mercury pollution on Baiyangdian fish

Both Baiyangdian and Guanting Reservoir are key nationally protected water sources. Nevertheless, they have been lightly polluted with mercury. The degree of mercury pollution of fish varies with the diet and age of fish. The mercury content of fish's bodies derives mostly from the food chain. Therefore, fish having different diets have different degrees of mercury pollution. Survey and analysis have shown that fish eating snakeheads and catfish have the highest mercury content. Those having a medium amount of water are crucian carp and common carp that eat benthon and decomposed plant matter. Those having least mercury are junyu, silver carp, and grass carp that eat each water plants (aquatic vascular bundle plants) and floating plants.

Phenol is a protoplasmic toxin that penetrates the bodies of living organisms fairly easily, and all parts of the nervous systems of animals are particularly sensitive to phenol compounds. Observation of experiments has shown that when grass carp are put into a solution containing phenol, they first become very excited, exhibiting frenzied swimming and shaking after which their activity gradually weakens; they become dazed, and finally they die.

(B) Effects on Aquatic Plants of Pollution in Baiyangdian

Water pollution also affects changes in aquatic plants. Since distances from sources of pollution vary and the degree of pollution differs, changes in plants also vary. *Antirrhinum majus* and *hydrilla verticulata* exist everywhere in the lake, but because of the serious pollution, there is less of it near the big bridge at Nanliuzhuang and the big bridge at Anxin. In areas fairly close to sources of pollution, no communities of *xingcai* [2622 5475] are found. Replacement of the composition of floating plant communities also reflects changes in environmental factors and is closely linked to the status of water pollution.

The plants in various ecotypes also differ in their tolerance of pollution. Rivers and lakes that are fairly close to sources of pollution are murky, not very transparent, and their waters have a foul odor. Submerged plants cannot live in them. After having been soaked in polluted water, the stems of reeds become dark and brittle, and reed quality and output are impaired.

The daily discharge of effluent from industries and mines into the Baiyangdian basin amounts to 629,000 tons. In addition to the toxic effect of this effluent on aquatic organisms, there is also a mechanical effect and an effect on the air over the surface of the lake. When the material suspended in the polluted water settles, the accumulation of debris on the bottom brings about death or changes in organisms at the bottom causing a great decline in the number of living creatures there. If the suspended materials contain toxins, they also give rise to chemical toxicity. The suspended matter in some industrial effluent adheres to the fish's gills where it impairs their breathing, and the fish suffocate. In addition, the solutes and suspended particles in polluted water gasify strongly as

the result of the action of microscopic organisms, and the oxygen in solution in the water is depleted very quickly. If the water contains readily gasified inorganic material, this process proceeds even more intensely. Because of the dramatic lowering of the water's oxygen content and the release of toxic gases and hydrogen sulfide (hydrogen sulfide is a strongly toxic gas for aquatic creatures), large numbers of living things in the water die. Pollutants are also dangerous to aquatic creatures because of their chemical properties. Harmful materials in most industrial effluents can poison numerous bacteria, plants and animals. When there is a certain amount of harmful materials in a fairly small body of water, virtually all life is killed. If the water contains molybdenite, the fish will contract eye diseases and the gills of young fish will be damaged. If the water contains cyanide, lead salts, copper salts, or phenol, all of which are toxic to living organisms, even if they are not of sufficient concentration to cause death, they will damage the physiological functioning of living things. Though toxicity for living organisms of some toxic materials is not immediately apparent because of their minute amounts, they can accumulate in the bodies of organisms causing fish and other aquatic organisms to lose their accustomed value as food. Polluted water also pollutes ground water and water used for agricultural irrigation, thereby spreading the polluted area. Elimination of pollution and protection of Baiyangidan is a problem in urgent need of solution.

9432

CSO: 4008/360

AUTHOR: WU Bincai [0702 2430 2088]
QU Yuxin [4234 3558 1800]
LIU Hengchuan [0491 1854 2796]

ORG: All of the Department of Chemistry, East China Normal University

TITLE: "Synthesis of a Class of New Color Reagents, Bromophosphono Bisazo Derivatives of Chromotropic Acid, and Their Color Reaction with Rare Earth Elements"

SOURCE: Beijing HUAXUE SHIJI [CHEMICAL REAGENTS] in Chinese No 5, 28 Oct 85 pp 269-272

TEXT OF ENGLISH ABSTRACT: Fourteen asymmetrical bromophosphono bisazo derivatives of chromotropic acid have been synthesized and the behavior of their color reaction with rare earth elements has been studied in detail. The relationship between structure and behavior of the reagents was investigated.

This kind of color reagent reacts to rare earth elements with high acidity, high sensitivity, large contrast and good stability. Many reagents show excellent analytical behavior with rare earth elements in acidic medium, better than do analogous chlorophosphonazo derivatives, and can be used as reagents for the determination of total, cerium-subgroup and yttrium-subgroup content of rare earth elements.

9717

CSO: 4009/148

AUTHOR: JIN Xigao [6855 3588 7559]
LI Huiming [2621 1920 7636]
et al.

ORG: Both of the Institute of Chemistry, Chinese Academy of Sciences,
Beijing

TITLE: "Analysis of the Harmful Products of Polyvinyl Chloride During
Thermal Processing by Using PGC-MS"

SOURCE: Beijing ZHONGHUA YUFANG YIXUE ZAZHI [CHINESE JOURNAL OF PREVENTIVE
MEDICINE] in Chinese No 6, 25 Nov 84 pp 321-323

TEXT OF ENGLISH ABSTRACT: A pyrolyzer was utilized to simulate the thermal processing conditions of plastics and was connected to a gas chromatograph-mass spectrograph system. From the pyrograms and mass spectra of polyvinyl chloride at the processing temperatures (150-200°C) and periods (5-20 min), certain toxic thermal decomposition products, such as benzene, methyl chloride benzene and monomer and cyclic dimers of PVC, were found. The effect of temperature and stabilizer on the yields of the toxic products was also studied. In the combined study of the determination of the product concentrations in the air of the workshops and in workers' blood and urine, PGC-MC was applied to understand the pollution problem caused by the thermal processing of PVC.

9717

CSO: 4009/163

AUTHOR: XU Dewei [1776 1795 4850]
WANG Xianxiu [3076 5343 4423]
ZHANG Qingying [1728 1987 5391]

ORG: XU and WANG both of Changchun Institute of Physics, Chinese Academy of Sciences; ZHANG of Changchun Institute of Optics and Fine Mechanics, Chinese Academy of Sciences

TITLE: "Experimental Investigation of Prism-Grating Couplers"

SOURCE: Beijing DIANZI XUEBAO [ACTA ELECTRONICA SINICA] in Chinese No 6, Nov 84 pp 33-36

TEXT OF ENGLISH ABSTRACT: A grating with 1200 lines/mm has been fabricated by a diffraction grating ruling engine on the surface of a polished optical glass (ZF₇) prism for the first time. This device is usually called a prism-grating coupler. It has many novel characteristics, and the wave-guide mode can be effectively excited in the film even when the index of the film is higher than that of the prism.

AUTHOR: ZHOU Ninghua [0719 1337 5478]

ORG: Beijing Institute of Aeronautics and Astronautics

TITLE: "Effects of the Op Amp Finite Gain and Bandwidth on the Performance of Switched-Capacitor Filters"

SOURCE: Beijing DIANZI XUEBAO [ACTA ELECTRONICA SINICA] in Chinese No 6, Nov 84 pp 48-55

TEXT OF ENGLISH ABSTRACT: A new method for establishing the Z domain equivalent model of a non-ideal op amp is presented. The Z domain transfer functions of non-ideal integrators based on the forward difference and the backward difference transformations are derived as two examples. Using this method, the computer simulation and experimental verification of a typical decoupled biquad second-order bandpass SCF are conducted. This method can be extended to solve the design problems of many different kinds of high order SCF.

AUTHOR: CHENG Huansheng [2110 3562 3932]
WANG Jitao [3769 1323 7118]
ZHOU Zhuying [0719 4591 3379]
et al.

ORG: All of Fudan University, Shanghai

TITLE: "Analysis of Hydrogen Content in Plasma-deposited Silicon Nitride Films"

SOURCE: Beijing DIANZI XUEBAO [ACTA ELECTRONICA SINICA] in Chinese No 6,
Nov 84 pp 63-67

TEXT OF ENGLISH ABSTRACT: The hydrogen content in the silicon nitride films plasma-deposited at 20-560°C has been determined by the He-H elastic recoil detection technique combined with Rutherford Back Scattering and the nuclear reaction $^{16}\text{O}(d,p)^{17}\text{O}$. The effects of substrate temperature on hydrogen quantity, Si/N ratio in films, refractive index and density of films are presented. The correlation between the hydrogen content and BOE etch rate is given.

9717

CSO: 4009/141

AUTHOR: HUANG Haoping [7806 8510 1627]
ZHU Renxue [2612 0088 1331]

ORG: Both of Changchun College of Geology

TITLE: "Interpretation Method of the Time-Domain AEM Response Above a Conducting Spherical Orebody with Permeability"

SOURCE: Changchun CHANGCHUN DIZHI XUEYUAN XUEBAO [JOURNAL OF CHANGCHUN COLLEGE OF GEOLOGY] in Chinese No 1, 1984 pp 107-116

TEXT OF ENGLISH ABSTRACT: An interpretation method is described for the time-domain AEM (airborne electromagnetics) response above a spherical conductor. The formulations of the time-domain AEM response of the sphere in a dipole field are developed. The responses of different spheres were computed with the parameters of a Chinese-made impulse-type AEM system. The diagrams of interpretation presented from the computer results can be used to solve two major problems. The first is to interpret an isolated response measured by the AEM system so that depth, radius and conductivity of the conducting sphere will be provided. The second is to estimate amplitude, width and decay characteristics of the response caused by different spherical conductors. Therefore, the diagrams are useful for the AEM work.

9717

CSO: 4009/133

18 April 1985

AUTHOR: GUAN Yingnan [7070 4481 3948]

ORG: Northeast Institute of Technology

TITLE: "A Branch-Constructing Algorithm for Extreme Vertices of the Mixture Convex Polyhedron and a Modified CONSIM Algorithm"

SOURCE: Beijing YINGYONG SHUXUE XUEBAO [ACTA MATHEMATICAE APPLICATAE SINICA] in Chinese No 3, Jul 84 pp 328-333

TEXT OF ENGLISH ABSTRACT: In this paper, a branch-constructing algorithm for extreme vertices of the mixture convex polyhedron with lower and upper bounds is given. By use of pseudocomponent transform, it can be transformed into a mixture convex polyhedron with upper bounds only. A branch-constructing algorithm for the polyhedron is given. Based on the algorithm, a modified CONSIM algorithm for the mixture convex polyhedron with multicomponent constraints is given.

AUTHOR: WANG Gaoxiong [3769 7559 7160]
JING Zhujun [0064 4554 0689]

ORG: WANG of Zhongshan University; JING of the Institute of Mathematics,
Chinese Academy of Sciences

TITLE: "Qualitative Analysis of a Mathematical Model for Respiratory
Process in Bacterial Culture"

SOURCE: Beijing YINGYONG SHUXUE XUEBAO [ACTA MATHEMATICAE APPLICATAE SINICA]
in Chinese No 3, Jul 84 pp 340-346

TEXT OF ENGLISH ABSTRACT: We discuss the equations

$$\dot{x} = B - x - \frac{xy}{1 + qx^2}, \quad \dot{y} = A - \frac{xy}{1 + qx^2}. \quad (1)$$

The model was suggested by H. Degn to account for the qualitative features of
the respiratory process in a bacterial culture.

By applying the particular transformations of the parameters, the equations
above are reduced to

$$\begin{aligned} \dot{x} - y - F(x) &= y - \frac{B + (Aq - 1)(B - A)^2}{B - A} + \frac{B}{B - A} e^{-x} \\ &\quad + (B - A)(Bq - 1)e^x - q(B - A)^2 e^{2x}, \\ \dot{y} - g(x) &= (B - A) - (B - A)e^x + q(B - A)^3 e^{2x} - q(B - A)^3 e^{3x}. \quad (2) \end{aligned}$$

The existence of periodic solutions for $-B + (B - A)^2(Bq - 1) - 2q(B - A)^3 > 0$
is obtained and the solutions $x=0$ and $y=0$ of (2) are found globally asymp-
totically stable for

$$(Bq - 1)(B - A) \leq \min \left\{ \frac{B}{B - A}, 2q - (B - A)^2 \right\},$$

or there does not exist any cycle.

9717

CSO: 4009/112

AUTHOR: RONG Sheng [2837 7105]

ORG: Institute of Mechanics, Chinese Academy of Sciences, Beijing

TITLE: "On the Heat Conduction Problems and a Design Principle for Plasma Arc Furnace"

SOURCE: Chongqing YINGYONG SHUXUE HE LIXUE [APPLIED MATHEMATICS AND MECHANICS] in Chinese No 4, Jul 84 pp 511-517

TEXT OF ENGLISH ABSTRACT: A plane heat conduction problem with variable coefficient of heat conductivity $K(T)$ is analyzed with given electric power supplied to the plasma arc. The governing equation for unknown temperature distribution is a nonlinear one with a δ function as its nonhomogeneous term. To make the problem tractable by the method of separation of variables, a set for transformation of the governing equation is introduced. An explicit simple formula is found for the efficiency of the furnace η . η depends linearly on κ_0 , the nondimensional distance between the arc and surface of melted material, as well as on another nondimensional quantity Q , which we described in detail in the paper. This relationship holds for $\kappa_0 < 0.4$, and gives good guidance for the design of the furnace.

AUTHOR: LIN Baisong [2651 2157 2646]

ORG: Central-South Institute of Mining and Metallurgy, Changsha

TITLE: "The Strain Energy Criterion of Mixed-Mode Brittle Fracture"

SOURCE: Chongqing YINGYONG SHUXUE HE LIXUE [APPLIED MATHEMATICS AND MECHANICS] in Chinese No 4, Jul 84 pp 577-588

TEXT OF ENGLISH ABSTRACT: A new criterion for mixed-mode brittle fracture, i.e., the strain energy criterion, which can be stated as $(K_I/K_{IC})^2 + (K_{II}/K_{IIC})^2 + (K_{III}/K_{IIIC})^2 = 1$, is proposed. This criterion is shown to be in good agreement with known experimental data.

An experimental criterion:

$$(K_I/K_{Ic})^m + (K_{II}/K_{IIc})^n = 1 \quad 1 \leq \frac{m}{n} \leq 2$$

is also proposed.

9717

CSO: 4009/115

AUTHOR: DONG Mingde [5516 2494 1795]

ORG: Institute of Theoretical Physics, Chinese Academy of Sciences, Beijing

TITLE: "New Theory for Equations of Non-Fuchsian Type--Representation Theorem of Tree Series Solution (II)"

SOURCE: Chongqing YINGYONG SHUXUE HE LIXUE [APPLIED MATHEMATICS AND MECHANICS] in Chinese No 6, Nov 84 pp 777-792

TEXT OF ENGLISH ABSTRACT: The representation theorem is proved in this paper. The irregular integral is a new type of analytic function, represented by a compound Taylor-Fourier tree series in which each coefficient of the Fourier series is a Taylor series, while the Taylor coefficients are tree series in terms of equation parameters and higher order correction terms to each coefficient having tree structure with inexhaustable proliferation.

The solution obtained proves to be convergent absolutely and uniformly in the region defined by coefficient functions of the original equation, provided the structure parameter is less than unity. Direct substitution shows that our tree series solution satisfies the equation explicitly generation by generation.

When compared with classical theory, our method not only furnished explicit expression of irregular integral, leading to the solution of Poincaré's problem, but also provides the possibility of extending the scope of investigation of analytic theory to equations with various kinds of singularities in a unifying way.

Exact explicit analytic expression for irregular integrals can be obtained by means of the correspondence principle.

It is not difficult to prove the convergence of the tree series solution obtained. Direct substitution shows it satisfies the equation. The tree series is automorphic, which agrees completely with Poincaré's conjecture.

AUTHOR: HUANG Xuncheng [7806 6598 2052]

ORG: Shanghai Institute of Computing Technology, Shanghai

TITLE: "The Bäcklund Transformation and Nonlinear Superposition Formula of Solutions for Liouville's Equation in Higher Dimensions"

SOURCE: Chongqing YINGYONG SHUXUE HE LIXUE [APPLIED MATHEMATICS AND MECHANICS] in Chinese No 6, Nov 84 pp 801-807

TEXT OF ENGLISH ABSTRACT: The Bäcklund transformation derived by Leibbrandt, et al., for Liouville's equation in three spatial dimensions, $\nabla^2 \alpha = \exp \alpha$, $\nabla^2 = \partial_x^2 + \partial_y^2 + \partial_z^2$, can be decomposed into several Bäcklund transformations for the same equation in two spatial dimensions. Moreover, the superposition formula which is derived from this transformation is actually invalid; thus, the discussions based on that formula are incorrect as well. Some results of Liouville's equation in N spatial dimensions are also discussed.

AUTHOR: SHEN Huichuan [3088 1920 1557]

ORG: Department of Earth and Space Sciences, University of Science and Technology of China, Hefei

TITLE: "The Solution of Deflection of Elastic Thin Plate by the Joint Action of Dynamic Lateral Pressure Force in Central Surface and External Field on the Elastic Base"

SOURCE: Chongqing YINGYONG SHUXUE HE LIXUE [APPLIED MATHEMATICS AND MECHANICS] in Chinese No 6, Nov 84 pp 817-827

TEXT OF ENGLISH ABSTRACT: The Euler equation of the deflection of an elastic thin plate is reduced to an equation of Schrödinger form by the principle of quantum electro-dynamics. Then, the general solution of deflection of an elastic thin bending plate by the joint action of dynamic lateral pressure, force in the central surface and external field on the elastic base can be obtained.

AUTHOR: TANG Zemei [0781 3419 4168]

ORG: Institute of Mechanics, Chinese Academy of Sciences, Beijing

TITLE: "One-Dimensional Piston Process in Strong Gravitational Field"

SOURCE: Chongqing YINGYONG SHUXUE HE LIXUE [APPLIED MATHEMATICS AND MECHANICS] in Chinese No 6, Nov 84 pp 829-836

TEXT OF ENGLISH ABSTRACT: The dynamic process driven by a one-dimensional piston in a strong gravitational field was studied on the Cartesian, cylindrical and spherical coordinates. The gas-dynamic equations were numerically solved by the characteristic method. The solution which satisfies the velocity condition at the piston and boundary conditions connecting the flow region and the quiet region is obtained. Especially, the influence of coordinate systems on the field of compressible flow, uniform flow and rarefaction flow region, the shock velocity and the temperature distribution at the piston are analyzed.

9717

CSO: 4009/117

AUTHOR: LI Ao [7812 7663]
LI Zhaozhou [2621 3564 3166]
LEI Zhenghong [7191 2398 1347]

ORG: All of the Burn and Plastic Surgery Society, Medical Science and
Technology Committee, PLA

TITLE: "An Analysis of 48,978 Burn Patients"

SOURCE: Beijing JIEFANGJUN YIXUE ZAZHI [MEDICAL JOURNAL OF CHINESE PEOPLE'S
LIBERATION ARMY] in Chinese No 6, 20 Dec 84 pp 401-407

TEXT OF ENGLISH ABSTRACT: The general data of 48,978 burn cases collected from 16 institutes and burn centers during a period of 22 years (1958-1979) were analyzed. It was found that the highest incidence of burns occurred during the summer and before the age of 30 (78.1 percent), particularly in the age groups of 20-24 and under 5 (22.97 percent and 22.95 percent respectively). Thermal burn was the most common cause (89.57 percent). The ratio between female and male was 1:3. The ratio between cases with and without third degree burns was also 1:3. The burn extent was predominantly under 30 percent TBSA (85.10 percent); cases with burns of more than 70 percent TBSA occupied less than 3 percent of the total. The exposed parts of the body, i.e., head, neck and limbs, were the prevalent areas affected. The mean hospitalization period was 26.9 days. The overall mortality rate was 4.93 percent, and LA₅₀ 75.93 percent ($\hat{Y} = 7.5588 - 0.0337X$). The incidence of shock and sepsis was 10.85 percent and 7.95 percent respectively. It was also found that the mortality rate (in terms of LA₅₀) and incidence of shock and sepsis have lowered remarkably ($p < 0.01$) since 1970. In addition, the correlation between age and LA₅₀ was $\hat{Y} = 57.49 + 1.448X - 0.025X^2$.

AUTHOR: HUANG Meiying [7806 5019 3853]
WANG Dachen [3769 1129 3819]
LIU Yinqiu [0491 5593 4428]
et al.

ORG: All of the Institute of Army Field Surgery, Third Military Medical
College, Chongqing

TITLE: Beijing: JIEFANGJUN YIXUE ZAZHI [MEDICAL JOURNAL OF CHINESE PEOPLE'S
LIBERATION ARMY] in Chinese No 6, 20 Dec 84 pp 411-413

TEXT OF ENGLISH ABSTRACT: Plasma cortisol concentration was investigated in
nine dogs after missile injury induced by a spherical steel bullet 6.35 mm
in diameter, 1.03 g in weight, shot from a distance of 6 m and with impact
velocity of about 1240 m/sec. There were soft tissue wounds in all nine dogs
without damage to large vessels, femur and nerve.

It was observed that the concentration of plasma cortisol increased promptly
after injury and then gradually declined to the level before being shot, and
that the change of plasma cortisol concentration paralleled the severity of
the injury. Therefore, it is suggested that the plasma cortisol concentration
may be a valuable index for estimation of injury severity, with the severity
of injury to the nine dogs being at a minor to moderate degree.

AUTHOR: XU Xiaoshan [6079 1420 3790]
YUAN Benli [5913 2609 0448]
SHEN Juying [3088 5468 5391]
et al.

ORG: All of the Institute of Pharmacology and Toxicology and Instrument
Center, Academy of Military Medical Sciences, Beijing

TITLE: "Pathological Examination of the Gun-shot Shockwave Injury of
Peripheral Nerve"

SOURCE: Beijing JIEFANGJUN YIXUE ZAZHI [MEDICAL JOURNAL OF CHINESE PEOPLE'S
LIBERATION ARMY] in Chinese No 6, 20 Dec 84 pp 414-416

TEXT OF ENGLISH ABSTRACT: Comparative study of two kinds of wound was
examined in the same dog by means of pathomorphological technique. One was
a gun-shot wound (left) and the other was an iron-rod (same diameter as the
missile) penetrating wound (right). These wounds were localized at the
same points near the sciatic nerves of both thighs. In all 31 dogs were
studied in order to illustrate the effect of shockwave contained in gun-shot
wounds to sciatic nerves and other soft tissues. The incidence of sciatic
nerve injury in the gun-shot wounds was 22.6 percent, while that in the
penetrating wound was 0 percent. The size and intensity of lacerated injured
area in the former were larger and more severe than in the latter. The
properties of the gun-shot sciatic nerve injuries were common direct mechanical
peripheral nerve injuries, Wallerian degeneration of the neurofibers, infil-
trated and proliferated reactions of the endoneurium and perineurium. The
shockwave factor in gun-shot injury and the resistance of peripheral nerve
to mechanic force are discussed briefly. The significance of "partial injury
of nerves" in the gun-shot shockwave wounds should be emphasized.

9717
CSO: 4009/123

AUTHOR: YANG Jianshen [2799 0256 6500]
BU Qi [0592 3823]

ORG: Both of Changzhou Municipal Mental Hospital, Jiangsu

TITLE: "Positive Reaction of Serum Anti-DNA Antibody Induced by Phenothiazines in Schizophrenic Patients"

SOURCE: Beijing ZHONGHUA SHENJING JINGSHENKE ZAZHI [CHINESE JOURNAL OF NEUROLOGY AND PSYCHIATRY] in Chinese No 6, 23 Dec 84 pp 333-335

TEXT OF ENGLISH ABSTRACT: The serum anti-DNA antibody of 42 chronic schizophrenic patients was assessed by radio immunoassay method. The patients were divided into three groups: 1) phenothiazine-treated group, 2) drug-free group with cessation of drugs for more than one year, and 3) self-control group. In addition, the normal control group included 67 persons. The results showed that positive reactions to serum anti-DNA antibodies were found in 53.8 percent of the schizophrenic patients after phenothiazine treatment, however, none of the drug-free patients or normal controls revealed positive reactions. This investigation suggests that a positive reaction to serum anti-DNA antibody may give some clues to the prevention of drug-sensitive dermatitis.

9717

CSO: 4009/142

END