

32

JPRS: 3322

27 May 1960

MAIN FILE

RETURN TO MAIN FILE

ON THE DYNAMICS OF A SYSTEM OF CONTROL WHICH INCLUDES INERTIAL

COORDINATE MEASURING INSTRUMENTS

-USSR-

by V. A. Bodner and M. S. Kozlov

DISTRIBUTION STATEMENT

Approved for Public Release
Distribution Unlimited

19990415147

Distributed by:

OFFICE OF TECHNICAL SERVICES
U. S. DEPARTMENT OF COMMERCE
WASHINGTON 25, D. C.

U. S. JOINT PUBLICATIONS RESEARCH SERVICE
205 EAST 42nd STREET, SUITE 300
NEW YORK 17, N. Y.

FOREWORD

This publication was prepared under contract by the UNITED STATES JOINT PUBLICATIONS RESEARCH SERVICE, a federal government organization established to service the translation and research needs of the various government departments.

PTSD

02102 1947

JPRS: 3322

CSO: 3639-D

ON THE DYNAMICS OF A SYSTEM OF CONTROL WHICH INCLUDES INERTIAL
COORDINATE MEASURING INSTRUMENTS

[Following is a translation of an article by V. A. Bodner
and M. S. Kozlov in Izvestiya Akademii Nauk, otdelenie
tekhnicheskikh nauk, Energëtika i Avtomatika (News of the
Academy of Sciences, Department of Technical Sciences,
Power Engineering and Automation), No. 6, 1959, Moscow,
pages 99-107]

Inertial guidance systems can operate under an indicated condition which is characterized by the absence of any dynamic coupling between the motion of the inertial vertical and the motion of the flying vehicle and under a condition of control when there is such a coupling. In the first case, inertial systems are used only as sources of guidance information which serves for general orientation. In the case of a control condition, the information, obtained from the inertial system, is used for the continuous control of the flying vehicle with the aim of retaining it on a fixed trajectory flight or with the aim of arriving at an assigned point of space within a definite time. In addition to this, signals from the output of the inertial system are fed to the input of the control system which acts upon the flying vehicle.

Upon connection of systems to a control circuit, a complex dynamic system is formed with several interacting closed circuits. Analysis of the dynamics of the transient processes in such systems presents great theoretical and practical interest. The task of synthesizing such systems has even more significance.

In this paper, problems of the dynamics of closed control systems are considered which include inertial coordinates, methods of improving the initial display (information of initial deviations to zero) of the inertial systems, the influence of the initial display on the quality of control and certain considerations concerning the selection of parameters. In the capacity of basic disturbances upon the system, gusts of wind, change-over signals, and non-zero initial conditions are employed.

The hook-up circuit of an inertial system to a closed control circuit. Inertial guidance systems are employed in the following control circuits: 1) in a control circuit with lateral deviation of the mass' center from the given trajectory which includes the control circuit of the turn vector velocity in a horizontal plane (Figure 1);

- 2) in a control circuit with deviation of the mass' center from the assigned trajectory of flight in the vertical plane including the turn control circuit of vector velocity in the vertical plane (Figure 2);
 3) in a control circuit with a value of the vector velocity (Figure 2).

As is seen from Figure 1, the control circuit for lateral motion of the flying vehicle, which includes the inertial coordinate measuring instrument, is composed of two closed circuits;

a) the circuit of the inertial system, which includes the first and second integrators with transfer functions k_1/p and k_2/p , feedback with the amplification coefficient g and direct link with the transient function $1/Rp^2$;

b) the control circuit, which includes besides the integrators, the autopilot, control devices, and the flying vehicle. Inasmuch as both circuits have common elements, the static and dynamic errors of the inertial system will be virtually reproduced by the control circuit. As a result, the real trajectory of flight will differ from the given trajectory by the magnitude of errors of the inertial system.

In Figure 2 are shown the control circuit for the inclination angle of the trajectory θ and the control circuit for the magnitude V of vector velocity. One of these circuits is closed via the autopilot and the flying vehicle and the other via the velocity control unit, the motor and the flying vehicle. The projection angle of the trajectory and the magnitude of the vector velocity are obtained in computers to which the signals are fed from the horizontal and vertical channels of the inertial systems. One should note that the conditions of compensation for storage are

$$k_1 k_2 = \frac{1}{R} \quad (1.1)$$

where R - is the distance from the center of the earth to the flying vehicle -- during a variation of flight altitude, it is necessary to introduce corresponding compensation for coefficients k_1 and k_2 .

In the circuits of Figures 1 and 2, the dynamic characteristics of the control system and the flying vehicle are not disclosed. During consideration of the lateral motion of the mass' center of the flying vehicle, it is possible to accept the regulation law of the control system as

$$W(p) = k + \varepsilon p \quad (1.2)$$

but it is possible to describe as the amplifying link with the amplification coefficient k_0 (Figure 3) the dynamics of the flying device together with the dynamics of the final control element of the control system. The range of the first integrator with feedback with coefficient k_3 or with a direct link with coefficient k_4 is fulfilled to obtain a damped inertial system.

Accelerations of a flying vehicle are produced chiefly by the force of gravity acting upon it and by the forces and moments of control mechanisms and by gust of winds. Under the effect of gust of wind, the lateral acceleration z'_a will be

$$\ddot{z} = a_0 \rho \gamma_z \quad (\gamma_z = U_z/V) \quad (1.3)$$

where U_z -- is the velocity of a cross wind, V -- is the flight velocity, and a_0 -- is the constant. The action of gust of wind on the system is shown in the structural diagram (see Figure 3).

2. A control system with an undamped inertial coordinator.

Let us examine the behavior of a lateral motion control system during the utilization of an undamped ($k_3 = k_4 = 0$) of an inertial coordinator. For the composition of equations of the system's motion, we will utilize the structural diagram of Figure 3, assuming $k_3 = k_4 = 0$. We find

$$(p^2 + gk_1k_2) \gamma = (k_1k_2 - 1/R)z \quad (2.1)$$

$$(p^2 + 2d\omega_0 p + \omega_0^2)z = a_0 \rho \gamma_z + \omega_0^2 \varepsilon_0 - (2d\omega_0 p + \omega_0^2)R\gamma \quad (2.2)$$

where

$$2d\omega_0 = k_0 \varepsilon, \quad \omega_0^2 = k_0 k, \quad p = d/dt$$

The first of these equations describes the variation of the projection angle of the inertial vertical, but the second -- is the behavior of the automatically controlled flying vehicle. It is apparent that the inertial vertical and the flying vehicle have a mutual effect upon each other. If one satisfies the condition of compensation (1.1), then the inertial vertical becomes undisturbed and equation (2.1) takes the form

$$(p^2 + \omega^2)\gamma = 0 \quad (\omega^2 = g/R) \quad (2.3)$$

Since equation (2.3) during non-zero initial conditions has a periodic solution

$$\gamma = \gamma_0 \cos \omega t + \frac{\gamma_0'}{\omega} \sin \omega t$$

then it follows from (2.2), that the coordinate of lateral deviation will also effect a periodic motion. In addition, 1.8 km of oscillation amplitude of lateral deviation corresponds to each angular minute of vertical oscillation amplitude. Inasmuch as the initial deviations γ_0 and γ_0' may be significant, then the lateral oscillations of the object in trajectory can achieve impermissibly large magnitudes. Thus, for example, if $\gamma_0 = 15'$, $\gamma_0' = 0$, then the amplitude of lateral deviation will be 27 km.

It should be emphasized that by no selection of parameters k and ε (or for that matter of ω_0 and d) of the control system is it possible to change the reaction of the aircraft to disturbances coming from the inertial system.

Let us examine the reaction of the system to readjustment signals and to gusts of wind. From the structure of equation (2.2), it is apparent that during readjustment of the control system (that is for the assignment of ε_0), the signal will be reproduced with distortions which are peculiar to distortions of a second-order system. In addition to this, inasmuch as the connection coming from the

control system to the inertial system is broken as a consequence of the execution of the compensation condition, then the readjustment signal will not be transmitted to the inertial system.

The disturbances due to gust of wind, either singular or occasional, will not produce significant deviations of the z-coordinate. Thus, for example, when $v_g = 0.1$ (that is, when the velocity of the gust is 10% of the flight velocity) and $\omega_g = 0.2 \text{ sec}^{-1}$, the magnitude of the deviation z will not exceed several meters.

Thus, system disturbances due to the non-zero initial conditions of the inertial vertical exceed disturbances due to gust of wind and readjustment by several degrees. Therefore, information of the initial deviations of the inertial vertical to zero [conditions] is the basic problem of the application of a control system with inertial coordinators. For this, it is possible to apply the precise initial display of the inertial vertical before flight and the introduction of damping into the inertial system so that in the process of flight, the initial disturbances will be reduced to zero. The accurate initial display of the vertical is associated with considerable difficulties, however, it is inevitable in objects with a low flight time ($t_{\text{flight}} \ll 84.4 \text{ min.}$). In objects of which the flight time is comparable with the period of M. Shuler (84.4 min.) damping of the inertial system is employed in addition to the precise initial display.

Until the present, it has been assumed that the compensation condition (1.1) is executed accurately. During inexact execution of this condition, when $k_1 k_2 \neq 1/R = n/R$, where n - is the magnitude ($n \ll 1$), which characterizes the precision of compensation and $z'' = mg$ (m - is the factor of proportionality), equation (2.1) takes the form

$$(\rho^2 + \Omega^2) \gamma = n m \Omega^2 \quad (2.4)$$

From equation (2.4), it is possible to derive that upon the appearance of an acceleration impulse with duration τ , the inertial vertical will oscillate in accordance to the law

$$\gamma \approx m n \Omega \tau \sin \Omega t$$

For $m = 0.5$, $n = 1\%$, $\tau = 300 \text{ sec}$, the amplitude of oscillation will be 5'.

3. A control system with a damped inertial coordinator. If one encompasses the first integrator of the direct ($k_4 \neq 0$) or reverse ($k_3 \neq 0$) connection, then the inertial system will become damped, that is, in its equation of motion is a member which is proportional to the velocity.

First, let us examine a system with feedback for which when $k_3 \neq 0$ we obtain (we assume that the condition of compensation (1.1) is fulfilled).

$$(\rho^2 + 2D\Omega\rho + \Omega^2)\gamma = -b\rho z \quad (\Omega^2 = g/R; 2D\Omega = k_4 k_3; b = \frac{k_1 k_2}{R}) \quad (3.1)$$

$$(\rho^2 + 2d\omega_0\rho + \omega_0^2)z = a_0\rho\gamma + \omega_0^2 \varepsilon_0 - (2d\omega_0\rho + \omega_0^2)R\gamma \quad (3.2)$$

$$(\omega_0^2 = k_0 k; 2d\omega_0 = k_0 \varepsilon).$$

From equation (3.1) it is apparent that within the scope of the first integrator with feedback, the system will become damped and simultaneous with this, disturbed. In addition to this, the larger the damping factor k_3 , the larger the term in the right hand portion of equation (3.1) and consequently, the more the system is disturbed. For an evaluation of the magnitude of the system's disturbance, let us assume that it operates in the indicated condition, that is, the system of control does not function. In this case, during a cross wind, the flying vehicle will agree with velocity z . Having taken, for example, the rate of pitch $z' = 30$ m/sec, we obtain from (3.1) ($D = 1$, $\Omega = 1.23 \times 10^{-3}$ 1/sec)

$$\gamma^0 = \frac{2D\Omega}{R\Omega^2} z' = -\frac{2D\Omega}{9} z' = -0.4^\circ$$

Consequently, during a strong cross wind, a damped inertial system, operating in the indicated condition, has impermissible errors.

Upon connection of an inertial system to the control circuit, the effect of pitch will compensate for the wind by yawing of the flying vehicle. Therefore, the behavior of the inertial system and the flying vehicle will be different. For evaluation of this behavior, let us solve equations (3.1) and (3.2) with reference to z and γ . We find

$$[(p^2 + \Omega^2)(p^2 + 2d\omega_0 p + \omega_0^2) + 2D\Omega p^3] \gamma = -b p \gamma \quad (3.3)$$

$$[(p^2 + \Omega^2)(p^2 + 2d\omega_0 p + \omega_0^2) + 2D\Omega p^3] z = (p^2 + 2D\Omega p + \Omega^2) \gamma \quad (3.4)$$

where

$$\gamma = \alpha_0 p z + \omega_0^2 \xi_0$$

From equation (3.3), it follows that inasmuch as magnitude γ is multiplied by the differential operator p , then constant values of readjustment signal and gust of wind will not be professed in the accuracy of the vertical. Behavior of the vertical will be determined only by the variable term of the magnitudes ξ_0 and γ_2 .

Now we will show that the considered closed control system, described by equation (3.4), is unstable. Having applied the criterion of Hurvitz, we will obtain

$$\Delta = 4D\omega_0 \Omega^3 [d(\Omega^2 - \omega_0^2) - D\Omega \omega_0] < 0 \quad (3.5)$$

since $\Omega \ll \omega_0$. Thus, damping introduced into the inertial system by means of the internal coupling (feedback) appears only in the indicated condition. In the control condition, it disappears and the system becomes unstable.

Let us show, that a system which remains unstable, is found close to the boundary of stability. For this, let us note that the polynomial in the left-hand portion of equations (3.3) and (3.4) with a large degree of accuracy is broken down into two co-factors of the type

$$(p^2 - 2D_1 \Omega p + \Omega^2)(p^2 + 2d\omega_0 p + \omega_0^2) \quad (D_1 \approx d \frac{\Omega^2}{\omega_0^2}) \quad (3.6)$$

If one takes $\Omega/\omega_0 = 0.01$, then the growth coefficient of oscillations when $d = 1$ will be $D_1 = 10^{-4}$, that is, an increase of the amplitude of oscillations during the period (during 84.4 min) will be several fractions of a percent.

Disregarding this increase of oscillation magnitude ($D_1 = 0$) and assuming $d = 1$, one can write the expression for the solution of equation (3.4) during a disturbance by gusts of wind and zero initial conditions

$$z = z_0 \left[\frac{A}{\Omega} (1 - \cos \Omega t) + \frac{B}{\Omega} \sin \Omega t + \left(D' - \frac{C}{\omega_0} \right) t e^{-\omega_0 t} + \frac{C}{\omega_0^2} (1 - e^{-\omega_0 t}) \right] \quad (3.7)$$

where

$$A = 2\Omega \frac{\omega_0^2 (\omega_0 - \Omega)^2}{(\omega_0^2 + \Omega^2)^2}, \quad B = \frac{2\Omega^2}{\omega_0^2 + \Omega^2}, \quad C = -2\Omega \omega_0^2 \frac{(\omega_0 - \Omega)^2}{(\omega_0^2 + \Omega^2)^2}, \quad D' = \frac{\omega_0^2 - \Omega^2}{\omega_0^2 + \Omega^2}$$

From the examination of expression (3.7), it is apparent that the reaction of the system to gust of wind consists of two motions: slow sustaining [motion] with Shuler's period and rapid damping motion. In addition to this, the maximum deviation of the damping portion of the motion and the amplitude of the oscillation of the sustaining portion does not exceed several meters during possible gust and optimum parameters of the control system.

Thus, a closed control system, which includes a damped inertial coordinator, will conduct itself with regard to gusts of wind in practically the same manner as a system with an undamped inertial coordinator, successfully counteracting the effect of wind. The difference consists only in the appearance under the effect of wind of low frequency oscillations of the vertical and flying vehicle of very small amplitude. Consequently, external disturbances due to gust of wind, which are fundamental for a flying vehicle, are not determinants for the system. The accuracy of a control system is almost totally determined by the instrumental errors of the inertial system.

Let us examine the behavior of a control system under the effect of a single readjustment signal ϵ_p . Assuming the initial conditions to be zero and $v_z = 0$, let us derive the expression for the reaction of the system to a readjustment signal as the solution of equation (3.4)

$$z = \omega_0^2 \epsilon_p \left[\frac{A_1}{\Omega^2} (1 - \cos \Omega t) + \frac{B_1}{\Omega} \sin \Omega t + \left(D_1' - \frac{C_1}{\omega_0} \right) t e^{-\omega_0 t} + \frac{C_1}{\omega_0^2} (1 - e^{-\omega_0 t}) \right] \quad (3.8)$$

where

$$A_1 = \frac{4\omega_0 \Omega^2}{(\omega_0^2 + \Omega^2)^2}, \quad B_1 = -D_1' = \frac{2\Omega(\omega_0^2 - \Omega^2)}{(\omega_0^2 + \Omega^2)^2}, \quad C_1 = 1 - \frac{4 - 2\omega_0^2}{(\omega_0^2 + \Omega^2)^2}$$

Disregarding in (3.8) Ω in comparison with ω_0^2 ($\Omega/\omega_0 \approx 0.01$), we will obtain

$$z = \epsilon_0 [1 + 2 \sin \Omega t - (1 + \omega_0 t) e^{-\omega_0 t}] \quad (3.9)$$

Hence, it follows that by feeding of the signal to the input of a control system with damped inertial coordinator, it is impossible to readjust the flight to a new parallel trajectory. At first, the flying vehicle, for the time $4/\omega_y$ sec, rapidly emerges on the new assigned trajectory, but then it begins to perform [in accordance] to its sustaining oscillations with an amplitude, which is equal to the doubled readjustment signals, and with a frequency Ω of the inertial system. If one does not make the above indicated approximations, then we will find that the flying vehicle will execute the very slow divergent oscillations.

Similarly, one can find the reaction of the system to non-zero initial conditions. Assuming $\dot{\epsilon}_\phi = 0$, $\gamma_\phi = 0$, and ignoring the rapidly damping terms, and also ignoring Ω^2 in comparison with ω_y^2 , we will find that

$$z = R_1 \epsilon_0 (1 - \cos \Omega t) \quad (3.10)$$

In addition to this, it is assumed that there is only the initial deviation γ_0 from the inertial vertical to the spatial vertical. It is apparent that the system does not dispose of the initial deviations but will oscillate with amplitude $R_1 \epsilon_0$, that is, it will conduct itself similar to the system with an undamped inertial coordinator.

Let us now examine a control system with an inertial coordinator in which damping is introduced by means of the envelopment of the first integrator by direct connection with the transient factor k_4 (see Figure 3). In this case, the equation of the inertial system in place of (3.1) takes the form

$$(\rho^2 + 2D\Omega\rho + \Omega^2)\gamma = b\rho^3 z \quad (\Omega^2 = g/R, 2D\Omega = gk_2 k_4, b = k_2 k_4) \quad (3.11)$$

Equation (3.2) remains unchanged.

Solving jointly equations (3.2) and (3.11), we will find

$$[(\rho^2 + \Omega^2)(\rho^2 + 2d_1\omega_1\rho + \omega_1^2) + 2D_1\Omega\rho^3]\gamma = b\rho^3 y \quad (3.12)$$

$$[(\rho^2 + \Omega^2)(\rho^2 + 2d_1\omega_1\rho + \omega_1^2) + 2D_1\Omega\rho^3]z = (\rho^2 + 2D\Omega\rho + \Omega^2)\gamma \quad (3.13)$$

where

$$2d_1\omega_1 = 2\omega_0 \frac{d + D \frac{\omega_0}{\Omega}}{1 + 4dD \frac{\omega_0}{\Omega}}, \quad \omega_1^2 = \frac{\omega_0^2}{1 + 4dD \frac{\omega_0}{\Omega}}$$

$$D_1 = \frac{D}{1 + 4dD \frac{\omega_0}{\Omega}}, \quad y = \frac{2_0 p \gamma_0 + \omega_0^2 \epsilon_0}{1 + 4dD \frac{\omega_0}{\Omega}}$$

Comparing equations (3.3) and (3.4) for the control system with an initial coordinator, with the damped [one] by means of feedback, with equations (3.12) and (3.13) for a system with direct coupling, we come to the conclusion that with regard to the z-coordinate, both systems conduct themselves similarly. In other words, independent of the type of damping coupling in the inertial coordinator, the behavior of the automatically controlled flying vehicle in a flight trajectory will be the same in both cases. Therefore, the above made analysis of the reaction of the flying vehicle to various disturbances also remains correct in the considered case. Regarding the reactions of the inertial vertical to readjustment disturbances and gust of wind [we find that] it will be different for both examined systems. In the system with feedback envelopment of the first integrator, the vertical is at one time static with regard to readjustment and gusts of wind and then as in a system with envelopment of the first integrator by direct coupling, the vertical is three times as static with regard to these disturbances.

The performed analysis indicates that upon rigid tying of the control object to an assigned trajectory, it is impossible to achieve introduction of damping into the system for elimination of the initial deviations (errors) because of the single couplings inside the inertial system. This is explained by the fact that damping for the inertial system in the indicated condition is introduced at the expense of effects on the system of external disturbances which are proportional to the derivative of the lateral deviations. In the case of connection of the damped inertial system to a closed control circuit, these disturbances will be quickly compensated at the expense of forces, which are created by the control system and as a result, the reason is eliminated which caused damping of the inertial system.

4. A control system with an inertial coordinator for flexible tying to the assigned trajectory. Up to now, a closed control system has been considered in which rigid tying to the assigned trajectory has been provided. Such a method of guidance of an object is not always necessary. Most frequently of all is required control which provides an outlet to the assigned point in space. Let us consider one of the possible variants of such a guidance method.

From expression (3.5), it is apparent that an increase of damping coefficient D of the inertial system will result in an increase of instability of the control system. In this case, the control system, as a result of the violation of the compensation condition oscillates the inertial system. For elimination of the effect of the control system on the inertial system, it is expedient at the display time of the vertical to reject the rigid tying of the objects to the assigned trajectory; in this case, the inertial vertical will execute damping motions. For proof of this, let us turn to Figure 4 in which is shown the structural diagram of the system.

Equations of the motion of the inertial vertical and the control circuit can be represented in operational form

$$(\rho^3 + A_1 \Omega_1 \rho^2 + A_2 \Omega_1^2 \rho + \Omega_1^3) \gamma = (\rho + A_1 \Omega_1) \rho^2 \gamma_0 - b \gamma \quad (4.1)$$

$$(\rho^3 + A_1 \Omega_1 \rho^2 + A_2 \Omega_1^2 \rho + \Omega_1^3) \rho z = (\rho^2 + 2D\Omega \rho + \Omega^2) \gamma - 2d\omega_0 R (\rho + 2D\Omega) \rho^2 \gamma_0 \quad (4.2)$$

where

$$A_1 \Omega_1 = 2d\omega_0 + 2D\Omega, \quad A_2 \Omega_1^2 = \Omega^2, \quad \Omega_1^3 = 2d\omega_0 \Omega^2$$

$$\gamma = \alpha_0 \rho \gamma_2, \quad b = \frac{k_1 k_3}{R}$$

$$2d\omega_0 = \varepsilon k_1 k_0, \quad 2D\Omega = k_1 k_3, \quad \Omega^2 = g k_1 k_2$$

γ_0 -- is the initial value of the deviation angle of the vertical. It is easy to see that the considered system is stable. In fact,

$$\Delta_2 = A_1 A_2 \Omega_1^3 - \Omega_1^3 = 2D\Omega^3 > 0 \quad (4.3)$$

Consequently, the closed system is stable during damping in the inertial vertical and in addition, the stability reserve does not depend on the amplification coefficient of the control system. Together with this, damping of the inertial vertical does not disappear as happened above.

From the structure of the coefficients of the left-hand portions of equations (4.1) and (4.2), it is apparent that one can establish a definite transient process in a closed system. For this, in accordance to known optimum criteria, one should determine the transient number k_0 of the control system and the attenuation factor k_3 of the vertical.

The physical significance of the behavior of a closed control system during feeding to the input does not consist of a deviation but of the velocity in the following [explanation]. If at the initial moment of flight, the indicated vertical, assigned by the inertial system, does not coincide with the spatial vertical, then in the inertial system there arise oscillations which will be transmitted to the control system. In addition, the control system will produce acceleration of such a phase during which attenuation of the oscillations of the vertical are rendered. Inasmuch as motions of the vertical are damping, then with the lapse of time which is approximately equal to a quarter of the period, the indicated vertical will be found near the true vertical.

The most important quality of the examined system is that in the process of eliminating the initial deviation of the inertial vertical, drift compensation of the gyroscope is provided. This is achieved at the expense of the creation of a signal by the first integrator which compensates the disturbing moment M_d , which acts

along the correction axis of a gyroscope and effects its servicing. In the considered case, deviation of the inertial vertical is static with regard to disturbing moment M_d

$$\frac{Y}{M_d} = \frac{k_{2,1}(\rho + A_1 \Omega_1)}{\rho^3 + A_1 \Omega_1 \rho^2 + A_2 \Omega_1^2 \rho + \Omega_1^3}$$

One must note that the elimination process of the initial deviation of the inertial vertical from the true vertical is accompanied with an accumulation of the deviation of the flying vehicle as follows from the transient function

$$\frac{z}{M_d} = \frac{\Omega^2}{\rho^3 + A_1 \Omega_1 \rho^2 + A_2 \Omega_1^2 \rho + \Omega_1^3}$$

It is possible to conceive a possible way of utilizing the proposed method of damping of the inertial vertical in the following form. From the very start of the flight, the control system is connected in a stabilization rate condition during which the initial deviations of the vertical are corrected to permissible value. This elimination occurs at this expense -- that the flying vehicle descends from the primary trajectory to the side of the indicated vertical deviation. When the indicated vertical approximates the true spatial vertical, the flying vehicle is apart from the primary trajectory by the value R .

At the instant of approximation of the indicated vertical to the spatial vertical, which comes after 25 - 30 minutes, it is necessary to determine by means of a source of external information [1] the magnitude $R \gamma_{\phi}$, to introduce this value z into the measuring system, to switch over the control system from stabilization rate condition to the stabilization lateral deviation condition of the new direction, and to switch off the damping circuit of the vertical (link k_2 in Figure 4).

The theory expounded in this article is applicable to systems the operation time of which is comparable with the period of the inertial system.

Conclusions. 1. Upon connection of an undamped inertial system to a closed control circuit, retention of the object on the assigned flight trajectory is provided. However, upon imprecise execution of the compensation conditions and during non-zero initial conditions, the inertial system will perform damping motion which will result in inaccurate guidance of the object and in inaccurate exit to the assigned point.

2. For any method of the introduction of damping into an inertial system by way of internal couplings, the compensation conditions are violated and the system will become disturbed. Connection of such an inertial system to a closed control circuit will result in the disappearance of damping and the entire control circuit will become unstable. Although the growth of oscillations in such a system is very slow and during the flight time the departure of the object

from the assigned trajectory may be insignificant, nevertheless, the impossibility of readjustment of the system for flight along a parallel trajectory limits the application possibilities of the system.

3. The best results within the concept of the dynamics of the transient process in a closed circuit are obtained in that case when during the display time, the system is switched over from stabilization of lateral deviations to stabilization of lateral velocities. After completion of the vertical's display, one should again switch over to system to a condition of lateral deviation stabilization, having disconnected at the same time the damping.

Submitted June 10, 1959

BIBLIOGRAPHY

1. Bodner, V. A., Seleznev, V. P., Ovcharov, V. E. Concerning the theory of inertial damping systems, with an arbitrary period which are] invariant as regards the maneuverability of the object. [K teorii inertsiyal'nykh dempfirovannykh sistem s proizvol'nym periodom, invariantnykh po otnosheniyu k manevrirovaniyu ob'ekta.] Record of the Academy of Sciences, Department of Technical Sciences, Power Engineering and Automation, No. 3, 1959.
2. Wrigley, W., Woodbury, R. B., Hovorka, J. Inertial Guidance. N. Y., 1957.

5600

FIGURES

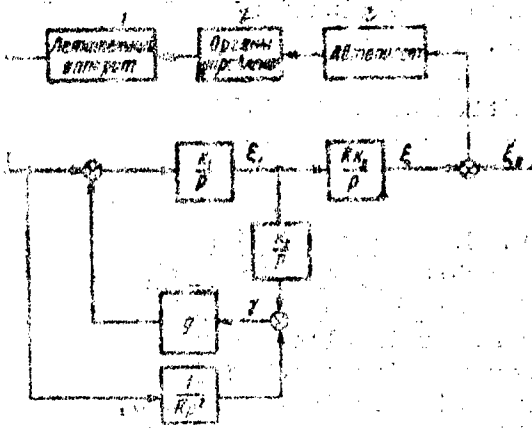

Figure 1.

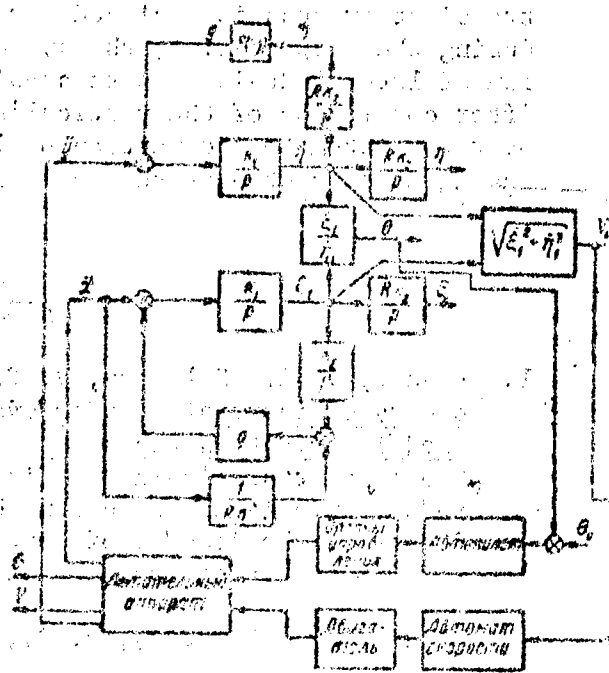

Figure 2.

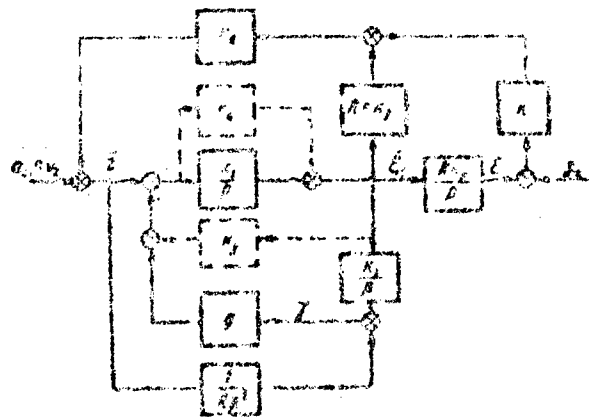

Figure 3.

