

254079

JPRS-UEN-86-009

15 APRIL 1986

USSR Report

ENERGY

19990428 103

DTIC QUALITY INSPECTED 2

DISTRIBUTION STATEMENT A
Approved for Public Release
Distribution Unlimited

FBIS

FOREIGN BROADCAST INFORMATION SERVICE

6
55
A04

NOTE

JPRS publications contain information primarily from foreign newspapers, periodicals and books, but also from news agency transmissions and broadcasts. Materials from foreign-language sources are translated; those from English-language sources are transcribed or reprinted, with the original phrasing and other characteristics retained.

Headlines, editorial reports, and material enclosed in brackets [] are supplied by JPRS. Processing indicators such as [Text] or [Excerpt] in the first line of each item, or following the last line of a brief, indicate how the original information was processed. Where no processing indicator is given, the information was summarized or extracted.

Unfamiliar names rendered phonetically or transliterated are enclosed in parentheses. Words or names preceded by a question mark and enclosed in parentheses were not clear in the original but have been supplied as appropriate in context. Other unattributed parenthetical notes within the body of an item originate with the source. Times within items are as given by source.

The contents of this publication in no way represent the policies, views or attitudes of the U.S. Government.

PROCUREMENT OF PUBLICATIONS

JPRS publications may be ordered from the National Technical Information Service (NTIS), Springfield, Virginia 22161. In ordering, it is recommended that the JPRS number, title, date and author, if applicable, of publication be cited.

Current JPRS publications are announced in Government Reports Announcements issued semimonthly by the NTIS, and are listed in the Monthly Catalog of U.S. Government Publications issued by the Superintendent of Documents, U.S. Government Printing Office, Washington, D.C. 20402.

Correspondence pertaining to matters other than procurement may be addressed to Joint Publications Research Service, 1000 North Glebe Road, Arlington, Virginia 22201.

Soviet books and journal articles displaying a copyright notice are reproduced and sold by NTIS with permission of the copyright agency of the Soviet Union. Permission for further reproduction must be obtained from copyright owner.

15 April 1986

USSR REPORT
ENERGY

CONTENTS

FUELS

OIL AND GAS

Implosion Suggested as Effective Method of Bottom-Hole Treatment (A. Popov; NEFTYANIK, No 1, Jan 86).....	1
Caspian Sea Oil, Gas Workers' 1986 Socialist Obligations (VYSHKA, 29 Dec 85).....	7
Azerbaijan Oil, Gas Industry Development (M.A. Mamedov; AZERBAYDZHANSKOYE NEFTYANOYE KHOZYAYSTVO, No 12, Dec 85).....	9
Oil, Gas Drilling Indicators in Azerbaijan (VYSHKA, various dates).....	14
Extraction, January-July	14
Extraction, January-August	15
Extraction, January-September	16
Extraction, January-October	17
Extraction, January-November	18
Extraction, January-December	19
Drilling, January-July	20
Drilling, January-August	21
Drilling, January-September	22
Drilling, January-October	23
Drilling, January-November	24
Drilling, January-December	25
Assimilating Oil Resources of Western Siberia (F.K. Salmanov, et. al.; GEOLOGIYA NEFTI I GAZA, No 10, Oct 85).....	26

Scientific, Technological Progress in Oil, Gas Construction (STROITELSTVO TRUBOPROVODOV, No 10, Oct 85).....	27
ELECTRIC POWER	
NUCLEAR POWER	
Plans for Georgian Nuclear Powerplant (KOMUNISTI, 27 Nov 85).....	30
ENERGY CONSERVATION	
Natural Gas Consumption, Safety in Armenian SSR (B. Beglaryan; KOMMUNIST, 14 Nov 85).....	31
Leningrad Needs More Challenging Energy Conservation Program (P. Sivko; LENINGRADSKAYA PRAVDA, 12 Jan 86).....	34
Survey of Fuel, Power Consumption Problems (S. Yatrov, V. Chebotarev; EKONOMICHESKAYA GAZETA, No 6, Feb 86).....	37
Mild Winter, New Power Plants Help Satisfy Demand (A. Nikolayev; EKONOMICHESKAYA GAZETA, No 6, Feb 86).....	43
Briefs	
Moscow Natural Gas Consumption	45
Hidden Fuel Costs	45
GENERAL	
Leading Academicians Discuss Soviet Energy Developments, Trends (PRAVDA, 24 Dec 85).....	46
Briefs	
Rural Power Organization	50
Estonian Power System	50
Azerbaijan Power System	50

OIL AND GAS

IMPLOSION SUGGESTED AS EFFECTIVE METHOD OF BOTTOM-HOLE TREATMENT

Moscow NEFTYANIK in Russian No 1, Jan 86 pp 8-9

[Article by A. Popov, PechorNIPIneft [Pechora Scientific Research and Designing Institute for Petroleum]: "On the Way to Acceleration, From the 8th Plenum of the Trade Unions' Central Committee"]

[Text] Because the permeability of bottom-hole formation zones decreases in the course of drilling, completion and operation of wells owing to clay encroachment, adsorption of asphalt and tar compounds and other processes occurring on the surface of filtration channels, artificial low-permeability barriers, stagnant pockets and pillars of unrecovered oil form. Not only the productivity of individual wells but also the oil yield from the field as a whole decreases in this connection. Numerous methods of different kinds for treating the bottom-hole formation zone of wells have been developed in order to reduce these negative phenomena. Each year around 13,000 well processing operations are carried out in the sector's fields, owing to which 2 million more tons of oil can be extracted. However, despite the results that have been attained, for a number of reasons the successfulness of this work continues to be low (50 percent for the sector on the average), while effectiveness remains unsatisfactory. Some forms of treatment are not always effective, while others are expensive, they are difficult to carry out, and they are not always possible. Sometimes oilmen base their choice of the method not on the concrete conditions of the oil field but rather on the basis of organizational possibilities--namely, the extent the method has been utilized in the given region, its laboriousness, the complexity of the process, presence of equipment and so on. As a consequence the potentials of some methods are underutilized, while other methods are found to be ineffective. Oilmen experience special difficulties in well completion in northern fields characterized by poor reservoir properties and productive strata buried at significant depths.

Under these conditions the implosion method is rather effective. The device used with this method, called a pressure hydrogenerator, consists (Figure 1) of a housing 8 (the implosion chamber) containing a piston 10 playing the role of a false locking device; a diaphragm 5 held down by a nipple 4; a bell nipple 3 with ports providing communication between well pipes and the casing string-borehole annulus on one hand and the chamber on the other after the diaphragm ruptures; trap 12 with pressure concentrators 13. The piston can be separated from the housing with a small force ($\Delta P=0.01$ MPa) and operate as a reflux valve.

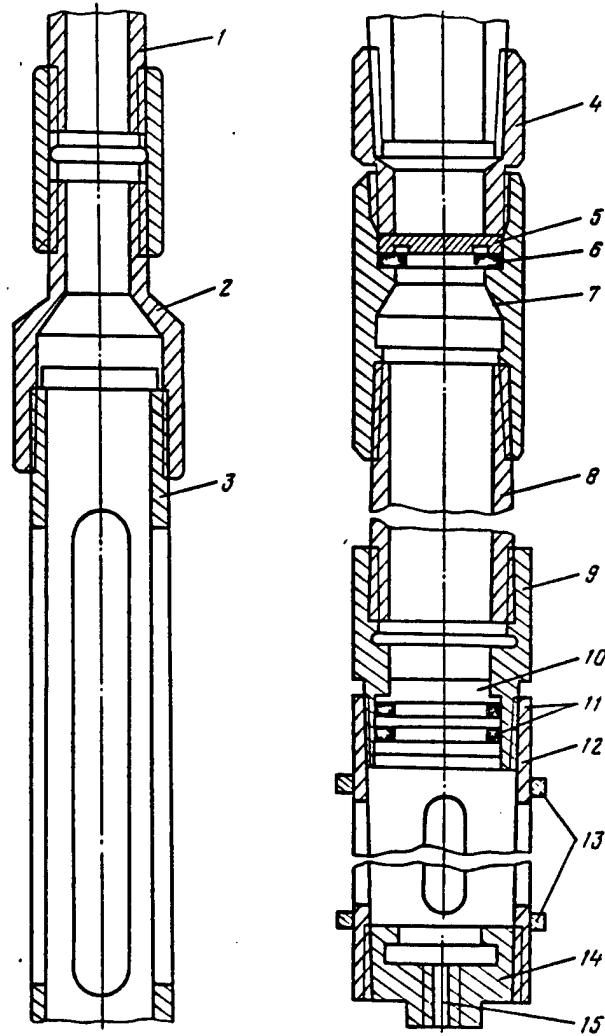

Figure 1. Pressure Hydrogenerator: 1--tubing; 2--sub; 3--bell nipple; 4--nipple; 5--plug-diaphragm; 6--seal; 7--special coupling; 8--housing (implosion chamber); 9--adapter; 10--piston; 11--sealing rings; 12--trap; 13--pressure concentrators; 14--nut with safety ring; 15--crusher attachment hole

The device is lowered into the well attached to the tubing in such a way that its lower section stops level with the reservoir. The annular valve is closed, working agent (aqueous surfactant solution, oil, hydrocarbon solvent or acid solution) is pumped into the well, pressure is raised at the wellhead to 10-20 MPa, and the diaphragm is ruptured. After this, well fluid fills the implosion chamber at a high rate and forces the piston toward the well bottom--into the trap, creating first an instantaneous pressure drop in the bottom-hole formation zone, and then a hydraulic shock with pressure exceeding rock pressure.

The pressure drop promotes removal of clay particles, paraffin and asphalt-tar deposits and other contaminants from the bottom-hole formation zone, while the hydraulic shock creates conditions for expansion of natural cracks or formation of new residual cracks in the bottom-hole formation zone, which, in view of the irreversibility of the rock deformation processes, do not close up completely in response to rock pressure and remain open without the need for pumping reinforcing materials into them.

Thus the method basically entails improving the filtration characteristics of the bottom-hole formation zone, and an increase in well productivity is achieved through the use of the energy of the hydraulic shock created by the falling column of well fluid.

After the diaphragm is ruptured, which is determined from the abrupt pressure change (decrease) at the wellhead or from the sound created by its rupture, the well is subjected to reverse flushing with a quantity of 1 percent aqueous ML-72 solution equal to 1.2 times the tubing volume, and the bed intake rate is determined with the annular valves closed. When the bed intake rate is sufficient ($8 \text{ m}^3/\text{hr}$), first 15 percent hydrochloric acid solution and then acid clay drilling mud (up to 5-10 percent HF plus 10-15 HCl) are forced into oil and injection wells tapping dense low-permeability terrigenous reservoirs, and hydrochloric acid (acid foam) solution is forced into wells with carbonate reservoirs. This sequence of pumping in the drilling mud is followed in order to prevent settling of poorly filtering insoluble calcium and magnesium fluoride precipitants.

Residual acids in the tubing are forced into the bed with aqueous surfactant solution or oil. Then the well is left idle for 1-2 hours to allow the acid to react with the reservoir rock, after which the bed is drained or additional oil or aqueous surfactant solution is pumped into the bed at a rate of 10 m^3 per meter of bed thickness in order to remove reaction products from the bottom-hole formation zone.

If free flow is discovered after the development well is subjected to such processing, the generator is left in the well until the next underground repairs are carried out, and the well is placed into operation without raising the pressure hydrogenerator to the surface. If positive results are obtained after treating the bottom-hole formation zones of injection wells, water is pumped into the latter without raising the generator to the surface.

In the absence of signs of free flow, the tubing string is raised to the surface together with the pressure hydrogenerator, and the well is set up for submerged pump exploitation.

The method possesses the following advantages:

Owing to the position of the membrane in the upper part of the device and presence of a nipple with ports, the entire mass of liquid present in the well (in the tubing and in the annulus) takes part in creating the hydraulic shock after the membrane is ruptured, which increases the force of the shock;

owing to the fact that there is a piston in the lower part of the implosion chamber that is separated easily from the generator housing by the action of the descending flow of working fluid, conditions for appearance, in the zone of the bed being treated, of a direct hydraulic shock promoting formation of a network of residual cracks in the bottom-hole formation zone not requiring reinforcement with sand, as is required in hydraulic fracturing of a formation, is insured;

a possibility for integrated, multifactor treatment of the bottom-hole formation zone becomes possible: Preliminary treatment with hydrocarbon solvents in order to dissolve paraffin-tar deposits may be followed by implosion to remove contaminants from the bottom-hole formation zone and to create cracks, and subsequent pumping of acid solutions or other intensifying agents into the bed. Moreover all of this work can be done without carrying out additional raising and lowering operations with the tubing string, which simplifies the well treatment process;

after the well is subjected to treatment, it can be placed into operation immediately without having to raise the generator to the surface;

because the length of the implosion chamber, which consists of tubing, can be changed, when the chamber is oriented in a particular way within the interval of the bed subjected to treatment, the device makes use of the controllable pressure drop method possible;

owing to presence of pressure concentrators in the trap, the device can be used for selective influence on beds without having to use packing equipment; the method is simple and easy to carry out. It requires one Azinmash-30A pumping unit and one hoist, rather than the five to eight 4AN-700 pumping units, the sand mixing unit and the manifold block required with hydraulic fracturing;

the method can be used in the conditions afforded by any oil fields and wells irrespective of the type of reservoir and the depth and purpose of the well.

The most favorable objects for successful conduct of the process are wells in their initial stage of exploitation characterized by high reservoir pressures but low productivity. The best results are achieved with wells characterized by low productivity located in "oxidized" zones of deposits or near wells characterized by high productivity, and with wells tapping carbonate and fractured reservoirs, when the filtration surface and the bottom-hole zone are clogged in the course of drilling, completion or exploitation. It would be desirable for the well to have a sump 15-50 m deep. The thickness of the bed must be not less than 2 m, and its intake rate must be not more than 200 m³/day.

Pressure hydrogenerators are suggested for use chiefly in wells in which all other known methods previously assimilated in the given region have been found to be ineffective, although in principle pressure hydrogenerators may be used beneficially in any low-yield wells.

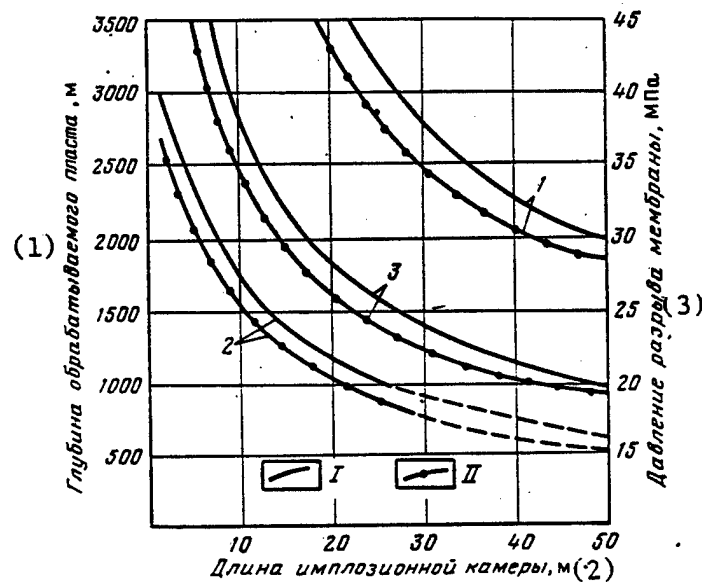

Figure 2. Nomogram for Determining the Length of the Generator's Implosion Chamber Insuring Creation, in the Reservoir Zone to be Treated, of a Hydraulic Shock with a Pressure Equal to 100 Percent (1), 200 Percent (2) and 150 Percent (3) of the Rock Pressure When Using the Following as the Drive Fluid: I--water, with a density of 1.000 kg/m³; II--oil, with a density of 855 kg/m³

Key:

1. Depth of bed to be treated, m
2. Length of implosion chamber, m
3. Diaphragm rupture pressure, MPa

Before the generator is assembled, its threaded connections and rubbing surfaces must be inspected, cleaned and lubricated. In all cases the implosion chamber must be tested for external tightness by a pressure equal to the anticipated hydrostatic pressure. If it is found that fluid enters the chamber, certain units or parts must be replaced and the connections and rubber seals must be additionally tightened and lubricated, since implosion would not occur (the diaphragm would not rupture) when fluid leaks into the generator chamber. The length of the implosion chamber must be selected using a nomogram (Figure 2).

If the well is not filled with fluid, then in order to keep the piston from jerking out of position while the tubing string is being mounted on the elevator, the generator must be lowered to its static level at a rate of not more than 0.5 m/sec. After this, it may be lowered down into the interval of the bed to be treated at a rate of 1 m/sec.

The experience of treating wells using the pressure hydrogenerator at oil fields of the Komineft Association demonstrated its effectiveness. Of 25 treatment operations, 13 were successful. The yields of some of the producing wells (No 193, 194, 920) of the Usinskoye oil field, which are characterized by exceptionally low reservoir permeability ((50-100)·10⁻¹⁵ m²), increased by several orders of magnitude (from 1-6 to 32-77 tons/day). The intake rate of injection wells of the Usinskoye (No 795) and Vozeykoye (No 604)

fields increased correspondingly from 170 to 480 and from 130 to 430 m³/day. The duration of the effect was 6-24 months. The relative economic impact in 1984 was 23,200 rubles per well.

The pressure hydrogenerator underwent departmental acceptance trials and was recommended by the Ministry of Petroleum Industry for introduction at the sector's oil fields. The "Instructions on Treating Wells Using GGD-89-350 Pressure Hydrogenerators" (RD 39-1-1040-84) were placed into effect.

COPYRIGHT: Izdatelstvo "Nedra" "Neftyanik", 1986

11004

CSO: 1822/181

OIL AND GAS

CASPIAN SEA OIL, GAS WORKERS' 1986 SOCIALIST OBLIGATIONS

Baku VYSHKA in Russian 29 Dec 85 p 1

[Article: "We Will Give the Country More Oil and Gas"]

[Excerpts] The 1986 Socialist Obligations of the Collective of the Labor Red Banner Production Association for Oil and Gas Extraction imeni XXII Syezda KPSS VPO Kasporneftegazprom.

On the basis of widespread introduction of scientific-technical advances and improving the technology of working deposits and use of efficient techniques of recovery extract 5,000 tons of petroleum above the plan, 1,000 tons by the opening of the 27th CPSU Congress. Overfulfill the assignment for growth in labor productivity by one percent through use of progressive methods of labor, automation of production processes, mechanization of labor-intensive jobs, strengthening labor and production discipline, and increasing the accountability of each member of the collective for the assigned work.

Ensure an increase in the pace of construction at the deep Deposit imeni 28 Aprelya, introducing 14 new high-yielding wells into operation there. Improve work on the existing stock of wells, achieve an increase in the period of well operation between scheduled servicing times, and increase the efficiency of steps being taken to intensify petroleum extraction. Launch 70 new wells in operation, carry out more than 1,000 engineering geological measures, and ensure that at least 90 percent of the petroleum delivered is in the first quality category.

By improving the organization of drilling work, rigorous observance of technological regimes in well drilling, use of progressive types of rock-cutting tools and washes, and broad dissemination of the know-how of leading brigades drill 500 meters of rock beyond the plan and reduce the prime cost of drilling per meter by 0.5 percent.

Through economical, prudent treatment of oilfield equipment and machinery save 1.5 million kilowatt-hours of electricity and 400 tons of standard fuel. Work 3 days with conserved material and fuel-energy resources.

Develop the creative activism of workers and engineering-technical personnel by every means, and achieve an economic impact of at least 300,000 rubles from

introduction of inventions and efficiency proposals into production. Raise the level of professional skills of workers, engineers, and technicians, involve 1,100 persons in all types of technical and economic study, and raise the qualifications and teach related occupations to 150 persons.

Improve the housing and domestic conditions of at least 50 families of oil workers, carry out 150,000 rubles worth of capital repair on field quarters, and continue other work to improve conditions at Neftyanyye Kamni.

11176

CSO: 1822/183

OIL AND GAS

UDC 338.622.276.279

AZERBAIJAN OIL, GAS INDUSTRY DEVELOPMENT

Baku AZERBAYDZHANSKOYE NEFTYANOYE KHOZYAYSTVO in Russian No 12, Dec 85 pp 49-52

[Article by M. A. Mamedov, AzSSR Gosplan Scientific Research Institute of Economics: "Economics and the Scientific Organization of Production and Labor: Some Questions in the Development of the Oil and Gas Industry of the Azerbaijan SSR"]

[Text] This article presents some of the results of the development of the oil- and gas-producing industry of the republic over the years of the 10th and three years of the current five-year plans, in which principal attention is devoted to the discovery of reasons for the decline in efficiency of certain industry sectors.

The development of the oil- and gas-producing industry has played a large role in the development of the economy of the republic. On this basis, considerable increase in the production of electricity, petrochemicals and chemicals have been achieved and major measures have been carried out for the gasification and electrification of the municipal economy and the creation of living comfort for the population of the republic.

Over the last 15 years, however, the production of oil (and condensate) has decreased by 1.5 times, while the production of gas has increased by 2.5 times. Thus, by five-year plan, the decline in the level of oil production totaled 3.0 million tons over the 9th Five-Year Plan, 2.5 over the 10th and 2.0 over three years of the 11th. The rate of decline has increased on the average from 3.6% to 4.4% in the 9th and 10th five-year plans respectively. Meanwhile, the average yearly rate of growth in gas production totaled 10.7% over the 9th Five-Year Plan, 6.6% over the 10th and 4.8% over three years of the 11th.

Thanks to the growth in gas production, the total production of hydrocarbons has grown by 0.6% overall compared with 1970.

The research demonstrated that negative factors leading to difficulties in raising future oil production are characteristic of the republic's oil- and gas-producing industry. Thus, for example, the overall rate of growth in active oil reserves (those being extracted) for the republic as a whole lagged

behind production and a reduction occurred in the exploitation of active reserves.

One of the main reasons that the growth in active reserves lags the rate of production is a decline in the rate of exploratory drilling and introduction of new capacity into operation. The amount of exploratory drilling in the 10th Five-Year Plan has decreased by 38.3% overall across the republic compared to the 9th, including by 43.9% in the Azneft [Azerbaijan Oil] P/O [Production Association] and 32.6% in the Kasmorneftegazprom VPO [Caspian Sea Oil and Gas Industry All-Union Production Association], and has fallen by 7.0%, 16.3% and 13.7% respectively over the three years of the 11th Five-Year Plan with the concurrent non-fulfillment of plan targets.

Moreover, the preparation of oil reserves (by sum of yearly plans) was considerably less than planned, since along with the 70-95% fulfillment of the plan for exploratory drilling, the planned efficiency of exploratory drilling was also not achieved.

Such a situation is a result of the unsatisfactory organization of labor and violations of the technology of drilling operations. For example, in the time distribution of operational drilling for the Azneft P/O, calendar production time over the three years of the 11th Five-Year Plan alone decreased by 6.9% and totaled 75.7% in 1983, while in exploratory drilling it increased by 2.2% and in 1983 totaled 76.5%.

Organizational downtime in operational and exploratory drilling in 1983 totaled 84,800 and 51,400 hours respectively, or 17.1% and 15.3% of all calendar time. These indicators were equal to 54,700 and 55,400 hours, or 12.7% and 18.5%, respectively for the Kasmorneftegazprom VPO.

The technical and economic indicators of well construction still significantly lag average national values. Thus, over the years 1978-83, the commercial rate of exploratory drilling in the Azneft P/O increased only by a total of 8.1% (from 197 to 213 meters per standard-month) and conversely in operational drilling decreased by 14.5% (from 516 to 441 meters per standard-month), and decreased by 0.5% (from 202 to 201 meters per standard-month) and by 9.8% (from 376 to 339 meters per standard-month) in the Kasmorneftegazprom VPO respectively.

Increasing the economic efficiency of drilling operations in the future will depend greatly on conducting measures to reduce unproductive expenditures of time by improving the organization of labor and management, the timely and regular supplying of materials and machinery to drilling enterprises, observing the technology of well drilling and widely disseminating the operational experience of leading enterprises.

A decrease in the supply of producing oil reserves and an increase in the rate of extraction in the indicated period led to an increase in productivity decline of the old well stock. In the resultant situation, an unfavorable correlation arose in the 10th Five-Year Plan between the growth in new oil production capacity by introducing new wells and expending this capacity to compensate for the productivity decline of the old well stock.

The expenditure of new capacity to compensate for a production decline in the old well stock is increasing by years, and, moreover, a systematic reduction in the yields of new wells is occurring due to the intensive development of active fields and a powerful growth in water encroachment, as a result of which the operating expenditures are increasing per 1 ton increase in oil production.

One of the reasons for the non-fulfillment of the oil production plan is a shortfall in machinery. The oil- and gas-producing industry of the republic experienced great difficulties in the 9th Five-Year Plan in material and technical supply, manifested in the shortfall of materials versus allotted funds and the violation of supply schedules. Over three years of the 11th Five-Year Plan alone, the Azneft P/O did not receive 59,400 subsurface pumps, 7,600 units of pump and compressor pipe, 64,000 sucker rods and 40,000 V-belts, and the Kasmorneftegazprom VPO 15,000 sucker rods etc. versus allotted funds. The lack of pipe was often compensated for by decreasing the amortization standards. The industry is in constant need of an increase in the amount of subsurface and capital repair.

Over three years of the 11th Five-Year Plan, the amount of subsurface repairs in the Azneft P/O totaled 296,700 and capital repairs 9,000, and 29,500 and 3,400 respectively for the Kasmorneftegazprom VPO.

The large number of subsurface repairs in the Azneft P/O is explained basically by the fact that approximately 80% of the wells on the Apsheron Peninsula have been in long-term operation, as a consequence of which their repair grows more complicated every year. Moreover, the established amortization standard for well capital repairs does not cover the need for funds to carry out repairs. It is impossible to reduce the amount of repairs, since this could have a substantial effect on the level of oil production.

At the same time, the quality of the production output of related industry sectors also has a negative effect on well operation. Thus, the poor quality of subsurface pumps, pump and compressor pipe and V-belts makes the oil production workers' work more difficult. An analysis of the types of repairs shows that only four types of repair comprise roughly 70% of the total number of repairs. These are the replacement of pumps--25-30%, the flushing of sand bridges--15-20%, and the elimination of pipe leaks--15-20%, which lead to the loss of a significant quantity of oil.

The development of the oil- and gas-producing industry of the republic in the 10th Five-Year Plan was accompanied by a significant increase in capital investment compared to the 9th Five-Year Plan. Over this period the amount of capital investment increased by 1.42 times. Moreover, the proportionate capital investment per meter of drilling in the 9th Five-Year Plan increased by 1.43 and 1.07 times in operational and exploratory drilling respectively in the Azneft P/O, and by 2.36 and 1.60 times in the Kasmorneftegazprom VPO. Moreover, the return on investment decreased by 1.1 times in both associations.

Over the past three years of the 11th Five-Year Plan, the following data is typical of the variation in the productivity of labor: the productivity of labor declined by 6.4% overall across the republic, including by 13.4% in the Azneft P/O and by 5.3% in the Kasmorneftegazprom VPO.

Over the years 1976-83, an increase in geological and technical measures and current repairs, a decline in yields of the operating oil well stock, an increase in the water encroachment of producible output and an increase in the cost of machinery and materials for the oil industry led to an increase in the cost of 1 ton of oil for the Azneft P/O and the Kasmorneftegazprom VPO.

Summing up the development of the oil- and gas-producing industry of the republic over the years of the 10th Five-Year Plan and three years of the 11th, it can be stated that under conditions of a decrease in the introduction of new capacity (new fields), the decline in production was the result of a decrease in the productivity of the well stock and a reduction in the yield of new wells in developed areas.

It should also be added that due to the high degree of depletion of industry reserves in the principal fields of Balakhany--Sabunchi--Ramana, Neftyanyye Kamni, Peschanyy-more, Sangachaly-more--Duvanny-more--Bulla Island and Kyurovdag which produced approximately 60% of oil production (for the republic), a significant decrease in oil production is expected in the 12th Five-Year Plan which will be 10.3% of the 1980 level. Thus, the chief difficulty in developing the oil- and gas-producing industry in the 12th Five-Year Plan consists of stabilizing oil production in the principal fields. Along with this, a paramount task is the further intensive development of oil production in old areas to fill in its decrease and ensure overall growth in the republic.

In this regard, the further stabilization and growth of oil production in the republic in the 12th Five-Year Plan and in the future will be linked to the rapid development of geological exploratory operations with the aim of discovering new capacity, as well as to the execution of scientific research work on drawing up an integrated scientific and technical program that provides for the intensification of oil-field development and an increase in oil-recovery formations as well as the creation of productive reserves that guarantee the industry's fulfillment of the yearly, five-year and long-term economic plans.

The research shows that the maximum amount of current potential resources per square kilometer is located in Prikaspiysko-Kubinskiy, Sredne-Kubinskiy and Zapadnyy rayons (in the area between the Kura and Iori rivers) of Azerbaijan, which makes it possible to consider the indicated rayons as the most promising. It is therefore necessary to strengthen prospecting and exploratory work for oil and gas in precisely these rayons and in the sea in the 12th Five-Year Plan. The principal growth in oil production in the upcoming five-year plan should be obtained in the Field imeni April 28th, Shakhovo-more, imeni Kaverochkin, Neftyanyye Kamni-2, Yuzhnaya, Muradkhanly, Zardob, Tarsdallyar etc. fields.

To ensure the successful stabilization and growth of oil production in the republic (basically in the sea areas) in the 12th Five-Year Plan and the future, it is necessary to increase the amount of exploratory drilling by 1.6-2.0 times, and the amount of operational drilling by 1.4-1.8 times, compared to 1980. This requires a radical improvement in the organization of drilling operations and a significant enhancement of their technical and economic indicators by incorporating the achievements of scientific and technical progress, and, in particular, fundamentally new design solutions for improving and creating powerful new technical equipment and technology and the planning and construction of technical and hydro-technical structures for various purposes.

An increase in the amount of drilling operations should be achieved, basically, by the maximum utilization of internal resources and an increase in the efficiency of drilling operations.

The level of drilling operations achieved and the technical base of the republic cannot provide for the fulfillment of the projected volumes of drilling operations without a radical technical retooling and an improvement in the organization and management of production.

Paramount in the resolution of the problems of technical retooling are maritime oil- and gas-producing formations, since their surveying and development will in the future determine the strategy of industry development. In drilling operations plans, it is necessary to stipulate a sharp increase in the amount of survey and exploratory drilling with the aid of floating drilling rigs (FDR), for which it is necessary to bring the fleet up to 30-35 units. The fleet of Shelf-2-class drilling rigs should be increased, which will make possible a significant expansion of the zone of survey and exploratory operations and a more intensive filling in of industrial oil and gas reserves.

To decrease the rate of decline in oil production, and to stabilize it in the future at fields that have been operated for a long time, it is necessary to expand the scale of thermal methods of increasing oil recovery in formations and to drill new wells.

The results of experimental industrial operations in the Khorasany--Koshanaur, Binagadi--Kirmaku, Puta--Kushkhana--Umbaki and Artem Island fields shows that tertiary methods of increasing oil recovery in formations can be a substantial reserve for stabilizing oil production in older areas.

COPYRIGHT: AZERBAJDZHANSKOYE NEFTYANOYE KHOZYAYSTVO 1985

12821
CSO: 1822/203

OIL, GAS DRILLING INDICATORS IN AZERBAIJAN

Extraction, January-July

Baku VYSHKA in Russian 9 Aug 85 p 1

[Article: "Oil and Gas -- How Extraction Is Going"]

[Text] Data from AzSSR Central Statistical Administration on fulfillment of oil and gas extraction plan for the Azneft Association and VPO [All-Union Production Association] Kasporneftegazprom (in percentages) for January-July 1985.

	July		Jan-July	
	oil	gas	oil	gas
Объединение «Азнефт» (а)	91,9	102,6	95,0	104,0
(б)НГДУ «Лениннефт» (начальник Ширинов Я., секретарь парторганизации Махмудов Э.)	90,2	100,3	94,4	102,1
(с)НГДУ имени 26 бакинских комиссаров (т.т. Багиев А., Мустафаев Ч.)	100,1	100,6	100,5	102,4
(d)НГДУ «Орджоникидзе нефть» (т.т. Тагиев З., Рагимов Р.)	101,1	109,3	98,2	109,7
(e)НГДУ «Карадагнефт» (т.т. Керимов К., Ларина Л.)	100,7	100,4	101,4	102,4
(f)НГДУ «Кировнефт» (т.т. Мамедов Т., Ибрагимов И.)	102,4	104,2	98,2	102,0
(g)НГДУ «Азизбековнефт» (т.т. Гасанов Т., Бахбанлы А.)	100,2	116,4	100,0	124,6
(h)НГДУ «Сказаннефт» (т.т. Мамедов Р., Бекдамиров М.)	100,0	100,0	95,4	100,6
(i)НГДУ «Ширваннефт» (т.т. Мамедов В., Гейдаров З.)	85,1	100,4	93,3	101,8
(j)НГДУ «Сальянынефт» (т.т. Гусейнов Ф., Гасанов Г.)	100,1	103,6	96,4	105,0
(k)НГДУ «Нефтечала нефть» (т.т. Мамедов С., Керимов Р.)	100,0	106,8	100,1	109,3
(l)НГДУ «Мурадханлынефт» (т.т. Оруджев Б., Бабеев И.)	47,4	100,0	61,7	100,0
ВПО «Каспморнефтегазпром» (м)	100,5	100,9	100,6	101,3
(n)ПО имени XXII съезда КПСС (директор т. Ибрагимов С., секретарь парторганизации т. Зайдов Н.)	100,0	100,0	100,6	110,4
(o)НГДУ «Артемнефтегаз» (т.т. Халилов Б., Азизов Т.)	110,0	155,3	102,4	152,1
(p)НГДУ имени Серебровского (т.т. Мусаев Ф., Гридневский Н.)	112,8	102,9	107,2	103,1
(q)НГДУ имени Н. Нариманова (т.т. Гумбатов Г., Мамедов Э.)	93,6	100,0	97,6	100,5
(r)НГДУ Булла-море имени 50-летия СССР (т.т. Мамедов Б., Мирзабеков Б.)	100,0	95,8	101,0	96,3
Итого по объединениям: (с)	97,9	101,0	98,8	101,4

Key: (a) Azneft Association;

(b) Leninneft NGDU [Oil and Gas Extraction Administration] (chief Ya. Shirinov and secretary of party organization E. Makhmudov);

(c) NGDU imeni 26 bakinskikh komissarov (Comrades A. Bagiyev and Ch. Mustafayev);

(d) Ordzhonikidzeneft NGDU (Comrades Z. Tagiyev and R. Ragimov);

(e) Karadagneft NGDU (Comrades K. Kerimov and G. Israfilov);

(f) Kirovneft NGDU (Comrades T. Mamedov and I. Ibragimov);

(g) Azizbekovneft NGDU (Comrades T. Gasanov and A. Bakhanly);

(h) Skazanneft NGDU (Comrades R. Mamedov and M. Bekdamirov);

(i) Shirvanneft NGDU (Comrades V. Mamedov and Z. Geydarov);

(j) Salyanyneft NGDU (Comrades F. Guseynov and A. Isayev);

(k) Neftechalanefteft NGDU (Comrades S. Mamedov and R. Kerimov);

(l) Muradkhanlyneft NGDU (Comrades B. Orudzhev and I. Babayev);

(m) VPO Kasporneftegazprom;

(n) PO imeni XXII syezda KPSS (Comrades S. Ibragimov and N. Zaidov);

(o) Artemneftegaz NGDU (Comrades B. Khalilov and T. Azizov);

(p) NGDU imeni Serebrovskiy (Comrades R. Kurbanov and Sh. Akhundov);

(q) NHDU imeni N. Narimanov (Comrades G. Gumbatov and E. Mamedov);

(r) NGDU Bulla-more imeni 50-letiya SSSR (Comrades B. Mamedov and A. Nadzharov);

(s) Total for Associations.

Extraction, January-August

Baku VYSHKA in Russian 10 Sep 85 p 1

[Article: "Oil and Gas -- How Extraction Is Going"]

[Text] Data from AzSSR Central Statistical Administration on fulfillment of oil and gas extraction plan for the Azneft Association and VPO [All-Union Production Association] Kasporneftegazprom (in percentages) for January-August 1985.

	August		Jan-Aug	
	oil	gas	oil	gas
Объединение «Азнефть» (а)	91,6	100,1	94,5	103,5
(b) НГДУ «Лениннефть» (начальник Ширин Я., секретарь парторганизации Махмудов Э.)	87,5	100,1	93,5	101,8
(c) НГДУ имени 26 бакинских комиссаров (т. Багиев А., Мустафаев Ч.)	100,0	100,0	100,5	102,1
(d) НГДУ «Орджоникидзе нефть» (т. Тагиев З., Рагимов Р.)	101,9	108,7	98,7	109,6
(e) НГДУ «Карадаг нефть» (т. Керимов К., Ларина Л.)	100,7	101,1	101,3	102,2
(f) НГДУ «Киров нефть» (т. Мамедов Т., Ибрагимов И.)	106,8	106,9	99,3	102,6
(g) НГДУ «Азизбеков нефть» (т. Гасанов Т., Бахбанлы А.)	100,0	117,6	100,0	123,7
(h) НГДУ «Сказан нефть» (т. Мамедов Р., Бекдамиров М.)	86,5	76,9	94,3	97,6
(i) НГДУ «Ширван нефть» (т. Мамедов В., Гейдаров З.)	87,5	100,0	92,5	101,5
(j) НГДУ «Сальян нефть» (т. Гусейнов Ф., Гасанов Г.)	110,5	104,0	98,2	104,8
(k) НГДУ «Нефtechалан нефть» (т. Мамедов С., Керимов Р.)	100,0	103,5	100,1	108,7
(l) НГДУ «Мурадханлы нефть» (т. Оруджев Б., Бабаев И.)	30,9	100,0	56,4	100,0
ВПО «Каспморнефтегазпром» (m)	101,2	101,6	100,7	101,3
(n) ПО имени XXII съезда КПСС (директор т. Ибрагимов С., секретарь парторганизации т. Зайдов Н.)	100,0	100,0	100,5	108,7
(o) НГДУ «Артемнефтегаз» (т. Халилов Б., Азизов Т.)	103,4	158,9	102,5	152,9
(p) НГДУ имени Серебровского (т. Курбанов Р., Гридновский Н.)	104,9	103,5	106,9	103,1
(q) НГДУ имени Н. Нариманова (т. Гумбатов Г., Мамедов Э.)	100,0	100,0	97,9	100,4
(r) НГДУ Булла-море имени 50-летия СССР (т. Мамедов Б., Мирзабаков Б.)	109,2	96,9	102,0	96,4
Итого по объединениям: (s)	98,3	101,5	98,8	101,4

Key: (a) Azneft Association;

(b) Leninneft NGDU [Oil and Gas Extraction Administration] (chief Ya. Shirinov and secretary of party organization E. Makhmudov);

(c) NGDU imeni 26 bakinskikh komissarov (Comrades A. Bagiyev and Ch. Mustafayev);

(d) Ordzhonikidzeneft NGDU (Comrades Z. Tagiyev and R. Ragimov);

(e) Karadagneft NGDU (Comrades K. Kerimov and G. Israfilov);

(f) Kirovneft NGDU (Comrades T. Mamedov and I. Ibragimov);

(g) Azizbekovneft NGDU (Comrades T. Gasanov and A. Bakhanly);

(h) Skazanneft NGDU (Comrades R. Mamedov and M. Bekdamirov);

(i) Shirvanneft NGDU (Comrades V. Mamedov and Z. Geydarov);

(j) Salyanyneft NGDU (Comrades F. Guseynov and A. Isayev);

(k) Neftechalaneft NGDU (Comrades S. Mamedov and R. Kerimov);

(l) Muradkhanlyneft NGDU (Comrades B. Orudzhev and I. Babayev);

(m) VPO Kasporneftegazprom;

(n) PO imeni XXII syezda KPSS (Comrades S. Ibragimov and N. Zaidov);

(o) Artemneftegaz NGDU (Comrades B. Khalilov and T. Azizov);

(p) NGDU imeni Serebrovskiy (Comrades R. Kurbanov and Sh. Akhundov);

(q) NHDU imeni N. Narimanov (Comrades G. Gumbatov and E. Mamedov);

(r) NGDU Bulla-more imeni 50-letiya SSSR (Comrades B. Mamedov and A. Nadzharov);

(s) Total for Associations.

Extraction, January-September

Baku VYSHKA in Russian 6 Oct 85 p 3

[Article: "Oil and Gas -- How Extraction Is Going"]

[Text] Data from AzSSR Central Statistical Administration on fulfillment of oil and gas extraction plan for the Azneft Association and VPO [All-Union Production Association] Kasporneftegazprom (in percentages) for January-September 1985.

		Sep		Jan-Sep	
		oil	gas	oil	gas
Объединение «Азнефть» (а)		91,1	102,4	94,2	103,4
(b) НГДУ «Лениннефть»	(начальник Ширинов Я., секретарь парторганизации Махмудов Э.)	87,4	100,6	92,9	101,7
(c) НГДУ имени 26 бакинских комиссаров	(т. Багиев А., Мустафаев Ч.)	100,0	101,8	100,4	102,1
(d) НГДУ «Ордзоникидзе нефть»	(т. Тагиев З., Рагимов Р.)	101,2	110,8	99,0	109,7
(e) НГДУ «Карадагнефть»	(т. Керимов К., Ларина Л.)	101,4	100,3	101,3	102,1
(f) НГДУ «Кировнефть»	(т. Мамедов Т., Ибрагимов И.)	106,4	101,8	100,0	102,5
(g) НГДУ «Азизбековнефть»	(т. Гасанов Т., Бахбанлы А.)	100,0	110,3	100,0	122,3
(h) НГДУ «Сказаннефть»	(т. Мамедов Р., Бекдамиров М.)	79,8	102,0	92,7	98,1
(i) НГДУ «Ширваннефть»	(т. Мамедов, Гейдаров З.)	85,2	100,5	91,7	101,4
(j) НГДУ «Сальянынефть»	(т. Гусейнов Ф., Гасанов Г.)	100,8	102,5	98,5	104,6
(k) НГДУ «Нефтечаланефть»	(т. Мамедов С., Керимов Р.)	100,0	108,9	100,1	108,7
(l) НГДУ «Мурадханлынефть»	(т. Оруджев Б., Бабаев И.)	51,8	100,0	55,6	100,0
ВПО «Каспморнефтегазпром» (m)		100,1	101,8	100,6	101,4
(n) ПО имени XXII съезда КПСС	(директор т. Ибрагимов С., секретарь парторганизации т. Зайдов Н.)	97,6	100,0	100,1	107,5
(o) НГДУ «Артемнефтегаз»	(т. Халилов Б., Азизов Т.)	110,7	152,3	103,4	152,8
(p) НГДУ имени Серебровского	(т. Курбанов Р., Гридневский Н.)	114,3	104,6	107,7	103,3
(q) НГДУ имени Н. Нариманова	(т. Гумбатов Г., Мамедов Э.)	94,8	100,0	97,5	100,4
(r) НГДУ Булла-море имени 50-летия СССР	(т. Мамедов Б., Мирзабеков Б.)	120,8	96,6	103,7	96,4
итого по объединениям: (s)		97,4	101,8	98,6	101,5

Key: (a) Azneft Association;

(b) Leninneft NGDU [Oil and Gas Extraction Administration] (chief Ya. Shirinov and secretary of party organization E. Makhmudov);

(c) NGDU imeni 26 bakinskikh komissarov (Comrades A. Bagiyev and Ch. Mustafayev);

(d) Ordzhonikidzeneft NGDU (Comrades Z. Tagiyev and R. Ragimov);

(e) Karadagneft NGDU (Comrades K. Kerimov and G. Israfilov);

(f) Kirovneft NGDU (Comrades T. Mamedov and I. Ibragimov);

(g) Azizbekovneft NGDU (Comrades T. Gasanov and A. Bakhanly);

(h) Skazanneft NGDU (Comrades R. Mamedov and M. Bekdamirov);

(i) Shirvanneft NGDU (Comrades V. Mamedov and Z. Geydarov);

(j) Salyanyneft NGDU (Comrades F. Guseynov and A. Isayev);

(k) Neftechalanefteft NGDU (Comrades S. Mamedov and R. Kerimov);

(l) Muradkhanlyneft NGDU (Comrades B. Orudzhev and I. Babayev);

(m) VPO Kasporneftegazprom;

(n) PO imeni XXII syezda KPSS (Comrades S. Ibragimov and N. Zaidov);

(o) Artemneftegaz NGDU (Comrades B. Khalilov and T. Azizov);

(p) NGDU imeni Serebrovskiy (Comrades R. Kurbanov and Sh. Akhundov);

(q) NHDU imeni N. Narimanov (Comrades G. Gumbatov and E. Mamedov);

(r) NGDU Bulla-more imeni 50-letiya SSSR (Comrades B. Mamedov and A. Nadzharov);

(s) Total for Associations.

Extraction, January-October

Baku VYSHKA in Russian 15 Nov 85 p 2

[Article: "Oil and Gas -- How Extraction Is Going"]

[Text] Data from AzSSR Central Statistical Administration on fulfillment of oil and gas extraction plan for the Azneft Association and VPO [All-Union Production Association] Kasporneftegazprom (in percentages) for January-October 1985.

		Oct	Jan-Oct	oil	gas	oil	gas
Объединение «Азнефть» (a)				87,8	103,9	93,5	103,4
(b)	НГДУ «Лениннефть» (начальник Ширинов Я., секретарь парторганизации Махмудов Э.)	92,4	100,1	92,8	101,5		
(c)	НГДУ имени 26 бакинских комиссаров (т. Багийев А., Мустафаев Ч.)	100,0	101,9	100,4	102,1		
(d)	НГДУ «Орджоникидзе нефть» (т. Тагийев З., Рагимов Р.)	100,2	110,4	99,1	109,8		
(e)	НГДУ «Карадаг нефть» (т. Керимов К., Исрафилов Г.)	101,2	105,6	101,3	102,4		
(f)	НГДУ «Кировнефть» (т. Мамедов Т., Ибрагимов И.)	100,1	105,2	100,0	102,7		
(g)	НГДУ «Азизбековнефть» (т. Гасанов Т., Бахбанлы А.)	100,0	124,2	100,0	122,5		
(h)	НГДУ «Сказаннефть» (т. Мамедов Р., Бекдамиров М.)	82,3	101,3	91,6	98,4		
(i)	НГДУ «Ширваннефть» (т. Мамедов В., Гейдаров З.)	81,3	107,0	90,7	102,0		
(j)	НГДУ «Сальянынефть» (т. Гусейнов Ф., Исаяев А.)	100,0	100,1	98,6	104,1		
(k)	НГДУ «Нефtechаланефть» (т. Мамедов С., Керимов Р.)	100,0	103,3	100,1	108,1		
(l)	НГДУ «Мурадханлынефть» (т. Оруджев Б., Бабаев И.)	23,3	100,0	50,6	100,0		
ВПО «Каспморнефтегазпром» (m)		100,8	100,7	100,6	101,3		
(n)	ПО имени XXII съезда КПСС (т. Ибрагимов С., секретарь парторганизации Зайдов Н.)	100,0	100,0	100,1	106,5		
(o)	НГДУ «Артемнефтегаз» (т. Халилов Б., Азизов Т.)	100,0	154,7	103,1	153,0		
(p)	НГДУ имени Серебровского (т. Курбанов Р., Гридневский Н.)	108,9	103,1	107,8	103,3		
(q)	НГДУ имени Н. Нариманова (т. Гумбатов Г., Мамедов Э.)	94,4	97,8	97,2	100,1		
(r)	НГДУ Булла-море имени 50-летия СССР (т. Мамедов В., Мирзабеков Б.)	125,9	95,9	105,6	96,3		
Итого по объединениям: (s)		96,8	100,9	98,4	101,4		

Key: (a) Azneft Association;

(b) Leninneft NGDU [Oil and Gas Extraction Administration] (chief Ya. Shirinov and secretary of party organization E. Makhmudov);

(c) NGDU imeni 26 bakinskikh komissarov (Comrades A. Bagiyev and Ch. Mustafayev);

(d) Ordzhonikidzeneft NGDU (Comrades Z. Tagiyev and R. Ragimov);

(e) Karadagneft NGDU (Comrades K. Kerimov and G. Israfilov);

(f) Kirovneft NGDU (Comrades T. Mamedov and I. Ibragimov);

(g) Azizbekovneft NGDU (Comrades T. Gasanov and A. Bakhanly);

(h) Skazanneft NGDU (Comrades R. Mamedov and M. Bekdamirov);

(i) Shirvanneft NGDU (Comrades V. Mamedov and Z. Geydarov);

(j) Salyanyneft NGDU (Comrades F. Guseynov and A. Isayev);

(k) Neftechalaneft NGDU (Comrades S. Mamedov and R. Kerimov);

(l) Muradkhanlyneft NGDU (Comrades B. Orudzhev and I. Babayev);

(m) VPO Kasporneftegazprom;

(n) PO imeni XXII syezda KPSS (Comrades S. Ibragimov and N. Zaidov);

(o) Artemneftegaz NGDU (Comrades B. Khalilov and T. Azizov);

(p) NGDU imeni Serebrovskiy (Comrades R. Kurbanov and Sh. Akhundov);

(q) NHDU imeni N. Narimanov (Comrades G. Gumbatov and E. Mamedov);

(r) NGDU Bulla-more imeni 50-letiya SSSR (Comrades B. Mamedov and A. Nadzharov);

(s) Total for Associations.

Extraction, January-November

JPRS-UEN-86-009
15 April 1986

Baku VYSHKA in Russian 6 Dec 85 p 3

[Article: "Oil and Gas -- How Extraction Is Going"]

[Text] Data from AzSSR Central Statistical Administration on fulfillment of oil and gas extraction plan for the Azneft Association and VPO [All-Union Production Association] Kasporneftegazprom (in percentages) for January-November 1985.

		Nov		Jan-Nov	
		oil	gas	oil	gas
Объединение «Азнефть» (a)		82,7	105,0	92,5	103,6
(b) НГДУ «Лениннефть»	(начальник Ширинов Я., секретарь парторганизации Махмудов Э.)	76,6	88,3	91,4	100,3
(c) НГДУ имени 26 бакинских комиссаров	(тг. Багиев А., Мустафаев Ч.)	100,0	100,6	100,3	101,9
(d) НГДУ «Орджоникидзенефть»	(тг. Тагиев З., Рагимов Р.)	100,0	110,5	99,2	109,8
(e) НГДУ «Карадагнефть»	(тг. Керимов К., Исрафилов Г.)	100,5	106,1	101,2	102,6
(f) НГДУ «Кировнефть»	(тг. Мамедов Т., Ибрагимов И.)	100,1	102,1	100,1	102,7
(g) НГДУ «Азизбековнефть»	(тг. Гасанов Т., Бахбанлы А.)	87,3	126,9	98,9	122,9
(h) НГДУ «Смазаннефть»	(тг. Мамедов Р., Бекдамиров М.)	81,3	110,1	90,7	99,4
(i) НГДУ «Ширваннефть»	(тг. Мамедов В., Гейдаров З.)	83,9	106,0	90,1	102,3
(j) НГДУ «Сальянынефть»	(тг. Гусейнов Ф., Исаев А.)	100,0	103,2	98,8	104,0
(k) НГДУ «Нефtechаланефть»	(тг. Мамедов С., Керимов Р.)	35,6	104,9	94,3	107,7
(l) НГДУ «Мурадханлынефть»	(тг. Оруджев Б., Бабаев И.)	18,6	100,0	46,3	100,0
ВПО «Каспморнефтегазпром» (m)		100,0	99,2	100,6	101,1
(n) ПО имени XXII съезда КПСС	(тг. Ибрагимов С., секретарь парторганизации Зайдов Н.)	100,0	100,0	100,1	105,7
(o) НГДУ «Артемнефтегаз»	(тг. Халилов Б., Азизов Т.)	100,0	152,8	102,8	153,0
(p) НГДУ имени Серебровского	(тг. Курбанов Р., Ахундов Ш. А.)	111,3	103,6	108,1	103,3
(q) НГДУ имени Н. Нариманова	(тг. Гумбатов Г., Мамедов Э.)	90,5	89,4	96,7	99,1
(r) НГДУ Булла-море имени 50-летия СССР	(тг. Мамедов Б., Наджафов А. М.)	121,4	94,6	106,8	96,2
Итого по объединениям: (s)		94,7	99,5	98,1	101,2

Key: (a) Azneft Association;

(b) Leninneft NGDU [Oil and Gas Extraction Administration] (chief Ya. Shirinov and secretary of party organization E. Makhmudov);

(c) NGDU imeni 26 bakinskikh komissarov (Comrades A. Bagiyev and Ch. Mustafayev);

(d) Ordzhonikidzeneft NGDU (Comrades Z. Tagiyev and R. Ragimov);

(e) Karadagneft NGDU (Comrades K. Kerimov and G. Israfilov);

(f) Kirovneft NGDU (Comrades T. Mamedov and I. Ibragimov);

(g) Azizbekovneft NGDU (Comrades T. Gasanov and A. Bakhanly);

(h) Skazanneft NGDU (Comrades R. Mamedov and M. Bekdamirov);

(i) Shirvanneft NGDU (Comrades V. Mamedov and Z. Geydarov);

(j) Salyanyneft NGDU (Comrades F. Guseynov and A. Isayev);

(k) Neftechalaneft NGDU (Comrades S. Mamedov and R. Kerimov);

(l) Muradkhanlyneft NGDU (Comrades B. Orudzhev and I. Babayev);

(m) VPO Kasporneftegazprom;

(n) PO imeni XXII syezda KPSS (Comrades S. Ibragimov and N. Zaidov);

(o) Artemneftegaz NGDU (Comrades B. Khalilov and T. Azizov);

(p) NGDU imeni Serebrovskiy (Comrades R. Kurbanov and Sh. Akhundov);

(q) NHDU imeni N. Narimanov (Comrades G. Gumbatov and E. Mamedov);

(r) NGDU Bulla-more imeni 50-letiya SSSR (Comrades B. Mamedov and A.

Nadzharov);

(s) Total for Associations.

Baku VYSHKA in Russian 12 Jan 86 p 1

[Article: "Oil and Gas -- How Extraction Is Going"]

[Text] Data from AzSSR Central Statistical Administration on fulfillment of oil and gas extraction plan for the Azneft Association and VPO [All-Union Production Association] Kasporneftegazprom (in percentages) for January-December 1985.

	Dec		Jan-Dec	
	oil	gas	oil	gas
(a) Объединение «Азнефть»	74,1	103,2	90,9	103,5
(b) НГДУ «Лениннефть» (начальник Ширинов Я., секретарь парторганизации Махмудов Э.)	75,6	103,0	90,0	100,5
(c) НГДУ имени 26 бакинских комиссаров (т. Багнев А., Мустафаев Ч.)	100,0	100,0	100,3	101,8
(d) НГДУ «Орджоникидзефть» (т. Тагнев З., Рагимов Р.)	83,4	112,8	97,8	110,1
(e) НГДУ «Карадагнефть» (т. Керимов К., Исрафилов Г.)	100,9	103,5	101,2	102,7
(f) НГДУ «Кировнефть» (т. Мамедов Т., Ибрагимов И.)	79,7	102,6	98,3	102,7
(g) НГДУ «Азизбековнефть» (т. Гасанов Т., Бахбанлы А.)	71,3	133,4	96,5	123,7
(h) НГДУ «Сказаннефть» (т. Мамедов Р., Бекдамиров М.)	86,6	100,1	90,4	99,5
(i) НГДУ «Ширваннефть» (т. Мамедов В., Гейдаров З.)	64,5	100,5	87,9	102,2
(j) НГДУ «Сальянынефть» (т. Гусейнов Ф., Исаяев А.)	83,2	101,1	97,4	103,8
(k) НГДУ «Нефтечаланефть» (т. Мамедов С., Керимов Р.)	100,6	109,0	94,8	107,8
(l) НГДУ «Мурадханлынефть» (т. Оруджев Б., Бабаяев И.)	11,6	100,0	42,1	100,0
VPO «Каспморнефтегазпром» (m)	98,1	100,0	100,3	101,0
(n) ПО имени XXII съезда КПСС (т. Ибрагимов С., секретарь парторганизации Зайдов Н.)	99,1	100,0	100,0	105,1
(o) НГДУ «Артемнефтегаз» (т. Халилов Б., Азизов Т.)	100,0	158,8	102,6	153,5
(p) НГДУ имени Серебровского (т. Курбанов Р., Ахундов Ш.)	108,2	105,4	108,1	103,5
(q) НГДУ имени Н. Нариманова (т. Гумбатов Г., Мамедов Э.)	83,5	92,2	95,6	98,5
(r) НГДУ Булла-море имени 50-летия СССР (т. Мамедов Б., Наджафов А.)	122,2	93,4	108,0	95,9
Итого по объединениям: (s)	98,8	100,2	97,4	101,1

Key: (a) Azneft Association;

(b) Leninneft NGDU [Oil and Gas Extraction Administration] (chief Ya. Shirinov and secretary of party organization E. Makhmudov);

(c) NGDU imeni 26 bakinskikh komissarov (Comrades A. Bagiyev and Ch. Mustafayev);

(d) Ordzhonikidzeneft NGDU (Comrades Z. Tagiyev and R. Ragimov);

(e) Karadagneft NGDU (Comrades K. Kerimov and G. Israfilov);

(f) Kirovneft NGDU (Comrades T. Mamedov and I. Ibragimov);

(g) Azizbekovneft NGDU (Comrades T. Gasanov and A. Bakhanly);

(h) Skazanneft NGDU (Comrades R. Mamedov and M. Bekdamirov);

(i) Shirvanneft NGDU (Comrades V. Mamedov and Z. Geydarov);

(j) Salyanyneft NGDU (Comrades F. Guseynov and A. Isayev);

(k) Neftechalaneft NGDU (Comrades S. Mamedov and R. Kerimov);

(l) Muradkhanlyneft NGDU (Comrades B. Orudzhev and I. Babayev);

(m) VPO Kasporneftegazprom;

(n) PO imeni XXII syezda KPSS (Comrades S. Ibragimov and N. Zaidov);

(o) Artemneftegaz NGDU (Comrades B. Khalilov and T. Azizov);

(p) NGDU imeni Serebrovskiy (Comrades R. Kurbanov and Sh. Akhundov);

(q) NHDU imeni N. Narimanov (Comrades G. Gumbatov and E. Mamedov);

(r) NGDU Bulla-more imeni 50-letiya SSSR (Comrades B. Mamedov and A. Nadzharov);

(s) Total for Associations.

Drilling, January-July

Baku VYSHKA in Russian 10 Aug 85 p 1

[Article: "How Drilling Is Going"]

[Text] Data from AzSSR Central Statistical Administration on fulfillment (in percentage) of drilling plans of the Azneft Association and the VPO Kasporneftegazprom for January-July 1985.

	July		Jan-July	
	(a) общая проходка	(b) разведочная в т.ч.	(a) общая проходка	(b) разведочная в т.ч.
Объединение «Азнефть» (c)	102,9	64,7	104,0	94,7
(d) Апшеронское УБР (т.т. Хасмамедов А., Мамедов М.)	108,7	—	111,3	—
(e) Сназанское УБР (т.т. Гаджиев А., Гувветов И.)	101,2	64,2	85,8	44,9
(f) Али-Байрамлинское УБР (т.т. Алекперов Н., Исмаилов Н.)	127,3	22,0	118,2	207,6
(g) Прикуринское УБР (и. о. т. Абасов А.)	100,6	—	101,7	21,3
(h) Кюрсангинское УБР (и. о. т. Дашдамиров Х., Назиров А.)	100,5	52,9	100,9	139,0
(i) Джейранчельское УБР (т.т. Мехтиев Ю.)	64,4	64,4	96,0	96,0
(j) Джарлинское УБР (т.т. Велиев Р., Джафаров М.)	100,9	100,9	100,5	102,2
ВПО «Каспморнефтегазпром» (k)	89,2	68,2	81,7	59,6
(l) МУБР «Нефтяные Камни» (т.т. Абасов О., Дадашев К.)	67,4	—	96,0	100,4
(m) МУБР «Песчанинское» (т.т. Мехтиев Ш., Мамедов Б.)	102,1	—	93,9	—
(n) МУБР «Сангачальское» (т.т. Магerrамов С., Гаджиев Б.)	100,4	—	82,5	—
(o) МУБР «Приморское» (т.т. Исмаилов А., Котова М.)	100,1	78,0	92,7	82,8
(p) МУБР «Булла» (т.т. Мамедов М., Ахмедов В.)	100,6	75,3	56,2	49,9
(q) МУБР «Бухта Ильича» (т.т. Гасымов А., Гусейнов И.)	100,2	109,2	116,6	98,8
(r) МУБР со СТС (т.т. Сафаров Ч., Мурадвердиев А.)	100,2	100,2	83,3	83,3
Итого по объединениям: (s)	96,7	66,8	93,7	73,7

- Key: (a) Total Drilling;
 (b) Of That, Exploratory Drilling;
 (c) Azneft Association;
 (d) Apsheron UBR [Drilling Administration] (Comrades A. Khasmamedov and M. Mamedov);
 (e) Snazanskoye UBR (Comrades A. Gadzhiyev and I. Guvvetov);
 (f) Ali-Bayramli UBR (Comrades N. Alekperov and N. Ismaylov);
 (g) Prikurinskoye UBR (acting official Comrade A. Abasov);
 (h) Kyusanginskoye UBR (acting officials Kh. Dashdamirov and A. Nazirov);
 (i) Dzheyranchelskoye UBR (Comrade Yu. Makhtiyev);
 (j) Dzharlinskoye UBR (Comrades R. Veliyev and M. Dzhaфарov);
 (k) VPO Kasporneftegazprom;
 (l) Neftyanyye Kamni MUBR [M___ Drilling Administration, full expansion unknown] (Comrades O. Abasov and K. Dadashev);
 (m) Peschanskoye MUBR (Comrades Sh. Mekhtiyev and B. Mamedov);
 (n) Sangachaly MUBR (Comrades S. Magerramov and B. Gadzhiyev);
 (o) Primorskoye MUBR (Comrades A. Ismaylov and M. Kotova);
 (p) Bulla MUBR (Comrades M. Mamedov and V. Akhmedov);
 (q) Bukhta Ilichy MUBR (Comrades A. Gasymov and I. Guseynov);
 (r) MUBR so STS [expansion unknown] (Comrades Ch. Safarov and A. Muradverdiyev);
 (s) Total for Associations.

Drilling, January-August

Baku VYSHKA in Russian 11 Sep 85 p 3

[Article: "How Drilling Is Going"]

[Text] Data from AzSSR Central Statistical Administration on fulfillment (in percentage) of drilling plans of the Azneft Association and the VPO Kasporneftegazprom for January-August 1985.

	Aug		Jan-Aug	
	проходня общая (a)	в т. ч. развед. доцныя (b)	проходня общая (a)	в т. ч. развед. доцныя (b)
Объединение «Азнефть» (c)	101,1	63,7	103,6	93,0
(d) Апшеронское УБР (т.т. Хасмамедов А., Мамедов М.)	104,1	—	110,3	—
(e) Сназанское УБР (т.т. Гаджиев А., Гувветов И.)	101,1	18,9	87,9	40,1
(f) Али-Байрамлинское УБР (т.т. Алекперов Н., Исмаилов Н.)	116,9	125,0	118,0	197,9
(g) Прикуринское УБР (т.т. Абасов А.)	63,3	—	95,6	16,2
(h) Кюрсангинское УБР (т.т. Дашдамиров Х., Назиров А.)	118,9	200,4	103,1	180,5
(i) Джейранчельское УБР (т.т. Мехтиев Ю.)	48,8	48,8	89,4	89,4
(j) Джарлинское УБР (т.т. Велиев Р., Джафаров М.)	100,3	100,3	100,4	101,9
ВПО «Каспморнефтегазпром» (k)	83,7	53,2	81,9	58,8
(l) МУБР «Нефтяные Камни» (т.т. Аббасов О., Дадашев К.)	100,1	—	96,5	100,4
(m) МУБР «Песчанинское» (т.т. Мехтиев Ш., Мамедов Б.)	58,4	—	89,4	—
(n) МУБР «Сангачальское» (т.т. Магеррамов С., Гаджиев Б.)	100,1	—	85,0	—
(o) МУБР «Приморское» (т.т. Исмаилов А., Котова М.)	100,0	58,8	93,8	79,3
(p) МУБР «Булла» (т.т. Мамедов М., Ахмедов В.)	103,7	83,4	63,0	54,3
(q) МУБР «Бухта Ильича» (т.т. Гасымов А., Гусейнов И.)	109,5	47,7	115,8	93,1
(r) МУБР со СТС (т.т. Сафаров Ч., Мурадвердиев А.)	47,4	47,4	78,3	78,3
Итого по объединениям: (s)	92,9	57,7	93,6	72,6

- Key: (a) Total Drilling;
 (b) Of That, Exploratory Drilling;
 (c) Azneft Association;
 (d) Apsheron UBR [Drilling Administration] (Comrades A. Khasmamedov and M. Mamedov);
 (e) Snazanskoye UBR (Comrades A. Gadzhiyev and I. Guvvetov);
 (f) Ali-Bayramli UBR (Comrades N. Alekperov and N. Ismaylov);
 (g) Prikurinskoye UBR (Comrade A. Abasov);
 (h) Kyusanginskoye UBR (Comrades Kh. Dashdamirov and A. Nazirov);
 (i) Dzheyranchelskoye UBR (Comrade Yu. Makhtiyev);
 (j) Dzharlinskoye UBR (Comrades R. Veliyev and M. Dzhaфарov);
 (k) VPO Kasporneftegazprom;
 (l) Neftyanyye Kamni MUBR [M___ Drilling Administration, full expansion unknown] (Comrades O. Abasov and K. Dadashev);
 (m) Peschanskoye MUBR (Comrades Sh. Mekhtiyev and B. Mamedov);
 (n) Sangachaly MUBR (Comrades S. Magerramov and B. Gadzhiyev);
 (o) Primorskoye MUBR (Comrades A. Ismaylov and M. Kotova);
 (p) Bulla MUBR (Comrades M. Mamedov and V. Akhmedov);
 (q) Bukhta Ilicha MUBR (Comrades A. Gasymov and I. Guseynov);
 (r) MUBR so STS [expansion unknown] (Comrades Ch. Safarov and A. Muradverdiyev);
 (s) Total for Associations.

Drilling, January-September

Baku VYSHKA in Russian 7 Oct 85 p 1

[Article: "How Drilling Is Going"]

[Text] Data from AzSSR Central Statistical Administration on fulfillment (in percentage) of drilling plans of the Azneft Association and the VPO Kasporneftegazprom for January-September 1985.

	Sep		Jan-Sep	
	проходка общая (a)	в т. ч. развед- очная (b)	проходка общая (a)	в т. ч. развед- очная (b)
Объединение «Азнефть» (c)	103,8	83,1	103,6	91,7
(d) Апшеронское УБР (т.т. Хасмамедов А., Мамедов М.)	105,5	—	109,7	—
(e) Сиазанское УБР (т.т. Гаджиев А., Аббасов Б.)	101,3	49,0	89,6	41,4
(f) Али-Байрамлинское УБР (т.т. Алекперов Н., Исмаилов Н.)	100,4	22,3	115,7	125,2
(g) Прикуринское УБР (т.т. Абасов А., Керимов Т.)	33,2	40,7	87,2	20,8
(h) Кюрсангинское УБР (и. о. т. Дашдамиров Х., Назиров А.)	137,0	243,4	106,6	184,5
(i) Джейранчельское УРБ (т.т. Мехтиев Ю.)	100,9	100,9	90,5	90,5
(j) Джарлинское УРБ (т.т. Велиев Р., Джафаров М.)	101,8	101,8	100,6	101,9
ВПО «Каспморнефтегазпром» (k)	70,2	40,1	80,6	56,6
(l) МУБР «Нефтяные Камни» (т.т. Абасов О., Дадашев К.)	101,1	—	97,0	100,4
(m) МУБР «Песчанинское» (т.т. Мехтиев Ш., Мамедов Б.)	100,4	—	90,6	—
(n) МУБР «Сангачальское» (т.т. Магеррамов С., Гаджиев Б.)	56,1	—	81,4	—
(o) МУБР «Приморское» (т.т. Исмаилов А., Котова М.)	43,0	42,9	87,7	74,9
(p) МУБР «Булла» (т.т. Мамедов М., Ахмедов В.)	48,6	28,4	61,2	51,1
(q) МУБР «Бухта Ильича» (т.т. Гасымов А., Гусейнов И.)	134,9	63,8	117,8	90,2
(r) МУБР со СТС (т.т. Сафаров Ч., Мурадвердиев А.)	67,4	67,4	77,0	77,0
Итого по объединениям: (s)	88,1	58,3	93,0	70,9

- Key: (a) Total Drilling;
 (b) Of That, Exploratory Drilling;
 (c) Azneft Association;
 (d) Apsheron UBR [Drilling Administration] (Comrades A. Khasmamedov and M. Mamedov);
 (e) Snazanskoye UBR (Comrades A. Gadzhiyev and I. Guvvetov);
 (f) Ali-Bayramli UBR (Comrades N. Alekperov and N. Ismaylov);
 (g) Prikurinskoye UBR (Comrades A. Abasov and T. Kerimov);
 (h) Kyusanginskoye UBR (acting officials Comrades Kh. Dashdamirov and A. Nazirov);
 (i) Dzheyranchelskoye UBR (Comrade Yu. Makhtiyev);
 (j) Dzhharlinskoye UBR (Comrades R. Veliyev and M. Dzhafarov);
 (k) VPO Kasporneftegazprom;
 (l) Neftyanyye Kamni MUBR [M Drilling Administration, full expansion unknown] (Comrades O. Abasov and K. Dadashev);
 (m) Peschanskoye MUBR (Comrades Sh. Mekhtiyev and B. Mamedov);
 (n) Sangachaly MUBR (Comrades S. Magerramov and B. Gadzhiyev);
 (o) Primorskoye MUBR (Comrades A. Ismaylov and M. Kotova);
 (p) Bulla MUBR (Comrades M. Mamedov and V. Akhmedov);
 (q) Bukhta Ilichy MUBR (Comrades A. Gasymov and I. Guseynov);
 (r) MUBR so STS [expansion unknown] (Comrades Ch. Safarov and A. Muradverdiyev);
 (s) Total for Associations.

Drilling, January-October

Baku VYSHKA in Russian 16 Nov 85 p 2

[Article: "How Drilling Is Going"]

[Text] Data from AzSSR Central Statistical Administration on fulfillment (in percentage) of drilling plans of the Azneft Association and the VPO Kasporneftegazprom for January-October 1985.

	Oct		Jan-Oct	
	проходная общая (a)	в т. ч. развед- очная (b)	проходная общая (a)	в т. ч. развед- очная (b)
Объединение «Азнефть» (c)				
(d) Апшеронское УБР (т.т. Хасмамедов А., Мамедов М.)	101,5	77,2	103,4	90,3
(e) Сназанское УБР (т.т. Гаджиев А., Аббасов Б.)	106,2	—	107,7	—
(f) Али-Байрамлинское УБР (т.т. Алекперов Н., Исмаилов Н.)	79,2	1,7	88,6	37,0
(g) Прикуринское УБР (т.т. Абасов А., Керимов Т.)	102,7	113,6	114,4	122,7
(h) Кюрсангинское УБР (и. о. т.т. Дашдамиров Х., Назиров А.)	109,1	109,4	91,7	34,1
(i) Джейранчельское УБР (т.т. Мехтиева Ю., Мустафаев Д.)	100,7	87,1	105,9	165,5
(j) Джарлинское УБР (т.т. Велиев Р., Джафаров М.)	60,1	60,1	88,2	88,2
(j) Джарлинское УБР (т.т. Велиев Р., Джафаров М.)	105,1	105,1	100,9	102,1
ВПО «Каспморнефтегазпром» (k)	92,3	46,3	81,8	55,5
(l) МУБР «Нефтяные Камни» (т.т. Абасов О., Дадашев К.)	134,9	—	100,9	100,4
(m) МУБР «Песчанинское» (т.т. Мехтиева Ш., Мамедов Б.)	148,0	—	96,6	—
(n) МУБР «Сангачальское» (т.т. Магеррамов С., Гаджиев Б.)	85,3	—	81,9	—
(o) МУБР «Приморское» (т.т. Исмаилов А., Котова М.)	100,1	35,4	88,9	70,7
(p) МУБР «Булла» (т.т. Мамедов М., Ахмедов В.)	59,0	59,0	60,9	51,9
(q) МУБР «Бухта Ильича» (т.т. Гасымов А., Гусейнов И.)	122,9	72,9	118,3	88,6
(r) МУБР со СТС (т.т. Сафаров Ч., Мурадвердиев А.)	41,1	41,1	73,4	73,4
Итого по объединениям: (s)	97,0	58,8	93,4	69,7

- Key: (a) Total Drilling;
 (b) Of That, Exploratory Drilling;
 (c) Azneft Association;
 (d) Apsheron UBR [Drilling Administration] (Comrades A. Khasmamedov and M. Mamedov);
 (e) Snazanskoye UBR (Comrades A. Gadzhiyev and I. Guvvetov);
 (f) Ali-Bayramli UBR (Comrades N. Alekperov and N. Ismaylov);
 (g) Prikurinskoye UBR (Comrades A. Abasov and T. Kerimov);
 (h) Kyusanginskoye UBR (acting officials Comrades Kh. Dashdamirov and A. Nazirov);
 (i) Dzheyranchelskoye UBR (Comrade Yu. Makhtiyev);
 (j) Dzharlinskoye UBR (Comrades R. Veliyev and M. Dzhaфарov);
 (k) VPO Kasporneftegazprom;
 (l) Neftyanyye Kamni MUBR [M ___ Drilling Administration, full expansion unknown] (Comrades O. Abasov and K. Dadashev);
 (m) Peschanskoye MUBR (Comrades Sh. Mekhtiyev and B. Mamedov);
 (n) Sangachaly MUBR (Comrades S. Magerramov and B. Gadzhiyev);
 (o) Primorskoye MUBR (Comrades A. Ismaylov and M. Kotova);
 (p) Bulla MUBR (Comrades M. Mamedov and V. Akhmedov);
 (q) Bukhta Ilichy MUBR (Comrades A. Gasymov and I. Guseynov);
 (r) MUBR so STS [expansion unknown] (Comrades Ch. Safarov and A. Muradverdiyev);
 (s) Total for Associations.

Drilling, January–November

Baku VYSHKA in Russian 8 Dec 85 p 1

[Article: "How Drilling Is Going"]

[Text] Data from AzSSR Central Statistical Administration on fulfillment (in percentage) of drilling plans of the Azneft Association and the VPO Kasporneftegazprom for January–November 1985.

		Nov		Jan–Nov	
		проходка общая (a)	в т. ч. развед- очная (b)	проходка общая (a)	в т. ч. развед- очная (b)
Объединение «Азнефть» (c)					
(d)	Апшеронское УБР (т.т. Хасмамедов А., Мамедов М.)	93,6	63,6	102,6	87,5
(e)	Сназанское УБР (т.т. Гаджиев А., Аббасов Б.)	105,2	—	107,5	—
(f)	Али-Байрамлинское УБР (т.т. Алекперов Н., Исмайлв Н.)	39,7	4,1	84,5	33,4
(g)	Прикуринское УБР (т.т. Абасов А., Керимов Т.)	100,4	82,3	113,1	114,8
(h)	Кюрсангинское УБР (т.т. и. о. Дашдамиров Х., Назиров А.)	108,1	—	93,2	30,6
(i)	Джейранчельское УРБ (т.т. Мехтиеv Ю., Мустафаев Д.)	100,2	113,9	105,3	157,1
(j)	Джарлинское УРБ (т.т. Велиев Р., Джафаров М.)	101,0	101,0	89,1	89,1
		49,1	49,1	95,8	96,9
ВПО «Каспморнефтегазпром» (k)		68,0	44,6	80,5	54,5
(l)	МУБР «Нефтяные Камни» (т.т. Абасов О., Дадашев К.)	102,0	—	101,0	100,4
(m)	МУБР «Песчанинское» (т.т. Мехтиеv Ш., Мамедов Б.)	101,2	—	97,1	—
(n)	МУБР «Сангачальское» (т.т. Магеррамов С., Гаджиев Б.)	56,8	—	79,6	—
(o)	МУРБ «Приморское» (т.т. Исмайлв А., Алиев Э.)	77,7	50,2	87,9	68,7
(p)	МУРБ «Булла» (т.т. Мамедов М., Ахмедов В.)	19,9	19,9	57,0	48,8
(q)	МУРБ «Бухта Ильича» (т.т. Гасымов А., Гусейнов И.)	86,1	56,0	115,5	85,9
(r)	МУРБ со СТС (т.т. Сафаров Ч., Мурадвердиев А.)	101,8	101,8	76,2	76,2
Итого по объединениям: (s)		81,4	52,7	92,3	68,0

- Key: (a) Total Drilling;
 (b) Of That, Exploratory Drilling;
 (c) Azneft Association;
 (d) Apsheron UBR [Drilling Administration] (Comrades A. Khasmamedov and M. Mamedov);
 (e) Snazanskoye UBR (Comrades A. Gadzhiyev and I. Guvvetov);
 (f) Ali-Bayramli UBR (Comrades N. Alekperov and N. Ismaylov);
 (g) Prikurinskoye UBR (Comrades A. Abasov and T. Kerimov);
 (h) Kyusanginskoye UBR (acting officials Comrades Kh. Dashdamirov and A. Nazirov);
 (i) Dzhey ranchelskoye UBR (Comrade Yu. Makhtiyev);
 (j) Dzharlinskoye UBR (Comrades R. Veliyev and M. Dzhaфаров);
 (k) VPO Kasporneftegazprom;
 (l) Neftyanyye Kamni MUBR [M___ Drilling Administration, full expansion unknown] (Comrades O. Abasov and K. Dadashev);
 (m) Peschanskoye MUBR (Comrades Sh. Mekhtiyev and B. Mamedov);
 (n) Sangachaly MUBR (Comrades S. Magerramov and B. Gadzhiyev);
 (o) Primorskoye MUBR (Comrades A. Ismaylov and M. Kotova);
 (p) Bulla MUBR (Comrades M. Mamedov and V. Akhmedov);
 (q) Bukhta Ilichа MUBR (Comrades A. Gasymov and I. Guseynov);
 (r) MUBR so STS [expansion unknown] (Comrades Ch. Safarov and A. Muradverdiyev);
 (s) Total for Associations.

Drilling, January-December

Baku VYSHKA in Russian 14 Jan 86 p 1

[Article: "How Drilling Is Going"]

[Text] Data from AzSSR Central Statistical Administration on fulfillment (in percentage) of drilling plans of the Azneft Association and the VPO Kasporneftegazprom for January-December 1985.

	Dec		Jan-Dec	
	(a) проходка общая	(b) в т. ч. развед- очная	(a) проходка общая	(b) в т. ч. развед- очная
Объединение «Азнефть» (с)	74,5	70,1	100,2	85,9
(d) Апшеронское УБР (т.т. Хасмамедов А., Мамедов М.)	63,1	—	103,7	—
(e) Сназанское УБР (т.т. Гаджиев А., Аббасов Б.)	47,3	—	82,0	30,0
(f) Али-Байрамлинское УБР (т.т. Алекперов Н., Исмаилов Н.)	100,3	117,1	111,9	115,2
(g) Прикуринское УБР (т.т. Абасов А., Керимов Т.)	55,8	109,8	90,3	34,7
(h) Кюрсангинское УБР (т.т. и. о. Дашдамиров Х., Назиров А.)	76,2	100,3	102,3	148,5
(i) Джейранчельское УРБ (т.т. Мехтиева Ю., Мустафаев Д.)	53,6	53,6	86,9	86,9
(j) Джарлинское УРБ (т.т. Велиев Р., Джафаров М.)	82,8	82,8	94,6	95,5
ВПО «Каспморнефтегазпром» (к)	68,5	35,4	79,4	52,8
(l) МУБР «Нефтяные Камни» (т.т. Абасов О., Дадашев К.)	102,0	—	101,1	100,4
(m) МУБР «Песчанинское» (т.т. Мехтиева Ш., Мамедов Б.)	131,8	—	100,1	—
(n) МУБР «Сангачальское» (т.т. Маггеррамов С., Гаджиев Б.)	43,8	—	76,6	—
(o) МУРБ «Приморское» (т.т. Исмаилов А., Алиев Э.)	83,1	26,4	87,4	64,9
(p) МУРБ «Булла» (т.т. Мамедов М., Ахмедов В.)	55,4	38,0	56,8	47,9
(q) МУРБ «Бухта Ильича» (т.т. Гасымов А., Гусейнов И.)	79,9	27,0	112,2	81,3
(r) МУРБ со СТС (т.т. Сафаров Ч., Мурадвердиев А.)	34,3	34,3	72,0	72,0
Итого по объединениям: (s)	71,6	50,1	90,5	66,3

- Key: (a) Total Drilling;
 (b) Of That, Exploratory Drilling;
 (c) Azneft Association;
 (d) Apsheron UBR [Drilling Administration] (Comrades A. Khasmamedov and M. Mamedov);
 (e) Snazanskoye UBR (Comrades A. Gadzhiyev and I. Guvvetov);
 (f) Ali-Bayramli UBR (Comrades N. Alekperov and N. Ismaylov);
 (g) Prikurinskoye UBR (Comrades A. Abasov and T. Kerimov);
 (h) Kyusanginskoye UBR (acting officials Comrades Kh. Dashdamirov and A. Nazirov);
 (i) Dzheyranchelskoye UBR (Comrade Yu. Makhtiyev);
 (j) Dzharlinskoye UBR (Comrades R. Veliyev and M. Dzhaфаров);
 (k) VPO Kasporneftegazprom;
 (l) Neftyanyye Kamni MUBR [M_____ Drilling Administration, full expansion unknown] (Comrades O. Abasov and K. Dadashev);
 (m) Peschanskoye MUBR (Comrades Sh. Mekhtiyev and B. Mamedov);
 (n) Sangachaly MUBR (Comrades S. Magerramov and B. Gadzhiyev);
 (o) Primorskoye MUBR (Comrades A. Ismaylov and M. Kotova);
 (p) Bulla MUBR (Comrades M. Mamedov and V. Akhmedov);
 (q) Bukhta Ilicha MUBR (Comrades A. Gasymov and I. Guseynov);
 (r) MUBR so STS [expansion unknown] (Comrades Ch. Safarov and A. Muradverdiyev);
 (s) Total for Associations.

11176

CSO: 1822/183

OIL AND GAS

UDC553.982:550.812

ASSIMILATING OIL RESOURCES OF WESTERN SIBERIA

Moscow GEOLOGIYA NEFTI I GAZA in Russian No 10, Oct 85, pp 6-13

[Article by F.K. Salmanov, Main Administration for Geology of Tyumen, I.I. Nesterov, N.K. Kulakhmetov, and V.I. Shpilman, ZapSibNIGNI and A.V. Tyan, ZapSibMVTK]

[Abstract] A discussion is presented of the optimal relationship of reserves accounted in the balance of prospecting and producing enterprises, an effective system of transfer of resources from balance to balance and for their accounting by the State Commission on Reserves of Useful Minerals of the USSR, the effective relationship of volumes of search and prospecting operations and categories of reserves in the balance of prospecting organizations. In the mature stage of assimilation of a region, the most important parameter determining the relationship between categories of reserves is the maximum fraction of annual transfer of categories, which decreases due to the natural deterioration in structure of the reserves as an area is assimilated. The most important parameters defining the annual preparation of reserves by prospecting organizations is production, its annual rate of increase and the assurance of stable output. The distribution of study operations between prospecting and production organizations is discussed. Equations are presented which can increase the effectiveness of the operation of energy complexes in large production regions.

6508/12948
CSO: 1822/149

OIL AND GAS

UDC621.643/553.002.2+62.001.7

SCIENTIFIC, TECHNOLOGICAL PROGRESS IN OIL, GAS CONSTRUCTION

Moscow STROITELSTVO TRUBOPROVODOV in Russian No 10, Oct 85 pp 2-8

[Unsigned article: "Reserves for Acceleration of Scientific and Technical Progress in The Sector"]

[Summary] A meeting was held of activists of the Ministry of Petroleum and Gas Construction, dedicated to accelerating scientific and technical progress in the construction of petroleum and gas industry projects. Responsible workers of the Party Central Committee, USSR Council of Ministers, State Construction Commission, Committee on Science and Technology, People's Control Committee and other organizations took part. B.Ye. Shcherbin, Deputy Chairman, USSR Council of Ministers, also attended. The Minister for Construction of Petroleum and Gas Industry Enterprises, V.G. Chirskov, discussed the major problems related to acceleration of the introduction of achievements of scientific and technical progress in the industry. These include:

Industrialization of surface construction beyond the 62 percent level of industrialization, which does not meet the requirements of today;

Utilization of modular construction, which can halve the time required to complete construction projects;

Use of manufactured buildings and temporary housing and public structures of more progressive design, such as the VZHK-50 residential complex produced at Oktyabrskiy Plant, decreasing the consumption of rolled metal products per square meter of housing area by 16 percent, and the use of large-panel construction techniques, decreasing cost by 10 percent, labor consumption by 30 percent, and construction time by a factor of 1.5-2.

Production of more effective structural and insulating materials, pipes and fasteners such as superfine basalt fiber as nonflammable insulation to be used in permafrost, azarite gravel and silipore insulation, new and progressive insulating materials for corrosion protection of hot spots on the pipelines. Experiments in 1985 showed the possibility of construction of 1420 mm diameter spiral-seam pipe, wall thickness 15.1 cm, strength 650 MPa;

Development of industrial enterprises, which are important in supplying organizations with materials and structure, machines and mechanisms, as well as repair services, eliminating present shortcomings, further utilizing production facilities and increasing production and technological discipline, particularly in the main administration for oil and gas industry construction and main administration for pipe construction. Certification of work places alone could decrease the expenditure of labor by 5-10 percent;

Improvement of line construction, including welding operations, reequipping welding organizations by broadly using electric contact welding of 57 to 1420 mm diameter pipes, introducing powdered welding wire and welding under flux, replacing manual welding with automatic welding, creating mechanized production for assembly and automatic welding of structures to increase the productivity of labor;

Insulation and ballasting of pipes using polyethylene or epoxy compounds applied automatically at manufacturing plants;

Improving construction in the north on a year-round basis under permafrost conditions by the use of highly mechanized systems equipped with effective swamp-crossing equipment;

Continuation of scientific research, design and planning work on the creation of major pipeline systems for hydrotransport of coal, ore concentrates and mineral fertilizer raw materials;

Improvement of the quality of work, the level of mechanization and the utilization of motorized transport equipment to improve the quality of production, reducing problems with welding and installation work and decreasing the rate of defective production by construction industry enterprises. This will require basic and decisive steps, a restructuring of all operations to be sure that the quality assurance steps meet today's requirements;

Reduction in the quantity of manual labor, which has decreased by 6.2 percent since 1980, but is still too high, particularly in general construction operations (62.1 percent) and line construction (30.3 percent). A reduction in manual labor by 1 percent is equivalent to liberation of 1800 workers. A special combined program for 1986-1990 and beyond is under development for this purpose. Improvement of the utilization of the available pool of construction machinery must be achieved, to allow this equipment to produce 15 to 18 percent more work;

Improvement of the activity of scientific research and design organizations, including improvement of the structure of these organizations, with the opening of two new institutes. The training of scientific personnel should be improved, increasing the demands placed on scientific advisors supervising graduate students;

Increasing emphasis on rationalizers and inventors by increasing the demands on scientific level of developments and suggestions, emphasizing patent research and coordinating the development of a range of problems relating

to technology, economics, organization and administration. Basic restructuring of the administration of scientific and technical progress is required, with the development of new forms of interaction of science with production;

Improvement in the structure of administration and economic mechanisms, including improvement of administration, the organizational structure, and the entire economic mechanism. A program for further development of the economic mechanism over the next 5 year plan is required, intended to achieve comprehensive development of economic initiative, and socialist responsibility, expanding the rights and increasing the responsibilities of organizations and enterprises, introducing full independent accounting;

Improvement of plans and estimates to reduce time and cost and, most importantly, the consumption of materials and labor on construction projects. One or two institutes in the industry should be set up to provide paid consultation on a self-financing basis, involving the most experienced specialists in the industry;

Use of team forms of organization of production, a reliable tool for activation of internal production reserves;

Use of the expedition-watch form of organization of labor to intensify construction. This and other social reserves for development of promising forms of organization of labor is under valued by many executives.

A major task is reeducation of personnel from top to bottom, concentrating their attention on the most important thing, scientific and technical progress. Introduction of new equipment and leading technology is impossible without increasing the qualifications of workers. Acceleration of scientific and technical progress requires constant continuing education of specialists and administrators at all levels. The organization, economic and social factors must be mobilized, order instilled, responsibility and discipline strengthened, the organization of production and labor improved and work with young people mobilized to allow better utilization of the resources in the industry.

6508/12948
CSO: 1822/149

NUCLEAR POWER

PLANS FOR GEORGIAN NUCLEAR POWERPLANT

Tbilisi KOMUNISTI in Georgian 27 Nov 85 p 3

[Editorial Report] Tbilisi KOMUNISTI in Georgian on 27 November 1985 carries on page 3 under the current rubric "Discussing Documents Prior to the Party Congress" Gruzinform correspondents R. Davydov's and A. Shartunov's 900-word piece consisting of interviews with two republic electrical power system officials concerning the nuclear power plant that is to be built somewhere in Georgia, in accordance with a relevant passage from the draft 12th Five-Year Plan, which is quoted in the introduction to the piece.

The first official, Zurab V. Mindeli, is identified as "Khudoni GES Deputy Director for Construction of the Georgian Nuclear Power Plant" [zamestitel Khudonskoy GES po chasty stroyki Gruzinskoy AES], an admittedly "strange" title which he explains by saying that the management of the future plant is only just beginning to be formed, as indeed the actual lines of work are only beginning to be mapped. The contractor for the project is Soyuzatomenergostroy (headed by S. Tsvirko), and plans [proyekt] were drawn up by the Rostov Department of the Termoelektroproyekt Institute. Fast-neutron reactors are to be provided by the Volga-Don Atommash Plant. A number of Georgian outfits and institutes are also listed as participating in the project, mainly those having to do with geology and seismostability.

Planners checked out over 30 sites for the future plant and finally settled on the one (unnamed in this piece) which would best "guarantee" the least soil subsidence. Work will begin in the second half of 1986. Phase 1 is to go operational in 1994, Phase 2 in 1996. Plans call for further expansion to double capacity.

Mindeli then addresses "the fears of some people" that such plants are dangerous. He points out that international AES experience has demonstrated superior safety as well as less ecological damage. There are plenty of back-up systems built in. Finally, the all-union Atomenergoadzor is responsible for ensuring trouble-free operation.

The second energy official, Gruzglavenergo Chief I. Chedia, focuses mainly on Georgia's growing industrial potential as the reason why the AES must be built. The present reliance on hydropower cannot meet those needs.

ENERGY CONSERVATION

NATURAL GAS CONSUMPTION, SAFETY IN ARMENIAN SSR

Yerevan KOMMUNIST in Russian 14 Nov 85 p 2

[Article by B. Beglaryan, chief, republic gas engineering communal inspection service: "A Responsible Attitude Toward Gas Consumption"]

[Text] From year to year the amount of gas which we consume in the republic is increasing. Today the blue fuel is being distributed in 57 cities and city-type settlements and in thousands of villages. More than 2,000 industrial enterprises, boiler houses and communal and general services facilities are being serviced. More than 600,000 apartments are supplied with natural and compressed gas.

At the same time, the increased volume of gas consumption places at the forefront questions concerning its safe and effective use. Existing shortages are especially noticeable with the onset of cold winter weather. At this time, naturally, the amount of gas consumed greatly increases. This destabilizes the pressure systems in the gas pipelines and creates large pressure fluctuations on different days and at different times of day, which in turn causes the equipment at gas regulating points to go out of order. In the language of gas workers this is called "emergency working conditions," under which breakdowns and accidents are possible, especially in gas supplied residential housing.

For example, fires broke out simultaneously in five residences from the strong pressure fluctuation in gas pipelines in Stepanavan a few years ago, which did significant damage to the proprietors of these houses. In January 1984 an explosion took place in a five story house in Abovyan, from which five people suffered and damages amounted to approximately 110,000 rubles.

These accidents and, most importantly, the "emergency working conditions," could be eliminated if many gas consuming enterprises had a more thoughtful attitude toward this matter. A number of ministries, departments and ispolkoms of city and rayon soviets do not concern themselves in a timely manner about obtaining limits on gas based on their needs. As a result, the amount of gas planned for delivery to them is substantially less than their needs. This applies to enterprises in the ministries of industrial construction, agriculture, fruit and vegetable farming, the food industry, and several others. The same picture is also observed with regards to communal

and general services consumers in the Idzhevanskiy, Echmiadzinskiy, Oktemberyanskiy, Abovyanskiy and other rayons.

I would also like to discuss one other important factor. During sharp cold snaps, complete or partial limits on gas consumption by industrial and agricultural enterprises are imposed by the republic fuel commission, to maintain gas supply to the population. However, discipline in fulfilling the limitation is at a low level with respect to some enterprises. In the best case the limitation is placed in operation several hours after it is imposed. Some managers break the seal placed by gas company workers. G. Tonoyan, general director of the Sovetashen PTO [probably technical service point]; N. Kazumov, director of the Yerevan Champagne Factory; A. Gevorkyan, director of the Yerevan Combine for Large Panel Housing Construction and others "distinguish themselves" in this way.

Efforts to develop plants with a reserve fuel type, which the managers of many enterprises have left in an unsatisfactory state, are directly associated with these same questions.

This attitude not only hampers the smooth supply of consumers with gas and causes great inconvenience for gas plant workers, but it also creates a direct threat to the safety of the population.

Damage to underground gas pipelines, committed mainly by construction organizations through violating the rules for earth moving operations, inflict great harm. Gas leaks form from the places of damage, which can not always be detected in a timely manner. Gas can spread underground and along water pipe trenches, sewer systems, heat lines and other supply lines and penetrate into the basements of residential housing and industrial buildings, with very unhappy consequences.

This year in Yerevan alone there were five cases reported of damage to gas pipelines during earth moving work. The Gorteplosetstroy Construction Administration, twice in close succession, damaged a gas pipeline -- near the Republic Stadium and along Dzhaparidze Street. Yergorsovet SRSU [expansion not found] knocked out the gas pipeline along Vardashena Street. The builders left the place of the accident without sounding a warning, which indicates their low sense of responsibility. In such cases it is necessary to apply the most severe measures of liability provided for by law.

The Housing Operating Administration must organize work to seal the points where engineer supply lines enter the basements of buildings, as well as to clean out and provide free access to them for gas plant workers, for periodic preventative inspections of their gas levels.

The intelligent use of gas by housewives themselves in their apartments is also important for ensuring safety and economical use. Every unnecessary minute that a gas burner is on; uneconomical use of hot water; and careless attitude toward preserving heat in the apartment leads, in the final analysis, to a large overexpenditure of gas.

Since 1 October the republic has been carrying out a two month campaign for safe use of gas in everyday life. Preliminary data indicates that users in some rayons still do not know and are not able to employ safe and prudent techniques for the use of gas. Cases are even being disclosed in which quarters were heated with gas ranges, which is not only inefficient, but also threatens carbon monoxide poisoning. Even worse violations of safety regulations are committed in gas plants, which lead to tragic consequences.

Many residents, ignoring elementary rules of safety, connect gas to ordinary wooden stoves to heat their quarters. Thus, workers at the gas plant in the settlement of Noyemberyan twice removed a rubber hose used to connect gas to a stove belonging to E. Khachikyan. However, the warning had no effect and the sad result was that an explosion occurred and family members received serious burns.

On the threshold of winter, which is the greatest test of the reliability of the republic's gas supply system, I wish to appeal again to all the managers of gas plants; enterprise managers responsible for gas plants; ZhEU [housing operation administrations] and the population to take an active part in the struggle to save gas and to develop widespread explanatory work among the collectives on the need to use gas efficiently and prudently, and to observe all rules and techniques for safe gas consumption. Enterprises are obligated to create reserve fuel supplies and to ensure, when necessary, the rapid transfer of boiler room assemblies to their use.

A proprietary approach to the expenditure of gas is, in the final analysis, the guarantee of a normal and safe gas supply for our cities and villages.

9069

CSO: 1822/204

ENERGY CONSERVATION

LENINGRAD NEEDS MORE CHALLENGING ENERGY CONSERVATION PROGRAM

Leningrad LENINGRADSKAYA PRAVDA in Russian 12 Jan 86 p 1

[Article by P. Sivko, director, Northwestern Department, VNIPIenergoprom [All-Union Scientific Research and Designing Institute of the Energy Industry], chairman, Coordination Council for the Regional Specific-Purpose "Energy" Program: "Following the 'Energy' Program"]

[Text] These are the days of formation of the plans for economizing on fuel and energy in 1986: Enterprises, associations and entire rayons are adopting socialist pledges within the framework of a new regional "Energy" program. Analyzing these plans and meeting with their developers, each time one invariably asks the same question. What has changed in the attitude of people toward economizing on energy resources, and do they all understand how much the importance of work in this direction is growing? Frankly speaking, grounds for optimism do not appear all that often.

Here is an example. An inspection of progress in satisfying pledges at enterprises of Krasnogvardeyskiy, Kalininskiy, Zhdanovskiyy and Vyborgskiy rayons showed that many of the labor collectives have planned the most minimal targets for economization on fuel and energy. What is the explanation for this? As a rule, executives point to one circumstance as an excuse: Most of the slack had already been taken up in the course of fulfilling the quotas of the first "Energy" program. Let us see how plausible such an explanation is.

Yes, as would have been expected from the initiators of creating the country's first specific-purpose regional "Energy" program, the citizens of Leningrad honorably worked on its implementation. In the years of the past five-year plan the planning indicators concerned with economizing on energy resources were surpassed by almost 20 percent. The result was substantial: The Izhorskiy Zavod Association, an industrial giant, could work for 7 years on the fuel and energy that had been saved!

There are also other results which in my opinion have to do not so much with the previous as with the new stage in the struggle for economy. During implementation of the "Energy" program the power management administrations of more than a hundred large industrial enterprises were examined, the energy use logs of dozens of others were analyzed, and in Leningrad and in the oblast as a whole, the basic paths of economizing on resources in all energy-intensive industrial sectors were revealed. This became a unique

sort of foundation for development of the "Energy" program for the new five-year plan which, incidentally, has become a most important component of the integrated "Intensification-90" program.

As we can see, much effort has been applied to fulfill the energy resource economization quotas, but this does not at all mean that all of the reserves have been exhausted. This can be said only of those reserves which lay on the surface. Now the question is being posed more incisively and fundamentally: Besides the relatively simple methods of economizing on energy, we need to utilize the deep reserves associated with introducing energy-conserving production procedures. The need for such reorganization is obvious.

As is stated in the draft Basic Directions, by the year 2000 75-80 percent of the increment in the demand for fuel, energy, raw materials and materials must be satisfied through economization. Challenging energy resource economization targets have also been planned for the present five-year plan. In Leningrad and in the oblast, energy outlays per ruble of production must be reduced by more than 7 percent in comparison with 1985, and energy outlays must grow by only 0.6 percent for every percent growth in the volume of commercial production. Is it not obvious how important it is to plan concrete measures insuring attainment of these control figures right now?

Among the problems associated with sensible use of fuel and energy, that of economizing on so-called secondary energy resources is a special one. By raising the degree of their utilization we can quickly and economically reduce the maximum demands of the enterprises for fuel and energy. I have no doubt that many businessmen know this, but.... At the moment secondary energy resources are being utilized in our region to only 23 percent of what is possible.

But on the other hand collectives such as the Svetogorsk Pulp and Paper Combine, the Svetlana and Podyemtransmash associations, the Krasnyy Khimik Plant and a number of others did manage to attain substantial results in economizing on secondary energy resources. Special mention should be made of the experience of the Volkhov Aluminum Plant which, as we know, enjoyed the approval of the CPSU Central Committee.

What is keeping this progressive experience from spreading to other enterprises of Leningrad and the oblast? For the sake of justice it must be said that besides subjective reasons, there are a large number of rather complex general problems, solution of which is not always within the means of the individual collective. Let me name just a few. Thus far, the overwhelming number of the enterprises are still lacking information on sector procedures for calculating the volumes of secondary energy resources produced and their possible utilization, and they do not possess instruments with which to account for them. But perhaps the most serious problem is the absence of special recycling equipment, chiefly equipment of low productivity, which is not being manufactured at all either by the Ministry of Power Machine Building or by other ministries.

It seems to me that the list itself of the problems attests to the fact that they must be solved on an intersector basis. But the sector institutes of various ministries are not displaying any interest in these problems for the moment. The problem is that the ministries are not developing plans for reconstruction of power management administrations and introduction of energy conserving production procedures into the enterprises of the region in coordination with intersector problems.

The section "Fuel and Energy Complex" of the draft Basic Directions of the USSR's Economic and Social Development states the need for consistent implementation of a purposeful energy conservation policy in all sectors and spheres of the national economy. I think that it makes sense to supplement this section with the following words: "Raise the effectiveness of regional programs for economization of fuel and energy resources on the basis of intersector cooperation and specialization."

There is another problem which must be solved before any kind of reorganization would be possible in energy conservation policy. We refer more and more frequently to the growing role of the human factor in all spheres of life. Great also is its role in economization. However, this reserve is not being utilized adequately yet.

The work experience of the past five-year plan showed that a thrifty attitude toward energy resources has not yet been adequately reflected in the present terms of the socialist competition.

Nor can we ever condone the fact that people at many enterprises fight for thrift in their words but implement economization measures only in formal terms and assess their results in the old ways.

New efforts must be made to raise the interest of both the collectives and individual workers in intensifying economization of energy resources. I would like to make one more proposal in this connection. The draft Basic Directions foresee a significant increase in the role of economic levers in raising the effectiveness of production and promoting economization. I feel that these same goals must also become paramount in organizing socialist competition. Therefore I propose adding the following to the section "Improvement of Control Over the National Economy" after the words "Improve the forms and organization of socialist competition, directed at attaining high work results": "through maximum utilization of existing reserves and the strictest possible economization."

11004

CSO: 1822/167A

ENERGY CONSERVATION

SURVEY OF FUEL, POWER CONSUMPTION PROBLEMS

Moscow EKONOMICHESKAYA GAZETA in Russian No 6, Feb 86 pp 1-2

[Article by S. Yatrov, director of the All-Union Research Institute for the Study of Complex Fuel and Energy Problems, and V. Chebotarev, laboratory chief, under the rubric "Economic Overview": "Power Consumption by Production"; capitalized passages published in boldface]

[Text] First of all, a few statistics. In 1960 the USSR's consumption of electric power by industry was equal to 46 percent that of the United States. In 1970 this figure was 69 percent, and in 1983 -- 96 percent. But the amounts of goods produced by Soviet industry as compared to United States industry for the same years were as follows: more than 55 percent, more than 75 percent and more than 80 percent. In other words, whereas previously we expended less electric power per unit of industrial goods produced than did the United States, now we expend more. What do these figures tell us? On the one hand, undoubtedly, they bespeak the great strides forward in the electrification of industrial production in the USSR. On the other, they indicate the existence of differences in the structure of consumption of fuel and energy resources in the two countries. But do they not also indicate inefficient utilization of electric power in our industry? Unfortunately they do.

A Very Acute and Current Problem

This was the way M. S. Gorbachev referred to the problem of how to utilize and conserve resources, speaking before an assembly of the aktiv of the Leningrad party organization in May 1985. At present our country expends considerably more raw materials, energy and other resources per unit of national income than do a number of other countries.

The figures given above present only one aspect of the issue: consumption of electric power by industry. In order to estimate total wasteful or, as the case may be, efficient utilization of fuel and energy, we must employ a generalized index. This is referred to as ENERGY CONSUMPTION BY PUBLIC

PRODUCTION. Tasks based upon this index were included for the first time in the draft of the Basic Directions for the 12th Five-Year Plan and the period up to the year 2000.

What does this index represent?

Energy consumption by public production expresses the relationship between all fuel and energy resources (heating fuel, petroleum products, electric power and thermal energy), expressed in metric tons of standard fuel, used in the course of a year and the volume of national income produced. In other words THE ECONOMIC SIGNIFICANCE OF THIS INDEX LIES IN ITS COMPARISON OF FUEL AND ENERGY RESOURCES EXPENDED WITH THE END RESULTS OF PUBLIC PRODUCTION.

Dynamics and Structure

Reduction of energy consumption has a tremendous influence on all aspects of public production. At the level of the entire national economy, efficient utilization of fuel and energy resources leads to changes in the structure of their consumption: expenditure of fuel and energy resources per unit of goods produced is reduced; the proportion of resources used as raw material and for other non-fuel needs increases; and the percentage of fuel and energy resources allocated for the public's consumer needs increases.

Consequently the rate of reduction of energy consumption by public production becomes one of the most important indices which characterize the speeding up of technical progress.

Over the past five years the rate of reduction of energy consumption per unit of national income produced has increased. Whereas during the 10th Five-Year Plan this rate of reduction averaged one percent per year, during the 1981-1984 period it was 1.4 percent. Reduction of energy consumption by production is proceeding at an even faster rate at many advanced industrial enterprises.

* * * * *

Conservation of Boiler and Furnace Fuel, Electricity and Thermal Energy Through Reduction of Proportional Expenditures (as compared to 1980)

	1981	1982	1983	1984
Boiler and furnace fuel, expressed as millions of tons of standard fuel.....	6.5	12.5	19.5	31.4
Electricity, in billions of kilowatt-hours.....	5.8	11.8	27.5	42.9
Thermal energy, in millions of gigacalories.....	23.5	62.6	96.6	89.2

* * * * *

However, we are lagging behind many socialist and capitalist countries in terms of rates of reduction of energy consumption by production and the scale

of our fuel and energy resource conservation efforts. And unless we find a solution to this problem we will not be able to ensure thorough intensification of production and the transition to a resource-conserving path of development. Present rates of reduction of energy consumption per unit of national income produced obviously fall short of the possibilities presented by scientific and technical progress.

In 1984, expenditure of boiler and furnace fuel in excess of established limits was recorded at one-seventh of all enterprises under the USSR Ministry of Power and Electrification, one-tenth of those under the USSR Ministry of Ferrous Metallurgy and one-fifth of those under the Ministry of Mineral Fertilizer Production. This negative picture is due not only to insufficient attention to implementation of planned measures designed to conserve energy resources, but also to disregard for the most elementary guidelines for the storage, transport and utilization of fuel resources. This latter reason is all the more inadmissible in light of the fact that these ministries produce the most energy-intensive products and account for over 50 percent of all the fuel used in our entire country.

Means of Reduction

During the 12th Five-Year Plan work to reduce energy consumption by public production must be raised to a new level. Planned are a reduction of energy consumption per unit of national income produced by seven to nine percent and a savings of 200-230 million tons (standard fuel) of organic fuel throughout the national economy as a whole, including 75-90 million tons to be conserved through the development of nuclear energy. By the year 2000 it is planned that energy consumption per unit of national income will be reduced by a factor of not less than 1.4. ATTAINMENT OF THESE AMBITIOUS GOALS IS POSSIBLE ONLY THROUGH MAXIMUM UTILIZATION OF SCIENTIFIC AND TECHNICAL ADVANCES.

Improvement of technical processes and of the structure of goods produced is a highly important means of reducing energy consumption by production in such energy-intensive sectors as the building materials industry, power engineering, ferrous and nonferrous metallurgy and the chemical and petrochemical industries, which use over 70 percent of all the fuel and energy consumed in this country.

Thus, simply reducing to the national average the amount of fuel used to produce one kilowatt-hour of electricity at all thermal electric power plants would result in savings of 20-22 million tons of fuel annually, and approximately 100 million tons during the span of the five-year plan. Each year up to eight million metric tons of gasoline are expended unnecessarily due to lags in the transition of motor pools to diesel engines.

In almost all industries new, progressive and less energy-intensive technologies have appeared alongside the traditional technologies currently in use. In nonferrous metallurgy a substantial reduction in energy consumption is being brought about by the introduction of oxygen-conversion and electrical methods in place of the open-hearth method of steel production. Transition

from a "wet" to a "dry" system for the production of cement klinker in the building materials industries is making possible a 30 percent reduction in fuel consumption.

In the machine building industry, consumption of fuel and energy is decreasing by from 20 to 50 percent in various production processes; this is being achieved by transition to more progressive forms of metalworking (e.g. stamping, welding, precision casting and electronic technology).

A considerable reduction of consumption of crude fuel is being achieved through utilization of secondary fuel and heat resources, including heat recovered from the ventilation of industrial buildings.

A considerable savings of fuel resources can be achieved by making efficient use of all the energy capacities of each enterprise, of mechanical engines and equipment, electric motors, electric apparatuses, internal combustion engines, compressors and transformers.

In agriculture, reduction of energy consumption in production will be made possible by the envisioned improvement of the structure of machines and tools in accordance with the planned 1986-1990 list of machine systems for the mechanization of agricultural jobs and increase of their productivity by a factor of 1.5-1.8. This will also be effected by an increase by a factor of three in the production of parts for high-powered tractors and introduction of the Agrovent system at livestock breeding farms. This system was developed jointly by Finnish and Soviet specialists, and can provide up to 87 percent savings of fuel used for heating purposes. Steps taken to make heating, lighting and water supply for municipal and domestic purposes more efficient are highly effective. Up to one-third of all the heat energy created in our country goes for heat and year-round hot water supply in apartment houses, and over 100 billion kilowatt-hours of electricity are expended to meet the household needs of the public each year.

Economic Levers

In connection with the new tasks in the field of resource conservation this analytical index, which is currently only being used at the level of the national economy and its branches, MUST BE TRANSFORMED INTO AN INDEX USED IN PLANNING BY ALL THE MINISTRIES AND PRODUCTION ASSOCIATIONS IN THE PHYSICAL PRODUCTION SECTOR. THE EXISTING SYSTEM OF ACCOUNTING AND ACCOUNTABILITY MAKES IT POSSIBLE TO APPLY THIS INDEX TO ALL LEVELS OF ADMINISTRATION OF THE ECONOMY WITHOUT ANY ADDITIONAL EXPENSE.

Utilization of the instruments of planning in the implementation of an energy conservation policy today consists of definition of tasks aimed at tightening of the standards for fuel and energy consumption by the most energy-intensive production processes and jobs. Under the current system standards are set separately for each type of energy resource, i.e. the consumption of fuel or heat from fuel and electric power is planned separately for each type of item produced.

During the 11th Five-Year Plan the volume of energy resources subject to standardization increased significantly as compared to the 10th Five-Year Plan. Today almost all consumption of boiler and furnace fuel, 60 percent of electricity and 50 percent of heat energy are calculated according to consumption norms.

However, the present system of standardization of fuel and energy resource consumption has serious flaws, and in some cases it conflicts with highly important trends in scientific and technical progress.

Firstly, only the most fuel-, heat- and electricity-intensive production processes and jobs are subject to standardization, and only direct use of fuel, heat or electricity is standardized, not total energy consumption. And if, for example, standards for fuel consumption are tightened, but overexpenditure of electricity or heat is permitted, then it becomes difficult to evaluate fulfillment of plan goals according to standard criteria.

Secondly, it is impossible to standardize consumption of fuel and energy resources for all types of production. Thus, in the state plan for 1985 the Ministry of the Building Material Industry was given over 100 tasks and indices pertaining to conservation of boiler and furnace fuel and thermal and electric energy. The system for calculating goals and indices pertaining to conservation is becoming unjustifiably cumbersome. The list of standards lacks criteria for measuring the efficiency of utilization of fuel and energy resources. Such a system limits the administrative independence of the ministry and its enterprises. Development of goals for ministries in connection with conservation of fuel and energy according to type of production and technical process does not help increase the level of their employees' responsibility for the implementation of an energy conservation policy.

Monitoring of goal fulfillment and accounting in this area are extremely problematic, since instrument monitoring can be set up only for electric power, and even in that case not for all processes. As for other types of calculation of fuel and energy consumption, the methods of monitoring and regulation are at this point obviously inadequate.

Thirdly, the existing system for standardization of fuel and energy resources and for targeted average rates of reduction in consumption are not always tied in with those indices which measure the increase of production efficiency. The standards do not reflect advances in the structure and variety of goods produced, changes in their quality and other factors which will have the greatest effect on energy consumption in production in the period of acceleration of scientific and technical progress. A standard for consumption of energy resources set strictly on a single, albeit principal form of production, sometimes impedes the introduction of complex processing technologies for produced basic raw materials.

How can we make the system of standardization truly work for scientific and technical progress and energy conservation?

In order to increase the efficiency of utilization of fuel and energy resource and to increase interest in achieving this on the part of not just enterprises, but the apparatus as well, WE MUST MAKE A TRANSITION TO PLANNED RATES OF REDUCTION IN ENERGY CONSUMPTION BY PRODUCTION AND, WHERE NECESSARY, TO QUOTAS ON FUEL CONSUMPTION, HEAT CONSUMPTION AND ELECTRICITY CONSUMPTION IN PRODUCTION. These indices, together with consumption standards and goals for the average reduction thereof (for a limited products list) will make it possible to encompass all fuel and energy resources with planning, will make possible a deeper analysis of the functioning of industries, and will encourage all workers to seek out untapped resources and to actively introduce scientific and technical advances into production.

It is extremely important that we take steps to increase the degree of responsibility for nonfulfillment of goals pertaining to conservation of fuel and energy and to increase material incentives to workers to conserve fuel and energy resources.

During the 11th Five-Year Plan a number of resolutions pertaining to energy conservation and the awarding of prizes for energy conservation were adopted. However, swift practical application of these resolutions was hindered by the absence of instructions on how to implement them, completion of which instructions was held up for a long while by employees of the USSR State Committee for Labor and Social Problems and the USSR Ministry of Finances.

The effectiveness of measures to conserve energy depend in large part on the state of power facilities in all sectors of our economy and at individual enterprises. In the GDR, for example, successful fulfillment of plans to conserve fuel and energy resources is to a large degree explainable by the fact that responsibility for the state of power facilities and for adherence to standards governing the consumption of fuel and electricity falls directly upon the directors of combines.

Under the conditions existing in our country it would probably also make sense to place all the responsibility for implementation of energy-saving measures and for the state of affairs with regard to conservation on the administrators of enterprises, associations and ministries. In our opinion, the measures proposed above will guarantee fulfillment of plan goals pertaining to conservation of fuel and energy resources.

12825
CSO: 1822/194

MILD WINTER, NEW POWER PLANTS HELP SATISFY DEMAND

Moscow EKONOMICHESKAYA GAZETA in Russian No 6, Feb 86 p 4

[Article by A. Nikolayev: "Electric Power"]

[Text] The enterprises under the USSR Ministry of Power and Electrification entered the period of maximum winter power usage in a more organized fashion than last year. The number of outages and brownouts in the supply of electric power consumers decreased, the frequency of current in power systems rose to the standard level, and the supply of heat for industry and the public became more reliable. This was the result of more careful preparations for winter conditions not only at electric power plants, but also at enterprises; the latter began to use electric and heat energy more economically.

The first half of January 1986 was an average of five degrees Celsius warmer than the same period last year. Therefore, the amount of electric power generated had to be increased only by an insignificant amount. For that half of the month total power generated was 66.2 billion kilowatt-hours, as opposed to 65 billion kilowatt-hours for the same period last year.

There are two other important features of the operations of energy-producing enterprises this winter. Firstly, high-quality and timely renovation of power plant equipment and preparations for winter conditions made possible a substantial increase in the coefficient of efficiency for utilization of electric power plants' existing capacity. During the first 15 days of January this coefficient was 82.1 percent, and 94 percent for nuclear electric power plants. Units with a total capacity of 11 million kilowatts were undergoing various types of renovation during the period. The previous winter the coefficient of utilization of existing capacity was 79.3 percent, and units with a total capacity of almost 14 million kilowatts were under repair and therefore out of service at that time.

Secondly, newly installed power units helped cover maximum load periods to a considerably greater degree than last winter. During 1985 a total of 11.6 million kilowatts of new energy capacities were put into production, which was more than in 1984 by a factor of 1.3. New power units with a capacity of approximately seven million kilowatts immediately went on line and became reliable parts of the system within minimal shakedown periods. Among these one should note the Smolenskaya, Zaporozhskaya and Balakovskaya nuclear electric power plants, the Sayano-Sushenskaya, Maynskaya, Baypazinskaya,

Tashkumyrskaya and Miatlinskaya hydroelectric power plants, the Surgut State Regional Electric Power Plant [GRES] #2, and the Azerbaijanskaya and Mariyskaya thermal electric power plants. Stabilization of operations at Ekibastuz GRES #1 had a positive effect on power supplies in North Kazakhstan and the Urals; for the first time this station produced 3.5 to 3.8 million kilowatts.

Nevertheless, results could have been better if it had been possible to complete construction of such important projects as the Permskaya and Berezovskaya GRES's, the Zagorskaya [GAES] and the Tyumenskaya and Biyskaya heat and electric power plants. Lags in the construction of power networks made it impossible to use major power units at a number of electric power plants, including some nuclear plants, to their full capacity.

At the beginning of the year the unsatisfactory condition of rural electric networks was the reason for massive breakdowns in the wake of ice storms and strong winds. The USSR Ministry of Power and Electrification is taking steps to eliminate the shortcomings mentioned above.

12825

CSO: 1822/194

ENERGY CONSERVATION

BRIEFS

MOSCOW NATURAL GAS CONSUMPTION -- Workers at the Mosgaz Order of Labor Red Banner Production Association are making an important contribution to the social and economic development of Moscow. For its workers the 11th Five-Year Plan was a period of further increasing the supply of gas to capital consumers; improving production and operation activity; increasing all types of services provided to the population and solving a great number of social problems. Thus, during the five-year plan gas supply increased by 6 billion cubic meters, and by 1990 will reach 30 billion; i.e., will grow 1.6 fold. At the end of last year income from the sale of gas was 613 million rubles in comparable prices, and the growth rate was 130 percent. This rate is also being retained during the 12th Five-Year Plan. Profits from the sale of gas were 86 million rubles in 1985, and by 1990 it is planned that they will reach 107 million rubles. The past period was characterized by an increase in the amount of communal services per worker. Its rates were 132 percent by the start of the 12th Five-Year Plan. [by N. P. Kononchuk, general director, Mosgaz Production Association] [Excerpt] [Moscow ZHILISHCHNOYE I KOMMUNALNOYE KHOZYAYSTVO in Russian No 1, Jan 86 p 19] [COPYRIGHT: Stroyizdat, 1986] 9069

HIDDEN FUEL COSTS--Reduction of the mass of structural members has not only technical but also enormous economic significance, especially in the present stage. Recall that each year over 70 million tons of standard fuel units are expended to produce construction materials and articles, and even more--400 million tons--are expended to heat buildings. [By Yu. Mikhaylov][Excerpt] [Moscow EKONOMICHESKAYA GAZETA in Russian No 50, Dec 85 p 12] 11004

CSO: 1822/167A

GENERAL

LEADING ACADEMICIANS DISCUSS SOVIET ENERGY DEVELOPMENTS, TRENDS

Moscow PRAVDA in Russian 24 Dec 85 p 2

[Article under the rubric "Horizons of Science": "On the Brink of the 21st Century"]

[Excerpts] The Presidium of the USSR Academy of Sciences held a meeting of leading scientists and specialists from the Academy and the State Committee for Science and Technology in the field of power engineering, for the benefit of the press, television, and radio people. The scientists told about progress on the USSR Energy Program and problems in accelerating scientific-technical progress in the energy field. We offer excerpts from the scientists' statements to the reader today.

Academician A. Aleksandrov

For us uninterrupted development of the energy system on the scale that will be needed by the country's economy in the future is entirely realistic. A reorientation is envisioned to use of those resources -- atomic energy, natural gas, and coal -- of which there are adequate long-run supplies.

The pre-Congress documents of the CPSU formulated the major tasks that must be accomplished before the year 2000. One of them is to follow an active energy-conservation policy based on accelerating scientific-technical progress in all elements of the national economy and to conserve fuel and energy by every means.

Academician L. Melentyev

Overall the basic strategy in the field of energy resources is, in the first stage, until the start of the 1990's, secure greatest growth in gas, and then later make broad use of nuclear fuel and inexpensive coal. This makes it possible to produce relatively inexpensive electricity and to convert to fuller electrification of the economy.

Production of electricity will increase much more rapidly than the extraction and production of primary energy resources. The share of electric energy in final energy use will roughly double over the current level.

Energy conservation is an important component of the program. Until recently we thought mainly about how to produce more energy. It is turning out to be more advantageous to conserve it. Calculations show that in any case at least 75-80 percent of the growth in demand for fuel is more advantageously covered by conservation.

Academician M. Styrikovich

The most rational path is to accelerate the extraction of our Siberian coals. In addition to Ekibastuz we have two more enormous basins which have only partially been brought into production. They are the Kuznets, which has first-class coal, mostly high-calorie and low-sulfur, and of course, the Kansk-Achinsk basin with its exceptionally cheap coal. It will serve first of all to supply all the swiftly growing energy needs of Siberia, to which energy-intensive production facilities are moving. Energy supply to Siberia cannot, as the experience of low-water years has demonstrated, rely entirely on hydroelectric plants. It is also significant that with nominal loading a thermal power plant using Kansk-Achinsk coal produces cheaper energy than a hydroelectric plant.

The challenge has now been posed of significantly reducing the use of mazut oil as a fuel, first of all at thermal plants. What will happen to all the existing power units that use mazut? Switch them to coal? This is, of course, technically feasible, but it is expensive and requires the units to be down for a long time. But we have natural gas, with significant reserves. We will not need to reduce the extraction of gas until at least the middle of the next century. Gas is the ecologically optimal organic fuel.

But gas is a precious fuel, and we must take a proprietary attitude toward gas consumption. On the long gas pipelines (up to 6,000 kilometers) today we are already using 10-15 percent of the gas for the gas turbines of the compressor plants. Incidentally, this figure can be reduced one-third using secondary energy resources from the gas turbines, and by half where there is heat consumption in the local area. This is an enormously important challenge; after all, already today we are using up to 40 billion cubic meters of gas a year for the internal needs of the gas pipelines, and this figure will more than double by the year 2000 if the drive system is not changed. But if we switch to electrical drive, no gas will be consumed at all; this, however, requires incorporation of large (25 and more megawatts) motors with control of the number of revolutions and building the needed number of atomic power plants to supply them with inexpensive electricity.

Doctor of Technical Sciences V. Dobrokhotoy

In the future 60-80 percent of all growth in electricity production at thermal power plants will come from using low-grade solid Siberian fuels. Our country is one of the leaders in the use of low-grade fuel in the power system. Nowhere else in the world are there such power plants as Ekibastuz, with its capacity of 4 million kilowatts. It uses coals with ash content of 52-55 percent. They had to search for new technical concepts there. But even more complex problems

must be solved in incorporating the coals of the Kansk-Achinsk basin, where the first of a series of 6.4 million kilowatt power plants using high-moisture coals is being built. Unique Soviet experience with the use of shales in the energy industry also attracts the attention of foreign specialists.

Academician A. Sheyndlin

Evaluations show that if contemporary technologies are used, synthetic liquid fuels from Kansk-Achinsk coals would already be competitive with petroleum fuels today. We are somewhat slow in development and incorporation of domestic technologies.

We have proposed a promising technology for direct hydrogenation of coal, but it appears that we will need 3-5 more years before it can be recommended to industry. Another method of producing synthetic fuel, involving gasification of solid fuels and subsequent synthesis of motor fuel from the resulting gas is, unfortunately, being developed more slowly than we need.

A promising way to increase the efficiency of the power sector is broad use of combined energy units with MHD (magnetohydrodynamic) generators. We already have more than 20 years of experience with the world's first composite MHD unit. Now the large Ryazan MHD-block with a capacity of 582 megawatts is under construction. This is a major advance by domestic science and engineering. In this we are ahead of other countries, the United States in particular, by 5-7 years.

Academician I. Glebov

Under current conditions the questions of raising the reliability and efficiency of power equipment and reducing its materials-intensiveness are crucial. And reliability is given priority. A great deal of work is being done in our country to raise the reliability of equipment for all types of power plants, transmission lines, and equipment in the energy consumption system. The question of increasing the unit capacity of units is not being taken off the agenda because large machines have the best efficiency and materials-intensiveness indicators.

We are operating the world's largest single-shaft energy block (1,200 megawatts at 3,000 rpm). For atomic power plants we have incorporated turbines and generators with capacities of 1 million kilowatts at 1,500 rpm. A block of the same capacity, but operating at 3,000 rpm, has recently been built. The construction of a faster block makes it possible to reduce materials expenditure by 15-20 percent. The rotor of such a turbogenerator weighs 91, not 150 tons.

The conversion to standardized energy equipment will have a large impact. Production of a unified series of turbogenerators with capacities up to 800 megawatts is now beginning. The decision has been made that standardized generators will be used in all the CEMA countries.

A promising new line of development in turbogenerator building is the new water cooling system for the rotors. These machines have been named "turbogenerators with triple water." The Ryazan GRES is successfully operating two

machines with capacities of 800,000 kilowatts each. Conversion to the new machine series with complete water cooling is planned.

The use of superconductivity in generators promises a great materials savings and a reduction of losses. We have built the world's first machine with 20,000 kilowatts capacity in our country. Work is now underway to build a superconducting turbogenerator with a capacity of 300,000 kilowatts.

Work on building AC machines with regulated speed is developing intensively. The significance of this work is illustrated by the fact that electric drives now consume roughly 60 percent of all electricity. The new machines will be more reliable and economical.

Academician V. Legasov

Nuclear sources of energy appear to be the most promising today, despite the markedly reduced rate of their construction in certain countries. These sources are most universal; they can generate hot water, steam, electricity, and synthetic fuel and it is easy to vary their locations. But the main thing is that they hardly contaminate the environment at all.

Academician V. Kirillin

We should not forget the other sources of energy either. Among others, there is the use of solar energy on a large scale. This is not for today, but rather tomorrow, possibly even the day after tomorrow; but like geothermal energy, solar energy must be used more extensively to produce heat or hot water.

Foremost among the other types of self-regenerating energy sources we should mention biogas. It can be obtained from the waste products of animal husbandry, food, microbiological, forest, and some other sectors of industry, and also, finally, from city waste. Biogas cannot be produced on a large scale, but it is an extremely valuable energy raw material. Biogas units in agriculture are simple and pay for themselves in one year.

11176
CSO: 1822/137

GENERAL

BRIEFS

RURAL POWER ORGANIZATION--It has to be admitted that the light situation in the countryside was much better when they had their own power service. Glavsel-elektro [possibly Main Administration for Rural Electrification and Power] was an organization fully interested in the development of agricultural production. Upon receiving this system in 1963 the USSR Ministry of Power and Electrification eliminated its autonomously financed oblast operations administrations and rayon divisions and limited its own activities to construction and operation of power transmission lines and transformer substations. There was no way this could suit rural workers. And before long, on the initiative of the farms and local party and Soviet bodies, interfarm enterprises for power and electrification of agriculture under the name "Selkhozenergo" began to appear. This cooperative now covers more than two-thirds of the country's kolkhozes and sovkhozes. During its period of existence Selkhozenergo has proven its vitality. It appears that it is now time to give Selkhozenergo associations full authority and full responsibility for the operation of rural power equipment. The formation of an All-Union Production Economic Accountability Association for Power and Electrification of Agriculture within the country's agro-industrial system (the ministries of agriculture and power and electrification as well as Goskomselkhoztekhnika are in agreement with this) would allow a fundamental improvement in the situation and elimination of parallelism and duplication in the work of the power services of the ministries and departments of the country's agroindustrial complex. [by N. Nikulina] [Excerpt]]Moscow SELSKAYA ZHIZN in Russian 16 Nov 85 p 2] 11176

ESTONIAN POWER SYSTEM--Estonian power workers are finishing the 11th Five-Year Plan with good results. Since the beginning of 1985 they have produced 13,024 billion kilowatt-hours of electricity, sold output worth 225 million rubles, conserved 29,500 tons of standard fuel, shipped 2.8 million tons of shale ash to agriculture, saving 464,000 rubles compared to the plan by reducing prime cost. [by V. Kheynshteyn] [Excerpt]]Tallinn SOVETSKAYA ESTONIYA in Russian 22 Nov 85 p 3] 11176

AZERBAIJAN POWER SYSTEM--Supplying the consumers of electricity and heat, enterprises of Azglavenergo are striving to fulfill plan assignments for technical-economic indicators. According to the results for the first 11 months republic power workers are even with the plan for electricity production: production has been 18.6 billion kilowatt-hours since the start of the year. The plan for distribution of heat was overfulfilled by 224,000 gigacalories, and the assignment for commodity output was also surpassed. The collective of

Azglavenergo also faces important challenges. In the coming year plans call for producing 22.6 billion kilowatt-hours of electricity and 15.6 million gigacalories of heat. In the more distant future are launching of the first power unit at the Azerbaijan AES, the Novo-Bakinskaya TETs, and the Yenikenskaya, Kirzanskaya, Alazanskaya, Ismaillinskaya, Khudaferinskaya, and Gyz-Galasinskaya hydroelectric plants plus reconstruction and re-equipping of various existing capacities. [Excerpts] [Baku VYSHKA in Russian 21 Dec 85 p 2] 11176

END