



NAVAL FACILITIES ENGINEERING SERVICE CENTER
Port Hueneme, California 93043-4370

Technical Report

TR-6005-OCN

**'EMOOR' - A PLANNING/PRELIMINARY DESIGN TOOL
FOR EVALUATING SHIP MOORINGS
AT PIERS AND WHARVES**

by

William N. Seelig, P.E.

May 1998
Rev B

Prepared for:

Commander, Naval Facilities Engineering Command
Criteria Office (15C)

19990429 078

Approved for public release; distribution is unlimited.

REPORT DOCUMENTATION PAGE

Form Approved
OMB No. 0704-0188

Public reporting burden for this collection of information is estimated to average 1 hour per response, including the time for reviewing instructions, searching existing data sources, gathering and maintaining the data needed, and completing and reviewing the collection of information. Send comments regarding this burden estimate or any other aspect of this collection of information, including suggestions for reducing this burden to: Washington Headquarters Services, Directorate for Information Operations and Reports, 1215 Jefferson Davis Highway, Suite 1204, Arlington, VA 22202-4302, and to the Office of Management and Budget, Paperwork Reduction Project (0704-0188), Washington, DC 20503.

1. AGENCY USE ONLY (Leave blank)	2. REPORT DATE <p style="text-align: center;">May 1998</p>	3. REPORT TYPE AND DATES COVERED <p style="text-align: center;">Final</p>	
4. TITLE AND SUBTITLE 'EMOOR' A PLANNING/PRELIMINARY DESIGN TOOL FOR EVALUATING SHIP MOORINGS AT PIERS AND WHARVES		5. FUNDING NUMBERS	
6. AUTHOR(S) Seelig, W.N..			
7. PERFORMING ORGANIZATION NAME(S) AND ADDRESS(ES) Naval Facilities Engineering Service Center 1100 23rd Ave Port Hueneme CA 93043-4370		8. PERFORMING ORGANIZATION REPORT NUMBER TR-6005-OCN	
9. SPONSORING/MONITORING AGENCY NAME(S) AND ADDRESS(ES) Naval Facilities Engineering Service Center 1100 23rd Ave Port Hueneme CA 93043-4370		10. SPONSORING/MONITORING AGENCY	
11. SUPPLEMENTARY NOTES			
12a. DISTRIBUTION/AVAILABILITY STATEMENT Approved for public release; distribution is unlimited.			12b. DISTRIBUTION CODE
13. ABSTRACT (Maximum 200 words) A spread sheet program is presented for estimating safe mooring limits for ships at piers and wharves. This spreadsheet uses moorings of U.S. Navy surface ships to calibrate an optimum ideal mooring and determine mooring efficiency.			
14. SUBJECT TERMS Ship Mooring			15. NUMBER OF PAGES 60
			16. PRICE CODE
17. SECURITY CLASSIFICATION OF REPORT <p style="text-align: center;">U</p>	18. SECURITY CLASSIFICATION OF THIS PAGE <p style="text-align: center;">U</p>	19. SECURITY CLASSIFICATION OF ABSTRACT <p style="text-align: center;">U</p>	20. LIMITATION OF ABSTRACT <p style="text-align: center;">U</p>

EXECUTIVE SUMMARY

Commander, Naval Facilities Engineering Command 15C tasked Naval Facilities Engineering Service Center (NFESC) to develop a tool to assist in ship mooring planning and preliminary design. Analyses of a wide variety of actual DoD ship moorings showed that 'mooring efficiency' is a parameter that can be used to:

- Quickly
- Reliably
- Inexpensively

assess mooring requirements.

A number of moorings designed by NFESC at a number of different facilities for a variety of ships were analyzed for mooring efficiency. For all of these cases mooring efficiency was found to be a simple function. Efficiency can then be used as a means to an end; to develop a simple planning/preliminary design tool.

'EMOOR' is a program that uses mooring efficiency to determine:

- Required overall pier/wharf capacity
- Required number of pier/wharf fittings
- Required pier/wharf fitting capacity
- Number of spring lines required, and
- Number of breasting lines required

for a given ship under a specified set of environmental conditions.

A preliminary test version, 'EMOOR98' (in spread sheet form) is provided with this report.

The user inputs ship class and draft, water depth, wind speed, current speed and mean vertical angle of the breasting lines. At the present time (March 1998) 26 ship classes are loaded into EMOOR98.

NOTICE

The information, including technical and engineering data, figures, tables, designs, drawings, details, procedures and specifications, presented in this report are for general information only. While every effort has been made to insure it's accuracy, this information should not be used or relied upon for any specific application without independent competent professional examination and verification of it accuracy, suitability and applicability, by a licensed professional.

This report is provided without warranty of any kind. Anyone making use of this material does so at his own risk and assumes any and all liability resulting from such use. The entire risk as to quality or usability of the material contained within is with the reader. In no event will the author or U.S. Navy be held liable for any damages including lost profits, lost savings or other incidental or consequential damages arising from the use of or inability to use the information contained within.

The reader is especially cautioned to use care when using the draft spreadsheet program EMOOR98.XLS that is included with this manual. This spread sheet is not write-protected. Any accidental or other change to any of the ship's parameters, in Columns E and higher, or any of the spread sheet equations or computations could result in erroneous results.

CONTENTS

<u>Section</u>	<u>Title</u>	<u>Page</u>
	EXECUTIVE SUMMARY	1
	CONTENTS	2
1.0	BACKGROUND	3
2.0	PURPOSE	3
<u>METHOD DEVELOPMENT</u>		
3.0	EVALUATION OF PIER/WHARF MOORING	4
3.1	DEFINITIONS	4
3.2	IDEALIZED MOORINGS	6
3.3	MOORING EFFICIENCY, e	15
3.4	EFFICIENCY OF A SIMPLE MOORING	19
4.0	EXAMPLE OF MOORING AN LHA-1 AT A PIER	21
5.0	OTHER EXAMPLES OF MOORING EFFICIENCY	26
5.1	SHIPS MOORED WITH SYNTHETIC LINES	26
5.2	SHIPS MOORED WITH CONSTANT TENSION WINCHES	30
5.3	MOORING FACTOR, r	32
<u>METHOD APPLICATION</u>		
6.0	PLANNING/PRELIMINARY DESIGN	35
6.1	NEED	35
6.2	APPROACH	36
7.0	EMOOR98	38
8.0	EXAMPLES	42
9.0	SUMMARY AND CONCLUSIONS	42
	REFERENCES	44
	NOTATION	45
APPENDIX A	SAMPLE MOORINGS	

'EMOOR' - A PLANNING/PRELIMINARY DESIGN TOOL FOR EVALUATING SHIP MOORINGS AT PIERS AND WHARVES

by

William N. Seelig, P.E.

1.0 BACKGROUND

In order to keep U.S. Navy ships safely moored it is often necessary to quickly determine the approximate number of mooring lines required and the necessary capacity of the pier/wharf. Of special concern is heavy weather mooring of ships under repair that are unable to get underway. Therefore, Commander, Naval Facilities Engineering Command (NAVFACENGCOM 15C) tasked the Naval Facilities Engineering Service Center (NFESC) to develop a quick and easy, yet reliable, mooring evaluation tool to be used for planning and preliminary design.

2.0 PURPOSE

This report provides a program EMOOR, which is a quick and easy method of assessing ship moorings at piers and wharves. This tool is meant to be a preliminary design and planning tool. EMOOR98, a test version of this program in spread sheet form, is provided with this report.

The approach taken in this study was to: (a) develop an optimum ideal mooring, (b) quasi-statically analyze a free body diagram of the optimum ideal mooring for wind and current forces/moments, (c) define mooring efficiency in terms of the optimum ideal mooring, (d) evaluate the efficiency for a wide variety of actual moorings, and (e) combine all of these elements into an easy to use spread sheet that evaluates ship moorings at piers and wharves.

This report contains two types of information. Method development is presented in Sections 3.0, 4.0 and 5.0. Method application, which is intended as a stand-alone portion of the report, is given in Sections 6.0, 7.0 and 8.0.

METHOD DEVELOPMENT

Sections 3.0, 4.0 and 5.0 of this report give method development. These sections are intended for those interested in detailed information.

3.0 EVALUATION OF PIER/SHIP MOORINGS

The purpose of a pier or wharf mooring is to safely hold a ship in place. Several steps are taken in this section in order to better understand and evaluate given ship mooring designs:

1. Definitions are made
2. A simple mooring system is set up
3. Mooring efficiency is defined
4. Efficiency of a simple mooring is evaluated.

3.1 DEFINITIONS

In this report "x" is taken as the coordinate parallel with the ship longitudinal axis, "y" is the direction perpendicular to the ship (positive in the port direction) and "z" is the direction perpendicular to the water surface (positive upward). Figure 3.1 defines some terms and shows the coordinate system that is used throughout.

Angles in the horizontal plane (i.e. parallel with the water surface) and vertical plane (i.e. perpendicular to the water surface) are defined as shown in Figure 3.1.

In this report we define two categories of mooring line:

1. A "spring line" is defined as a line who's angle in the horizontal plane (θ_H) has an absolute value of less than 45 degrees, as shown in Figure 3.1. A key purpose of spring lines is to restrain a ship in the longitudinal direction at a pier or wharf.

2. A "breasting line" is defined as a line who's angle in the horizontal plane (θ_H) has an absolute value of greater than or equal to 45 degrees, as shown in Figure 3.1. A key purpose of breasting lines is to restrain a ship against a pier or wharf.

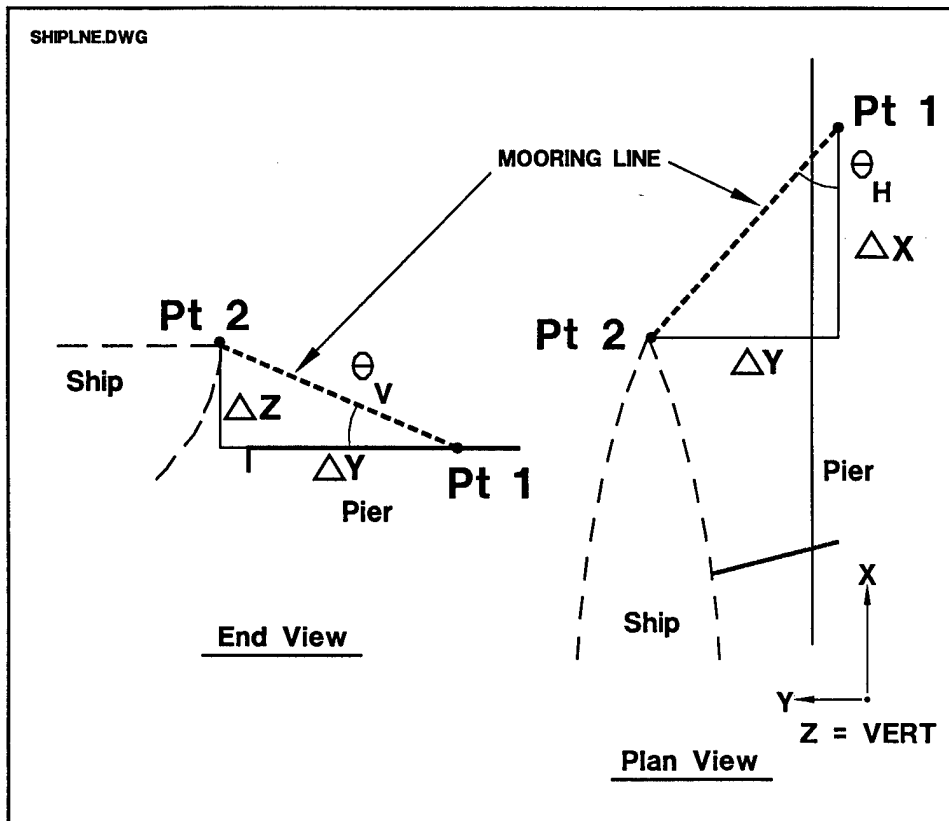

DEFINITIONS:

$$\theta_H = \tan^{-1} \left(\frac{\Delta Y}{\Delta X} \right)$$

$$\theta_V = \tan^{-1} \left(\frac{\Delta Z}{\Delta Y} \right)$$

IF $|\theta_H| < 45 \text{ deg} \rightarrow$ **SPRING LINE**

IF $|\theta_H| \geq 45 \text{ deg} \rightarrow$ **BREASTING LINE**

Figure 3.1 Definition of Some Terms

3.2 IDEALIZED MOORINGS

Simple ship/mooring systems, such as the one shown in Figure 3.2, are used to illustrate mooring principles. The idealized mooring shown in Figure 3.2 has four mooring lines, numbered 1 through 4. There are two spring lines, Lines 1 and 4, which hold the ship in the longitudinal direction. In addition, there are two breasting lines, Lines 2 and 3, which hold the ship against the pier or wharf. In this idealized example the line attachment points on shore are at the same elevation as the attachment points on the ship, so the vertical line angles, θ_v , are zero and the lines are parallel to the surface of the water. In this example the two breasting lines are perpendicular to the ship centerline, so the horizontal line angles, θ_H , are 90 degrees.

For simplification the current speed is first taken as zero and the wind is taken as blowing from shore with angles, θ_w , from 0 to 180 degrees. In this example: (a) the pier and fenders are not considered, (b) the line pretension is taken as zero and (c) the ship motion is assumed to be negligible.

An advantage of considering this simple example is that the quasi static mooring line tensions can be calculated using a free body diagram. In this example we define the line tensions as:

$$\text{EQUATION:} \quad T_1 \text{ and } T_4 = F_x \quad (3-1)$$

$$T_2 \text{ and } T_3 = (F_y/2) \pm (M/2X) \quad (3-2)$$

WHERE:

- T_i = tension in Line i
- F_x = force on the ship in the x-direction
- F_y = force on the ship in the y-direction
- M = moment on the ship due to the
wind and/or current
- X = x-distance from midships to breasting
line attachment point

To illustrate mooring computations, a loaded USS TARAWA (LHA-1) with draft of 26 feet subjected to 60 mph winds is placed in a simple mooring. In this example, the breasting lines are placed at half a ship length from midships (i.e. $X = 0.5 * L$, where $L =$ ship length). This case is shown in Figure 3.2.

In this example the wind force is $F_{xw} = 39.4$ kips (from methods in Seelig, 1997) for the wind parallel to the ship and $F_{yw} = 588.9$ kips for a broadside wind, where a kip is 1000 pounds of force.

For the cases of the wind parallel to the ship, the working capacity of Lines 1 and 4 must be able to resist the longitudinal forces. Therefore, $Fw1 = Fw4 = F_{xw} = 39.4$ kips for this case, where Fw is the working line tension capacity required. If a factor of safety of 3 is used, then the line break strength required for Lines 1 and 4 would be $Fb1 = Fb4 = 3 * Fw1 = 3 * 39.4 = 118.2$ kips.

Tensions in the breasting lines, Lines 2 and 3, are determined using equation (3-2). In design it is common practice to assume that the design wind can blow from any direction. Therefore, the working line tension capacity required for Line 2 is determined by finding which wind direction produces the highest tension in Line 2. The working line tension capacity required for Line 3 is also determined by finding which wind direction produces the highest tension in Line 3. Figure 3.3 shows the computed tensions in Lines 2 and 3 as a function of wind direction for this example. Therefore, the maximum required working tension capacities for Lines 2 and 3 are $Fw2 = 320.3$ kips and $Fw3 = 322.6$ kips, as shown in Figure 3.3.

For this example the combined working tension capacities of the spring lines, $Fw1 + Fw4 = 2 * 39.4 = 78.8$ kips, is twice the longitudinal force, as shown in Figure 3.4. The combined working capacities of the breasting lines, $Fw2 + Fw3 = 320.3 + 322.6 = 642.9$ kips, is approximately 9% higher than the broadside environmental force at an angle of 90 degrees (i.e. $((642.9/588.9)-1)*100\% = 9\%$). The 9% extra line tension working capacity in the breasting lines for an LHA is required to resist the environmental moments on the ship. Note that no mooring component is required in the Z direction, because buoyancy supports the ship in the z -direction.

Figure 3.4 shows that broadside quasi-static forces dominate in this case. The longitudinal wind force is only 7% of the broadside wind force (i.e. $(39.4/588.9)*100\% = 6.69\%$), because the ship is relatively streamlined.

The sum of the mooring line working tension capacities for the optimum ideal moorings is a baseline parameter useful for quantifying mooring capacity. For this example the sum of the line working tension capacities is $Fw1 + Fw2 + Fw3 + Fw4 = 39.4 + 320.3 + 322.6 + 39.4 = 721.7$ kips for the case shown in Figure 3.2 with 60 mph winds.

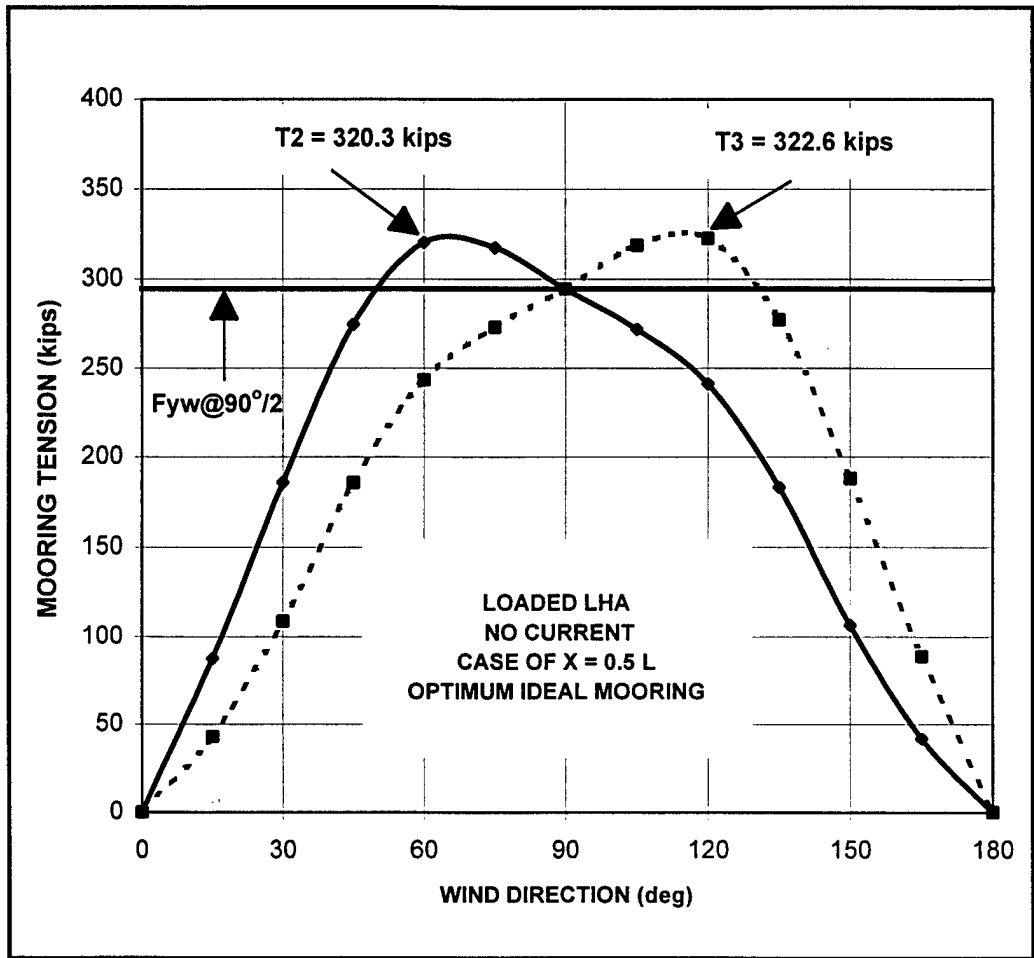
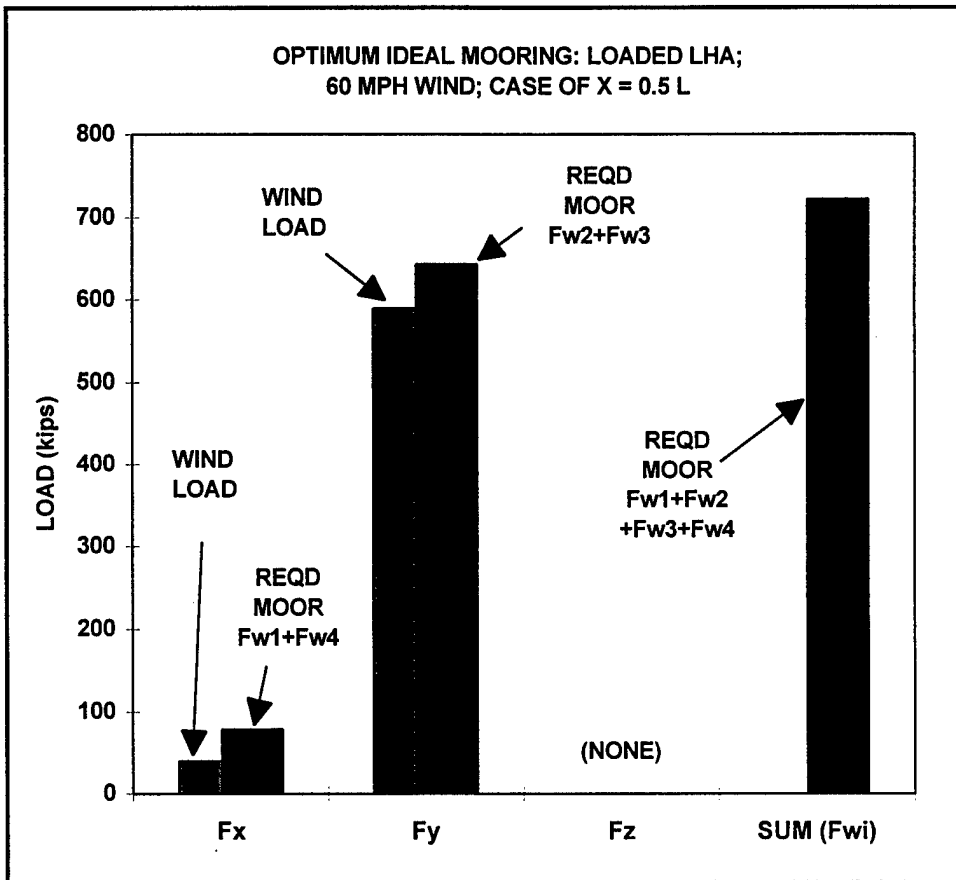

Figure 3.3 Example of Breasting Line Tensions for a Wind Speed of 60 mph (28.2 m/s)



	<i>End-On</i>	<i>Broadside</i>
WIND FORCE (kips)	39.4	588.9

	<i>Stern</i>	<i>Bow</i>	<i>Sum</i>
LINE WORKING TENSIONS (kips)	<i>Fw1</i> = 39.4	<i>Fw4</i> = 39.4	78.8
LINE WORKING TENSIONS (kips)	<i>Fw2</i> = 320.3	<i>Fw3</i> = 322.6	642.6
<i>Fw1 + Fw2 + Fw3 + Fw4</i> (kips)			721.7

Figure 3.4 Sample Results for an LHA Optimum Ideal Mooring

As shown in the above example, the sum of required mooring line working tensions, defined as Fw^* , is a parameter that can be used to characterize mooring requirements for a given ship in a given set of environmental parameters.

Figure 3.5 shows the sum of required mooring line working tensions as a function of the distance, X , from midships to the breasting line attachment points. The closer the breasting lines are placed to midships, the less efficient these lines are at resisting moments. Consequently, the higher the sum of required mooring line working tensions, Fw^* , increases as X/L decreases, as shown in Figure 3.5.

Horizontal and vertical angles of the mooring lines, as defined in Figure 3.1, have an effect on the sum of required mooring line working tensions. Figure 3.6 shows Fw^* as a function of the horizontal breasting line angle, θ_H , and the vertical breasting line angle, θ_V , * for the LHA example with 60 mph winds. The vertical angle, which is a function of the vertical and horizontal distances from pier fitting to vessel chock, as shown in Figure 3.1, can be especially important. If the ship fittings are much higher than the pier and the ship is close to the pier, then the resulting sum of required mooring line working tensions, Fw^* , may be high, as shown in Figure 3.6.

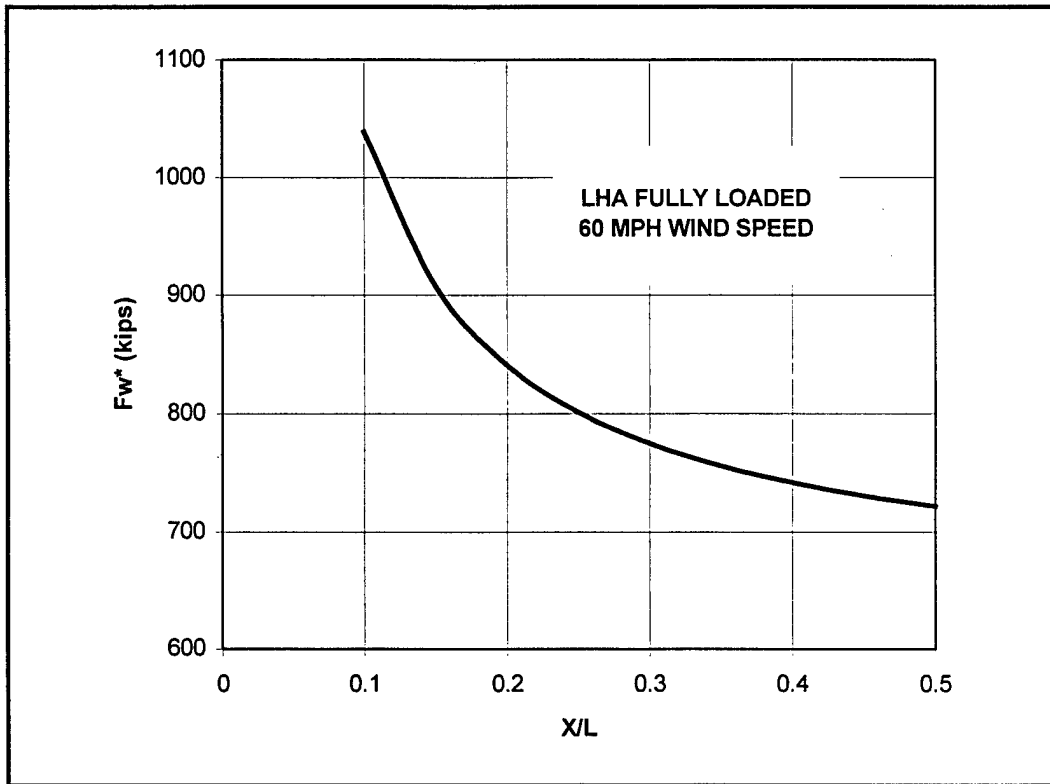
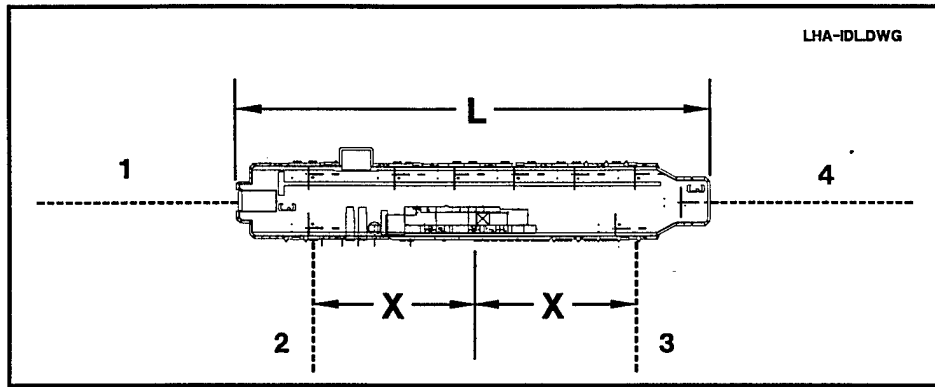

Figure 3.5 Total Mooring Capacity Required as a Function of X/L

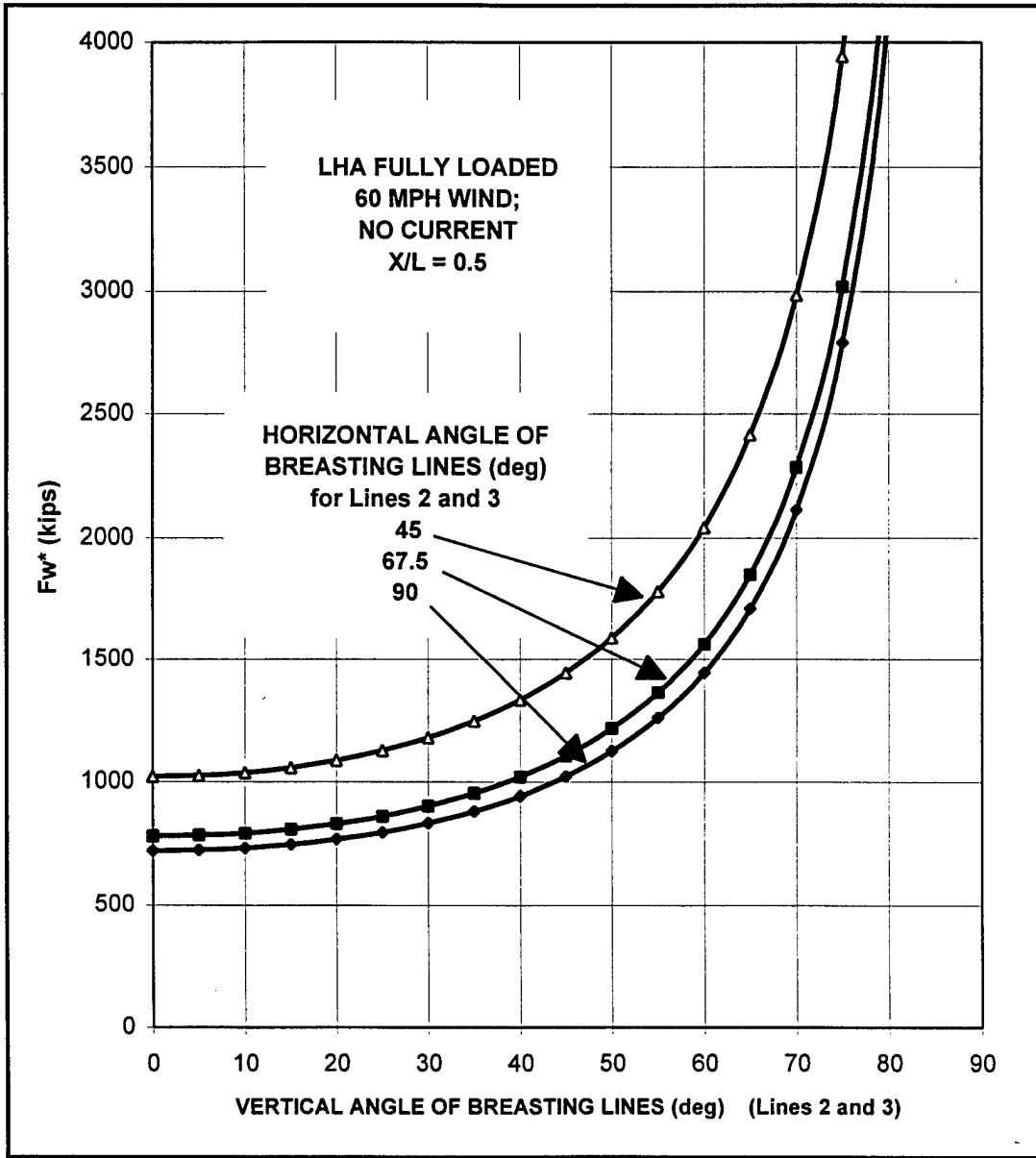
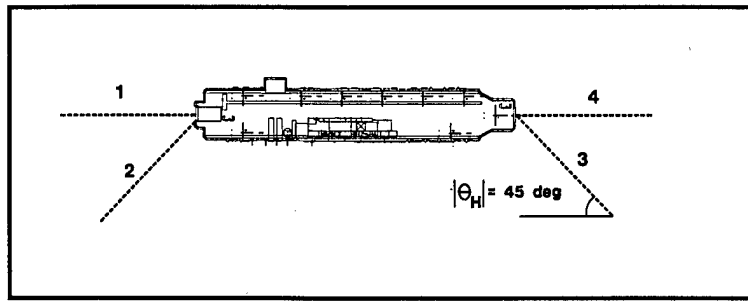

Figure 3.6 Effect of Horizontal and Vertical Breasting Line Angles, θ_H and θ_V on F_w^*

3.3 MOORING EFFICIENCY, e

The examples illustrated in Section 3.2 show that sum of required mooring line tension capacities is a parameter that can be used as a baseline parameter to quantify mooring capacity for a given ship at a given pier with a specified environment. In this section, the sum of mooring line working tension capacities is used to define mooring efficiency for ships at wharves and piers.

3.3.1 EFFICIENCY DEFINITION

'Efficiency' is a concept used to characterize systems. It is most commonly a dimensionless number that ranges from 0.0 to 1.0 (i.e. 0 to 100%). In this section we define mooring efficiency, e , for ships at piers and wharves as:

EQUATION:
$$e = F^* / Fw^* \quad (3-3)$$

WHERE:

Fw^* = the denominator; sum of mooring line working capacities for an actual mooring (Section 3.3.2)

F^* = the numerator; sum of required mooring line working capacities for the optimum ideal mooring (Section 3.3.3)

Predictions of required mooring capacity can be made by using equation (3-3) rearranged by placing the required mooring line capacity on the left side:

EQUATION:
$$Fw^* = F^* / e \quad (3-3a)$$

The numerator of the left side of equation (3-3a) is the sum of working line capacity from the optimum ideal mooring. If the mooring efficiency, e , is known, then equation (3-3a) can be used to estimate required mooring capacity.

Mooring efficiency, as defined in equation (3-3), is the ratio of the sum of mooring line working capacities for the optimum ideal mooring to the sum of mooring line working capacities for an actual mooring, based on the same applied environmental conditions.

The primary reason for defining efficiency is to develop a single dimensionless number that describes the effectiveness of a given mooring in

safely securing a ship under given design conditions. Values of efficiency are used to understand what parameters are important and as an aid to evaluating or improving ship moorings.

High values of mooring efficiency indicate that a given number and strength of mooring lines are being used effectively to hold a ship in a given set of environmental parameters. A low value of mooring efficiency suggests that mooring lines are not being used very effectively.

3.3.2 EFFICIENCY DENOMINATOR (F_w^*)

The denominator of equation (3-3) is the sum of mooring line working capacities for an actual mooring. The mooring system can be simple, such as the system shown in Figure 3.7, or a more complex and realistic mooring system.

The denominator is found by first defining a mooring of a given ship with a given set of lines. The design current speed and direction are applied to the ship/mooring system. A wind of low speed is applied to the ship/mooring system. A sweep of the wind is made for various directions to the ship and the factor of safety of each mooring line is determined. If all lines have a factor of safety greater than the specified factor of safety, FS , then the wind speed is increased. This process is repeated until the maximum safe wind speed, V_w , where one of the lines just reaches the specified factor of safety, is determined.

The denominator is defined as the sum of mooring line working tension capacities, equation (3-4).

EQUATION:
$$F_w^* = \sum_{i=1}^N F_{w_i} \quad (3-4)$$

WHERE:

- F_w^* = sum of mooring line working capacities
for all mooring lines for an actual mooring
- F_{w_i} = working capacity of Line i
- F_b = line breaking strength
- FS = specified factor of safety
- N = number of mooring lines

3.3.3 EFFICIENCY NUMERATOR (F^*)

The mooring arrangement shown in Figure 3.8 is defined as the 'optimum ideal' mooring with four mooring lines. For this case the lines are parallel to the water surface and breasting lines are placed at $X=0.5*L$, where L = ship length.

The numerator is determined by applying the same design current at the design direction, as was used in Section 3.3.2. The maximum safe wind speed, V_w , from Section 3.3.2 is also applied to the optimum ideal mooring shown in Figure 3.8. The numerator, F^* , is defined as the sum of required mooring line working tension capacities for the optimum ideal mooring or:

EQUATION:
$$F^* = \sum_{i=1}^N Fw_i \quad (3-5)$$

WHERE:

- F^* = sum of mooring line working capacities
for all mooring lines for the optimum ideal
mooring shown in Figure 3.8
- Fw_i = working capacity of Line i
- F_b = line breaking strength
- FS = specified factor of safety
- N = number of mooring lines = 4

Sample optimum ideal mooring calculations are given in Section 3.2.

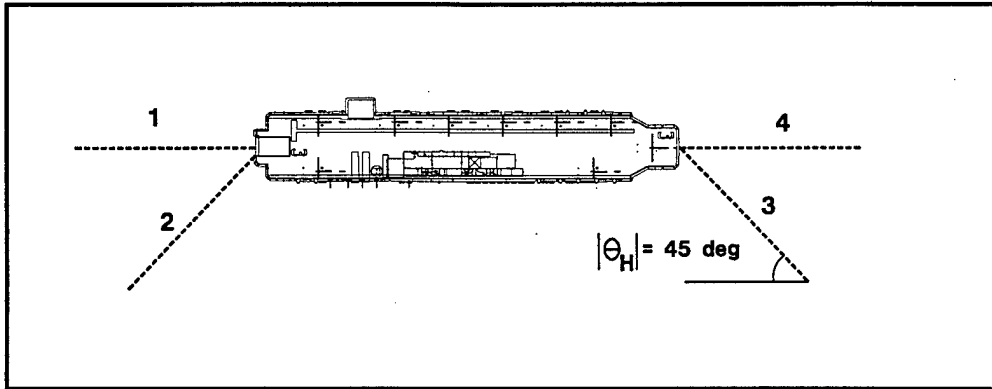

Figure 3.7 A Actual Ship Mooring System

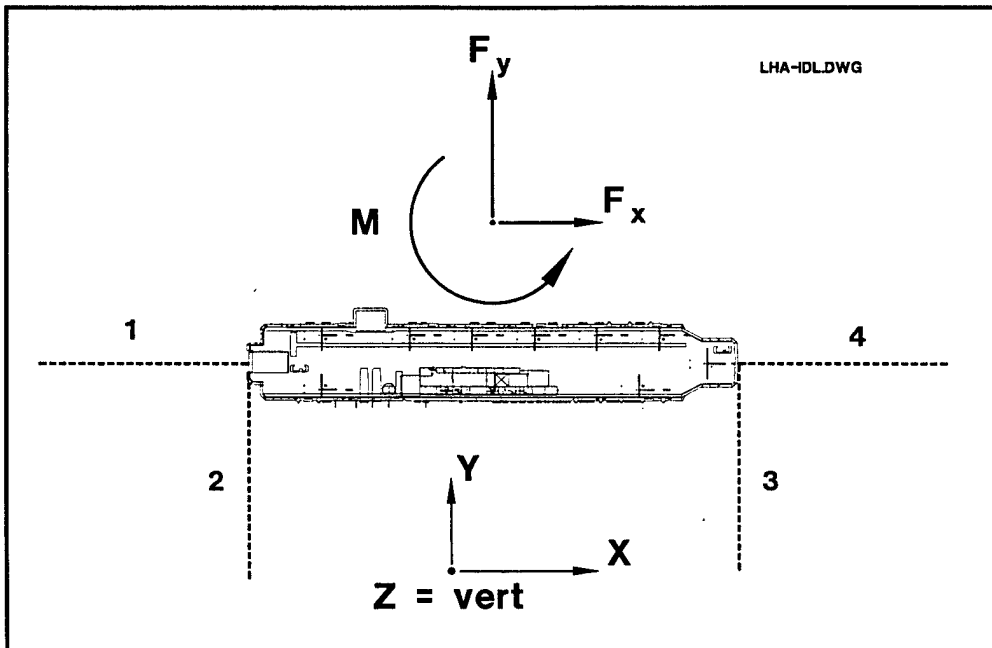

Figure 3.8 The Optimum Ideal Mooring
(Lines Parallel to the Water Surface and
Breasting Lines Spaced at $X=0.5 * L$ from Midships)

3.4 EFFICIENCY OF A SIMPLE LHA MOORING

In this section a simple mooring of four lines used to secure an LHA-1, shown in Figure 3.7, is evaluated for mooring efficiency. In this example the spring lines, Lines 1 and 4, are parallel to the ships longitudinal axis and to the water surface. The horizontal and vertical angles of the breasting lines, Lines 2 and 3, are varied. Figure 3.9 shows mooring efficiency as a function of the vertical angle, θ_v , of the breasting lines. The abscissa of Figure 3.9 is the vertical angle of the breasting lines, θ_v , and ordinate of the figure is the mooring efficiency, e . Curves are shown for horizontal breasting line angles, θ_h , of 45, 67.5 and 90 degrees.

Figure 3.9 shows that for this example, all of the mooring arrangements have rather high efficiencies as long as the vertical angle of the breasting lines is 20 degrees or less. Cases with the horizontal breasting line angles of 67.5 to 90 degrees have similar mooring efficiencies. However, breasting lines with horizontal angles of 45 degrees have significantly less efficiency.

Figure 3.9 shows in this simple example that vertical breasting line angle, θ_v , is very important. Moorings with a high vertical breasting line angle are inefficient at safely mooring ships.

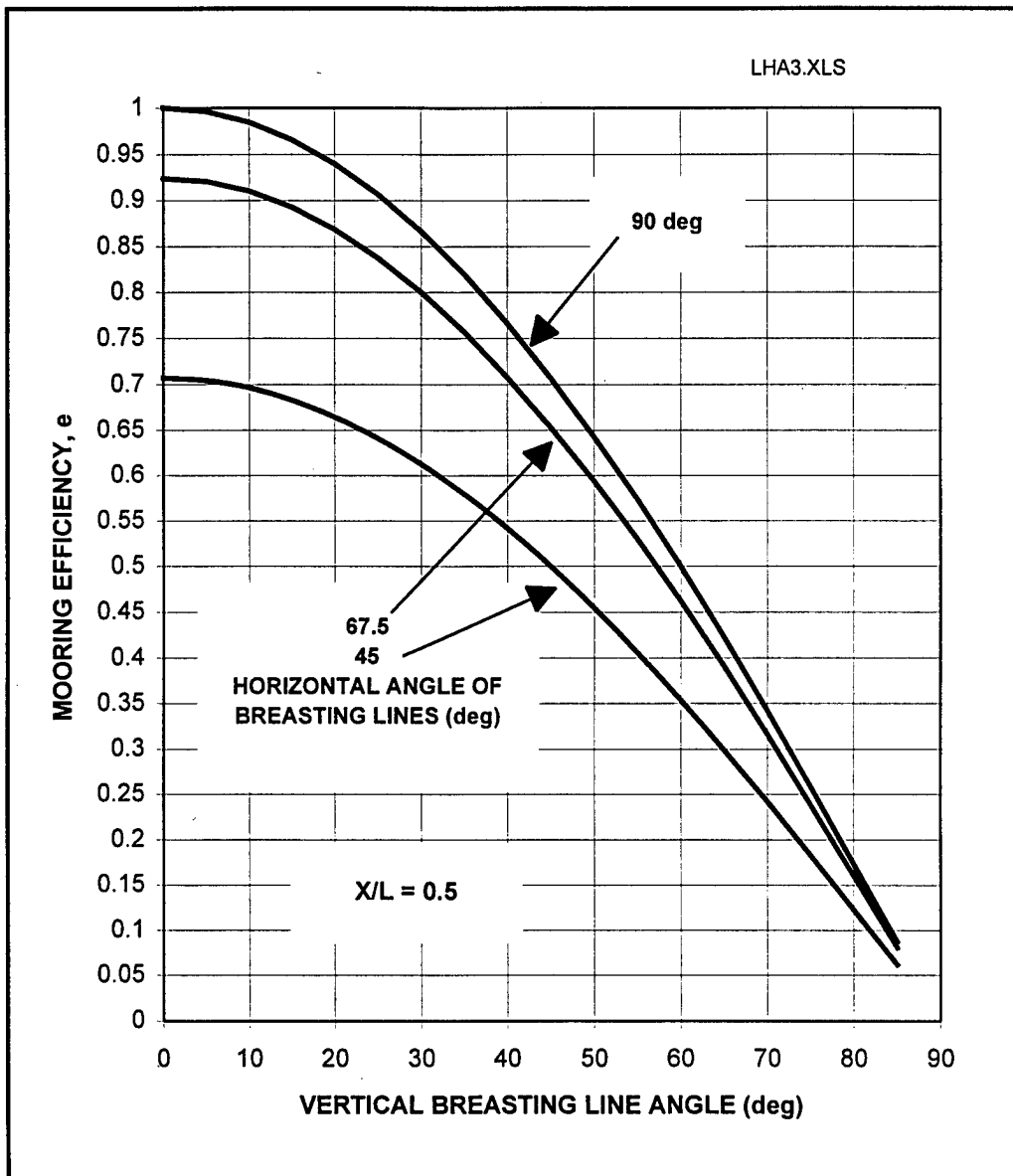

Figure 3.9 Mooring Efficiency for an LHA Moored with Four Lines as a Function of Breasting Line Horizontal and Vertical Angle Variation

4.0 EXAMPLE OF MOORING AN LHA-1 AT A PIER

Take the case of an LHA-1 moored to a pier, as shown in Figure 4.1. The pier is taken as 100 feet (30.5 m) wide and rope attachment points on the bollards are taken as 1 foot (0.3 m) above the pier deck and 10 feet (3 m) back from the edge of the pier. Bollards with 100-tons (0.89 MN) working capacity are placed at 60-foot (18.3 m) intervals along the pier. Marine fenders with a diameter of 10 feet (3.3 m) are placed at 100-foot (30 m) spacing along the pier. The pier is taken as 10 feet (3.28 m) above low water datum. Analyses are performed for water levels at 3.3 feet (1 m) above low water datum. Three parts of line are used at each mooring point and a single part of line is taken as having a breaking strength of 180 kips (0.801 MN). A factor of safety of 3.0 is specified, so each three-part set of lines has a working capacity of $3 \cdot 180 / 3.0 = 180$ kips (0.801 MN).

In this example the ship is to be moored as safely as possible. Therefore, 14 sets of lines are used (number of parts of line = $14 \cdot 3 = 42$). The sum of the working tension capacity of the mooring lines is $F_w^* = 14 \cdot 180 = 2520$ kips.

CASE (A) - FENDERS SEPARATING THE SHIP FROM THE PIER

Analysis of the mooring arrangement in Figure 4.1 using methods in MIL-HDBK-1026/4 (draft of 24 Dec 1997), shows that the maximum safe wind speed with a factor of safety of 3.0 or higher on all mooring lines is $V_w = 60$ mph for the case of no current.

The optimum ideal mooring is analyzed for LHA-1 with 60 mph winds and the optimum ideal sum of mooring line working capacities was found to be $F^* = 721.8$ kips from Figure 3.4. Efficiency of the mooring shown in Figure 4.1 is determined using equation (3-3) as:

$$e = 721.8 / 2520.0 = 0.286$$

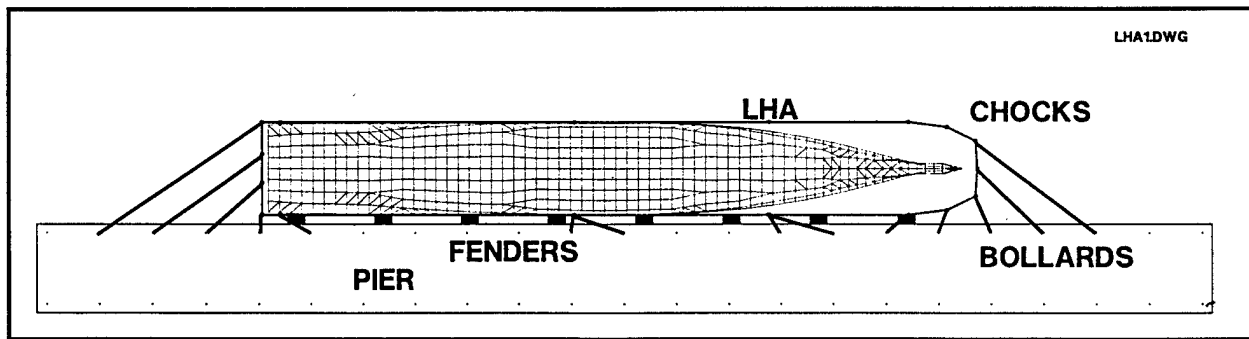
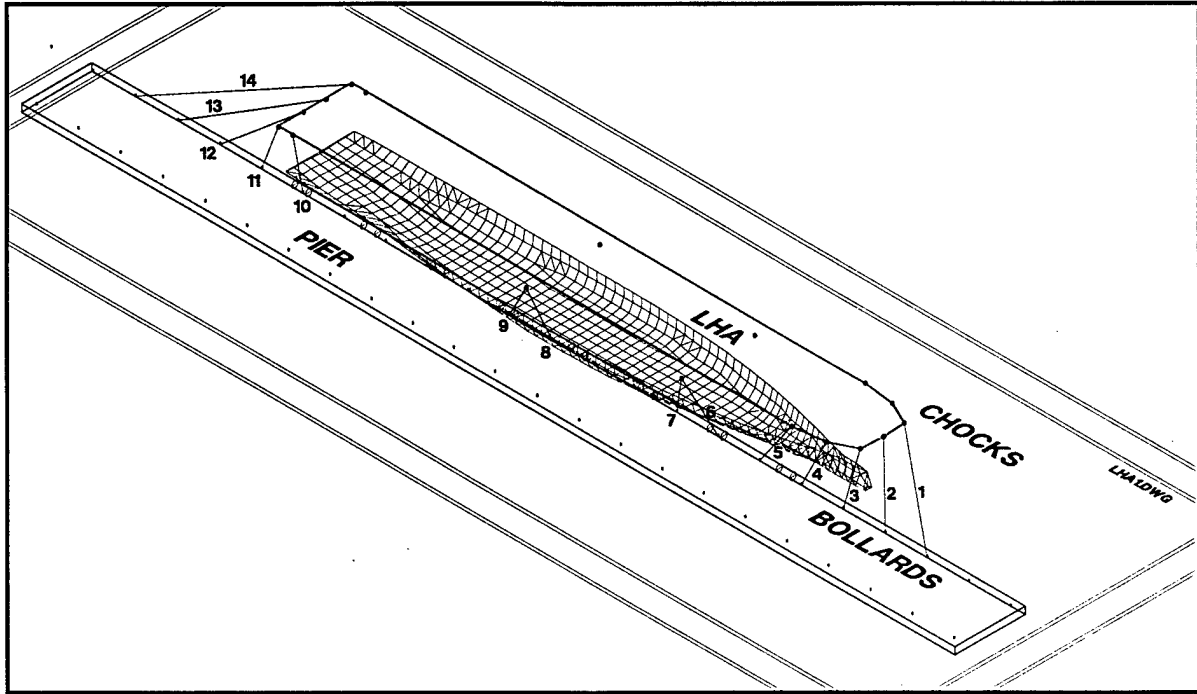

Figure 4.1 Case (A) - An LHA Mooring at a Pier
(Model 5B)

The mooring chocks and fittings on LHA-1 are high off the water. With only marine fenders as separators between the ship and pier (see Figure 4.2), the vertical line angles are high and the mooring efficiency is very low with $e = 0.286$. The average vertical angle of the breasting lines is 47.5 degrees. The horizontal angles of the breasting lines are less than the optimum value of 90 degrees due to the location of the pier fittings (see Figure 4.1). This combination of factors, together with imperfect load sharing between synthetic mooring lines, produces low mooring efficiency.

As shown in Figure 4.3 (A), the mooring efficiency of an LHA at a typical pier with marine fenders as separators is low with $e = 0.286$. This means that the required mooring line working tension capacity is $1/e = 1/0.286 = 3.5$ or 3.5 times that required of the optimum ideal mooring.

One way to increase mooring efficiency is to put additional horizontal separation between the ship and pier. This will improve the efficiency of the breasting lines by improving both the horizontal and vertical angles. Load sharing between the lines also improves as separation between the ship and pier increases, because the mooring lines are longer and have more stretch.

CASE (B) - CAMELS AND FENDERS

Figure 4.3 (B) shows an LHA moored with the same number and type of synthetic lines, but with 32-foot (9.75 m) wide camels and fenders separating the ship from the pier. In this case the average vertical angle of the breasting lines is 29.8 degrees. The addition of camels increases the mooring efficiency over 70%, (i.e. from $e = 0.286$ to $e = 0.494$), as shown in Figure 4.3. Adding the camels also increases the safe wind speed to 79 mph for the case of no current. This mooring has $F^* = 1247$ kips and $Fw^* = 2520$ kips.

CASE (C) - CAMELS, FENDERS, LINES TO OTHER SIDE OF THE PIER

In an emergency mooring lines could be run across the pier to fittings on the other side of the pier, which: (1) reduces the average vertical breasting line angle to 13.9 degrees, (2) increases the breasting line horizontal angles to approximately 90 degrees, and (3) lengthens the mooring lines for improved load sharing. This mooring (Figure 4.3 C) has an efficiency of $e = 0.675$ and the safe wind speed increases to 92 mph using the same number and type of mooring lines for the case of no current. This mooring has $F^* = 1703$ kips and $Fw^* = 2520$ kips.

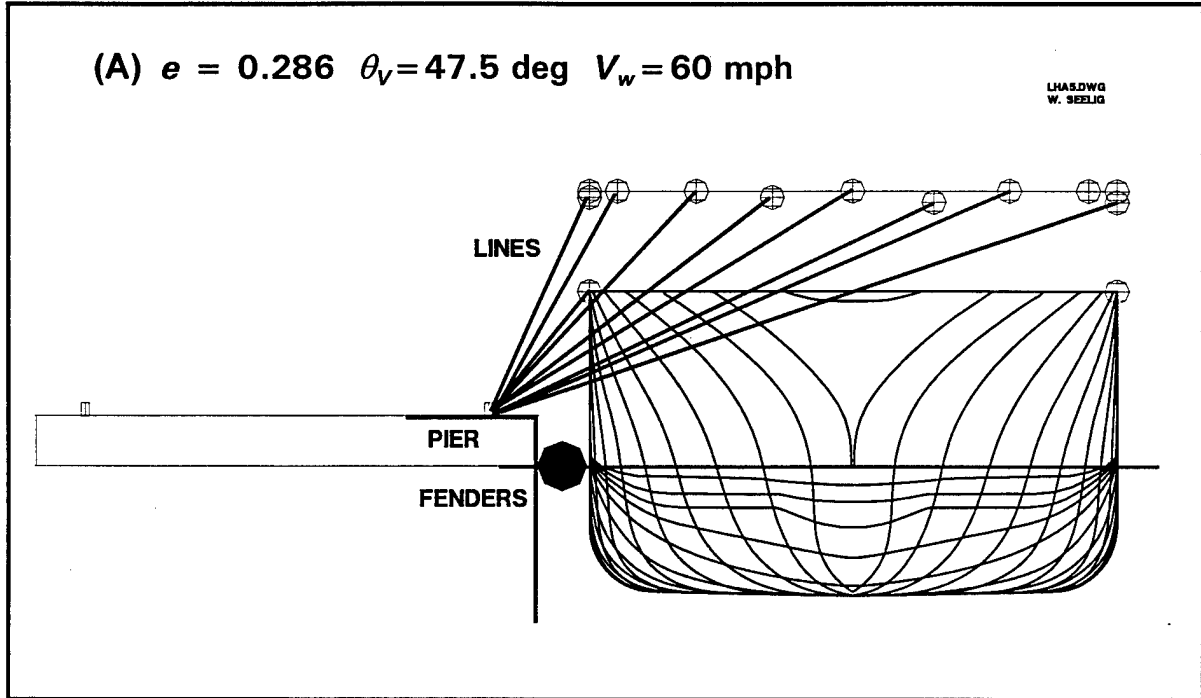

Figure 4.2 CASE (A) LHA Mooring at a Pier with Marine Fenders
(Model 5B; 14 sets of polyester lines; each line set
has a working capacity of 180 kips)

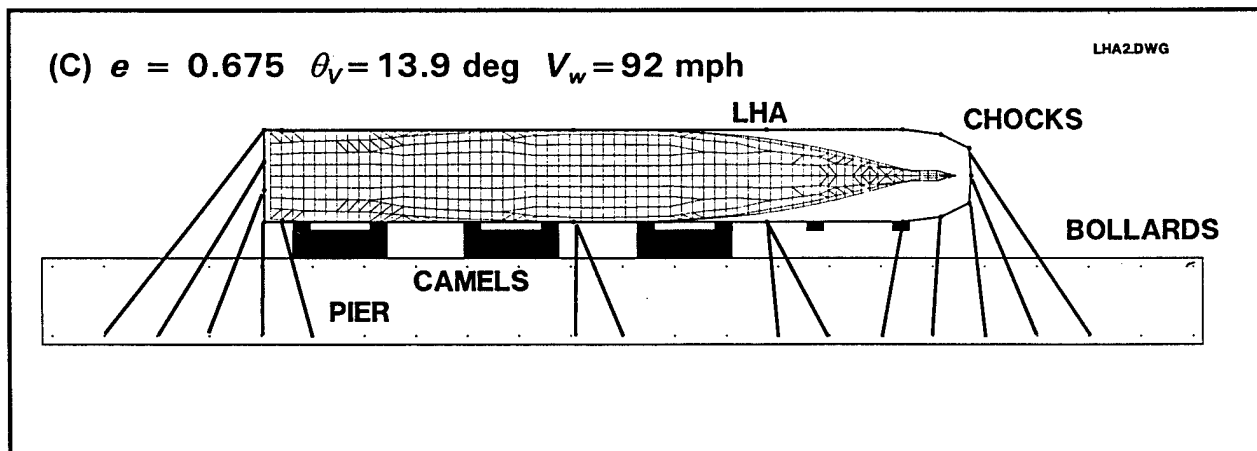
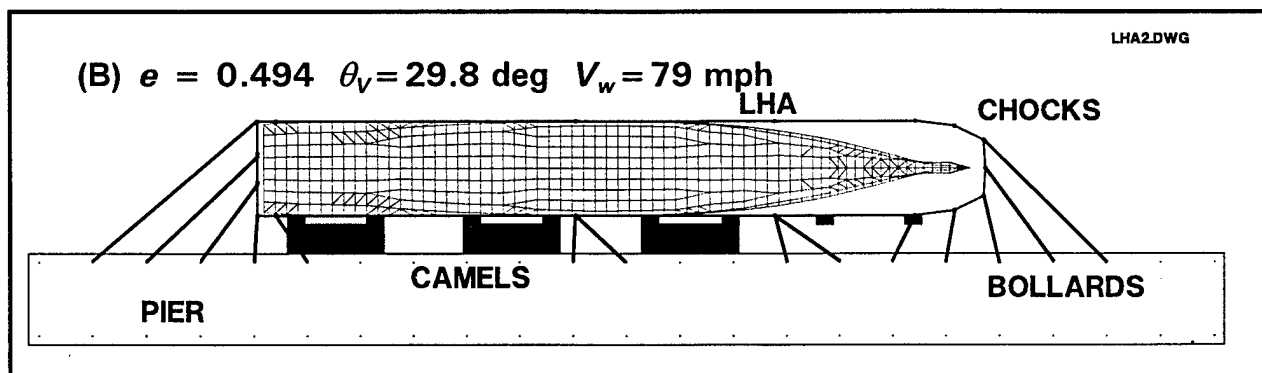
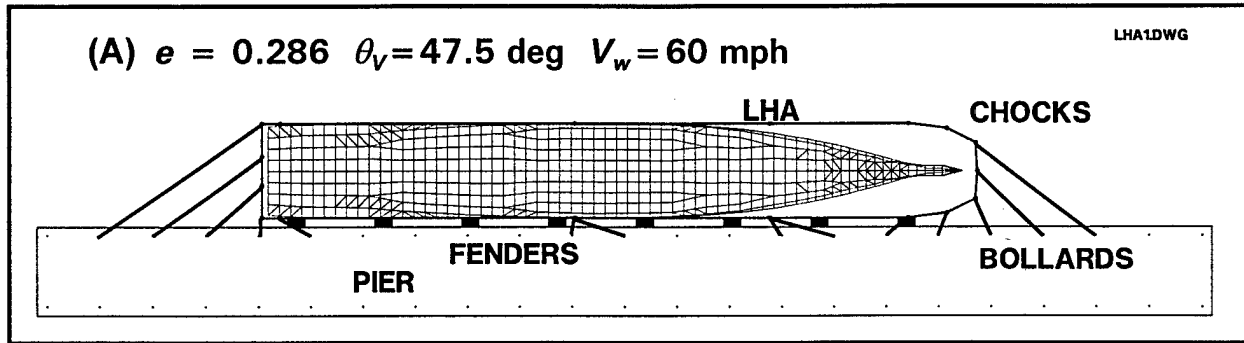

Figure 4.3 LHA Moorings Next to Pier (top), with Camels (center) and Camels and Lines Across the Pier (bottom)

(No Current)

5.0 OTHER EXAMPLES OF MOORING EFFICIENCY

Typical ship moorings at piers/wharves with synthetic lines and constant tension winches are evaluated in this section.

5.1 SHIPS MOORED WITH SYNTHETIC LINES

Examples of U.S. Navy ship moorings at a variety of piers and wharves were analyzed using methods in the DoD Mooring Manual (W. Seelig, ed., draft of 24 Dec 1997) and are summarized in Appendix A. Figure 5.1 shows mooring efficiency, e , plotted as a function of the mean vertical angle of the breasting lines, θ_v . The LHA-1 moorings described in Section 4.0 are identified in Figure 5.1. The curve shown is a lower envelope fit of typical DoD moorings that have reasonable efficiency.

CASE (O) - CVN-68 MOORING, ORIGINAL DESIGN

It is clear from a detailed analysis that some of the pier/wharf moorings analyzed could be improved. For example, aircraft carrier moorings are proposed for a new wharf. The first case examined used an existing design (Case (O) - Figure 5.2 upper). Analysis show that the original concept has rather low efficiency of $e=0.484$. In this case the horizontal and vertical angles of both the breasting and spring lines are rather poor, so that the lines are not effectively mooring the ship (W. Seelig, "Wind Effects on Moored Aircraft Carriers", NFESC TR-6004-OCN of Jan. 1998).

CASE (N) - CVN-68 MOORING, NEW DESIGN

For this proposed concept the bollards on the wharf were repositioned as shown in Figure 5.2 (lower) to improve the performance of the breasting and spring lines. This improved line arrangement increases mooring efficiency 46% to $e = 0.705$ (i.e. $((0.705/0.484)-1)*100 = 46\%$). Figures 5.2 and 5.3 show that significant improvement could be made in this aircraft carrier mooring design.

It is clear from the CVN-68 example shown above that it is possible to have rather poor mooring designs with low mooring efficiency. Detailed analyses were therefore made for each of the cases provided in Appendix A. Moorings judged to have unusually low efficiency are labeled 'Low e ' in Figure 5.1. The curve shown in Figure 5.1 is a lower envelope fit to those moorings have typical mooring efficiency.

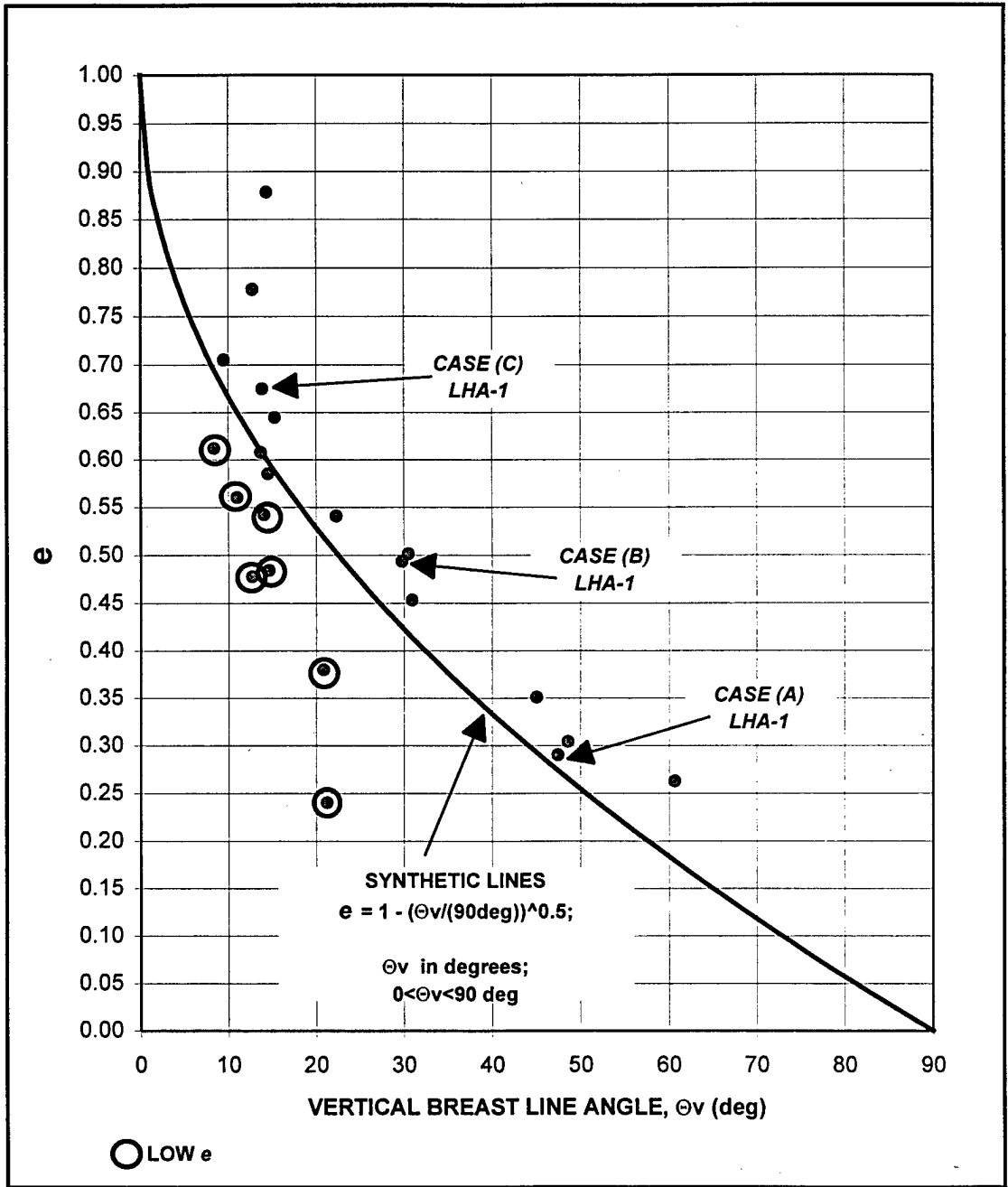

Figure 5.1 Efficiency of Ship Moorings Using Synthetic Lines

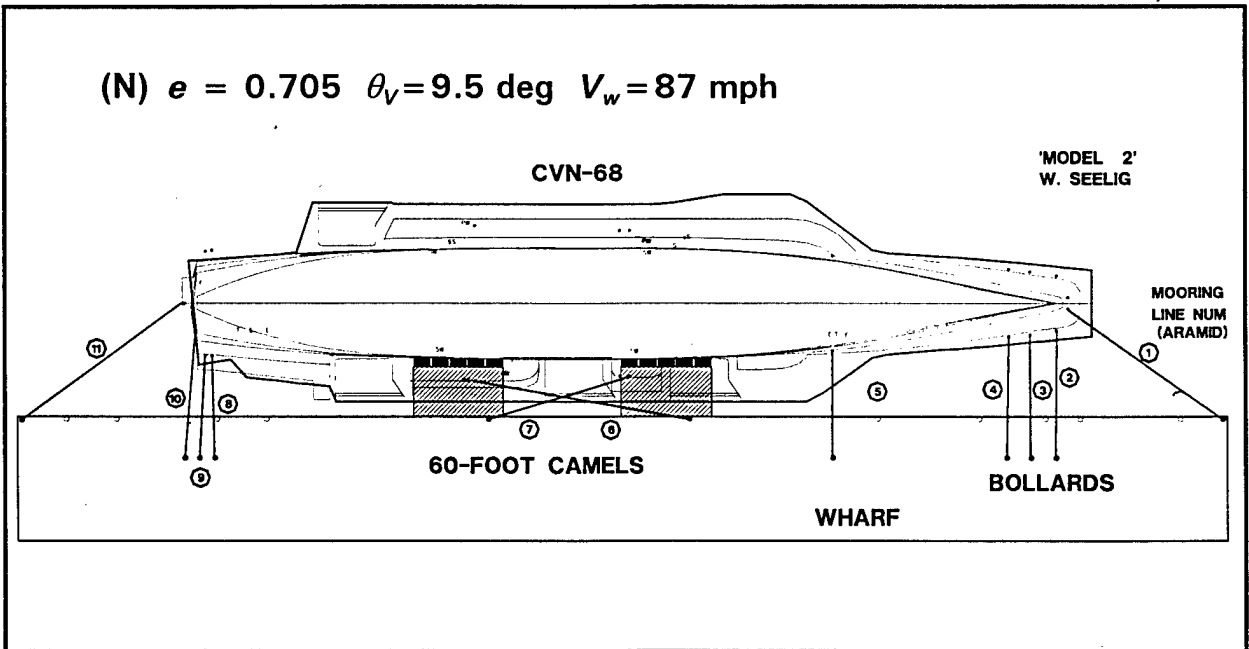
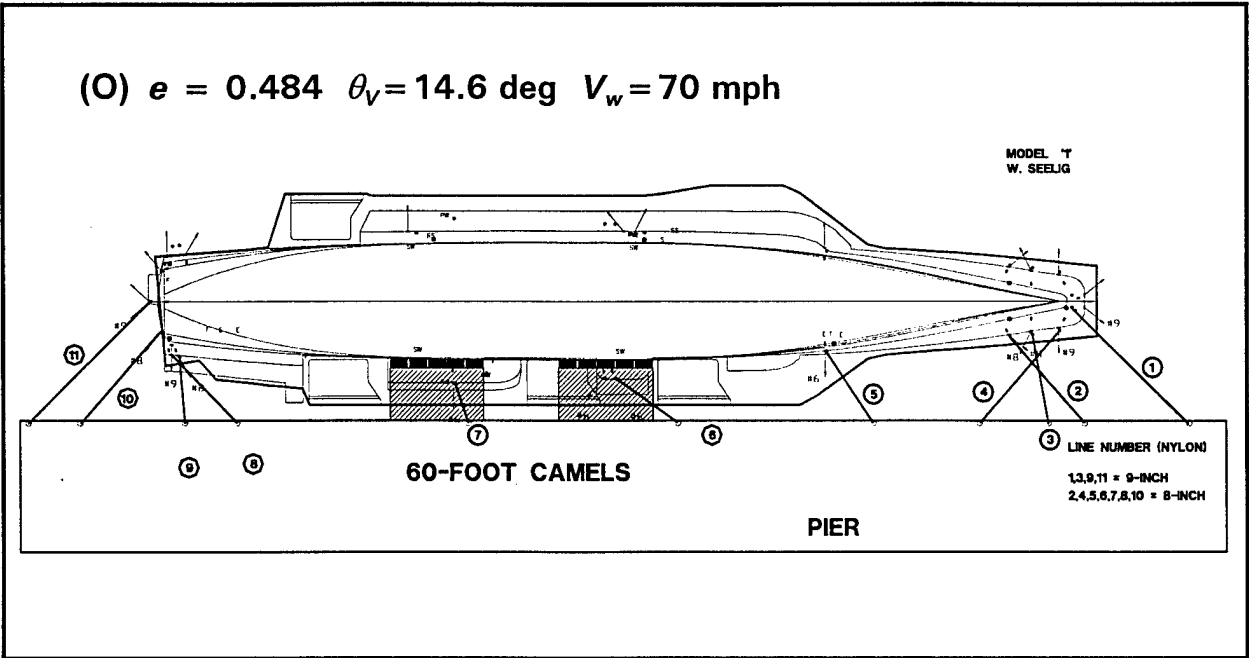

Figure 5.2 Example CVN-68 Aircraft Carrier Mooring Designs

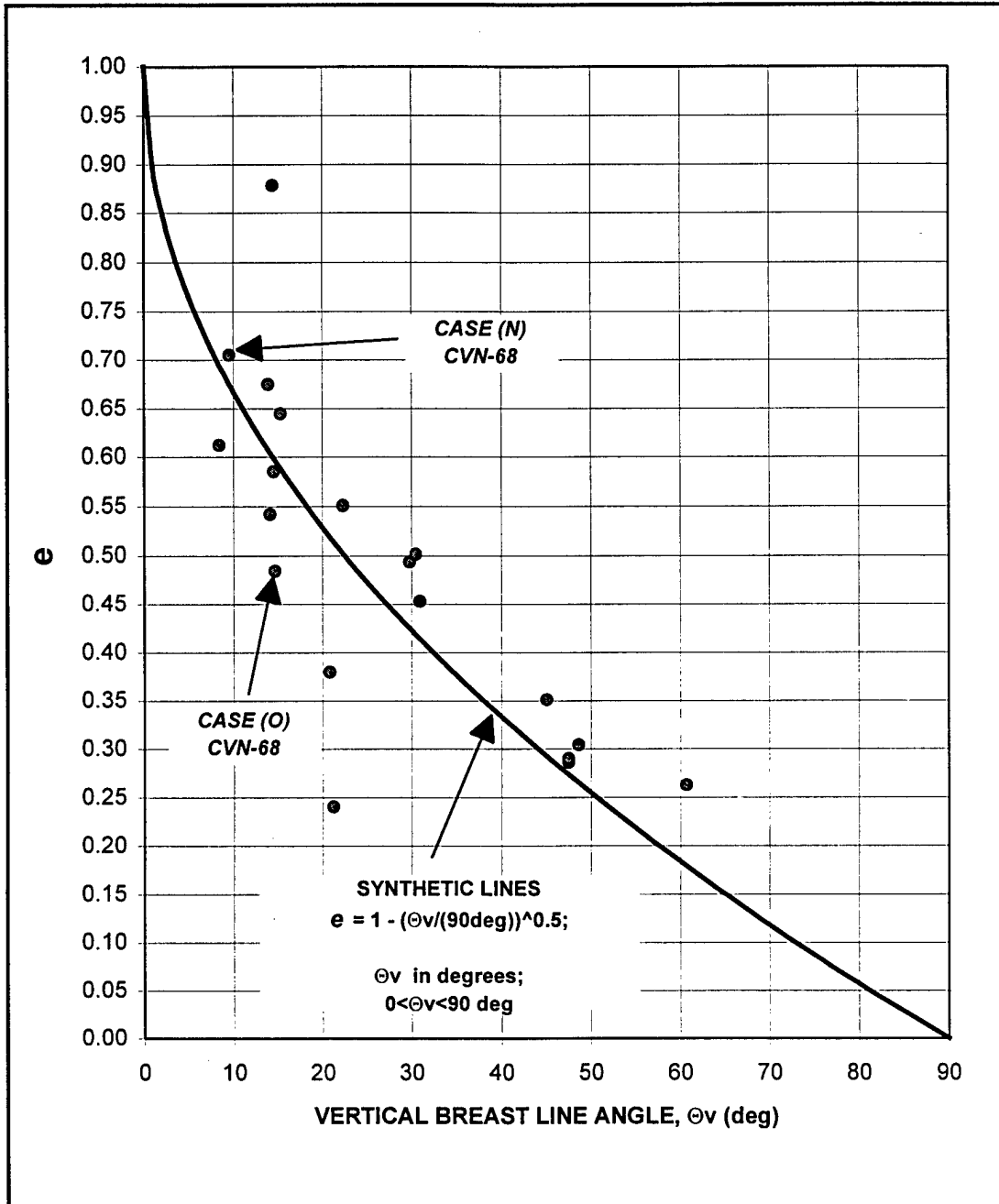

Figure 5.3 Efficiency of Ship Moorings Using Synthetic Lines

Examination of the moorings analyzed show that the average vertical breasting line angle, θ_v , is an indicator of mooring efficiency. Therefore, curves were fit to the data for those moorings using synthetic mooring lines that were found to be of good quality, based on engineering judgement. The resulting efficiency curves, as shown in Figure 5.4, for moorings using synthetic lines are:

EQUATION:

$$\text{Curve (0) "Fit"} \quad e = 1 - (\theta_v / (90 \text{ deg}))^{0.6} \quad (5-1a)$$

$$\text{Curve (1) "Lower Limit"} \quad e = 1 - (\theta_v / (90 \text{ deg}))^{0.5} \quad (5-1b)$$

WHERE:

θ_v = average vertical angle of the breasting lines (in deg)
 e = mooring efficiency

Figure 5.3 shows that decreasing the vertical angle of the breasting lines increases mooring efficiency.

5.2 SHIPS MOORED WITH CONSTANT TENSION WINCHES

A constant tension winch is a device that keeps a steady load on a mooring line. Wire rope is one of the more common tension members used. Some of the advantages of constant tension winches are: (1) the load sharing between mooring members is improved, (2) there is less possibility of a mooring line being overloaded, and (3) a smaller crew is needed to moor a ship. Some of the disadvantages of constant tension winches are: (1) the initial cost is high, (2) maintenance cost can be high, (3) they add weight to the ship, and (4) and they are much more complex than a set of bitts.

In the past warships have tended to use mooring bitts, while commercial ships use either constant tension winches, bitts or a combination of both. If constant tension winches are used it is wise to put out several synthetic mooring spring lines to keep the ship from 'walking' down the pier.

Examination of Figure 5.4 shows that moorings with constant tension winches tend to be more efficient than moorings with synthetic lines for a given average vertical mooring line angle, primarily because constant tension winches provide better load sharing. Efficiency of moorings with constant tension winches can be estimated, as shown in Figure 5.4, from:

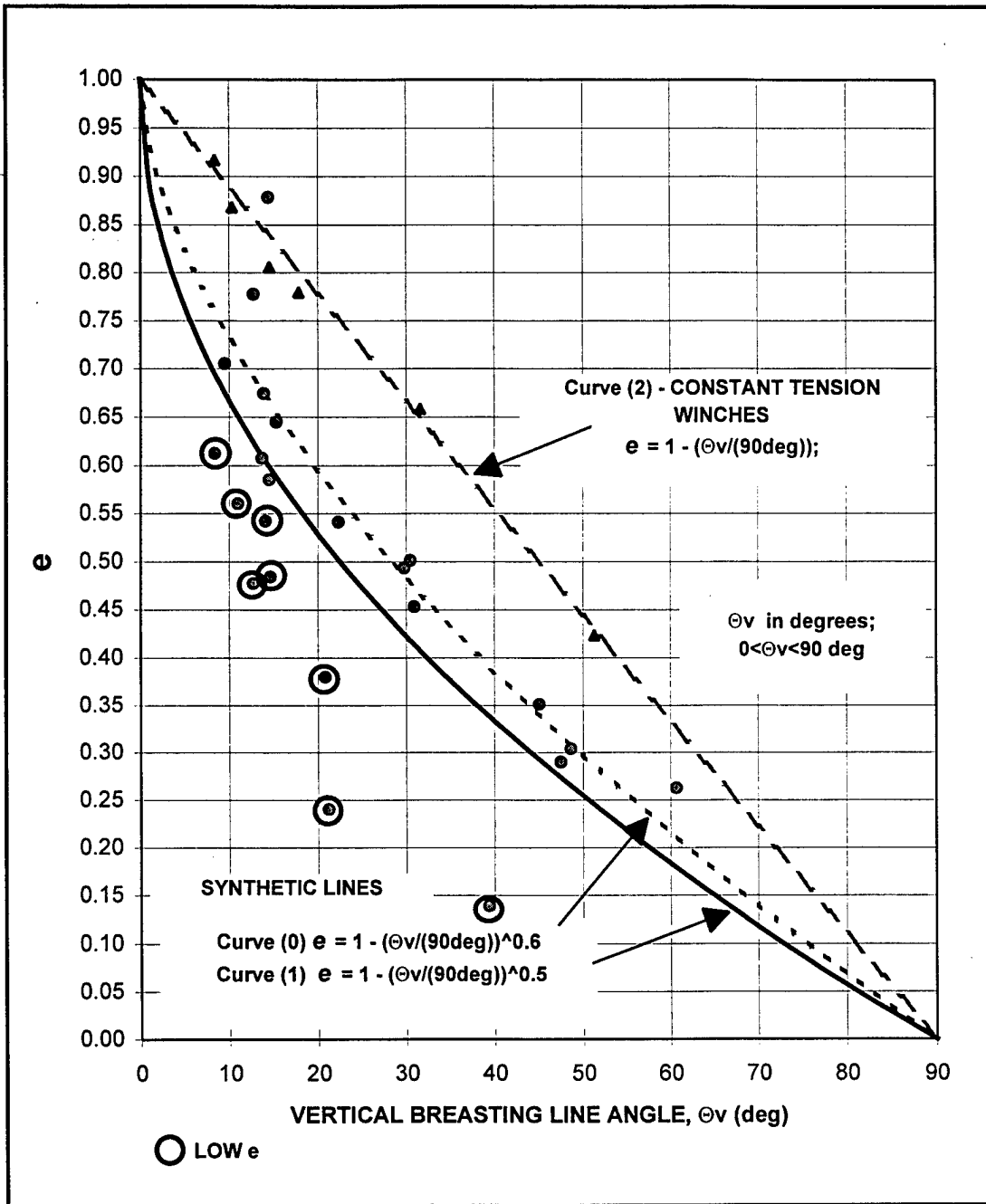

Figure 5.4 Efficiency of Ship Moorings at Piers and Wharves

EQUATION:
$$e = 1 - (\theta_v / (90 \text{ deg})) \quad (5-2)$$

WHERE:

θ_v = average vertical angle of the breasting lines (in deg)
 e = mooring efficiency

5.3 MOORING FACTOR, r

Mooring efficiency, e , can be thought of as a dimensionless measure of how well a given set of mooring lines is resisting environmental forces and moments on a ship. Environmental forces and moments due to winds and currents increase as the square of the wind or current speed for a given direction. Therefore, mooring efficiency, e , is not a linear indicator of how improving efficiency for a mooring with a given set of mooring lines improves the safe environmental limits.

The mooring factor, r , is a dimensionless measure of how the maximum safe environmental mooring limits change as mooring efficiency changes for a mooring with a given set of lines where the mooring factor, r , is:

EQUATION:
$$r = e^{0.5} \quad (5-3)$$

WHERE:

e = mooring efficiency
 r = mooring factor

Figure 5.5 shows values of r for mooring systems with synthetic line and constant tension winches. The parameter r can be used, for example, to show how the safe environmental limits change as the vertical breasting line angle changes.

As an example, take the case of ship moored to a pier with a number of synthetic mooring lines at an average vertical breasting line angle of $\theta_v = 20$ degrees. Table 5.1 compares a mooring using the same number of constant tension winches with the same working capacity as the synthetic lines.

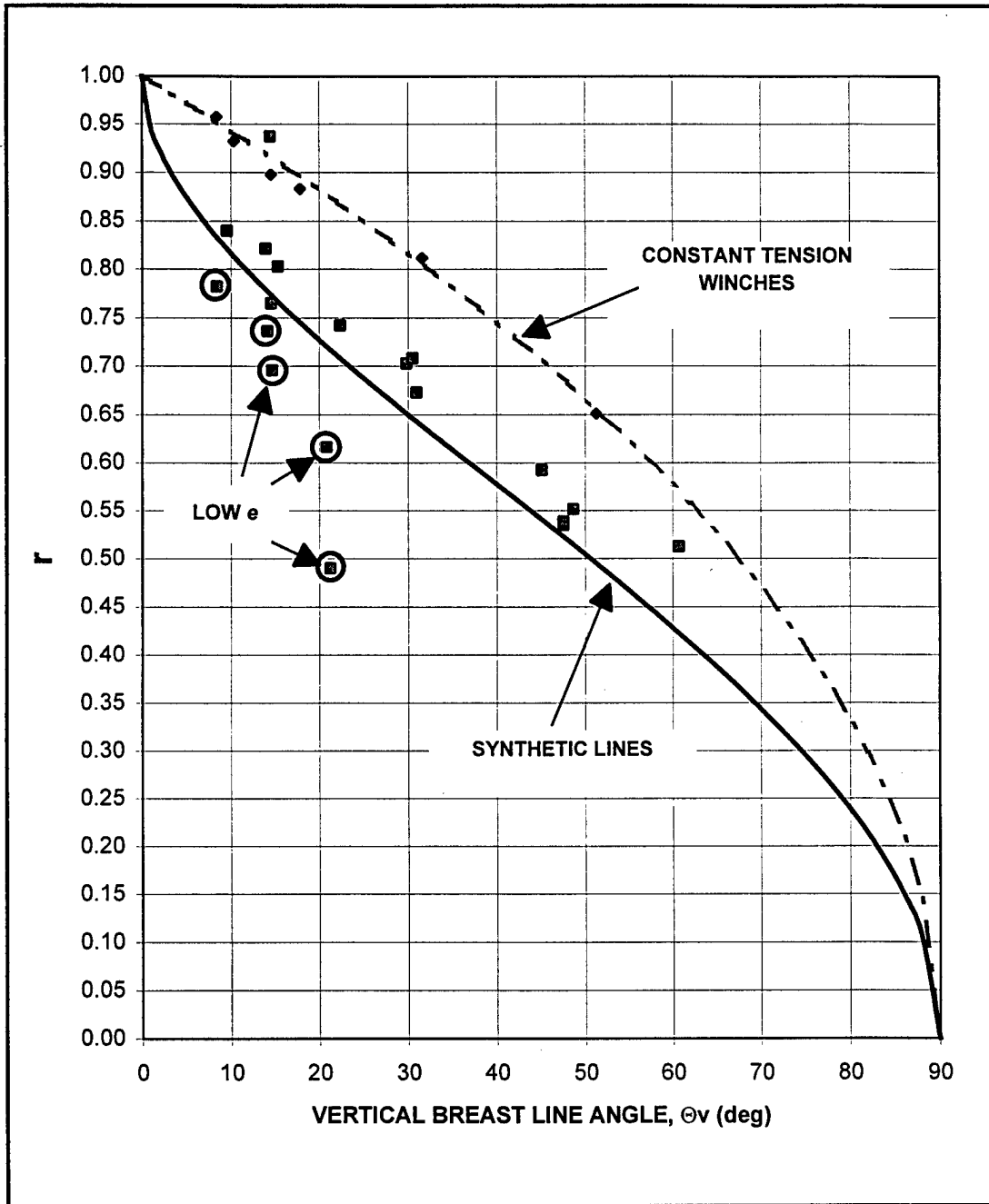

Figure 5.5 Mooring Factor, r

Table 5.1 Example with $\theta_v = 20$ degrees Comparing Moorings with Synthetic Lines and Constant Tension Winches

<i>Mooring Type</i>	<i>e</i>	<i>r</i>
synthetic lines	0.5286	0.7270
constant tension winches	0.7778	0.8819
% difference	+47%	+21 %

In this example constant tension winches are predicted to be 47% more efficient than a mooring with synthetic lines. For this example, if the ship were moored in only winds then a mooring with constant tension winches would be estimated to be safe in 21% higher winds than a similar mooring with synthetic lines.

As another example take a ship pier mooring with synthetic mooring lines and show the effect of reducing the average vertical breasting line angle, θ_v , from 40 to 20 degrees. Table 5.2 shows that reducing the average vertical breasting line angle increases the safe wind speed by approximately 26 % for the case of no current.

Table 5.2 Example with $\theta_v = 20$ and 40 degrees for a Mooring with Synthetic Lines

Average Breasting Line Vertical Angle	<i>e</i>	<i>r</i>
$\theta_v = 40$ degrees	0.3333	0.5774
$\theta_v = 20$ degrees	0.5286	0.7270
% difference	+59 %	+26 %

These examples show how improving mooring efficiency, *e*, also improves the mooring factor, *r*. Practical experience with design of moorings for extreme environmental conditions shows that even a modest improvement of design may dramatically reduce risk, due to the non-linear probability distribution of extreme events.

METHOD APPLICATION

Sections 6.0, 7.0 and 8.0 show how the methods in this report are used and Section 9.0 provides summary and conclusions.

6.0 PLANNING/PRELIMINARY DESIGN

6.1 NEED

The planner/designer of a mooring generally knows some of the parameters shown in Table 6.1 and needs to determine the remaining parameters. Or in some cases, all the parameters are known and a planning/preliminary design check is required. This report provides a simple tool for planning/preliminary design.

Table 6.1 Parameters in a Mooring Project

<i>PARAMETER</i>	<i>EXAMPLES</i>
1. Operational Parameters	Required ship position, amount of motion allowed
2. Ship Configuration	Basic ship parameters, such as length, width, draft, wind areas, mooring fitting locations, wind/current force and moment coefficients
3. Facility Configuration	Facility location, water depth, dimensions, locations/type/capacity of mooring fittings/fenders, facility condition, facility overall capacity
4. Environmental Parameters	Wind speed, current speed, water levels, wave conditions
5. Mooring Configuration	Number/size/type/location of tension members, camels, etc.
6. Material Properties	Stretch/strain characteristics of the mooring tension and compression members

6.2 APPROACH

Solving for the behavior of a ship moored at a pier or wharf can be somewhat complex. Therefore, the approach taken in this report is: (1) solve for mooring requirements in terms of a simple mooring, and (2) calibrate the simple calculations via the concept of mooring efficiency using detailed analyses of typical DoD moorings.

The number of mooring lines required to safely moor a ship in a given environment is the sum of mooring working line capacities divided by the working capacity for one part of mooring line. The working capacity of a mooring line is equal to the line break strength of the line divided by the factor of safety. Here a factor of safety of 3 is used.

The sum of all the mooring line working capacities, Fw^* , required to safely moor a given ship in a given environment is given by equation (6-1).

EQUATION:
$$Fw^* = F^* / e \quad (6-1)$$

WHERE:

Fw^* = the sum of mooring line working capacities
for an actual mooring

F^* = sum of mooring line working capacities
for the optimum ideal mooring

e = mooring efficiency

F^* is easily solved, as shown in Section 3.2. Therefore, the only unknown is mooring efficiency, e .

One way to estimate mooring efficiency, e , is to use Figure 6.1. Curve (0) is a fit through the data for good quality moorings using synthetic lines, Curve (1) is a lower envelope fit through good quality moorings using synthetic lines and Curve (2) is a line fit through the data for moorings using constant tension winches.

Solving for the number of mooring lines using F^* and e is easy, so a spread sheet 'EMOOR98' is provided that performs the necessary calculations.

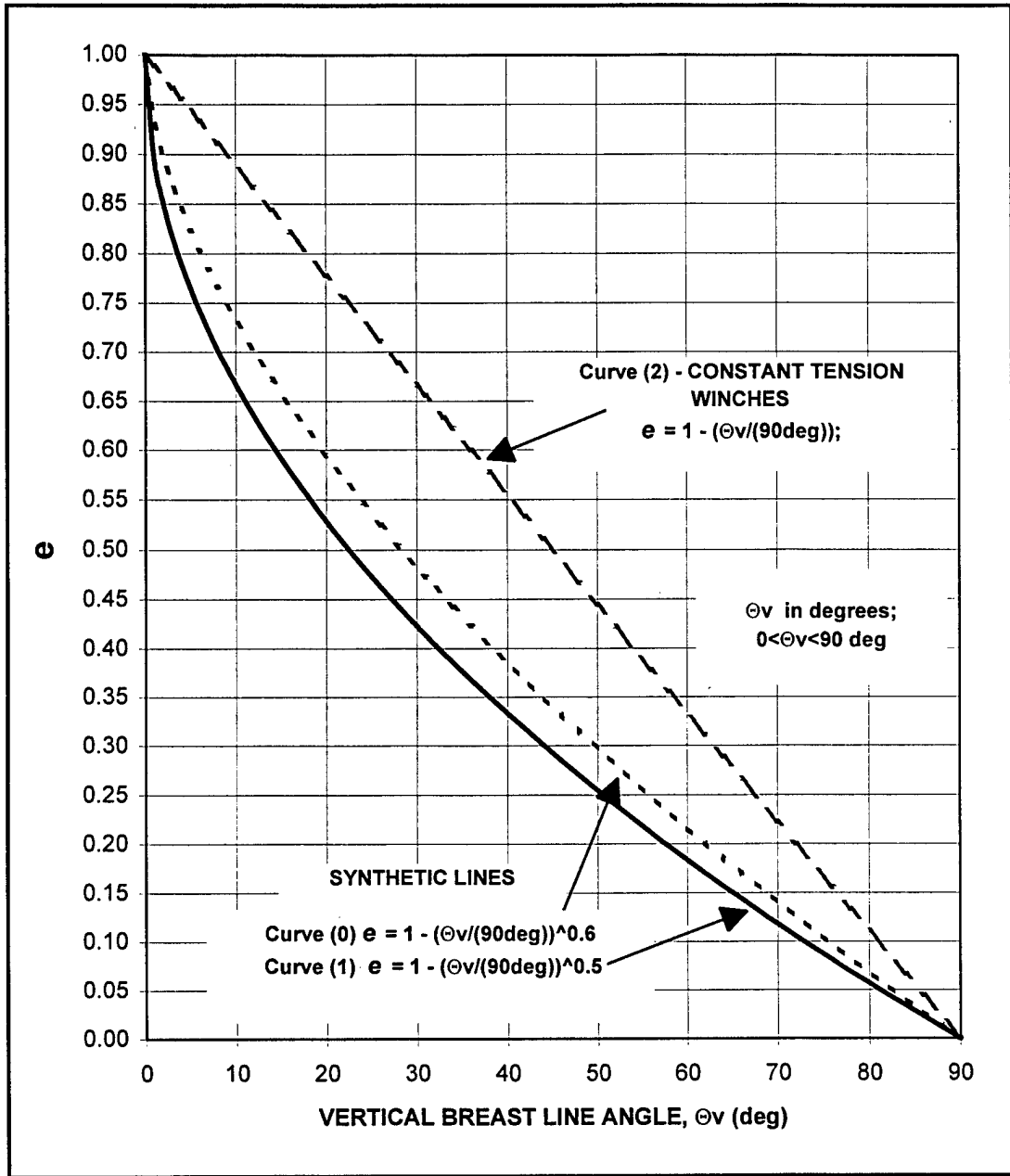

Figure 6.1 Mooring Efficiency Curves for Mooring at Piers and Wharves

7.0 EMOOR98

EMOOR is a computer program which performs the calculations described in this report. This program is intended for planning or preliminary designs of ship moorings at piers and wharves. EMOOR is not intended to be used as a final design tool.

EMOOR performs the following calculations: (1) solves for the optimum ideal mooring for a given ship in a given set of environmental conditions, (2) determines mooring efficiency from Figure 6.1, and (3) estimates the minimum number of mooring lines are required.

EMOOR98 is a test version that is provided in spread sheet form. Table 7.1 is a sample that illustrates input and output. The first row of the spread sheet shows the column identifying letter. The first column in the spread sheet shows the row number. There are several sections to the spread sheet. Each section is identified by bold italic text. Sections are described below.

(A) SHIP COEFFICIENTS (Columns E and higher)

These are various ship parameters, drag coefficients, force coefficients and dimensionless wind moment arms. These are determined from methods in "DoD Mooring Manual" (W. Seelig, ed., MIL-HDBK 1026/4, draft of 24 Dec 1997). Note that SI (i.e. metric) units are used for the coefficients.

Columns *E* and *F* are the 'on deck' columns, where the information on the ship being analyzed are placed. Columns *J* and beyond provide this information for a variety of DoD ships. Note that in some cases different columns are used for various draft conditions for the same class ship.

Scroll through Columns *J* and beyond to find the ship/draft you are interested in, then copy that information to the 'on deck' Columns *E* and *F*.

(B) DATA TO ENTER (Column C, Rows 6 through 13)

Data to enter into the spread sheet is included in this section. Note that EMOOR98 at this time is set up to analyze only cases of a current parallel or perpendicular to the ship. The spread sheet is now set up to use U.S. Customary units in this section.

Note that the water depth (Column *C*, Row *6*) should be greater than the ship draft.

Table 7.1 Sample EMOOR98.XLS Spread Sheet

1/A	B	C	D	E	F
2	EMOOR98.XLS			(A) SHIP COEFFICIENTS	
3	W. SEELIG NFESC 551 202-433-2396			LHA-1 LOADED	
4	16-Mar-98			T Ship Draft (ft)=	26
5	(B) DATA TO ENTER			LwL (ft)=	765
6	Water Depth (ft)=	40.0		Co Deepwater Drag Coeff=	0.716
7	Current Speed END-ON (knots)=	0.00		C1 Shallow Water Drag Coeff=	3.2
8	Current Speed BROADSIDE (knots)=	0.00		Cd Drag Coeff=	1.77
9	Wind Speed (mph)=	60.00		cxw @0 deg (N/(m/s)^2)=	243.88
10	Vertical Angle of Breast Lines (deg)=	20		cyw @90deg (N/(m/s)^2)=	3640.87
11	Line Break Strength (kips)=	221		cxc@0deg (N/(m/s)^2)=	5.74E+04
12	Pier Blockage Factor (1.0 recommended)=	1		cyc@90deg (N/(m/s)^2)=	1.67E+06
13	Mooring Type (0=syn. lines "fit"; 1=syn. lines "lower limit	1		WIND	WIND
14	2=constant tension winches)			ANGLE	MOMENT
15	(C) OUTPUT	T/d=	0.65	(deg)	ARM (e/L)
16		F* (kips) =	721.791	15	-0.1703
17	MOORING EFFICIENCY =	e =	0.529	30	-0.1307
18	REQD SUM OF LINE BREAK (kips) =	4096		45	-0.0966
19	MINIMUM NUM PARTS OF LINE REQUIRED* =	20		60	-0.0683
20	MIN NUM PARTS BREASTING LINE REQD** =	16		75	-0.0376
21	MIN NUM PARTS SPRING LINE REQD** =	4		90	0.0000
22	BROADSIDE FORCE (kips) =	588.9		105	0.0398
23	*rounded up to nearest value of 2			120	0.0723
24	** minimum of 2 required			135	0.1023
25	*** FS = 3.0 used			150	0.1384
26				165	0.1803

Pier Blockage Factor (Column **C**, Row **12**) is a multiplying factor that can be used to reduce lateral forces and moments and can be used to account for reduced forces due to pier blockage of the wind. A value of 1.0 is generally recommended, which means that the pier or wharf is not providing any blockage to the wind.

Cell Column **C**, Row **13** identifies the mooring type. Use "0" to get a fit through the data for moorings with synthetic lines, use "1" for a lower limit of moorings with synthetic lines and use "2" for moorings with constant tension winches.

(C) OUTPUT (Column C, Rows 15 through 22)

Row	Description
15	T/d = ship draft divided by water depth
16	F^* = computed sum of required mooring line working tension capacities for the optimum ideal mooring
17	Mooring efficiency, e , estimated from Figure 6.1
18	Estimated required sum of line break strength = $FS * (F^*/e)$; factor of safety $FS = 3.0$ is used
19	Minimum parts of line required = Estimated required sum of line break strength divided by the line break strength (Note: rounded up to the nearest value of 2)
20	Minimum number of parts of breasting lines (Note: rounded up to the nearest value of 2)
21	Minimum number of parts of spring lines (Note: rounded up to the nearest value of 2)
22	Broadside force (Gives an estimate of required overall pier capacity)

(D) SUPPORTING CALCULATIONS (not shown in Table 7.1)

Various supporting information is provided in this section.

(F) OPTIMUM IDEAL CALCULATIONS (not shown in Table 7.1)

Calculations for the optimum ideal mooring are made in this section. A sample of these calculations is worked step-by-step in Section 3.2 of this report.

NOTES

EMOOR98 gives an estimate of the minimum number of mooring lines required to secure a given ship in a given wind and current. These calculations are based on calibration of mooring efficiency using actual moorings and the curves shown in Figure 6.1. Here the moorings are assumed to have typical mooring efficiency. Some key features of efficient moorings are:

- (1) Horizontal angles of breasting lines are near 90 degrees to efficiently resist transverse forces and moments.
- (2) Horizontal angles of spring lines are small to effectively hold the ship in the longitudinal direction.
- (3) Breasting lines all have similar stiffness for reasonable load sharing between mooring lines.
- (4) Lines have similar pretensions.
- (5) The proper mixture of spring and breasting lines is used.

If a mooring design has efficiency lower than the curve shown on Figure 6.1, then additional mooring lines over and above the minimum may be required. The cases in Appendix A show mooring designs to illustrate values of mooring efficiency. Some 'LOW e' designs moorings are:

- (1) Figure A-6. Breasting Line 4 is less than half the length of the other breasting lines, so it takes a relatively large proportion of the mooring load for some wind directions.
- (2) Figure A-7. The horizontal angles of lines are such that neither breasting or spring lines are very efficient at holding the ship.
- (3) Figure A-9. Breasting Lines 2 and 5 are very short and stiff, so they take a high proportion of the mooring load.
- (4) Figure A-11. The vertical and horizontal line angles are large, due to the poor relative placement of fittings on the pier and ship, leading to over all low mooring efficiency.

8.0 EXAMPLES

Some examples of how EMOOR98 can be used include:

EXAMPLE 1. The ship, facility and mooring configuration are known. The safe environmental limits for the mooring lines are then found by increasing the wind and current speeds until the number of mooring lines predicted by EMOOR98 in cell D19 matches the mooring plan.

EXAMPLE 2. The ship, facility and mooring configuration are known. The safe environmental limits for the pier are then found by increasing the wind and current speeds until the broadside force predicted by EMOOR98 in cell D22 matches the lateral working capacity of the pier.

EXAMPLE 3. The ship, facility and environment are known. The number of mooring lines required is estimated by EMOOR98 cell D19.

EXAMPLE 4. The ship, facility, environment and number of mooring lines are known. The maximum mean vertical angle of the breasting lines is estimated by trial and error by entering in various angles in EMOOR98 cell C10. If the number of mooring lines estimated in EMOOR98 cell D19 is less than or equal to the actual number of lines, then the vertical breasting line angle input in cell C10 is adequate. The vertical breasting line angle is then used to estimate the location of pier fittings and/or camel width.

9.0 SUMMARY AND CONCLUSIONS

The following are provided in this report:

(1) Development of the concept of an optimum ideal mooring. Key features of this idealized mooring are:

- (a) The basic mooring requirements for a ship with a given set of environmental parameters in an optimum ideal mooring can be analyzed with use of a simple free-body diagram.
- (b) Results from the optimum ideal mooring analysis provide a basis for evaluating realistic moorings.

(2) Generalized study of simple mooring systems. Results of this analysis show the relative importance of various parameters, such as the horizontal and vertical angles of breasting lines, on mooring performance.

- (3) Definition of mooring efficiency, e . This is a simple non-dimensional parameter that measures how effectively mooring lines are being used to moor a ship at a pier or wharf.
- (4) Definition of mooring factor, r . This is a simple non-dimensional parameter that gives an indication of the relative change in the safe working wind or current limits as the design of a given mooring system is changed.
- (5) Evaluation of a wide range of actual DoD ship moorings at piers and wharves. Determination of mooring efficiency, e , for actual mooring of a variety of DoD ships at a number of berths around the world shows:
- (a) The average vertical angle, θ_v , of the breasting lines is the single most important parameter influencing mooring efficiency. As this angle decreases, the efficiency of a mooring increases.
 - (b) Moorings with constant tension winches are more efficient than ships moored with synthetic lines at a given average vertical mooring line angle, because constant tension winches have better load sharing between various tension members. Methods in this report can be used to help evaluate the relative merits of the two different types of mooring systems.
- (6) Examples are worked to show how the concepts presented in this report can be used to improve mooring design, improve ship safety and reduce risks to moored ships.
- (7) Development of a planning/preliminary design tool, EMOOR. A test version of this program, EMOOR98, is provided with this report. This program provides information, such as:
- Required overall pier/wharf capacity
 - Required number of pier/wharf fittings
 - Required pier/wharf pier fitting capacity
 - Number of spring lines required, and
 - Number of breasting lines required

for a given ship under a specified set of environmental conditions.

At the present time (March 1998) 26 ship classes are loaded into EMOOR98.

Point of contact at this Command is:

NAME:	Mr. Bill Seelig
PHONE:	202-433-2396
FAX:	202-433-5089
EMAIL:	wnseelig@efaches.navfac.navy.mil

REFERENCES

Seelig, W., "Wind Effects on Moored Aircraft Carriers," Naval Facilities Engineering Service Center, Technical Report TR-6004-OCN, Jan. 1998.

Seelig, W., ed., "DoD Mooring Manual," MIL-HDBK-1026/4, Naval Facilities Engineering Command, draft of 24 Dec 1997.

NOTATION

- e = mooring efficiency
- F^* = sum of mooring line working capacities for the optimum ideal mooring
- F_w^* = sum of mooring line working capacities for an actual mooring
- F_b = line breaking strength
- F_x = force on the ship in the longitudinal axis
- F_y = force on the ship perpendicular to the longitudinal axis
- FS = factor of safety
- i = mooring line number
- L = ship length
- M = moment
- N = number of mooring lines
- r = mooring factor = square root (e)
- T_i = tension in Line i
- V_w = wind speed
- X = x-distance of breasting line attachment point from midships
- x = distance along ship longitudinal axis
- y = distance perpendicular to the ship longitudinal axis
- z = distance above ship's keel
- θ_H = horizontal breasting line angle
- θ_V = vertical breasting line angle
- θ_w = wind direction

APPENDIX A. SAMPLE MOORINGS

Sample moorings with their computed efficiencies are shown in plan view in this appendix. Those mooring with unusually low efficiencies are labeled "**LOW e**".

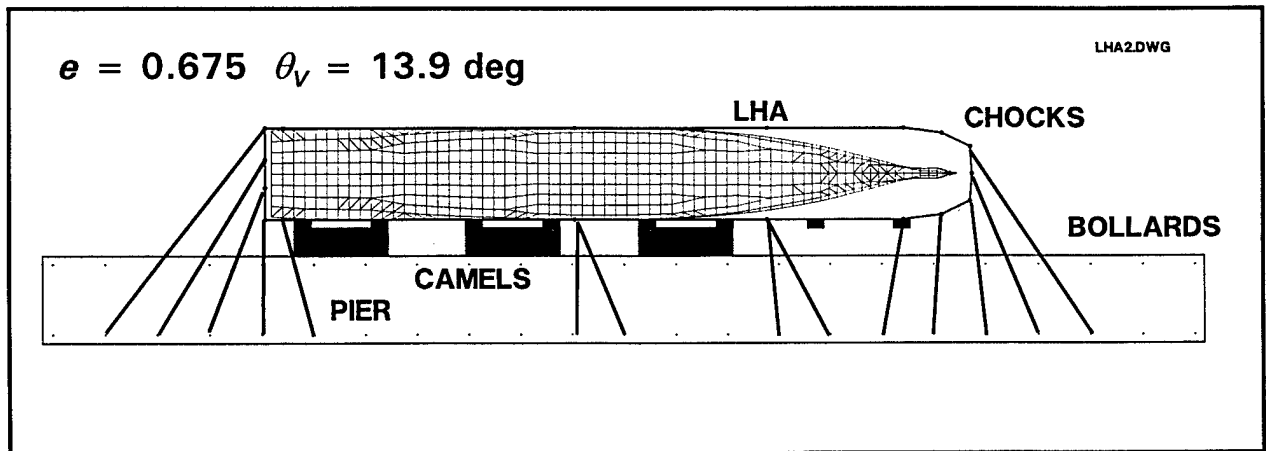
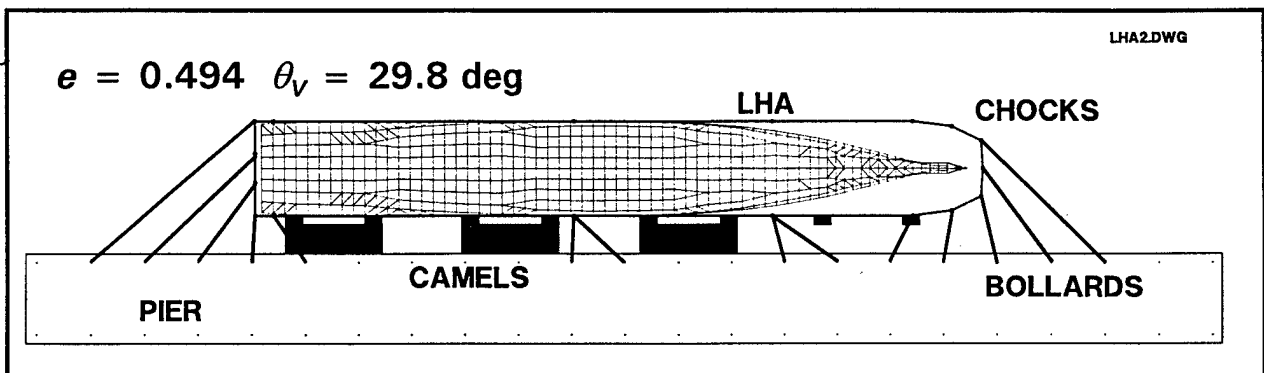
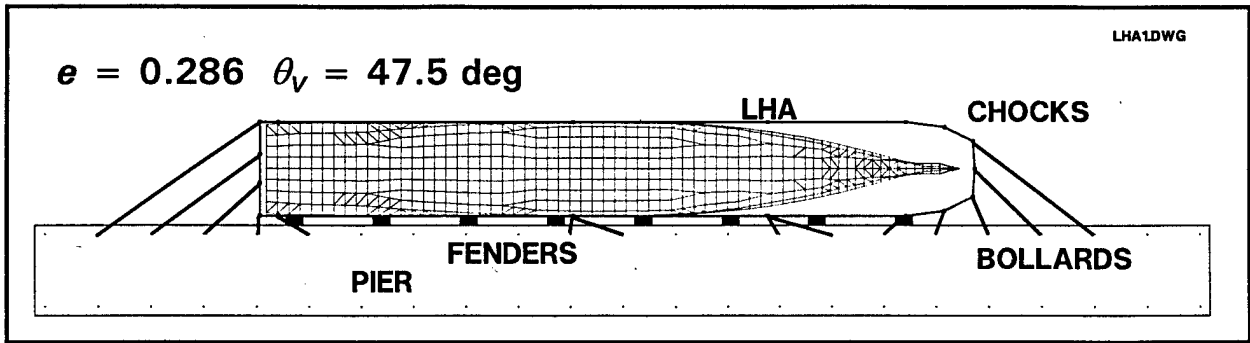

Figure A-1. LHA-1 Moorings Next to Pier (top), with Camels (center) and Camels and Lines Across the Pier (bottom)

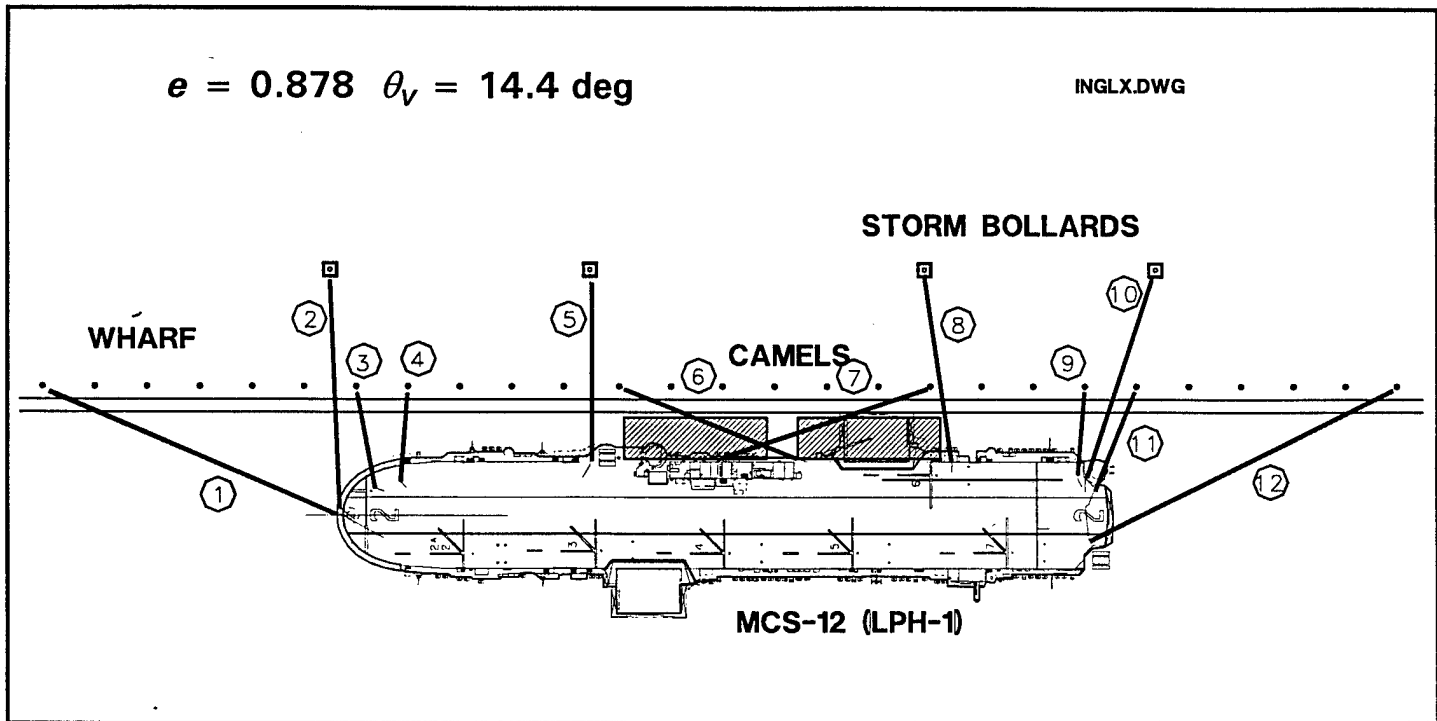

Figure A-2. MCS-12 (LPH-1) Moored at Naval Station, Ingleside, TX

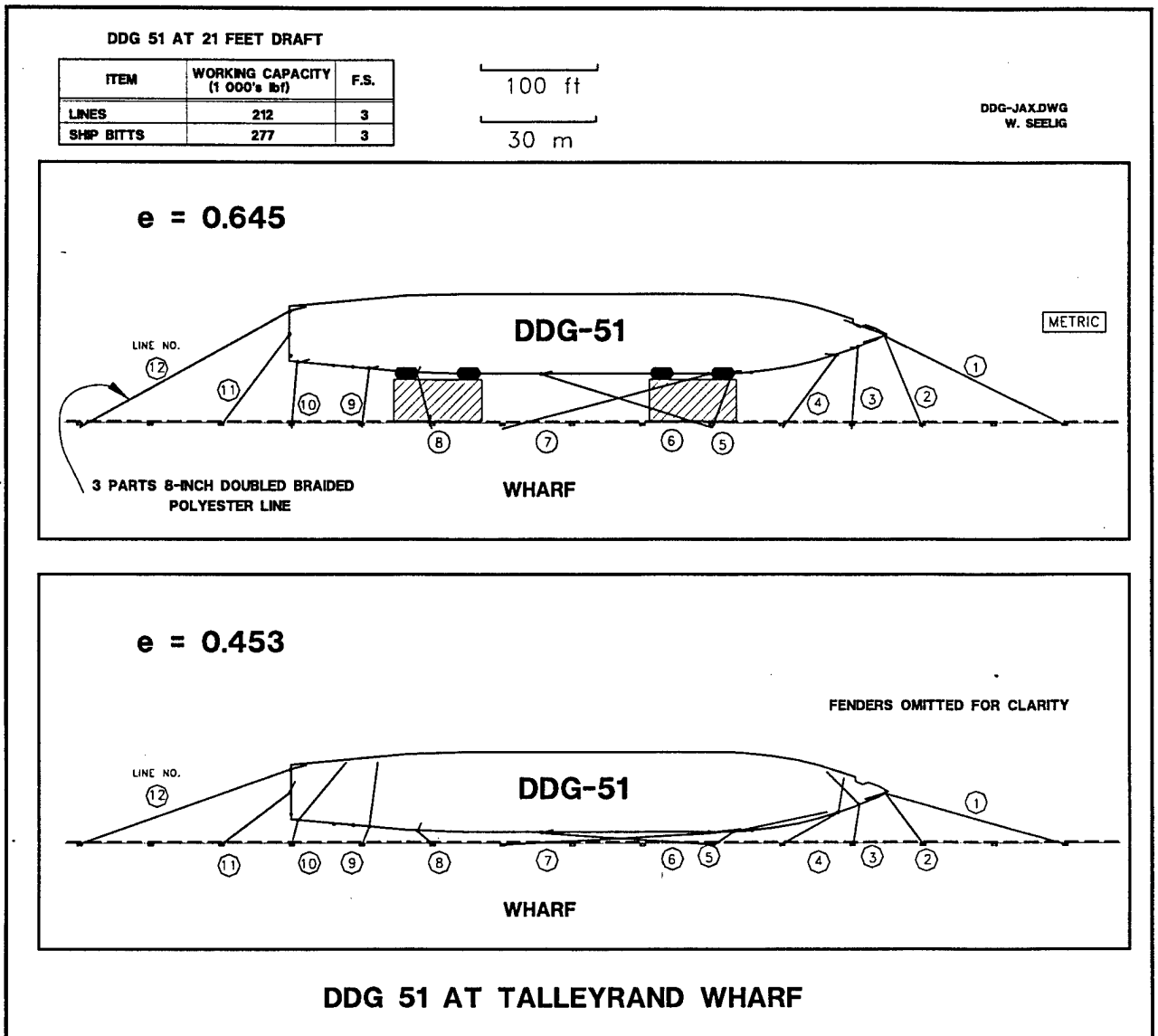

Figure A-3. Efficiency of Mooring a DDG-51 to a Pier
With Camels (Top $\theta_v = 15.3$ deg)
and Without Camels (Bottom $\theta_v = 30.9$ deg)

(Note that for the case without camels, the lines have been
run across the deck when possible to increase the line
stretch and improve load sharing between lines)

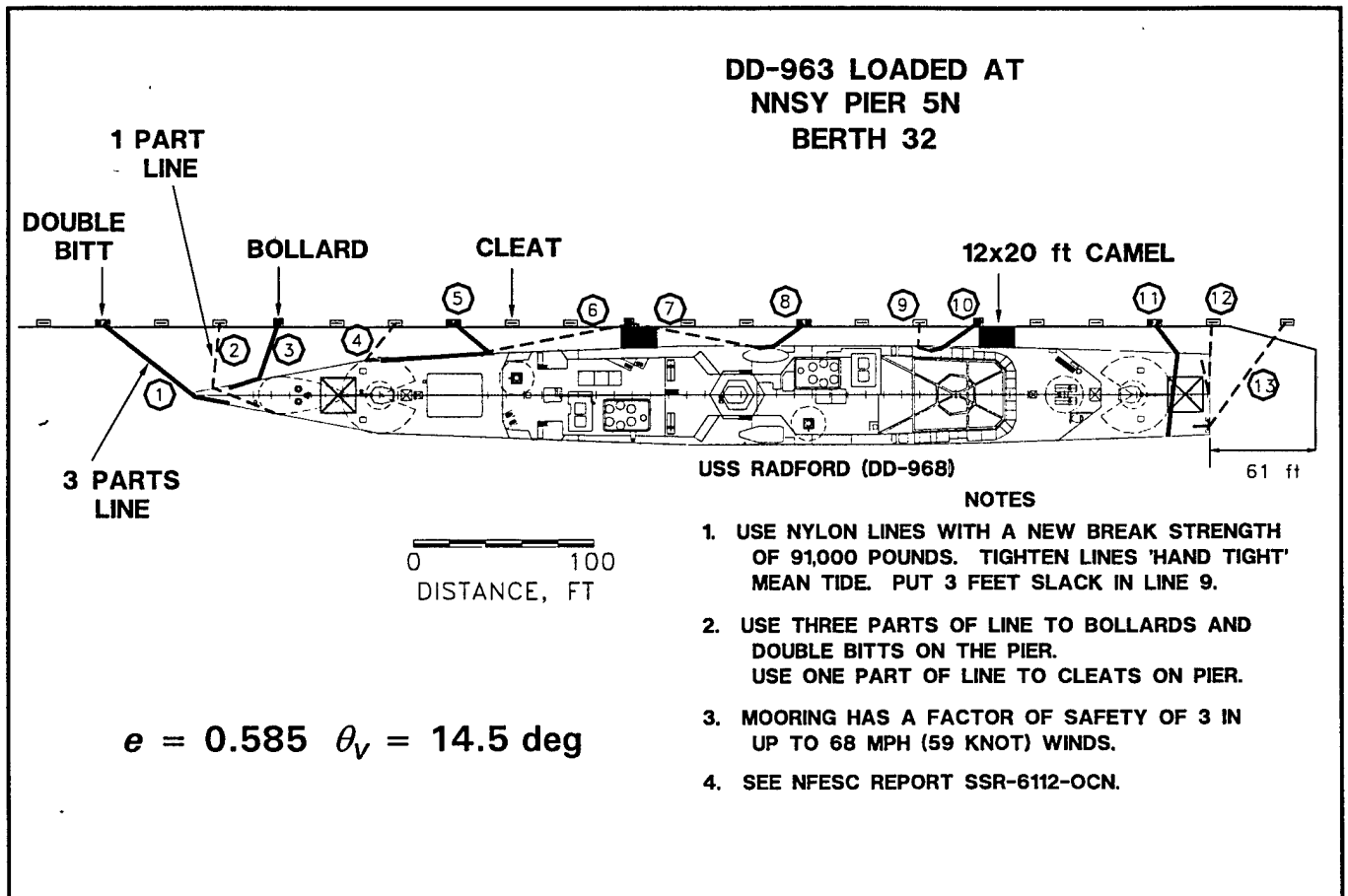

Figure A-4. Efficiency of Mooring a DD-963 to a Pier
With 12-Foot Camels

(Note that the lines have been
run across the deck when possible to increase the line
stretch and improve load sharing between lines)

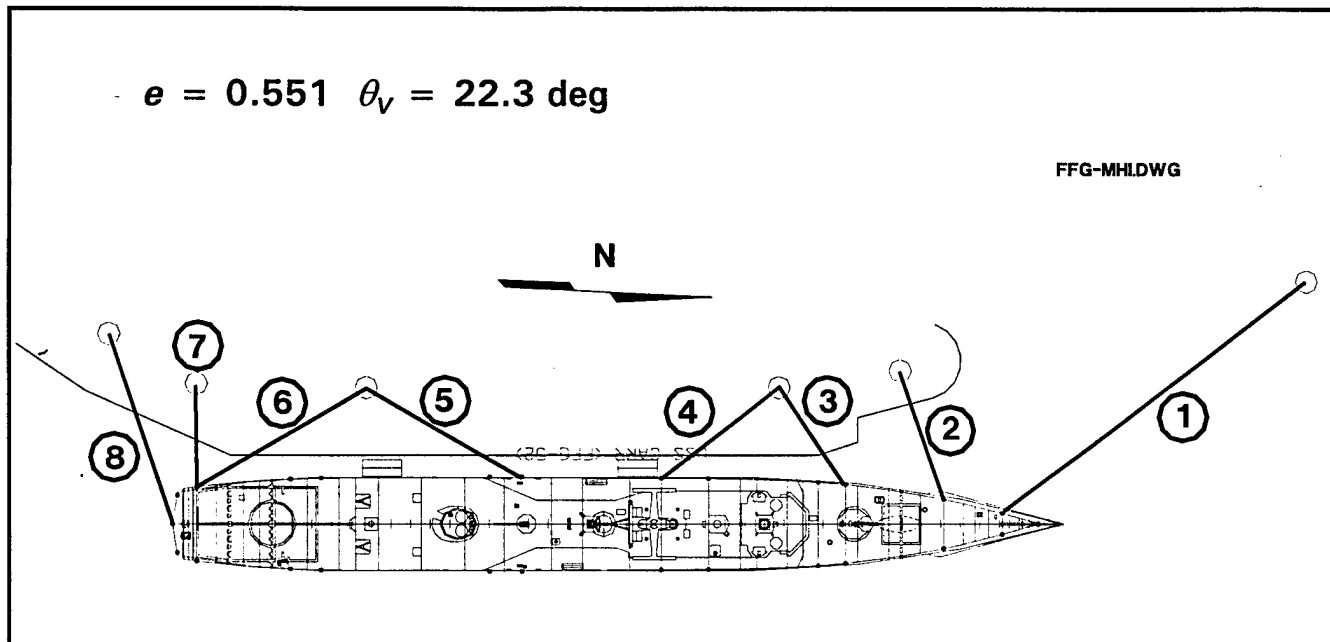

Figure A-5. FFG-47 Moored at MHI East Facility in 1997

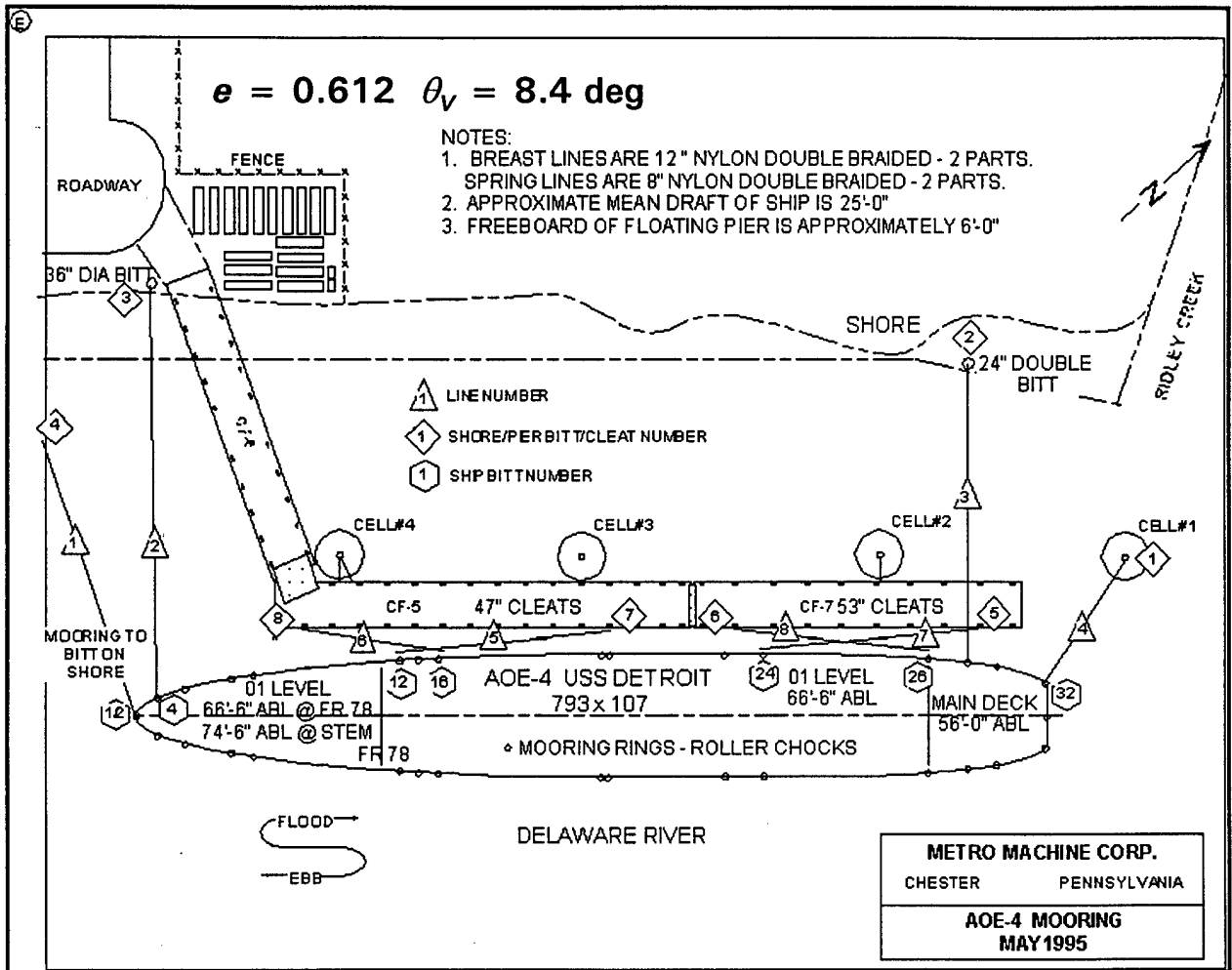

Figure A-6. AOE-4 at METRO Chester Facility at One-Third Stores in 1997

(Note Breasting Line Number 4 is Less Than Half the Length of Other Breasting Lines, so it Becomes Overloaded and Reduces Efficiency "LOW e")

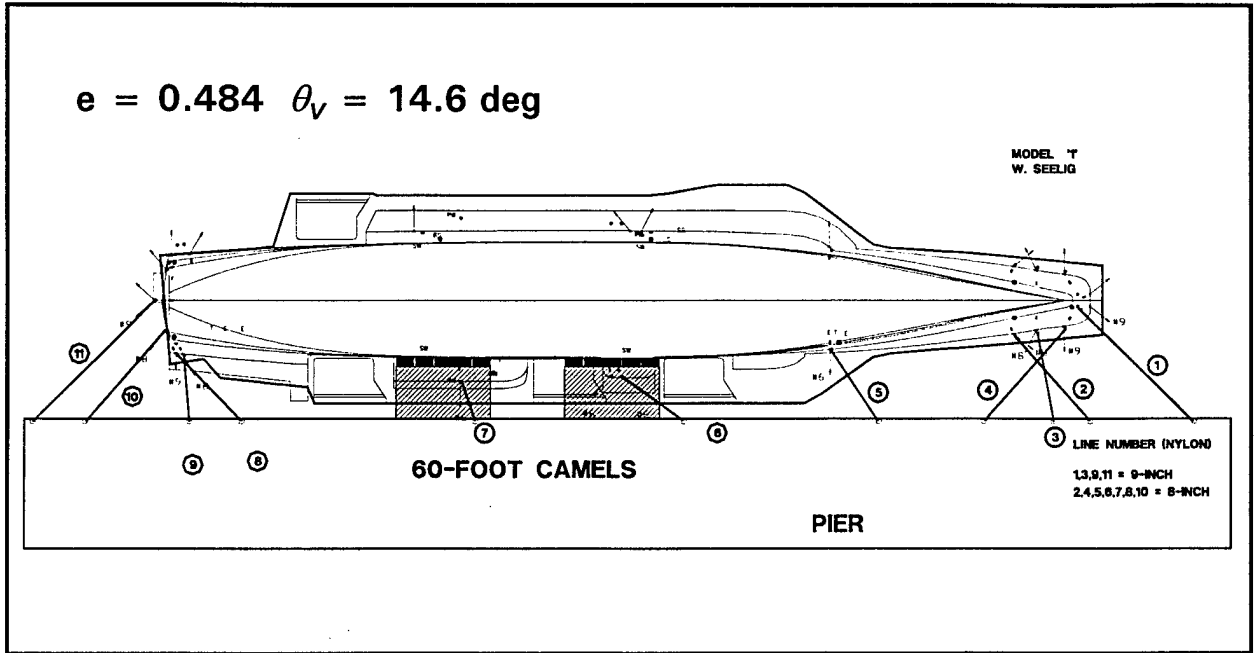

Figure A-7. 'Standard' Aircraft Carrier Mooring
Piers 11 and 12 Naval Station, Norfolk, Va ("LOW e")

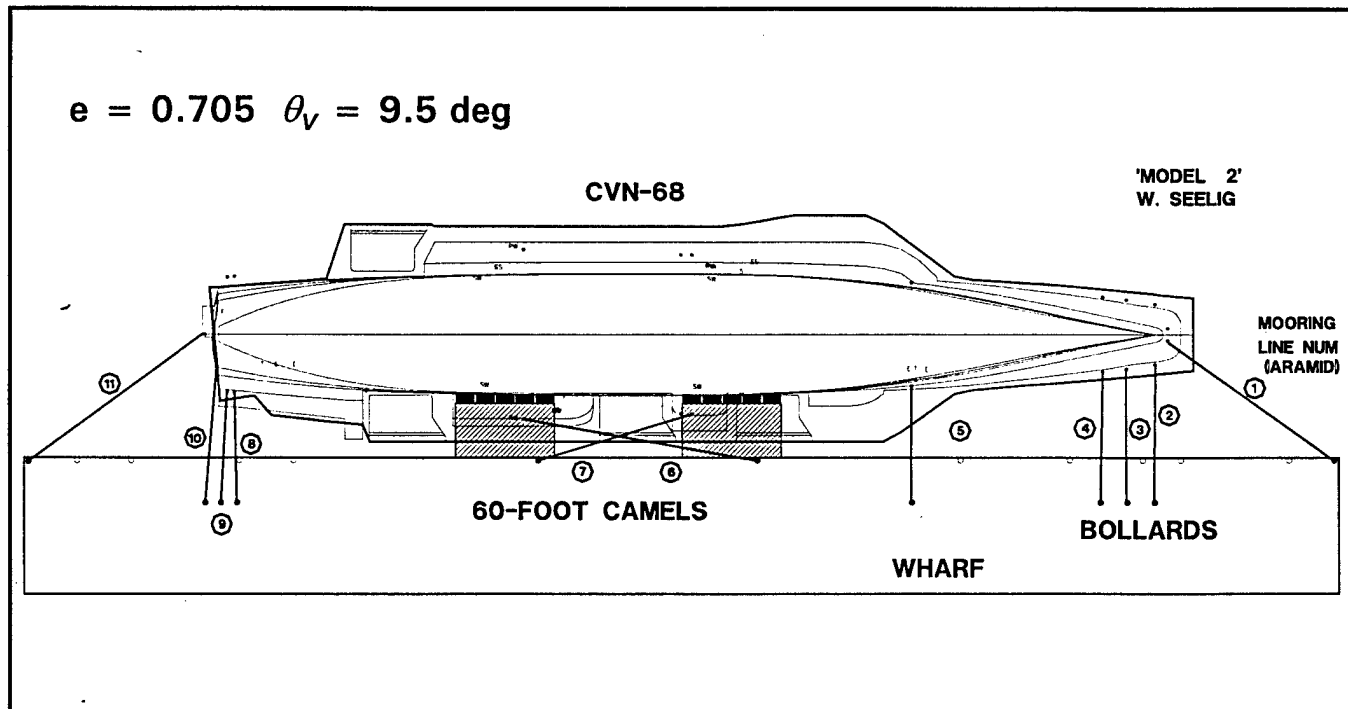

Figure A-8. Improved Wharf Aircraft Carrier Mooring Design Concept

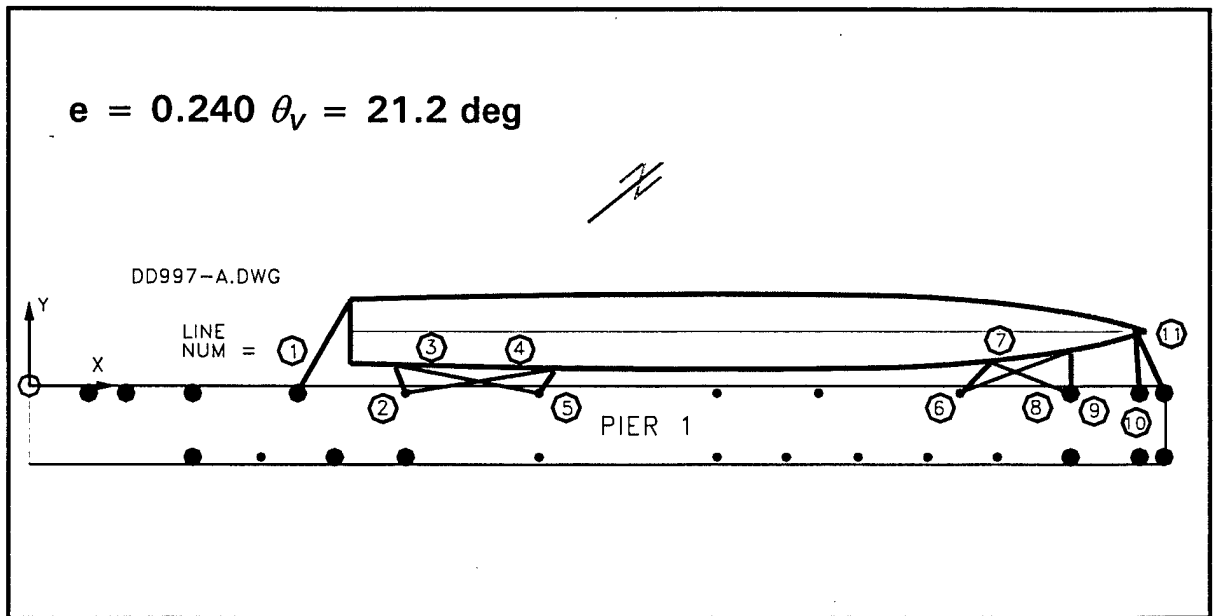
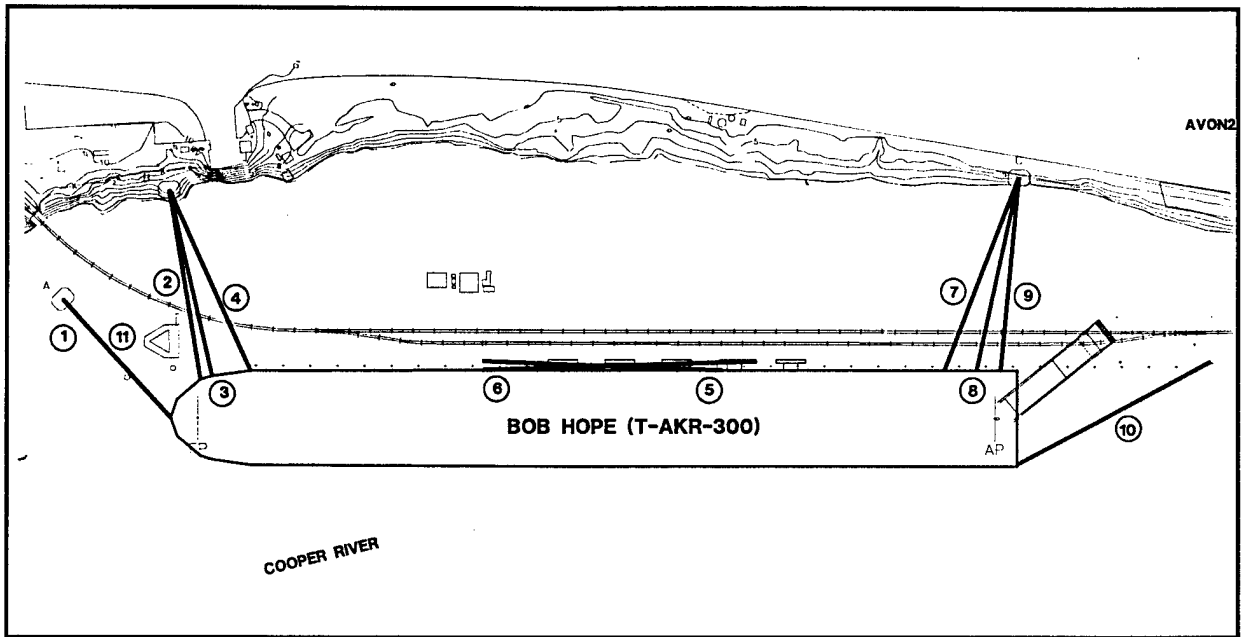

Figure A-9. DD-997 HAYLER at MOON Pier NO. 1 ("LOW e")



MOORING	e	θ_v (deg)
11 LINES	0.608	13.7
OMIT LINES 5,6,11	0.778	12.8

Figure A-10. BOB HOPE (T-AKR-300) AT WHARF ALPHA
CHARLESTON, SC (after S.Rice)

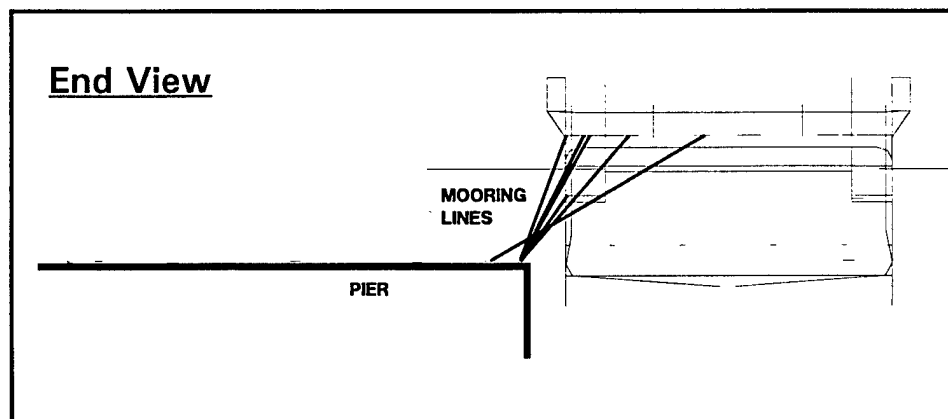
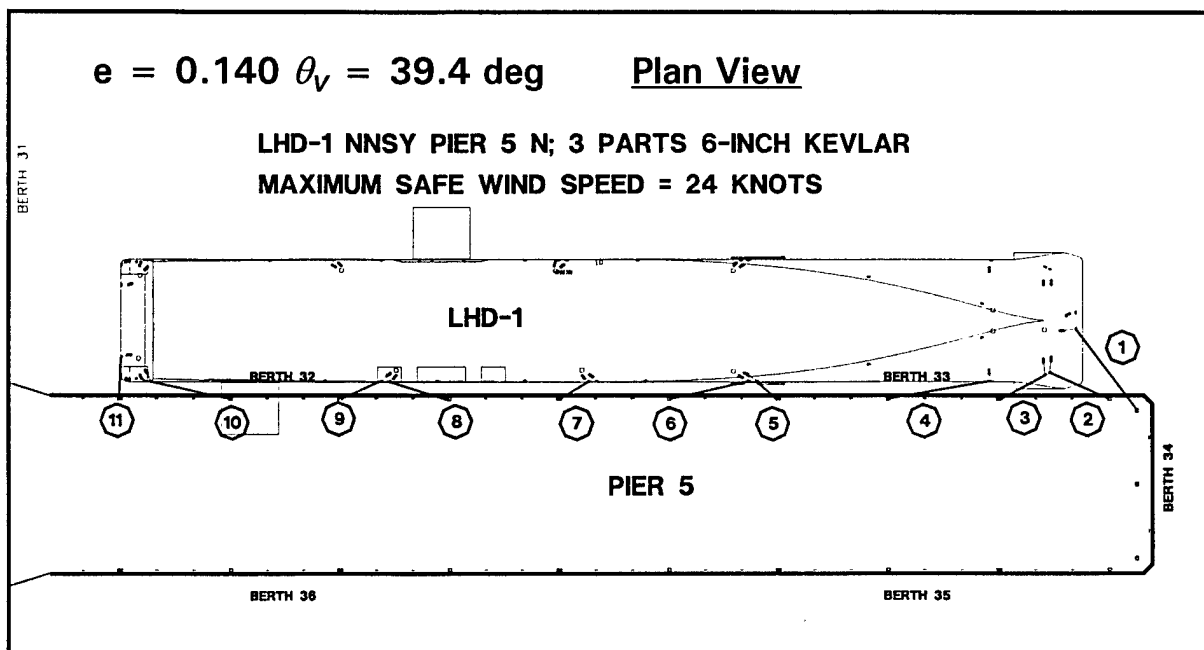

Figure A-11. LHD-1 MOORING AT NORFOLK NAVAL SHIPYARD
 (after Waller, 1998, personal communication "LOW e")

(mooring is low efficiency because of large vertical and horizontal angles; pier and ship fittings are not suited to one another for efficient mooring)

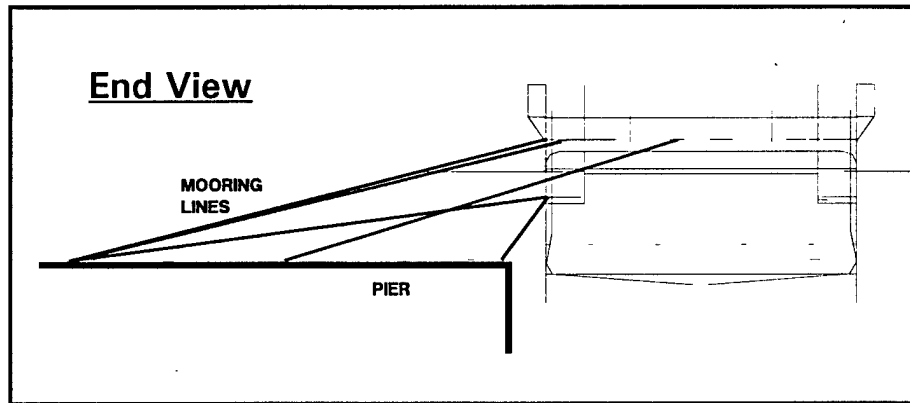
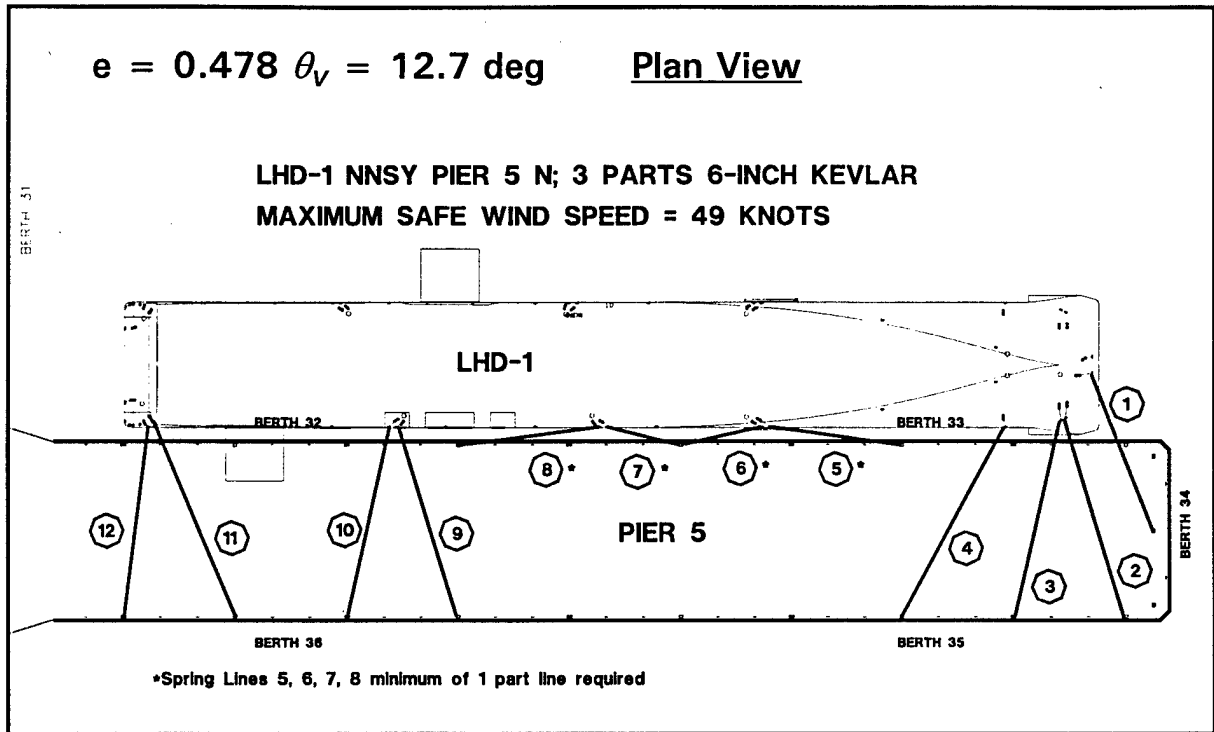

Figure A-12. IMPROVED LHD-1 MOORING AT NORFOLK NAVAL SHIPYARD
 LINES RUN ACROSS TO THE OTHER SIDE OF THE PIER
 (after Waller, 1998, personal communication)

(efficiency slightly low)