

19990504 013

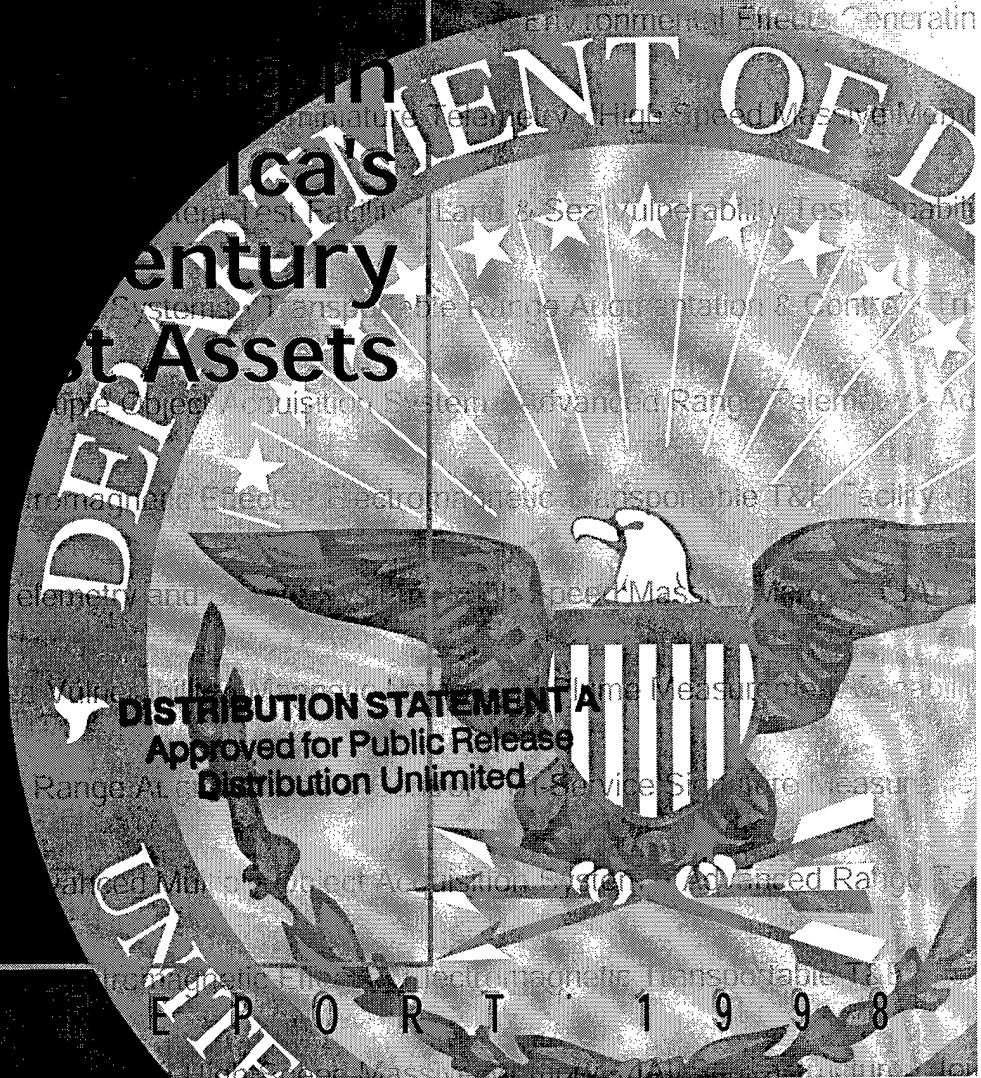

DISTRIBUTION STATEMENT A
Approved for Public Release
Distribution Unlimited

REPORT 1998

Table of Contents

Executive Summary	1
CTEIP Success Stories	5
Joint Improvement and Modernization Projects	9
Continuing Projects:	
Advanced Range Telemetry	11
Advanced Static Radar Cross Section Measurement System	13
Airborne Separation Video	15
DoD Software Alpha Testbed	17
Electromagnetic Environmental Effects Generating System	19
Foundation Initiative 2010	21
Hardened Subminiature Telemetry and Sensor System	23
High Speed Massive Memory/Electronic Film Capability	25
Joint Advanced Distributed Simulation Prototype Virtual Range	27
Joint Advanced Missile Instrumentation	29
Joint Installed Systems Test Facility Upgrades	31
Magnetic Levitation Upgrade	33
Multi-Service Target Control System	35
Plume Measurement Capability Facility	37
Target Systems Modeling and Simulation	39
Target Threat Validation	41
Translated GPS Range System	43
Transportable Range Augmentation and Control System	45
Tri-Service Signature Measurement and Database System	47
Weapons Modification and Simulation Capability	49
New Start Projects:	
Advanced Multiple Object Acquisition System	53
Big Crow EW Enhancement Program	54
Electromagnetic Compatibility Automated Test	55
Electromagnetic Transient Test and Evaluation Facility	56
Joint Modeling and Simulation System	57
Land and Sea Vulnerability Test Capability	58
Threat Systems Simulator Development	59
Test Technology Development and Demonstration	61
Resource Enhancement Project	71

Appendix A JIM Milestones Chart

Appendix B MRTFB Map

Appendix C JIM Contractors and Government Points of Contact

Executive Summary

The Central Test and Evaluation Program (CTEIP) continues to meet the challenges presented by declining investments in test assets and increasing test requirements. The Office of the Secretary of Defense (OSD) is shouldering an ever-growing portion of total investments in defense test and evaluation (T&E), and it does so principally through the CTEIP. This program, which remains the only vehicle within the Department of Defense (DoD) to provide a coordinated process for making joint investments in T&E, is executing the guiding principles of the Quadrennial Defense Review (QDR). The vision of the QDR centers on increased jointness, elimination of duplicative efforts, and maximizing use of scarce resources, all of which are clearly represented in the key objectives of the CTEIP. Specifically, through a corporate approach to investments in T&E infrastructure, CTEIP seeks to:

- Support joint projects that apply state-of-the-art technologies to correct deficiencies in DoD T&E capabilities and improve the efficiency of the test process;
 - Maximize efficient inter-Service use of test assets by improving interoperability and interconnectivity among test centers, ranges, and facilities;
 - Establish and maintain a T&E technology development program to investigate, develop, and produce prototypes of advanced technologies for application to T&E that reduce manpower requirements, operating expenses, and maintenance requirements;
 - Develop instrumentation and methodologies for evaluating and mitigating the environmental impacts of test activities;
- Achieve consistency, commonality, and interoperability across the Services in test instrumentation, targets, and threat simulators;
 - Develop, validate, and integrate modeling and simulation (M&S) with open-air testing to provide timely, accurate, and cost-effective results;
 - Exploit mobile test instrumentation capabilities as an alternative to fixed facilities where economically and technically feasible; and
 - Support U.S. economic competitiveness initiatives by promoting opportunities for nonmilitary application of DoD T&E investments.

Through the careful selection of projects and subprojects, CTEIP ensures that scarce assets are applied in areas that hold the potential of producing the best returns on investments and reducing unwarranted duplication of test assets and capabilities.

CTEIP Selection Process

CTEIP projects are selected via a process that ensures the active participation of all concerned parties and fosters a robust competition for limited assets. Through a Needs and Solutions process, joint CTEIP projects are selected from candidates submitted from the Services and Defense Agencies or are developed from OSD initiatives. Candidate projects from the Services are first reviewed by the Test and Evaluation Reliance and Investment Board (TERIB) and the Defense T&E Executive Agent structure to obtain consolidated Service recommendations prior to further consideration. The TERIB also reviews candidate submissions from the Defense Agencies to ensure that



unwarranted duplication is eliminated. This process has fostered improved coordination and cooperation, which benefits the entire test community. The Test and Evaluation Resources Committee (TERC), under the auspices of OSD, then reviews the submissions and selects recommended projects for presentation and approval by the Defense Test and Training Steering Group (DTTSG).

CTEIP Project Categories

CTEIP consists of three categories of projects: Joint Improvement and Modernization (JIM) projects, Test Technology Development and Demonstration (TTD&D) subprojects, and Resource Enhancement Project (REP) subprojects.

JIM Project Accomplishments

JIM projects address critically needed T&E investments in the major functional areas and comprise the majority of CTEIP. Generally the largest of CTEIP projects in terms of funding and scope, JIM projects must meet stringent criteria such as multi-Service or joint application and acceptable risk and cost. In FY97, two JIM projects reached full operational capability, the Common Airborne Instrumentation System and the Smart Munitions Test Suite. The benefits that are already accruing from the new capabilities these projects have provided are outlined in detail in a separate section of this report. Ongoing projects in FY98 continue to produce results that are immediately translated into cost savings and improved test capabilities. A number of completed subprojects of the Weapons Modification and Simulation Capability project have produced significant savings in the use of Applied Computational Fluid Dynamics and Computerized Physical Fit for external and internal aircraft stores test certification.

In some cases, JIM projects carry forward new and innovative technologies that were first demonstrated as TTD&D subprojects, a category of CTEIP that is described below. This is true of the Hardened Subminiature Telemetry and Sensor System, which will continue development of a miniaturized instrumentation that is capable of surviving very high-G conditions to provide telemetry data during the test of submunitions, projectiles, missiles, and smart munitions.

One objective of the CTEIP program is to foster increased use of M&S to maximize use of test and training assets, both real and virtual. In FY98, four JIM projects, the aims of which were complementary and directly contributing to M&S initiatives, were combined under one overarching project. The efforts of these projects, Test and Training Enabling Architecture; Virtual Test and Training Range; Common Display, Analysis, and Processing System; and Joint Regional Range Complex; are now being conducted within the Foundation Initiative 2010. The aim of this new project is to promote the seamless integration of live, virtual, and constructive resources to create the realistic test and training environments that will simulate modern battlespaces across multiple ranges.

TTD&D Accomplishments

TTD&D projects contribute to new, innovative test techniques and capabilities and develop test technologies for wider application in order to reduce risk in testing future weapons systems. FY97 saw the completion of several TTD&D subprojects that have had direct applicability to current test requirements. Among these was the Airborne Wake Vortex Measurements subproject, which developed an airborne laser velocimeter that is capable of measuring the strength of aircraft wake vortices from a distance of 50 feet. The ability to functionally represent threat laser systems to systems under test and in training scenarios in an eye-safe manner was also developed by the Eye-Safe Threat Laser subproject.





In FY98, TTD&D subprojects will continue to provide an arena for the demonstration of high technology test techniques and capabilities.

REP Accomplishments

REP supports subprojects that are tailored to resolve near-term Operational Test (OT) capability shortfalls through immediate funding and development. In FY97, numerous subprojects of the REP reached operational status, among them was the Corps Battle Simulation Army Tactical Command and Control System, which completed the development of hardware and software to enable a unit under test to be enveloped within a simulated command structure, thus providing increased test realism. A new capability was developed by the REP in the Flying Infrared-Signature Test Aircraft, which supports the Air Force with a new capability to make well-calibrated measurements of infrared (IR) signatures of aircraft, missiles, rockets, and their respective backgrounds. This subproject also provides a database for validation of visible and IR simulation programs. The Range Signal Density Enhancement System was also completed in FY97, providing a more realistic battlefield radio frequency environment in which both hostile and friendly emitters are represented with modern signal types.

Operational test will continue to be facilitated in FY98 by subprojects such as the Aerial Target Launch Ship. This subproject will provide a greatly enhanced ability to present targets to test systems in a realistic environment by producing a self-propelled, maneuverable surface launch capability for aerial targets at sea. Other subprojects, like Vulnerability Assessment, are furthering the development of M&S applications to testing in electronic warfare environments. In this case, detailed models are being developed to assess the vulnerability of foreign systems to U.S. jammers.

Program Review

CTEIP projects undergo rigorous and periodic review, both for continued technical merit and for affordability. As a result of such scrutiny, two major JIM projects were substantially redirected by OSD during FY98. One, the Next Generation Target Control System, is undergoing a complete revision and redefinition of requirements, based upon project cost growth. The Magnetic Levitation Upgrade is the other, which, as of this writing, is awaiting the results of a review of manufacturing technology to determine whether using magnetic levitation technology is feasible and affordable.

CTEIP Contributions to the Integration of Testing and Training

To help maximize scarce testing and training investment resources, increased emphasis has been placed on improving the coordination between the training and testing communities. While the conduct of training operations on test ranges and of testing events on training ranges is becoming more common at many ranges today, the processes and procedures in place are presently not conducive to integration. In FY98, CTEIP is continuing to seek opportunities to promote commonality and interoperability between test and training instrumentation and range infrastructure. The DTTSG was formed to help facilitate this integration. As a key member of the CTEIP selection process, the DTTSG evaluates the potential of CTEIP candidate projects to capitalize on joint planning and investments in testing and training facilities and resources.



CTEIP Success Stories

Smart Munitions Test Suite (SMTS)

SMTS has successfully transitioned from a developmental project to operational status at the White Sands Missile Range. Scheduled to support an upcoming Brilliant Anti-Armor Submunition/Army Tactical Missile System (BAT/ATACM) test, the system is now fully operational and exited the CTEIP in FY97. SMTS offers a test capability unattainable through previous instrumentation systems. Providing a multi-sensor suite of integrated instrumentation, SMTS now permits the capture of comprehensive test data on multiple smart and brilliant submunitions from their dispensing from carrier vehicles to their points of target impact. The system supports both operational and developmental testing by providing extensive event and time-space-position-information (TSPI) without affecting the performance of the system under test—and SMTS can provide this information on over 40 autonomous, maneuvering objects in flight, fusing real-time sensor data from a variety of sources. This information, stemming from phased-array radar, optics, Global Positioning System, and telemetry is then displayed for mission rehearsal, conduct, and post-mission analysis.

Common Airborne Instrumentation System (CAIS)

The development of CAIS has provided an interoperable airborne instrumentation system that will obviate the need for individual Services to independently develop instrumentation for each new major weapon system procurement. The system promotes interoperability across test activities by providing an architecturally common instrumentation system and standardized airborne instrumentation preflight and mainte-

nance equipment. Funded by CTEIP through 1997, CAIS was developed in a cooperative effort by the three Services and managed through a tri-Service Memorandum of Agreement. CAIS comprises a standard complement of hardware and software that will be used to instrument present and future aircraft, as well as other vehicles. The system is designed to meet core instrumentation requirements throughout the 1990s. With output rates from 2 kilobits per second to 50 megabits per second, CAIS is fully programmable and has a maximum input capacity of 8000 channels. The system is modular, which permits expansion or contraction of capabilities to meet a particular project's data acquisition requirements. Having successfully flown on the F/A-18 E/F, F-22, and B1-B, CAIS is planned for use in testing the Joint Strike Fighter.

Weapons Modification and Simulation Capability (WMASC)

In FY95, a subproject of WMASC, Rotary Wing Stores Separation (RWSI), reached initial operating capability. A computer simulation was developed under this subproject that uses wind tunnel data, techniques from computational fluid dynamics, and advanced video technology to provide data and ballistic accuracy for testing of stores separation from rotary wing aircraft. As part of its testing of AH-64 rocket firing envelopes, the Army used the RWSI to realize significant savings by avoiding traditional buildup flight testing. Early qualifications for the AH-64 had omitted rearward and sideward firing, and operational concerns resulted from this omission. Estimates to provide the data that would permit the expansion of the rocket firing envelope through buildup from hover using multiple data points and film



data inspection ran as high as \$8.5M, a cost that was deemed excessive. Accordingly, the Army used RWSI technology to “piggy-back” on previous tests and expanded the firing envelope to operational needs at an estimated cost of only \$219K. In view of the costs for traditional testing, had the RWSI technology not been available, it is doubtful that the operational capability would have been obtained.

In the summer of 1997, certification of the AQM-37 drone on the F-16 became a critical problem. Principally lacking was adequate information to assess aerodynamic loads on the modified pylon, as well as the drone itself. With no wind tunnel data available and not enough lead time to obtain it, Applied Computational Fluid Dynamics techniques developed by the WMASC project were used to provide high-fidelity modeling and simulation of the aerodynamic loads on the stores configuration at a number of critical test points. This effort, conducted in the space of 4 weeks, is estimated to have saved \$800K from avoided costs for wind tunnel testing.

Aerial Cable Test Capability (ACTC)

Fully operational since 1996, ACTC addresses a shortfall in presenting repeatable aerial target presentations and air delivery of components and subsystems. Prior to the development of the ACTC, limitations on testing of many weapons systems were encountered due to the high cost, difficulty of repetition, and slowness of turnaround encountered in using conventional test methods such as remotely piloted vehicles and manned aircraft. ACTC, located at the White Sands Missile Range, consists of a 3-mile-long, 2.5-inch-diameter cable spanning two mountain peaks. The cable serves as a path for a captive vehicle that moves at controlled speed at a predetermined altitude—either propelled by gravity or rocket assisted. The system is capable

of presenting a target payload of 20,000 lb. at speeds up to 250 knots. During actual operations, considerable cost savings have been realized through the system’s vehicle size, which permits numerous testers to share space and time on each live-fire test. By the end of 1996, ACTC had paid for itself in cost avoidance and has consistently provided enhanced data collection and safety.

The Resource Enhancement Project (REP)

REP funds subprojects to resolve near term operational test resource shortfalls whose non-availability could introduce high risk in the development and evaluation of new weapon systems and system upgrades. The following are examples of REP accomplishments:

Corps Battle Simulation Army Tactical Command And Control System (CBS-ATCCS). This subproject has completed the development of hardware and software interfaces between the CBS model and the real-world ATCCS devices. It enables the tester to envelop the unit under test with a simulated command structure thus providing increased threat realism. CBS-ATCCS supported the operational testing of ATCCS I, II, III, IV, and VI, Maneuver Control System, Combat Service Support Control System, and the Advanced Field Artillery Tactical Data System (AFATDS) interoperability operational test.

E-9A Airborne Telemetry Platform Upgrade (E-9A UG) provides an over-the-horizon, ultra high frequency, command initiate and destruct relay system and increased telemetry receive and record data rates up to 10 Mbits/sec. In FY97, the E-9A flew approximately 425 hours in support of various programs conducting initial operational test and evaluation (IOT&E), follow-on test and evaluation (FOT&E), and weapons competitions. E-9A supported the F-15 / F-16 Operational Flight Program (OFF), the Advanced Medium Range Air-





to-Air Missile (AMRAAM), Advanced Short Range Air-to-Air Missile (ASRAAM), AIM-7, AIM-9, and Navy TOMAHAWK program.

Global Command & Control System (GCCS) Operational Test Bed was built to emulate a standard Commander in Chief (CINC) hardware and software configuration to include workstations, servers, routers, and a 512Kb bandwidth Secret Internet Protocol Router Network (SIPRNet) connectivity line. This connectivity provided access to the 37 OT&E initial operational capability (IOC) test sites and more than 400 other CINC and Service sites around the globe. Some of the most significant testing supported by this subproject included database synchronization testing for all 16 primary World Wide Military Command and Control System (WWMCCS)/GCCS database sites, OT&E for software version 2.0 in support of Joint Staff WWMCCS shutdown and GCCS IOC decisions, OT&E for Top Secret Support System for Central Command (CENTCOM), OT&E for remote site configurations and applications for European Command (EUCOM), Best of Breed testing for Joint Staff for various GCCS applica-

tions, and the combined development testing/operational testing (DT/OT) multi-node and security testing in direct support of the GCCS Program Management Office.

Range Signal Density Enhancement System (RSDE) provides testers with a more realistic battlefield radio frequency (RF) environment, comprising hostile and friendly emitters with modern signal types. Located at the Electronic Combat Range (ECR), Naval Air Warfare Center Weapons Division, China Lake, California, it is capable of generating 128 signals simultaneously and pulse densities in excess of 5 million pulses per second. RSDE supported the testing of Navy's AN/ALE-50 (DT and OT) and the AN/ALR-67(V)3 (DT), an EW suite on the Air Force's F-16, and for a Radar Warning Receiver (RWR) installed on F-5 FMS program. RSDE is available to support additional planned testing on AN/ALR-67(V)3 & 4 Advanced Special Receiver (ASR), F-14D, V-22, and F/A-18E/F.



Joint Improvement and Modernization Projects

Continuing Projects

- ◆ Advanced Range Telemetry
- ◆ Advanced Static Radar Cross Section Measurement System
- ◆ Airborne Separation Video
- ◆ DoD Software Alpha Testbed
- ◆ Electromagnetic Environmental Effects Generating System
- ◆ Foundations Initiative 2010
- ◆ Hardened Subminiature Telemetry and Sensor System
- ◆ High Speed Massive Memory/Electronic Film Capability
- ◆ Joint Advanced Distributed Simulation Prototype Virtual Range
- ◆ Joint Advanced Missile Instrumentation
- ◆ Joint Installed System Test Facility Upgrades
- ◆ Magnetic Levitation Upgrade
- ◆ Multi-Service Target Control System
- ◆ Plume Measurement Capability Facility
- ◆ Target Systems Modeling and Simulation
- ◆ Target Threat Validation
- ◆ Translated GPS Range System
- ◆ Transportable Range Augmentation and Control System
- ◆ Tri-Service Signature Measurement and Database System
- ◆ Weapons Modification and Simulation Capability





Joint Improvement and Modernization (JIM) projects are those CTEIP projects which consist of investments to improve the test capabilities base. The JIM projects represent critically needed test and evaluation investments in the major functional areas of test mission command, control, communications and instrumentation; electronic warfare systems; threat and computational simulation test and evaluation; space system test and evaluation; weapons effects test capabilities; targets; and physical and environmental test capabilities. The investments are made in the development of advanced technologies needed to meet the testing of increasingly complex and sophisticated systems including automated data collection, processing, display, and archiving; smart munitions testing; simulation and end-game measurement; testing of advanced materials application; test design; and advanced sensors and space systems.



Advanced Range Telemetry (ARTM)

Note: This project is also receiving TTD&D funding.

The objective of ARTM is to improve the efficiency, reliability, and utility of DoD flight-test telemetry (TM) links. This will be accomplished by investigating and developing TM technologies such as higher order modulation techniques, data compression, error coding and correction of data-improved antenna designs, improved frequency scheduling tools, and the development of on-board data processing systems.

Requirement

Real-time aircraft and missile test TM data requirements have grown exponentially. This is primarily due to increased technical complexity of weapons systems and military air vehicles. As the complexity grows, more real-time flight-test data is required to maintain today's level of test safety and efficiency. In addition, the electromagnetic spectrum allocated to aeronautical flight test has decreased over the past few years and continues to be threatened by the

commercial telecommunications industry. The DoD test and training community must satisfy customer needs for higher throughput and improved reliability of real-time TM data – in a limited spectrum environment – in order to minimize cost and schedule impacts to aeronautical test operations.

Description

The ARTM program will improve the efficiency, reliability, utility, and availability of aeronautical TM spectrum. This will be accomplished by developing a series of system upgrades as described below that can be implemented at all DoD Major Range and Test Facility Base locations. See Figure 1.

- **Bandwidth Efficient Modulation.** Higher order modulation techniques that increase data throughput have been developed and fielded recently in commercial telecommunication systems. ARTM will identify, test, and adapt these techniques applicable to aeronautical TM.
- **Data Compression.** In order to decrease telemetry link bandwidth required for test missions, loss-less data compression can be used. ARTM will explore and test existing data compression techniques that can be adapted to aeronautical TM. In addition, new adaptive methods will be investigated in the hope of mitigating the classic deficiencies inherent in lossless compression.
- **Error Correction.** Many flight telemetry applications experience periods of unacceptably high bit error rates that impact test schedules. Data encryption, data compression, and high spectral efficiency

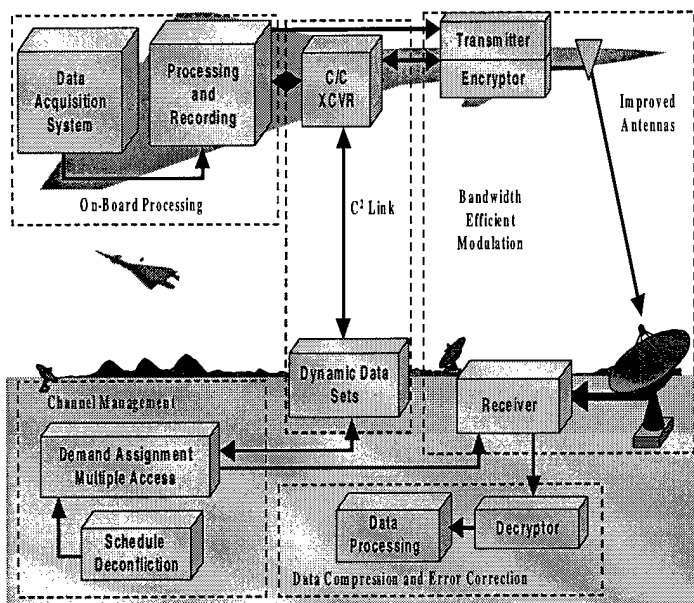

Figure 1. ARTM System Level Diagram

modulation methods all exacerbate the problem. Appropriate coding and error correction techniques will be developed as needed to ensure data quality standards are maintained or improved.

- **Channel Management.** The aeronautical TM spectrum is a resource as critical to flight test as other limited resources (people, funding, airspace, etc.) and must be managed efficiently. ARTM will provide ranges with the scheduling/deconfliction tools and flexible equipment required to maximize availability and utility of TM spectrum.
- **On-Board Processing.** A vast majority of real-time TM processing is performed at ground-based locations. ARTM will investigate the feasibility of applying onboard processing.
- **Command and Control (C²) Link.** The capability to command and control onboard TM equipment (acquisition systems, transmitters, recorders, etc.) could provide operational benefits. ARTM will investigate the feasibility of implementing and utilizing a C² link.

Benefits

The major benefit of ARTM is the expanded capability it will provide for DoD test ranges. Another key benefit of ARTM will be commonality. Through cooperation and standardization, MRTFB ranges currently have established common, interoperable telemetry systems. These provide a solid baseline that can only be maintained through a tri-Service development effort such as ARTM. Cost savings will be realized through joint development, production, and sustainment.

Progress & Completion

In FY98, ARTM is focusing on research and risk reduction. A TTD&D effort and academia research grants will solidify program plans for FY99

and beyond. Some of the planned FY98 efforts include the following areas: TM channel characterization, advanced modulation demonstration, data transport protocols, space communication protocol standard, research efforts, Small Business Innovative Research efforts, and program planning.

Ground and flight tests will be performed to collect data required to characterize aeronautical TM channels. Modulation techniques that can potentially double current throughput have been identified and tested in laboratory environments. These techniques have been implemented in prototype hardware and will be demonstrated in a realistic range environment. A preliminary "packet telemetry" study is scheduled for completion in 1998. As source code is made available and porting to the Microsoft "Windows NT" operating is accomplished in a related effort, the ARTM staff hopes to begin testing the Space Communications Protocol Standards for use in C² uplinks.

Four university grants were awarded in December 1997 to research potential ARTM solutions. Two additional grants are planned for FY98. Additionally, government research efforts into error correction, antenna design, data compression, and data management are planned. A Test Capability Benefit Analysis will be completed. The Program Management Plan, including schedule and budget, will be updated based on FY98 research and risk reduction.

Schedule

Milestones	FY98	FY99	FY00	FY01	FY02
Program Definition	x x				
Technology Research	x x x x				
Prototype Testing		x x x x x x			
Initial Production			x x x x x x x x		
Efficient Modulation IOC-FOC				x x x x x x	
Data Compression IOC-FOC				x x x x	
Error Correction IOC-FOC				x x x	
Chan Management IOC-FOC				x x x x	
Advanced Antenna IOC-FOC					x x x x x
C2 Link IOC-FOC					x x x x x
Range Integration				x x x x x x x x x x x x	

Advanced Static Radar Cross Section Measurement System (ASRCS)

The ASRCS measurement system is designed to upgrade the outdoor radar cross section (RCS) measurement facilities at Holloman AFB, New Mexico, for the next generation of stealth weapon systems. The Radar Target Scatter (RATSCAT) facility is a division of the 46 Test Group at Holloman AFB, New Mexico, and is physically located at two sites (RATSCAT Mainsite, and RATSCAT Advanced Measurement System (RAMS)) on White Sands Missile Range, New Mexico. It has been in operation since 1964.

Requirement

A multi-Service requirement exists for highly accurate RCS measurements of conventional and low observable (stealth) weapon systems. This measurement data is required for all phases of weapon system acquisition programs and tactical mission planning. Ultimately, the data is used to determine the survivability and vulnerability of weapon systems. Advanced weapon systems require measurement accuracies that are near or exceed the capabilities of present measurement systems. This project focuses on a number of critical areas. Low frequency improvements are being addressed with the RAMS VHF/UHF Measurement System (RVUMS). Data Acquisition and Processing System (DAPS) improvements will

provide one common system architecture, one set of common hardware, and one set of software for all radar systems at RATSCAT. This architecture can be used by any radar measurement facility. Bistatic radar diagnostic capabilities for improved counter-stealth diagnostic measurements, near-field measurement capabilities for improved missile radar seeker evaluation, and mobile imaging radar for high-resolution diagnostics of missiles and aircraft are embedded in this requirement. Methods of reducing radar signatures of the supports that hold and position the targets during testing are being addressed in the PYLON Improvement project. The high frequency radar at the premier DoD static RCS range at RAMS must be upgraded to improve sensitivity, dynamic range, and data throughput.

Description

The existing pylon at RAMS was designed for high frequency measurements. An upgraded pylon is required to test Low Observable test articles at VHF, UHF, and microwave frequencies (see Figure 2). Additionally, advanced target suspension and support systems will be developed to reduce background levels and target/support interactions to near noise levels. Advanced signal processing techniques will also be available and are a key element of the Pylon upgrade subproject.

The DAPS upgrades both mainsite and RAMS with modern computers and software that is common between the facilities and includes off-the-shelf modules that are common with other RCS ranges. This allows operators who are trained at RAMS or Mainsite to conduct tests at either facility with a minimal amount of additional training. The new Operation and Maintenance

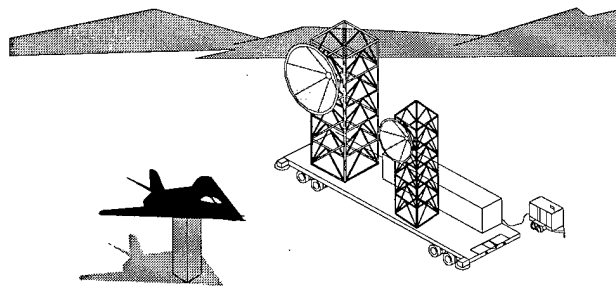

Figure 2. Low Frequency Measurement System



(O&M) contract has a greatly reduced staff and cross-utilizes the people between sites.

The Bistatic Coherent Measurement System (BICOMS) subproject provides both bistatic and monostatic testing capability at Mainsite. The current radar at Mainsite (Scientific Atlanta 2090) is over 10 years old. It requires over 2 hours to accomplish a wide band measurement, while modern radar can make this same measurement in about 12 minutes. BICOMS will allow coherent bistatic measurements using two radars. A fixed radar unit (FRU) will be an upgrade to the mainsite radar, and a second mobile radar unit (MRU) will be provided. The MRU will allow for near field mono-static measurements as well as near or far field bistatic measurements.

The RAMS radar (SPC Mark III) is the original radar built for RAMS in the early 1980's. This radar has limited dynamic range, performs co-polarization measurements only (except at X-band), and is difficult to maintain because of the difficulty in finding parts. A new radar will be much less expensive to maintain, can meet the needs of full scattering matrix testing, and offers many features which customers have come to expect. The RAMS radar upgrade works in tandem with the PYLON improvements to greatly enhance the ability to measure low observable targets.

Benefits

As an independent Government test facility, RATSCAT collects highly accurate radar signature measurement data of flyable aircraft and highly detailed scale models. The data are used for all phases of weapon system acquisition programs to validate modeling and prediction codes for weapon system design, product improvement, specification validation, and ultimately, tactical mission planning. The data are also used to augment and validate data gathered by ground-to-air and air-to-air RCS measurement systems. Problems can be diagnosed and corrected

more quickly and at a lower cost at RATSCAT than during the later flight-test program.

Schedule

Milestones	FY97	FY98	FY99	FY00
BICOMS				
MRU IOC		x		
FRU IOC			x	
FOC			x	
RAMS Radar Upgrade				
FOC			x	
DAPS				
FOC		x		
Pylon				
FOC				x

Progress & Completion

FY97 was a highly successful year for the ACRCs. The BICOMS has gone from design and development to systems integration and testing. All major subsystems are built or nearing completion. The original schedule was maintained even though the contract was delayed by two months. BICOMS remains on schedule and within cost for FOC in September 1998. The Pylon subproject also went on contract during March 1997, and the first phase of the pylon upgrade was concluded in August 1997. This subproject remains on schedule and within cost, with decision requirements for Phase IV in December 1997. If the option for Phase IV is not exercised, the pylon upgrade will complete in the first quarter of FY00. DAPS was fully operational in December 1997. RVUMS was completed in the fourth quarter of FY94, and is currently supporting nearly one-third of all testing at RAMS. RAMS radar was projected for development in FY97; however, funding was not available until FY98. A 9-month contract will be used to purchase an off-the-shelf (as much as possible), state-of-the-art radar system to replace the current Mark III at RAMS. FOC is scheduled for the first quarter of FY99.

Airborne Separation Video (ASV)

The ASV project, represented in Figure 3, will develop a direct-to-digital imaging system that allows for real-time and near real-time viewing of an event, data acquisition, and processing of digital data. This capability will provide processing improvement, real-time aircrew interface, and improved test schedules.

Requirement

The airborne community requires specific tools and capabilities to evaluate aircraft/store separation characteristics to support certification recommendations. One tool used is a flight-worthy, high-speed film camera that is carried externally on aircraft to document the separation characteristics of a store released from the aircraft. Once data is collected, the compatibility engineer conducts qualitative analysis by reviewing the film to evaluate store separation characteristics, such as store trajectory, store-to-aircraft collisions, store-to-store collisions, arming wire motion, nose fuse and fin operation, and failure modes. If a more precise analysis of the store's trajectory is necessary, a quantitative analysis is conducted using computer hardware and software, which steps through the data frame by frame to calculate the six degrees of freedom (x, y, z, roll, pitch, and yaw) of the store with respect to the aircraft. The data provided by film works well for analysis; however, there are a number of drawbacks in using film. There is no way of previewing the camera's settings and image quality prior to the store separation, which could cause loss of data. The film must be developed before viewing the data, which delays the process. The film is expensive and the film development chemical disposal is an environmental concern. Lastly, the digitization of the film for data

reduction is time consuming and expensive. Use of a digital imaging camera system in lieu of film cameras will obviate all of these disadvantages and will offer the potential to improve significantly the certification process. It will also allow for more efficient test schedules and reduce manpower needs. The same disadvantages that stem from the use of film also apply to the ground-based user, except that higher frame rates and better resolution are often required.

Description

The first phase of the ASV project is a form, fit, and function replacement (as nearly as practical) of the flight-worthy, high-speed film cameras carried externally and internally (within specially modified fairings and weapon bays) on aircraft. The cameras to be used include a Near Term Test Capability (NTTC-P) camera, a NTTC-V camera, a NTTC Remote Sensor (NTTC-RS) camera, a Long Term Test Capability (LTTC) camera, and an Ultra High Speed Ultra High Resolution camera. The ASV will record in-flight separation of bombs, rockets, flares, fuel tanks, auxiliary suspension equipment, and captive carriage events information during daylight hours over land and sea. The ASV will use a Government-furnished telemetry system that allows the aircraft-store compatibility engineer to preview the lighting

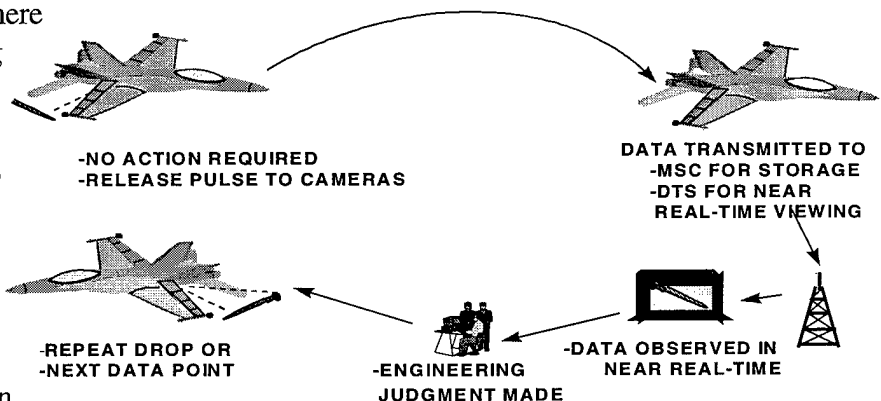

Figure 3. Airborne Separation Video

conditions prior to store release and to download separation data while the aircraft is airborne, providing real-time results to the test engineer for qualitative analysis. The direct-to-digital data format will speed the post-flight qualitative and quantitative data analysis and avoid film's associated processing and disposal costs.

The ground-based portion is the follow-on phase of the ASV project, and its mission is to provide a digital imaging system which will replace the higher frame rate 16mm (20,000 pps), 35mm, and 70mm film cameras. These cameras record events such as rocket launches, kinetic contacts, and projectile trajectories, and their data is used to provide time-space-position information.

Benefits

Bomb drop tests from both a static bomb rack under controlled lighting conditions and a moving aircraft under ambient lighting conditions have been completed using both film and the ASV system with a NTTC camera. The tests demonstrated that the NTTC camera could be used to collect store release data to support accurate qualitative and quantitative data analysis. This technology could also be used in a similar manner for ground-based applications such as recording ordnance impacts, missile launches, and tracking test objects.

If ASV is used as a replacement for film, it will provide the following cost savings/avoidances: reduce manpower by replacing film laboratories and the associated staffing; decrease the effort required for installation of cameras on the aircraft prior to flight, and reduce the effort required in post-flight data analysis; allow for viewing of the tests before and during a mission, thus reducing risk and increasing the likelihood of a successful test by allowing real-time user interface to correct any errors prior to mission; reduce mission test schedules by permitting multiple test points per event, multiple events per mission, and allowing analysis of flight data before

the next mission; eliminate environmental concerns with the development and disposal of film; ease the storage problems associated with film (developed and undeveloped); eliminate the cost of purchase and development of film; and increase safety of weapons' separation and live-fire testing while providing immediate feedback.

Schedule

Milestones	FY98	FY99	FY00	FY01	FY02
NTTC-P/CCU/CRU/GIU					
Low Rate Production	X X X				
Full Production		X X X X X X X X X X X X X X X X			
NTTC-V & COLOR					
Low Rate Production	X X X				
Full Production		X X X X X X X X X X X X X X X X			
NTTC-RS					
Low Rate Production		X X X			
Full Production			X X X X X X X X X X X X X X X X		
MSC					
Low Rate Production		X X X			
Full Production			X X X X X X X X X X X X X X X X		
LTTC					
Low Rate Production			X X X X		
Full Production				X X X X X X X X X X X X X X	
Ultra High Speed & Res.					
Low Rate Production				X X X X	
Full Production					X X X X X X X X

Progress & Completion

The ASV first phase has been delivered to the Government and testing has been performed on the NTTC-P system (Cockpit Control Unit (CCU), Controller Recorder Unit (CRU), Ground Interface Unit (GIU), and Data Transmission System (DTS)). The NTTC-P is the world's first ever electronically shuttered direct-to-digital camera. Tests compared the ASV and 16mm pin-registered film cameras operating at 200 pps to a control set of cameras. Qualitative and quantitative data analysis has determined that the ASV provides results as good as, if not better than, the 16mm film. As a result of these tests, Low Rate Initial Production is underway and orders have been received from the Services to procure the above-mentioned items.

DoD Software Alpha Testbed (DSAT)

The DSAT project, as depicted in Figure 4, focuses on early user, or Alpha testing of information systems software and DoD Mission Applications built around the Defense Information Infrastructure (DII) Common Operating Environment (COE). This includes warfighter/user Alpha testing of rapidly developed command and control (C²) software prototypes made for battlefield usage. The DSAT will also provide for higher levels of C² standards validation, applications integration, and interoperability testing. In addition to strategic and tactical information systems, the DSAT will be used in the Alpha testing of related systems and software products such as intelligence dissemination systems, imagery capture and transport systems, battlefield video and multimedia systems, surveillance systems, and joint battlefield C² systems.

Requirement

Cross-Service consolidation of software-intensive systems will reduce the growing O&M burden on the DoD by removing functional redundancies, establishing a DII COE, and enforcing the use of standards for interfaces and development practices. This is an aggressive consolidation program to reduce the existing legacy systems and systems under development from over 10,000 to just over 200 by the year 2001. These 200 systems are spread over Functional Mission Areas (e.g., Command and Control, Intelligence, Logistics, Communications, Environmental, Security, etc.) that affect all warfighters, regardless of Service. A testing capability does not exist to evaluate a system's DII COE integration for even a single Functional Mission Area.

Traditional, large-scale software development is being abandoned as the methodology of choice within DoD. An increasingly large portion of the software is based on the DII COE. The testing of

the DII COE provided via an automated means is not available anywhere and must be developed.

Description

The DSAT facility provides for the development and demonstration of a standardized testing capability for use in the Alpha test phase of a COE-based applications development. The primary focus of an Alpha Assessment is the integration of Mission Applications to the COE. This integration is conducted primarily within a laboratory environment and is focused on ensuring technical and functional stability of the Mission Application prior to fielding at the operational site.

The DSAT will function as an "instrumented" COE. The instrumentation consists of a comprehensive set of integrated test tools used for analyzing and monitoring the interfaces of systems under test with the COE. This instrumented COE concept parallels the use of Automated Test Equipment in a maintenance shop. The Mission Application can be compared to hardware "least replaceable units" which are plugged into a test fixture for examination. The instrumented COE functions as the test fixture for the Mission Application.

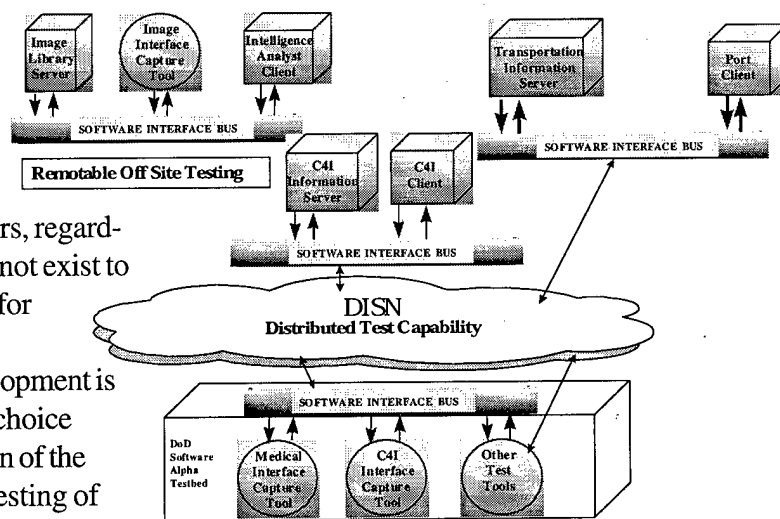

Figure 4. DoD Software Alpha Testbed

Existing policy guidance has resulted in many development and procurement programs implementing software in accordance with the DoD Joint Technical Architecture (JTA)¹ standards. These systems are evolving toward a basis in a COE. The DSAT provides the means to consolidate existing programs and procure or develop additional tools to implement a comprehensive integration, test, and evaluation capability that maximizes the availability of reusable commercial-off-the-shelf and Government-off-the-shelf software components.

Benefits

The DSAT gives all the Services the needed testing environment to efficiently check out their Systems'/Mission Applications' interface and integration to the DII COE, and at the same time enables the early collection of interoperability data for the DoD (DoDD 4630.5 and DoDI 4630.8) and CJCS (CJCSI 6212.01A) mandated Interoperability Certification Program. This results in saving time and money for every Service and earlier fielding of systems.

Schedule

Milestones	FY98	FY99	FY00
DII COE Host Acquisition	x		
CORBA Tool Development	x		
Tool Verification		x	
Environment Integration		x	
Level 7 COE Certification			x
FOC		x	

Progress & Completion

The DSAT is a 3-year project that started in FY96 and has been accomplished in three phases: Phase 1, Define/Design; Phase 2, Prototyping/Initial Acquisition; and Phase 3, Implementation of Capability. The DSAT project is currently in Phase 3. The Joint Interoperability Test Command has provided dedicated space for the DSAT facility and will assume the future O&M and upgrade costs. The DSAT contractual support staff are on board, with testing and technical expertise spanning the various COE platforms. The first complement of testbed equipment, representing the platforms currently certified for COE, has been acquired and installed. Additional platforms, currently in the COE certification process, are being procured and will be in operation in the facility later this year.

An initial product from this effort has been the development of detailed test procedures for the certification of a system to the DII COE Integration and Run Time Specification (I&RTS) up to Level 5. The I&RTS describes the increasing levels of certification to better ensure that DoD systems will be interoperable if they are designed to and implement these standard profiles. In the final Phase of the DSAT development the procedures will be enhanced to include up to Level 7 of the I&RTS checklist.

A highly successful prototype tool was developed during Phase 2 based upon the new software design and development architecture, called Common Object Request Broker Architecture (CORBA). This tool implements a capability to verify software client and server activity during standards validation testing. Phase 3 will enable this tool to be redesigned and made with a more general input/output capability.

¹ - DoD Joint Technical Architecture, 22 Aug 96, Version 1.0.

Electromagnetic Environmental Effects Generating System (E3GS)

The E3GS project will be a multi-Service test facility capable of assessing the actual performance of a full-scale, fixed, or rotary winged aircraft while the aircraft is completely immersed in a user-specified, high intensity, RF environment. The test facility will be capable of generating radar frequency environments over the 10 kHz to 40 GHz frequency range with average field intensity levels of 200 Volts/meter and a peak field intensity of 30,000 V/m. The facility will be part of the Air Combat Environment Test and Evaluation Facility at Patuxent River, Maryland, as are the current installed systems collectively referred to as the Electromagnetic Environment Generating System (EMEGS).

neutral, and hostile sources. Navy ships abound with high-powered radars; foreign air bases are small and contain powerful emitters; European air corridors are frequently in close proximity to radio and TV stations; and the combat airspace itself will naturally be subject to intense electronic activity. More comprehensive E3 testing is required to ensure that military aircraft will meet performance and survivability specifications while operating in a complex EME that includes high power, long duty cycles, and very high peak pulses, all over numerous frequency bands.

Requirement

Military aircraft are required to accomplish their missions in a diverse electromagnetic environment (EME). Joint and coalition forces operating in littoral regions will encounter battle spaces characterized by dense electromagnetic radiation from friendly,

Description

Fully completed, the E3GS, as shown in Figure 5, will consist of five primary systems as follows:

- High Frequency (HF) Broadcast System - Frequency Range 4-30 MHz , 100 kW output, 100 percent duty cycle.

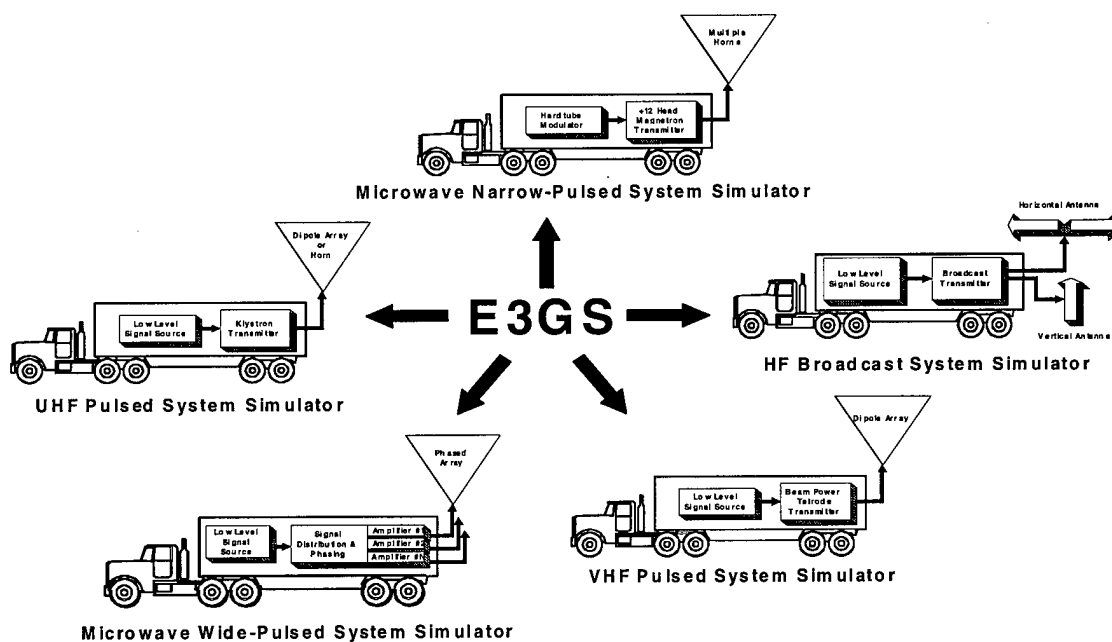

Figure 5. Electromagnetic Environmental Effects Generating System

- Very High Frequency (VHF) Pulsed System - Frequency Range 170 MHz, 400 kW output, 7 percent duty cycle.
- Ultra High Frequency (UHF) Pulsed System - Frequency Range 900 MHz, 400 kW output, 10 percent duty cycle.
- Microwave Narrow Pulsed System - Frequency Range 1 - 40 GHz, 5 MW output, 0.1 percent duty cycle.
- Microwave Wide Pulsed System - Frequency Range 1 - 10 GHz, 1 MW output, 25 percent duty cycle.

To facilitate some of the E3GS features, the design strategy includes provisions, listed below, to support operations for all five systems. This provides subsystem similarity, commonality in operational approach, and ease-of-use on interfacing various test equipment suites into each of the five systems.

- Use of an IEEE-488 instrument bus, RS-232, or Ethernet to facilitate interoperability, commonality, and supportability of all equipment.
- Acquisition and integration of a 1-40 GHz, 5 megawatt hard tube modulator to increase output power, provide for greater frequency coverage, and affect the simulation of actual emitters.
- Acquisition and integration of a 400 kW, 10 percent duty factor high power klystron finals to simulate the UHF radars and to provide higher output power and greater reliability.
- Acquisition and integration of a variety of antennas optimized to radiate aircraft size test articles in the near/far fields and at high power.
- Development and integration of controlling, calibrating, and automated test execution software.

Benefits

The E3GS will provide a comprehensive and broad spectrum test capability that minimizes potential gaps in the electromagnetic environment that may be sources of unknown or unanticipated threat to combat units or to non-military aircraft or airlines. Test time will be shortened and data reduction requirements reduced while the amount of data available for future analysis and/or retrieval will be increased. The E3GS will also reduce aircraft test vehicle ground time and provide for the early identification and correction of deficiencies.

Schedule

Milestones	FY98	FY99	FY00	FY01	FY02
Design	x	x	x	x	x
Design Reviews		x	x	x	x
Fabrication		x	x	x	x
Installation & Integration		x	x	x	x
IOCs			x	x	x
FOC					x

Progress & Completion

Preparation of the program administrative documents and engineering needed for procuring the HF broadcast system was successfully completed. The HF broadcast system requirements were validated against the real-world transmitter sites and aircraft operation. The detailed technical requirements and acquisition documents were prepared for system. The HF broadcast antenna procurement action was started in September 1997. Award of the design phase of the contract was made in February 1998. After completion of a 3-month study of the antenna, the transmitter will be procured.

Foundation Initiative 2010

The Foundation Initiative 2010 project, depicted in Figure 6, is developing and validating the necessary core products to enable the interoperability necessary to create synthetic battle-spaces consisting of actual weapon systems at multiple ranges, system components in hardware-in-the-loop facilities, and/or simulations of weapon systems. Furthermore, through the establishment of a common architecture, reuse of range assets will be furthered.

Requirement

To support the war-fighting community, interoperability and reusability of resources within the T&E community is needed to ensure validated weapon system requirements are satisfied in a cost-effective manner. Resource constraints (safety, funding, environmental, and treaty-compliance) will limit the scope of live testing to a few critical data points or events that may, without complementary modeling and simulation capabilities, result in the fielding of future war-fighting systems that may not be fully understood or effective. Incorporating all design considerations, a simulation-based acquisition process is being adopted by the DoD to reduce time, risk, and cost of development for future weapon systems.

Description

Beginning in FY98, four CTEIP projects (the Test and Training Enabling Architecture; the Common Display, Analysis, and Processing System; the Virtual Test and Training Range; and the Joint Regional Range Complex) were merged to establish the Foundation Initiative 2010 project. The Foundation Initiative is developing and validating a common architecture, a core set of tools, inter-range communication capabilities, interfaces to existing range assets, and a repository of reusable software, along with recommended procedures for conducting synthetic exercises.

The common architecture, referred to as the Test and Training Enabling Architecture (TENA), will be compliant with the DoD High Level Architecture (HLA) for simulations, drastically improving the ability for ranges to interact with simulations.

The core set of tools is a suite of key software applications that assist range engineers in planning, configuring, controlling, and analyzing synthetic and/or multiple range exercises. These TENA-compliant software tools will enhance the productivity of the range engineer so that planning

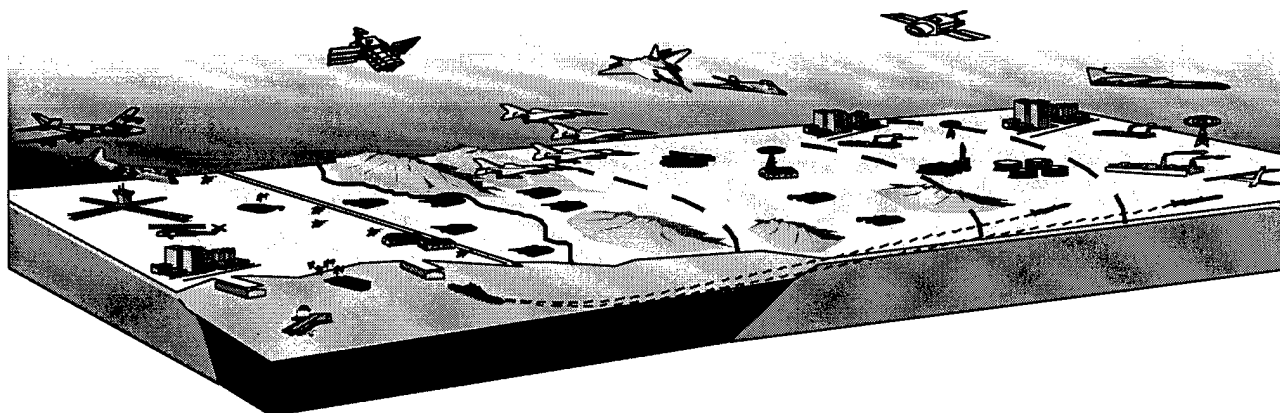

Figure 6. Foundation Initiative 2010

and re-configuring for large-scale synthetic exercises can be accomplished much faster and more reliable than today.

The inter-range communication capabilities will validate that the products developed can function over both organic DoD wide-area networks and commercial communication services; and will also evaluate the necessary end equipment and encryption devices required to transfer large quantities of data between geographically dispersed locations in an TENA-compliant exercise.

The Foundation Initiative 2010 project will also develop necessary interfaces to existing range resources to become TENA-compliant. These interfaces will cost-effectively enable current infrastructure to be adapted to this common architecture rather than require replacement systems to be developed.

The Foundation Initiative will also establish a repository of reusable software components to reduce the cost, time, and risk of future instrumentation developments. It will show how to utilize components in follow-on software applications developed by other projects, and how to develop new components so that they may be added to the repository for future reuse.

Benefits

The overall capabilities of the Foundation Initiative 2010 will promote interoperability and reusability among DoD ranges, facilities, and simulations. These capabilities will advance a simulation-based acquisition methodology to streamline weapon system acquisition. Most importantly, once the

capabilities of the Foundation Initiative 2010 are in use by the test and training communities, future inter-range operations, as well as instrumentation development and sustainment, will cost less and assume less risk.

Schedule

Milestones	FY98	FY99	FY00	FY01	FY02	FY03
TENA Baseline Report	X					
Experiment w/HLA for Ranges	X	X	X	X	X	X
Distributed Visualization		X	X	X	X	X
Distributed Data Archiving			X	X	X	X
Distributed Data Analysis				X	X	X
IOC				X		
DoD Range Interoperability				X	X	X
FOC						X

Progress & Completion

The TENA Baseline Report was delivered to the Range community for review in October 1997. This initial report is being refined to incorporate the recommendations of the Common Test and Training Range Architecture group, which consists of systems engineers from test and training ranges and facilities. Several alliances have been initiated to leverage the efforts from other related activities such as the Defense Modeling and Simulation Office (DMSO), the Joint Advanced Distributed Simulation Prototype Virtual Range (see page 27), the Transportable Range Augmentation and Control System (see page 45), and the Advanced Multiple Object Acquisition System (see page 53). A risk reduction exercise with three scenarios is being conducted in FY98 to determine the suitability of the HLA to satisfy range requirements.

Hardened Subminiature Telemetry and Sensor System (HSTSS)

The HSTSS project will develop and demonstrate a new generation of rugged, miniaturized, on-board instrumentation measurement technologies applicable to weapon system flight tests. The technologies will be relatively low-cost and will consist of several configurations designed to accommodate applications in the direct fire, indirect fire, and missile system mission areas. A depiction of the objective system as it may be applied to a kinetic energy projectile is shown in Figure 7.

Requirement

Comprehensive measurement devices do not exist for very high-G projectile systems. Specific weapon system performance data such as acceleration, roll, pitch and yaw rates, pointing angle at detonation, launch pressure on projectile base, and internal functioning currently cannot be collected routinely, efficiently, or cost effectively at DoD test

ranges. Therefore, the need exists to develop new methodologies and hardware to capture these measurements in a high-G environment in support of direct fire, indirect fire, and short range air defense weapons. The device must provide continuous data from launch to impact, be nonintrusive to the unit-under-test, have a self-contained power source, and use standard transmission formats.

Description

HSTSS is the development of a system that will provide direct measurements from launch to impact for a wide variety of munitions systems. It will be used to measure parameters such as attitude, velocities, accelerations, temperatures, pressures, internal processor functions, and sensor functions. This data will be telemetered to a standard range ground station and data analysis center. The system will have configurations unique

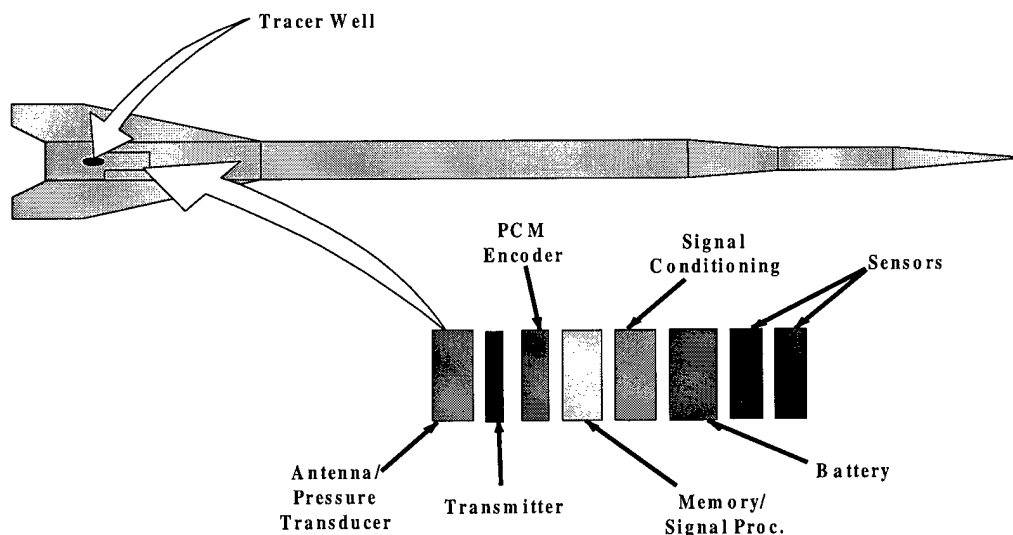

Figure 7. Hardened Subminiature Telemetry and Sensor System

to the host test articles and will not interfere with their static and dynamic performance characteristics. The system will have a modular design consisting of power source, various sensors, data acquisition module, signal conditioning module, transmitter, and antennas.

Benefits

The HSTSS project will provide the Army, Navy, and Air Force with an entirely new high-G instrumentation capability. The characteristics of the HSTSS devices, which are small and low power by nature and inexpensive, will provide attractive features to lower-G systems such as missiles and smart bombs, where space and power limitations are severe.

Advanced technologies used in the HSTSS project include lithium-ion polymer flexible power supplies, hardened L- and S-band transmitters, antennas, multi-chip modules, micro-electromechanical sensors, and inertial measurement units.

Schedule

Milestones	FY98	FY99	FY00	FY01	FY02
1st Contract Award	x				
System Test & Evaluation		x			
Prototype Construction		x x x			
IOC				x	
2nd Contract Award		x			
FOC					x

Progress & Completion

HSTSS currently has a contract in place to study a Global Positioning System/Inertial Measurement Unit for onboard use. A high-G miniature transmitter contract has also been awarded. Prototype construction will begin in the second quarter of FY99.

High Speed Massive Memory/Electronic Film Capability (HSMM/EFC)

HSMM/EFC, represented in Figure 8, will produce a very high speed and high capacity electronic media storage device that will capture data from high resolution staring arrays.

Requirements

The current generation of large format focal plane staring array (FPSA) cameras now produce data at a rate much faster than current storage schemes can accommodate. Additionally, ongoing dependence upon film to record test events is costly and time consuming. Limitations of the medium in the framing rate of large format film (greater than 35mm) results in loss of event and time-space-position-information

(TSPI) data. Film data reduction can be inaccurate as well.

The baseline requirement for the HSMM/EFC project is to provide a high-speed storage medium capable of acquiring data from a FPSA in real time, which will permit the elimination of film for at least 90 percent of test and evaluation applications and result in rapid turnaround in data reduction, with a goal of 1 hour. The system is also required to integrate with real-time, generator-based, constructive simulations. Film cannot contribute to real-time situational awareness of real-time image, generator-based, constructive simulations.

Description

The HSMM project will provide a high-speed and high-intensity storage medium capable of acquiring data from a FPSA in real time. An array of high-speed electronic film cameras (EFCs) will be integrated with the HSMM for the collection of test data. The HSMM will be modular in design and be equipped with flexible and adaptable interfaces to permit operation with existing communications, sensor, and instrumentation systems at Service ranges. Extensive reuse of previously-developed hardware and software components will receive major emphasis in the development of HSMM

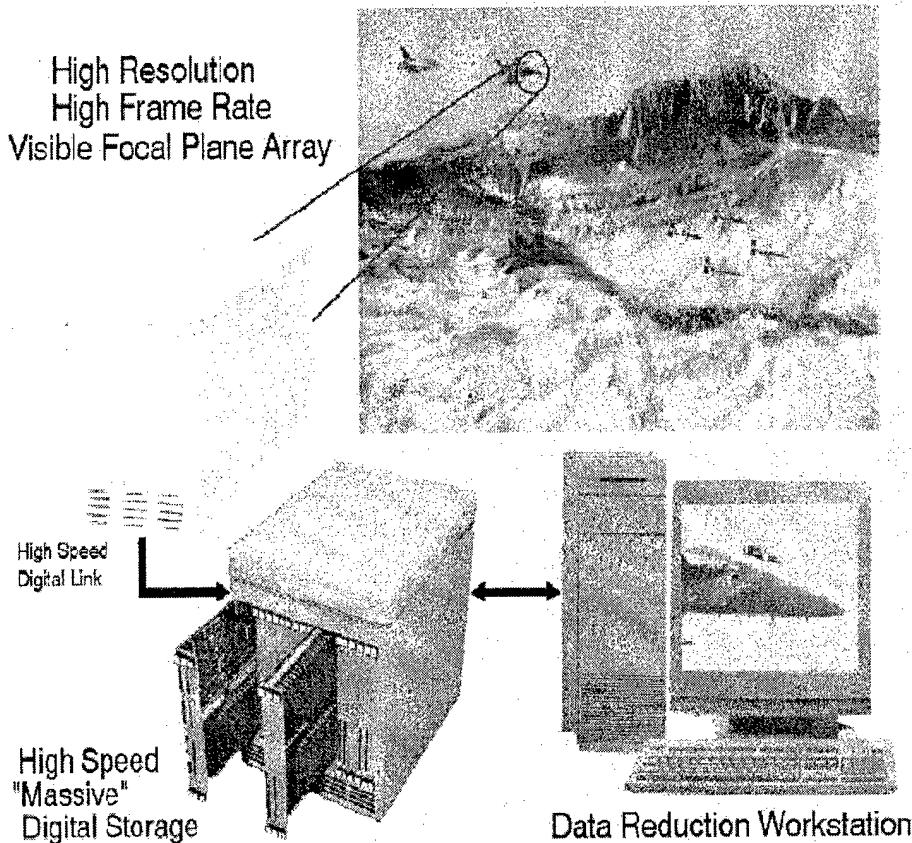

Figure 8. High Speed Massive Memory/Electronic Film Capability

The objective of the HSMM/EFC project is to design, develop, and deliver "starter kits" to the Army, Navy, and Air Force consisting of three high-density, high-frame-rate FPSAs; three 800 Mb per second, 20 Gb capacity DRAM storage devices; and one automated data reduction station.

Benefits

The HSMM/EFC system will eliminate film for at least 90 percent of DoD T&E applications. Real-time situational awareness will be available at extreme resolution and frame rates as high as 600 frames per second. Remote and reliable operation will be provided with rapid 1-hour turnaround in data reduction. Storage, retrieval, and archiving of data will be improved, while caustic, film-processing chemicals harmful to the environment will be eliminated. The mature technology being applied to the project should ensure immediate cost savings with the added benefit of both short- and long-term positive environmental implications

Schedule

Milestones	FY98	FY99	FY00
Design	X X		
Critical Design Review	X		
Prototype Construction	X X	X X X X	
IOC			X
FOC			X

Progress & Completion

During FY98, a thorough review of HSSM requirements will be conducted. The requirements of other CTEIP-funded projects will be reviewed along with Service requirements that may augment or change the technical approach to HSMM. A formal assessment of technologies intended for use by HSSM will also take place to specifically address the use of large format, high rate frame sensors, massive solid state memory devices, and datalinks to integrate the sensor to the massive memory. Based upon this assessment, a prototype will be assembled and demonstrated by the end of FY99.

Joint Advanced Distributed Simulation (JADS) Prototype Virtual Range (PVR)

The JADS PVR (see Figure 9) project is improving the interoperability and interconnectivity among test centers, ranges, and facilities by establishing communications between test facilities and evaluating the capabilities of the networks. It is identifying the constraints and methodologies related to linking test facilities and identifying the requirements for future capabilities.

Requirement

The test and evaluation (T&E) community is faced with reduced funding and the requirement to test and field new, more advanced, and

interoperable weapons systems. Under current and future budget constraints, the T&E community needs advanced, more cost-effective test methodologies to provide the necessary capabilities for these upcoming systems. The Defense Science Board concluded in a 1992 study that the DoD should use distributed simulation to fully link test ranges and facilities, training ranges, laboratories, and other simulation activities to improve testing and training. Advanced Distributed Simulation (ADS) uses rapidly evolving information systems technology to link ranges, laboratories, and simulations at multiple locations to create realistic, complex, synthetic environments which can be used for test and training purposes.

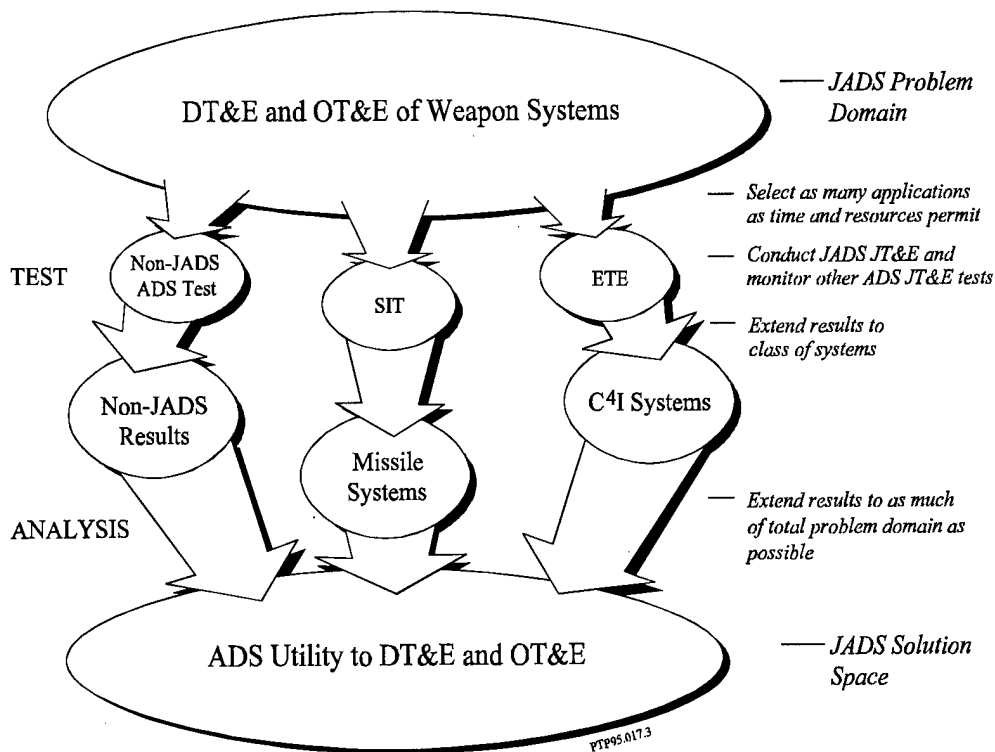

g

D

Figure 9. JADS Test Concept



Description

JADS is directly investigating ADS applications in three slices of the T&E spectrum: a System Integration Test (SIT), which explores ADS support of guided missile testing; an end-to-end (ETE) test, which explores ADS support for Command, Control, Communications, Computers and Intelligence Surveillance and Reconnaissance (C⁴ISR) testing; and an electronic warfare (EW) test, which explores ADS support for EW testing. The focus of the JADS PVR project is to provide the communication networks needed to support the SIT, ETE, and EW tests. For the SIT, this included the purchase of communication network equipment, the leasing of communication lines, and the development of reusable communication interface software. The ETE test is investigating and prototyping the capability to link a live aircraft into a virtual environment using satellite communications capabilities and will also reuse equipment and software developed in the SIT. For the EW test, additional networking equipment is being purchased, communication lines are being leased, and High Level Architecture compatible communication interface software is being developed.

Benefits

The overall result of the JADS PVR project will be several prototype virtual ranges which the test community can expand and extend based on JADS findings. All the test facilities will have communications nodes which can be reused to support further

prototypes or actual test requirements. The prototype virtual ranges can serve as testbeds for future Foundation Initiative 2010 exercises (see page 21) and support the CTEIP architecture development efforts.

Schedule

Milestones	FY98	FY99	FY00	FY01	FY02
ETE TEST					
ETE Satcom Interface					
Software Development	x	x	x		
HW Setup & Test		x	x		
Lab System Test		x			
Aircraft Test			x		
ETE Network Support			x	x	x
EW Test					
Network IOC		x			
Test Execution			x	x	x
Network Deactivation				x	

Progress & Completion

The SIT was completed in October 1997. Many significant lessons were learned concerning communications network setup, instrumentation, network interface device performance tuning, and latency and bandwidth performance. Procedures and software were developed to support network setup, characterization, performance monitoring, and data logging. Hardware, procedures, and software are now being reused to support the ETE test. Procedures and software are being shared with other joint test programs and other service test programs which are using distributed testing.

Joint Advanced Missile Instrumentation (JAMI)

Note: This project is also receiving TTD&D funding.

The JAMI project will develop an integrated instrumentation package for tri-Service small missile test and training applications. Components developed through this effort (see Figure 10) will provide telemetry, time-space-position information (TSPI), flight termination, and end-game scoring in a low-cost, modular package that will allow world-wide test and training, thereby eliminating, in most cases, the need for range-specific (or multi-system) facilities. JAMI will incorporate Global Positioning System (GPS) based technology as the TSPI and vector scoring engine, state-of-the-art telemetry, and an off-the-shelf ultra high frequency flight termination receiver coupled with a solid state programmable safe and arm (S&A) device. All components will be qualified and tested as an integrated package in a missile system flight test.

Requirement

For test and training applications, missiles such as the Advanced Medium Range Air-to-Air Missile (AMRAAM), Rolling Airframe Missile (RAM), Standard Missile, and the Evolved Sea Sparrow Missile (ESSM) must be instrumented to provide

four range functions: telemetry (TM), TSPI, flight termination and end-game scoring. There is a need for the development of JAMI because (1) currently, there is no single, airborne instrumentation package that supports all four functions; (2) the instrumentation that does exist is range-specific; and (3) a cost-effective solution is needed for older technology end-game scoring systems. JAMI will have applicability to tri-Service small missile programs.

Description

A two-phased TTD&D approach is planned. Phase 1 will validate the end-game scoring accuracy requirement and evaluate existing GPS low-cost hardware to determine the accuracy and dynamic robustness of existing receivers. Phase 2 will investigate the applicability of advanced conformal antenna technology to provide a high performance multi-band antenna subsystem, and the achievable performance and complexity of alternative kinematic processing techniques will also be investigated.

The JAMI JIM effort consists of several component development initiatives and one or

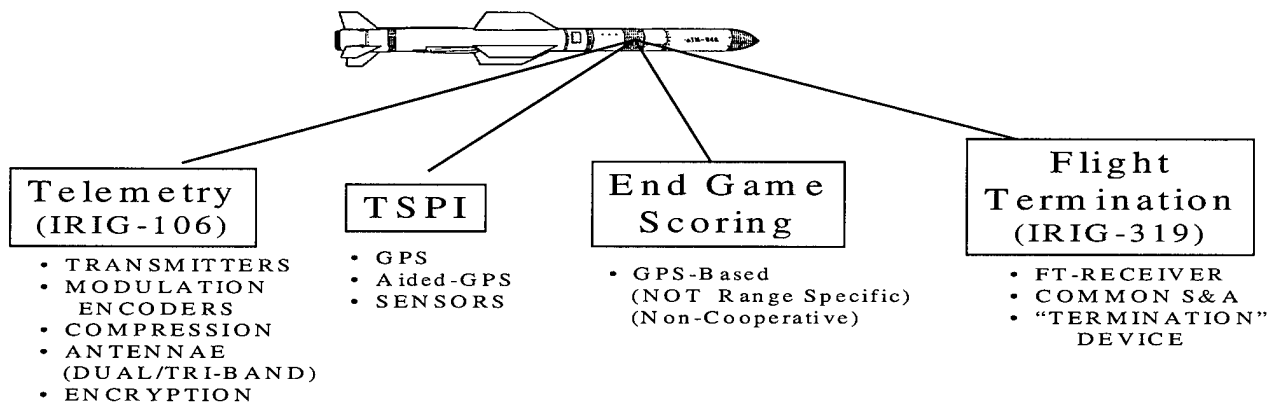

Figure 10. Joint Advanced Missile Instrumentation

more missile integration demonstrations. The JAMI project will concentrate on the development of pre-qualified instrumentation, TSPI tracking, scoring, and flight termination system (FTS) components and will demonstrate several of these components in an integrated package. A goal for the FTS is the development of miniature, dual, redundant hardware that can be pre-qualified to levels which envelope existing missile environmental levels. Another product to be delivered is a design toolbox. This toolbox will be an electronic database that includes information on JAMI qualified hardware, qualification test reports, TM system design tools such as range TM link calculations, and programmable component interfaces.

Benefits

JAMI will provide added capability to track low-flying targets and missiles that fly below the radar horizon. This will reduce the range safety risk by providing accurate tracking throughout the duration of the flight. Test cost savings may result due to alleviation of the need to clear a large range area. JAMI components will enhance interoperability by reducing the need for unique range infrastructure systems. JAMI will rely on common range telemetry equipment for data transfer from the missile to the ground. GPS-based TSPI will reduce and in many cases eliminate the requirement for ground-based radar.

Progress & Completion

As part of TTD&D Phase 1, an assessment is being made of the achievable accuracy of existing GPS technology without resorting to kinematic techniques. Vendors are being surveyed, and promising off-the-shelf components are being

investigated. Two tests were conducted in FY97 using commercially available receivers on a supersonic track vehicle. In the first test, a power supply failure limited the solution to the first three seconds of flight. The results of the first test indicated that the GPS receiver was able to track through the high jerk of ignition and maintain track through the first three seconds, at which time power was lost. In the second test, Ashtech, Inc. G12 and GG24 receivers were used, and their position data was compared to ground truth. The position solutions were better than the first test; however, complete data analysis has not yet been completed.

The second major area of emphasis during TTD&D is the development of an antenna system to support the instrumentation. Radio frequency evaluation of a wrap-around GPS antenna is underway. A second prototype antenna will be received and evaluated during FY98. In addition, a specification will be prepared for the acquisition of a flight termination system utilizing a dual-redundant, miniaturized S&A device. By the end of FY98, a "sources sought" procurement action will be initiated to determine industry interest and to solicit comments on the specification.

Schedule

Milestone	FY98	FY99	FY00	FY01	FY02	FY03
TSPI Requirements Definition	x	x	x	x		
TSPI Contract Award				x		
TSPI Component Qualification				x	x	x
End-Game Scoring Requirements Def.			x	x	x	x
End-Game Scoring Contract Award					x	
End-Game Scoring Component Qual.					x	x
Flight Termination System Req. Definition	x	x	x			
Flight Termination System Contract Award			x			
Flight Termination Sys. Component Qual.			x	x	x	
TSPI Component Testing		x		x		
End-Game Scoring System Testing					x	
Flight Termination System Testing				x		
Platform Integration Testing (Missile TBD)						x
JAMI IOC						x

Joint Installed Test Facility (JISTF) Upgrades

To meet increasing test and evaluation requirements, DoD has supported joint Navy and Air Force efforts to develop integrated electronic combat ground test facilities. These facilities, based on computer-controlled simulators and stimulators, can present high fidelity background, threat, and target environments to the weapon system and the flight platform under test and measure the resulting impacts and actions of the on-board systems in response to the stimuli.

The JISTF subprojects include development of multi-spectral stimulators for various Air Force, Navy, and Army ground test facilities. The stimulators, taken individually, span separate areas of the electromagnetic spectra and fulfill differing technical requirements. However, sufficient programmatic and technical commonality exist to justify grouping the development of these stimulators under a single JISTF Upgrade project as pictured in Figure 11.

Both Service and CTEIP funding is being used to upgrade capabilities at two different, but complementary, Installed Systems Test Facilities (ISTF): the Navy's Air Combat Environment Test and Evaluation Facility (ACETEF), Naval Air Warfare Center Aircraft Division, Patuxent River, Maryland; and the Avionics Test and Integration Complex (ATIC) Air Force Flight Test Center, Edwards AFB, California. The Navy is constructing a large, more advanced anechoic chamber to be integrated with ACETEF's existing ISTF capability, while the Air Force is developing the core infrastructure, simulation, and stimulation capabilities necessary to develop an ISTF within the ATIC.

Requirement

With the increasing complexity of electronic combat over the past decade, more sophisticated test and evaluation has been required to ensure that U.S. combat systems can effectively operate within their own generated electronic environment and

against the multi-spectral radio frequency (RF) and electro-optical threat presented by an enemy. Newer aircraft systems with advanced, highly integrated, software-intensive avionics, such as the F-22, B-2, and F-18 upgrades, are requiring increasingly complex test and evaluation facilities. These facilities must be able to test a fully integrated aircraft in multi-spectral environments including targets, threats, and background.

Description

Four major projects have been defined and funded based on critical need and the ability to meet requirements with a common system: the Generic Radar Target Generator (GRTG); the Infrared Sensor Stimulator (IRSS); the Multi-Spectral Scene Generation (MSSG) subproject; and the Communications, Navigation, Identification (CNI) Simulator.

The GRTG will present dynamic, multiple, angle-of-arrival target and surface clutter radar returns to a system under test. The capability will be able to support both free space RF targets as well as permit direct RF signal injection. The Air Force has been designated the lead for this effort.

The IRSS will provide a high fidelity scene projector for infrared (IR) search and track, missile warning, and forward-looking IR. Capa-



Figure 11. JISTF Upgrade

bilities will include the ability to stimulate both point source and imaging sensors through a combination of free space projection and direct IR digital signal injection. The Navy has been assigned as the lead for this project.

The MSSG will provide a high fidelity scene projector for testing multi-mode (IR/RF/MMW) missile seekers. Capabilities to be developed include presentation of IR targets, background, and countermeasures signals through the use of high and low frequency beam combiners, IR scene generators, and IR scene projectors. This project has been assigned to the Navy and will incorporate work begun under space-based IR technology development and system development at the Naval Air Warfare Center Weapons Division, China Lake, California; the U.S. Army Missile Command, Redstone Technical Test Center, Alabama; and the Guided Weapons Evaluation Facility, Eglin AFB, Florida.

The CNI project will provide a wide range of high-fidelity friendly and threat signals for testing a variety of weapon systems. The simulator will incorporate both a strategic datalink simulator and a communications environment simulator for open-loop and closed-loop testing capabilities. The Navy has been assigned the lead for this project.

Benefits

DoD has pursued and funded activities designed to achieve improved installed systems test capabilities in a timely manner to meet projected test requirements for existing and emerging weapon systems. The ability to ground-test sophisticated weapon systems in an integrated test environment within an installed systems testing facility is absolutely necessary for effective and efficient hardware development and testing. The joint development and management approach implemented by DoD strives to maximize common-

ality between the two premier advanced electronic ground-test facilities, while electronic linking eliminates unwarranted duplication.

Schedule

Milestones	FY98			FY99			FY00		
MSSG Development	X	X	X	X	X	X			
MSSG IOC				X					
MSSG FOC							X		
IRSS Development	X	X	X	X	X	X			
IRSS IOC		X							
IRSS FOC							X		
GRTG Development	X	X	X	X	X	X	X	X	
GRTG IOC							X		
GRTG FOC									X
CNI Development	X	X	X	X	X	X	X		
CNI FOC							X		
JISTF FOC									X

Progress & Completion

During FY97 significant progress has been made in each of the JISTF subprojects. The GRTG development contract has been awarded and development is well underway to meet requirements for B-1 support in FY99 and F-22/F-18E/F testing in FY00. Development of the IRSS Scene Generation System (SGS) capability has resulted in prototype SGS software and hardware. The Joint Data Link Simulator (JDLS) is nearing completion and is in the final integration and test phases. The Joint Communicator Simulator (JCS) has passed through Preliminary Design Review with Critical Design Review in early FY98. Hardware has been purchased and system software is under development. The MSSG subproject has seen the delivery of beam combiner hardware, and development continues on schedule.

Magnetic Levitation (MAGLEV) Upgrade

The Holloman High Speed Test Track (HHSTT) of the 846th Test Squadron, 46th Test Group, Holloman AFB, New Mexico, has been designated the test base for Theater Missile Defense (TMD) lethality testing. Current lethality testing is limited to 2.2 km/sec, which is the low end of the intercept envelope. Realistic testing requires higher impact velocities. This project develops this capability using magnetic levitation (MAGLEV) to control rocket-propelled sleds on a facility adjacent to the HHSTT.

Requirement

Proliferation of theater range ballistic missiles like the SCUD has led to the development of systems to defend against this threat. Lethality of these defensive systems must be evaluated to make acquisition decisions and to support wartime defensive planning. The HHSTT

currently provides hypersonic impact testing capability for various Air Force, Navy, and Army TMD programs. Present customer hypervelocity impact-velocity requirements exceed existing capability. Development of top priority, TMD interceptors without validation of their lethality results in major technical risk that the U.S. would field defensive systems which are ineffective against chemical and biological weapons. The MAGLEV Upgrade to the HHSTT will provide this additional impact-velocity requirement, allowing for relatively inexpensive testing to validate TMD interceptor lethality. Weapon systems in development currently requiring lethality testing include Theater High Altitude Area Defense (THAAD), Patriot Advanced Concepts III (PAC III), Standard Missile II (SM-II) Block IV Upgrade, and SM-II (LEAP). Future weapons will also require this capability.

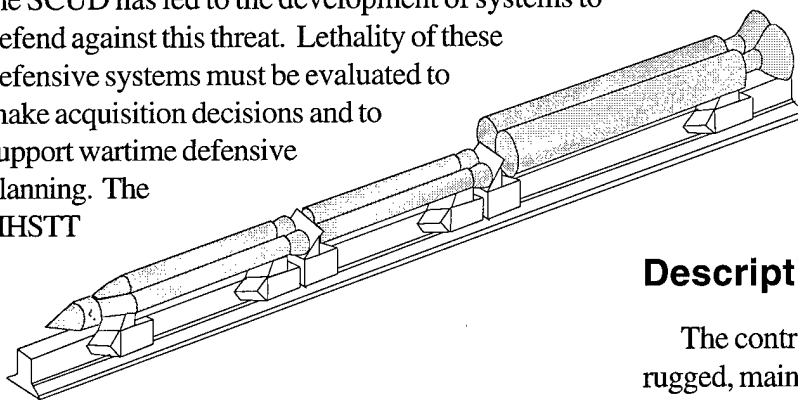

Figure 12.1 MAGLEV Baseline Design

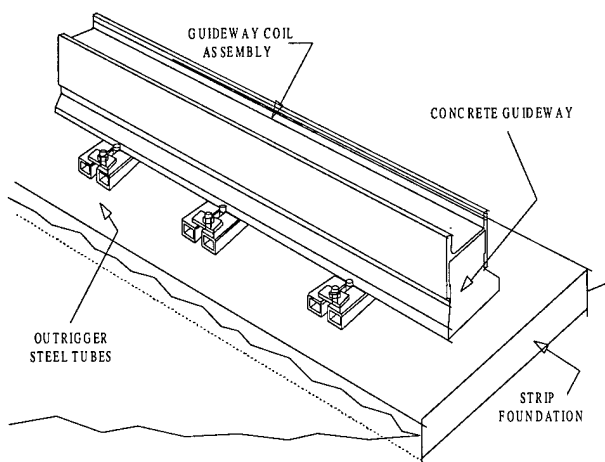

Figure 12.2 Guideway Design

Description

The contractor has developed a simple, rugged, maintainable, and low-cost MAGLEV system, designed to meet the program requirements, specifically to achieve 3 km/sec with a 25 kg payload. The concept utilizes a sled train consisting of three stages as depicted in Figure 12.1. This design requires the use of two wings and coils both fore and aft of the rocket motor. The guideway structure is to be constructed of stainless steel, fiber-reinforced concrete as shown in Figure 12.2.

The design is based upon passive, inherently stable repulsive-force magnetic levitation of the test sled. The levitation force is generated as the liquid helium cooled wings, containing superconducting magnets, pass over the triple null-flux coils. Based on aerodynamic and magnetic

analyses, a design was developed that wraps around a single guideway structure. The coils, which are molded in the shape of saddlebags, are located on top of the guideway and are fixed with bolts. In addition to the null-flux coils, the design includes braking coils and a 308m section of electromagnetic propulsion drive coils. The levitation and braking coils are contained in the saddlebag structure located on top of the guideway. The saddlebag structures contain two turn coils with leads out to a brake assembly contactor box. When a sled passes over a section of guideway, the contactor closes, causing trailing sled sections to experience an electromagnetic braking force from the now closed braking coil. The electromagnetic propulsion consists of sets of three phase serpentine windings incorporated into a 308m section of the guideway. A 12 MVA inverter driven from a battery power source will deliver 18 kA peak to provide 40 kN of force to a sled containing eight wing coils.

Benefits

A HHSTT upgrade Test Capability Benefits Analysis (TCBA) was completed in June 1996, by the Georgia Tech Research Institute. The TCBA considered three alternatives to meet the need of test velocities in the 3 km/sec-plus range with lower vibrations: MAGLEV Upgrade, Enhanced MAGLEV Upgrade, Conventional Upgrade. The difference between the MAGLEV and the Enhanced MAGLEV Upgrades, is that the latter has the option for a guideway extension of 50 percent over the 10 kilometer MAGLEV Upgrade. The Conventional Upgrade consists of extending one rail of the current track and significantly extending the length of the helium bag used. The Conventional Upgrade could allow for test velocities up to 2.8 km/sec with no reduction in vibration. The conclusion of the

study was that the MAGLEV Upgrade is superior to the other alternatives considered, while providing the maximum utility for cost.

Schedule

Milestones	FY98	FY99	FY00	FY01	FY02	FY03
EMD Design Complete	x					
Fab. and Install.	x	x	x	x	x	
2km Demonstration			x	x	x	
IOC			x			
Fab. and Install.			x	x	x	x
Test					x	x
FOC						x

Progress & Completion

In the past year, progress has been made in the validation of the MAGLEV system design. Fabrication of a full-scale MAGLEV test item has been completed, which includes two working superconducting magnets. Several new factors, however, have recently surfaced. While the MAGLEV concept is technically feasible, the manufacturing processes and materials available within current technologies may make testing too expensive. Furthermore, advances in conventional technology have the potential to permit conventional modifications to the track, which may provide increases in test velocities. In view of these developments, the Air Force has requested the Scientific Advisory Board (SAB) to assist in an evaluation of applicable manufacturing processes to determine if the MAGLEV concept is an affordable solution that can be fielded in the near-term. A recommendation from the SAB is expected in mid-FY98, at which time the decision will be made whether to continue with MAGLEV development or to seek a conventional upgrade to the Holloman High Speed Test Track.

Multi-Service Target Control System (MSTCS)

The goal of the MSTC System project is to upgrade existing tri-Service target control systems while providing tri-Service interoperability. The MSTC System, as shown in Figure 13, will build upon the work accomplished by the Next Generation Target Control System (NGTCS) project, which was canceled in FY98 because the chosen approach proved too costly to implement.

Requirement

In testing and training scenarios, it is necessary to present multiple target configurations of both surface and aerial targets in an electronically dense environ-

ment. Creating and controlling these scenarios has taxed target control systems to the point where some are unable to cope with current test and evaluation and training scenarios and are wholly inadequate for meeting future requirements.

Currently, there are a variety of target control systems (TCS) employed on ranges around the world. Each of these systems performs similar functions and may control the same classes of targets; however, they are not interchangeable and do not permit direct interoperability. Each of the principal ranges offers some unique environmental features which make target interoperability

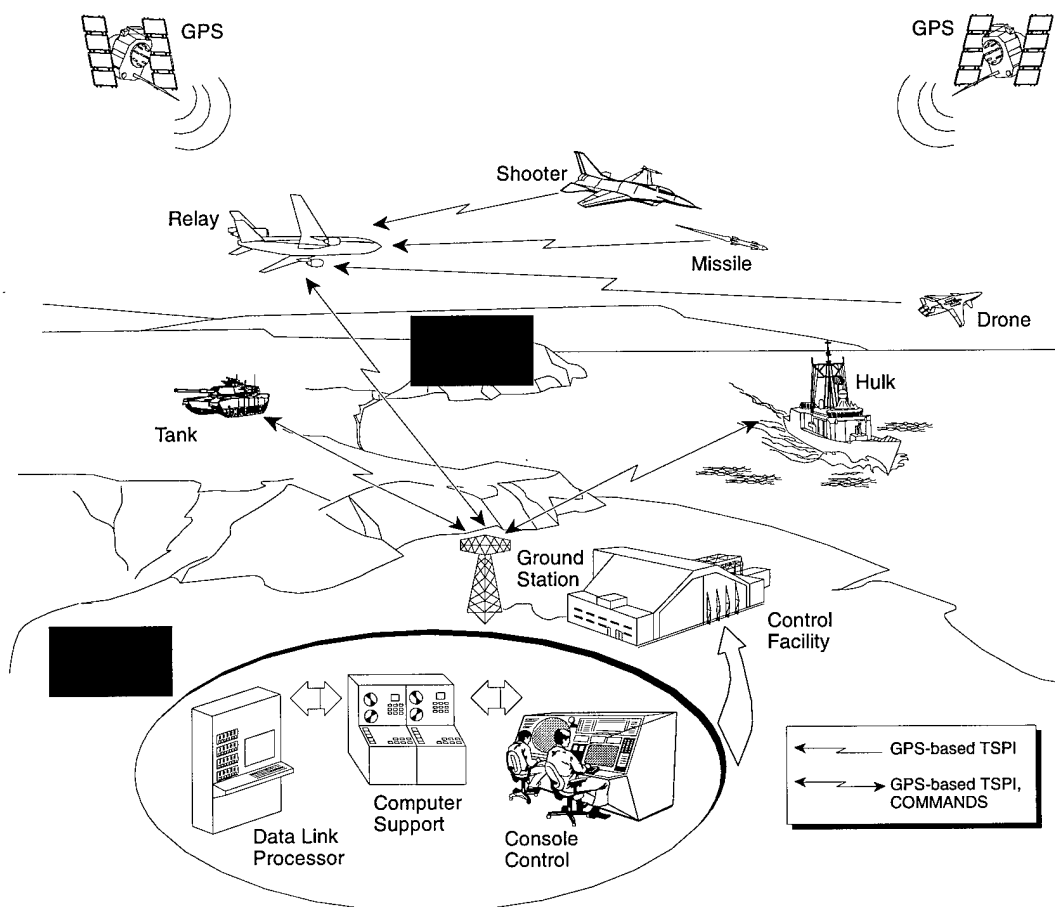
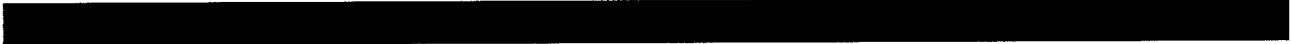

Figure 13. Multi-Service Target Control System



desirable. There is also a need to immediately upgrade deficient TCS and to improve future supportability of all such systems.

Description

The MSTC System consists of three fundamental building blocks. A Global Positioning System-based transponder or third generation time-space-position-information (TSPI) that will provide operational and performance advantages over existing TSPI techniques; a radio frequency link that will pass data in a manner that is spectrally efficient and reliable; and an interoperable ground system that will improve on existing ground systems.

Because the legacy system used by the Navy is radar-based and differs significantly from those of the Army and Air Force, the MSTC System will be developed through two independent efforts, the first of which will be a combined Army and Air Force development of the data link and transponder. The second effort will address the requirements of the Navy and focus on the development of a ground system and interim data link.

Benefits

The MSTC System will provide more capability than each of the Services' existing target control systems and will be in use for many years before the next major target control system upgrade. To maximize its utility, while minimizing premature obsolescence, it will be designed with the newest technology available.

Schedule

The MSTC effort is still in the formative stages. A schedule for its accomplishment will be developed as enabling technologies are identified.

Progress & Completion

The two development phases mentioned above will come together to provide an interoperable system 3 to 4 years after the project is initiated. The ground system for an interim MSTC should be in place in about 2 years and then continue to evolve into a full interoperable MSTC system.



Plume Measurement Capability Facility (PMCF)

The goal of the PMCF project is to develop and construct a test facility that simultaneously measures a rocket motor's performance and its plume signature with respect to radar reflection, and infrared (IR)/ultraviolet (UV)/visible electromagnetic radiation.

Requirement

Modern weapons and weapon system platforms use sensors to measure target signatures. These systems use the output of the signature sensors to identify potential threats and guide weapons to attack the identified threat. Plumes generated by a weapon system's rocket motor can have a substantial effect on the system's overall signature. Accurate correlated signature data is required to design warning systems, seekers, sensors, and countermeasures and to validate target vehicles. In addition, the

drive to develop more stealthy weapons has resulted in an effort to reduce plume signatures; thus, there is a need during rocket motor development or improvement programs to measure plume signatures.

Description

The PMCF, as shown in Figure 14, consists of a centrally-located rocket motor firing pad that is at a higher elevation than the surrounding sensor sites. The firing pad contains significant instrumentation to fully characterize rocket motor performance, including thrust which is measured via a Six Degree of Freedom test stand. This stand can resolve the total thrust vector regardless of rocket motor orientation or off-axis thrust generated by a thrust vector control mechanism in the rocket motor. Stationed at lower elevations are a number

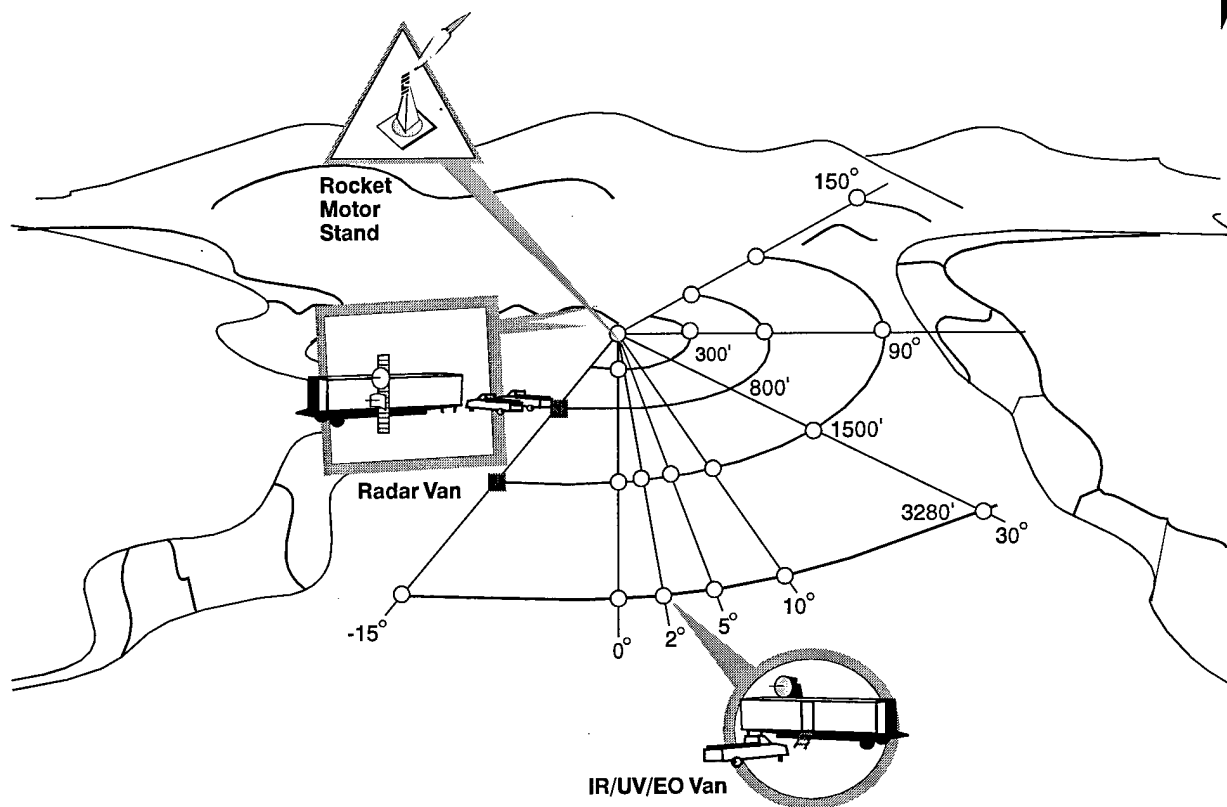

Figure 14. Plume Measurement Capability

of instrumentation pads that contain power, timing, communications, control, and data transmission capability to accommodate almost any sensor system. In addition, two radar systems and several IR/UV/visible electromagnetic sensors were developed and are available to acquire signature data of rocket motor plumes. Many of the instrumented pads provide clear northern blue sky backgrounds that minimize noise/clutter for the IR/UV systems.

Benefits

The PMCF is the only facility capable of concurrent measurement of Radar Cross Section (RCS), electro-optical signature, and motor performance. Because it is an open air, static facility, the cost of conducting test is very low when compared to flight testing, sled testing, or test conducted in chambers. Static tests make the precise control of geometry and other test factors easy when compared to other types of testing. Thus, the PMCF allows the collection of a broad spectrum of data and a very low cost per test, making testing at the PMCF very cost-effective. At the same time, unique instrumentation is available, such as the Six Degree of Freedom test stand and the low power Fast Linear Plume Radar (FLPR) which can be used for transmittance and scattering measurement in addition to RCS. The PMCF is an extremely flexible facility able to support a variety of test scenarios other than just measuring rocket plumes. Adding to the flexibility are the remote location, very high explosive limits, and a favorable environmental compliance situation. There is no population intrusion problem, making security issues easy to resolve. Controlled air space allows the possibility of a combination

ground/flight test scenario. The instrumentation system design allows easy connectivity, so that a test may be controlled from or data may be viewed at locations anywhere in the world.

Schedule

Milestones	FY98	FY99	FY00	FY01	FY02
IOC	x				
Equipment Upgrades		x x x			
Demonstration Testing		x x			
FOC			x		

Progress & Completion

The PMCF is essentially complete. The Six Degree of Freedom test stand is being installed and was completed in December 1997. Final shakedown testing was completed in January, with Initial Operating Capability (IOC) in February 1998. The installation and shakedown tests were conducted with carryover FY97 funds. IOC was delayed because the vendor was 3 months behind in delivery of the test stand. A final report will follow after the completion of the shake down test and analysis of the test results. Full operating capability (FOC) will follow the installation of deferred instrumentation and demonstration testing now scheduled for FY99. After IOC, the PMCF will be added to the facilities operated by the Ballistic Test Branch at Naval Air Warfare Center Weapons Division, China Lake, California. The Ballistic Test Branch operates a wide variety of tactical and strategic rocket motor test facilities and the plume facility will fit well into the normal operating procedures and processes established and followed by that organization.

Target Systems Modeling and Simulation (TSMS)

The TSMS project objective is to develop a Generic Target Model (GTM) "template" (depicted in Figure 15) that will establish a common structure for development of reusable models and provide linkages between databases of target systems data, test results, and model components and algorithms.

between organizations that develop and use models and simulations is minimal, resulting in products that are developed for specific purposes and not readily reusable for other applications.

Requirement

There is a need throughout the testing community for coordinated, simulation development efforts and for commonality between target and threat hardware and simulations. Commonality is needed to reduce the time and resources required to provide target simulations to meet specific test objectives. Currently, there are multiple, uncoordinated development efforts of simulations for the same target type with no common structure and with independent validation and data collection efforts. Coordination

Description

The TSMS project will provide a GTM "template" to support the CTEIP objective of developing, validating, and integrating modeling and simulation with open-air testing to provide timely, accurate, and cost-effective results. The product will consist of a set of models and simulations that are common between target and threat models, target platforms and threat simulators, and sub-components. This commonality will assure validity of test and simulation results and interoperability of threat, simulator, and target models. The template will be designed to support testing and training at

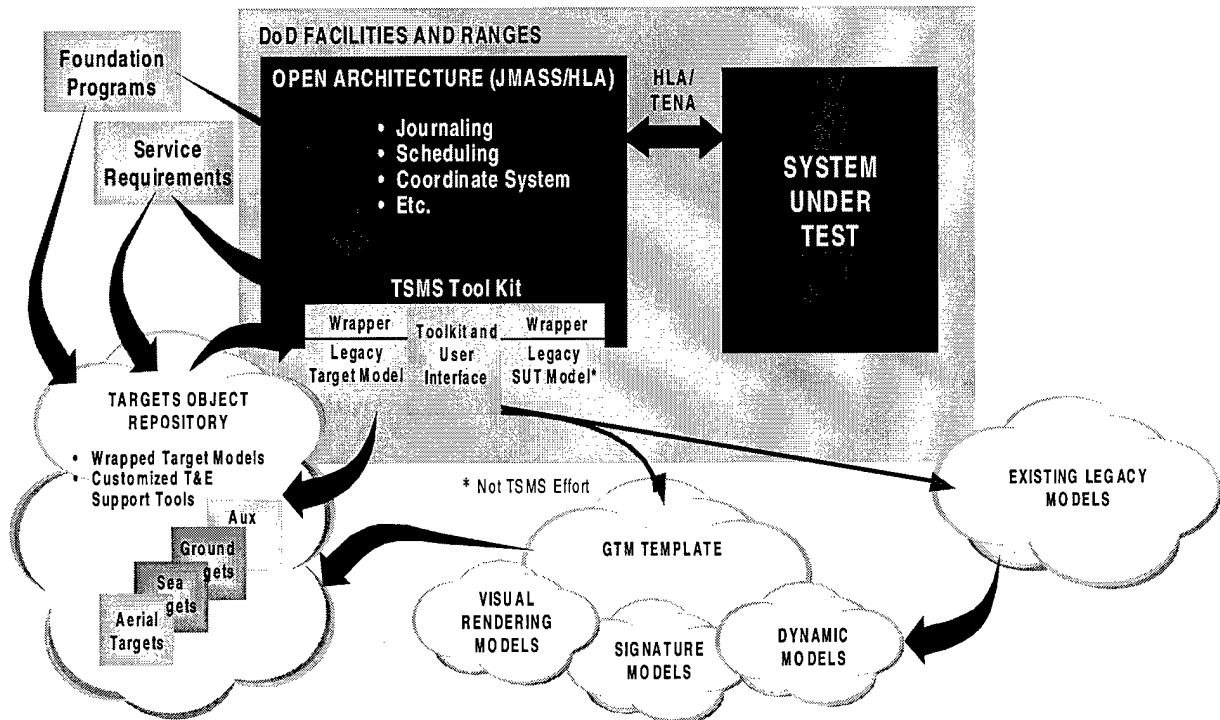

Figure 15. Target Systems Modeling and Simulation Template

DoD ranges, and will use object-oriented design principles to produce modular components that are applicable to aerial, ground, and sea targets as well as their ancillary systems.

Schedule

Milestones	FY98	FY99	FY00	FY01
Define TSMS Requirements	x	x	x	x
GTM Concept Definition	x	x	x	
Develop GTM Version 1(Aerial)		x	x	x
Develop GTM Version 2(Ground)			x	x
Develop GTM Version 3(Sea)				x

Progress & Completion

A program plan has been completed and approved by the Test & Evaluation Management Agency. Requirement analysis and coordination with the Generic Aerial Target Model (GATM)/ Joint Modeling and Simulation (JMASS) have been initiated.

Target Threat Validation (TTV)

The TTV project was initiated to develop and demonstrate a common target-to-threat validation process applicable to all DoD targets and to identify and track target presentation shortfalls. TTV, as depicted in Figure 16, is the process of determining the degree to which a target is an accurate representation of a threat for specific weapons systems testing or training.

Requirement

Major weapon system acquisition and procurement decisions are based on the results of testing of weapons systems under development against target vehicles. For those decisions to be informed and correct, the targets must be sufficiently representative of the threats to ensure that the testing will evaluate the weapon system within a realistic environment. Historically, the weapon system program offices were responsible for validating or ensuring that the target(s) used for T&E provided an adequate representation of the threat(s). Validation of the target was done informally if at all. The DoD Inspector General's Report 92-020 states: "DoD had not validated the extent aerial targets replicated the performance capabilities or signatures of threat missiles and aircraft during operational testing and training, and it had not quantified target limitations...recommend DoD regulations be revised to include a validation process for aerial targets and the material internal control weaknesses be reported and tracked." As a result of this report, DoD regulations now require formally validated targets during developmental and operational testing to ensure that target characteristics fall within

tolerances which adequately support specific test or training requirements.

Description

Target candidates for this project were selected based on near-term applicability of the validation data to ongoing weapon system programs. Table 1 lists the various targets that are undergoing validation under the CTEIP TTV project. The project applies to all Reliance classes of targets and spans all the Services and BMDO.

Target Class	Lead Service	Selected Target
Full-scale aerial target	Air Force	QF-4
Sub-scale aerial target	Navy	BQM-74E
Rotary wing target	Army	HOKUM-X
Missile target	Navy	EER VANDAL
Mobile ground target	Army	BMP3-S
Ballistic missile target	BMDO	MBRV-3
Surface (sea) target	Navy	MST

Table 1. CTEIP TTV Project Targets

A weapon's performance against the target/threat will be sensitive to a subset of characteristics, such as radio frequency (RF) and infrared (IR) signature and aerodynamic performance. This subset is referred to as the Target/Threat Critical Characteristics (TCCs). The values of the TCCs are gathered via existing data or measurements. A report identifies the differences between the target and threat TCC values. The report may include a

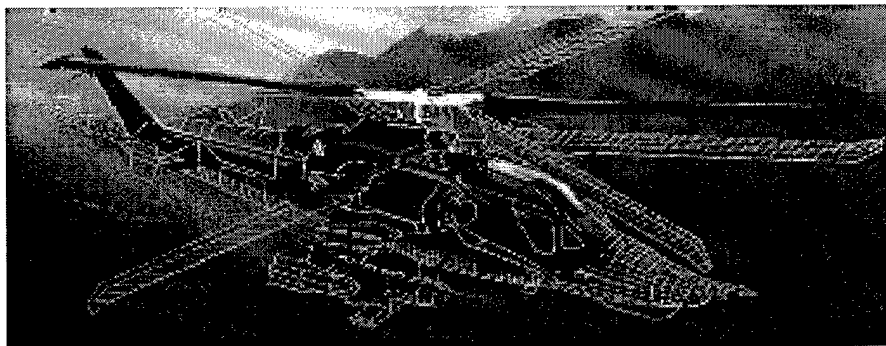

Figure 16. Target Threat Validation

test assessment detailing the impacts those differences are likely to have on specific weapons systems testing. The outcome of this process supports a decision on whether or not a particular target is sufficiently threat representative to accomplish the specific objectives of the test. This knowledge may also be used to more accurately assess how the weapon system will perform against the threat based on how it performed against the target.

Models and simulations are used extensively in the TTV and accreditation support processes. TTV uses models to compare and contrast the TCCs of the target and threat while accreditation uses simulations to evaluate the effect of target-to-threat differences on weapon system performance. Validation relies on two principal model types: signature models and performance models. Signature models represent the "appearance" of the vehicle at various electromagnetic frequencies through a variety of measurable parameters such as RF, radar cross-section, and IR radiant intensity. Performance models and simulations are used to predict both static and dynamic characteristics of the target's or threat's motion through space. Maneuverability, speed and altitude capability, and nominal trajectories are typically analyzed and compared. As with signature data, performance models can be based on either measured data or detailed computer codes that predict flight characteristics.

Benefits

Many of the validations currently underway are now producing products. These products include detailed descriptions and models of the target's performance and signature characteristics, shortfalls in the ability of the target to represent the threat, deficiencies in available threat data, and a detailed assessment of the

impact that differences between the target and threat have on testing. These products not only benefit the specific weapons system program for which the validation was performed, but also for future weapon system testing and developmental programs.

Requirements and data necessary for the process stem from the weapon system, target, and intelligence communities, while the products resulting from the process flow back into these communities, thereby benefiting all participants. This flow of information will improve threat realism in weapon system testing and provide the appropriate knowledge for improving the target presentation characteristics, which have the most significant effect on weapon system performance.

Schedule

Milestones	FY95	FY96	FY97	FY98
Planning		x	x	x
Data Collection		x	x	x
Target/Threat Comparison		x	x	x
Service Approval				x
JTOC/TSVCR Oversight		x	x	x
Complete Final Report				x
Transition Plan				x

Progress & Completion

The TTV project is in its third and final year. At this time, a DoD-wide validation process has been submitted for approval. Each of the Services and BMDO have submitted Service-unique plans which conform to the DoD standard. Each target undergoing TTV is in the final stages of gathering threat and target information in order to conduct the comparison analyses. All of the CTEIP project validation tasks are expected to be completed in mid-1998.

Translated GPS Range System (TGRS)

The TGRS project, as shown in Figure 17, provides engineering, development, and initial test sets of time-space-position information (TSPI) instrumentation based on Global Positioning System (GPS) technology to meet joint Service requirements. The TGRS consists of an airborne Digital GPS Translator (DGT) and a ground-based GPS Translator Processor (GTP). The DGT will provide an extremely compact and accurate range capability for strategic and tactical missiles and spacecraft vehicles. The GTP will miniaturize the current processing system, incorporate an all-satellites-in-view capability, reduce data latency, and track vehicles up to 75g dynamics. The design approach will provide real-time data. Production capability is being established as a design factor for the DGT and GTP to ensure that the most cost-effective material, processes, and manufacturing technology are used. The primary use for this equipment is to provide range safety and weapon system testers with accurate position data during all phases of missile launch and flight.

(BMDO) requires a light-weight, low-cost, expendable DGT that can operate in an exoatmospheric, small, hyper-velocity 75g vehicle. The GTP must provide TSPI data and high quality data necessary to perform post-flight analysis to evaluate interceptor and target performance, including flight-test lethality and miss distance with 2- to 3-foot accuracy. The GTP must perform line-of-sight (LOS) and over-the-horizon (OTH) tracking. The Air Force Space Command (AFSPC) requires the DGT to operate in space-lift launch vehicles. The GTP must provide TSPI data to satisfy range safety requirements contained in Eastern and Western Ranges Safety Regulation (EWR 127-1). The TGRS equipment and software is required to be compatible with NAVSTAR GPS satellites, tri-Service range equipment and requirements. Equipment and software must also satisfy specification requirements for the Air Force NGTCS and Space Command programs, Army BMDO programs, and the Navy Trident program.

Requirement

The need for smaller, more accurate TSPI and less expensive translators was identified in 1992. The Ballistic Missile Defense Organization

Description

The TGRS is capable of obtaining GPS TSPI for high dynamic vehicles as well as providing a communications downlink for vehicle telemetry data. The TGRS provides this information using signals from the GPS space vehicles (SVs). The system makes use of the GPS satellite L1 and L2 transmissions. The capability for both real-time output of TSPI and for optional recording of raw pre-track signals for enhanced post-flight trajectory analysis and playback is provided.

A host vehicle equipped with a DGT system accepts an input from a user-supplied, GPS-receiving, antenna system

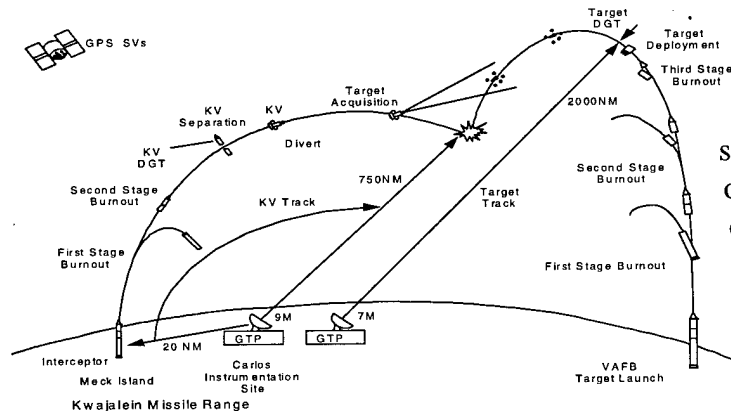

Figure 17. Translated GPS Range System

and a composite of all GPS SVs in view and filters them, down-converts them to baseband, and samples and digitizes them. The DGT is capable of recovering the GPS L1 transmissions, and when appropriately factory-configured, the GPS L2 transmissions. It is possible to configure the DGT to encrypt or not encrypt both the GPS and telemetry data. Both the digitized GPS signals and the input telemetry data is modulated onto an S-band carrier and output from the DGT subsystem for transmission to the GTP subsystem.

The GTP unit recovers the transmission from one DGT from a user-supplied, S-band-receiving antenna/preamplifier system. After demodulation, decoding, and decryption of the recovered DGT signal in the GTP, the signal components are separated into the GPS and telemetry parts. The telemetry data is output as a serial data stream for external use. This output serial data stream is a reconstruction of the input telemetry data stream into the DGT from the host vehicle. The recovered GPS signal is applied to a real-time GPS signal processor, generating a real-time state vector of the position and velocity of the host vehicle carrying the DGT.

Benefits

The TGRS provides expanded capabilities, improvements in range safety, and interoperability/commonality while maximizing the use of commercial-off-the-shelf parts, thus providing a cost-effective system. The TGRS is part of a compatible family of equipment designed to provide TSPI for low and high dynamic participants in the DoD test, training, and operation ranges. The TGRS provides the capability for real-time LOS tracking, and recording of high quality, pre-track signals for enhanced, post-flight, trajectory analysis on NMD tests involving intercept and kinetic kill impact of a target vehicle nearing the terminal

phase of a ballistic trajectory. For this application, simultaneous and independent tracking of both the target and interceptor vehicles is performed. The tracking range for the BMDO target vehicle is up to 2000 nautical miles (NM) and up to 750 NM for the BMDO kill vehicle (KV). Continuous tracking and telemetry data is performed for the interceptor from liftoff until intercept and for the target from horizon break until intercept.

The TGRS provides the capability for LOS and OTH real-time safety tracking for the Advance Medium Range Air-to-Air Missile (AMRAAM) as a subsystem to NGTCS. The TGRS provides the capability for LOS real-time range safety tracking and pre-track signal recording for Navy Trident I (using C4 analog translators) and Trident II (using D5 analog translators) missile flight tests for post-flight trajectory analysis. The GTP is capable of tracking each missile's translator RF output at S-band without pre-launch identification or firing order.

Schedule

Milestones	FY98			FY99		
Design	x	x	x			
Critical Design Review	x					
Prototype Construction		x	x			
KMR / WSMR IOC			x			
Tyndall IOC					x	

Progress & Completion

The TGRS Critical Design Review was conducted in November 1997. First deliveries of hardware are to Kwajalein Missile Range (KMR), Kwajalein Atoll, scheduled for April 1998. The Site Acceptance Test (SAT) will be conducted in August 1998, using the BMDO Ground Based Interceptor launch vehicle. Eighteen GTPs have been sold, and a Memorandum of Agreement is being prepared for coordination between the current users establishing the procedures for obtaining and sustaining the support of TGRS.

Transportable Range Augmentation and Control System

The TRACS project will develop a suite of transportable equipment and instrumentation of common range control functions. This suite, as shown in Figure 18, will augment existing test ranges during peak requirements for supporting DoD programs such as ballistic missile programs during multiple, simultaneous engagements.

Requirements

In order to conduct developmental/operational flight test and evaluation (T&E) of future DoD systems, a transportable suite of instrumentation is required to augment test support capabilities at existing DoD ranges and provide capabilities at ranges and/or remote test areas that have little or no basic instrumentation infrastructure. A system is needed to satisfy multi-Service range support requirements for Theater Missile Defense (TMD) and other testing requirements beginning in FY 2000

and continuing beyond FY 2010 at multiple locations. The tests to be supported will occur at various locations, including remote sites. Current ballistic missile test ranges--Kwajalein Missile Range (KMR), Kwajalein Atoll; Pacific Missile Range Facility (PMRF); and White Sands Missile Range (WSMR), New Mexico--do not have enough capability to test the most demanding missions scenarios. A highly transportable or mobile capability system is required for command, control and communication (C³); integrated range safety; time-space-position information (TSPD); instrumentation; data processing and analysis; and multi-source sensor reception and processing.

Description

TRACS is a self-contained, transportable system to support test mission planning, execution, real-time data collection and processing, mission

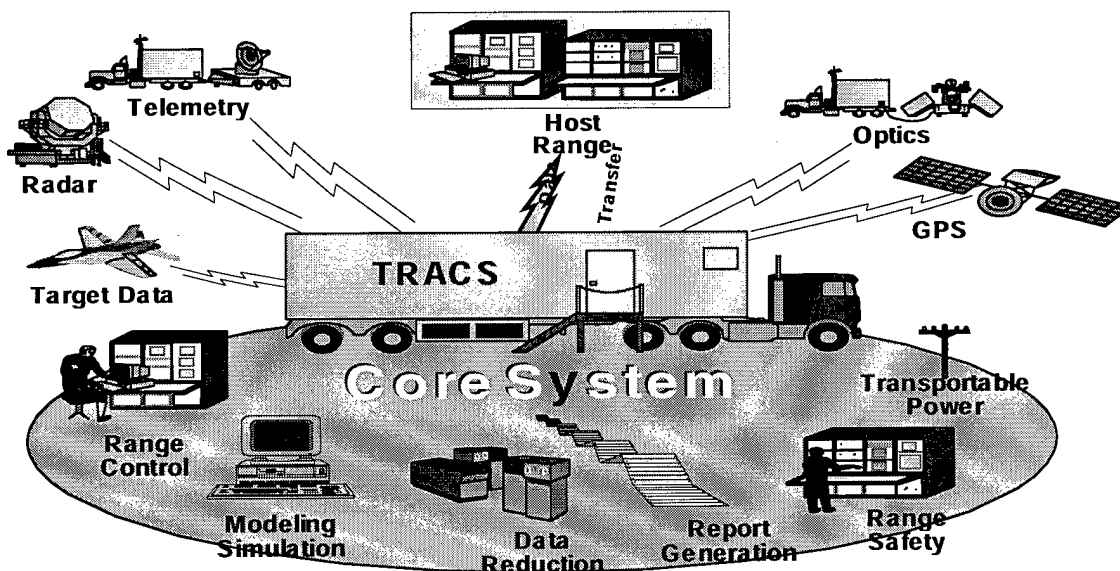

Figure 18. TRACS Suite of Equipment

control/flight safety, post-mission data analysis, and report generation. It will provide real-time TSPI, telemetry (TM) and flight termination. The equipment and instrumentation will be modular in design and van-mounted with plug-and-lay capability. It can be transported on land, sea, and air and will have imbedded interfaces to be compatible to the host range being supported. Its system interfaces will adapt to existing sensors for communication, radars, Global Positioning System (GPS), optics, TM trackers, and meteorological data. At full operating capability (FOC) it will have stand-alone capability with its own power source.

Benefits

Downsizing of the DoD infrastructure has made it impractical to modernize, maintain, or sustain T&E capabilities for infrequent maximum workload situations and complex scenarios at all potential test locations. The DoD can make more efficient use of resources with an "on-demand" capability that activates a test area only when required for live operations or augments certain parts of an existing range capability as needed to accomplish the required testing. TRACS will provide this "surge" capability during the period of maximum scenario requirements. By developing only one set of easily transportable instrumentation, millions of dollars can be saved and the DoD permanent infrastructure is not increased at several ranges. Also, reuse of recently developed software at the Major Range and Test Facility Base avoids much development cost and utilizes a proven system.

Schedule

Milestones	FY98	FY99	FY00	FY01	FY02
Design	x	x	x	x	
Critical Design Review	x				
Prototype Construction		x	x	x	x
Part I IOC			x		
Part II IOC					
FOC				x	

Progress & Completion

TRACS is in the developmental stage. It has contracted a flight termination subsystem and a TM tracker system. One of the mobile shelters has been purchased and is being fitted with the flight termination subsystem. Several test ranges have been surveyed to evaluate various software packages for displays and data processing. The General Range Intelligent Display System (GRIDS) designed at the Naval Air Warfare Center Weapons Division at Point Mugu, California, is being adopted for the display software. Both Edwards AFB, California, and WSMR are being reviewed for flight safety software. There also has been coordination with the Patriot Advanced Concepts-3, Navy Area, and THAAD Program Managers as well as PMRF, KMR, and WSMR personnel. A Memorandum of Understanding is being developed with the PMRF for TRACS support of the Navy Area testing beginning in FY01. The TRACS developmental schedule closely matches with the missile programs it will support, and an operational TRACS will be in the field by the Year 2000 to support these highly demanding programs.

Tri-Service Signature Measurement and Database System (TSMADS)

The TSMADS project will provide a capability to characterize the detailed spatial/spectral/temporal signatures of aircraft, missiles, ground vehicles, ships, undersea vehicles, and countermeasures in realistic environments. Data from these systems will be used to validate modeling and simulations, develop weapon system algorithms, and, most importantly, to increase survivability of the warfighter. TSMADS will be mobile and capable of operation at any location worldwide.

Requirement

Technology of weapon systems is advancing at an alarming rate. Seekers are becoming smarter and assets (e.g., aircraft, ships, tanks, and missiles), both blue and red, are becoming more difficult to detect. In order to support testing of these advanced concepts, new, more advanced signature measurement systems are required. Future weapon systems, threat simulators, and target development, which depend on test target and threat signature data as input to modeling and simulation (M&S) and hardware-in-the-loop simulation, cannot be properly accomplished without accurate, high-resolution

signature data. One cannot adequately predict the capabilities and limitations of a particular weapon system against a particular threat without the capability to validate the test process during test and evaluation (T&E). Powerful M&S techniques have little value in T&E unless the target signature data is available for validation. Weapon system effectiveness will be severely reduced without these advanced capabilities.

Description

TSMADS will develop four signature measurement systems: Air-to-Air Signature Measurement System (AASMS) depicted in Figure 19, Air-to-Ground Signature Measurement System (AGSMS), Ground Signature Measurement System (GSMS), and Acoustic Signature Measurement and Unaugmented Tracking System (ASMUTS). These capabilities will be developed with maximum achievable commonality and be delivered to the participating Major Range and Test Facility Base installations at initial operating capability. Once these capabilities are integrated into the MRTFB infrastructure, they will be avail-

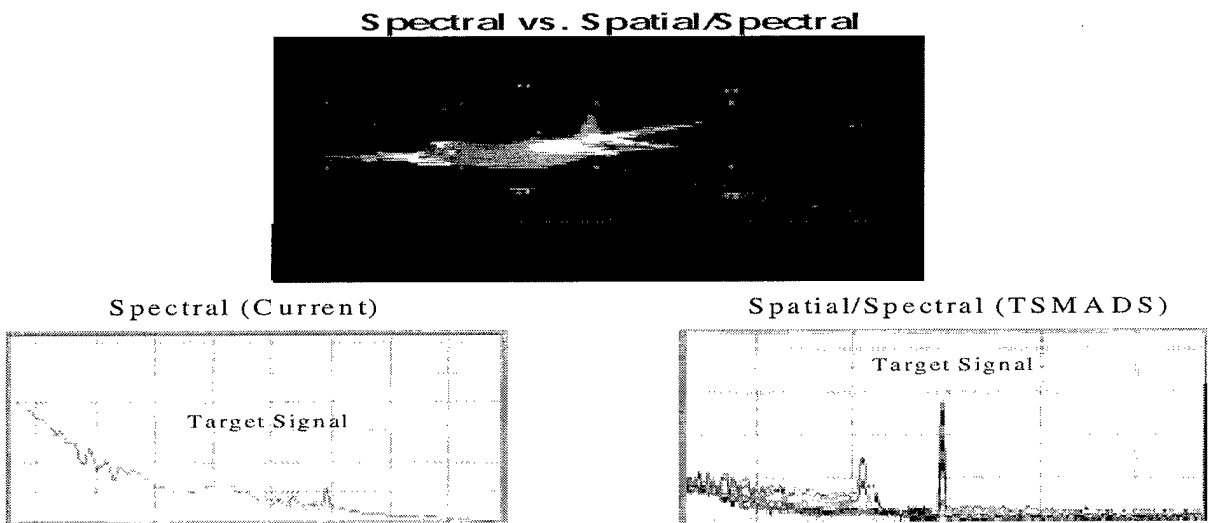

Figure 19. TSMADS Air-to-Air Signature Measurement System