

Vacuum Equipment for Ultra High Power Microwave

Experiments

Final Report on

Contract # F49620-97-1-0112

March 1<sup>st</sup> 1997 – February 28<sup>th</sup> 1999

John A. Nation.  
Cornell University  
Ithaca, NY 14853  
April 22<sup>nd</sup> 1999

19990517 016

REPORT DOCUMENTATION PAGE

AFRL-SR-BL-TR-99-

0118

Public reporting burden for this collection of information is estimated to average 1 hour per response, including the time for reviewing instructions, searching existing data sources, gathering the data, reviewing the collection of information, Send comments regarding this burden estimate or any other aspect of this collection of information, including suggestions for reducing the burden, to Washington Headquarters Service, Directorate for Information Operations and Reports, 1215 Jefferson Davis Highway, Suite 1204, Arlington, VA 22202-4302, and to the Office of Management and Budget, Paperwork Project, Washington, DC 20503.

Standard Form 298 (Rev. 2-89) (EG)  
Prescribed by ANSI Std. Z39-18  
Designed using Perform Pro, WHS/DIOR, Oct 94

1. AGENCY USE ONLY (Leave blank)		2. REPORT DATE		3. REPORT TYPE AND DATES COVERED	
				01 Mar 97 to 28 Feb 99 Final	
4. TITLE AND SUBTITLE (DURIP 97) Vacuum equipment for ultra high power microwave experiments				5. FUNDING NUMBERS 61103D 3484/US	
6. AUTHOR(S) Dr Nation					
7. PERFORMING ORGANIZATION NAME(S) AND ADDRESS(ES) Cornell University 120 Day Hall Ithaca NY 14853-2801				8. PERFORMING ORGANIZATION REPORT NUMBER	
9. SPONSORING/MONITORING AGENCY NAME(S) AND ADDRESS(ES) AFOSR/NE 801 North Randolph Street Rm 732 Arlington, VA 22203-1977				10. SPONSORING/MONITORING AGENCY REPORT NUMBER  F49620-97-1-0112	
11. SUPPLEMENTARY NOTES					
12a. DISTRIBUTION AVAILABILITY STATEMENT APPROVAL FOR PUBLIC RELEASE; DISTRIBUTION UNLIMITED				12b. DISTRIBUTION CODE	
13. ABSTRACT (Maximum 200 words)  The high vacuum insulator system we obtained did not eliminate the pulse shortening previously observed. However we did eliminate the pulse shortening, albeit with serendipity leading the way. In this case we found no pulse shortening even at 85 MW with poor vacuum. It is worth special note that the 85 MW was achieved at an rf conversion efficiency of 55%. we will now push this limit until we do get shortening and then try again.					
14. SUBJECT TERMS				15. NUMBER OF PAGES	
				16. PRICE CODE	
17. SECURITY CLASSIFICATION OF REPORT UNCLASSIFIED		18. SECURITY CLASSIFICATION OF THIS PAGE UNCLASSIFIED		19. SECURITY CLASSIFICATION OF ABSTRACT UNCLASSIFIED	
				20. LIMITATION OF ABSTRACT UL	

**Table of Contents**

1.0	Introduction	2
2.0	System Procurement and Specifications.	3
3.0	System Testing and Performance	5
4.0	Items Procured	6
5.0	Appendix	7

## 1.0 Introduction:

We report on the procurement and initial testing of a high vacuum ceramic interface to be used in our high power microwave research, which forms part of the HPM MURI East Coast Consortium Program. A total funding of \$133,341 was requested, of which \$10,000 was provided through cost sharing by Cornell University.

The use of ultra high vacuum techniques has long been a critical component of high power microwave tubes as used, for example by the high energy physics community. More recently the AFRL and MURI HPM programs have made efforts to develop ultra high power, long pulse duration, microwave sources. One feature of this work is the use of relatively poor vacuum in the sources. This has frequently been accompanied by pulse shortening of the microwave power i.e. the microwave pulse duration is less than that of the electron beam driver. It has been speculated that this may be a consequence of the base pressure in the tube. For this reason we have obtained and carried out preliminary tests on a high vacuum interface for an existing pulse power machine. The initial tests showed no differences between the poor vacuum configuration and the high vacuum configuration. Part of this may be due to the conditioning usually employed in high vacuum microwave tubes. Conditioning frequently requires millions of events to raise the power level and pulse duration without breakdowns. This is not possible in the single shot device employed in this system. More recently a new cathode configuration has been used to generate the electron beam. In this arrangement peak powers of 85 MW have been obtained with no evidence of pulse shortening in even the poor vacuum case. Severe pulse shortening had been previously observed at comparable powers. This suggests that the vacuum level may not be the critical factor in all modes of operation. Further work will be carried out during the coming year in an attempt to establish if improved microwave performance is limited by the vacuum level and, if so, can improved performance be achieved in single pulse and low repetition rate devices .

## 2.0 System Procurement and Specifications

There was significant difficulty in finding a suitable vendor for the ceramic insulator. After some searching the vendor was narrowed down to either Physics International (PI), now Maxwell Technologies, and Pulse Sciences Incorporated (PSI). Both companies are from the San Leandro area. The PSI proposal specified a conventional brazed ceramic tube, whereas the PI proposal suggested the use of a pulse power like stack of insulating rings, alternating with stainless steel grading rings. In this latter arrangement the vacuum would be maintained by a set of tie rods and helicoflex 'O' rings between the ceramic/stainless interfaces. The system can be baked up to a maximum temperature of 480° F. In view of the constraints placed on the HPM community for source conditioning and the fact that we are using an experimental facility which needs to be opened to the atmosphere frequently to modify/change the experiment we elected to accept the PI proposal, rather than the more conventional sealed system proposed by PSI. The design process entailed a study of the electrostatic field in the insulator stack under varying conditions. In particular we have used 6 oiled lucite rings in our pulse power system which generates an 800 kV pulse of 100 ns duration. The lucite has a dielectric constant of about 2.5. When the lucite is replaced by a set of identically shaped alumina rings the field distribution is changed due to the relatively high dielectric constant of the alumina ~10. This leads to higher values of the surface electric field on the rings at the cathode end of the stack. As a result we elected to add a field shaping electrode outside of the stack to relieve the stress on the first rings. In addition an additional three insulating rings were added to the insulator stack. A plot of the electrostatic field configuration with the field shaping electrode is shown in figure 1. In this plot the potential distribution obtained has also assumed the use of a coaxial copper sulfate resistor, located in the oil close to the exterior surface of the insulator stack, to help grade the field distribution. In practice this is accomplished by use of 11 copper sulfate resistors distributed around the stack periphery with a twelfth resistor, the voltage monitor. Each resistor has a 2 k $\Omega$  resistance.

The assembly consisted of 9 ceramic insulators, interspersed with metal grading rings, and mounted between two metal plates. The front plate is a ConFlat flange to mate to the high vacuum experiment and the rear was a copy of the existing flange and designed to mate to the pulse power machine. The ceramic rings are metallized with a molybdenum-Manganese matrix to permit sealing to the metallic Helico-Flex gaskets. The sealing gaskets are mounted in the metallic grading rings so that triple point field enhancements are minimized. A total of 16 ceramic and grading rings were procured leaving 7 spare which can be used for replacement of damaged rings as needed.

Insulator stack Using R,Z Coordinates Cycle = 6290

M= 3 K= 155 L= 7 27  
R = 11.783 in  
Z = 8.91844 in  
Er = 49.248 U/cm  
Ez = -3.5269 U/cm  
E = 49.374 U/cm  
U = 350.69 U

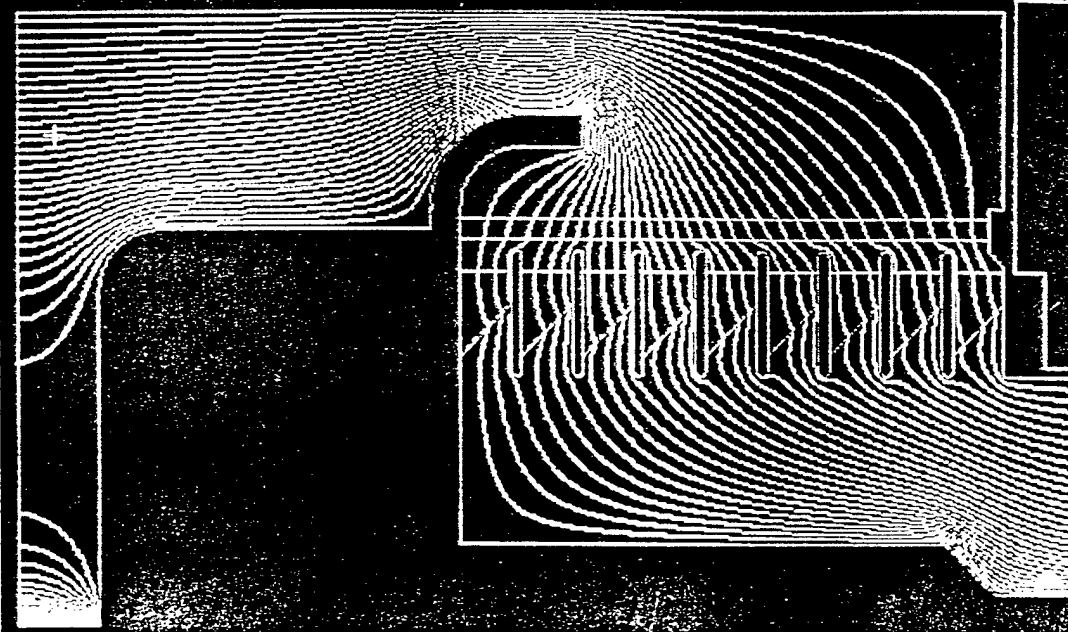

Electrostatic Field Distribution in Insulator Stack

### 3.0 System Testing and Performance

The vendor was required to demonstrate vacuum integrity to  $10^{-6}$  Torr (without baking) and to demonstrate a leak rate, after assembly of less than  $10^{-8}$  Torr-liters/s. Testing was carried out at PI who certified that the base pressure in the tube, reached  $3 \times 10^{-7}$  Torr without bake-out and that the measured leak rate was  $1 \times 10^{-9}$  torr-liters/s., well below the required specifications.

The insulator stack was delivered in the fall of 1998 and tested during the winter for about 100 shots. Following testing the system was removed from the pulser and carefully inspected. During the test period of ~100 shots there was no evidence of breakdown of the insulator when operated at the rated voltage of 800 kV. On careful inspection some discoloration of the insulator rings was found and there was evidence of localized incipient breakdown. i.e. there were light burn marks on individual insulators, but nothing propagating through the complete stack. It is felt that these marks probably arise due to the large reverse voltage found on the rings following the main 100 ns pulse. The origin of the reverse voltage is presently under investigation.

Of more interest is the observation that the pulse shortening previously observed in the HPM amplifier experiments persisted at power levels of 55 MW, even at base pressures of  $10^{-8}$  Torr. The pulse shortening phenomenon referred to above has since been eliminated at the 85 MW output power level by a change in the magnetic field geometry. At present, and in this mode of operation, the power is ~50% higher than that at which the pulse shortening was observed earlier. Once again the higher power has been observed with relatively modest vacuum and with the lucite interface.

The origins of the pulse shortening are not yet clear but are phenomenologically associated with the axial guide magnetic field profile. Satisfactory operation was achieved with the beam formed in a converging field with the cathode field about 30% of the uniform field in the microwave interaction region. There is also only a narrow range of axial guide fields for satisfactory operation.

We conclude that the previously observed pulse shortening was not due to the tube base pressure and that HPM operation is possible at the ~85 MW level with poor vacuum systems. We shall attempt to extend operation to higher power levels in the future and further test the effects of the vacuum level on the operation. Note that the HPM operation occurred at a remarkably high 55% conversion efficiency.

#### 4. Items Procured

The following items were purchased on the contract. Together they constitute the ceramic vacuum enclosure together with associated pumping systems and gauges for monitoring the vacuum. A number of conflat flanges have also been acquired for vacuum system interconnects.

<u>Item</u>	<u>Vendor</u>	<u>Price</u>
Ceramic Insulator Stack.	Maxwell-PI	\$99,205.00
Vacuum Pumps and Instrumentation	Pfeiffer Vacuum	19,072.34
Pumping Ports/components	MDC Vacuum Products	3401.76
Machining Interface to Experiment	Ide Machine Company	1235.00
Vacuum Connector Pipes	BOC Group	438.43

Total Costs from Contract \$123,352.53

Appropriated Funds \$123341.00

Cornell university cost shared with purchase of a total of \$10,000.21 for the purchase of additional vacuum equipment.

#### 5.0 Appendix

In the following pages we provide documentation showing the assembly, together with some photographs, the vacuum certification and a schematic of the assembly.

General Information  
6796 July1998

## 800 kV Ceramic High Vacuum Tube Assembly

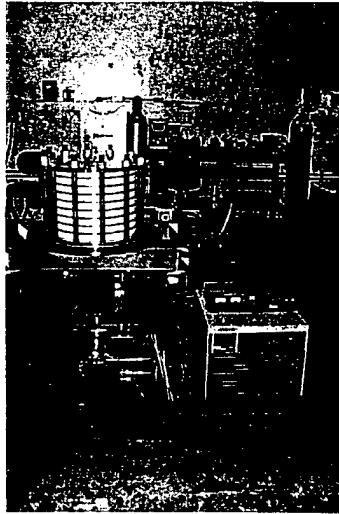

**Maxwell**  
TECHNOLOGIES  
**Physics International**

2700 Merced Street  
San Leandro, CA 94577  
(510) 357-4610

---

Dr. John A. Nation, Professor  
Laboratory of Plasma Studies and School of Electrical Engineering  
CORNELL UNIVERSITY  
325 Engineering & Theory Center  
Ithaca, New York 14853

John,

We have the insulator assembled and under vacuum with Viton O-rings. After 15.5 hours of pumping the system is down to  $5.4(10^{-7})$  torr and we expect to be below the leak rate specification of  $3(10^{-7})$  torr when we return to work next Monday.

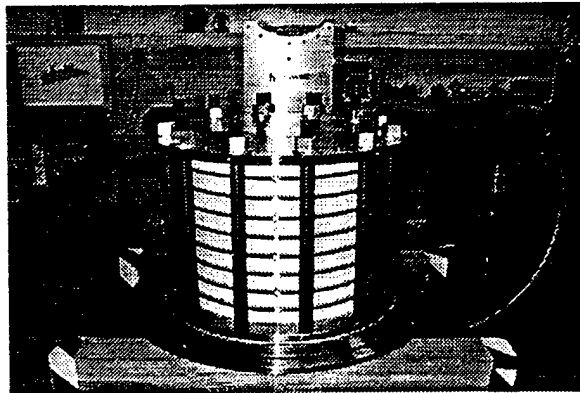

High Vacuum with 8" cryopump (cryopump attached below and not shown in this figure).

At this point we could deliver the system as is. The Viton O-rings can support bake-outs to temperatures of 300 °F. Alternately, we can install the helico-flex seals and repeat the pump-down test prior to delivery. I think this might be prudent since you should conduct a high voltage test prior to risking expending your only set of metal seals. We'll take direction from you since this choice depends on your planned use of the insulator.

Steve will communicate status to Jim Ivers next week. He'll send along an assembly procedure. We have a number of digital camera images suitable to e-mail if you are interested. We'll have some higher quality photos taken next week.

Regards,

*David Price*

David Price  
HPM Division Manager  
e-mail: [dprice@maxwell.com](mailto:dprice@maxwell.com)

# Vacuum Leak Rate Test

**Maxwell**  
TECHNOLOGIES  
Physics International

Performed by: Steven R. Pomeroy

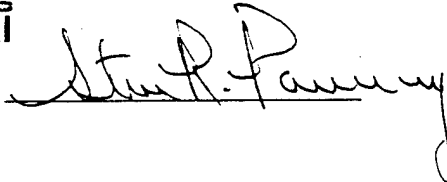

Date: 07/09/98

Re: 800 kV Ceramic Tube Assembly (with Helicoflex metal o-rings torque 40 ft-lb under vacuum)

---

## Items used

Varian Leak Detector Model#: 959 Serial#: DPAM 6006 Maxwell Property#: 000352

Varian Calibrated Leak P/N: 0981-F8473-301 Serial#: 71G-916 Maxwell Property#: 000352



## Procedure

The Varian leak detector is turned on and the calibrated leak is put on the vacuum port. The leak detector is then calibrated with this leak and then afterward let up to air. Once this is done the calibrated leak is taken off and the actual assembly (which is under high vacuum) is then connected to the Varian helium leak detector via a hose with proper connections. A check from the valve on assembly to the Varian unit itself is made. Once this region is known to not have any leaks, the valve is slowly opened and the assembly is left to stabilize for approximately five minutes. A plastic bag is placed around the assembly and is taped off to make a helium balloon. Helium (dry) gas is then filled in the bag and the leak detector is then used for sensing a leak.

## Findings

This 800 kV ceramic tube was  $6.5 \times 10^{-6}$  torr before this testing was started. The test itself measured a leak rate with the assembly  $3.6 \times 10^{-8}$  torr-liters/sec. The specification states "leak rate of less than  $3 \times 10^{-7}$  torr-liters/sec".

1.0 Photos

Gradient Rings with Viton O-rings

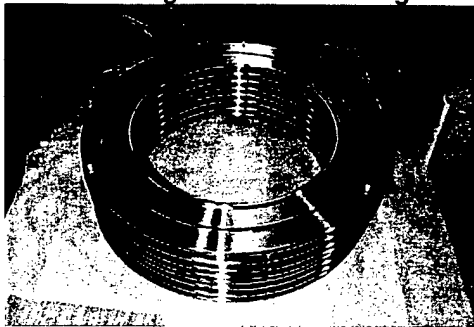

Tube Assembled without Field-shaper

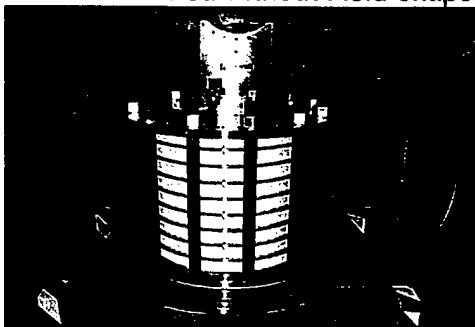

Stacked Tube with Helicoflex O-rings

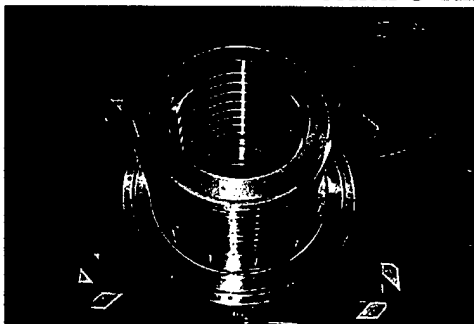

Packaged Ceramic Insulator



Ceramic Insulator on Packing Foam



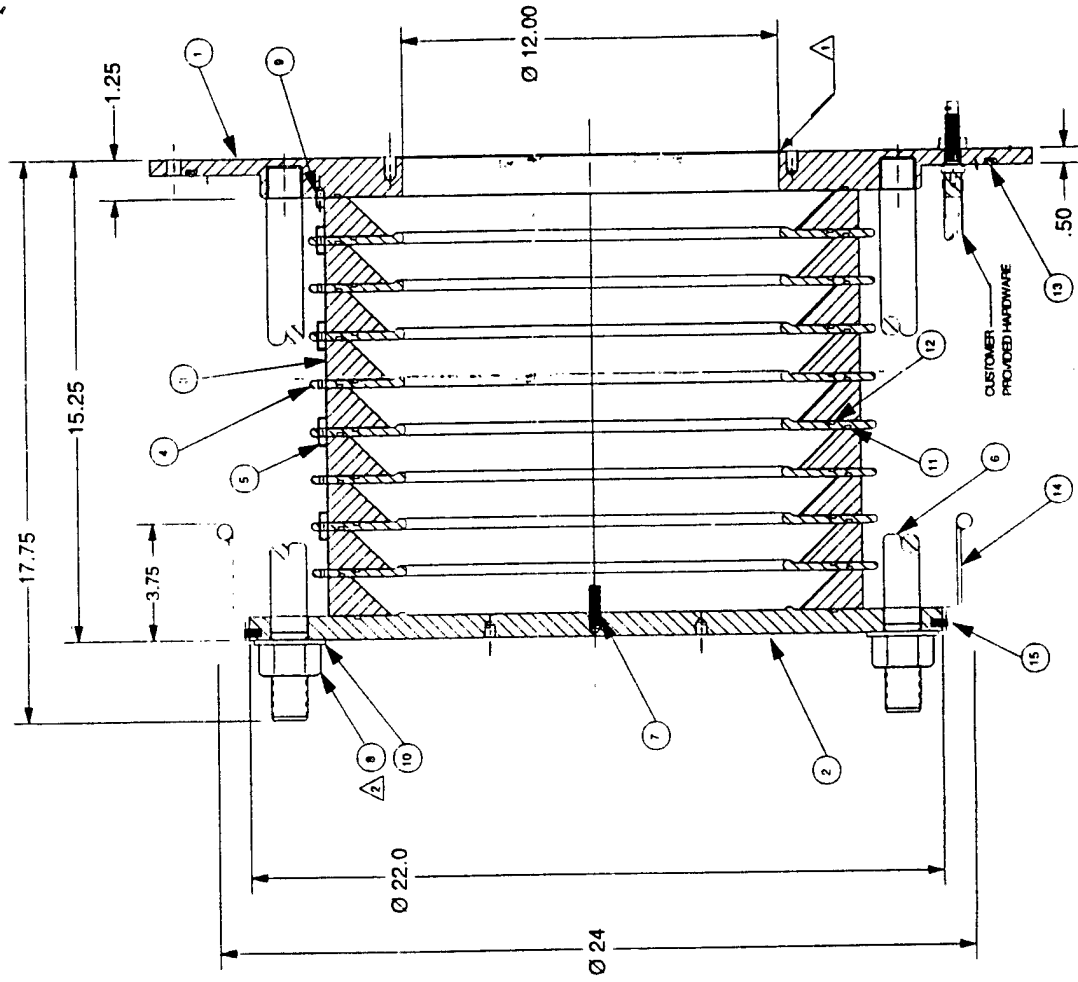
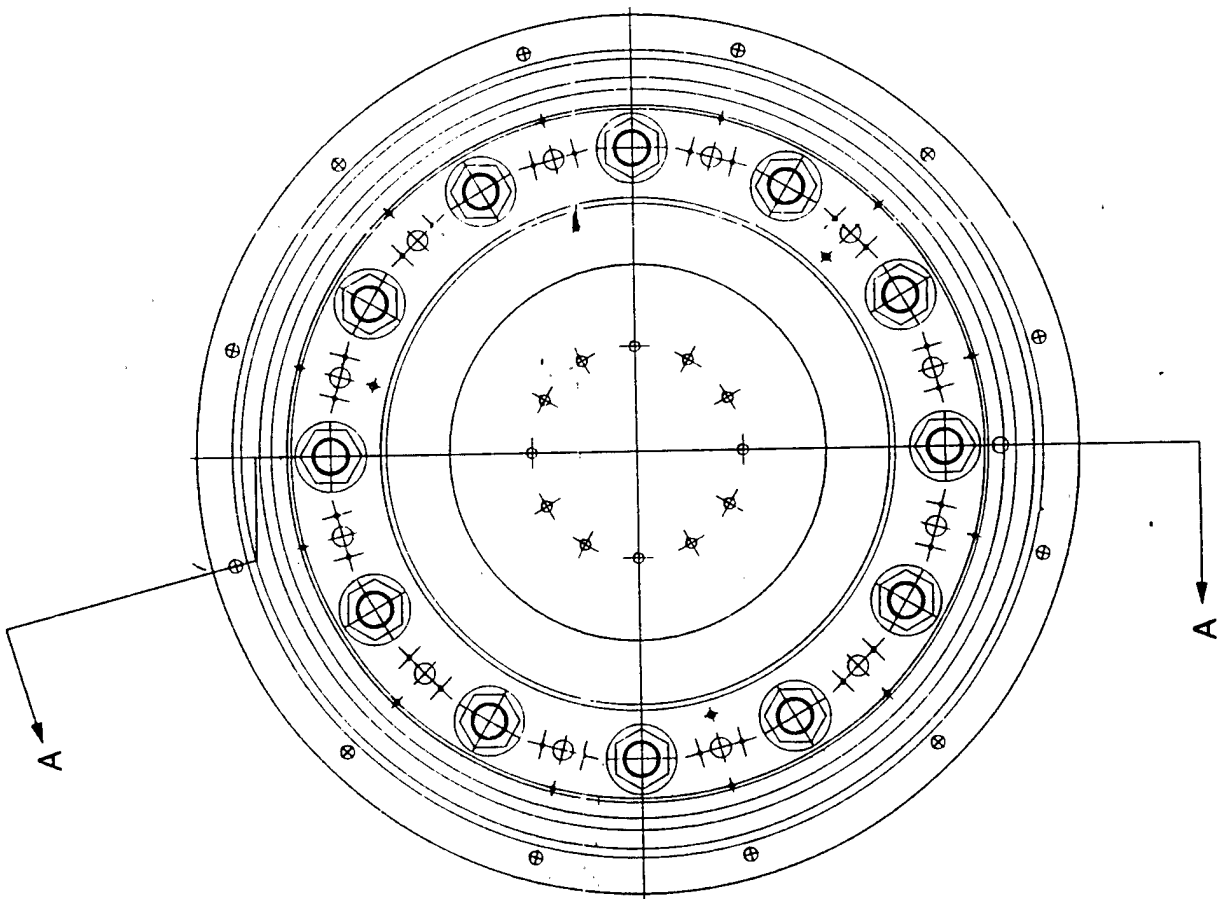

SECTION A-A